

# ***Yamato***<sup>®</sup>

## **Instruction Manual**

**3-Needle Cylinder Bed  
Interlock Stitch Machine**

---



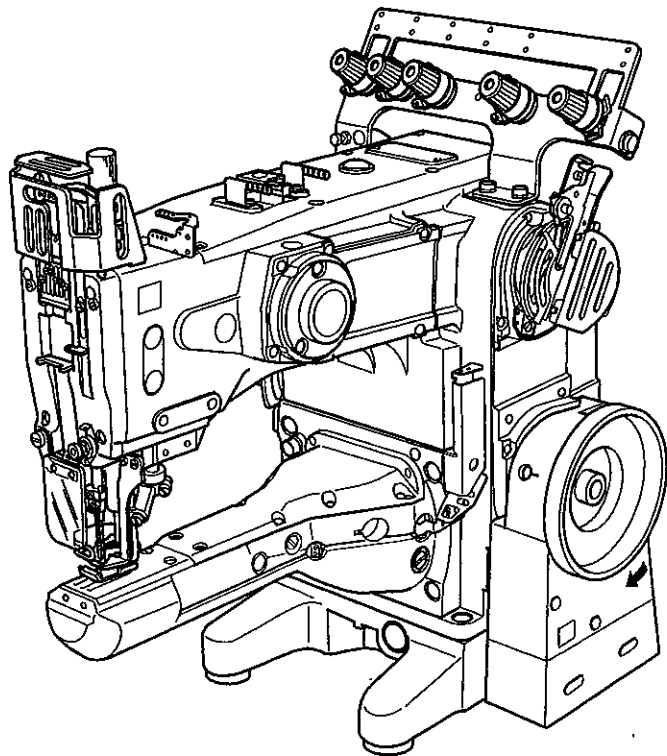





# **VT2500 Class**





Thank you for purchasing this product. This instruction manual contains information on how to handle this product and precautions in usage. Before using the product, read this instruction manual carefully and familiarize yourself with its content. Also, keep this manual in safe handy place so that others may use it as future reference.

 **YAMATO SEWING MACHINE MFG. CO., LTD.**

# Contents

<b>Safety Instructions</b>		<b>i ~ iv</b>
<b>1. Name of each part</b>		<b>1</b>
<b>2. Installation</b>		<b>2</b>
2.1	Table top type .....	2
2.1.1	Table cutting diagram .....	2
2.1.2	Installation onto table .....	3
2.2	Semi-submerged type .....	4
2.2.1	Table cutting diagram .....	4
2.2.2	Installation onto table .....	5
2.3	Motor, pulley and belt .....	6
2.4	Hanging belt .....	7
2.5	Belt cover installation .....	8
2.6	Thread tension unit installation .....	9
2.7	Eye guard and finger guard installation .....	9
2.8	Presser lifter pedal installation .....	10
 2.9	Supplementary cover installation .....	11
<b>3. Sewing speed and pulley rotating direction</b>		<b>12</b>
<b>4. Lubrication</b>		<b>13</b>
4.1	Lubricating oil .....	13
4.2	Lubricating .....	13
4.3	Changing oil .....	14
4.4	Oil filter check and replacement .....	15
<b>5. Proper operation</b>		<b>16</b>
 5.1	Detaching/reattaching cylinder front cover .....	16
5.2	Needle system .....	16
 5.3	Needle installation .....	16
 5.4	Threading .....	17
 5.5	Thread tension unit adjustment .....	18
 5.6	Presser foot pressure adjustment .....	18
 5.7	Differential feed adjustment .....	18
 5.8	Stitch length adjustment .....	19
 5.9	SP device .....	20

	5.10 Using Presser Foot Release Lever .....	20
	5.11 Fabric edge guides adjustment .....	21
	5.12 Cleaning .....	22

## 6. Machine adjustment 23

6.1 Needle thread tension adjustment .....	23
6.2 Top cover thread tension adjustment .....	24
6.3 Looper thread tension adjustment .....	24
6.4 Needle and spreader adjustment .....	25
6.4.1 Spreader adjustment .....	25
6.4.2 Top cover thread guide adjustment .....	26
6.4.3 Top cover thread eyelet adjustment .....	26
6.5 Needle and looper adjustment .....	27
6.5.1 Looper and needle distance .....	27
6.5.2 Looper angle and height .....	27
6.5.3 Looper front-rear position .....	27
6.6 Needle height .....	28
6.7 Needle guard (rear) adjustment .....	29
6.8 Needle guard (front) adjustment .....	29
6.9 Feed dog height adjustment .....	30
6.10 Presser foot position adjustment .....	30
6.11 Presser foot stopper collar adjustment .....	31
6.12 Detaching/reattaching presser foot .....	31

## 7. Troubleshooting 32

## 8. Specifications 33

### Remarks

◇ This manual has been prepared primarily for engineers, but information marked with  should be read by operators as well to ensure the machine is properly used.

◇ Illustrations in this manual bear a number under the lower left-hand corner. These numbers also appear in the body of this manual, therefore, as necessary, refer to the indicated illustration.

### Note

This product is subject to change without notice. Due to such event, the contents of this manual may not match the product in some regards. Every effort has gone into making this manual, nevertheless should you discover any mistakes or missing information, please note that it may not always be possible for Yamato to correct those errors immediately.

# Safety Instructions

## 1. To ensure safe use

Always observe the following instructions to ensure the safe use of the industrial sewing machines and devices.

### 1.1 Application and purpose

The sewing machine is designed to improve productivity in the sewing industry and must not be used for other applications and purposes. Do not use this sewing machine until it can be confirmed that safety measures for the drive units have been taken.

### 1.2 Before use

Read all instruction manuals thoroughly before starting the use of this machine and follow them.

Also, read the instruction manual for the installed drive unit.

### 1.3 Working environment

DO NOT WORK IN THE FOLLOWING ENVIRONMENTS:

- ◇ Place where atmosphere temperature and humidity give a bad influence the performance of sewing machines.
- ◇ Outdoors and place where the sewing machines are exposed to sunlight directly.
- ◇ Atmosphere containing dust, corrosive gases or flammable gases.
- ◇ Place where voltage fluctuation exceeds 710% of the rated voltage.
- ◇ Place where power capacity necessary for the used motor specifications cannot be secured.
- ◇ Place where strong electric or magnetic fields are generated such as near large-output high frequency transmitters or high frequency welding machines.

## 1.4 Unpacking and transportation

- (1) Unpack from the top.
- (2) Never hold the parts near the needle or threading parts when removing the sewing machine head from the buffer of box.
- (3) When carrying the sewing machine head, have an assistant.
- (4) Pay attention not to get excessive impact or shock when moving the sewing machine head with a pushcart.

## 2. Installation and preparation

Always observe the following instructions to ensure the safe use of the industrial sewing machines and devices.

### 2.1 Instruction and training

Operators and workers, who supervise, repair or maintain the machine head and machine unit, are required to have the adequate knowledge and operation skills to do the job safely. In order to establish such necessary conditions, it needs for the employer to plan and enforce the safety education and training to those workers.

### 2.2 Sewing table and motor

- (1) Prepare a machine table that has enough strength to withstand the weight of the sewing head and any reaction while operating.
- (2) Maintain a comfortable working environment with considering the lighting and the arrangement of sewing machine so that the operators can work smoothly.
- (3) When installing the control box and the related parts on the sewing machine, take care about the posture of the worker.
- (4) Install the drive unit correctly according to the instruction manual.

### **2.3 Wiring**

- (1) Never connect the plug for power supply until assembly is finished.
- (2) Fix the connectors securely to the sewing machine head, motor, and electric apparatus.
- (3) Do not apply excessive force to the connection cords.
- (4) Connect the cords away from the driving parts.
- (5) Place the ground wire securely to the designated position on the machine head.

### **2.4 Before operation**

- (1) Take care not to attach lubricant, silicone oil, and grease on the eyes or skin. Keep them away from children.
- (2) Be sure to fill or drop lubrication oil before operating the sewing machine. Use the Yamato SF oil as specified.
- (3) Never put your hand under the needle or near the moving parts of the machine when turning on power supply switch.
- (4) When operating a new sewing machine, make sure the rotating direction of pulley agrees with the rotating-direction mark.

### **2.5 During operation**

- (1) Be sure to operate the sewing machine with the safeguards such as belt cover, finger guard, and eye guard.
- (2) Never place the finger, hair or objects under the needle or close to the moving parts while operating the sewing machine.
- (3) Be sure to turn off the power supply switch when threading or replacing the needles.
- (4) Never place your hands close to the knives when operating the sewing machine with the trimming devices.
- (5) Be sure to turn off the power supply switch when terminating the sewing work or leaving the sewing machine.

- (6) If the sewing machine malfunctions, abnormal sound or smell something unusual while operating, be sure to turn off the power supply switch.

### **2.6 Removal**

- (1) Turn off the power supply switch if removed or replaced any parts or during adjustment of sewing machine.
- (2) Do not pull the cord when removing the plug. Be sure to hold the plug itself.
- (3) A high voltage is applied inside the control box. Turn off the power supply switch and wait more than 5 minutes before opening the cover.

## **3. Maintenance, inspection, and repair**

- (1) Follow the instruction manuals for maintenance, inspection, and repair.
- (2) Entrust the maintenance, inspection, and repair to specially trained personnel.
- (3) Be sure to turn off the power supply switch and make sure that the sewing machine and motor completely stop before the maintenance, inspection, and repair. (If using a clutch motor, take care that the motor keeps turning for a while even after turning off the power supply switch.)
- (4) Do not modify the sewing machine by the customer's judgment.
- (5) Be sure to use original replacement parts for repairs or maintenance.

## 4. Caution signs and alert pictorial markings

This instruction manual contains the following caution signs and alert pictorial markings to prevent you from injuring yourself or the sewing machine from being damaged.

Please follow the instructions.

### 4.1 Meanings of caution signs

#### ⚠ WARNING

indicates potentially hazardous situations which, if not heeded, could result in death or serious injury to you and others.

#### ⚠ CAUTION

indicates hazardous situations which, if not heeded, may result in minor or moderate injury to you and others, or may result in machine damage.

### 4.2 Alert pictorial markings



This mark indicates the warning which, if not heeded, could result in death or serious injury.



This mark indicates the caution for high temperature.



This mark indicates the warning which, if not heeded, could result in death or Serious injury. And also this mark is used to emphasize the important information.



High-voltage applies in the control box. This label indicates that electric shock may be caused.



This mark indicates the caution which, if not grounded, the machine or device could malfunction and could result in personal injury.

## 5. Warning labels on sewing machines

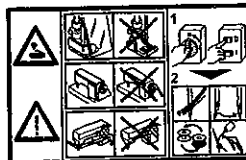

This label indicates that removal of the safeguards and works except for sewing performance while the power supply switch is on are prohibited. (For details, see the next page.)

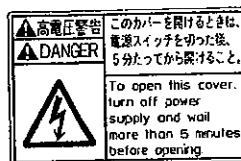

High-voltage applies in the control box. This label indicates that electric shock may be caused.



This label is affixed on the safeguards. Considering the operation, it is not affixed on the finger guard and eye guard. Be sure to operate with the finger guard and eye guard in position.



Stepping motor and solenoid may overheat if used continuously. To prevent a burn, take care not to touch.



If not connected earth line, static electricity may be generated and inflict injury on person. In addition, the malfunction of electric system may cause injury to person.



Check the rotating direction of machine pulley agrees with 'ROTATING-DIRECTION SYMBOL'.

# ⚠ Safety Instructions ⚠

## 6. Location of Safety Labels

Safety labels are placed adjacent to potential hazards.

Keep these labels clean and easily readable at all times; should a label become damaged or lost, a replacement should be ordered.

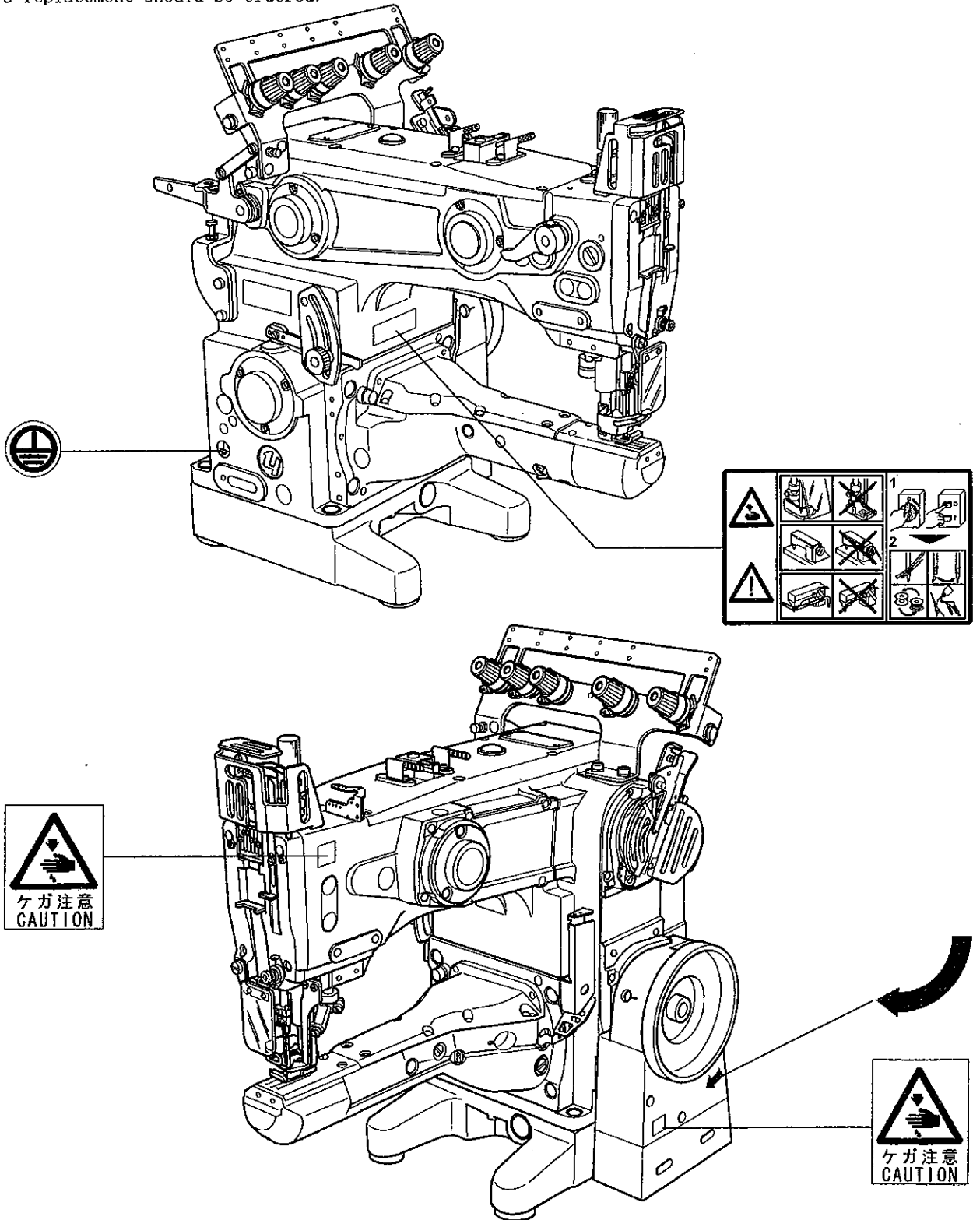

# 1. Name of each part

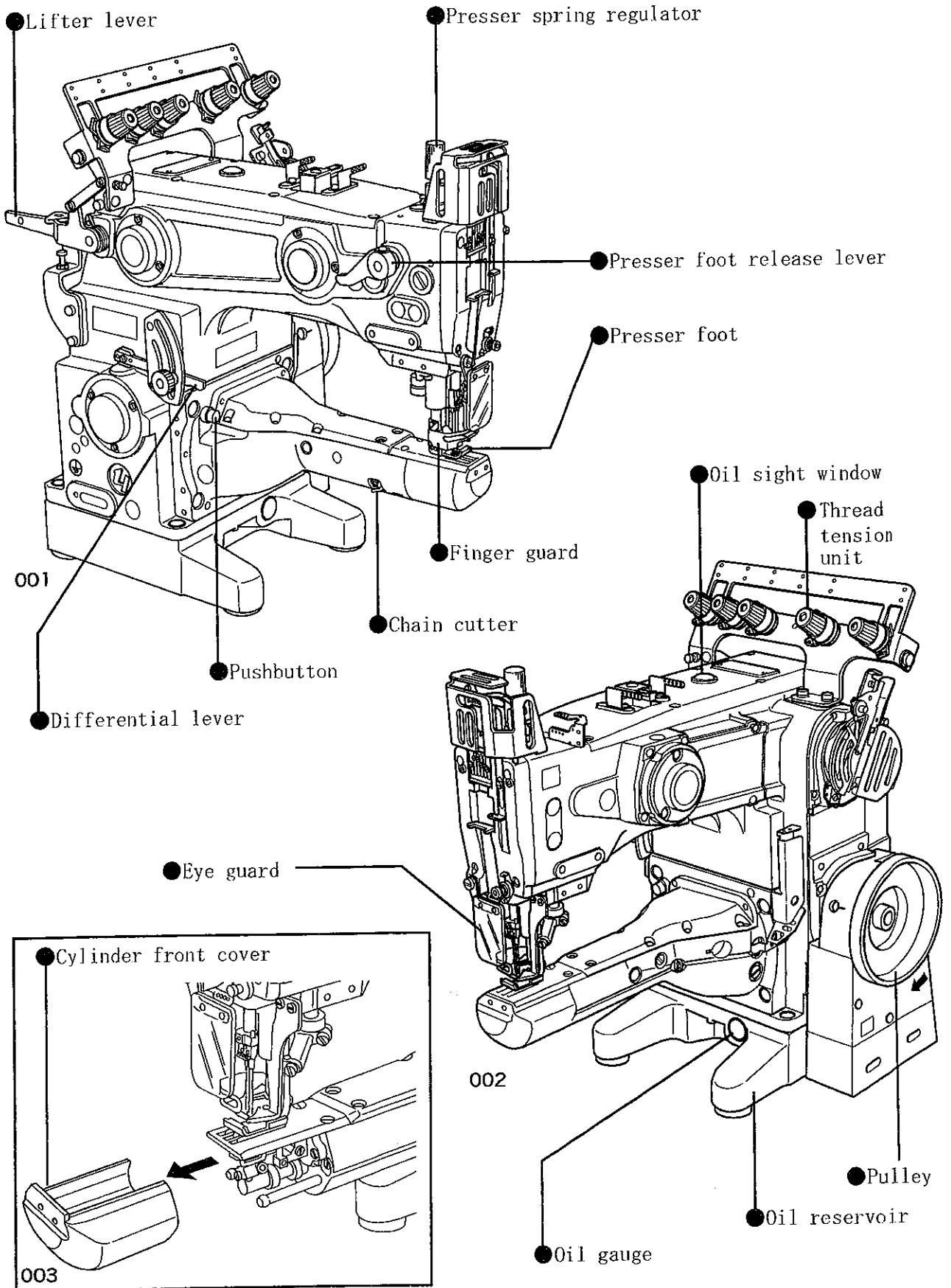



# 2. Installation

## 2.1 Table top type

### 2.1.1 Table cutting diagram

Presser lifter shaft support installation location

Pedal position	E	F
Right	260	270
Left	200	410

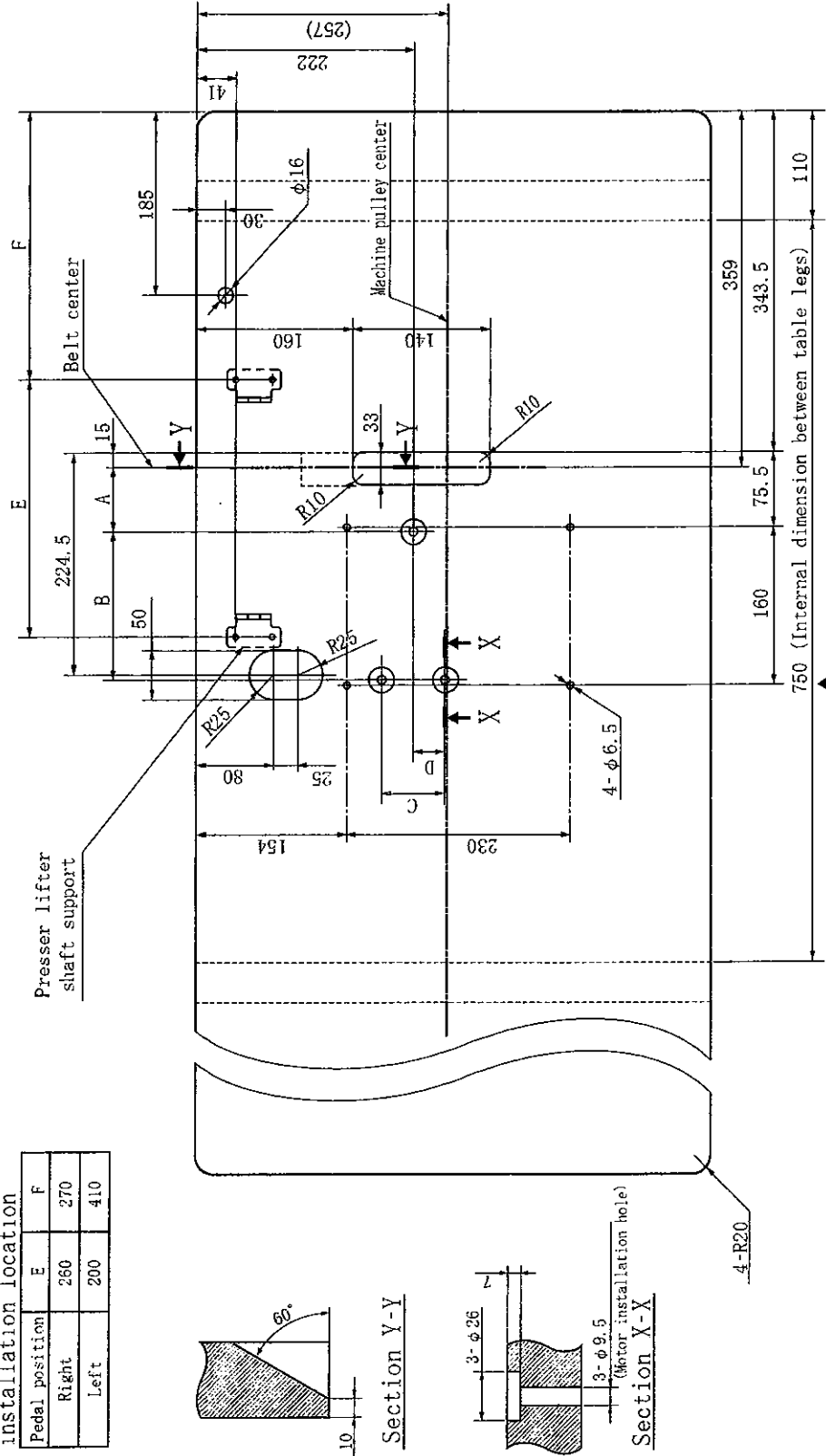

Table external dimensions: 1200 × 595 × 40 (mm)

Operator

\* For dimensions A, B, C and D, see the Instruction Manual of the motor.

## 2. Installation

### 2.1.2 Installation onto table

#### CAUTION

The sewing machine weighs 42 kg or more. Work in twos or more when unpacking, carrying and installing the machine.

Install the sewing machine correctly as shown in Fig. 004, 005 and 006.

- (1) Attach the bolts and nuts to the machine table.
- (2) Cover the bolts with the rubber cushions.
- (3) Set the sewing machine over the rubber cushions.

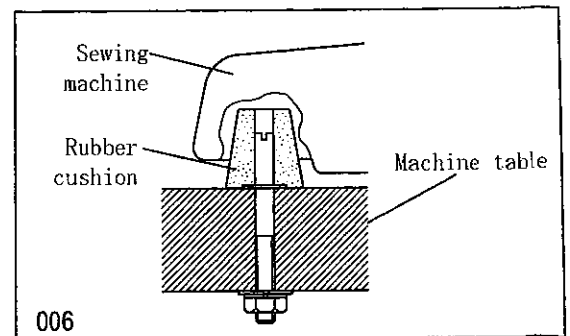
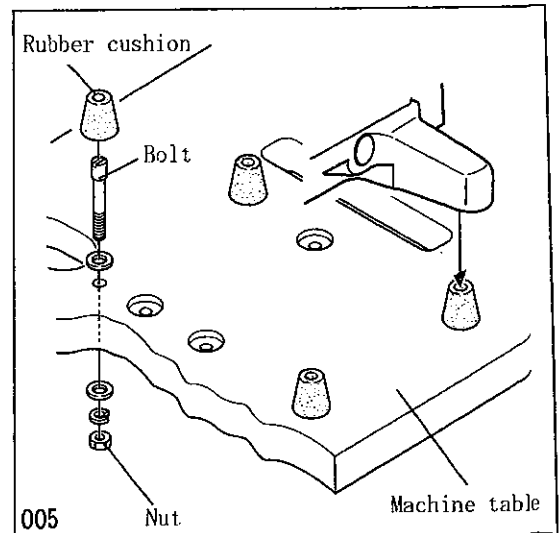

**2.2 Semi-submerged type**

**2.2.1 Table cutting diagram**

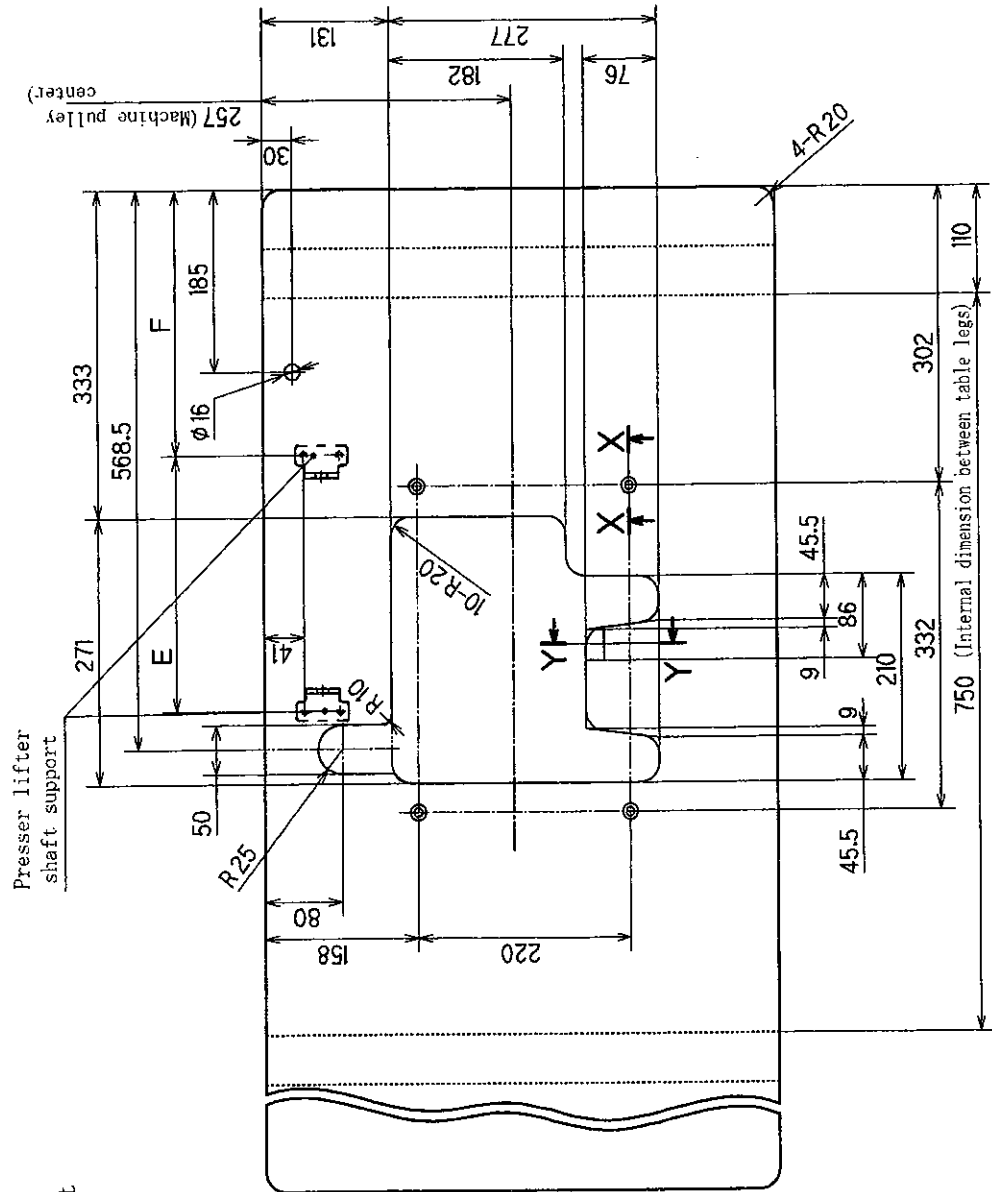

Presser lifter shaft support installation location

Pedal position	E	F
Right	260	270
Left	200	410

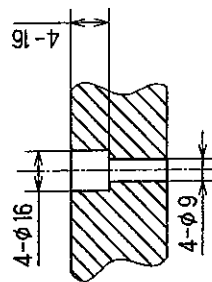

Section X-X (1/2) (4 places)

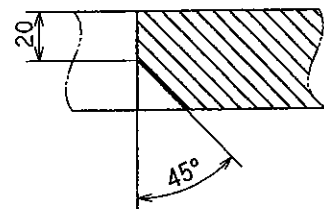

Section Y-Y (1/2)

Table external dimensions: 1200 × 595 × 40 (mm)



Operator

## 2. Installation

### Supporting board

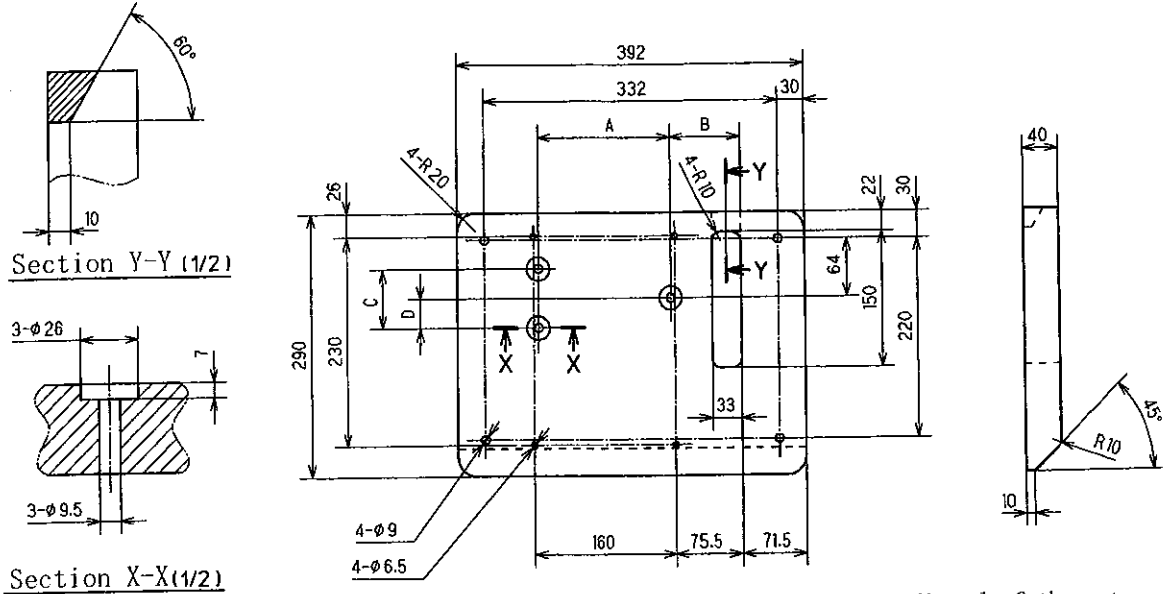

008

\* For dimensions A, B, C and D, see the Instruction Manual of the motor.

### 2.2.2 Installation onto table

#### ⚠ CAUTION

The sewing machine weighs 42 kg or more. Work in twos or more when unpacking, carrying and installing the machine.

Properly install the sewing machine referring to the figures 007, 008, 009 and 010.

- (1) Attach the bolt ② (4 in total) to the supporting board ①.
- (2) Cover the bolt ② with the rubber cushion ③.
- (3) Fix the supporting board ① to the machine table ② while inserting the two supporting board spacers ⑤ between the board and the table.

#### Notes

- If the thickness of the table exceeds the standard (40 mm), use the rubber cushion spacer ④ or adjust the number of the supporting board spacers ⑤.
- The top surface of the stitch plate is typically approx. 100 mm high from the table.

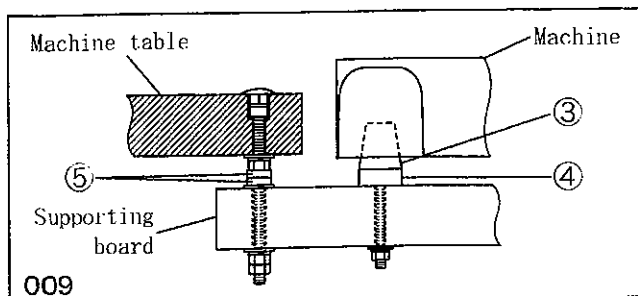

009

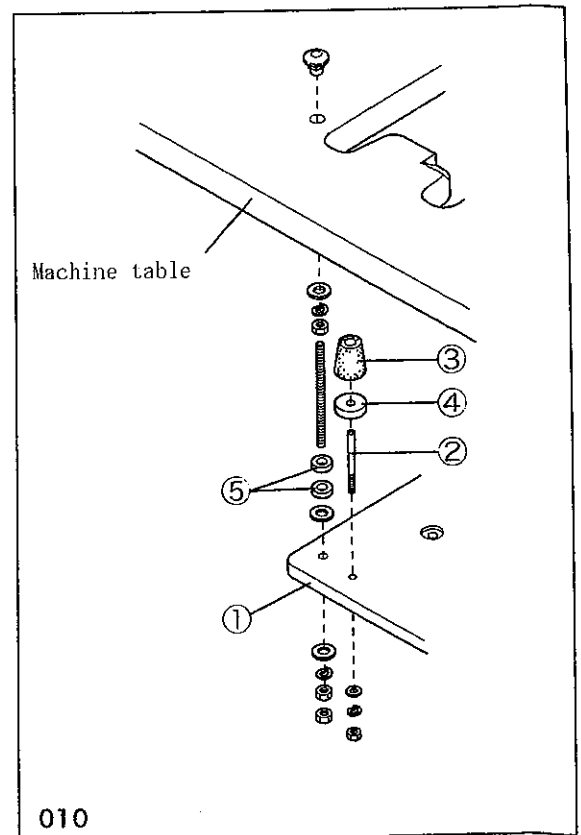

010

## 2.3 Motor, pulley and belt

### Clutch motor

- ◇ See the instruction manual of the motor you are using.
- ◇ The clutch motor should be installed in a position where the center of the motor pulley ② and the center of the machine pulley ① align with one another when the pedal is depressed and the motor pulley ② moves to the left.
- ◇ Commercially available pulleys have outer diameters incremented every 5 mm, therefore pulleys are specified by commercial sizes.

### ⚠ CAUTION

Use of an inappropriate motor pulley may cause the sewing machine to exceed the maximum speed whereby resulting in breakdown.

### Servomotor

See the instruction manual of the motor you are using.

Calculate motor pulley outer diameter from the below formula. Or select the best size of motor pulley from Table 2.

$$\text{Motor pulley O.D.} = \frac{\text{Sewing speed}}{\text{Servomotor speed}} \times 66.5 + 5\text{mm}$$

- ◇ Commercially available pulleys have outer diameters with every 5 mm increment, therefore select a pulley of an outer diameter that is near to the calculated outer diameter.

### Belt

Use an M-type V-belt.  
For sizes, see Table 1.

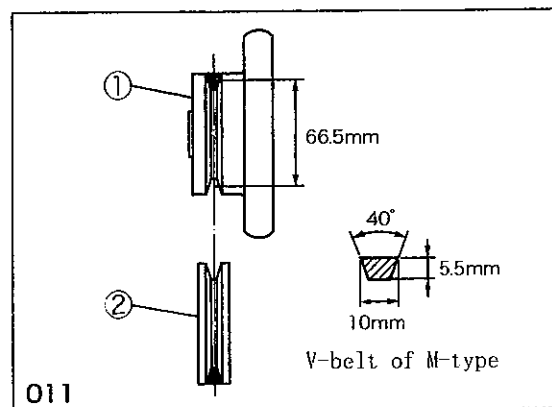

Table 1

Motor pulley O.D. (mm)	Sewing speed (rpm)		Belt size
	50Hz	60Hz	
75		3600	M36
80		3850	M36
85	3400	4100	M36
90	3600	4350	M37
95	3800		M37
100	4000		M37
105	4200		M38
110	4400		M38

- ◇ Numerical figures are given for a 3-phase, 2-pole, 550 W (3/4 HP) clutch motor.

Table 2

Sewing speed (rpm)	Motor pulley O.D.	
	Servomotor speed (rpm)	
	3000	3600
3500	83	70
3800	89	75
4000	94	79
4300	100	84
4500	105	88

- ◇ Numerical figures are examples for servomotors of 3000 and 3600 rpm.

## 2. Installation

### 2.4 Hanging belt

#### CAUTION

Turn off the power switch of the motor and check the motor has stopped before hanging or replacing the belt. If not, hands or clothing may become entangled whereby resulting in injury.

- (1) Hang the belt ① around the machine pulley ②.
- (2) While turning the machine pulley ②, hang the other end of belt ① around the motor pulley ③.
- (3) Stretch the belt so that the belt has a 10 to 20 mm slack when a force of about 10 N (1.02 kgf) is applied to the center of the belt.
- (4) Once the belt is sufficiently taut, securely lock the motor pulley.

\*How the motor is locked down differs depending on motor, therefore see the instruction manual of the motor.

#### SUPPLEMENT

Semi-submerged installation of the machine requires the supplementary belt cover to be installed before the machine is mounted on the table and the belt is hanged in place. See page 8.

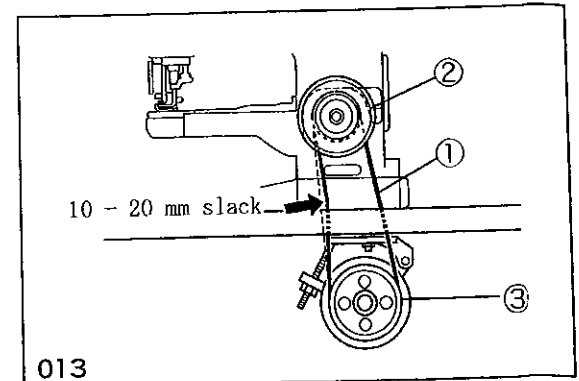
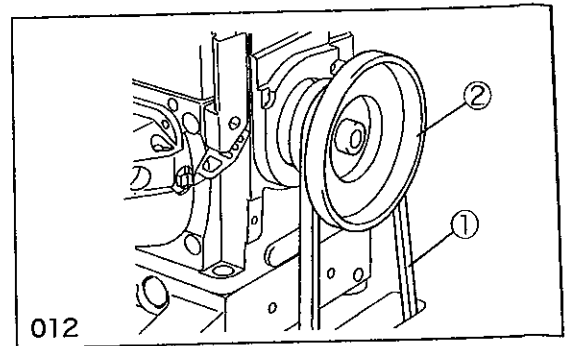

## 2.5 Belt cover installation

**⚠ CAUTION**

- Turn off the power switch of the motor and check the motor has stopped before installing the belt cover. Working with the power on can result in injury.
- Install the belt cover without fail.  
If the belt cover is not installed, hands, clothing or the stitched fabric may become entangled in the belt resulting in injury or damage.

- (1) Insert the screws ② halfway into the oil reservoir ①.
- (2) Fit the holes on the supplementary belt cover ③ over the heads of the screws ②, slide the cover to the rear and tighten the screws ②.

- (3) Attach the belt cover(lower) ④ to the sewing machine with the screws ⑤.

- (4) Fit the belt cover(upper) ⑥ onto the belt cover(lower) ④ and lock in place with the screws ⑦.

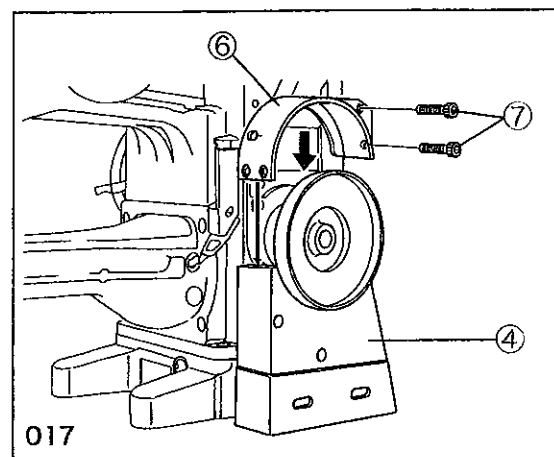
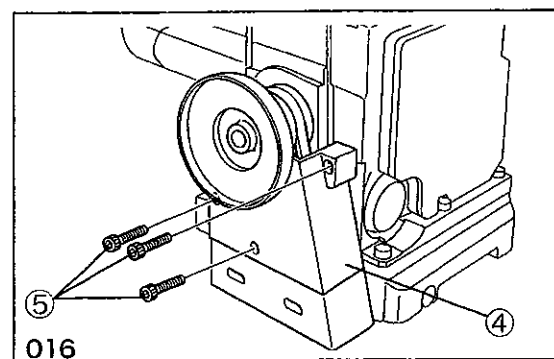
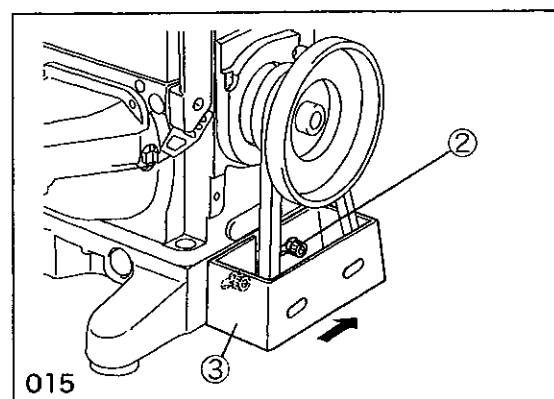
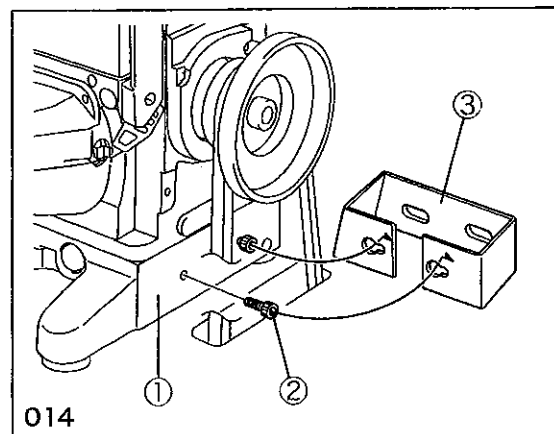

## 2. Installation

### 2.6 Thread tension unit installation

- (1) Attach the thread tension unit to the sewing machine with the screws ② ③ and the washers ④ (2 on each left and right.)

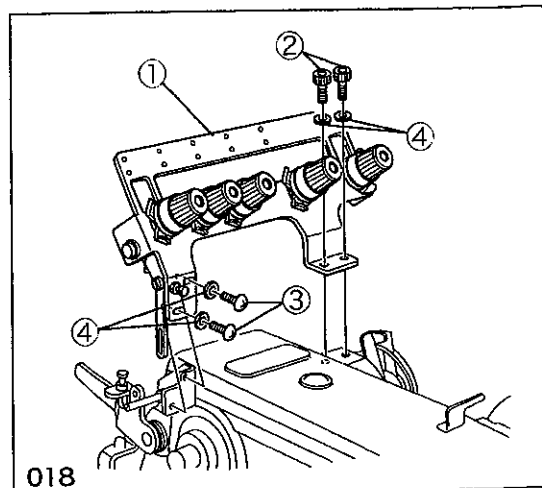

- (2) Attach the tension release lever connector ⑤ to the lifter lever ⑥ with the screw ⑦.
- (3) Press the lifter lever ⑥ downward to check it moves smoothly.

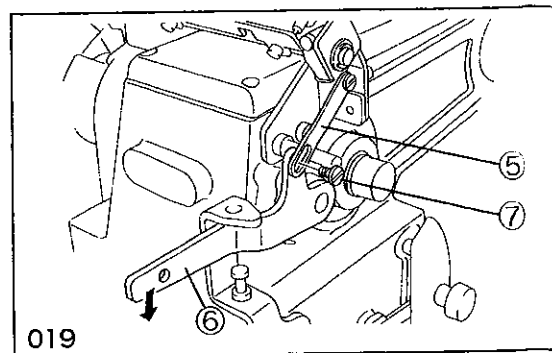

### 2.7 Eye guard and finger guard installation

#### CAUTION

Use the sewing machine with the eye guard ⑧ and the finger guard ⑨ attached. Also, lower the eye guard ⑧ to the set position when working.

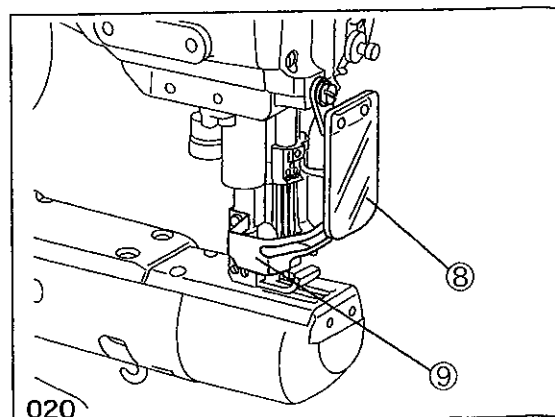



## 2.8 Presser lifter pedal installation

Attach the presser lifter shaft(lower) ③ on the underside of the table and then connect the presser lifter pedal and lifter lever ⑦ to the presser lifter shaft(lower) ③ by chain ⑧.

- (1) Attach the presser lifter shaft support ① on the underside of the table with the screws ②.
- (2) Pass the presser lifter shaft(lower) ③ through the collar ④, return spring ⑤, lifter shaft lever ⑥ and presser lifter shaft support ① as shown in the figure.
- (3) Check that the presser lifter shaft(lower) ③ turns smoothly.

- (4) Move the collar ④ to the left and right so that the arm of the presser lifter shaft(lower) ③ is directly beneath the lifter lever ⑦.
- (5) Lock down the arm of the presser lifter shaft(lower) ③ so that it is parallel to the lifter shaft lever ⑥.
- (6) Connect the arm of the presser lifter shaft(lower) ③ and the lifter lever ⑦, the lifter shaft lever ⑥ and the presser lifter pedal by chains ⑧.

When attaching pedal to the right side of table

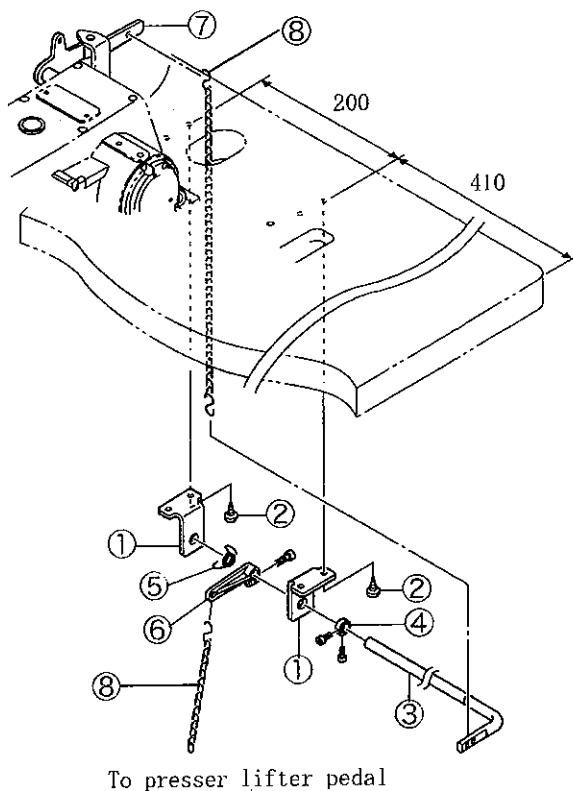

021

When attaching pedal to the left side of table

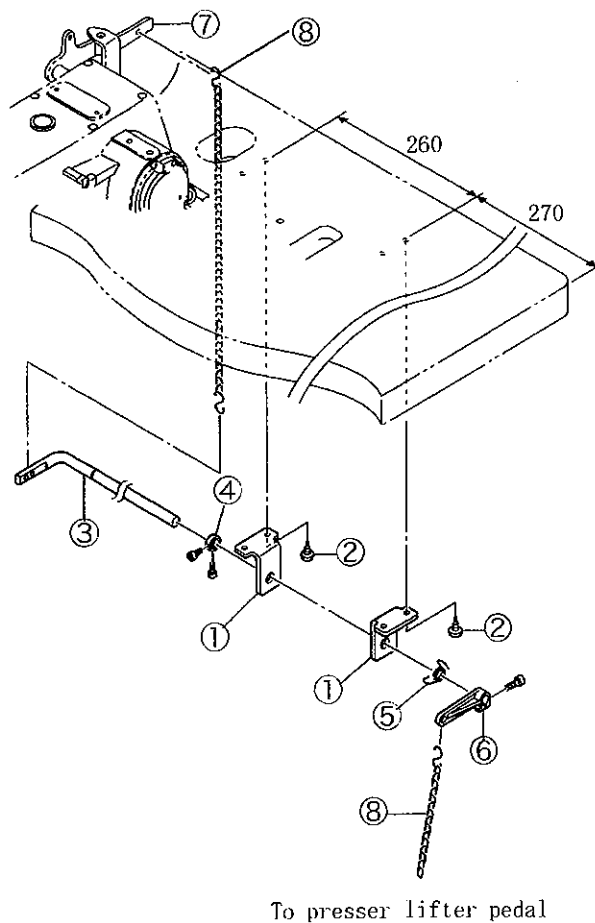

022

## 2. Installation

### 2.9 Supplementary cover installation



Attach the supplementary cover ① to the cylinder front cover ② with the screws ③.

\* The fabric edge guides ④ ⑤ can be attached to the supplementary cover ① with the screws ⑥ ⑦ and the washers ⑧.

#### CAUTION

Turn off the power switch of the motor and check the motor has stopped before installing the supplementary cover. Working with the power on can result in injury.

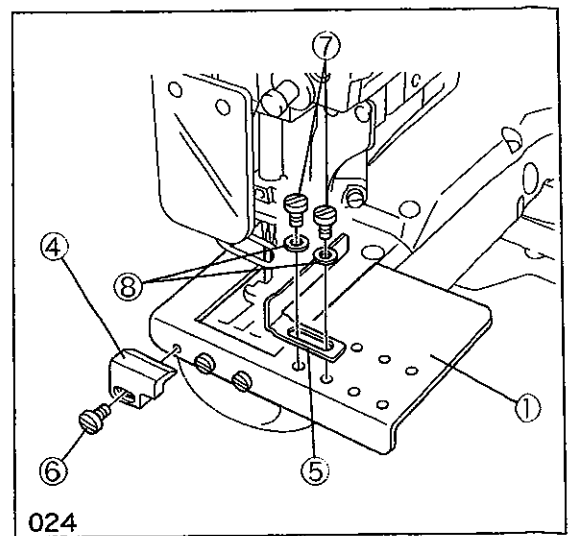
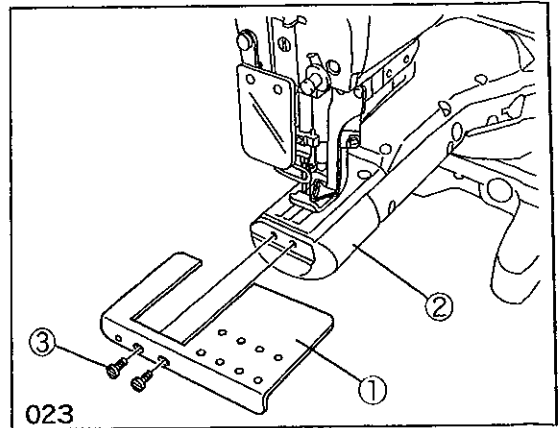

### 3. Sewing speed and pulley rotating direction

- ◇ The maximum speed of this sewing machine is 4500 rpm (intermittent operation). When using it for the first time, run the machine at 15% to 20% lower speed of its maximum sewing speed during the first 200 hours (approx. 1 month) so that it will offer a long service life in good condition.
- ◇ Both the motor pulley ② and the machine pulley ① rotate in the clockwise direction.

#### **⚠ CAUTION**

If the pulleys rotate in reverse direction, oil can not be properly supplied to parts resulting in sewing machine breakdown.

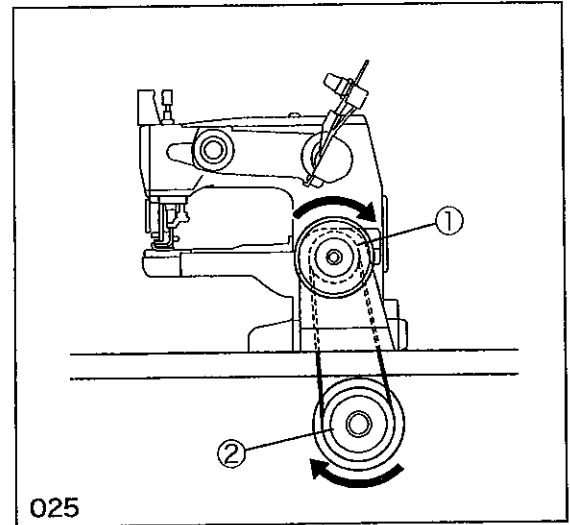

# 4. Lubrication

## ⚠ CAUTION

Turn off the power switch of the motor and check the motor has stopped before performing work. Working with the power on can result in injury.

### 4.1 Lubricating oil

## ⚠ CAUTION

Do not use oil additives as they can deteriorate the oil resulting in sewing machine breakdown.

- ◇ Lubricating oil: YAMATO SF OIL No.28
- ◇ Capacity of oil reservoir: 600 mL

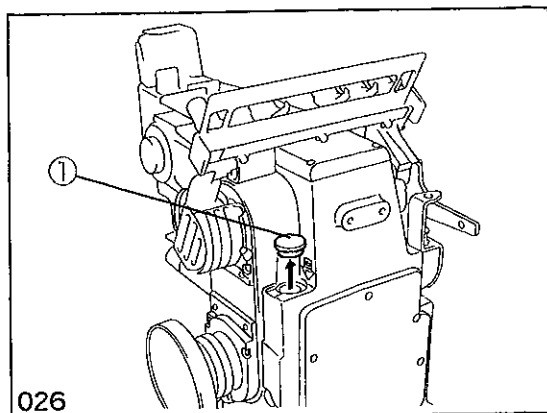

### 4.2 Lubricating

#### When using a sewing machine for the first time

A sewing machine is shipped with the oil drained. Before using a sewing machine for the first time, charge with oil. To add oil, remove the rubber seal plug ① labeled "OIL" and add oil up to the top line on the oil gauge ②.

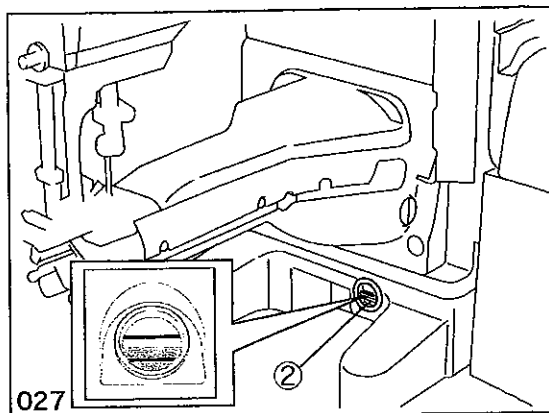

#### Checking point

After starting the sewing machine, check oil is coming from the nozzle when looking from the oil sight window ③. If oil is not coming out, check and replace the oil filter (see page 15).

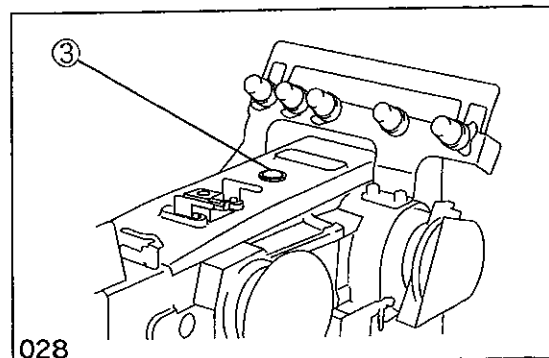

## ⚠ CAUTION

If very little oil is sprayed out from the nozzle despite a sufficient charge of oil or if there are many bubbles in the oil, check and replace the oil filter.

## 4.3 Changing oil

### Oil changing interval

With a new sewing machine, change the lubricating oil after about 200 hours (approx. 1 month) of use. After that, change the oil once or twice a year.

### How to change

- (1) Remove the belt cover. (See page 8.)
- (2) Remove the V-belt from the sewing machine. (See page 7.)
- (3) Remove the sewing machine from the machine table.
- (4) Set a container for collecting the oil underneath the drain hole.
- (5) Remove the drain hole screw ①.  
The oil is drained out.

### CAUTION

Be careful not to get oil on the V-belt or machine pulley.

- (6) Screw back the drain hole screw ①.
- (7) Remove the seal plug ② labeled "OIL".
- (8) Change with new oil. (See page 13.)
- (9) Set the sewing machine on the machine table.
- (10) Hang the V-belt around the motor pulley and reinstall the belt cover. (See page 7 and 8.)

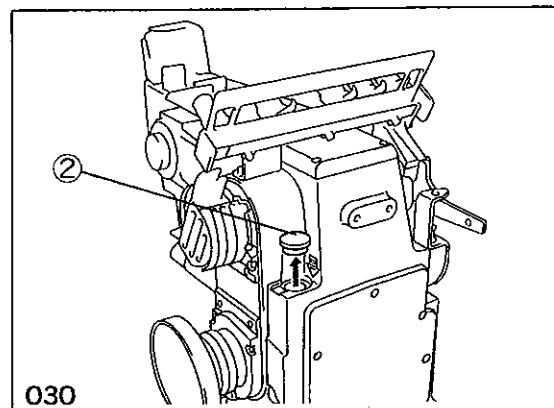
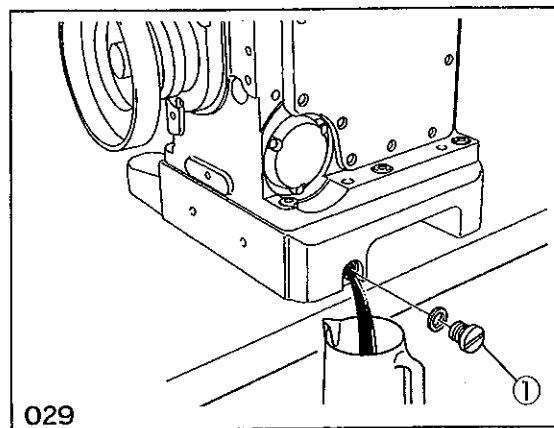

## 4. Lubrication

### 4.4 Oil filter check and replacement

- ◇ Oil is not properly supplied if the oil filter ① becomes clogged with dirt. Check the filter for clogging and breakage every 6 months.
- ◇ If very little oil is sprayed out from the nozzle despite a sufficient charge of oil or if there are many bubbles in the oil, check and replace the oil filter.

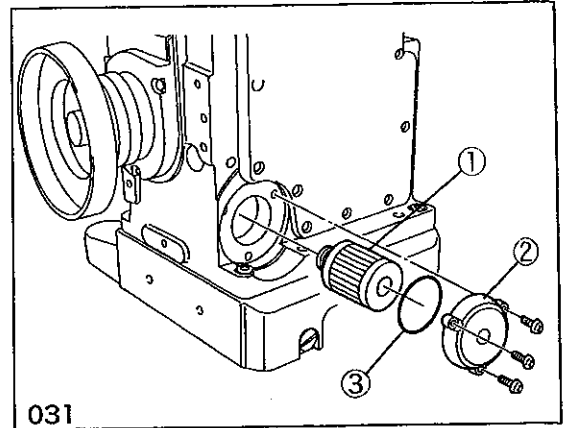

#### Check and replace

- ◇ Remove the oil filter cap ②, pull out the O-ring ③ and the oil filter ①, and check the oil filter.
- ◇ If the oil filter ① is clogged with dirt, clean or replace with a new filter.
- ◇ If the oil filter ① is broken, replace with a new filter.

#### **⚠ CAUTION**

- When removing the oil filter cap ②, oil in the oil filter ① may spill out.
- Insert the oil filter ① into the inmost to install it properly.

# 5. Proper operation

## 5.1 Detaching/reattaching cylinder front cover

### Detaching

Slide out the cylinder front cover ① towards your side.

### Reattaching

Align the cylinder front cover ① with the pins and slide it onto the sewing machine until hearing it clicks.

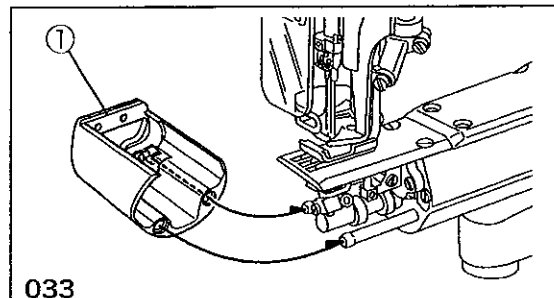
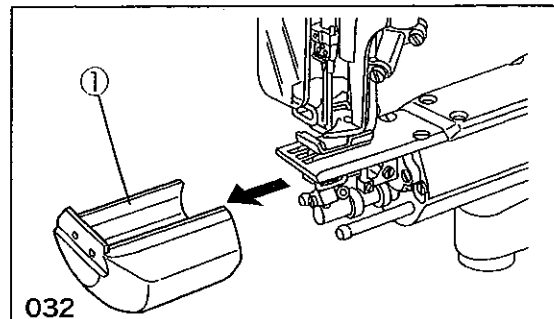

**⚠ CAUTION**  
Be sure to set the cylinder front cover ① during sewing procedure for safety use.

## 5.2 Needle system

Proper needle system for this sewing machine is UY x 128GAS needles.

Select a proper needle in size according to type and thickness of the fabric.

Table 3

Japanese standard	8	9	10	11	12	13	14
Metric standard	60	65	70	75	80	85	90

## 5.3 Needle installation

**⚠ CAUTION**  
Turn off the power switch of the motor and check the motor has stopped before installing needles. Working with the power on can result in injury.

- (1) Loosen the screws ③ that lock the needles ② in place with a screwdriver. To replace a needle ②, use tweezers to pull the old needle out.
- (2) Insert a new needle with facing its scarf to the right back to the end of the hole of the needle clamp ④, with tweezers.
- (3) Tighten the screws ③ to lock the needles ② in place.

**Notes**

- Use 0.6 N·m (6 kgf·cm) of torque to tighten the screws ③.
- After replacing a needle, check the distance between the needle and looper, and between the needle and needle guards (See pages 27 and 29).

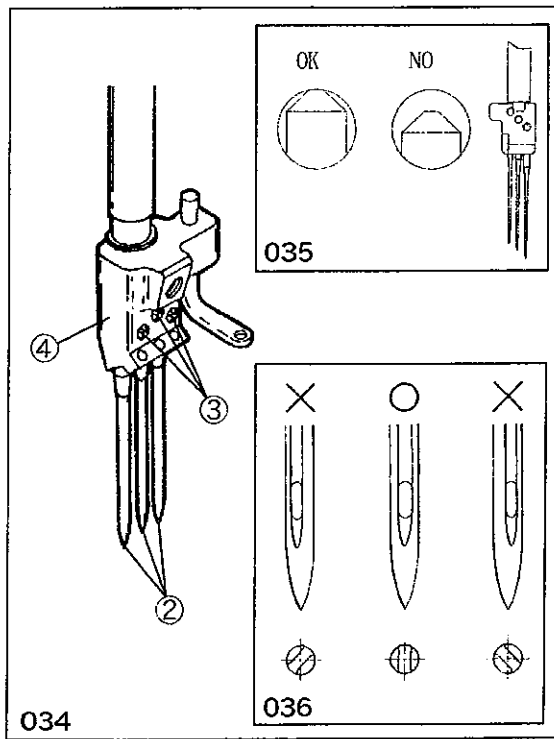

## 5. Proper operation

### 5.4 Threading



#### ⚠ CAUTION

- Turn off the power switch of the motor and check the motor has stopped before threading. Working with the power on can result in injury.
- Incorrect threading can cause skip stitch, thread breakage, and uneven stitch.

Thread as explained in Fig. 037.

#### ⓘ SUPPLEMENT

Raising the presser foot activates the tension release. This makes it easier to pull out the thread.

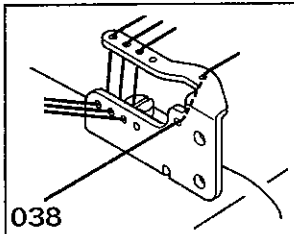

038

#### ⓘ SUPPLEMENT

If the needle threads need to be tightened, pass the threads through holes as shown in figure 038.

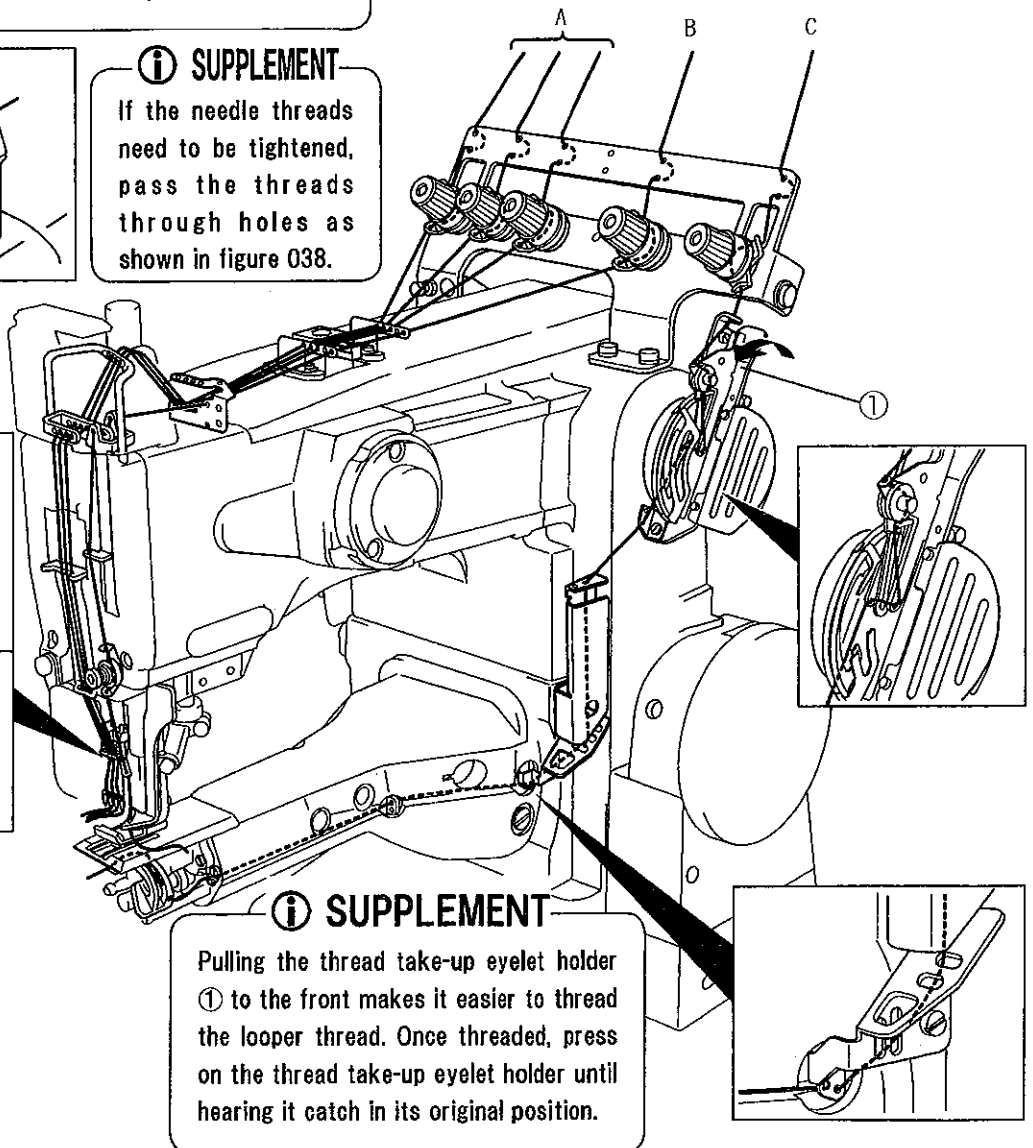
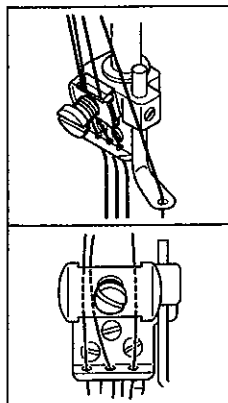

#### ⓘ SUPPLEMENT

Pulling the thread take-up eyelet holder ① to the front makes it easier to thread the looper thread. Once threaded, press on the thread take-up eyelet holder until hearing it catch in its original position.

If already threaded, tie them with new sewing threads.

<A: Needle threads>

Pull the thread knots to the front of needles, cut the knots off and rethread through the needles.

<B: Top cover thread>

Pull the thread until the knot comes out.

<C: Looper thread>

Pull the thread until the knot comes out, then cut the end with scissors.

037



### 5.5 Adjusting thread tension unit

Thread tension varies depending on the type of fabric, type of thread, sewing width, stitch length and conditions of use. Adjust thread tension from the individual thread tension spring caps.

- To tighten the thread tension, turn the caps clockwise.
- To loosen the thread tension, turn the caps counterclockwise.

- ① Left needle thread      ④ Top cover thread  
 ② Middle needle thread    ⑤ Loper thread  
 ③ Right needle thread

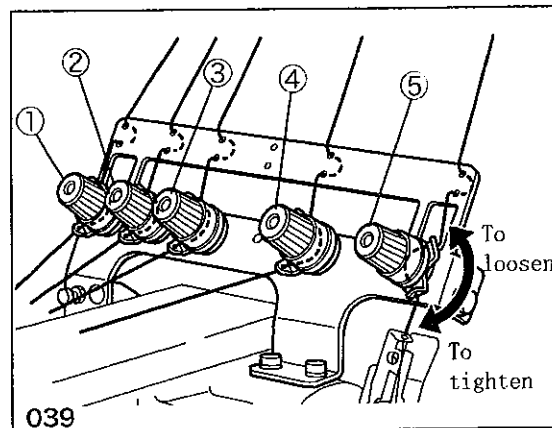

### 5.6 Presser foot pressure adjustment

Relieve presser foot pressure as much as possible within a range that keeps the stitch stable.

- (1) Loosen the lock nut ⑦ and turn the presser spring regulator ⑥.

- To increase the pressure, turn the regulator clockwise.
- To decrease the pressure, turn the regulator counterclockwise.

- (2) Once pressure has been adjusted, tighten the lock nut ⑦.

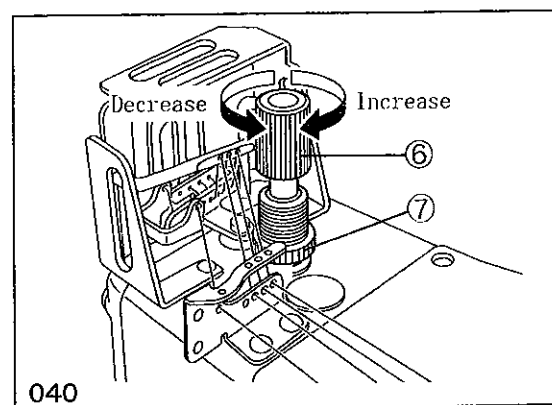

### 5.7 Differential feed adjustment

- (1) Loosen the lock nut ⑧.
- (2) Adjust differential feed with the differential lever ⑨.

- To make gathering, raise the lever.
- To make stretching, lower the lever.

\* Position the lever as suggested by the relationship between graduations and differential ratio in Table 4.

- (3) Once differential ratio has been adjusted, tighten the lock nut ⑧.

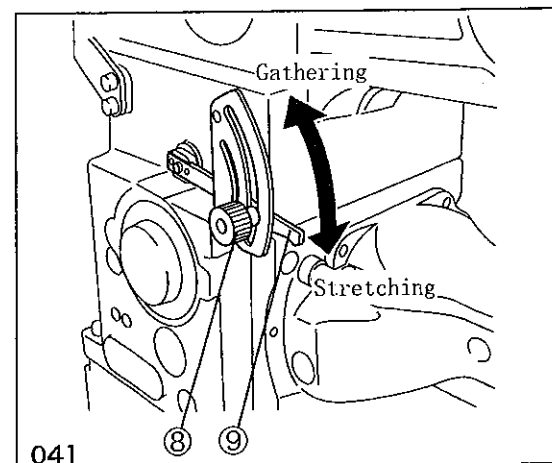

### CAUTION

- The differential ratio at the maximum stitch length of 4 mm is available up to 1:1.5
- At the maximum differential ratio of 1:2, the stitch length is 3 mm or less.

Table 4

Graduation	Differential ratio	Remarks
S	1:0.8	Stretching
1	1:1	
	1:1.5	Stitch length: 4mm or less
2	1:2	Stitch length: 3mm or less

## 5. Proper operation

### 5.8 Stitch length adjustment



#### ⚠ CAUTION

Turn off the power switch of the motor and check the motor has stopped before adjusting stitch length. Working with the power on can result in injury.

Stitch length can be adjusted infinitely from 1.2 mm to 4.0 mm.

Each graduation on the pulley indicates a stitch length (mm).

\* The actual length of the stitch may vary depending on the type and thickness of fabric, and differential ratio.

#### Changing Stitch Length

- (1) Press the pushbutton ① with your left hand until feeling the button tip contact the internal part.
- (2) With the pushbutton ① still depressed, turn the machine pulley to the front with your right hand. The pushbutton ① draws inward, therefore press the pushbutton ① forcefully.
- (3) With the pushbutton ① still depressed, align the scale marked on the machine pulley ③ with the mark ② on the hole of the belt cover.
  - To make the stitch length larger, turn the pulley clockwise.
  - To make the stitch length smaller, turn the pulley counterclockwise.
- (4) Once the marks are aligned, release the pushbutton ①.

#### ⚠ CAUTION

Check that the pushbutton ① has returned to its original position and that the machine pulley ③ rotates smoothly.

Table 5

Stitch length (mm)	Number of stitches per inch	Number of stitches per 30mm
4.0	6	7.5
2.5	10	12
2.0	12.7	15
1.2	21	25

◇ Table 5 shows the number of stitches per inch and 30 mm converted into stitch length.

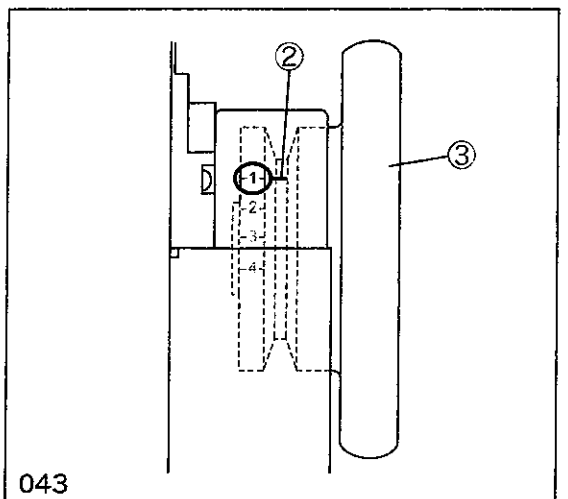
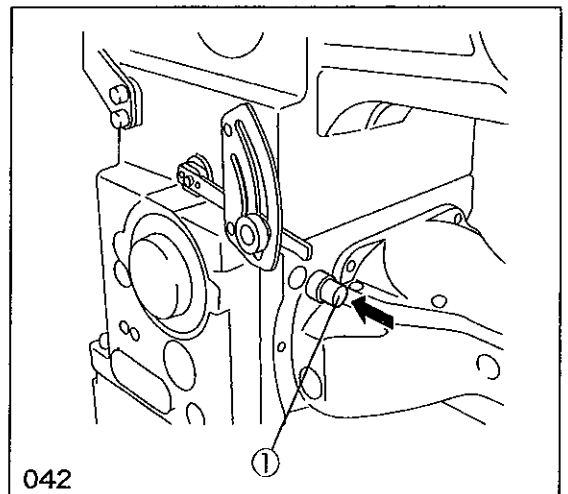

## 5.9 SP device



To prevent thread breakage and skip stitch in high speed sewing or when using synthetic thread or fabric, be sure to use the SP device. The device uses (dimethyl) silicon oil.

### Checking points before use

Remove the seal plug ② from the SP container ① and check the amount of (dimethyl) silicon oil. If oil level is low, add (dimethyl) silicon oil.

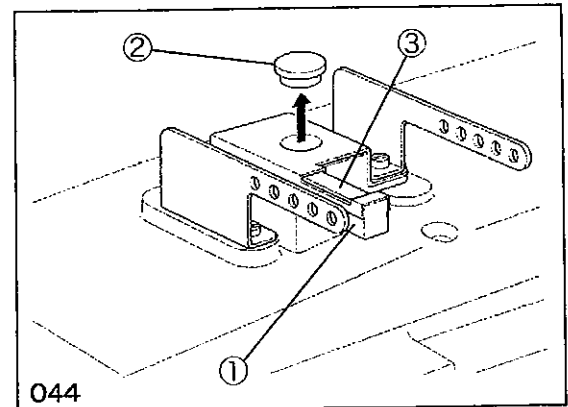

### ⚠ CAUTION

- If not using the SP device, remove the felt ③ from the device. If left inside, it may adversely affect sewing condition.
- If (dimethyl) silicon oil is adhered to other than the SP device, be sure to wipe it off. Adhering (dimethyl) silicon oil can result in sewing machine breakdown.

## 5.10 Using Presser Foot Release Lever

To remove sewn pre-closed materials, perform maintenance or clean the machine while keeping the presser foot up, move the presser foot release lever ④. The presser foot can be locked at the highest position.

This is also useful for reducing fatigue.

- To lock the presser foot at the highest point, push down the presser foot release lever ④ fully.
- To unlock and lower the presser foot, raise up the presser foot release lever ④ fully.

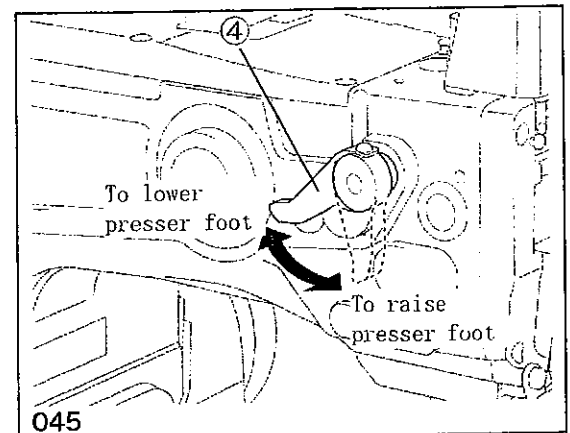

### ⓘ SUPPLEMENT

Turning the presser foot release lever ④ while toeing down the presser lifter pedal makes it easier to move the presser foot.

## 5.11 Fabric edge guide adjustment



### For hemming

The fabric edge guide(right) ① adjusts the fold width of the fabric.

- (1) Loosen the screws ② and slide the fabric edge guide(right) ① to the left and right until properly positioned.

\* To greatly reposition the guide, use other screw holes ③.

- (2) Tighten the screws ②.

The fabric edge guide(left) ④ adjusts the left edge of the folded fabric.

- (1) Loosen the screw ⑤ and slide the fabric edge guide(left) ④ to the left and right until properly positioned.

- (2) Tighten the screw ⑤.

### For tip over covering seam

- (1) Loosen the screws ⑧ of the fabric guide.
- (2) Insert the seam between the fabric guide(right) ⑥ and fabric guide(left) ⑦.
- (3) Position the seam at the center of the right needle and adjust the clearance between the fabric guide(right) ⑥ and fabric guide(left) ⑦ to feed the fabric smoothly.
- (4) Once the clearance has been adjusted, tighten the screws ⑧.

### ① SUPPLEMENT

The positional relationship between the aligned fabric edges and the right needle varies depending on the design of the garment.

### For covering seam

- (1) Loosen the screws ⑩ of the fabric guide.
- (2) Spread open the fabric seam, position the seam at the center of the needle distance and adjust the clearance between the fabric guide(right) ⑨ and fabric guide(left) ⑩ to feed the fabric smoothly.
- (3) Once the clearance has been adjusted, tighten the screws ⑩.

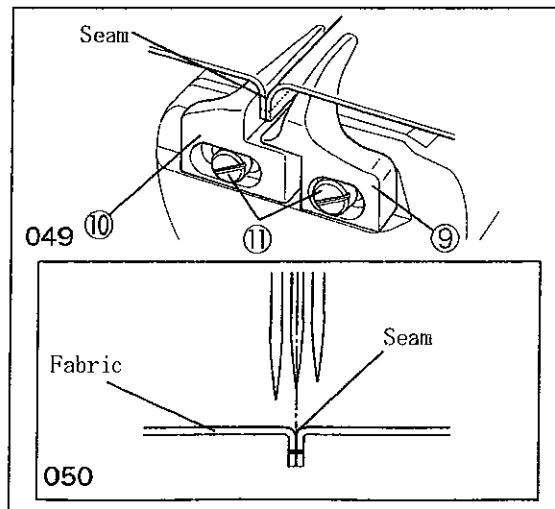
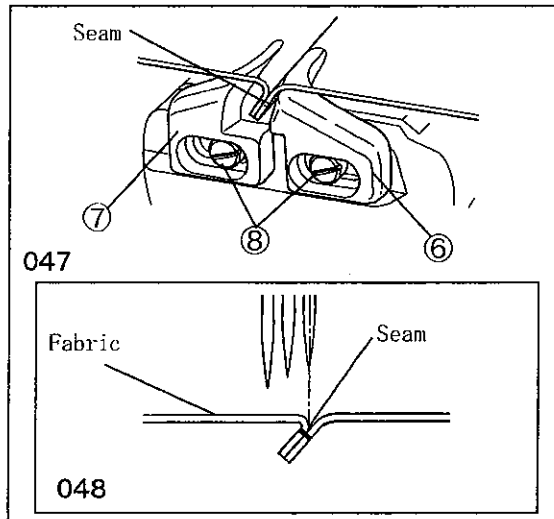
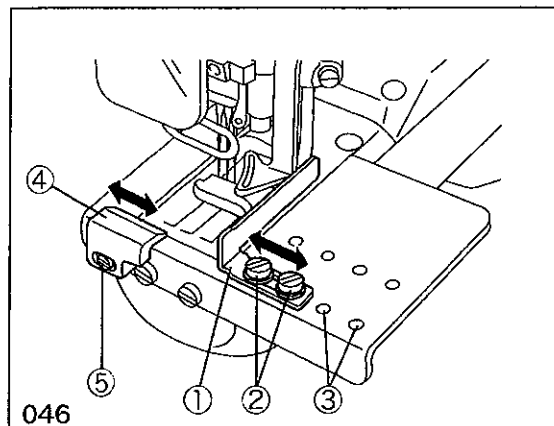

## 5.12 Cleaning



### CAUTION

Shut off power to the motor and check motor rotation has stopped before cleaning. If power is on, hands or clothing may become entangled whereby resulting in injury.

- ◇ At the end of work everyday, remove the cylinder front cover and clean away dust and lint accumulated in the sewing machine.
- ◇ Once a week, remove the cylinder front cover and the presser foot to clean the grooves in the stitch plate and the feed dog area.

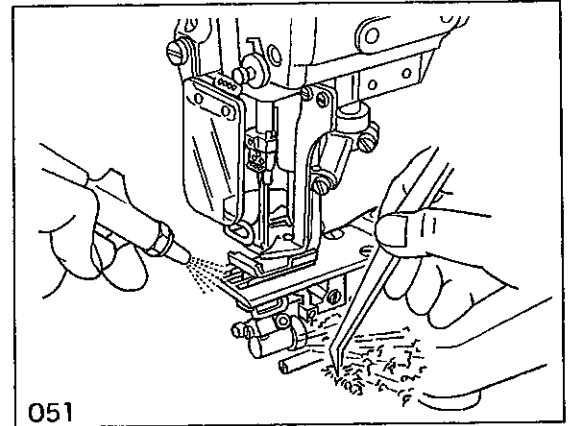

# 6. Machine adjustment

## ⚠ CAUTION

Turn off the power switch of the motor and check the motor has stopped before making adjustment.

### 6.1 Needle thread tension adjustment

#### Needle thread eyelet (front) adjustment

The tension of the needle threads can be adjusted with the needle thread eyelet (front) ①. In the standard position, the distance between the top surface of the arm ⑪ and the top surface of the needle thread eyelet (front) ① is 40 mm.

Loosen the screws ② to adjust the needle thread eyelet (front) ①. Once the eyelet has been positioned, tighten the screws ②.

- To loosen the needle thread, lower the needle thread eyelet (front).
- To tighten the needle thread, raise the needle thread eyelet (front).

#### Needle thread strike-off pin adjustment

The size of the needle thread loops can be adjusted with the needle thread strike-off pins ③ ④ ⑤. While the needle thread strike-off pins ③ ④ ⑤ are in the standard positions, the top of the needle bar thread eyelet ⑥ becomes flush with the bottom of the recess of the pins when the needle bar reaches the lowermost position. (See Fig. 053.)

Loosen the screws ⑦ to adjust the needle thread strike-off pins ③ ④ ⑤. Once the pins have been positioned, tighten the screws ⑦.

- To make loop smaller, lower the needle thread strike-off pin.
- To make loop larger, raise the needle thread strike-off pin.

#### Holder adjustment

After changing the type of thread, the position of the holder ⑧ needs to be moved and the size of the loops of the all needle threads needs to be adjusted.

Loosen the screws ⑨ ⑩ to adjust the holder ⑧. Once the holder has been positioned, tighten the screws ⑨ ⑩.

- To make loop smaller, lower the holder.
- To make loop larger, raise the holder.

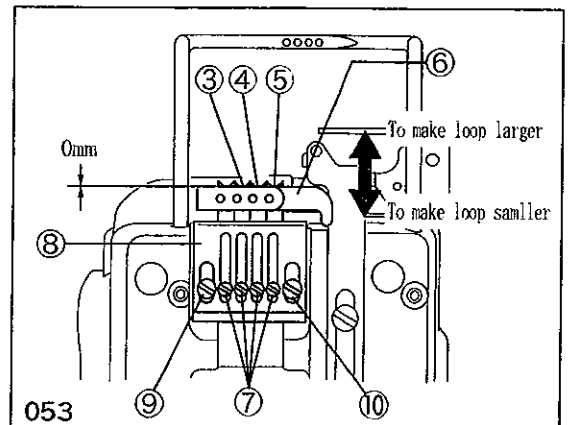
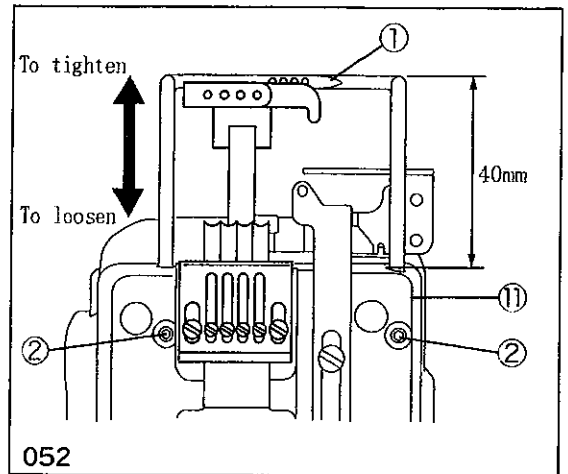

## 6.2 Top cover thread tension adjustment

In the standard position of the top cover thread take-up eyelet, the distance between the top surface of the arm and the top surface of the top cover thread take-up eyelet ① is 20 mm.

Loosen the screw ② to adjust the top cover thread take-up eyelet ①. Once the eyelet has been positioned, tighten the screw ②.

- To decrease take-up amount, lower the top cover thread take-up eyelet.
- To increase take-up amount, raise the top cover thread take-up eyelet.
- \* When using wooly thread or other stretchable thread as the top cover thread, lower the top cover thread take-up eyelet ①.

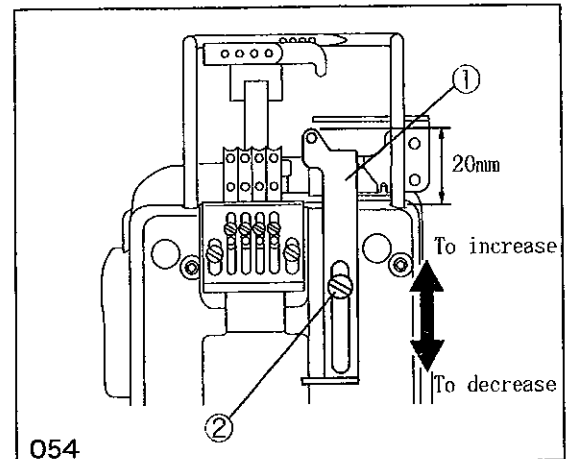

## 6.3 Looper thread tension adjustment

### Thread Take-up Eyelet Adjustment

The thread take-up eyelet ③ is at the standard position when the screw ④ is at the lowermost position of the slot.

Loosen the screw ④ to adjust the thread take-up eyelet ③. Once the eyelet has been positioned, tighten the screw ④.

- To decrease take-up amount, raise the thread take-up eyelet.
- To increase take-up amount, lower the thread take-up eyelet.

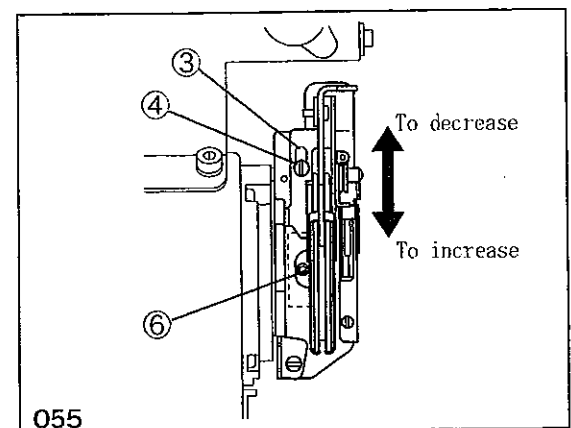

## ⚠ SUPPLEMENT

Too much take-up of looper thread can cause skip stitch.

### Looper Thread Take-up Adjustment

When the needle bar is at the highest point (top dead center), adjust the looper thread take-up ⑤ to the position where the looper starts taking up the thread. To adjust the position, loosen the set screw ⑥ of the looper thread take-up ⑤

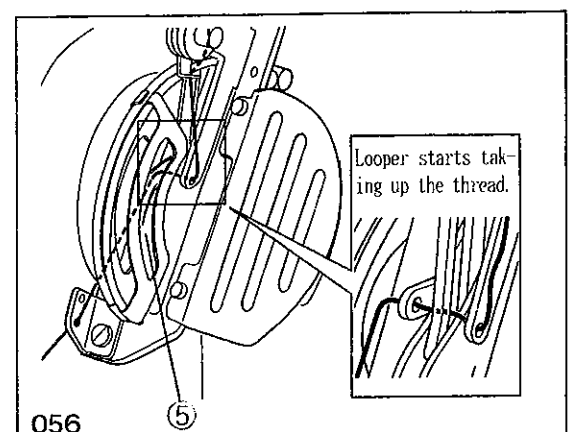

### 6.4 Needle and spreader adjustment

#### 6.4.1 Spreader adjustment

- (1) Loosen the screw ③ of the spreader and the screw ④ of the spring holder. (See Fig. 057.)
- (2) Adjust the spreader ① so that the clearance between the left needle and the hook ② of the spreader ① is 0.5 - 0.8 mm. (See Fig. 058.)
- (3) Make adjustment so that the distance from the center of the left needle to the hook ② is 4.5 - 5.5 mm when the spreader ① is at the extreme left. Then, tighten the screw ④. (See Fig. 057 and 058.)
- (4) Make adjustment so that the distance from the top surface of the stitch plate to the bottom surface of the spreader ① is 11 - 12 mm. Then, tighten the screw ③. (See Fig. 057 and 059.)

#### ① SUPPLEMENT

Match the height of the spreader ① according to the needle distance within the adjustment range, so that the top cover thread can pass behind the right needle and be caught by the left needle.

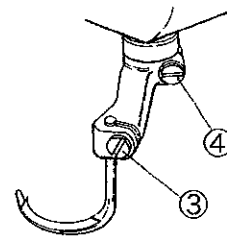

057

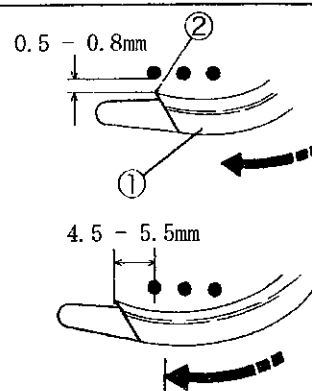

058

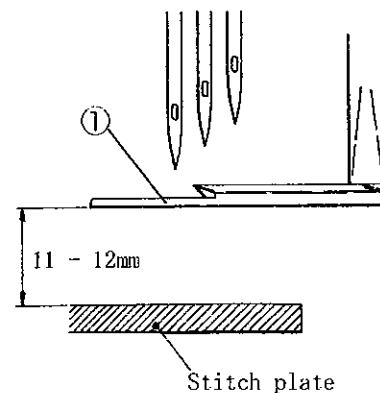

059



### 6.4.2 Top cover thread guide adjustment

- (1) Loosen the screws ② of the top cover thread guide ①. (See Fig. 060.)
- (2) Adjust the top cover thread guide ① so that the clearance between the top surface of the spreader ③ and the bottom surface of the top cover thread guide ① is 0.5 mm. (See Fig. 060.)
- (3) Adjust the spreader ③ so that the hook ④ is at the center of the slot on the top cover thread guide ① when the spreader ③ comes to the extreme right. Then, tighten the screws ②. (See Fig. 060 and 061.)

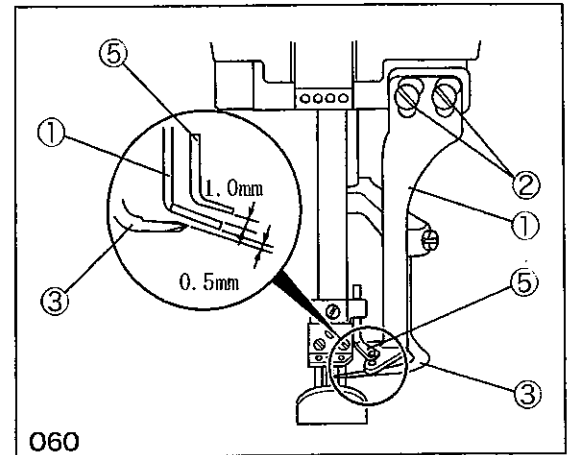

### 6.4.3 Top cover thread eyelet adjustment

- (1) Loosen the screw ⑥ of the top cover thread eyelet ⑤. (See Fig. 061.)
- (2) Adjust the top cover thread eyelet ⑤ so that the clearance between the top surface of the top cover thread guide ① and the top cover thread eyelet ⑤ is 1.0 mm when the needle bar is at the lowest point. (See Fig. 060.)
- (2) Align the hole of the top cover thread eyelet ⑤ to the extension from the slot on the top cover thread guide ①. (See Fig. 061.)
- (4) Tighten the screw ⑥. (See Fig. 061.)

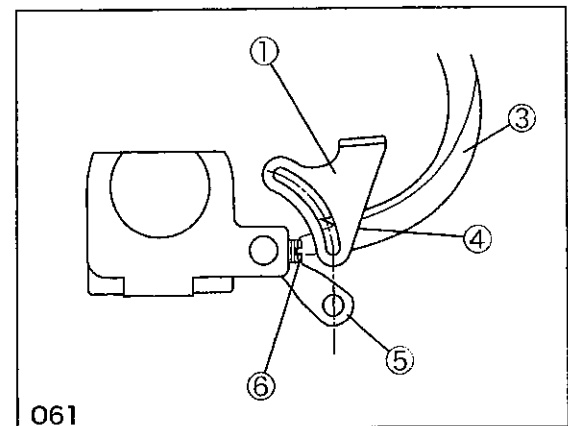

## 6. Machine adjustment

### 6.5 Needle and looper adjustment

#### 6.5.1 Looper and needle distance

The distance (L) from the tip of the looper ① to the center of the right needle when the needle is at the lowest point and the looper ① is at the extreme right varies depending on needle distance. Adjust the distance as shown in Table 6.

Loosen the screw ③ on the looper holder ② and the screw ⑤ on the looper holder collar ④ to adjust the position of the looper ①.

Once the looper has been positioned, tighten the screws ③ and ⑤.

#### ① SUPPLEMENT

Even though the needle distance is different, the distance from the center of the needle bar to the tip of the looper ① is 6.3 mm (6.2 - 6.4 mm.) (See Fig. 064.)

#### 6.5.2 Looper angle and height

Insert the looper ① to the end of the looper holder ② and tighten the screw ⑥. Looper height and looper installation angle ( $2^\circ$ ) will be fixed.

#### 6.5.3 Looper front-and-rear position

- (1) Turn the machine pulley until the tip of the looper ① comes to the center of the left needle ⑦.
- (2) Loosen the screws ③ ⑤ to adjust the looper holder ② together with the looper holder collar ④ so that the clearance between the backside of the left needle ⑦ and the tip of the looper ① is 0.2 - 0.3 mm.
- (3) Tighten the screws ③ ⑤.

#### ① SUPPLEMENT

Even though the set of the looper ① and the looper holder ② is removed, they can be reinstalled easily. Fit the pin of the looper holder collar ④ into the hole of the looper holder ②, press the parts together and tighten the screw ③ on the looper holder ②. Then, check the clearance between the needle and the looper ①.

#### ⚠ CAUTION

- Make the looper holder ② touch the looper holder collar ④ securely. If not, parts around the looper holder may be damaged.
- When tightening the screw ③, the looper ① may move in the front-and-rear position. After tightening the screw ③, recheck the front-and-rear position of the looper ①.

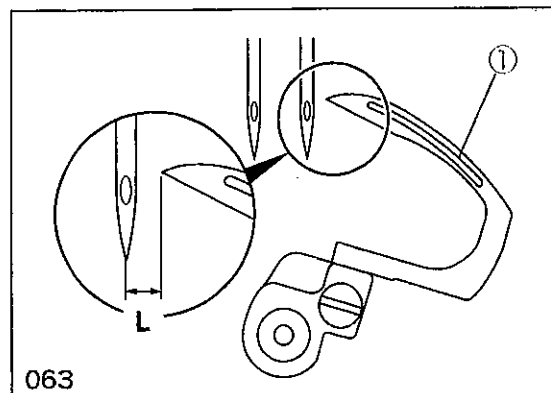
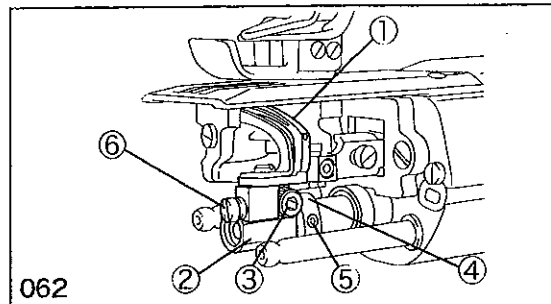
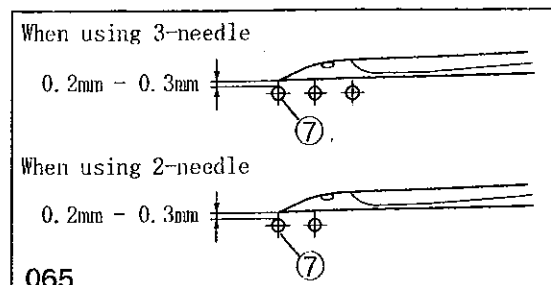
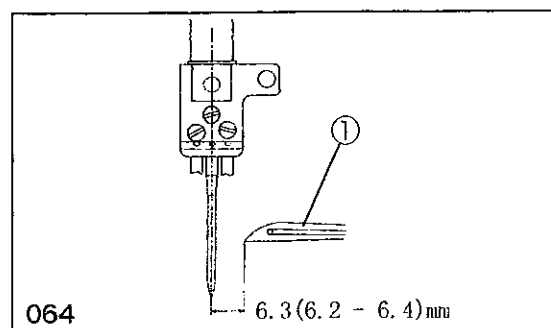

Table 6

Needle distance (code)	Looper and needle distance (L)
3.2 mm (32)	4.7 (4.6 - 4.8) mm
4.0 mm (40)	4.3 (4.2 - 4.4) mm
4.8 mm (48)	3.9 (3.8 - 4.0) mm
5.6 mm (56)	3.5 (3.4 - 3.6) mm
6.4 mm (64)	3.1 (3.0 - 3.2) mm



## 6.6 Needle height

- (1) Set the needle into the left needle installation hole of the needle clamp.
- (2) Remove the screw ①.
- (3) Loosen the screw ② of the needle bar bracket and adjust the needle bar in the vertical direction so that the tip of the left needle is the height (N) given in Table 7 from the stitch plate top surface.

This height varies depending on needle distance.

- (4) Check the needle drops in the center of the needle hole on the stitch plate, then tighten the screw ② of the needle bar bracket.
- (5) Retighten the screw ①.

### CAUTION

Before retightening the screw ①, wipe the old gasket clean and coat with liquid gasket. Dirt can cause oil leakage.

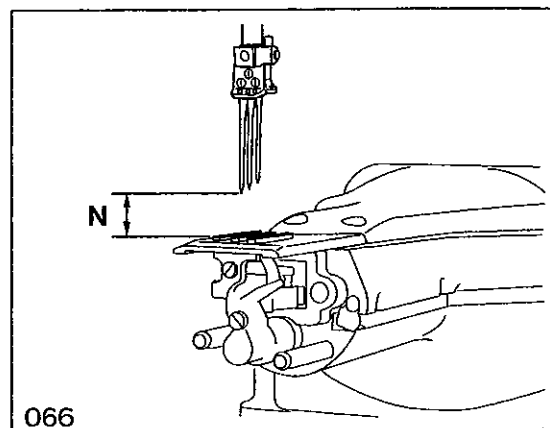
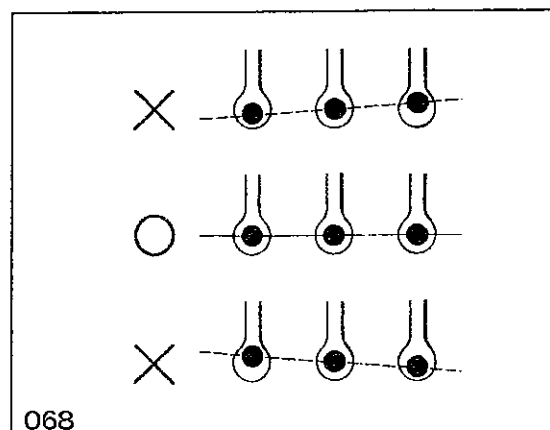
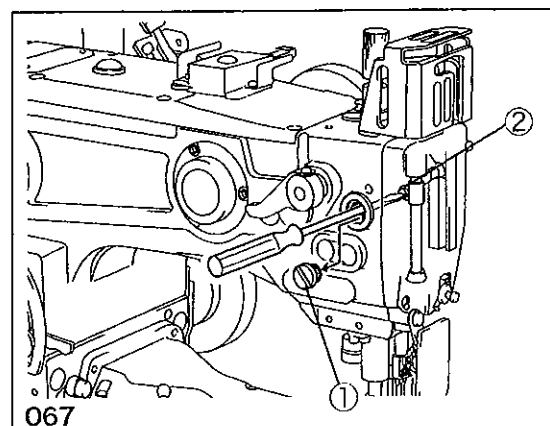

Table 7

Needle distance	Code	Left needle height (N)
3.2 mm	32	11.5(11.5 - 11.7)mm
4.0 mm	40	11.5(11.5 - 11.7)mm
4.8 mm	48	11.0(11.0 - 11.2)mm
5.6 mm	56	11.0(10.9 - 11.1)mm
6.4 mm	64	11.0(10.8 - 11.0)mm



## 6. Machine adjustment

### 6.7 Needle guard (rear) adjustment

#### Needle guard (rear) height

- (1) Loose the screw ②.
- (2) Set the ridge line "a" of the needle guard(rear) ① to the same height as the bottom of the left needle eye when the looper is at the center of the right needle.
- (3) Tighten the screw ②.

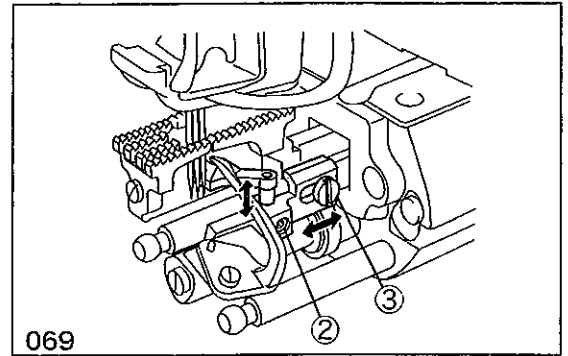

#### Needle guard (rear) front-and-rear position adjustment

- (1) Loosen the screws ② ③.
- (2) When the looper tip is at the center of the right needle, the looper pushes the right needle, therefore the right needle will be pushed by the needle guard(rear) ①, and the clearance between the needle and the looper will be 0 - 0.05 mm. Also at this time, adjust the angle and front-and-rear position of the needle guard(rear) so that the clearance between the left needle and the needle guard(rear) ① is 0 - 0.05 mm.
- (3) Check that the middle and left needles start contacting the needle guard(rear) at a point below the needle eye.
- (4) Tighten the screws ② ③.

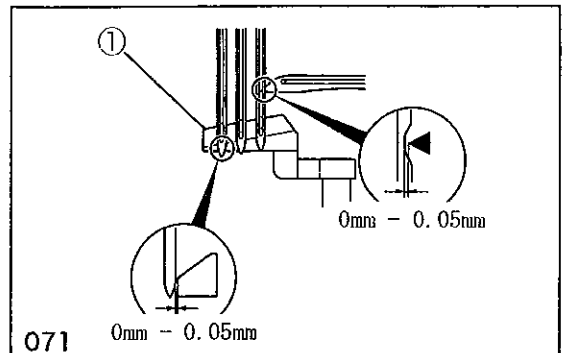
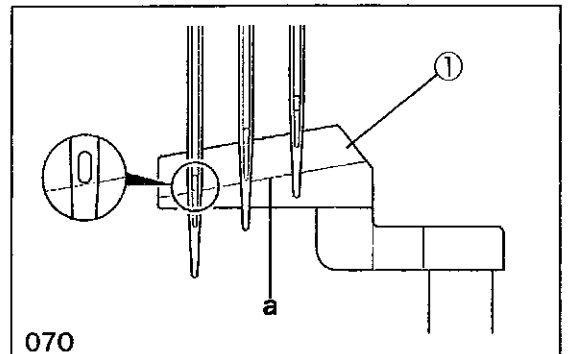

### 6.8 Needle guard (front) adjustment

- (1) Loosen the screw ⑤ and position the needle guard(front) ④ so that the clearance between it and each needle is 0 - 0.3 mm when the looper tip comes to the center of the left needle.
- (2) Tighten the screw ⑤.

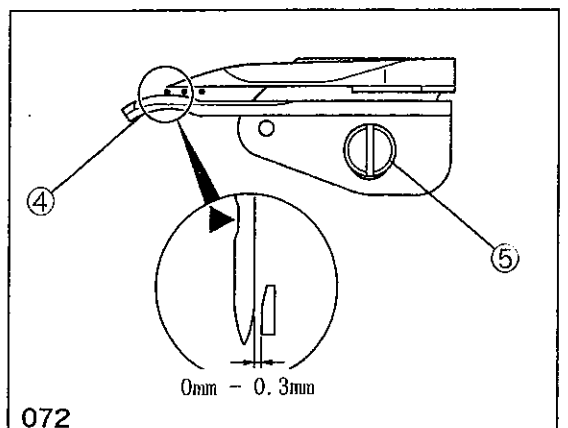

## 6.9 Feed dog height adjustment

### Standard position

When the feed dog is at the highest point, the tail end of the main feed dog ② is 1.2 - 1.4 mm from the top surface of the stitch plate. When the feed dog rises to the same height as the top surface of the stitch plate ⑦, the differential feed dog ① and the main feed dog ② are parallel to the stitch plate ⑦. Set the differential feed dog ①, middle feed dog ③ and main feed dog ② to the same height.

### Adjustment

Loosen the screw ④ of the differential feed dog ①, the screw ⑤ of the main feed dog ② and the screw ⑥ of the middle feed dog ③, and position the feed dogs. Once the feed dogs have been positioned, tighten the screws ④ ⑤ ⑥.

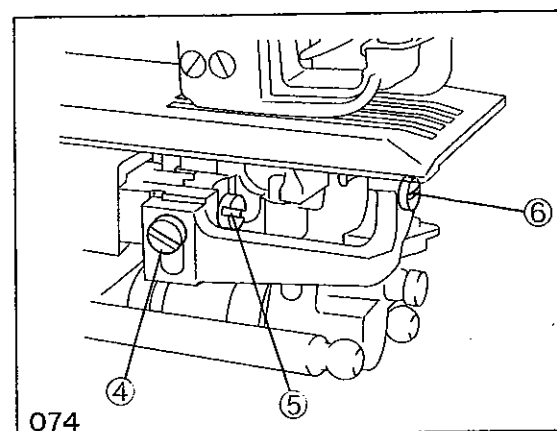
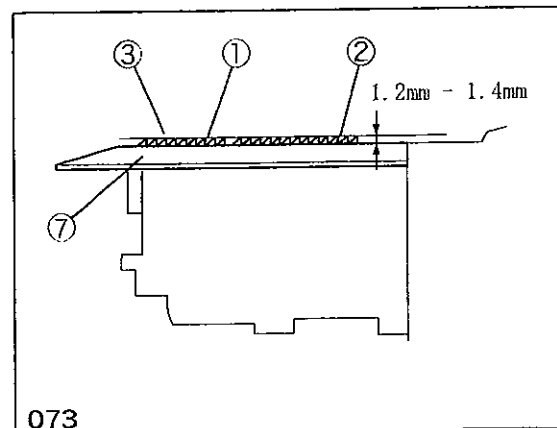

## 6.10 Presser foot position adjustment

Correctly set the presser foot ⑧ on the presser bar ⑨ and position the presser foot so that the needles ⑩ drop in the center of the needle hole ⑪. Loosen the screw ⑫ on the presser foot ⑧ and turn the presser foot ⑧ to the left and right until the needles ⑩ drop in the center of the needle hole ⑪ on the presser foot ⑧.

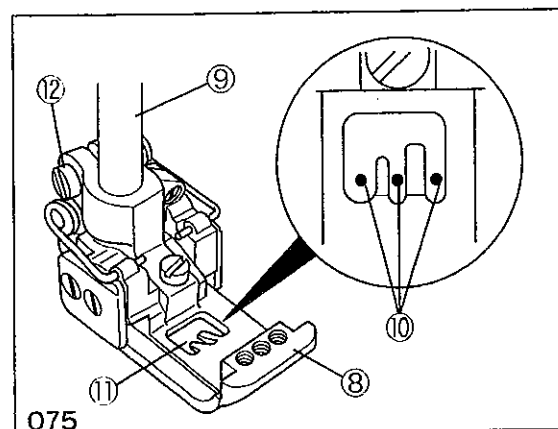

## 6. Machine adjustment

### 6.11 Presser foot stopper collar adjustment

Loosen the screws ③ and adjust the height of the presser foot stopper collar ② so that the gap between the presser bar bushing ① and the collar ② is 0.3 mm when the presser foot is at the topmost position.

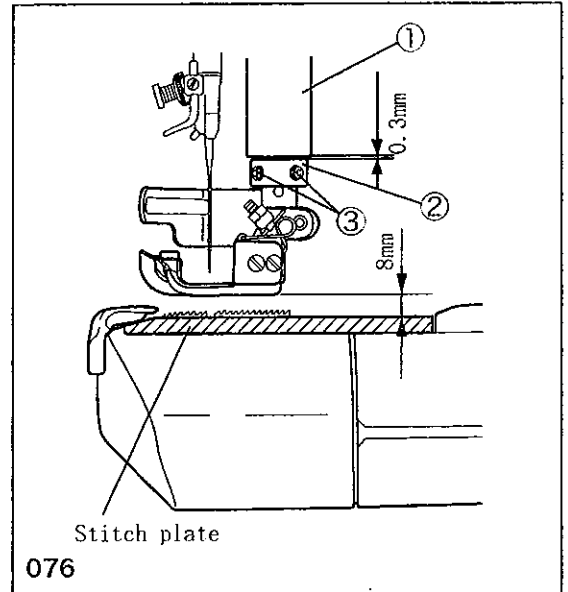

### 6.12 Detaching/reattaching presser foot



#### Detaching

- (1) Loosen the screw ④.
- (2) Press the lifter lever ⑥ downward and detach the presser foot ⑤.

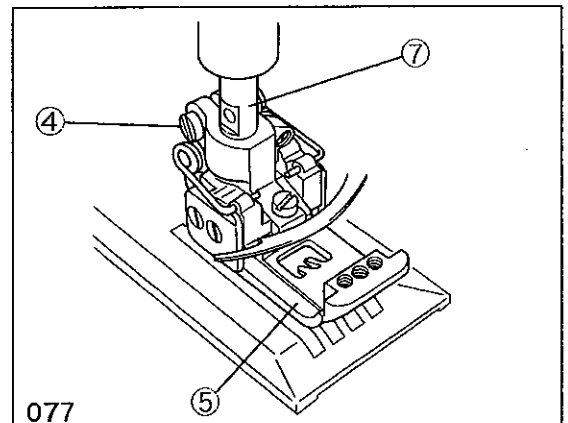

#### Reattaching

- (1) Press the lifter lever ⑥ downward, and insert the presser foot ⑤ into the presser bar ⑦.
- (2) Position the presser foot ② as explained in "6.10 Presser Foot Position Adjustment" (page 30), and tighten the screw ④.

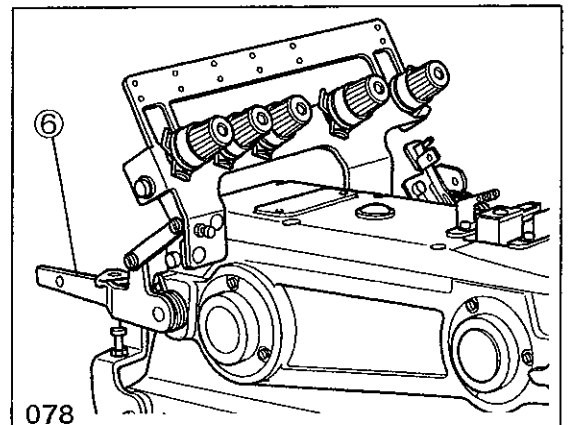

# 7. Troubleshooting

Trouble	Check item	Remedial action	Ref. page
Skip stitch	Is the thread wrongly threaded?	String the thread properly.	17
	Is the needle bent or the tip broken?	Replace the needle.	16
	Is the thread too much tightened?	Loosen the thread by the tension unit.	18
	Are the timing and clearances of the needles, looper and needle guards correct?	Correct the timing and clearances of the needles, looper and needle guards.	27 ~ 29
	Is the needle too thin for the thread?	Either replace the needle or the thread with the proper size.	16
	Is the needle wrongly attached (direction or insertion depth)?	Attach the needle correctly.	16
Thread breakage	Is the thread caught on the eyelet?	Remove the caught thread.	
	Is the thread wrongly threaded?	String the thread properly.	17
	Is the thread too much tightened?	Loosen the thread at the tension unit.	18
	Is the needle too thick for the thread?	Either replace the needle or the thread with the proper size.	16
	Is the thread good quality?	Use a good quality thread.	
	Did the thread break under heat?	Use the SP device.	20
	Is there damage on eyelet, looper thread take-up, etc?	Either repair the damage or replace with a new part.	
Needle breakage	Did the needle contact the looper?	Correct the clearances of the needles, looper and needle guards.	27 · 29
Improper thread tension	Is the thread wrongly threaded?	String the thread properly.	17
	Are the needle threads and looper thread properly balanced?	Correct the balance at the tension unit.	
Uneven tension	Is the thread wrongly threaded?	String the thread properly.	17
	Are the needle threads and looper thread properly balanced?	Correct the balance at the tension unit.	
Oil does not come from nozzle	Is oil level below the line on the oil gauge?	Add oil.	13 · 14
	Is the oil filter clogged?	Replace the oil filter.	15

# 8. Specifications

Description	3-Needle Cylinder Bed Interlock Stitch Machine
Dimensions	430mm (L) × 284mm (W) × 360mm (H)
Cylinder circumference	160mm
Weight	42kg
Stitch type	ISO 406, 407, 602, 605
Application	Plain stitch, overlapped seam, hemming and welt seam for knitted fabrics
Sewing speed	Max. 4500rpm (during intermittent operation)
Stitch length	Number of stitches (1.2 - 4mm) 6 - 21 stitches/inch (25.4mm) 7.5 - 25 stitches/30mm
Needle system	UY×128GAS #9 - #14 (Standard #10) (65 - 90)
Needle distance	3-needle : 4.8mm, 5.6mm, 6.4mm (2-needle : 3.2mm, 4.0mm)
Needle stroke	31.5mm
Presser foot lift	8mm (with spreader)
Feed regulation	Pushbutton system
Differential ratio	Max. normal differential 1:2, Max. reverse differential 1:0.8
Differential feed regulation	External lever
Lubrication	Automatic lubrication by trochoid-shaped pump
Lubricating oil	YAMATO SF OIL No. 28
Capacity of oil reservoir	600mL
Installation	"Table top installation" or "Semi-submerged installation"



***Yamato***

ヤマトマシン製造株式会社

***YAMATO SEWING MACHINE MFG. CO., LTD.***

4-4-12, NISHITENMA, KITA-KU, OSAKA, JAPAN

TEL: 81-6-6364-1321 FAX: 81-6-6364-1307

〒530-0047 大阪市北区西天満4丁目4番2号

TEL (06) 6364-1321(代) FAX (06) 6365-5176

# ***Yamato***<sup>®</sup>

## **Instruction Manual**

PNEUMATIC UNDER THREAD TRIMMING DEVICE  
controlled by compact motor

---

### **UT-A/Y, UT-A**

UT-A34/ST-2A/Y, UT-A34/ST2-A

---

VT2500 class

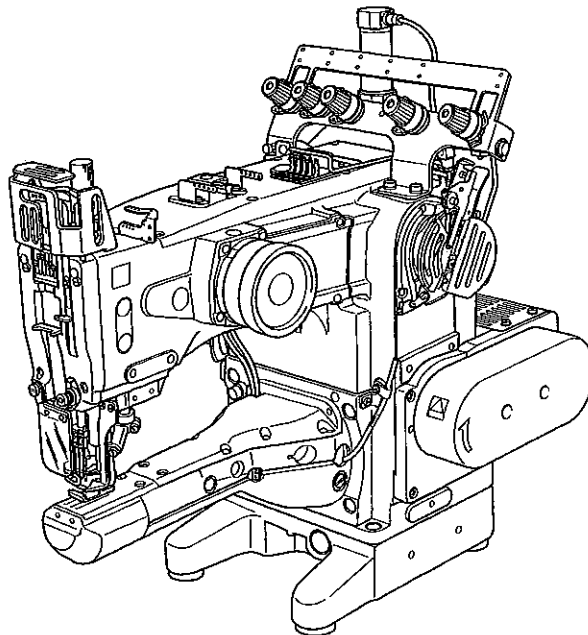

Thank you for purchasing UT-A/Y, UT-A.

Before using your UT-A/Y, UT-A, please read the instruction manual and understand the contents well.

After reading the instruction manual, please keep it in a location where it is easily accessible to the operator.





 **YAMATO SEWING MACHINE MFG. CO., LTD.**

# CONTENTS

---

<b>1. Introduction</b>	<b>1</b>
1.1 Outlines	1
1.2 Name of each part	1
<b>2. Installation</b>	<b>2</b>
2.1 Table cutting diagram (UT-A34/Y with Y motor)	2
2.2 Installing compact servomotor	3
2.3 Installing solenoid valve and presser foot lifter cylinder	3
2.4 Installing thread tension	4
2.5 Air piping diagram	5
2.6 Wiring	6
2.6.1 Wiring motor	6
2.6.1.1 UT-A34/Y (with Y motor)	6
2.6.1.2 UT-A34 (without Y motor)	7
2.6.2 Connecting detector switch	8
2.6.3 Connecting intermediate cable	8
2.6.4 Solenoid valve number and intermediate cable part number	8
2.7 Setting motor	9
2.7.1 UT-A34/Y (with Y motor)	9
2.7.1.1 Simple setting	9
2.7.1.2 Setting sewing speed	10
2.7.1.3 Disabling thread cutting function	11
2.7.2 UT-A34 (without Y motor)	12
2.7.2.1 Simple setting	12
2.7.2.2 Setting sewing speed	13
2.8 Adjusting rotation detector unit	14
2.8.1 UT-A34/Y (with Y motor)	14
2.8.2 UT-A34 (without Y motor)	14

# CONTENTS

	<b>3. Proper operation</b>	<b>15</b>
	3.1 Treading	15
	3.2 Stitch length adjustment	16
	3.3 Operating procedure	17
	3.4 Removing and reinstalling stitch plate	18
	3.5 Regular maintenance (only for UT-A34/Y with Y motor)	19
	<b>4. Adjustment</b>	<b>20</b>
	4.1 Trimming knife mechanism	20
	4.1.1 Position of movable trimming knife	20
	4.1.2 Adjusting detector switch	22
	4.1.3 Thread clamp	23
	4.1.4 Movable trimming knife presser	23
	4.1.5 Relation between movable trimming knife, needle thread, and looper thread	24
	4.2 Tension release mechanism	25
	4.2.1 Tension release of needle thread	25
	4.2.2 Tension release of looper thread	26
	4.3 Presser foot lifter mechanism	27
	4.4 ST2-A device	28
	4.4.1 Position of movable trimming knife	28
	4.4.2 Engagement between movable and fixed trimming knives	29
	4.4.3 Pressure of thread clamp spring	30
	4.4.4 Adjusting thread pull-off hook unit	30
	4.5 Changing timing belt (only for UT-A34/Y with Y motor)	31

## Attention

◇ This instruction manual is designed mainly for technicians, but it is advisable that also operators read the instructions with  mark to use the machine properly.

◇ The numbers in lower left corners of figures are figure numbers. We use them in texts as needed for your reference.

## Attention

The parts used for this product are subject to change without notice. If such a change is made, any part of the contents and illustrations of this instruction manual may not conform to this product. In preparing the instruction manual, we have made our best efforts for making it free of any error or omission. If any error or omission should yet be found, it might not be rectified immediately.

# 1. Introduction

## 1.1 Outlines

### UT-A34

Pneumatic under thread trimmer

### ST2-A

Air operated top cover thread trimmer

### Y

A compact servomotor

A built-in (sewing machine) compact servomotor

### Notice

In this instruction manual, the description about installation, operation and adjustment may differ according to the type of motor.

○ In case of 「/Y」 which with compact motor model, it will be indicated as 「UT-A34/Y with Y motor」.

○ In case of Mitsubishi GY-100 motor, it will be indicated as 「UT-A34 without Y motor」.

## 1.2 Name of each part

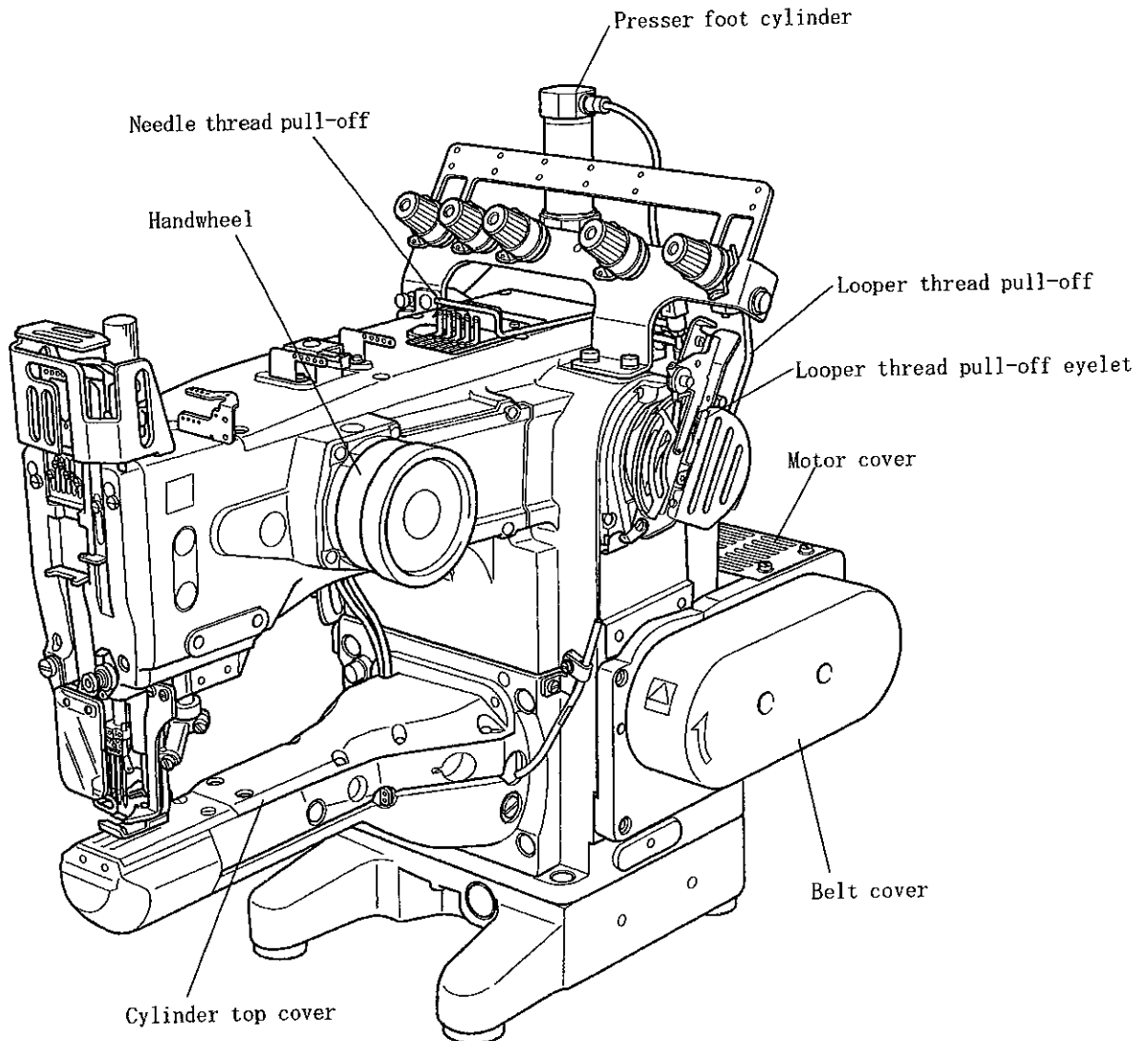

Fig. 1

# 2. Installation

## 2.1 Table cutting diagram (UT-A34/Y with Y motor)

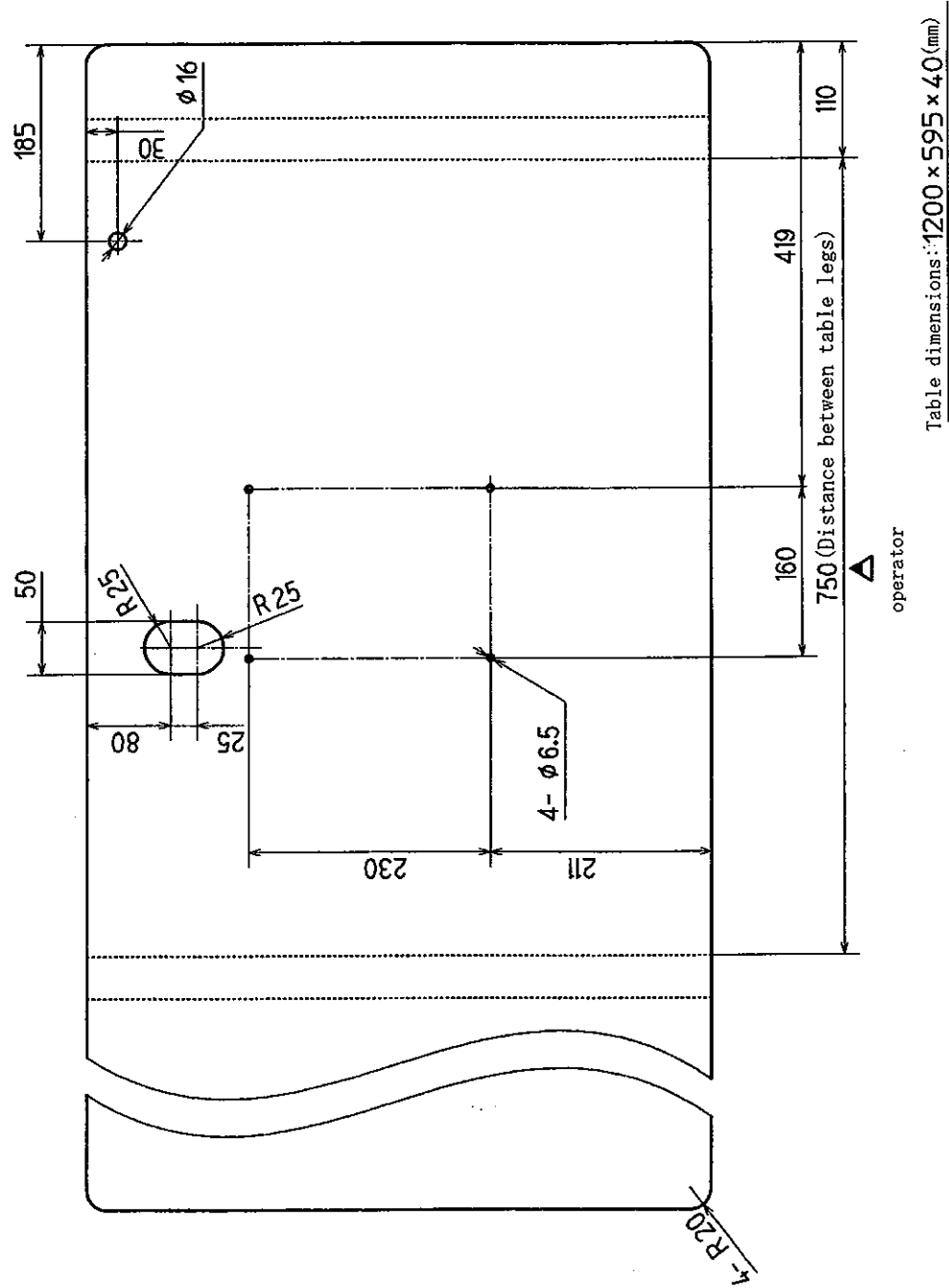

Fig. 2

## 2.2 Installing compact servomotor

1. Install the set of motor and motor bracket ① with the screw ②③.
2. Tighten the first screw ⑦ of motor adapter ⑥ on the rotation direction onto the flat part ⑤ on main shaft ④. Then, tighten the other screw ⑧.
3. Install the vertical belt cover (middle) ⑨.
4. Install the belt cover ⑩.

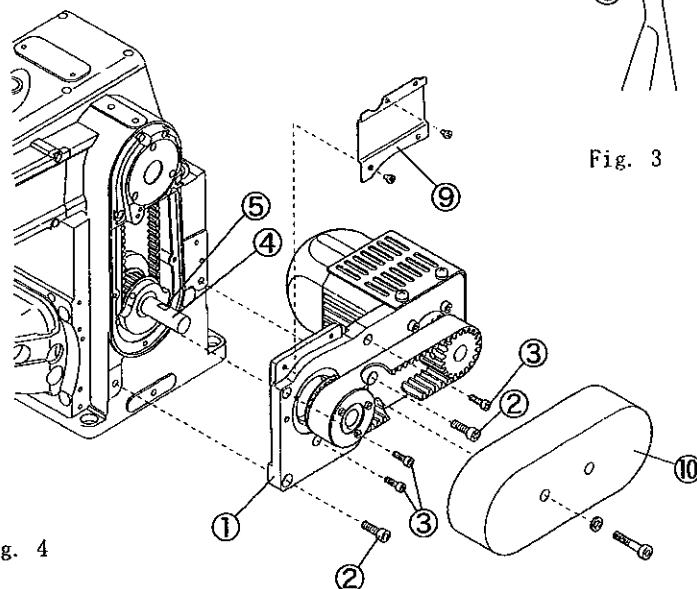

Fig. 4

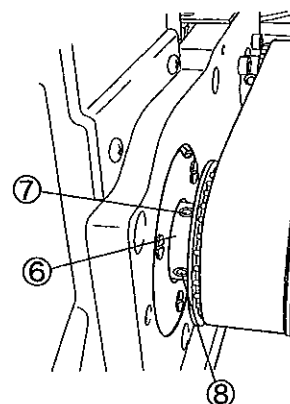

Fig. 3

## 2.3 Installing solenoid valve and presser foot lifter cylinder

Install solenoid valve and presser foot lifter cylinder, c. set ⑪ with the screw ⑫ and the washer ⑬ behind the sewing machine.

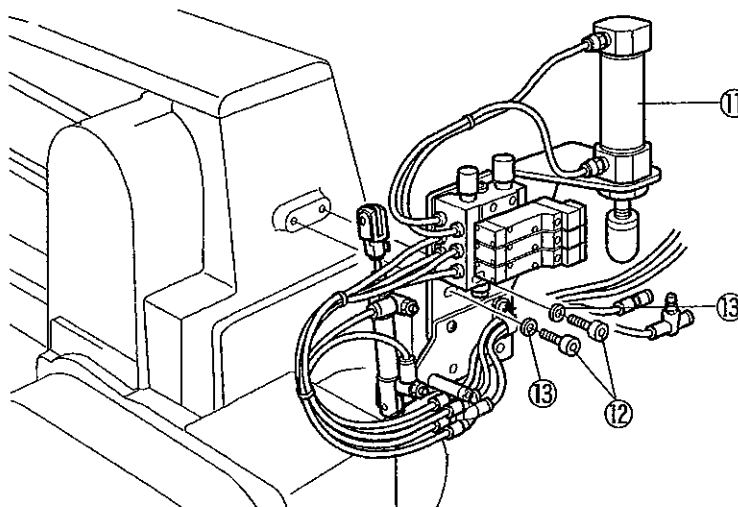

Fig. 5

## 2. Installation

### 2.4 Installing thread tension

- (1) Install needle thread pull-off (rear) ⑦ on thread pull-off holder ⑧.
- (2) Install looper thread pull-off ⑨ on thread pull-off holder ⑧.
- (3) Install thread tension ① on the upper part of the sewing machine with screws ② (two screws each, right and left) and washers ③ (two screws each, right and left).

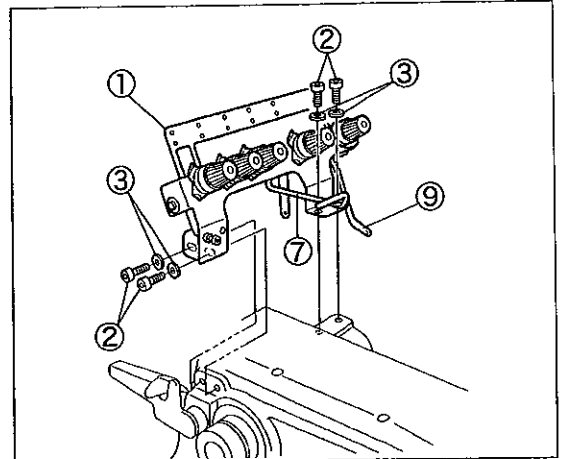

Fig. 6

- (4) Connect tension release cylinder ④ and tension release lever ⑤ by connecting pin ⑥.

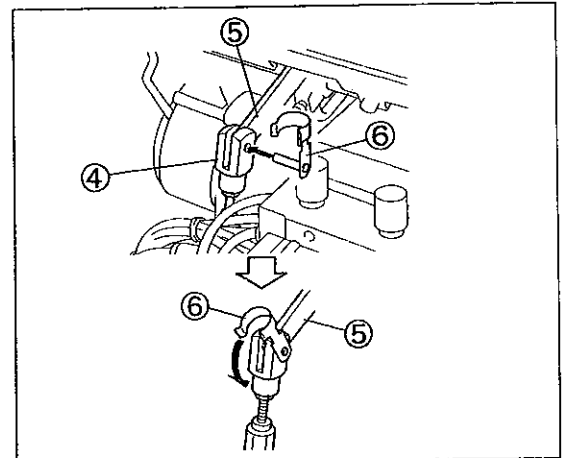

Fig. 7

- (5) Make adjustment of the needle thread pull-off (rear) ⑦.  
(Refer to "4.2.1 Tension release of needle thread")
- (6) Make adjustment of the looper thread pull-off ⑨.  
(Refer to "4.2.2 Tension release of looper thread")

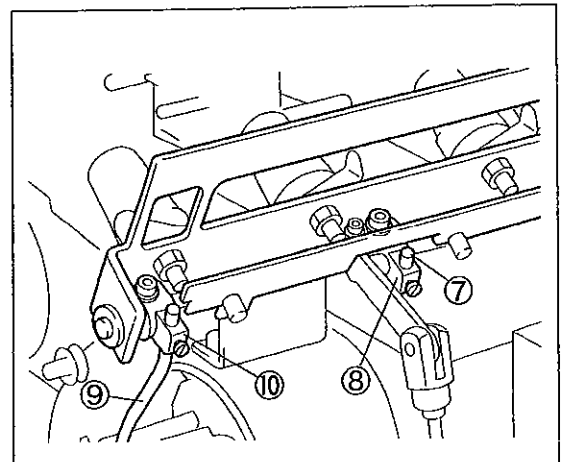

Fig. 8



## 2.5 Air piping diagram

Connect the pipe of the same number with the connector.  
Fix the air pipe referring to Fig. 9.

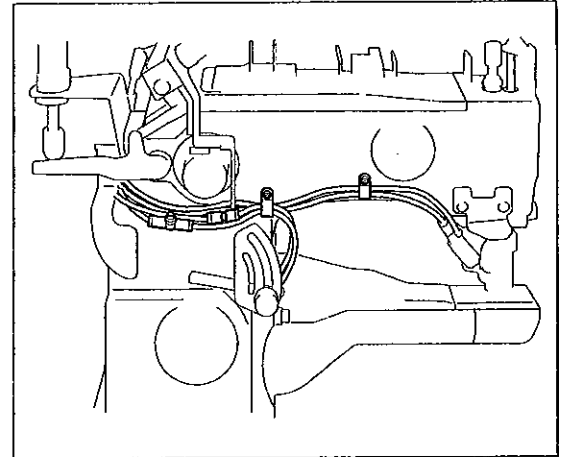
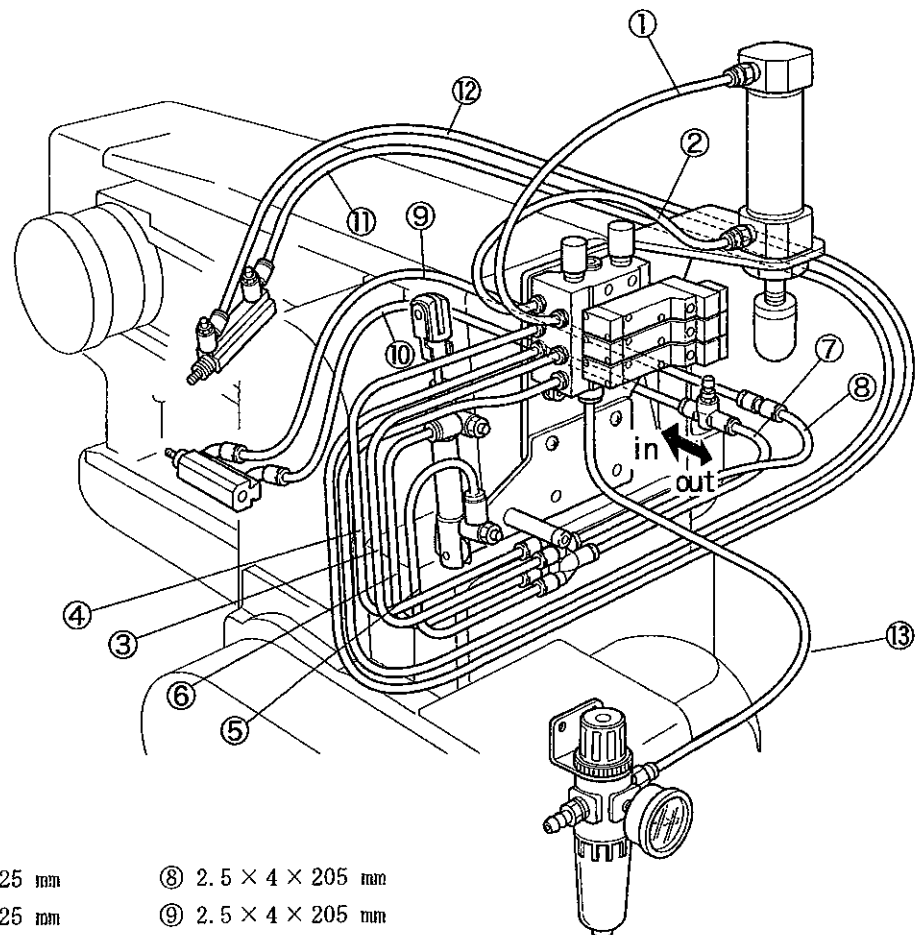

Fig. 9

UT-A34/ST2-A



- |                    |                    |
|--------------------|--------------------|
| ① 2.5 × 4 × 225 mm | ⑧ 2.5 × 4 × 205 mm |
| ② 2.5 × 4 × 225 mm | ⑨ 2.5 × 4 × 205 mm |
| ③ 2.5 × 4 × 225 mm | ⑩ 2.5 × 4 × 205 mm |
| ④ 2.5 × 4 × 225 mm | ⑪ 2.5 × 4 × 750 mm |
| ⑤ 2.5 × 4 × 225 mm | ⑫ 2.5 × 4 × 720 mm |
| ⑥ 2.5 × 4 × 225 mm | ⑬ 4 × 6 × 1500 mm  |
| ⑦ 2.5 × 4 × 205 mm |                    |

air pressure standard 0.4MPa(4kgf/cm)  
range of use 0.35~0.45MPa

Fig. 10

## 2. Installation

### 2.6 Wiring

#### 2.6.1 Wiring motor

##### 2.6.1.1 UT-A34/Y (with Y motor)

### ⚠ WARNING

To avoid electrical hazard, keep the power cable for the control box unplugged during wiring.

- Install the control box and the pedal unit on the back surface of the machine table referring to the instruction manual for the motor.
- Connect the control box, the pedal unit, the motor, and the rotation detector unit (synchronizer) referring to the instruction manual for the motor.

#### Connecting lamp

### ⚠ CAUTION

Never use the lamp other than the LED lamp (DC12V, 50mA). If used, it can cause the damage to the control box.

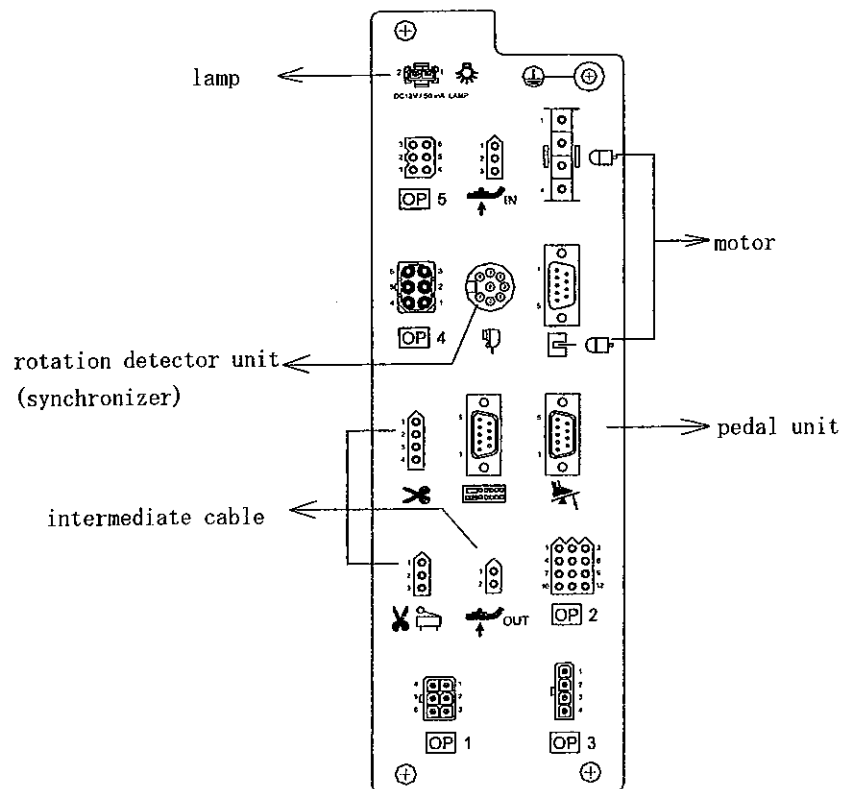

Fig. 11

### 2.6.1.2 UT-A34 (without Y motor)

#### WARNING

To avoid electrical hazard, do not connect the power cord to service outlet during wiring.

- Install the control box and the motor onto the machine table by referring to the instruction manual for the motor.
- For the connection of the control box, the motor, and the position detector (synchronizer), refer to the instruction manual for the motor.
- Connect each connector on control box with the one which is the same in color and shape from intermediate cable. Miss-connecting may cause damage to the sewing machine.

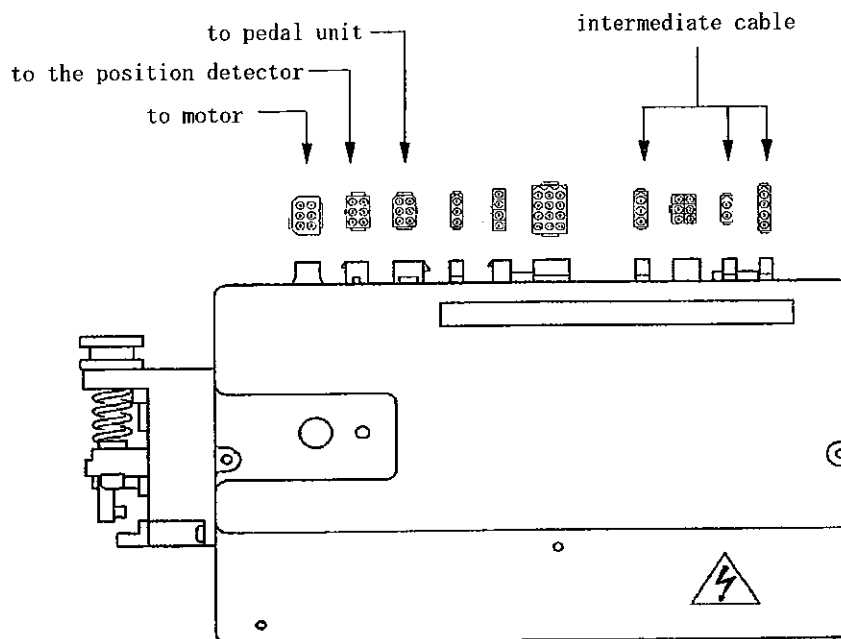

Fig. 12

## 2. Installation

### 2.6.2 Connecting detector switch

Connect the 3P-connector of the detector switch to that of the intermediate cable.

Refer to the figure to insert the R connector (1070199) properly according to the machine model or device in the position of figure.

#### **CAUTION**

1. Set the appropriate R connector to the machine model. R connector is limited by the safety, when improper R connector is connected, damage to the machine might be caused.
2. Without R connector, maximum sewing speed is set for 2000rpm. And the function is limited by the consideration in safety.

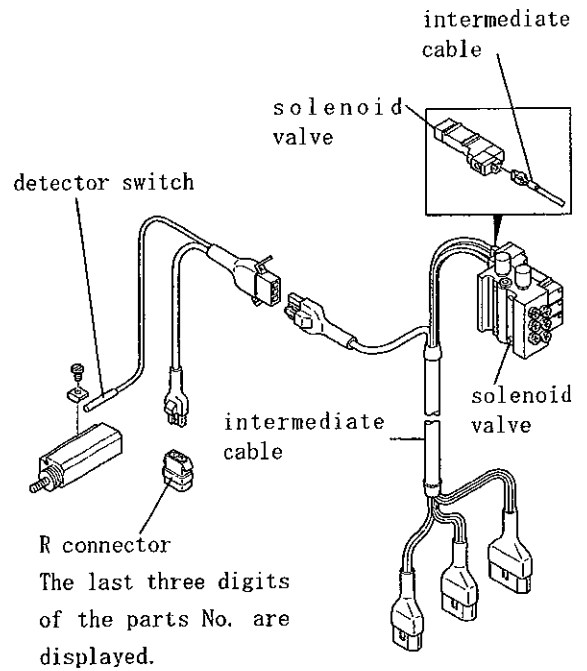

Fig. 13

### 2.6.3 Connecting intermediate cable

Insert the connectors of the intermediate cable to the solenoid valves until you hear them click.

### 2.6.4 Solenoid valve number and intermediate cable part number

device	looper thread cutter	tension releaser	presser foot lifter	air wiper	top cover thread cutter	intermediate cable part number
UT-A34/ST2-A	②		①	×	③	1200452

Table 1

Note 1 : The circled number shows the solenoid valve number.

## 2.7 Setting motor

### ⚠ CAUTION

Set the motor correctly according to the model and the device of the sewing machine. Improper setting can cause breakdown and damage.

### 2.7.1 UT-A34/Y (with Y motor)

#### 2.7.1.1 Simple setting

For main models, the setting for the motor can be changed in the following method. (Refer to table 2)

1. Turn on the power switch while holding down **P** key. LED displays "047.0RC".

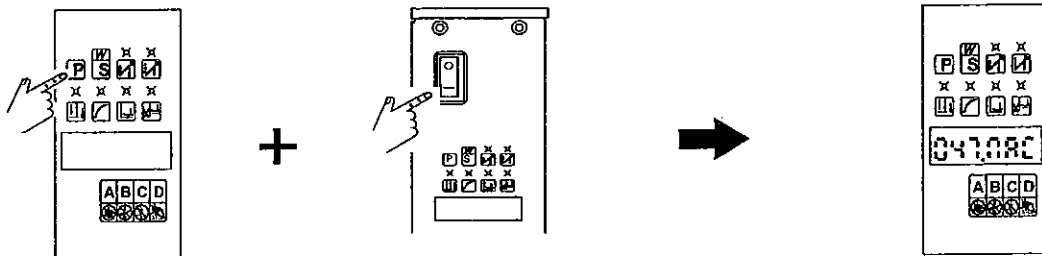

2. Press **S** key to display which is the current simple setting.

3. Press **C** or **D** key to change to new setting.

4. Press **S** key to change to new setting. And then, it return to "normal mode" automatically.

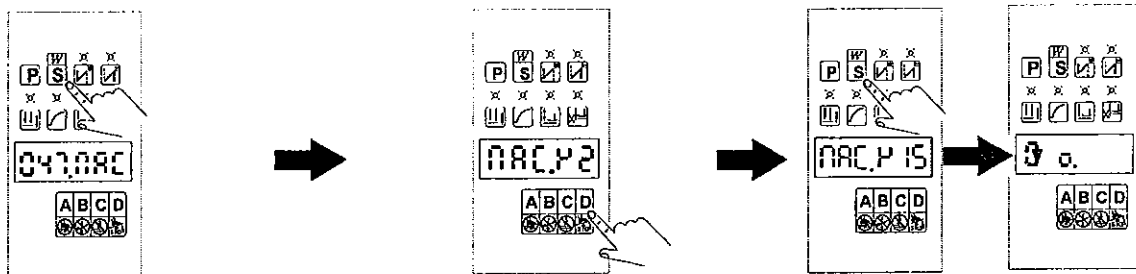

Code	Display	Applicable models
Y15	Y15	VT machines with UT-A34/ST2-A device

Table 2

Note : Normal mode is the mode in which the machine can be operated normally.

### ⚠ CAUTION

Do not set the codes other than Table 2. It can cause the breakdown and damage.

In case of simple setting, the sewing speed will be set to 4000rpm. Please change the sewing speed according to the machine model.

(Refer to "2.7.1.2 Setting sewing speed")

## 2. Installation

### 2.7.1.2 Setting sewing speed

Set an appropriate sewing speed according to the machine model.

(Example) Changing the speed from 4500rpm to 4000rpm.

1. Press key **P**, LED displays "001. H".

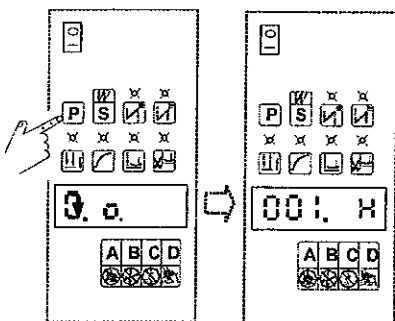

2. Press key **S**, LED displays "H. 4500".

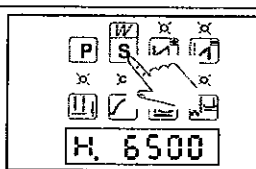

3. Press key **A B C D** to set the sewing speed.

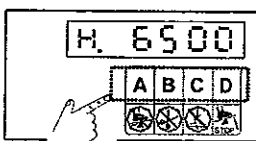

4. When displayed as "H. 4000", press key **S**.

5. It returns to "normal mode". Finished.

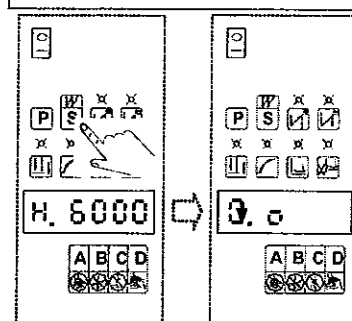

Perform the following steps in case the sewing speed can not be changed to the desired value.

1. Display the current speed.

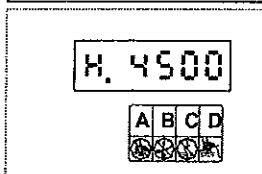

2. Press key **A** several times, lowest value "50" is displayed next to highest value "9xxx".

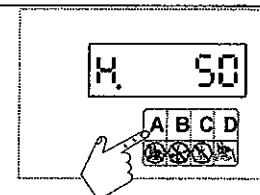
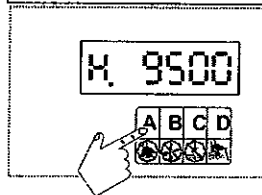

4. Press key **C**, the numerical value is turned over and be raised.

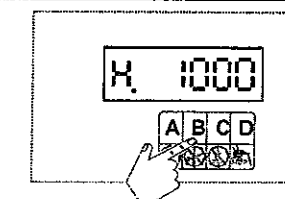
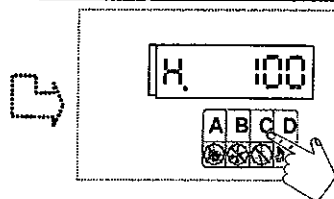

5. Press key **B**, the numerical value is turned over and be raised.

6. Set the numerical value with **A** key.

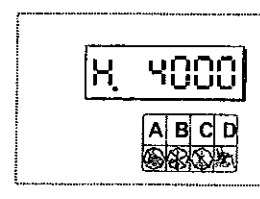

### ⚠ CAUTION

Do not input any sewing speed exceeding the speed limit. It can cause breakdown and damage to machine.

### 2.7.1.3 Disabling thread cutting function

Disabling or activating the thread cutting function can be set by **B** key.

If the mark 「□」 lights above the **B** key, it means that the thread cutting function has been disabled.

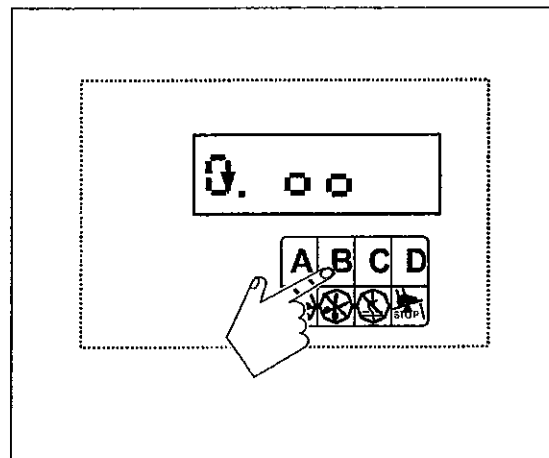

Fig. 14

## 2. Installation

### 2.7.2 UT-A34 (without Y motor)

#### 2.7.2.1 Simple setting

For main models, the setting for the motor can be changed in the following method.

1. Shift it to program mode [2].  
(Press [ $\downarrow$ ] + [C] + [D] keys at the same time.)

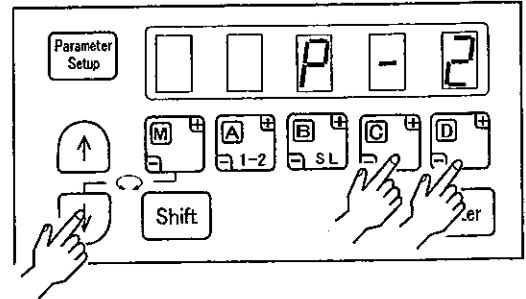

2. Shift to the program mode.

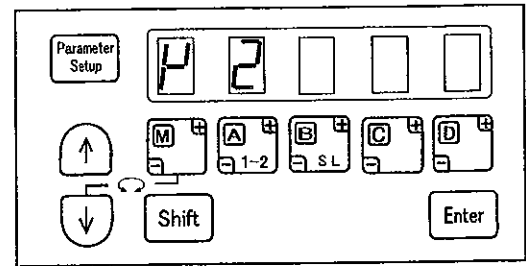

3. Press the [ $\downarrow$ ] key, functions will be shown as the following.

	Function	LED
UT-A34/ST2-A	Y15	P15

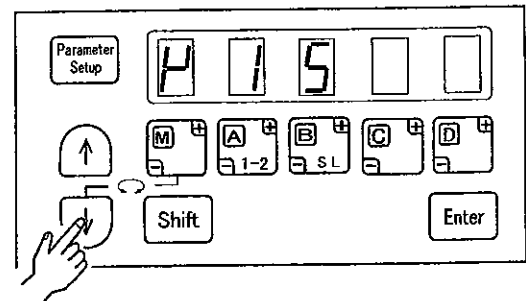

4. Keep pressing [D] key until the machine goes back to the normal mode.  
([Y15] will be blinking during setting. It means that the setting is changing.)

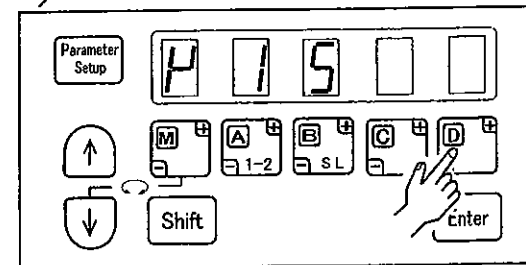

5. The normal mode will be displayed.  
(Setting finished)

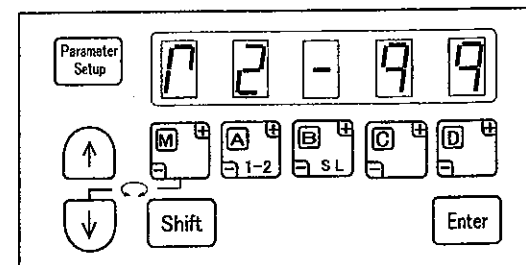



## 2.7.2.2 Setting sewing speed

Change the sewing speed according to the machine type.

(Example) Change the sewing speed from 4500 rpm to 4000 rpm.

1. Shift it to program mode [P].

(Press [↓] + [↑] keys at the same time)

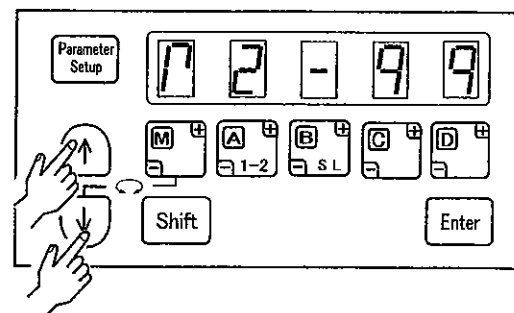

2. The program shifts to mode [P].

(The value has been shown is the setting value.)

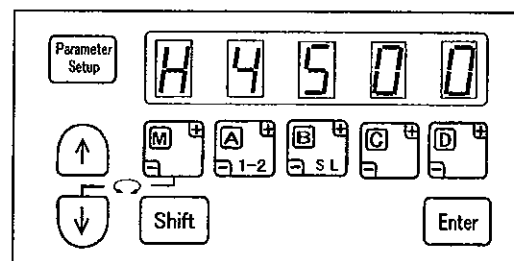

3. Press [A], [B], [C] and [D] keys to display [4 0 0 0].

The number value on each figure will be increased by pressing each key. "0" will be displayed after "9".

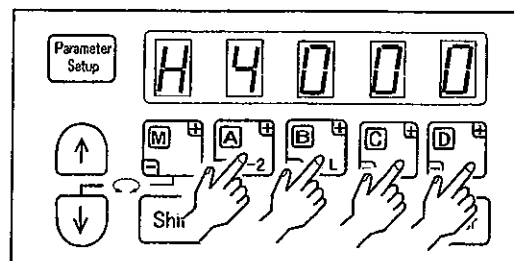

4. Press [↓] + [↑] keys at the same time, shift the machine to normal mode.

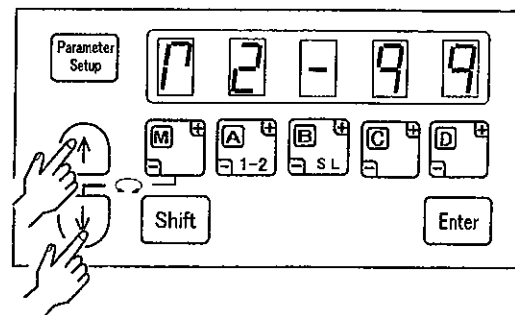

### ⚠ CAUTION

Do not input any sewing speed exceeding the speed limit. It can cause breakdown and damage to machine.

## 2. Installation

### 2.8 Adjusting rotation detector unit

#### 2.8.1 UT-A34/Y (with Y motor)

Check the needle stops between the highest point and 0.5 mm lower than the highest point.

#### 2.8.2 UT-A34 (without Y motor)

### ⚠ CAUTION

Unplug all the intermediate cables which are connected to the solenoid valves. If not, they may be scratched by moving parts and be damaged.

- (1) Install the rotation detector ① onto the synchronizer adapter ④ and tighten the screws ② slightly.
- (2) Set the synchronizer positioning pin ③ into the groove of the synchronizer ①.
- (3) Turn on the motor switch.
- (4) Toe down the pedal to sew two or three stitches.
- (5) Heel back the pedal. Then the needle stops at a certain position.
- (6) Loosen the screws ②, and turn the handwheel ⑤ clockwise. Set the mark ⑥ on the machine arm at "P" on the handwheel ⑤. At the same time, make sure the screws ② on the rotation direction have not slipped out of the positions.

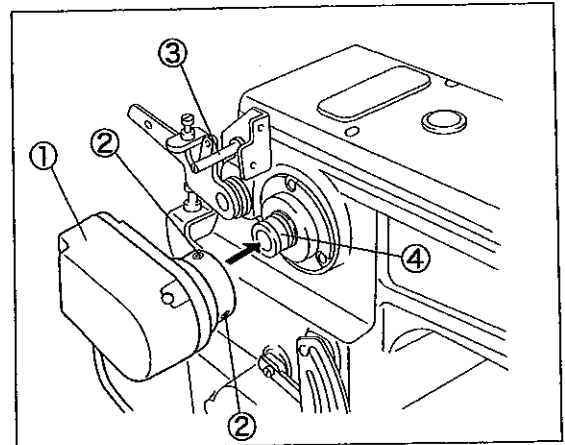

Fig. 15

### NOTES

1. At this moment, the needle bar is at the highest point.
2. Turn the pulley clockwise. The using range of this device is between where the needle bar is at the highest point to the position that 0.5 mm below its highest point.

- (7) Toe down the pedal to sew several stitches. Make sure that the needle bar stops at the position between the highest point and 0.5 mm below it.

After installing the synchronizer, refer to [2.6.4 Solenoid valve number and intermediate cable part number] and connect the intermediate cable to solenoid valves until they click.

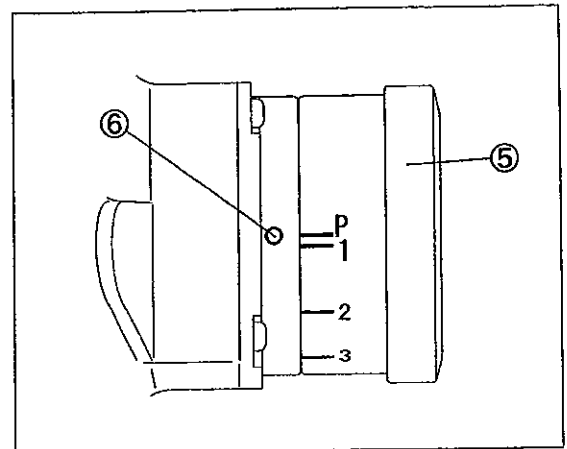

Fig. 16

# 3. Proper operation

## 3.1 Threading



### ⚠ CAUTION

Before threading, ALWAYS turn the motor switch OFF and check that the motor has already stopped. Improper threading can cause thread breakage, skip stitch, and uneven stitch.

Refer to Fig. 17 for threading.

### ⓘ Supplement

The tension release starts to work, and the thread can be pulled out easily, when the presser foot is raised up.

If it has already threaded, tie with new threads.

#### <A Needle thread>

Pull out the thread until it comes to the front of the needle. Then, cut off the knot before passing it through the needle eye.

#### <B Top cover thread>

Pull the thread until the knot comes out.

#### <C Looper thread>

Pull the thread until the knot comes out. Cut the tip with a pair of scissors.

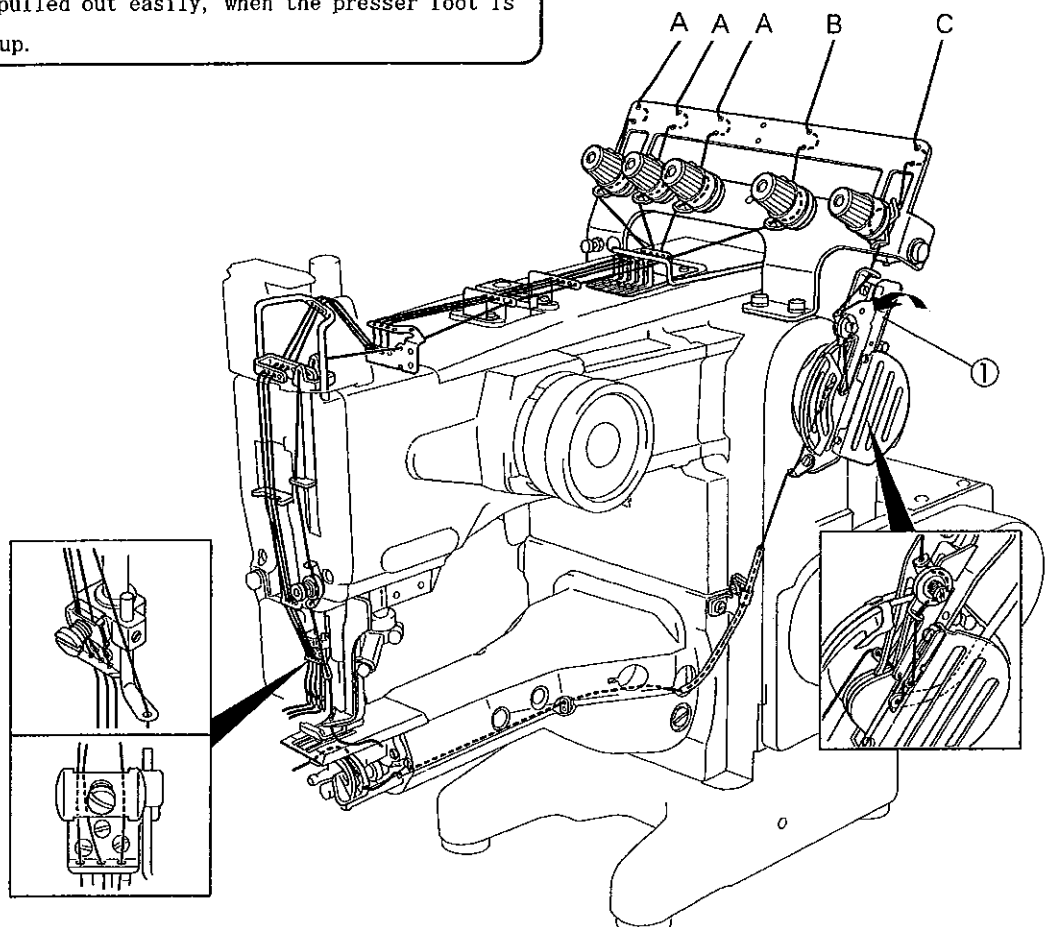

Fig. 17

### ⓘ Supplement

Looper thread can be threaded easily, if the supporting plate① is raised up. After threading, return it to its original position until you hear it clicks.

### 3. Proper operation

## 3.2 Stitch length adjustment



### WARNING

Turn off the power switch of the motor and check motor rotation has stopped before adjusting stitch length. Otherwise, you will be injured.

Stitch length can be adjusted infinitely from 1.2mm to 4.0mm.

Each graduation on the handwheel③ indicates the length (mm) of one stitch.

\*Actual stitch length may vary depending on the type and thickness of fabric, and the differential ratio.

### Changing stitch length

(1) Press the pushbutton① with your left hand until you feel the end of button contacts internal parts.

(2) Turn the handwheel③ clockwise with your right hand, while holding down the pushbutton①. At the point that the pushbutton① goes in, press it① again strongly.

- To make the stitch length larger, turn the pulley clockwise.
- To make the stitch length smaller, turn the pulley counterclockwise.

(3) With holding down the pushbutton①, set the mark ② on the arm at a scale on the hand wheel③.

(4) Once the marks have been aligned, release the pushbutton①.

### CAUTION

Check the pushbutton① has returned to its original position completely, and the handwheel③ turns smoothly.

Stitch length (mm)	Number of stitches per inch	Number of stitches per 30 mm
4.0	6	7.5
2.5	10	12
2.0	12.7	15
1.2	21	25

Table 3

◇Table 3 shows the number of stitches per inch and 30 mm.

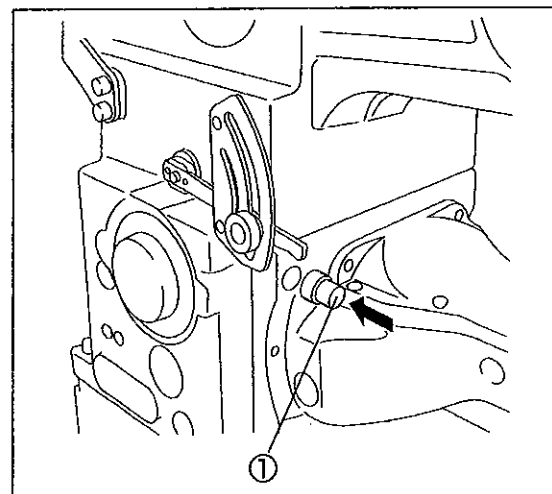

Fig. 18

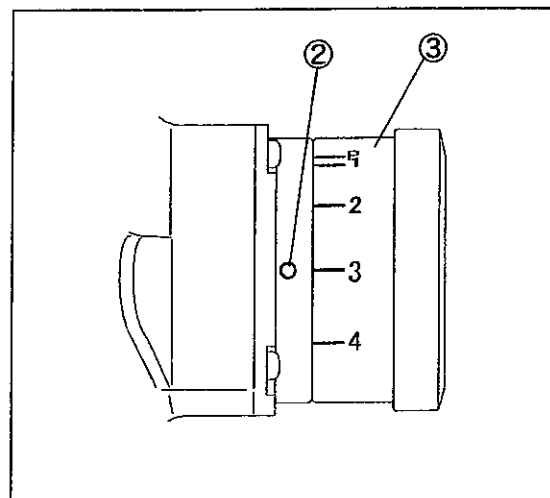

Fig. 19

### 3.3 Operating procedure



#### UT-A34/ST2-A/Y

The setting for motor can be selected from 1 position or 2 position. The following is the procedure under 1 position and 2 position.

- (1) Heel back the pedal to raise the presser foot.  
(Fig. 20 ③)
- (2) Place a fabric under the presser foot and toe down the pedal. (Fig. 20 ①)  
The machine starts sewing.
- (3) Release the pedal. (Fig. 20 ②)  
The needle stops at the highest point. (In case of 1 position.)  
The needle stops at the lowest point. (In case of 2 position.)
- (4) Heel back the pedal. (Fig. 20 ③)
  - The needle rises and stops at the highest point.  
(Only in case of 2 position.)
  - The trimming knife mechanism operates to cut the needle and the looper threads under the stitch plate. The looper thread is held by the thread clamp.
  - The ST2-A device cuts and holds the top cover thread. The presser foot rises.
- (5) Release the pedal. (Fig. 20 ②)  
The presser foot is lowered.

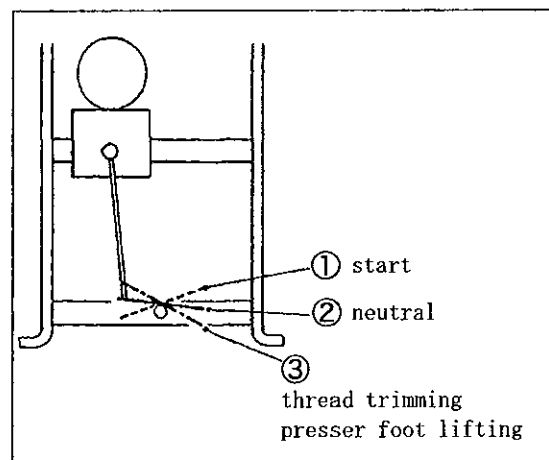

Fig. 20

#### Supplement

The presser foot can be raised and lowered by heeling back the pedal to the positions ② and ③, except for the pedal is toed down to the position ①.

#### CAUTION

Be sure to keep the height from the stitch plate to the bottom of presser foot under 5 mm, when the fabric is placed and the presser foot is lowered. If the knife of ST2-A touches the presser foot, the knife can be damaged.

## 3.4 Removing and reinstalling stitch plate

### Removing

1. Turn the hand pulley, and it make the needle the highest point.
2. Remove the presser foot.
3. Loosen the screw ①, and remove the stitch plate ②.

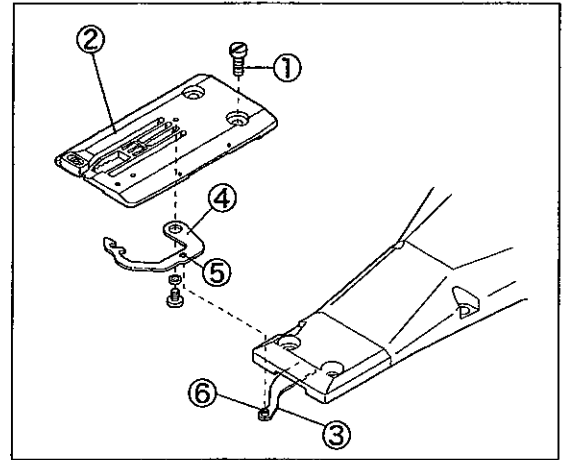

Fig. 21

### Reinstalling

1. Raise the needle to the highest point.
2. Check that driving rod ③ is returned.
3. Check that movable trimming knife ④ on the back of stitch plate is returned.
4. The hole ⑤ of the movable trimming knife is set in the pin ⑥ in the driving rod tip, and set the stitch plate ②.
5. Tighten the screw ① lightly.



## WARNING

Check the pin ⑥ is in the hole ⑤ of the movable trimming knife. If not, it may cause damage to machine and injury to person.

6. Check the needle and needle fall of the stitch plate, parallel the slot of stitch plate with the feed dog. Tighten the screw ① securely.
7. Install the presser foot.

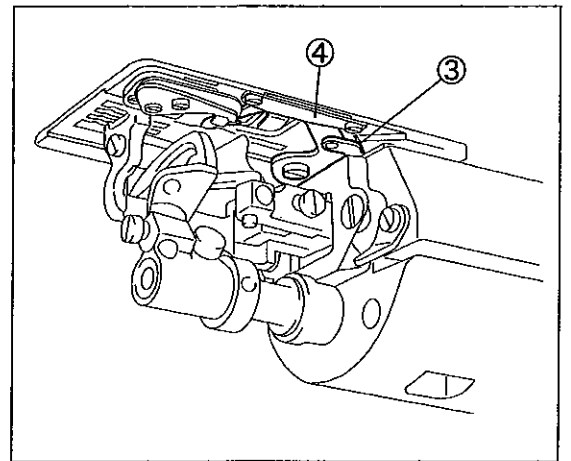

Fig. 22

**3.5 Regular maintenance (only for UT-A34/Y with Y motor)**

Remove the belt cover ① to clean around it once a month.

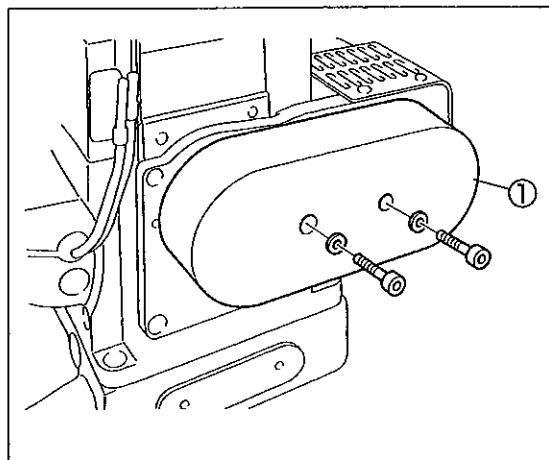

Fig. 23

**⚠ CAUTION**

Clogged dust between the timing pulleys ③④ and the timing belt ⑤ can cause the belt breakage.

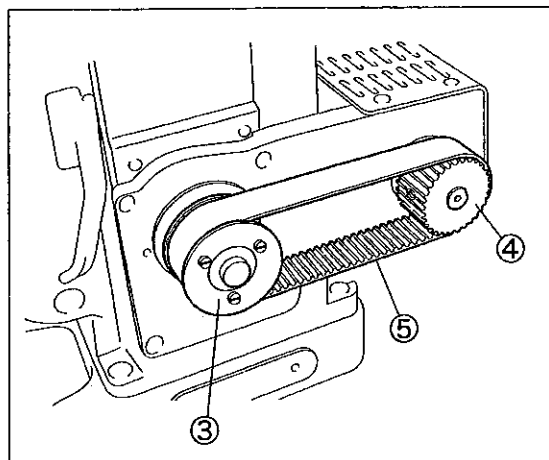

Fig. 24

# 4. Adjustment

## ⚠ WARNING

ALWAYS turn the motor switch OFF and check that the motor has already stopped.

### 4.1 Trimming knife mechanism

#### 4.1.1 Position of movable trimming knife

##### Coming out position of movable trimming knife

For the standard position of movable trimming knife①, align movable trimming knife① tip with the mark on the back of the stitch plate② when the air cylinder comes extreme out.

- (1) Turn the hand pulley, raise the needle to the highest point.
- (2) Remove the cylinder top cover.
- (3) Stop the air.
- (4) Pull out the air cylinder's rod⑥ fully.
- (5) Loosen the screw④ of the air cylinder collar③.
- (6) Make adjustment by loosening the nut⑤ and rotating the rod⑥.
- (7) Tighten the nut⑤.
- (8) Tighten the screw④ slightly, adjust the return position of the movable trimming knife.

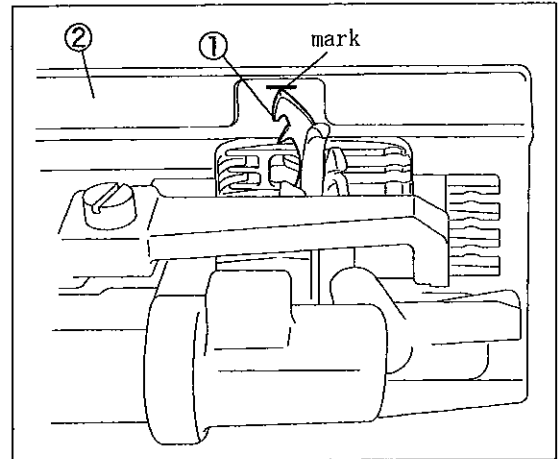

Fig. 25

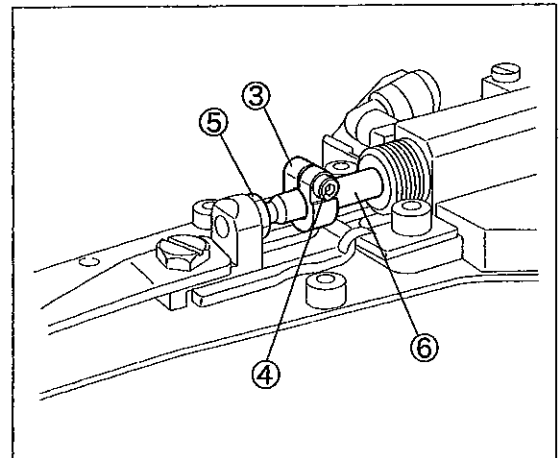

Fig. 26

## ⚠ CAUTION

Readjust both coming out position and return position after adjusting the position of the movable trimming knife.

Also, be sure to check the detection switch.



### Return position of movable trimming knife

When the movable trimming knife ① returns, make the edge A of the stitch plate overlap with the trimming knife ①. Make sure that the engagement between the trimming knife ① and tip ⑦ of the hook is 0.3-0.5mm.

- (1) Remove the cylinder top cover.
- (2) Loosen the screw ④ of the air cylinder collar ③.
- (3) Make the edge A of the stitch plate overlap with the trimming knife ①, when movable trimming knife ① returns.
- (4) Attach the collar ③ onto the air cylinder ⑨, and tighten the screw ④.
- (5) Install the cylinder top cover.

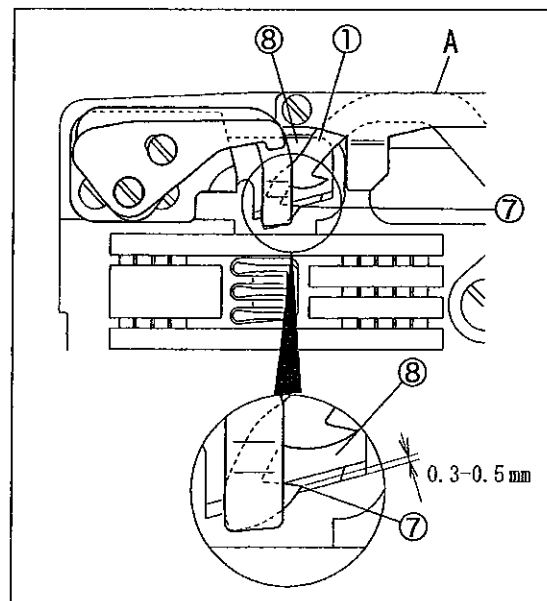

Fig. 27

### ⚠ CAUTION

Check the detection switch works good.

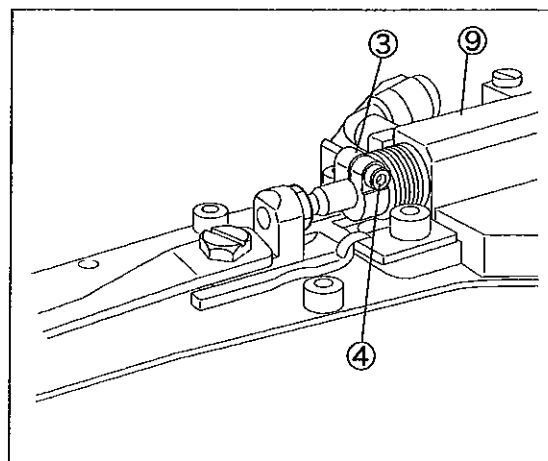

Fig. 28

## 4.Adjustment

### 4.1.2 Adjusting detector switch

The detector switch is equipped so that the machine does not work until the trimming knife returns to its original position.

- (1) Remove the top cover.
- (1) Turn the hand pulley to raise the needle to the highest point.
- (3) Check the air cylinder's rod ① is returned.
- (4) Turn on the motor switch.
- (5) Check the icon ② on the leftmost of the display ② rotates.
- (6) Check the icon ② rotates when the rod ① is pull out for 0.5 mm, and it stops when the rod ① is pull out for 1 mm.
- (7) To adjust the position of detector switch ③, loosen the screw ④ and move it back and forth.
- (8) Reinstall the cylinder top cover.

#### **WARNING**

Never touch the motor pedal.  
Be sure to turn off the motor switch after adjustment or check.

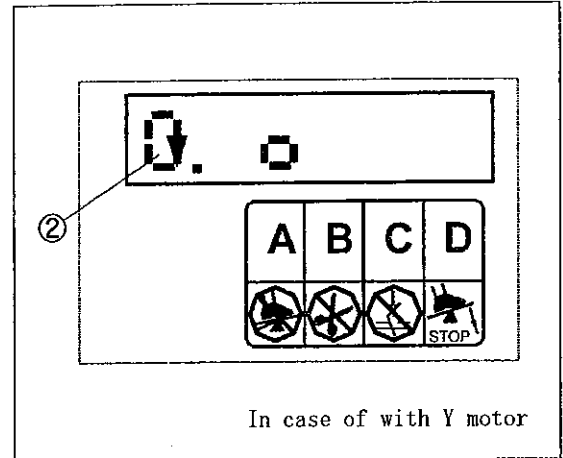

Fig. 29

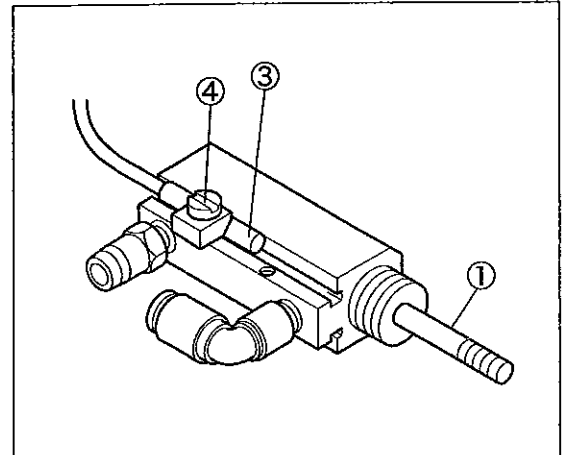

Fig. 30

### 4.1.3 Thread clamp

For the standard position of the thread clamp①, make adjustment on the direction "X" to align the thread clamp① with the end of hook③ on movable trimming knife②, when the end of the hook③ on movable trimming② knife is engaged with the fixed trimming knife④. (Fig. 31)

Make adjustment on the direction "Y" to match the tip of the movable trimming knife② with the tip of the thread clamp① and tighten the screw⑤, after the movable knife returned. (Fig. 32)

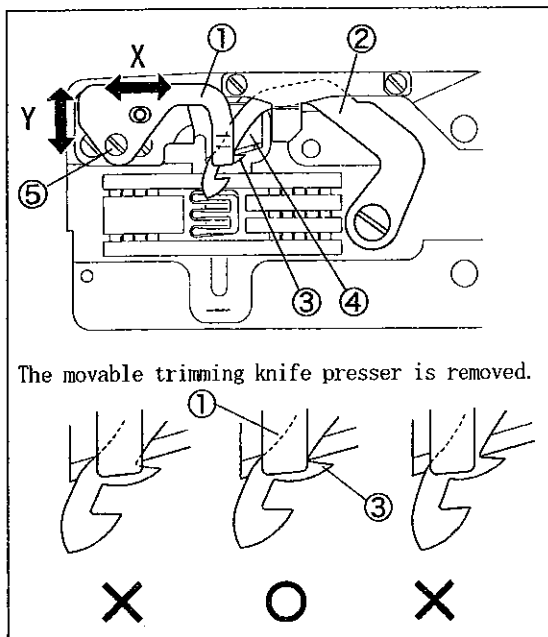

Fig.31

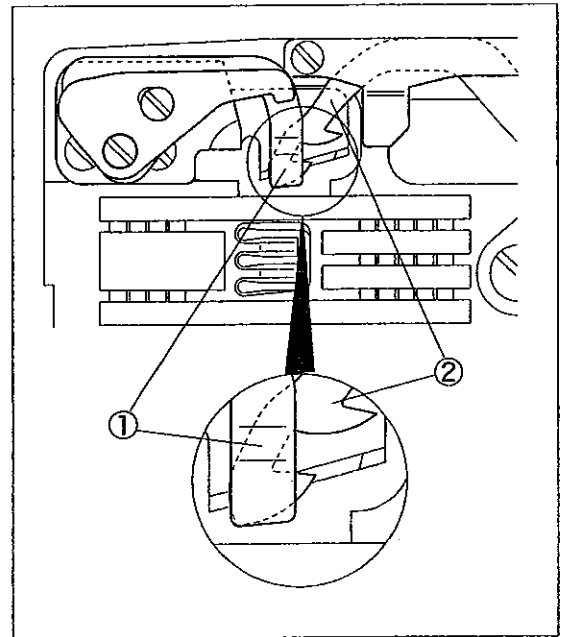

Fig.32

### 4.1.4 Movable trimming knife presser

Move the movable trimming knife presser① in the direction of "Y", and tighten the screw③ at the end of the slot.

Tighten the screw② securely after adjustment.

- To increase the pressure, move it④ in the direction of "X".
- To decrease the pressure, move it④ in the direction of "Y".

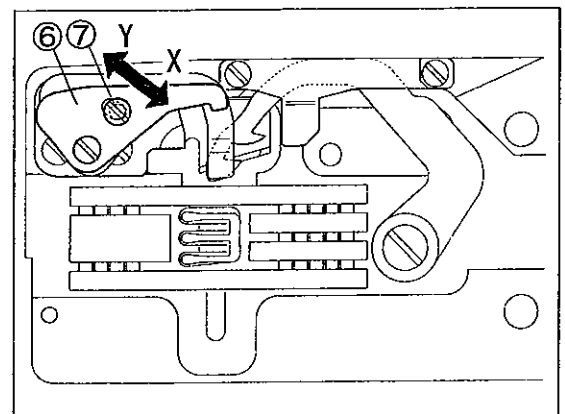

Fig.33

### 4.1.5 Relation between movable trimming knife, needle thread, and looper thread

After all of the adjustment, thread correctly and check the following items before sewing.

- The movable trimming knife① should pass in the loops③ and ④ and the hook② should pass the front of the looper thread.
- When the movable trimming knife① returns, the needle and the looper threads are hooked by the hooks ② and ⑤ respectively, and then they will be cut by the upper knife.
- If the device does not work good, even though the above-mentioned adjustment has been performed, check the following items and make adjustment.
  - (1) If the needle and needle fall of the stitch plate are in proper positions, and if the slot of stitch plate is parallel with the feed dog.
  - (2) If the needle stops at the highest point.
  - (3) If the timing and the amount of the tension releaser is appropriate.  
(Refer to "4.2 Tension releaser mechanism")
  - (4) Coming out position of the movable trimming knife .  
(Refer to " 4.1.1 Position of movable trimming knife")
  - (5) Return position of the movable trimming knife.  
(Refer to"4.1.1 Position of movable trimming knife")

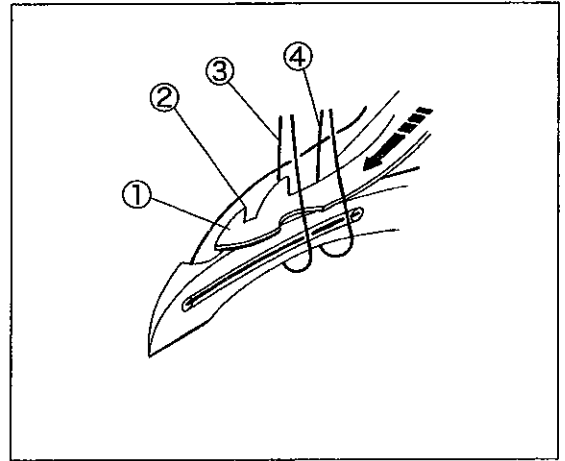

Fig. 34

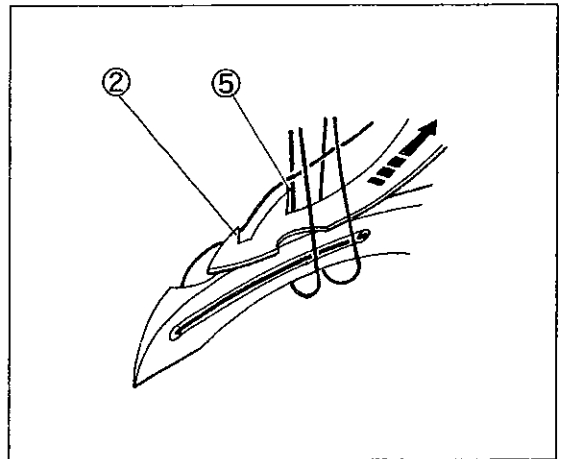

Fig. 35

## 4.2 Tension release mechanism

### 4.2.1 Tension release of needle thread

#### Needle thread pull-off (rear)

Loosen the screw ③④ to adjust the distance between needle thread pull-off(rear) ① and upper surface of thread pull-off eyelet bracket ② to 5 mm when the needle thread is loosened.

#### Amount of needle thread remainder

Align the front end of thread pull-off eyelet ⑤ with the tip of thread pull-off eyelet bracket ② as standard.

- To decrease the needle thread remainder length, move it ⑤ in the direction "S".
- To increase the needle thread remainder length, move it ⑤ in the direction "L".

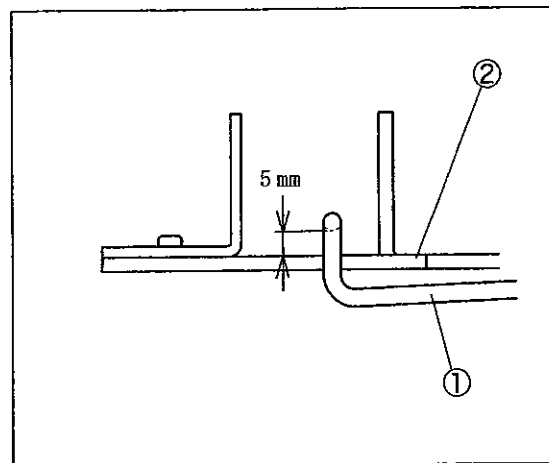

Fig. 36

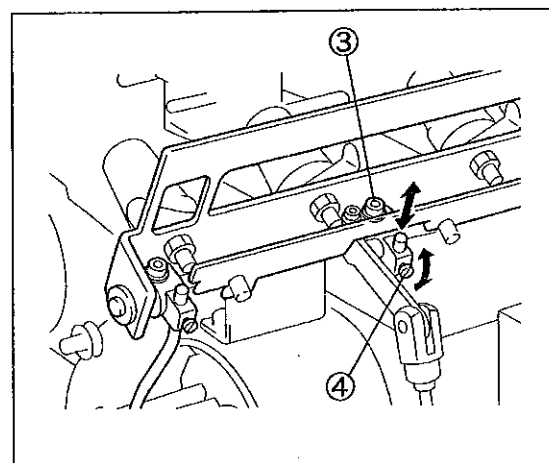

Fig. 37

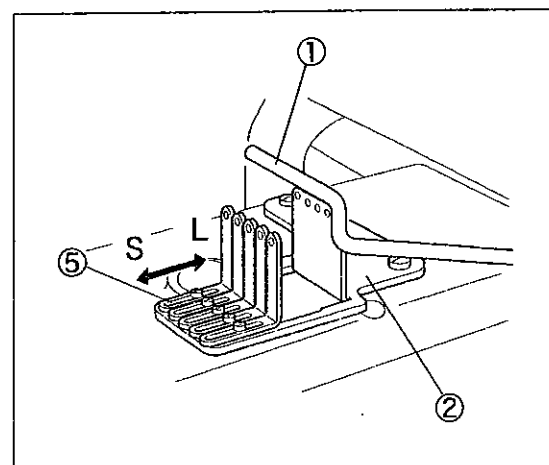

Fig. 38

### 4.2.2 Tension release of looper thread

Align the hole of looper thread pull-off eyelet ① with the hole of thread take-up eyelet ②.

Align the looper thread pull-off ③ with the center of cam ④ in the direction "X".

- To increase the thread remainder length, move it ③ in the direction "L".
- To decrease the thread remainder length, move it ③ in the direction "S".

In the direction "Y", the looper thread pull-off ③ is 2.5 mm from supporting plate to the center of it's eye. Loosen the screw ⑤⑥ to adjust it.

#### NOTE

1. Be sure to adjust the looper thread pull-off eyelet ①, after making adjustment of thread take-up eyelet ②.
2. Be sure to make adjustment on the direction "Y", after making adjustment on the direction "X".

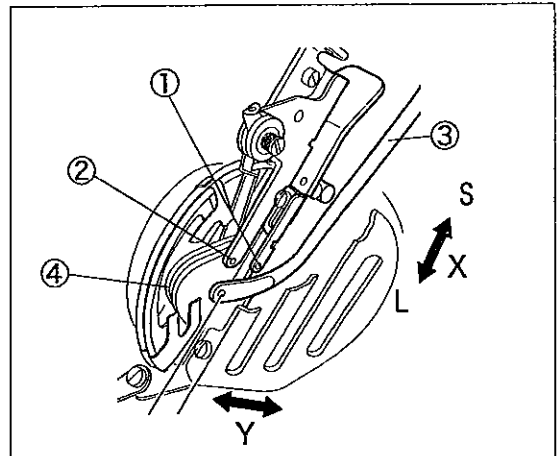

Fig. 39

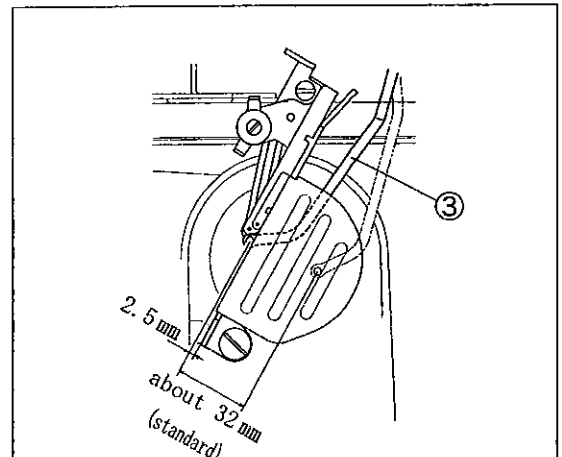

Fig. 40

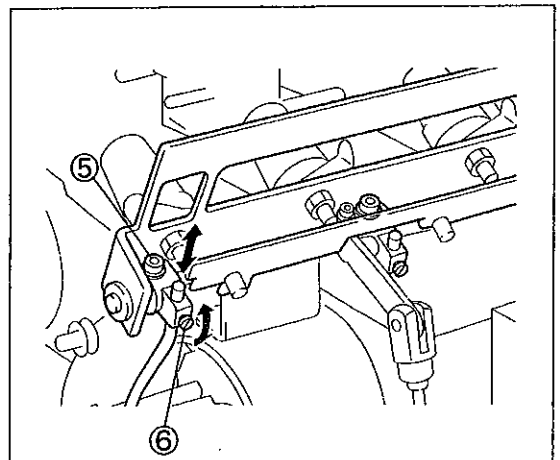

Fig. 41

**⚠ WARNING**

ALWAYS turn the motor switch OFF and check that the motor has been already stopped.

**4.3 Presser foot lifter mechanism**

- (1) Loosen the lock nut ①.
- (2) Turn the cylinder rod chip ③ to raise the presser foot by 8 mm when the cylinder rod ② is lower (when the cylinder operates).
- (3) Tighten the lock nut ① securely.

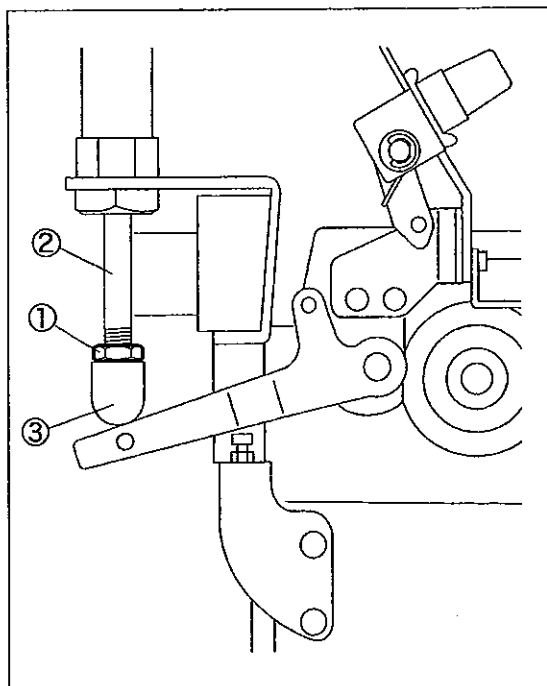

Fig. 42

## 4.Adjustment

### WARNING

ALWAYS turn the motor switch OFF and check that the motor has been already stopped.

## 4.4 ST2-A device

### 4.4.1 Position of movable trimming knife

- (1) Set the mark ② on the machine arm at the scale P on the handwheel ① (the needle is at the highest point).
- (2) Set the movable trimming knife ③ to the lowest point by inserting a pair of tweezers into the hole ④.

### CAUTION

Never let the movable trimming knife ③ touch the presser foot, the left needle ⑤, and the spreader ⑥.

If touches, loosen the screws ⑦ and ⑧ to make adjustment.

- (3) Loosen the screw ⑩. Make the clearance between the top of the stitch plate and the movable trimming knife tip ⑨ to 6.5 - 7.0 mm when the movable trimming knife ③ is at the lowest point.

### NOTE

After adjusting above, the movable trimming knife ③ should be crossed over the top cover thread.

- (4) After that, tighten the screws ⑦, ⑧, and ⑩ securely.
- (5) Check the position of the movable trimming knife with moving it up or down.

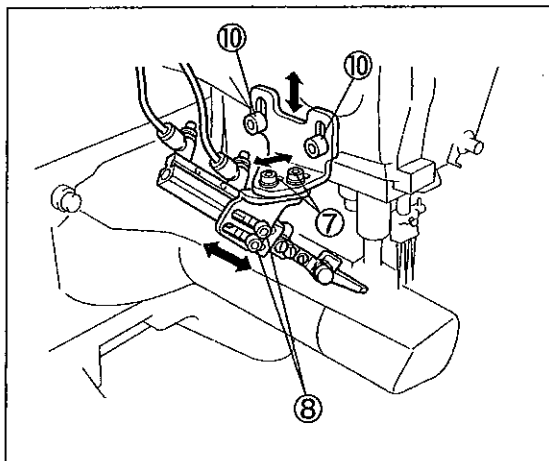

Fig. 45

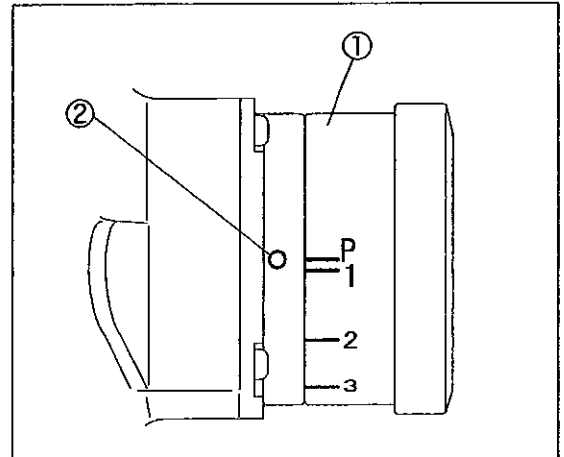

Fig. 43

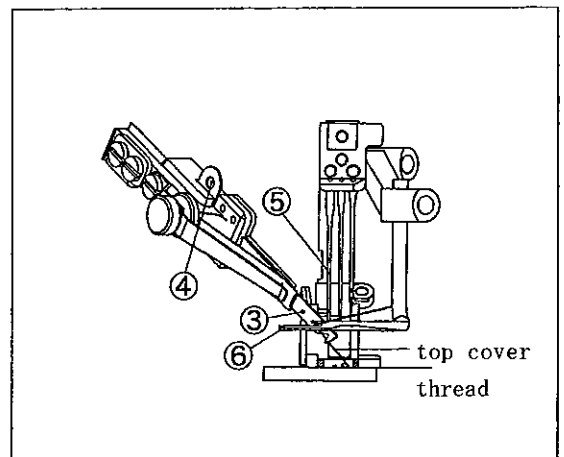

Fig. 44

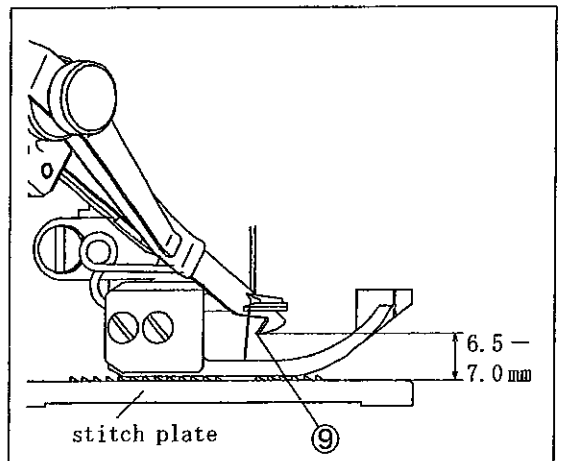

Fig. 46



**NOTE**

To adjust the speed of the movable trimming knife, loosen the nuts ① and turn the adjusting screws ② on the speed controllers of the air cylinder.

- To speed down, turn them clockwise.
- To speed up, turn them counterclockwise.

The presser foot starts rising immediately after cutting the top cover thread with the movable trimming knife. Adjust the speed so that the movable trimming knife does not touch the presser foot.

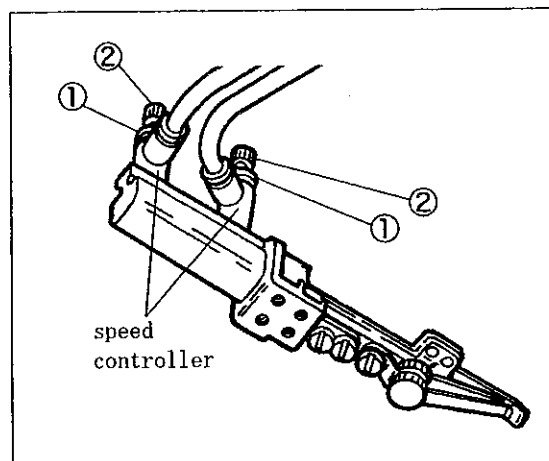

Fig. 47

**4.4.2 Engagement between movable and fixed trimming knives****⚠ WARNING**

**ALWAYS** turn the motor switch OFF and check that the motor has been already stopped.

The engagement between the movable trimming knife ③ and the fixed trimming knife ④ has been adjusted as shown in Fig. 48.

Normally adjustment above is unnecessary.

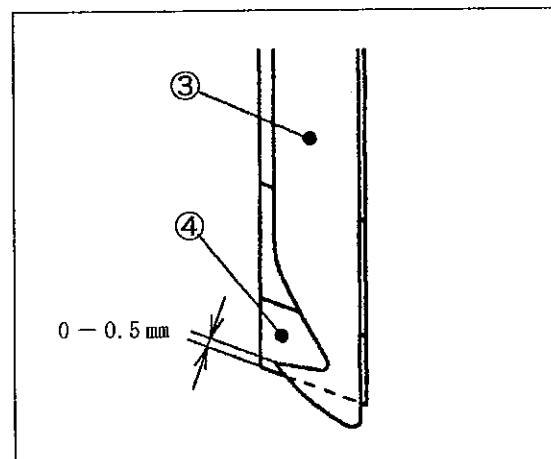

Fig. 48

**① Supplement**

The stroke of the movable trimming knife is the same as that of the air cylinder.

## 4.Adjustment

### WARNING

ALWAYS turn the motor switch OFF and check that the motor has been already stopped.

#### 4.4.3 Pressure of thread clamp spring

Keep the pressure as low as possible to hold the threads.

- (1) Loosen the nut ③.
  - (2) Adjust the pressure with the adjusting screw ④ so that the thread clamp spring ② and the movable trimming knife ① can hold the threads after they are cut by the knife.
- To increase the pressure, turn the adjusting screw ④ clockwise.

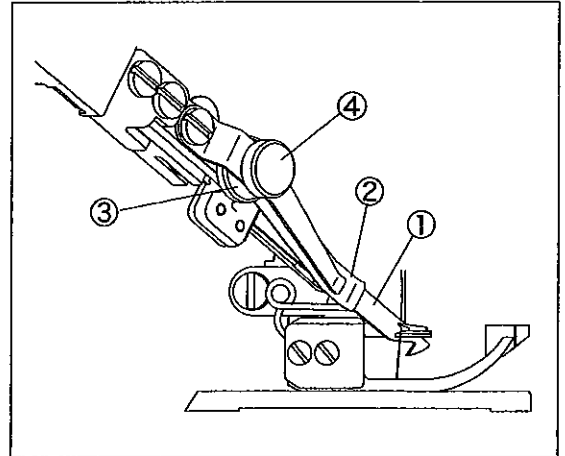

Fig. 49

#### 4.4.4 Adjusting thread pull-off hook unit

- To increase the thread remainder length, move the thread take-up ③ in the direction "L".
- To decrease the thread remainder length, move the thread take-up ③ in the direction "S".

### NOTE

The thread remainder length should be kept as much as possible. If not, the top cover thread cannot be held after cutting.

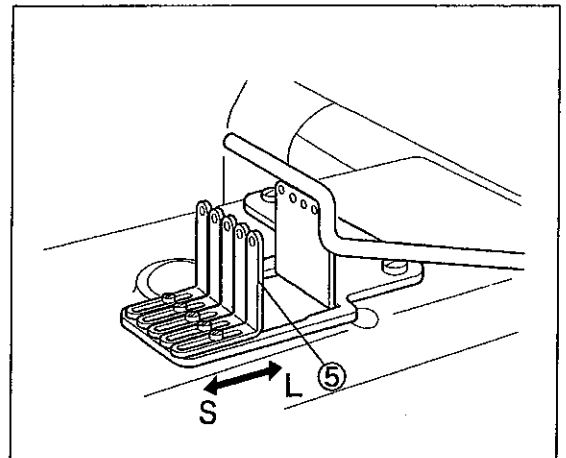

Fig. 50

**⚠ WARNING**

ALWAYS turn the motor switch OFF and check that the

**4.5 Changing timing belt (UT-A34/Y with Y motor)****Removing**

1. Loosen the screws ① to remove the belt cover ②. (Fig. 51)
2. Loosen the screws ④ of pulley(front) ⑦ to remove the flange ③. (Fig. 52)
3. Remove the timing belt ⑤ while turning the pulley ⑦ (Fig. 53)

**Reinstalling**

1. Hang the timing belt ⑤ on the pulley(rear) ⑥, then the other end on the pulley(front) ⑦.
2. Turn the handwheel and press the timing belt ⑤ until the timing belt ⑤ comes to the center of machine pulley(front) ⑦. Make sure that the timing belt ⑤ is parallel with the motor bracket ⑧.
3. Install the flange ③ onto the machine pulley(front) ⑦. (Fig. 52)
4. Reinstall the belt cover ①. (Fig. 51)

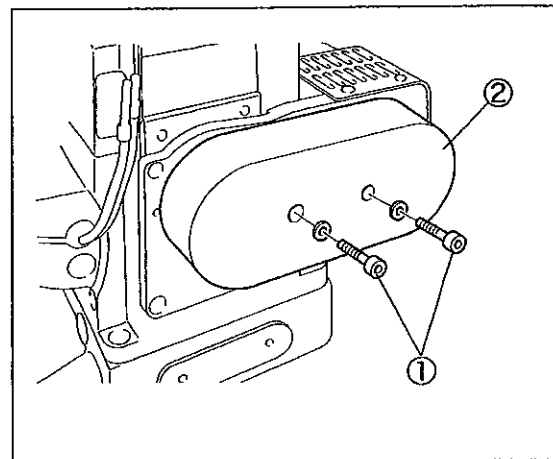

Fig. 51

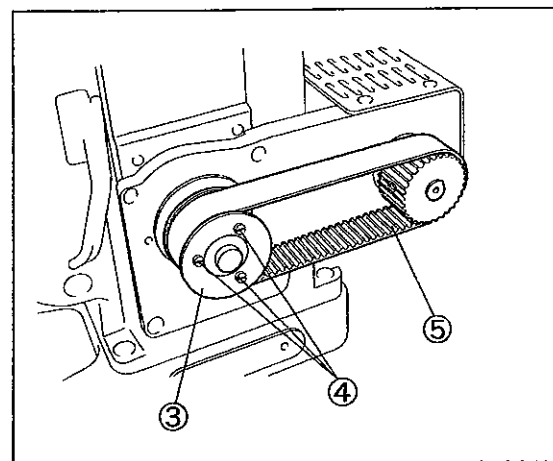

Fig. 52

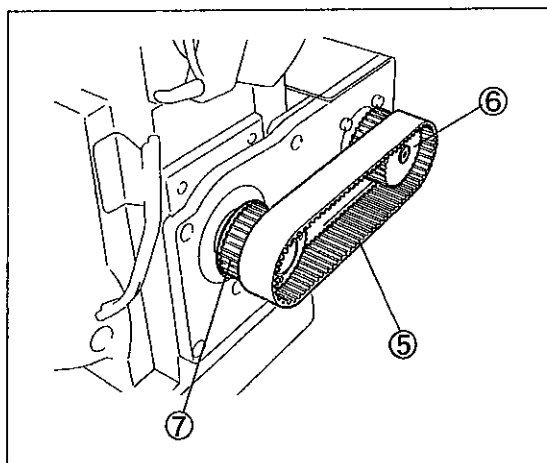

Fig. 53

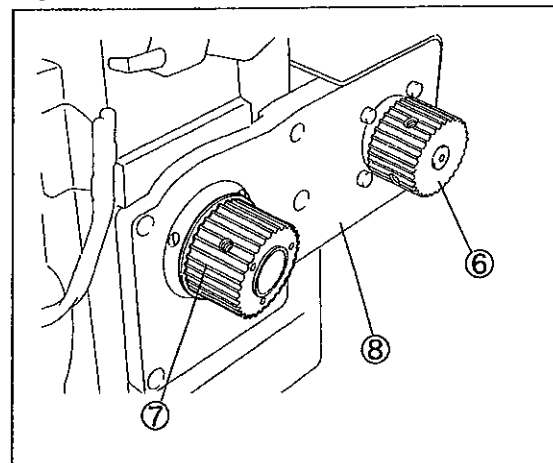

Fig. 54

***Yamato***

ヤマトマシン製造株式会社

***YAMATO SEWING MACHINE MFG. CO., LTD.***

4-4-12, NISHITENMA, KITA-KU, OSAKA, JAPAN  
TEL : 81-6-6364-1321 FAX : 81-6-6364-1307

〒530-0047 大阪市北区西天満4丁目4番12号  
TEL(06)6364-1321(代) FAX(06)6365-5176