

INSTRUCTIONS

VG3721

HIGH SPEED CYLINDER BED
CHAINSTITCH MACHINE
WITH LEFT HAND KNIFE
TRIMMING MECHANISM

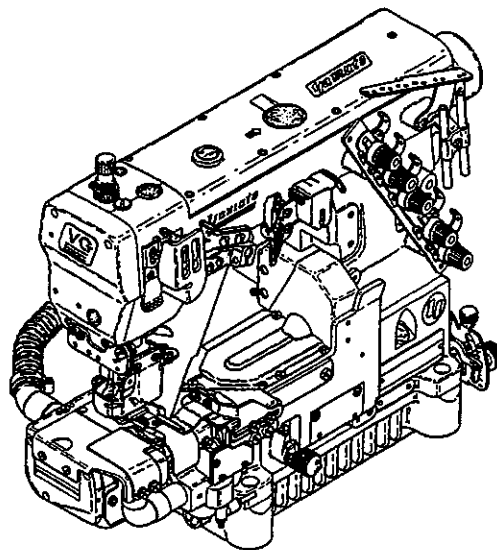







SAVE ALL INSTRUCTION MANUALS.

READ and UNDERSTAND THOROUGHLY to OPERATE for SAFE USE.

 **YAMATO SEWING MACHINE MFG. CO., LTD.**

Contents

Safety instructions	i-iv
1. Names of each part	1
2. Installation	2
2-1 Table cutting diagram	2
2-1-1 Table top type (Type A: standard)	2
2-1-2 Table top type (Type B)	3
2-2 Table top installation	4
2-3 Motor and belt	5
2-4 Engaging belt	6
2-5 Installing belt cover	6
2-6 Installing eye guard and finger guard	7
3. Sewing speed and rotating direction of pulley	8
4. Lubricating oil	9
4-1 Lubricating oil to be used	9
4-2 Supplying oil	9
4-3 Replacing oil	10
4-4 Checking and replacing oil filter	10
5. Proper operation	11
5-1 Needle to be used	11
 5-2 Installing needle	11
 5-3 Threading	12
 5-4 Adjusting thread tension	13
 5-5 Presser foot pressure	13
5-6 Adjusting the position of presser foot	13
 5-7 Adjusting stitch length	14
 5-8 Adjusting movement of differential feed dog (differential feed)	15
5-9 Setting differential ratio to 1:1.4 - 1:1.8	15
5-10 Setting differential ratio to 1:0.6 - 1:1.1	16
5-11 SP device and HR device	17
 5-12 Cleaning the machine	17
6. Adjustment of sewing machine	18
6-1 Position of needle thread eyelet	18
6-2 Position of needle thread guide	18
6-3 Position of thread take-up eyelet	19
6-4 Adjusting relation between needle and spreader	20
6-4-1 Adjusting spreader	20
6-4-2 Adjusting top cover thread guide	20
6-4-3 Adjusting top cover thread eyelet	21

Contents

6-5	Adjusting top cover thread eyelet(upper)	21
6-6	Distance between needle and looper	22
6-7	Using timing gauge	23
6-8	Adjusting needle height	23
6-9	Longitudinal position of needle and looper	24
6-10	Adjusting needle and needle guard(rear)	25
6-11	Adjusting needle and needle guard(front)	26
6-12	Height of feed dog	28
6-13	Adjusting presser foot lift	28
6-14	Adjusting feed of puller (with puller mechanism)	29
 6-15	Pressure of upper feed roller (with puller mechanism)	29
6-16	Adjustment of hemming folder(left)	30
6-17	Adjustment of trimming width by hemming folder spacer	30
6-18	Adjustment of hemming folder(right)	31
6-19	Adjustment of fabric guide(right)	31
6-20	Exchanging of fabric presser	31
7.	Adjustment of knife system	32
7-1	Installing accessories	32
7-2	Adjustment of suction pipe(front)	33
7-3	Adjustment of suction pipe cover	33
7-4	Trimming width(Cutting position of fabric)	34
7-5	How to remove and install the lower knife	35
7-6	How to remove and install the upper knife	36-37
7-7	Adjustment of upper knife stroke	38-39
7-8	Sharpening of knives	39
7-9	How to cancel(stop the movement of) left hand knife	40
7-10	How to call off the cancellation of left hand knife	41-42
8.	Specifications	43

This instruction manual is made mainly for technicians, however, the  marks are attached to the section titles which operator should read so as to operate the machines properly.



Safety Instructions



1. To ensure safe use

Always observe the following instructions to ensure the safe use of the industrial sewing machines and devices.

1-1 Application and purpose

The sewing machine is designed to improve productivity in the sewing industry and must not be used for other applications and purposes. Do not use this sewing machine until it can be confirmed that safety measures for the drive units have been taken.

1-2 Before use

Read all instruction manuals thoroughly before starting the use of this machine and follow them. Also, read the instruction manual for the installed drive unit.

1-3 Working environment

DO NOT WORK IN THE FOLLOWING ENVIRONMENTS:

- Place where atmosphere temperature and humidity give a bad influence the performance of sewing machines.
- Outdoors and place where the sewing machines are exposed to sunlight directly.
- Atmosphere containing dust, corrosive gases or flammable gases.
- Place where voltage fluctuation exceeds $\pm 10\%$ of the rated voltage.
- Place where power capacity necessary for the used motor specifications can not be secured.
- Place where strong electric or magnetic fields are generated such as near large-output high frequency transmitters or high frequency welding machines.

1-4 Unpacking and transportation

- (1) Unpack from the top.
- (2) Never hold the parts near the needle or threading parts when removing the sewing machine head from the buffer of box.
- (3) When carrying the sewing machine head, have an assistant.
- (4) Pay attention not to get excessive impact or shock when moving the sewing machine head with a pushcart.

2. Installation and preparation

2-1 Instruction and training

Operators and workers who supervise, repair or maintain the machine head and machine unit are required to have the adequate knowledge and operation skills to do the job safely. In order to establish such necessary conditions, it needs for the employer to plan and enforce the safety education and training to those workers.

2-2 Sewing table and motor

- (1) Prepare a machine table that has enough strength to withstand the weight of the sewing head and any reaction while operating.
- (2) Maintain a comfortable working environment with considering the lighting and the arrangement of sewing machine so that the operators can work smoothly.
- (3) When installing the control box and the related parts on the sewing machine, take care about the posture of the worker.
- (4) Install the drive unit correctly according to the instruction manual.



Safety Instructions



2-3 Wiring

- (1) Never connect the plug for power supply until assembly is finished.
- (2) Fix the connectors securely to the sewing machine head, motor, and electric apparatus.
- (3) Do not apply excessive force to the connection cords.
- (4) Connect the cords away from the driving parts.
- (5) Place the ground wire securely to the designated position on the machine head.

2-4 Before operation

- (1) Take care not to attach lubricant, silicone oil, and grease on the eyes or skin. Keep them away from children.
- (2) Be sure to fill or drop lubrication oil before operating the sewing machine. Use the Yamato SF oil as specified.
- (3) Never put your hand under the needle or near the moving parts of the machine when turning on power supply switch.
- (4) When operating a new sewing machine, make sure the rotating direction of pulley agrees with the rotating-direction mark.

2-5 During operation

- (1) Be sure to operate the sewing machine with the safeguards such as belt cover, finger guard, eye guard.
- (2) Never place the finger, hair or objects under the needle or close to the moving parts while operating the sewing machine.
- (3) Be sure to turn off the power supply switch when threading or replacing the needles.
- (4) Never place your hands close to the knives when operating the sewing machine with the trimming devices.

- (5) Be sure to turn off the power supply switch when terminating the sewing work or leaving the sewing machine.
- (6) If the sewing machine malfunctions, abnormal sound or smell something unusual while operating, be sure to turn off the power supply switch.

2-6 Removal

- (1) Turn off the power supply switch if removed or replaced any parts or during adjustment of sewing machine.
- (2) Do not pull the cord when removing the plug. Be sure to hold the plug itself.
- (3) A high voltage is applied inside the control box. Turn off the power supply switch and wait more than 5 minutes before opening the cover.

3. Maintenance, inspection, and repair

- (1) Follow the instruction manuals for maintenance, inspection, and repair.
- (2) Entrust the maintenance, inspection, and repair to specially trained personnel.
- (3) Be sure to turn off the power supply switch and make sure the sewing machine and motor completely stop before the maintenance, inspection, and repair. (If using a clutch motor, take care that the motor keeps turning for a while even after turning off the power supply switch.)
- (4) Do not modify the sewing machine by the customer's judgement.
- (5) Be sure to use original replacement parts for repairs or maintenance.



Safety Instructions



4. Caution signs and alert pictorial markings

This instruction manual contains the following caution signs and alert pictorial markings to prevent you from injuring yourself or the sewing machine from being damaged. Please follow the instructions.

4-1 Meanings of caution signs

WARNING indicates a potentially hazardous situations which, if not heeded, could result in death or serious injury to you and others.

CAUTION indicates hazardous situations which, if not heeded, may result in minor or moderate injury to you and others, or may result in machine damage.

NOTE is used to emphasize essential information.

4-2 Alert pictorial markings



This mark indicates the warning which, if not heeded, could result in death or serious injury.



This mark indicates the caution for high temperature.



This mark indicates the caution which, if not heeded, may result in minor or moderate injury or machine damage and the note to emphasize essential information.



This mark indicates the warning of electric shock by high voltage.



This mark indicates the caution which, if not grounded, the machine or device could malfunction and could result in personal injury.

5. Warning labels on sewing machines



This label indicates that removal of the safeguards and works except for sewing performance while the power supply switch is on are prohibited. (For details, see the next page.)



High-voltage applies in the control box. This label indicates that electric shock may be caused.



This label is affixed on the safeguards. Considering the operation, it is not affixed on the finger guard and eye guard. Be sure to operate with the finger guard and eye guard in position.



Stepping motor and solenoid may overheat if used continuously. To prevent a burn, take care not to touch.



If not connected earth line, static electricity may be generated and inflict injury on person. In addition, the malfunction of electric system may cause injury to person.



Check the rotating direction of machine pulley agrees with 'ROTATING-DIRECTION SYMBOL'.



Safety Instructions

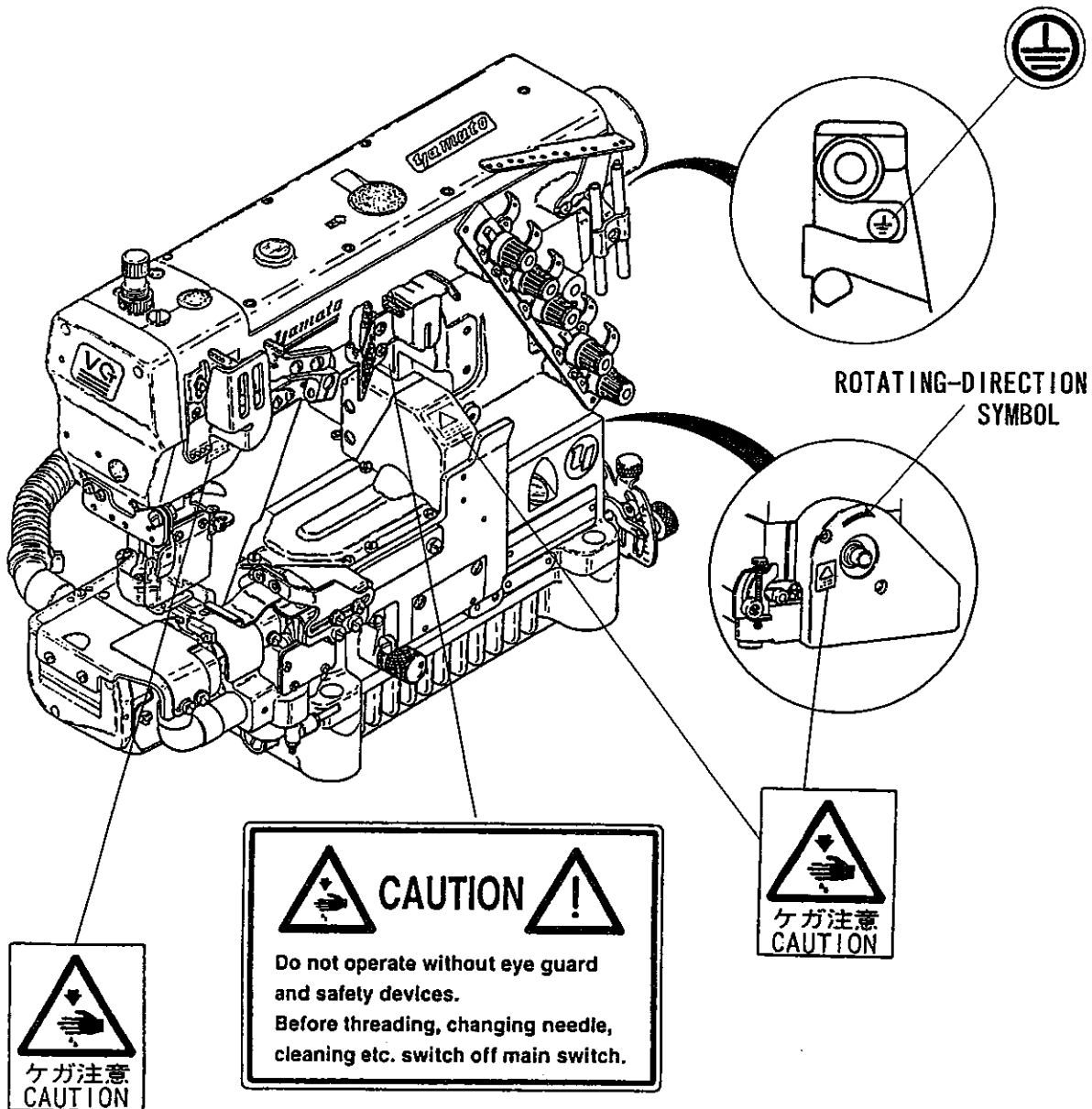

1. Names of each part

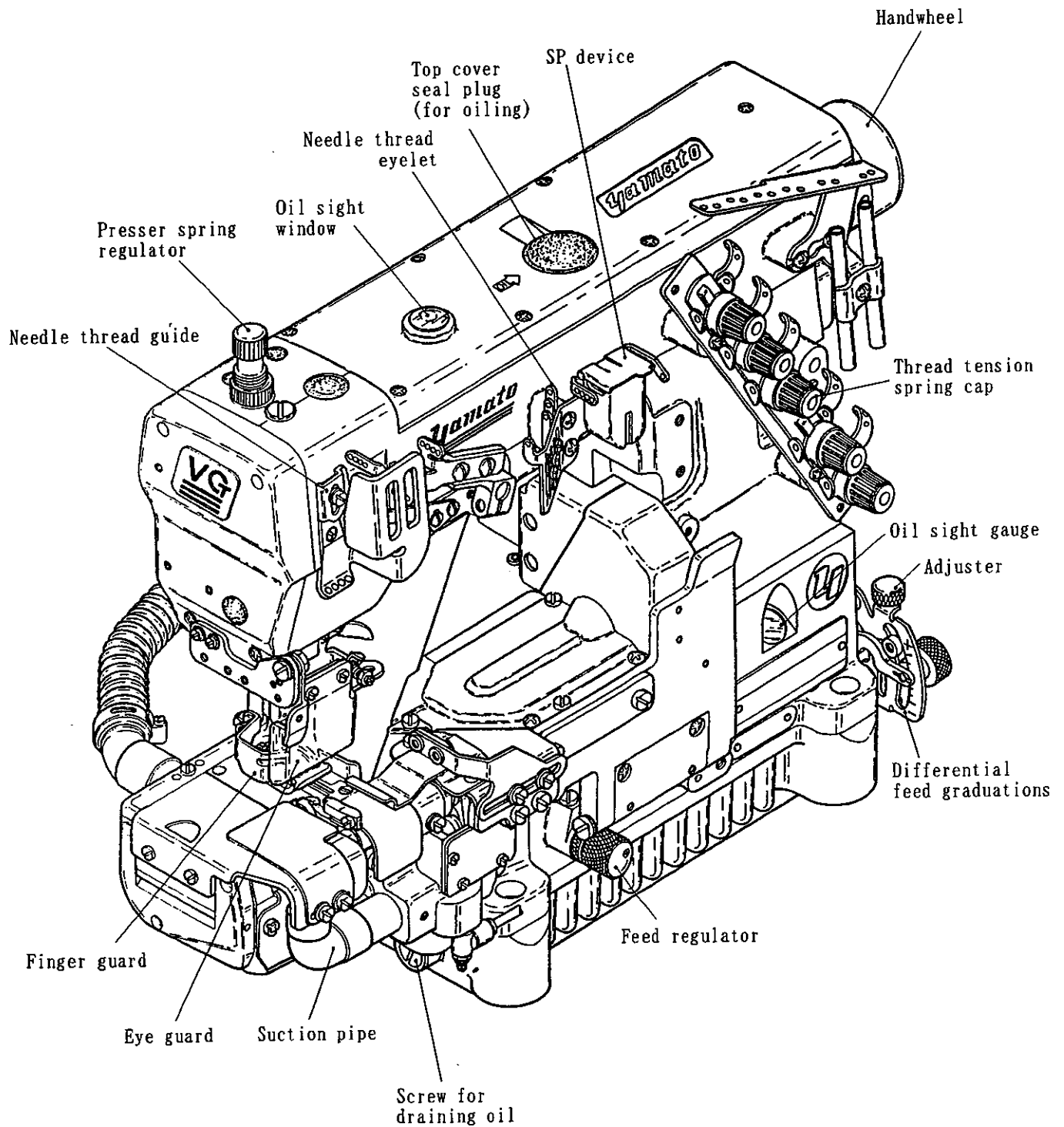

2. Installation

2-1-2 Table top type (Type B)

A	B	C	D
57	159	66	33

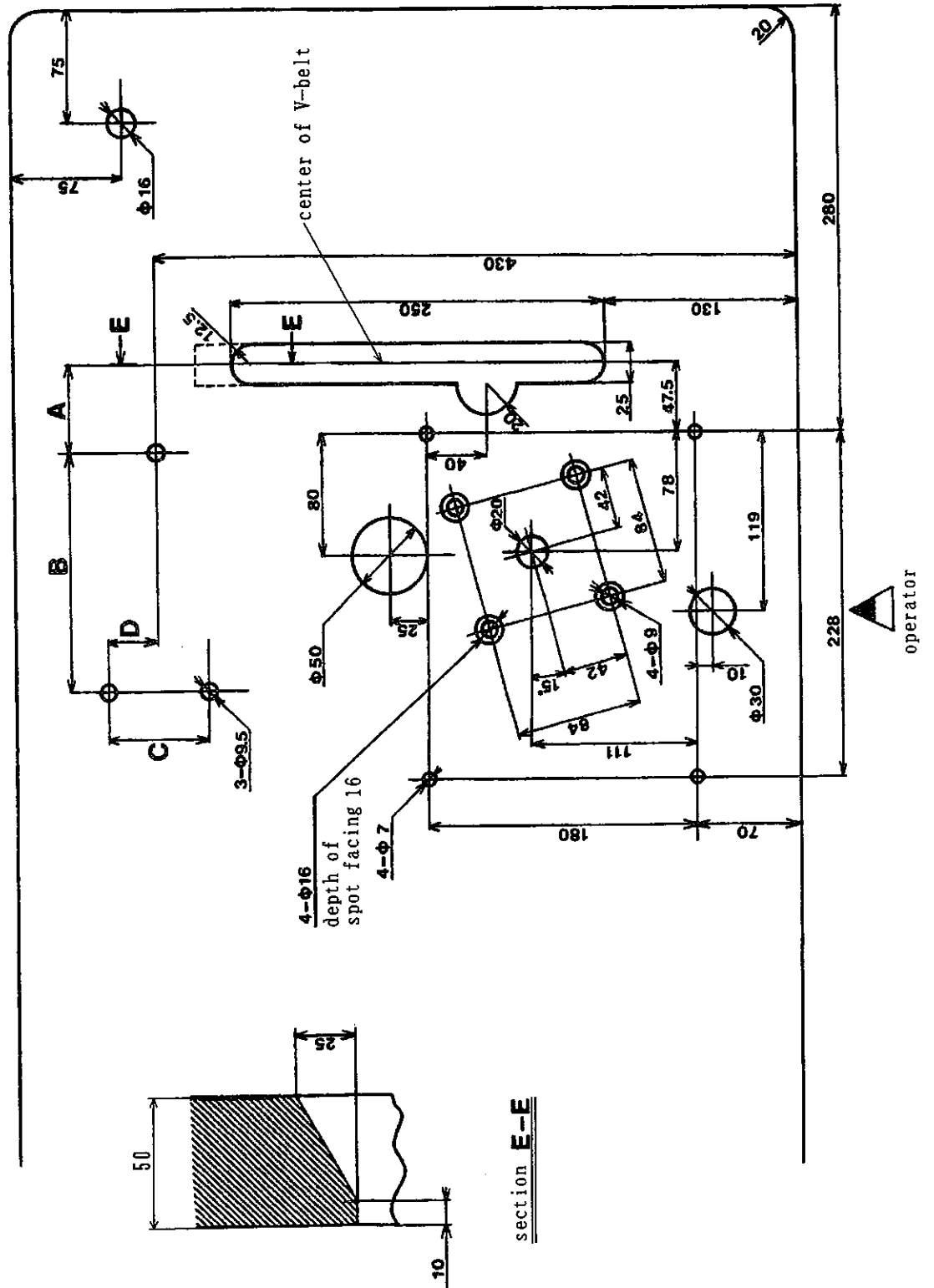

2 . Installation

2-2 Table top installation

See the figure and install correctly.

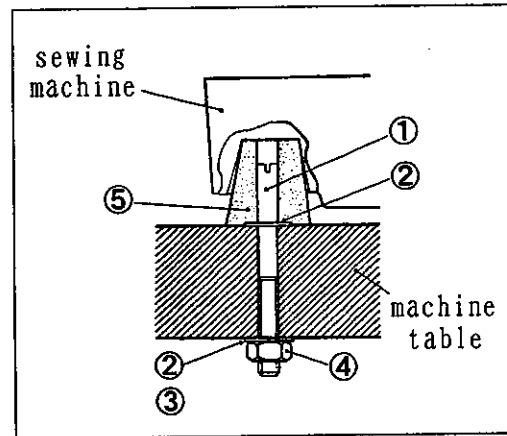
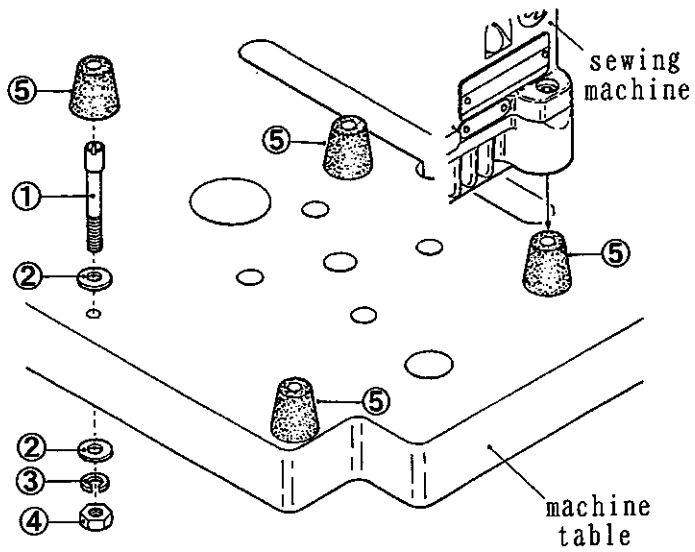

2 . Installation

2-3 Motor and belt

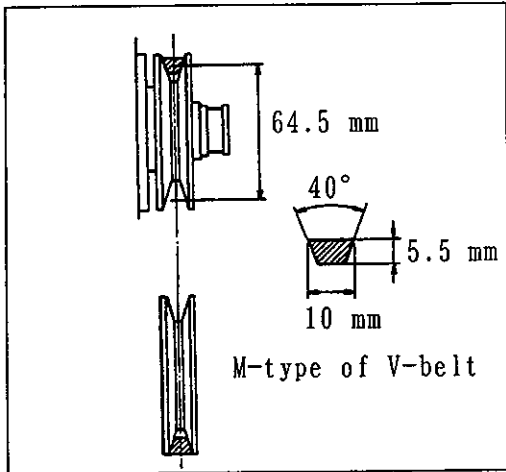

outside diameter of motor pulley (mm)	s.p.m. of machine for	
	50 Hz	60 Hz
90		4500
100		5000
105	4500	
110		5500
120	5000	
125		
130	5500	

See the instruction manual for the motor to be used and install the motor properly.

Install the clutch motor so that the center of the motor pulley and the machine pulley are aligned when the motor pulley shifts to left by pressing down the pedal.

For your reference, the table shows the outside diameters of the motor pulley and s.p.m. of the machine when using the clutch motor of 3-phase, 2-pole, 400 W (1/2 HP).

A commercial pulley is provided at intervals of 5 mm in outside diameter. The outside diameters on the table are the nearest size to the calculated value.

⚠ CAUTION

If a proper motor pulley is not used, s.p.m. of the machine may exceed the maximum speed. The machine may be broken.

2 . Installation

2-4 Engaging belt

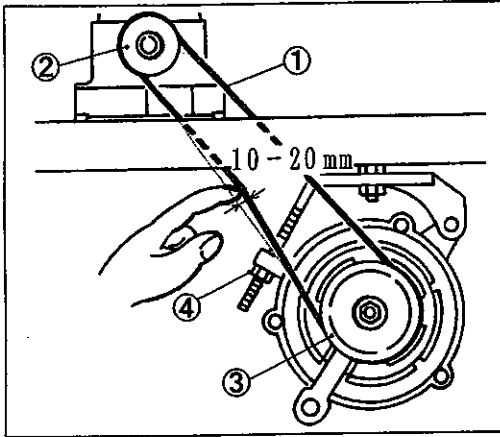

WARNING

ALWAYS turn OFF the motor switch and check that the motor stops before engaging the belt.

The M-type of V-belt should be used.

- (1) Engage the belt ① with the machine pulley ②, and then with the motor pulley ③ while turning the machine pulley ② manually.
- (2) Adjust so that the tension of the belt is 10 mm - 20 mm with the nut ④ when its middle is pressed with finger.
- (3) After adjusting, lock with the nut ④.

2-5 Installing belt cover

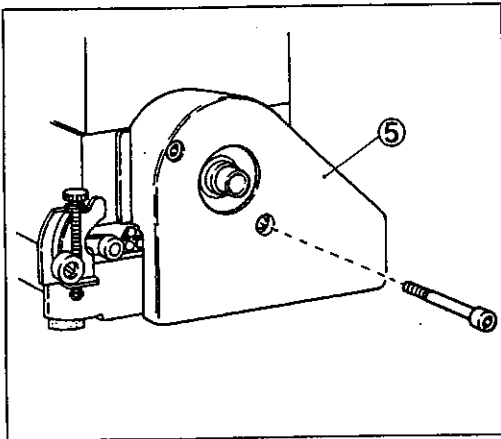

WARNING

To prevent you from injuring yourself and a material from being caught by the belt, be sure to install the belt cover.

- (1) Install the belt cover ⑤ as shown in the figure.
- (2) Install the belt cover support ⑥ while pressed the support ⑥ to the cover ⑤ as shown in the figure.
- (3) Fix the belt cover(lower) ⑦ to the machine table. (only for the table top type)

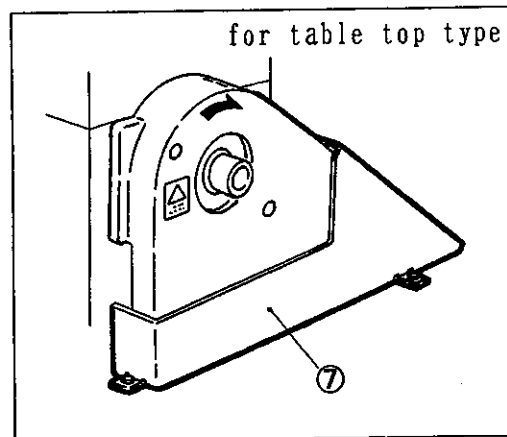
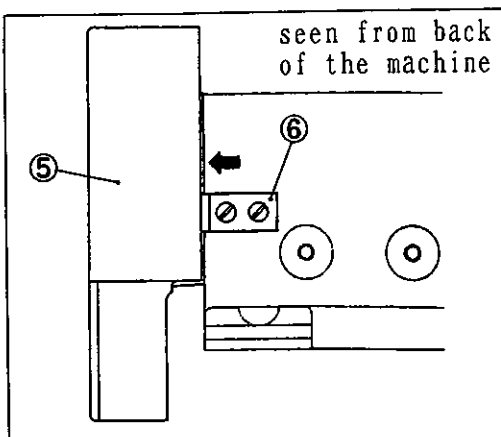

2 . Installation

2-6 Installing eye guard and finger guard

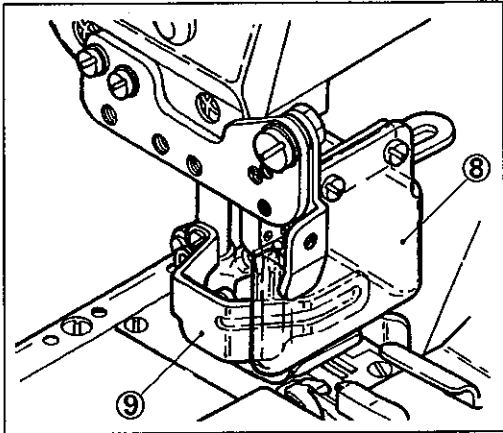

To ensure the safety use, ALWAYS use the machine with the eye guard⑧ and the finger guard⑨.

3. Sewing speed and rotating direction of pulley

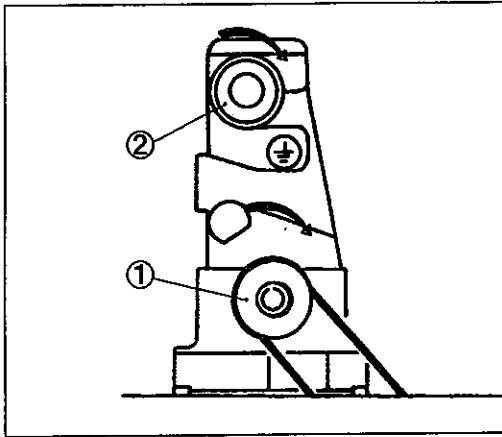

The maximum sewing speed is 5500 s.p.m. in the intermittent operation (with the puller: max. 5000 s.p.m.). To ensure long service life under good conditions, your new machine should be run at 4500 s.p.m. during the first 200 hours (approximately one month).

The rotating direction of the pulley① and the handwheel② is clockwise as shown in the figure.



CAUTION

If the pulley is reversed, oil can not be supplied properly. It may cause the machine problem.

4 . Lubricating oil

WARNING

ALWAYS turn OFF the motor switch and check that the motor stops before the work.

4-1 Lubricating oil to be used

The Yamato SF oil No.28 should be used as lubricating oil.

CAUTION

NEVER add additives to the oil. If added, it promotes the deterioration of the oil and cause a machine trouble.

4-2 Supplying oil

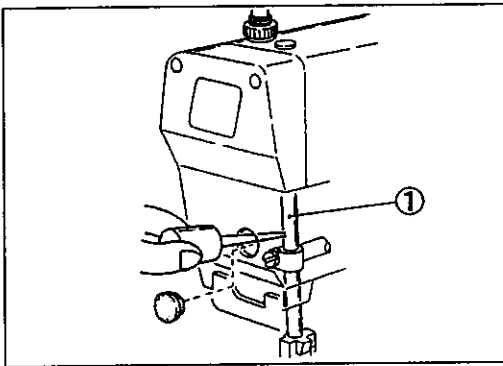

If you use a new machine or a machine which has not been run for a while, oil the needle bar① and the looper bar② 2 or 3 drops.

For supplying oil, open the top cover seal plug③ indicated 'OIL' and supply the oil until the upper line of the oil sight gauge④. After that, close the plug③.

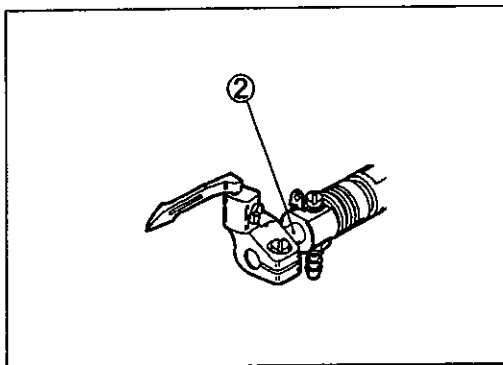

When running the machine, check oil splashes from the nozzle with the oil sight window⑤. If oil does not come out from the nozzle, see the section '4-4 Checking and replacing oil filter' on page 10.

CAUTION

Too much oil or too little oil may cause oil leakage or machine trouble. Be sure to keep the oil level between the lines. If too much lubricating is done, oil may be scattered. A material may be stained.

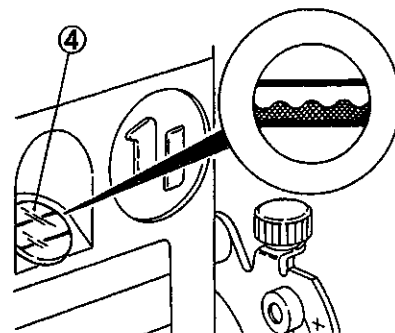
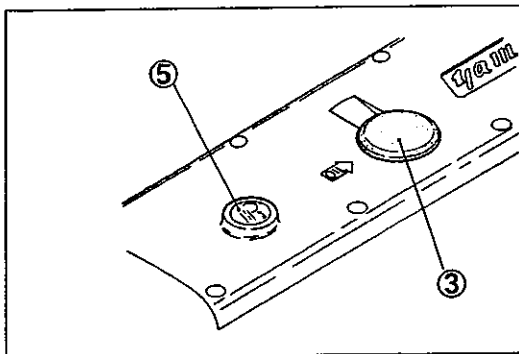

4 . Lubricating oil

WARNING

ALWAYS turn OFF the motor switch and check that the motor stops before the work.

4-3 Replacing oil

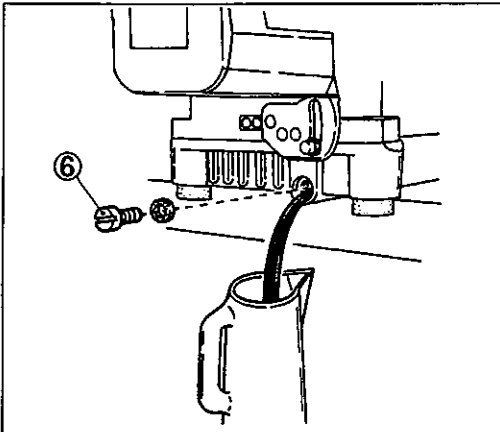

Oil should be replaced in one month since the machine began to be operated. After that, oil should be replaced every six months.

The procedure for replacement is as follows:

- (1) Remove the screw⑥ and drain away oil.
- (2) Tighten the screw⑥.
- (3) Supply new Yamato SF oil No.28. (See the section '4-2 Supplying oil' on page 9.)

4-4 Checking and replacing oil filter

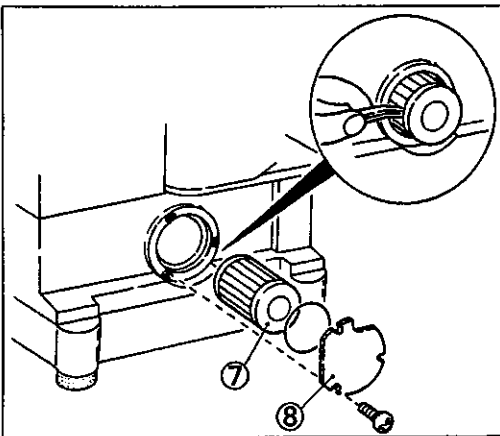

If the oil filter⑦ is clogged with dust, lubrication can not be done properly. The oil filter cover⑧ and the oil filter⑦ should be removed to be checked every six months. If the filter⑦ is clogged or ripped, clean or replace it with a new one. And also, though oil is sufficiently kept, if little oil splashes from the nozzle of the oil sight window or many bubbles are included, check or replace it.

NOTE

Take care not to spill oil stayed in the oil filter⑦.

5. Proper operation

5-1 Needle to be used

Japanese size	9	10	11	12	13	14
Metric size	65	70	75	80	85	90

The needle to be used is UY×128GAS (UY128GAS). Depending on the thickness and material of the fabric, the proper needle should be selected.

5-2 Installing needle

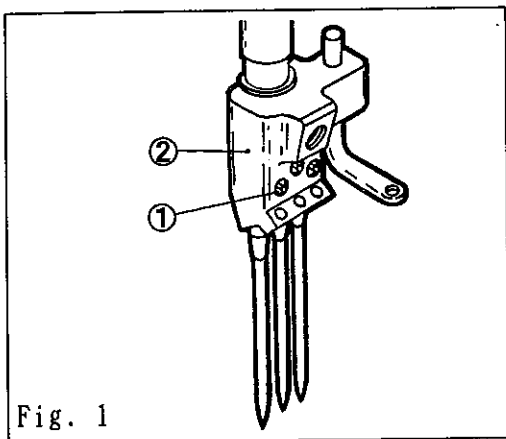

Fig. 1

WARNING

ALWAYS turn OFF the motor switch and check that the motor stops before installing the needles.

- (1) Loosen the screw ① with screwdriver. (Fig. 1)
- (2) Remove the old needle with tweezers.
- (3) See the figures 2 and 3 and insert a new needle into the needle clamp ② facing its scarf to the right back.
- (4) Tighten the screw ① with screwdriver.

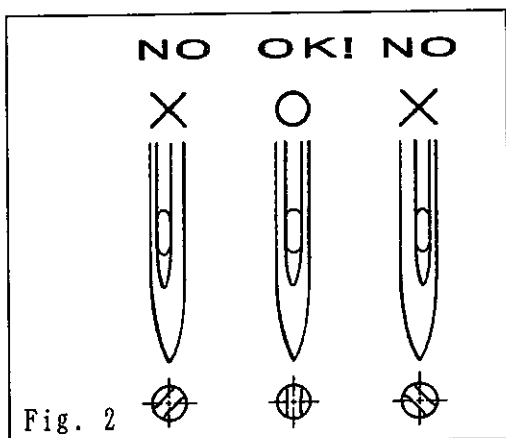

Fig. 2

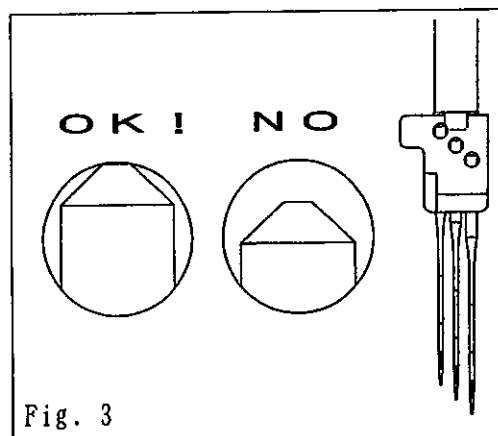

Fig. 3

5 . Proper operation

5-3 Threading



☆ Needle thread

Pull thread until it reaches the front of the needles. And, cut off knots just before needle eye to rethread.

Thread needle thread for left needle as it is in the inmost recess as illustrated.

☆ When had been threaded, knot the preset thread and new one together to rethread.

☆ When not threaded, see this threading chart to thread correctly.

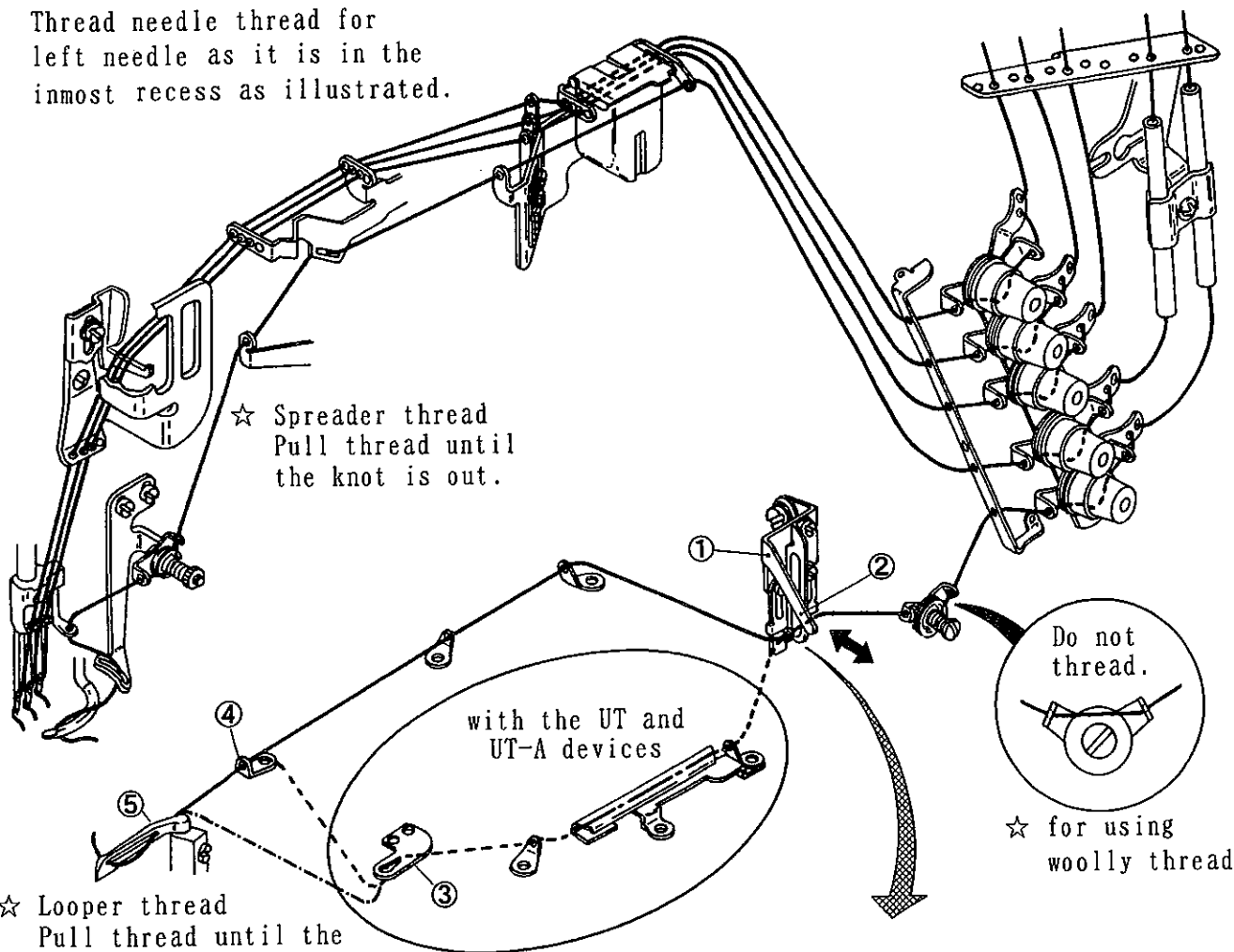

☆ Spreader thread
Pull thread until the knot is out.

with the UT and UT-A devices

☆ Looper thread

Pull thread until the knot is out. Then, cut off the knot.

(Notice) Threading for sewing with "UT" or "UT-A".

* For standard type, thread looper^⑤ through looper thread eyelet(left)^④.

* For cotton thread and polyester thread, thread looper^⑤ without threading looper eyelet(left)^④.

Note: For easy threading, pull the lever^② in the thread take-up eyelet holder^①. After threading, restore the holder^① to the operating position with the lever^②.

☆ for using woolly thread

5. Proper operation

5-4 Adjusting thread tension

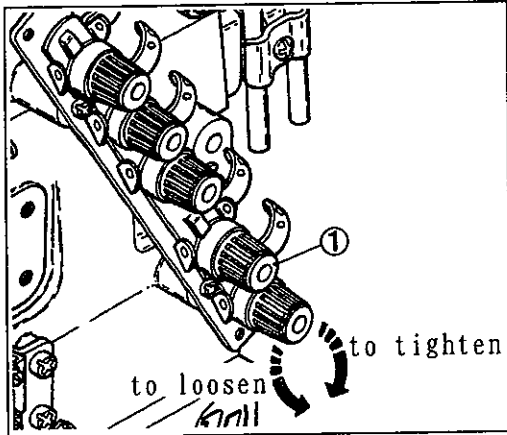

Thread tension should be adjusted with the thread tension spring caps depending on thread type, fabric type, seam width, stitch length and other sewing conditions.

To tighten thread tension, turn the caps clockwise. To loosen, turn the caps ① counterclockwise.

5-5 Presser foot pressure

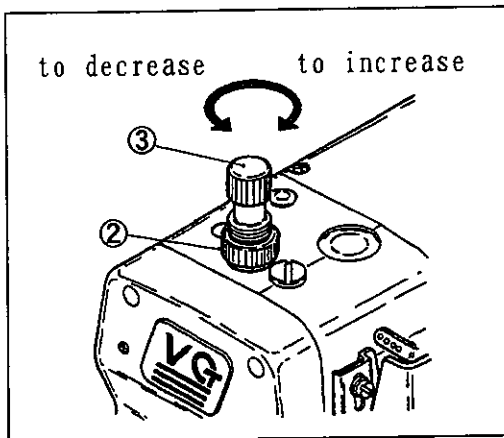

The pressure should be minimized so long as stable stitches can be formed.

- (1) Loosen the lock nut ②.
- (2) To increase the pressure according to the fabric, turn the adjusting screw ③ clockwise. To decrease, turn counterclockwise.

5-6 Adjusting the position of presser foot

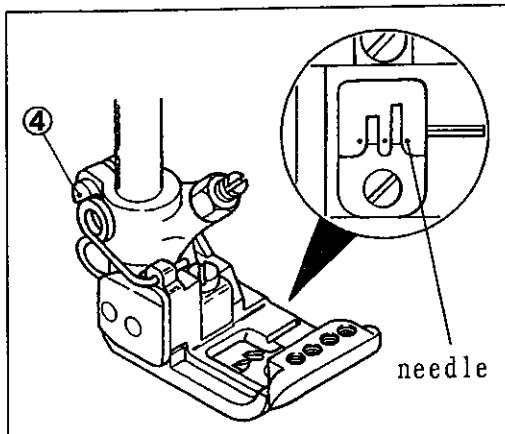

WARNING

ALWAYS turn OFF the motor switch and check that the motor stops before adjustment.

- (1) Loosen the screw ④.
- (2) Move the front of the presser foot right and left so that the needles can drop to the center of the needle hole.
- (3) Tighten the screw ④.

5 . Proper operation

WARNING

ALWAYS turn OFF the motor switch and check that the motor stops before adjustment.

5-7 Adjusting stitch length

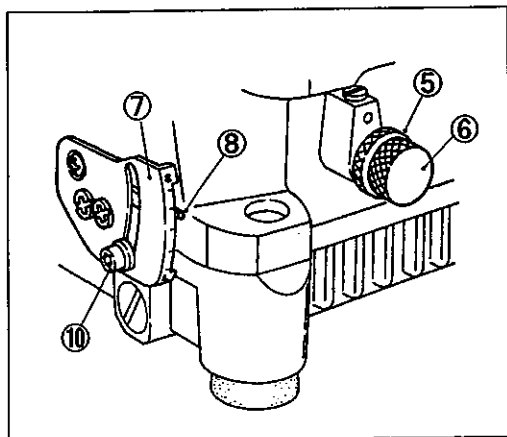

Stitch length is adjustable from 1.4 mm to 3.6 mm. The following table shows the number of stitches per inch (25.4 mm) and 30 mm converted stitch length.

stitch length (mm)	number of stitch per	
	inch	30 mm
1.4	18	21
2.0	13	15
3.0	8.5	10
3.6	7	8

The stopper^⑨ has been fixed so as to stop at 3.6 mm at the maximum with the screw^⑩ at the factory.

The procedure for adjustment is as follows:

- (1) Loosen the lock nut^⑤.
- (2) Turn the adjusting screw^⑥ to adjust the end^⑧ of the main feed lever to the required position seeing the main feed graduations^⑦.

To shorten the stitch length, turn the adjusting screw^⑥ clockwise.

To lengthen, turn counterclockwise.

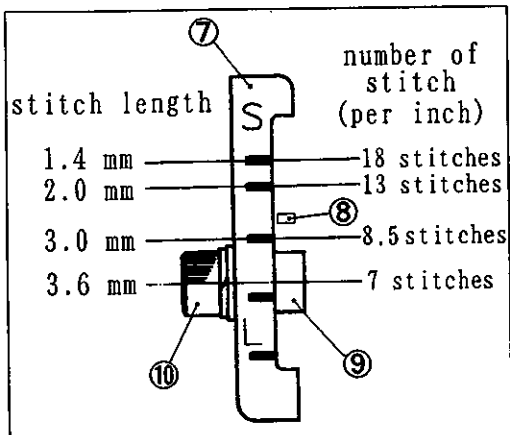

5. Proper operation

5-8 Adjusting movement of differential feed dog (differential feed)

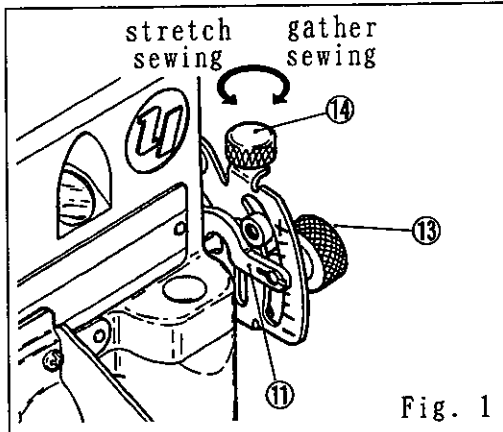

Fig. 1

The differential ratio has been set from 1:0.9 to 1:1.4 at the factory.

When the differential feed lever (right) (11) is aligned with the line (12), the movement of the differential feed dog is the same as that of the main feed dog (differential ratio 1:1) resulting in uniform sewing.

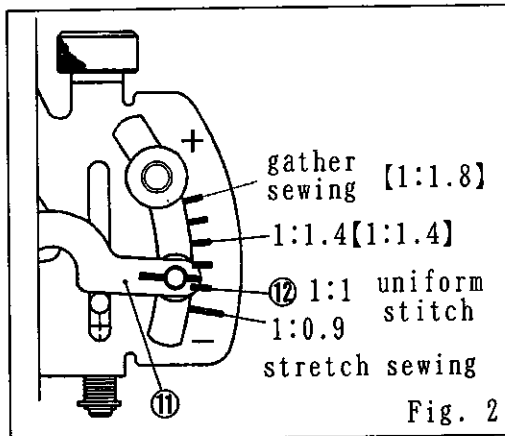

Fig. 2

- (1) Loosen the lock nut (13).
- (2) For gather sewing, turn the adjuster (14) clockwise and the movement of the differential feed dog is increased. For stretch sewing, turn counterclockwise and the movement is decreased.
- (3) Tighten the lock nut (13) securely.

5-9 Setting differential ratio to 1:1.4 - 1:1.8

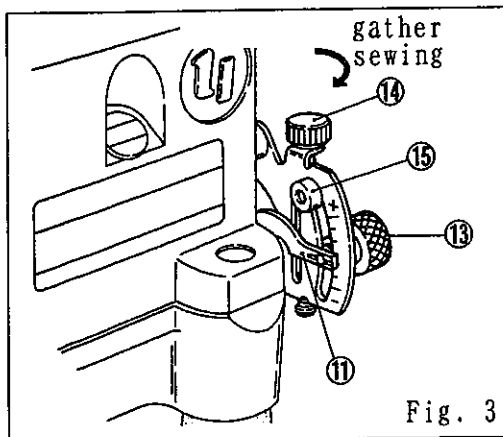

Fig. 3

See the figures 2 and 3.

- (1) Adjust the stitch length to 2.5 mm or less.
- (2) Loosen the screw of the stopper (15) and move the stopper (15) to the top.
- (3) Loosen the lock nut (13) and turn the adjuster (14) clockwise and then raise the differential feed lever (right) (11) until it touches the stopper (15).
- (4) Tighten the lock nut (13).

NOTE

The stitch length of the main feed dog in differential ratio 1:1.8 is max. 2.5 mm.

5. Proper operation



WARNING

ALWAYS turn OFF the motor switch and check that the motor stops before the work.

5-10 Setting differential ratio to 1:0.6 - 1:1.1

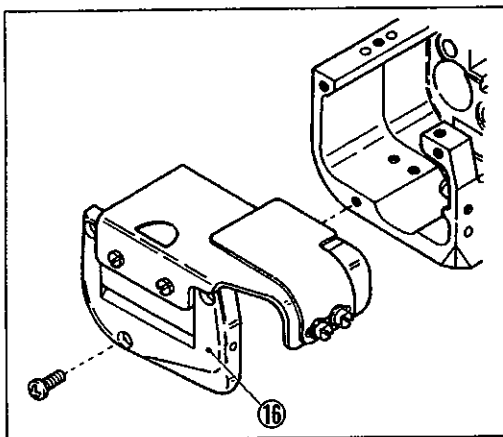

- (1) Remove the side cover (16). (3 pieces of screws)
- (2) Remove the screw (18) of the differential feed bar connections (17).
- (3) Fix the differential feed bar connections (17) to the tapped hole (19) with the removed screw (18).

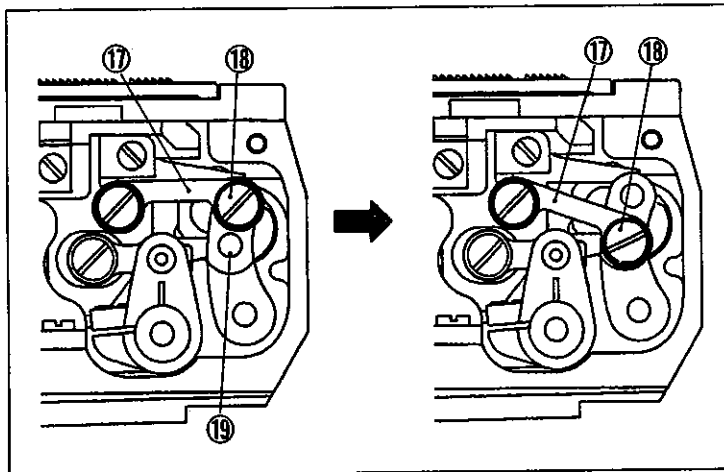
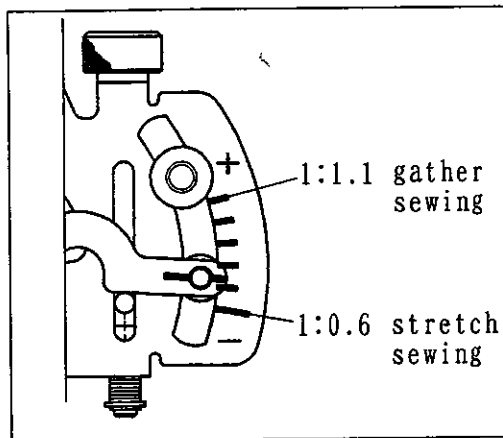

5. Proper operation

WARNING

ALWAYS turn OFF the motor switch and check that the motor stops before the work.

5-11 SP device and HR device

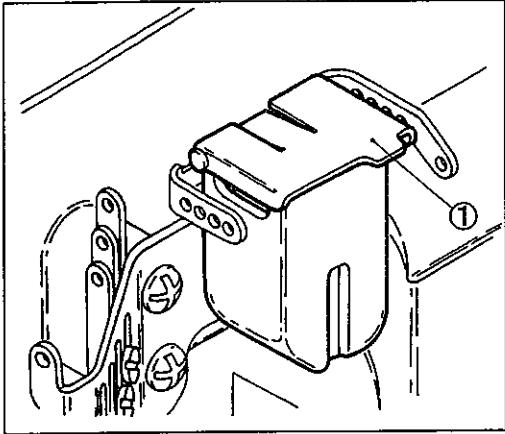

When running the machine at high speed or using synthetic thread and/or synthetic fabric, the SP device (needle thread oiling) equipped with standard (excluded some models) should be used to prevent thread breakage and skipping stitch.

HR device (needle point cooling) is optional. The dimethyl silicone oil should be used.

The lid① of the SP container and the lid② of the HR container should be opened to check the oil level sometimes.

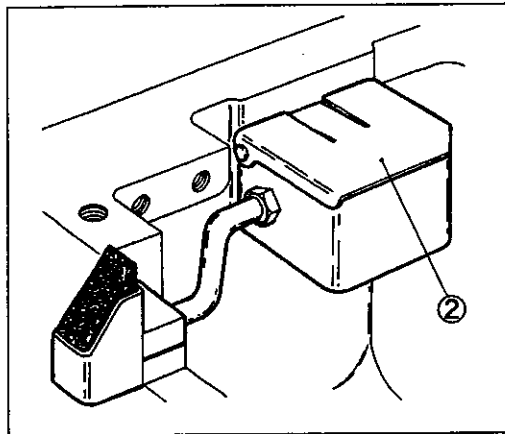

CAUTION

If the silicone oil is attached to the parts other than the SP and HR devices, it causes machine trouble. Be sure to wipe it away.

5-12 Cleaning the machine

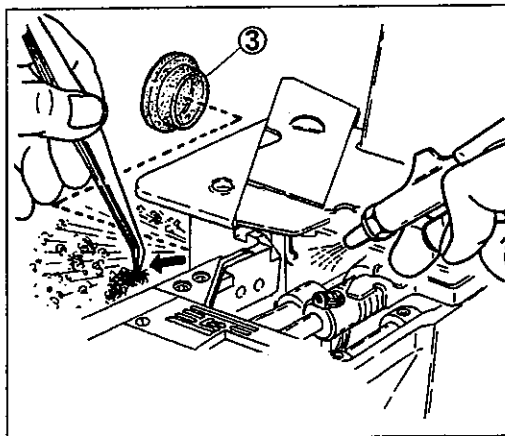

Clean waste thread and dust inside of the machine at the end of work each day.

Remove the seal plug③ at the back of the machine and clean the grooves in the stitch plate, feed dog area, and oil filter screen area once a week.

NOTE

If the oil filter screen is clogged with dust oil in the cylinder does not return to the oil reservoir. It causes oil leakage.

6 . Adjustment of sewing machine



WARNING

ALWAYS turn OFF the motor switch and check that the motor stops before adjustment.

6-1 Position of needle thread eyelet

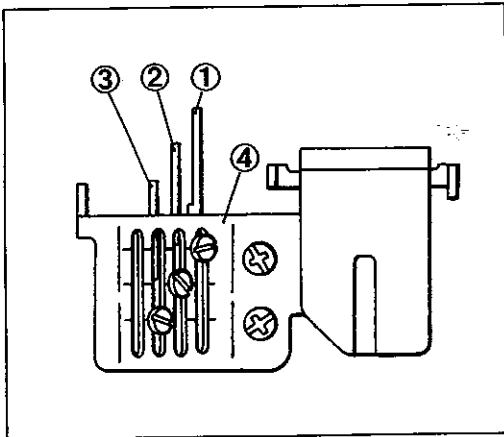

The standard positions of each needle thread eyelet are shown in the figure. Care should be taken so that the center of the screws is aligned with the following lines on the needle thread eyelet bracket④.

- right needle thread eyelet①: top line
- middle needle thread eyelet②: middle line
- left needle thread eyelet③: bottom line

To tighten needle thread, raise the needle thread eyelet. To loosen, lower the eyelet.

6-2 Position of needle thread guide

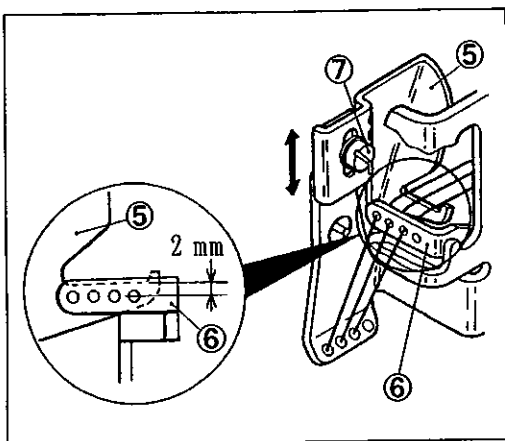

The standard position is that the distance is 2.0 mm from the center of the eye in the needle thread take-up⑥ to the top of the needle thread guide⑤ when the take-up⑥ is at its bottom.

To make needle thread loop bigger or when stretchable thread is used, loosen the screw⑦ and raise the needle thread guide⑤.

To make the loop smaller, loosen the screw⑦ and lower the guide⑤.

6 . Adjustment of sewing machine



WARNING

ALWAYS turn OFF the motor switch and check that the motor stops before adjustment.

6-3 Position of thread take-up eyelet

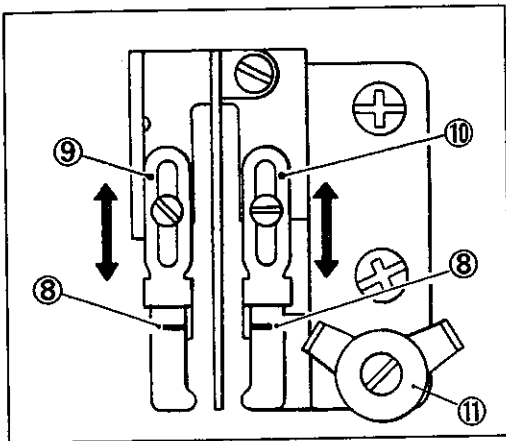

The standard position is that the eyes of the thread take-up eyelets (left) ⑨ and (right) ⑩ are aligned with the lines ⑧ on the thread take-up eyelet holder.

To loosen looper thread, loosen the screws of the eyelets ⑨ and ⑩ and lower the eyelets ⑨ and ⑩. To tighten, loosen the screws of the eyelets and raise the eyelets ⑨ and ⑩.

NOTE

For using woolly thread, move the eyelets ⑨ and ⑩ to their bottom. Do not thread to the tension disc ⑪.

6. Adjustment of sewing machine

6-4 Adjusting relation between needle and spreader



WARNING

ALWAYS turn OFF the motor switch and check that the motor stops before adjustment.

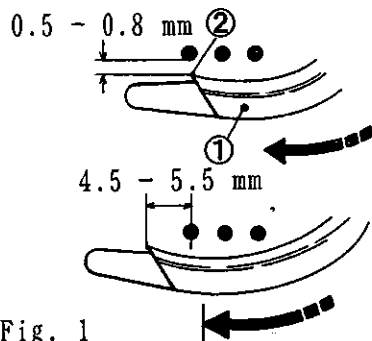

Fig. 1

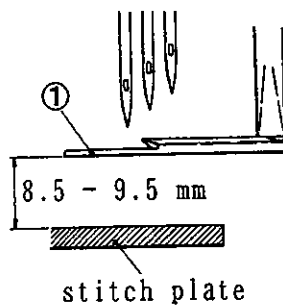

Fig. 2

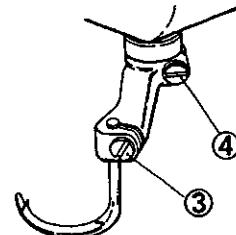

Fig. 3

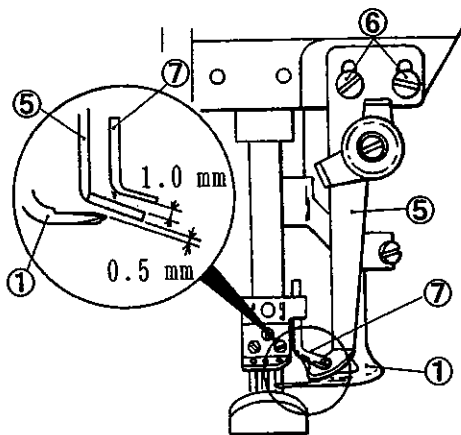

Fig. 4

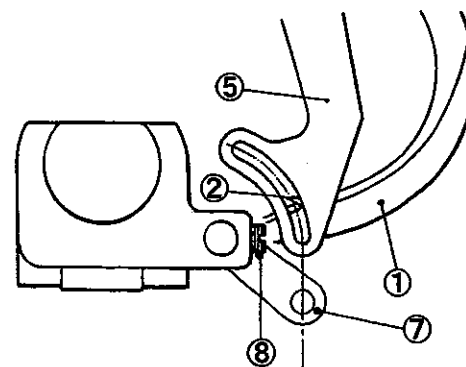

Fig. 5

6-4-1 Adjusting spreader

- (1) Loosen the screws ③ and ④ to make a distance of 0.5 mm - 0.8 mm between the left needle and the hook ② of the spreader ①. (Fig. 3, Fig. 1)
- (2) When reaching the spreader ① to the extreme left, make a distance of 4.5 mm - 5.5 mm from the center of the left needle to the hook ② and tighten the screw ④. (Fig. 1, Fig. 3)
- (3) Make a height adjustment of 8.5 mm - 9.5 mm from the stitch plate to the spreader ① and tighten the screw ③. (Fig. 2, Fig. 3)

6-4-2 Adjusting top cover thread guide

- (1) Loosen the screws ⑥. (Fig. 4)
- (2) Make a distance of 0.5 mm from the top cover thread guide ⑤ to the spreader ①. (Fig. 4)
- (3) When reaching the spreader ① to the extreme right, adjust the guide ⑤ so that the hook ② meets the center line of the slot in the guide ⑤. Check that the hook ② can catch thread securely. (Fig. 5)
- (4) Tighten the screws ⑥. (Fig. 4)

6. Adjustment of sewing machine

6-4-3 Adjusting top cover thread eyelet

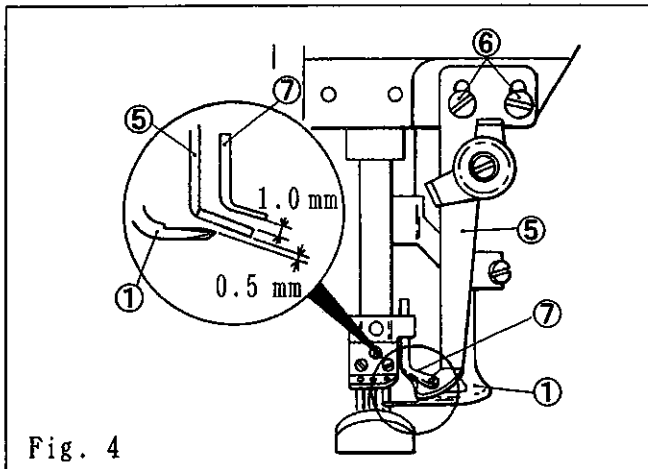

Fig. 4

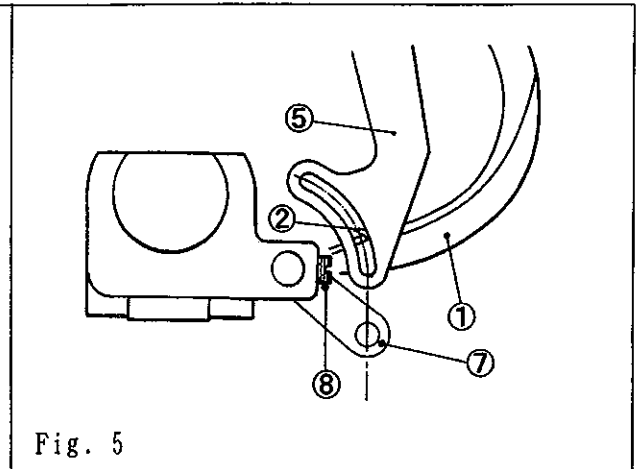
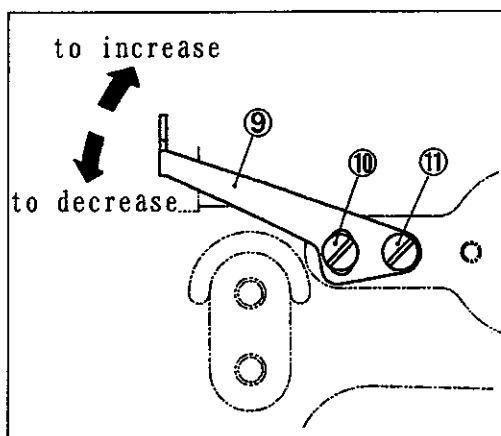

Fig. 5

- (1) Loosen the screw⑧. (Fig. 5)
- (2) When the needle bar is at its bottom, make a distance of 1.0 mm from the guide⑤ to the top cover thread eyelet⑦. (Fig. 4)
- (3) Align the eye of the eyelet⑦ with the straight imaginary line from the guide⑤ as shown in the figure 5.
- (4) Tighten the screw⑧. (Fig. 5)

6-5 Adjusting top cover thread eyelet(upper)



The standard condition is that the center of the slot in the top cover thread eyelet(upper)⑨ is aligned with the center of the screw⑩ as shown in the figure.

To increase the feed of top cover thread, loosen the screws⑩ and ⑪ and raise the eyelet(upper)⑨.

To decrease, lower the eyelet(upper)⑨.

NOTE

For using stretchable thread like woolly, adjust the eyelet(upper)⑨ higher than usual.

6 . Adjustment of sewing machine



WARNING

ALWAYS turn OFF the motor switch and check that the motor stops before adjustment.

6-6 Distance between needle and looper

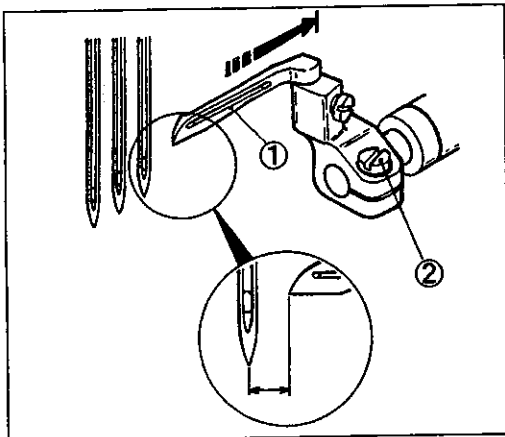

The distance between the looper point and the center of the right needle depends on needle distance when the needles are at their bottom and the looper① is at its extreme right.

See the following table and loosen the screw② to adjust the distance.

NOTE

Even if the distance between the needles is different, the distance between the center of the needle bar and the looper point is 6.0 mm.

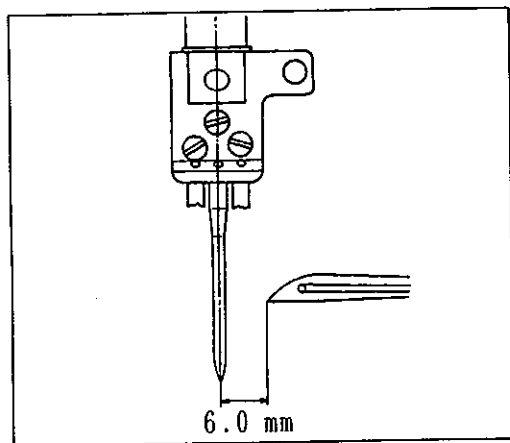

needle distance (mm)	mark on gauge	mark on gauge	distance between needle and looper (mm)
3.2	(32)	A	4.4
4.0	(40)	B	4.0
4.8	(48)	C	3.6
5.6	(56)	D	3.2
6.4	(64)	E	2.8

For easy adjustment of the distance between the needle and looper, the timing gauge (95220) should be used. The gauge is an extra part. Please place an order with our agents or directly with us, if required.

6. Adjustment of sewing machine



WARNING

ALWAYS turn OFF the motor switch and check that the motor stops before adjustment.

6-7 Using timing gauge

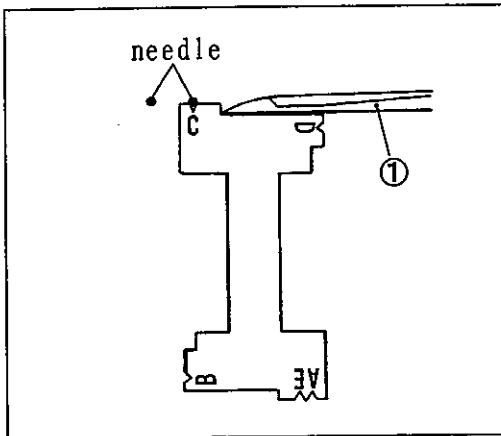

The gauge has the marks (A, B, C, D, E) for each needle distance.

- (1) Loosen the screw②.
- (2) When the looper is at its extreme right, keep fitting the right needle into the notch of the corresponding needle distance, and fit the looper point to the gauge.
- (3) Tighten the screw②.

6-8 Adjusting needle height

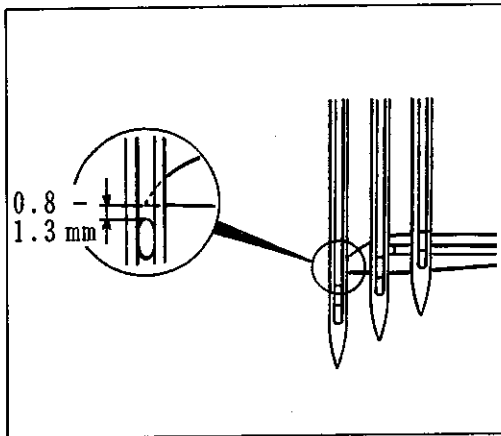

- (1) Install a needle to the left hole in the needle clamp.
- (2) Check the looper is inserted into the looper holder fully.
- (3) Turn the handwheel until the looper point meets the center of the left needle.
- (4) Loosen the screw③ and move the needle bar up and down so that the looper point can pass 0.8 mm - 1.3 mm above the needle eye.
- (5) Tighten the screw③. Check that the needles can drop to the center of the needle hole in the stitch plate.

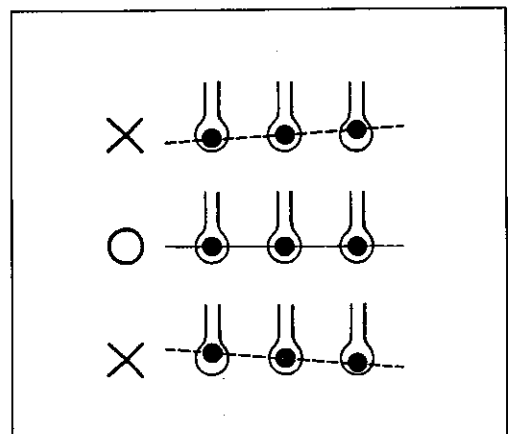
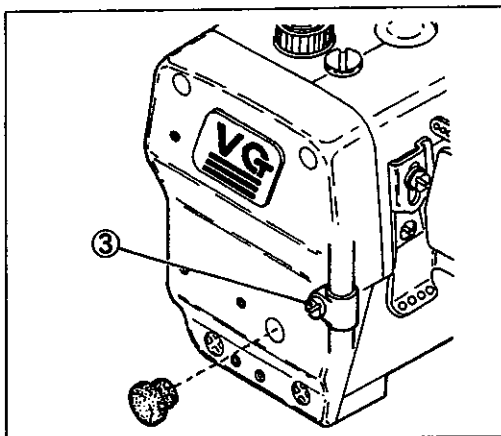

6 . Adjustment of sewing machine



WARNING

ALWAYS turn OFF the motor switch and check that the motor stops before adjustment.

6-9 Longitudinal position of needle and looper

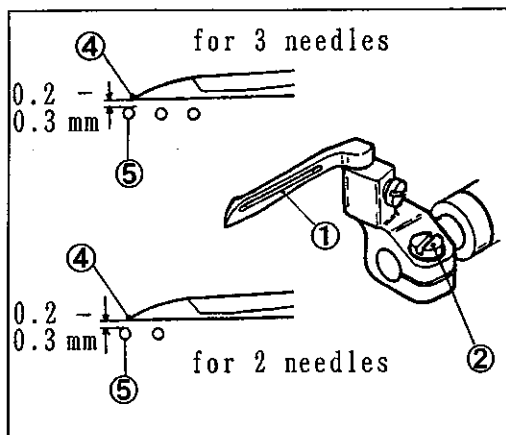

- (1) Turn the handwheel until the looper point④ meets the center of the left needle⑤.
- (2) Loosen the screw② and adjust the looper holder back and forth so that the distance between the back of the left needle⑤ and the looper point is 0.2 mm - 0.3 mm.
- (3) Tighten the screw②.

NOTE

When tightening the screw②, the longitudinal position of the looper may be shifted. After tightening, check the position again.

6 . Adjustment of sewing machine



WARNING

ALWAYS turn OFF the motor switch and check that the motor stops before adjustment.

6-10 Adjusting needle and needle guard(rear)

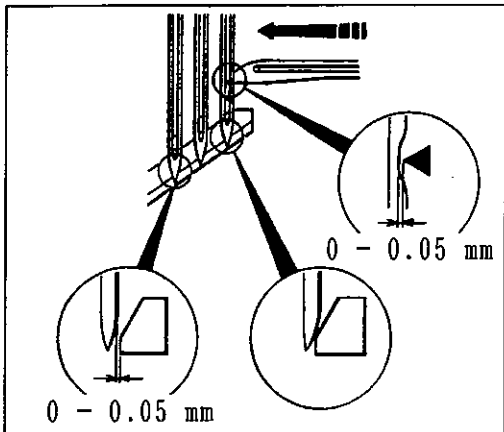
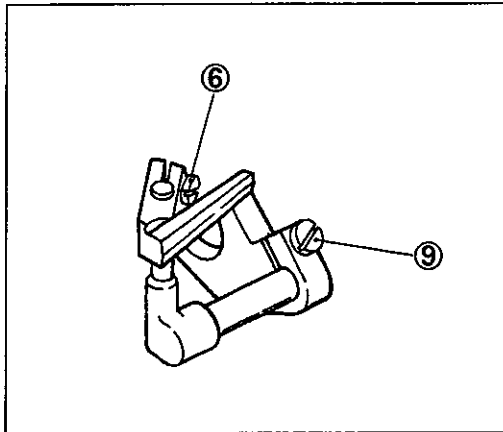
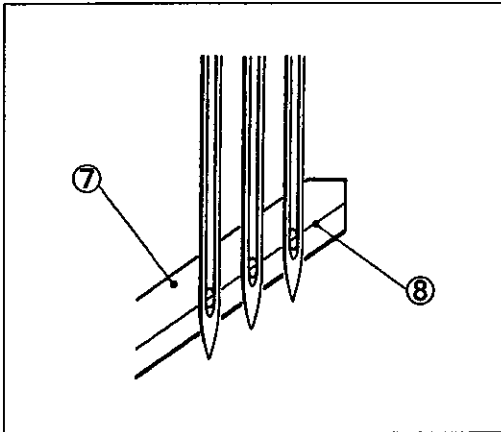

- (1) Turn the handwheel clockwise to lower the needles to their bottom.
- (2) Loosen the screw⑥.
- (3) Align the line⑧ on the needle guard(rear)⑦ with the center of the needle eye of the needles.
- (4) Tighten the screw⑥.
- (5) Turn the handwheel until the looper point meets the center of the right needle.
- (6) Loosen the screws⑥ and ⑨ and adjust the guard(rear)⑦ back and forth so that the distance between the right needle and the looper point is 0 - 0.05 mm.
- (7) Turn the handwheel to check the distance is 0 - 0.05 mm between the left needle and the looper point.
- (8) Tighten the screws⑥ and ⑨.

6 . Adjustment of sewing machine

WARNING

ALWAYS turn OFF the motor switch and check that the motor stops before adjustment.

6-11 Adjusting needle and needle guard(front)

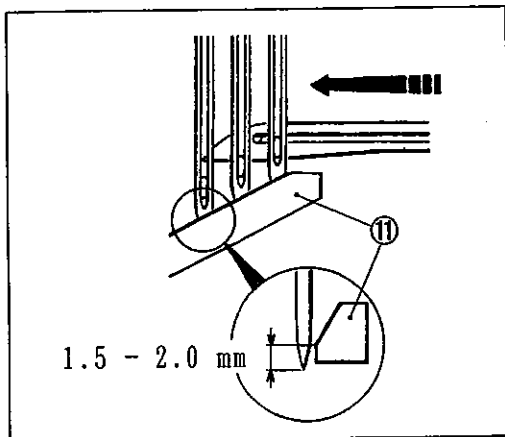

- (1) Turn the handwheel clockwise until the looper point meets the center of the left needle.
- (2) Loosen the screw ⑩ and adjust the height so that the distance is 1.5 mm - 2.0 mm from the needle point to the angular part of the needle guard(front) ⑪.
- (3) Tighten the screw ⑩.
- (4) Loosen the screws ⑩ and ⑫ and adjust so that the distance from the needle guard(front) ⑪ to the left needle and the right needle is 0 - 0.3 mm.
- (5) Tighten the screws ⑩ and ⑫.

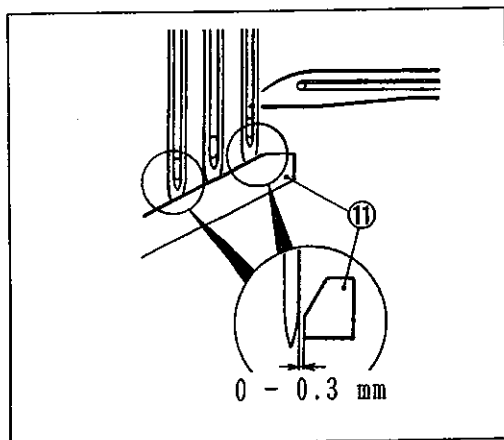
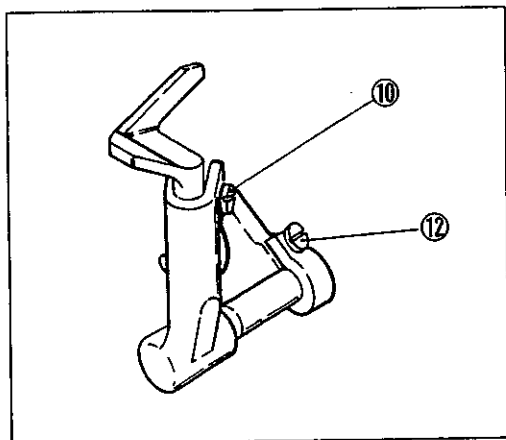

6 . Adjustment of sewing machine



WARNING

ALWAYS turn OFF the motor switch and check that the motor stops before adjustment.

6-12 Height of feed dog

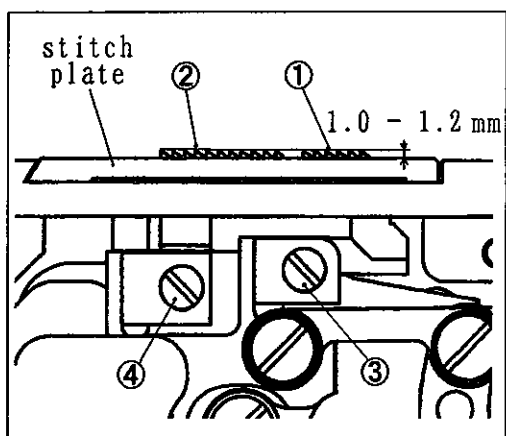

The standard condition is that the height of the feed dogs is 1.0 mm - 1.2 mm from the top of the stitch plate and the differential feed dog① and the main feed dog② are parallel with the top of the stitch plate when the feed dogs are at their top.

Loosen the screws③ and ④ before adjustment.

6. Adjustment of sewing machine

WARNING

ALWAYS turn OFF the motor switch and check that the motor stops before adjustment.

6-13 Adjusting presser foot lift

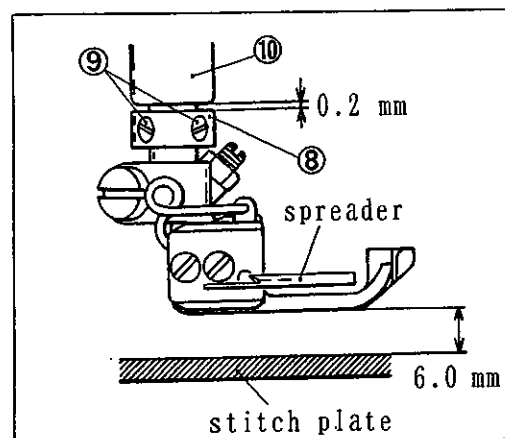
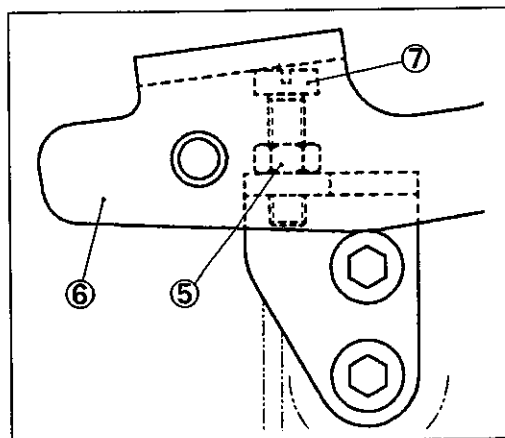
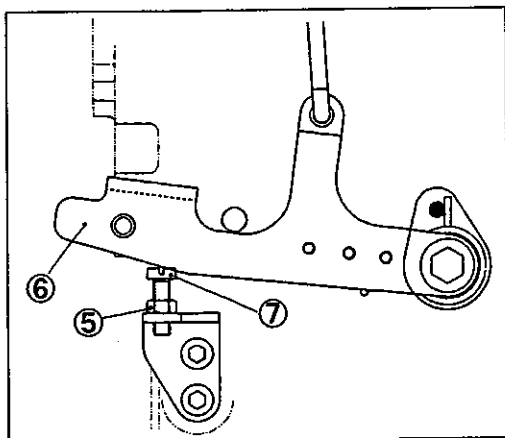

The presser foot lift for needle distance 5.6 mm is as follows:

- with spreader: 6.0 mm
- with no spreader: 7.5 mm

- (1) Loosen the lock nut⑤.
- (2) Press down the lifter lever⑥ to make a distance of 6.0 mm (7.5 mm) between the stitch plate and the presser foot.
- (3) When the presser foot is raised by 6.0 mm (7.5 mm), adjust so that the screw⑦ and the lever⑥ are touched.
- (4) Tighten the nut⑤.
- (5) Loosen the screws⑨ of the collar⑧.
- (6) When the presser foot is raised by 6.0 mm (7.5 mm), make a distance of 0.2 mm from the presser bar bushing⑩ and the collar⑧.
- (7) Tighten the screws⑨.

6. Adjustment of sewing machine

6-14 Adjusting feed of puller (for using the machine with puller mechanism)



WARNING

ALWAYS turn OFF the motor switch and check that the motor stops before adjustment.

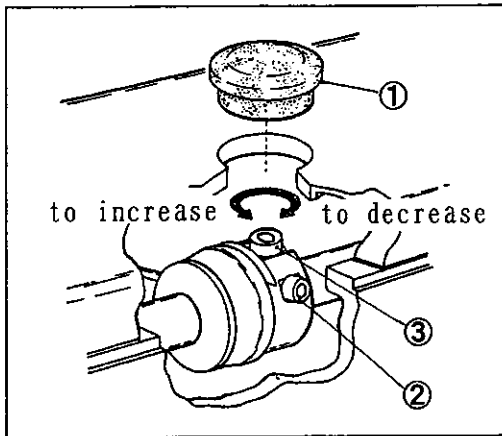

- (1) Remove the top cover seal plug①.
- (2) Turn the handwheel until the screw② of the feed roller eccentric is at the top. Loosen the screw② with screwdriver.
- (3) Turn the handwheel until the screw③ is at the top as shown in the figure.
- (4) To increase the feed of the puller, turn the screw③ counterclockwise. To decrease, turn clockwise.
- (5) After adjustment, tighten the screw② securely with tightening torque 2.5 N·m.

6-15 Pressure of upper feed roller (for using the machine with puller mechanism)

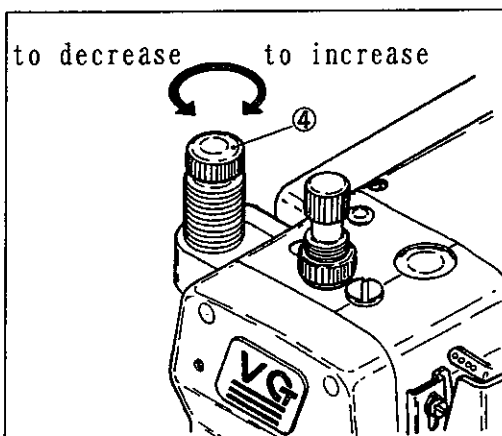

The pressure should be minimized as far as fabric can be fed between the upper and lower rollers.

To increase the pressure, turn the adjusting screw④ clockwise. To decrease, turn the screw④ counterclockwise.

6 . Adjustment of sewing machine

WARNING

ALWAYS turn OFF the motor switch and check that the motor stops before the work.

6-16 Adjustment of hemming folder(left)

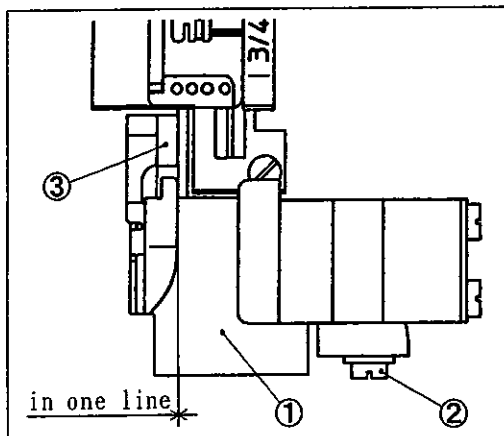

1. Loosen the screw② on hemming folder (left)①.
2. Make the right side surface of guiding part of hemming folder(left)① and the right side surface of upper knife③ to be in one line.
3. Tighten the screw② on hemming folder (left)①.

6-17 Adjustment of trimming width by hemming folder spacer

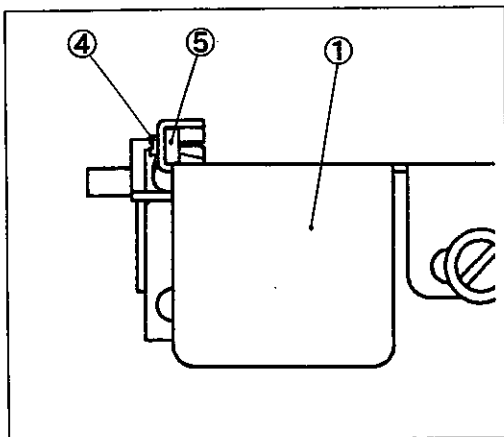

For adjusting the width of fabric to be trimmed, install or remove the hemming folder spacer⑤ on the guiding part of hemming folder (left)①.

With the hemming folder spacer⑤ installed, the width of fabric to be trimmed is 3 mm.
Without the hemming folder spacer⑤ the width of fabric to be trimmed is 5 mm.

To remove the hemming folder spacer⑤, remove the screw④ on the spacer⑤.

6 . Adjustment of sewing machine



WARNING

ALWAYS turn OFF the motor switch and check that the motor stops before the work.

6-18 Adjustment of hemming folder(right)

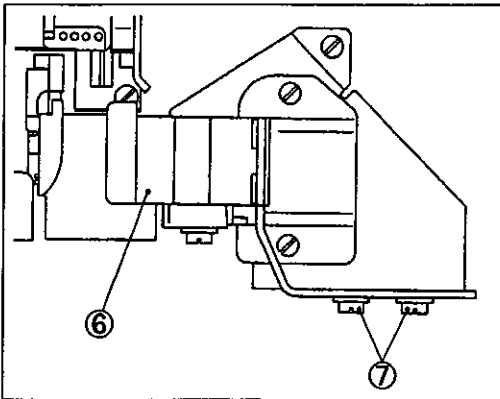

1. Loosen the screw⑦ on hemming folder (right)⑥.
2. Make the hemming folder(right)⑥ and the right side of folded fabric set for the hemming width to be in one line.
3. Tighten the screw⑦ on hemming folder (right)⑥.

6-19 Adjustment of fabric guide(right)

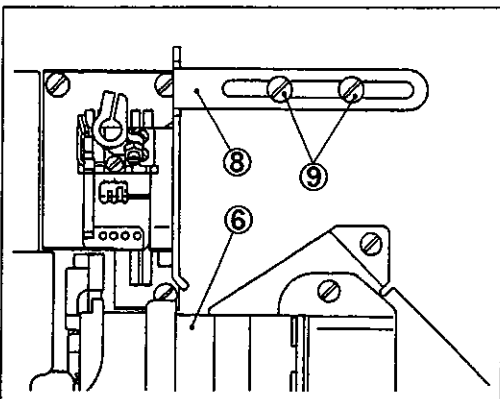

1. Loosen the screw⑨ on fabric guide(right)⑧.
2. Make the left side surface of fabric guide (right)⑧ and left side surface of hemming folder(right)⑥ in one line.
3. Tighten the screw⑨ on fabric guide (right)⑧.

6-20 Exchanging of fabric presser

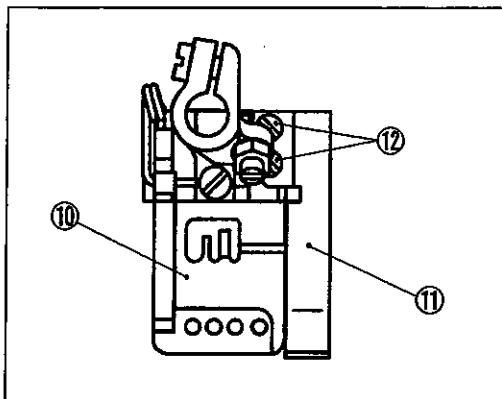

2 pieces of fabric presser(to be fixed on right side of presser foot) with different widths are included in machine head.

- 19.1 mm(3/4inch) : installed on machine
 - 25.4 mm(1 inch) : included in accessory box
- Install proper fabric presser according to hem width.

To remove the fabric presser⑪ remove the screw⑫ on presser foot⑩.

7. Adjustment of knife system



WARNING

ALWAYS turn OFF the motor switch and check that the motor stops before the work.

7-1 Installing accessories

Install the accessories as suction pipe(rear), suction pipe support, flexible hose and speed controller in the machine as the following procedure.

1. Install the speed controller⑧ in the screw hole on the bottom of lower knife holder.
2. Insert the suction pipe(rear)① into the hole on the bottom of lower knife holder bracket② and fix it by the screw③.
3. Remove the screws④ placed at the rear of machine frame.
4. Using the screws④ fix the suction pipe support⑤ in the place the screws④ located.
5. Set the suction pipe(rear)① on the suction pipe support⑤.
6. Insert the flexible hose⑦ fitted with the hose band⑥ in advance into the suction pipe(rear)① and fix the hose⑦ by the band⑥.

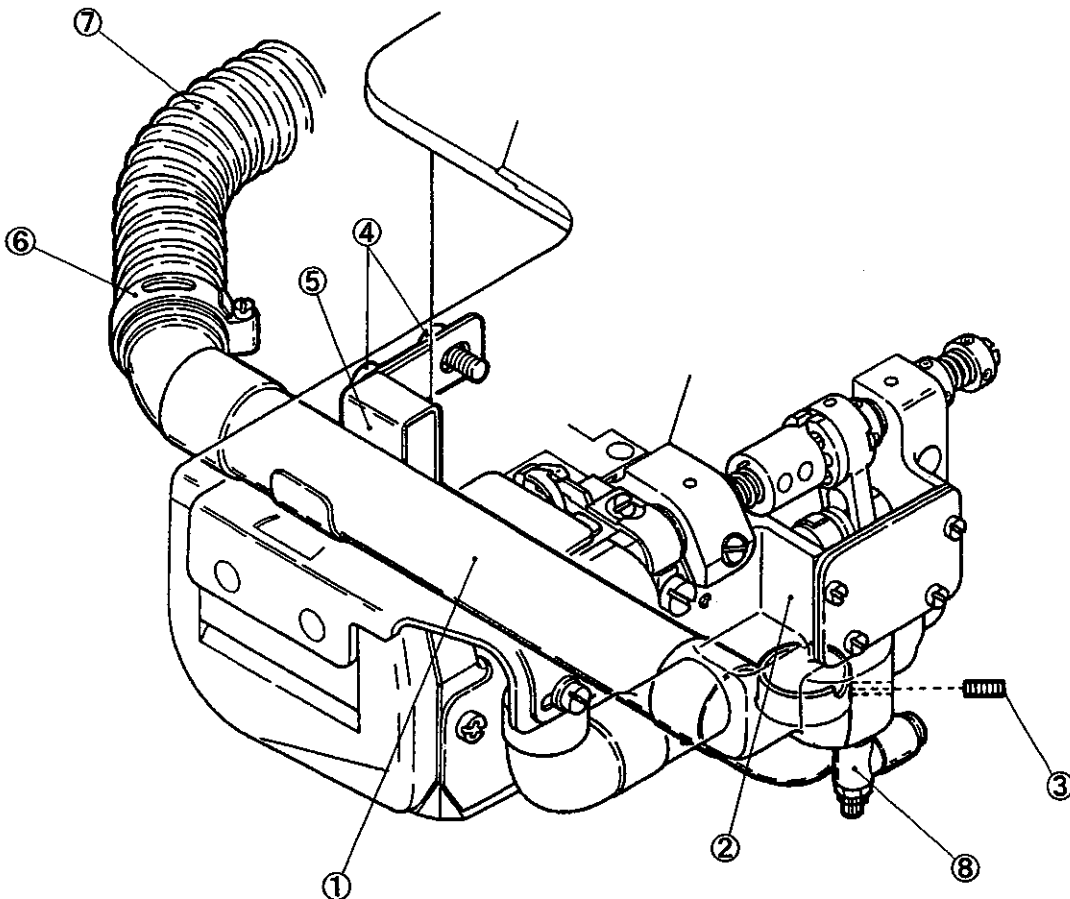

7 . Adjustment of knife system



WARNING

ALWAYS turn OFF the motor switch and check that the motor stops before the work.

7-2 Adjustment of suction pipe(front)

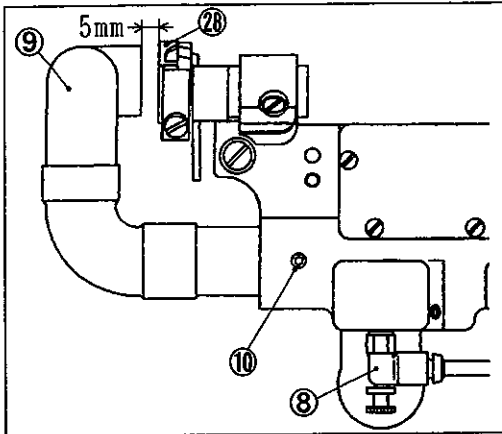

Set the suction pipe(front)⑨ with the clearance of 5 mm from the left side surface of chip receiver⑳.

For adjusting the position of suction pipe (front)⑨ or removing it, loosen the screw⑩.

☆Suction by compressed air.

Adjust the suction power with the speed controller⑧.

Set the suction power for its lowest level enough for suction of the chip.

☆Suction by vacuum system.

Connect the flexible hose to the vacuum dust collector.

Adjust the suction power with the system unit.

Set the suction power for its lowest level enough for suction of the chip.

7-3 Adjustment of suction pipe cover

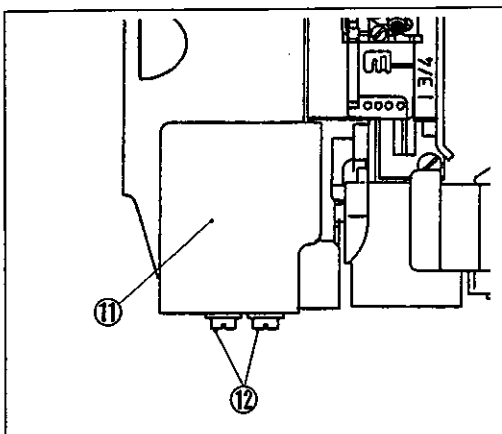

If changing the position of the suction pipe(front)⑨, position of suction pipe cover⑪ should be changed accordingly.

1. Loosen the screw⑫ on suction pipe cover⑪.
2. Make the right side surface of suction pipe cover⑪ and the inlet of the pipe⑨ in one line.
3. Tighten the screw⑫ on suction pipe cover⑪.

7. Adjustment of knife system



WARNING

ALWAYS turn OFF the motor switch and check that the motor stops before the work.

7-4 Trimming width (Cutting position of fabric)

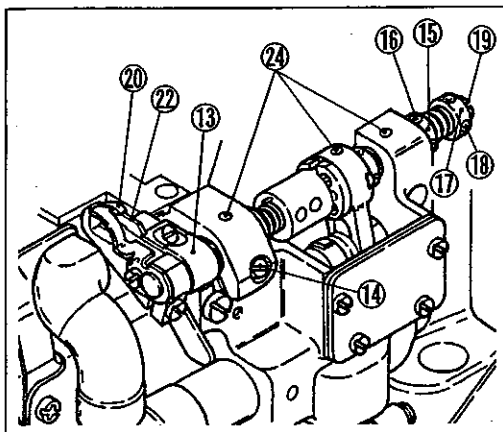

Adjust the width of fabric to be trimmed as the following procedure.

1. Loosen the screw¹⁴ on lower knife holder¹³.
2. Loosen the screw¹⁶ on collar(left)¹⁵.
3. Move the lower knife holder¹³ to the desired position.
4. Tighten the screw¹⁴ on lower knife holder¹³. Torque for tightening is 1.5 - 2 N·m (15 - 20 kgf·cm).
5. Loosen the screw¹⁸ on collar (right)¹⁷ and adjust the pressure of upper knife pressure spring by rotating the adjusting screw¹⁹. (At shipment, the clearance between the left collar¹⁵ and the right collar¹⁷ is set for 9 mm.)
6. Loosen the screw¹⁸ on collar (right)¹⁷.
7. Check if the pressure of upper knife is proper or not by loading a thread between the upper knife²⁰ and the lower knife²² and rotating the handwheel manually.
8. Make the point 7 mm from the tip of upper knife²⁰(the root of upper knife) and the top surface of lower knife¹⁷ in the same level. Then, tighten the screw¹⁶ on collar (left)¹⁵.
9. Check again if the knives cut properly.

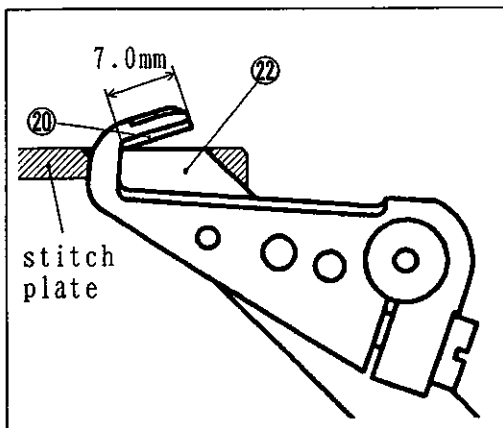

NOTE

Apply some oil into the oil hole²⁴ periodically.

7 . Adjustment of knife system



WARNING

ALWAYS turn OFF the motor switch and check that the motor stops before the work.

7-5 How to remove and install the lower knife

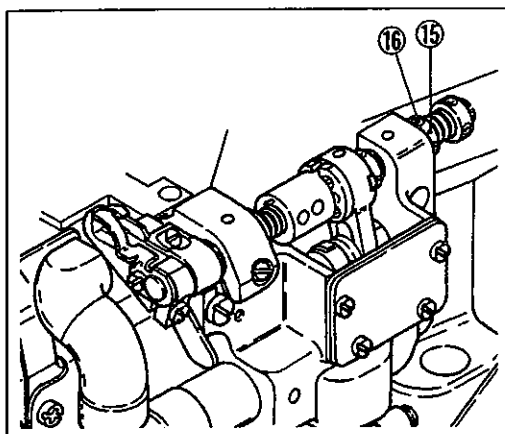

☆How to remove the lower knife.

1. Loosen the screw⑯ on collar(left)⑮.
2. Move the upper knife holder⑳ to the left and make clearance between the upper knife㉔ and the lower knife㉒.
3. Tighten the screw⑯ on collar(left)⑮.
4. Loosen the screw㉓ fixing lower knife㉒ and draw out the lower knife㉒ downward.

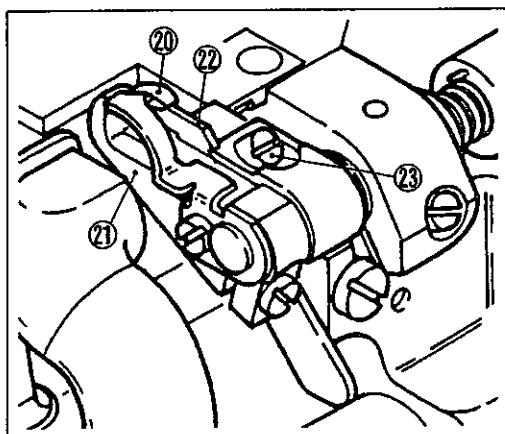

☆How to install the lower knife.

1. Make the tip of lower knife㉒ and the top surface of stitch plate to be on the same level and tighten the screw㉓.
2. As loosening the screw⑯ on the collar (left)⑮ the upper knife㉔ contacts to the lower knife㉒ by the pressure of spring.
3. Check if the pressure of upper knife is proper or not by loading a thread between the upper knife㉔ and the lower knife㉒ and rotating the handwheel manually.
4. Make the point 7 mm from the tip of upper knife㉔(the root of upper knife) and the top surface of lower knife㉒ in the same level. Then, tighten the screw⑯ on collar (left)⑮.
5. Check again if the knives cut properly.

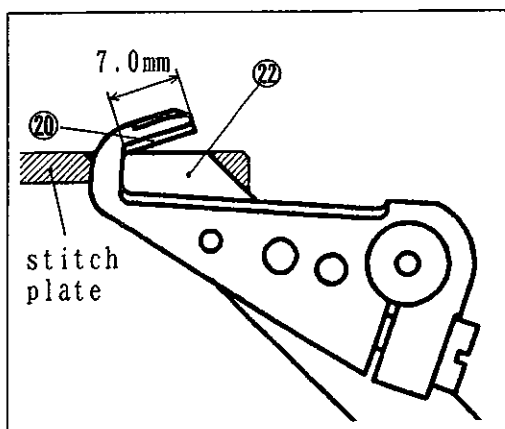

7. Adjustment of knife system



WARNING

ALWAYS turn OFF the motor switch and check that the motor stops before the work.

7-6 How to remove and install the upper knife

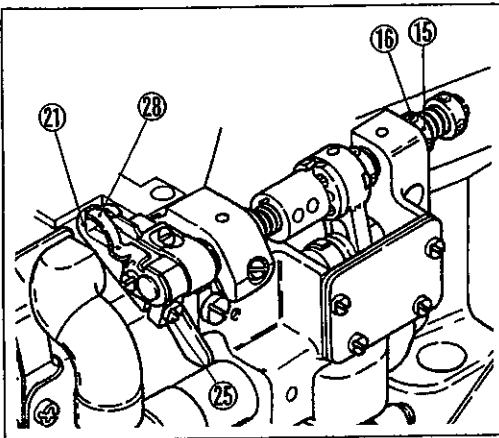

☆How to remove the upper knife.

1. Loosen the screw²⁵ on upper knife holder²¹.
2. Disengage the upper knife holder²¹.
3. Remove the screw²⁶ on upper knife²⁰.
4. Disengage the upper knife²⁰.

☆How to install the upper knife.

1. Contact the upper knife²⁰ to the upper knife holder²¹ with inserting the pin²⁷ of the upper knife holder²¹ into the hole on upper knife²⁰ and tighten the screw²⁶.
2. Install the upper knife holder²¹ on the upper knife shaft²⁹ and tighten the screw²⁵ temporarily.

Distance from the left end of the shaft²⁹ to the left surface of chip receiver²⁸ (installed on the left surface of the holder²¹) should be 1.5 mm.

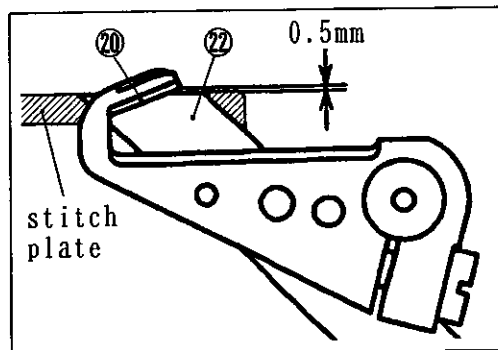
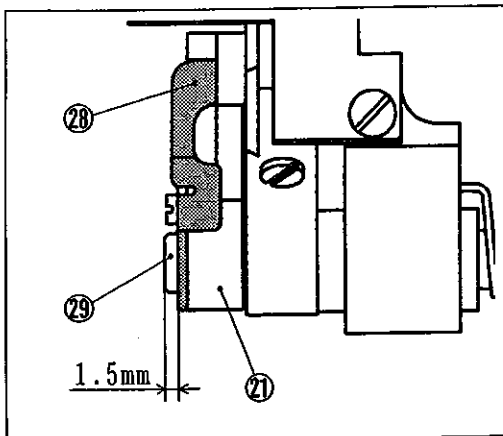
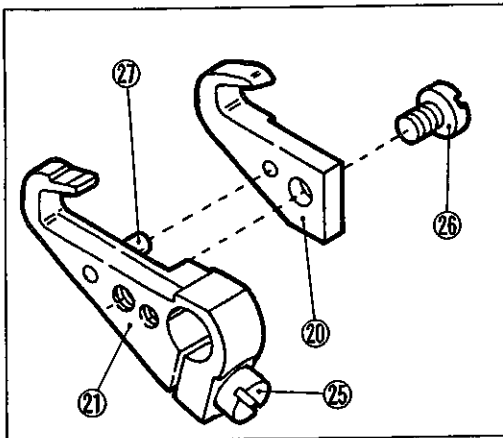

7 . Adjustment of knife system



WARNING

ALWAYS turn OFF the motor switch and check that the motor stops before the work.

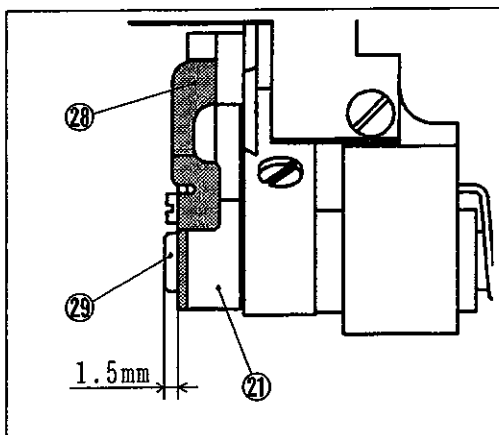
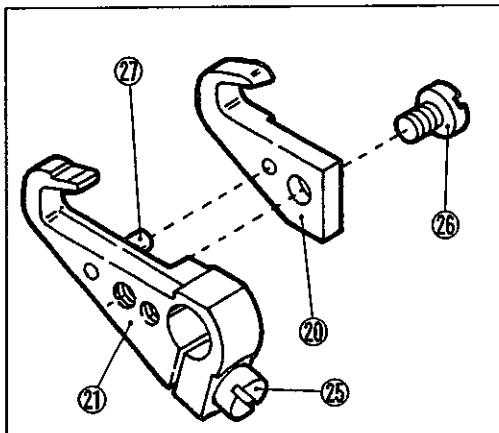
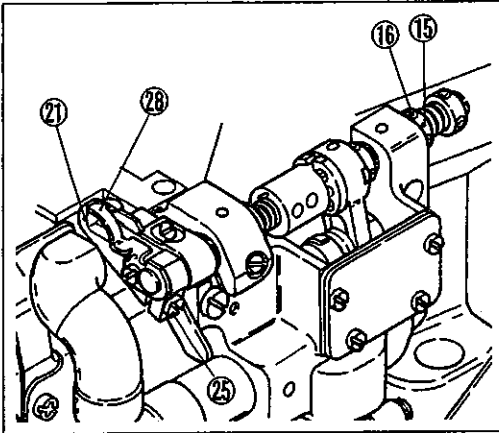

3. Rotate the hand wheel manually to lower the upper knife²⁰.

With the knife²⁰ is at its dead point, move the upper knife holder²¹ to place the tip of upper knife blade at the point 0.5 mm above the top surface of lower knife, then tighten the screw²⁵ on upper knife holder²¹.

4. As loosening the screw¹⁶ on collar(left)¹⁵, the upper knife contacts to the lower knife by the pressure of spring.

5. Check if the pressure of upper knife is proper or not by loading a thread between the upper knife²⁰ and the lower knife²² and rotating the handwheel manually.

6. Make the point 7 mm from the tip of upper knife²⁰(the root of upper knife) and the top surface of lower knife²² in the same level. Then, tighten the screw¹⁶ on collar (left)¹⁵.

7. Check again if the knives cut properly.

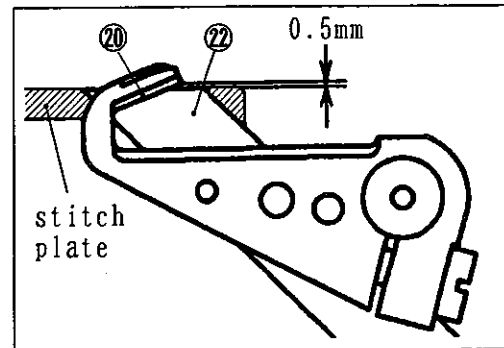

7. Adjustment of knife system



WARNING

ALWAYS turn OFF the motor switch and check that the motor stops before the work.

7-7 Adjustment of upper knife stroke

The stroke of upper knife can be adjusted from 3.0 mm to 4.0 mm. At shipment, it is adjusted 4.0 mm. For changing the stroke of upper knife, see the following procedure.

1. Loosen the screw³⁰ and remove the bracket cover³¹ and the gasket³².
2. Loosen the nut³³ on upper knife adjusting lever pin³⁵.
3. Moving the lever pin³⁵ to the arrow Y direction, the stroke gets smaller and to the arrow X direction makes it bigger.

NOTE

When gaining the upper knife stroke, the position that notch marks³⁴ and ³⁶ matches is its maximum. Do not move the upper knife adjusting lever pin³⁵ to the arrow X direction over the maximum position.

4. Tighten the nut³³ on upper knife adjusting lever pin³⁵.
5. Loosen the screw²⁵ on upper knife holder²¹ to be tightened temporarily.
6. Rotate the handwheel manually to lower the upper knife²⁰. With the knife²⁰ is at its dead point, move the upper knife holder²¹ to place the tip of upper knife blade at the point 0.5 mm above the top surface of lower knife, then tighten the screw²⁵ on upper knife holder²¹.
7. As loosening the screw¹⁶ on collar(left)¹⁵, the upper knife contacts to the lower knife by the pressure of spring.
8. Check if the pressure of upper knife is proper or not by loading a thread between the upper knife²⁰ and the lower knife²² and rotating the handwheel manually.
9. Make the point 7 mm from the tip of upper knife²⁰(the root of upper knife) and the top surface of lower knife²² in the same level. Then, tighten the screw¹⁶ on collar (left)¹⁵.

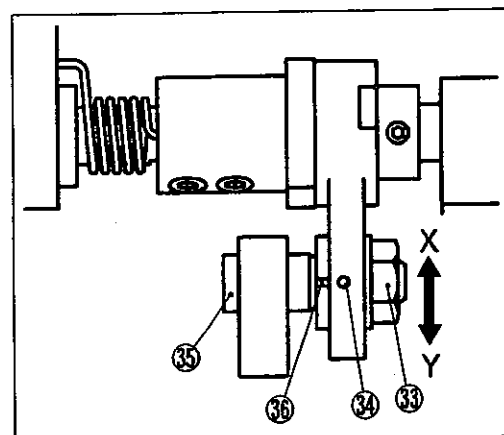
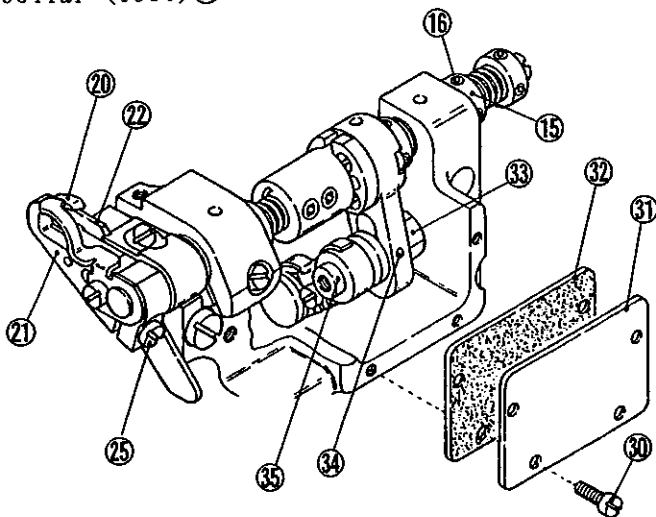

7 . Adjustment of knife system



WARNING

ALWAYS turn OFF the motor switch and check that the motor stops before the work.

10. Check again if the knives cut properly.

11. Install the bracket cover³¹ and the bracket cover gasket³² by the screw³⁰.

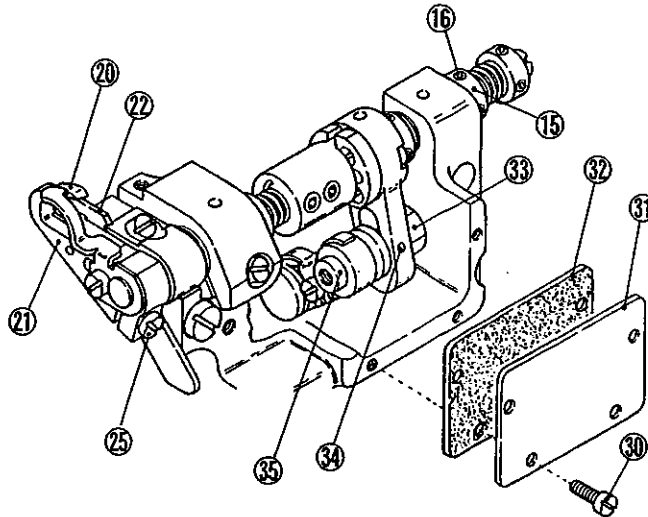

7-8 Sharpening of knives

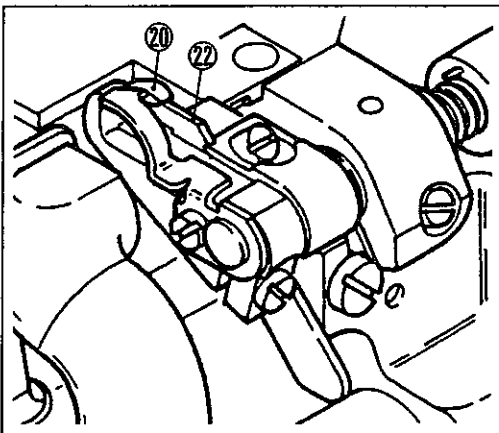

If the sharpness of knives get blunt, re-sharpen the lower knife²³.

Prepare the cold water and re-sharpen the lower knife with keeping it cool.

For re-sharpening, see the left fig.

NOTE

The upper knife is made of super hard alloy and cannot be sharpened with normal grinder. It is recommended to keep the upper knife as a spare part, and contact us directly or the dealer for re-sharpening it.

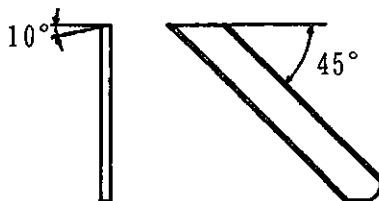

7. Adjustment of knife system



WARNING

ALWAYS turn OFF the motor switch and check that the motor stops before the work.

7-9 How to cancel(stop the movemnet of) left hand knife

Cancel the left hand knife as following procedure.

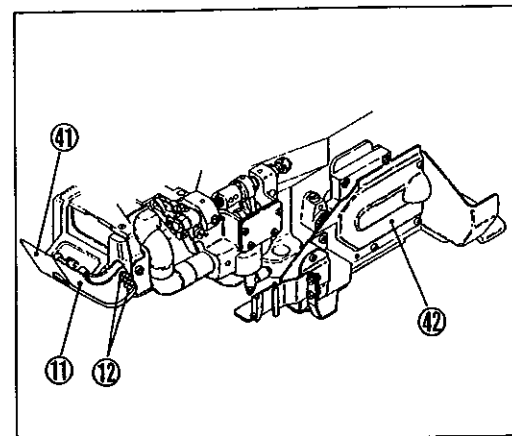
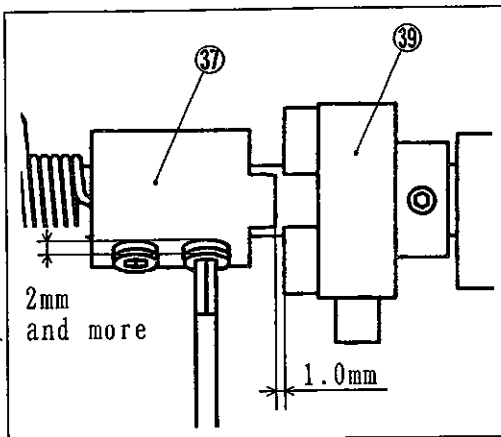
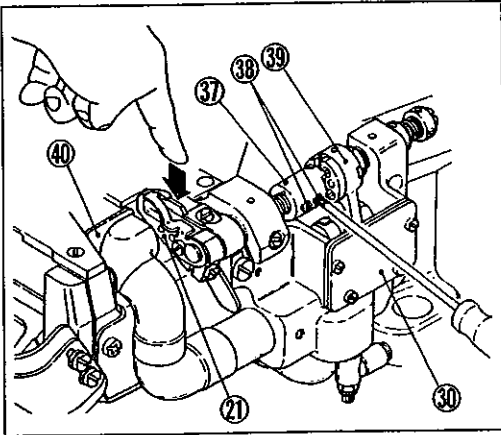

1. Loosen the two screws³⁸ on knife drop collar³⁷. (For following procedure, loosen the screws³⁸ so that the heads of screws³⁸ come out of the collar³⁷ for 2 mm or more.)
2. With the allen wrench set in the one of screws³⁸ on the³⁷, pull out the projection of the collar³⁷ from the groove of upper knife adjusting lever³⁹ 1 mm to the left.
3. With the allen wrench set in the one of screws³⁸ turn the collar³⁷ until the allen wrench hit on the top surface of cover³⁰.
4. Keeping the state above, push down the tip of upper knife holder²¹ gently until it contact the chip guard⁴⁰.
5. Keeping the state above, tighten the screw³⁸ on knife drop collar³⁷.
6. Close the side cover⁴¹.
7. Close the front cover⁴².
8. Loosen the screw¹² on suction pipe cover¹¹.
9. Move the suction pipe cover¹¹ to the right and fill up the clearance.
10. Tighten the screw¹² on suction pipe cover¹¹.

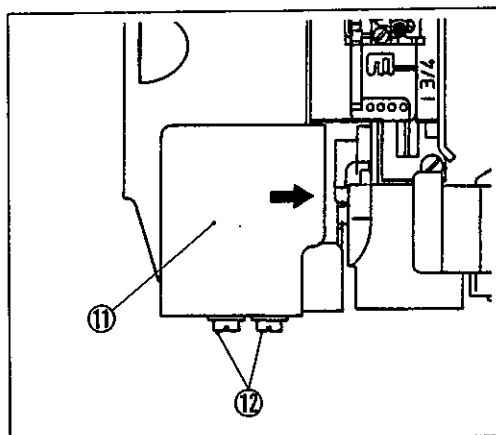

7. Adjustment of knife system



WARNING

ALWAYS turn OFF the motor switch and check that the motor stops before the work.

7-10 How to call off the cancellation of left hand knife

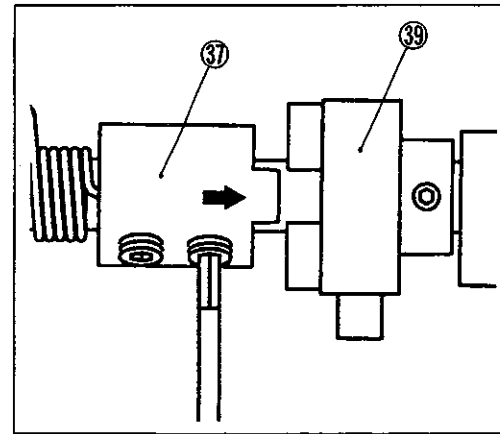
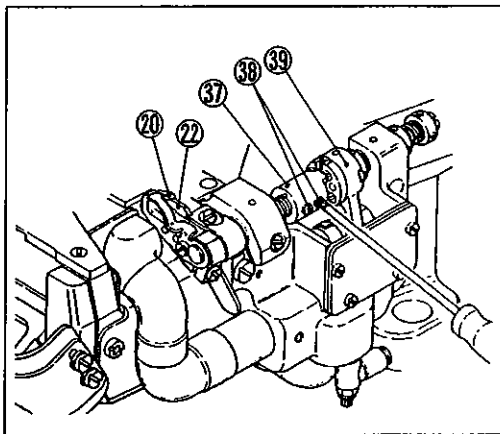
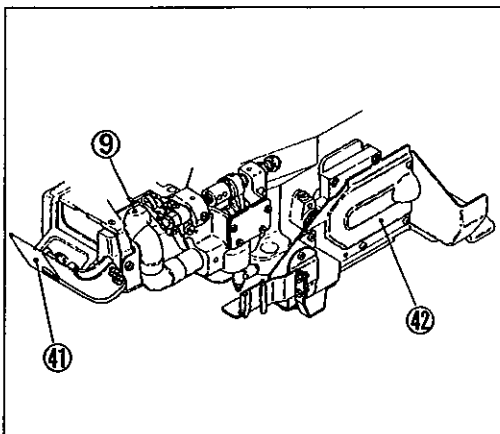
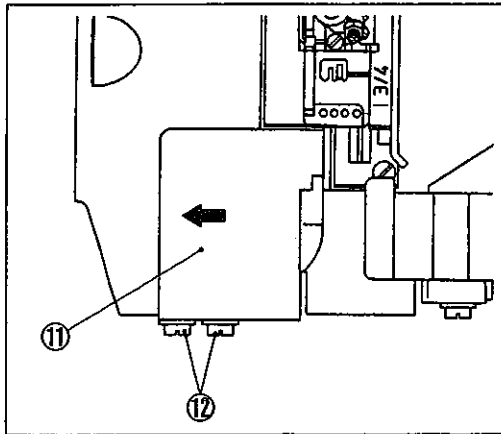

Call off the cancellation of left hand knife as following procedure.

1. Loosen the screw¹² on suction pipe cover¹¹.
2. Move the cover¹¹ to the left completely.
3. Tighten the screw¹² on the cover¹¹ temporarily.
4. Open the front cover⁴².
5. Open the side cover⁴¹.
6. Loosen the screw³⁸ on the collar³⁷.
(See item one of page 36.)
7. With the allen wrench in the one of screws³⁸ on the cover³⁷, set the projection of collar³⁷ on the groove of adjusting lever³⁹ leaving no space between them.
8. Tighten the screws³⁸ on the collar³⁷.
9. Rotate the handwheel manually to lower the upper knife²⁰. With its dead point, ensure the tip of upper knife blade²⁰ is 0.5 mm above the top surface of lower knife²².

7. Adjustment of knife system



WARNING

ALWAYS turn OFF the motor switch and check that the motor stops before the work.

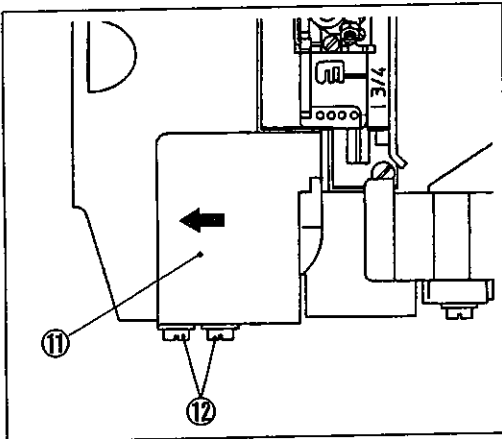

10. Check if the pressure of upper knife is proper or not by loading a thread between the upper knife²⁰ and the lower knife²² and rotating the handwheel manually.
11. Close the side cover⁴¹.
12. Loosen the screw¹² tightened on suction pipe cover temporarily.
13. Make the right side surface of the cover¹¹ and the inlet of suction pipe(front)⁹ in one line.
14. Tighten the screw¹² on the cover¹¹.

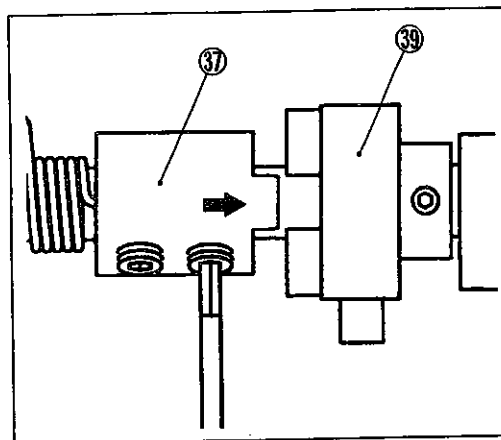
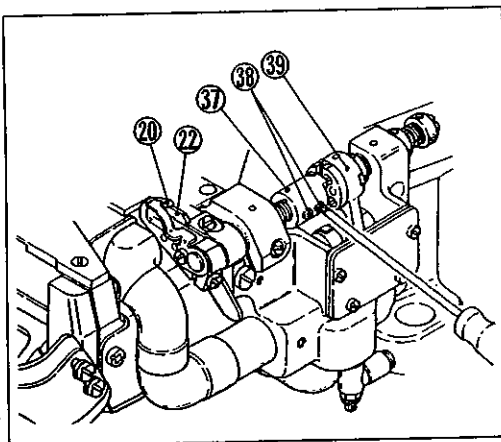
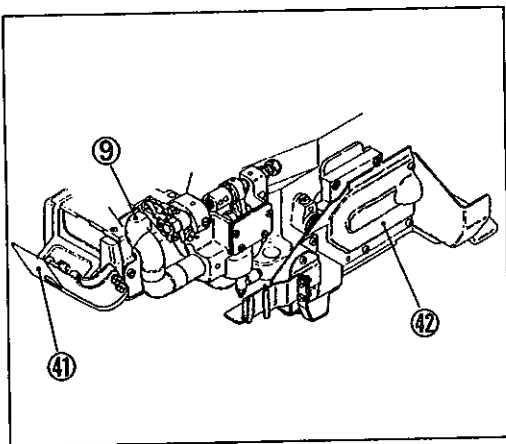

8 . Specifications

Model	VG3721
Description	High Speed Cylinder Bed 3-Needle Chainstitch Machine With Left Hand Knife Trimming Mechanism(With Cancellation)
Dimensions	470 mm (L) × 220 mm (W) × 405 mm (H)
Circumference of Cylinder Bed	340 mm
Weight	41.5 kg
Stitch Type	ISO 406, 407, 602, 605
Application	Hemming bottom on light weight knitted fabric
Sewing Speed	max. 5500 s.p.m. (during intermittent operation)
Stitch Length	1.4 - 3.6 mm number of stitch per inch: 7 - 18 number of stitch per 30 mm: 8 - 21
Needle System	UY×128GAS No. 70 - No. 90 (standard: No. 70)
Needle Distance	3 needles: 4.8 mm, 5.6 mm, 6.4 mm (2 needles: 3.2 mm, 4.0 mm)
Needle Stroke	31 mm
Upper Knife Stroke	3.0 mm - 4.0 mm
Suction of Chips	By compressed air or vacuum system
Presser Foot Lift	for needle distance 5.6 mm; with spreader: 5.5 mm with no spreader: 7.0 mm
Feed Regulation	by adjusting screw (micro adjustment available)
Differential Ratio	1 : 0.9 - 1 : 1.4 (standard) 1 : 0.9 - 1 : 1.8 (stitch length 2.5 mm or less in max. normal differential ratio) 1 : 0.6 - 1 : 1.1 (available by changing the position of link)
Differential Feed Regulation	available by adjuster (micro adjustment available) (Adjustment during operation from outside is possible by moving lever up and down.)
Lubrication	Automatic lubrication by trochoid pump
Lubrication Oil	YAMATO SF OIL No.28
Capacity of Oil Reservoir	800 cc
Installation	Table top type Semi-submerged type

Yamato

ヤマトマシン製造株式会社

YAMATO SEWING MACHINE MFG. CO., LTD.

4-4-12, NISHITENMA, KITA-KU, OSAKA, JAPAN
TEL: 81-6-6364-1321 FAX: 81-6-6364-1307

〒530-0047 大阪市北区西天満4丁目4番12号
TEL (06)6364-1321(代)
FAX (06)6365-5176

INSTRUCTIONS

UT-A, UT

UT-A44, UT-A44/ST2-A, UT-A44/CS
UT-A44/ST2-A/CS, UT-A42, UT-A42/CS
UT-2, UT-4, UT-4/ST2

VG3721

PNEUMATIC UNDER THREAD TRIMMING DEVICE

PNEUMATIC TOP COVER THREAD TRIMMING DEVICE

ELECTRIC UNDER THREAD TRIMMING DEVICE

ELECTRIC TOP COVER THREAD TRIMMING DEVICE

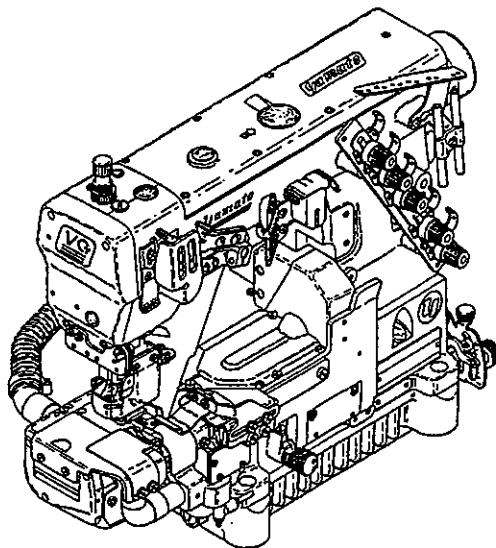

SAVE ALL INSTRUCTION MANUALS.

READ and UNDERSTAND THOROUGHLY to OPERATE for SAFE USE.

 **YAMATO SEWING MACHINE MFG. CO., LTD.**

UT-A device

pr
f

Contents

UT-A device

Chapter I. Operation	1
1-1 Operating procedure for UT-A44 device	1
1-2 Operating procedure for UT-A44/ST2-A device	2
1-3 Operating procedure for UT-A44/CS device	3
1-4 Operating procedure for UT-A44/ST2-A/CS device	4
1-5 Operating procedure for UT-A42 device	5
1-6 Operating procedure for UT-A42/CS device	6
Chapter II. Wiring	7
2-1 Detector switch	7
2-1-1 Adjusting detector switch	7
2-1-2 Connecting detector switch	7
2-2 Connecting solenoid valve	8
2-2-1 For using UT-A44, UT-A44/ST2-A (4 solenoid valves)	8
2-2-2 For using UT-A44/CS (5 solenoid valves)	9
2-2-3 For using UT-A44/ST2-A/CS (5 solenoid valves)	10
2-2-4 For using UT-A42 (3 solenoid valves)	11
2-2-5 For using UT-A42/CS (4 solenoid valves)	12
2-3 Connecting intermediate cable	13
Chapter III. Air piping diagram	14
3-1 UT-A44 device	14
3-2 UT-A44/ST2-A device	15
3-3 UT-A44/CS device	16
3-4 UT-A44/ST2-A/CS device	17
3-5 UT-A42 device	18
3-6 UT-A42/CS device	19
Chapter IV. Installation of synchronizer	20

UT-A device

Chapter V.	Adjustment of thread trimming mechanism	21
5-1	Adjusting trimming air cylinder	21
5-2	Position of lower knife	21
5-3	Relation between upper knife and lower knife	21
5-4	Position of thread clamp spring and thread clamp spring pressure	22
5-5	Pressure of thread clamp spring	22
5-6	Position of upper knife carrier	23
5-7	Relation between lower knife and needle	24
5-8	Position of lower knife point	25
5-9	Adjusting lower knife carrier guide	26
5-10	Adjusting lower knife carrier guide(upper)	27
5-11	Relation between needle thread, looper thread and lower knife	28
Chapter VI.	Adjustment of tension release mechanism	29
6-1	Tension release block	29
6-2	Tension release connecting plate	29
6-3	Thread pull-off lever	29
6-4	Tension disc separator	30
6-5	Thread pull-off hook unit	31
Chapter VII.	Adjustment of air wiper	32
Chapter VIII.	Presser foot lifter mechanism	33
Chapter IX.	ST2-A device	34
9-1	Position of movable trimming knife	34
9-2	Engagement between movable trimming knife and fixed trimming knife	35
9-3	Pressure of thread clamp spring	36
9-4	Adjusting thread pull-off hook unit	36

Chapter I . Operation

NOTE

Be sure to place fabric under the presser foot when operating this device.

1-1. Operating procedure for UT-A44 device

The needle position during stopping ; 1 position or 2 position can be selected. Please refer to instruction manuals of motor for the way to switch positions (1 position \longleftrightarrow 2 position).

The operating procedure for 1 position and 2 position is mentioned below.

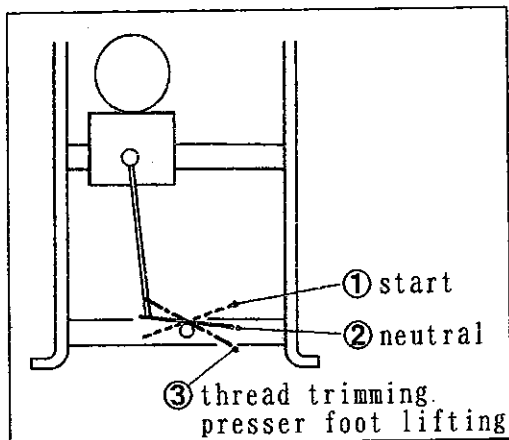

- (1) Heel back the pedal to the position③ to lift the presser foot.
- (2) Load the fabric under the presser foot and press down the pedal to the position①.
➡ Machine starts sewing and suction of chips is activated synchronously.
- (3) Release the pedal to the neutral②.
➡ Suction of chips is deactivated.
➡ The needle stops at its bottom.
(When 1 position is selected, this item is skipped.)
- (4) Heel back the pedal to the position③.
➡ The needle rises and stops at its top. The trimming knife mechanism is activated to cut needle thread and looper thread under the stitch plate. The looper thread is held by the thread clamp spring. And then, the presser foot rises and the air wiper blows air.
- (5) Release the pedal to the neutral②.
➡ The presser foot lowers.

NOTE

The presser foot can be lifted or lowered by heeling back the pedal to the positions② and ③ until the pedal is pressed down to the position①.

Chapter I . Operation

NOTE

Be sure to place fabric under the presser foot when operating this device.

1-2 Operating procedure for UT-A44/ST2-A device

The needle position during stopping ; 1 position or 2 position can be selected.

Please refer to instruction manuals of motor for the way to switch positions

(1 position ↔ 2 position).

The operating procedure for 1 position and 2 position is mentioned below.

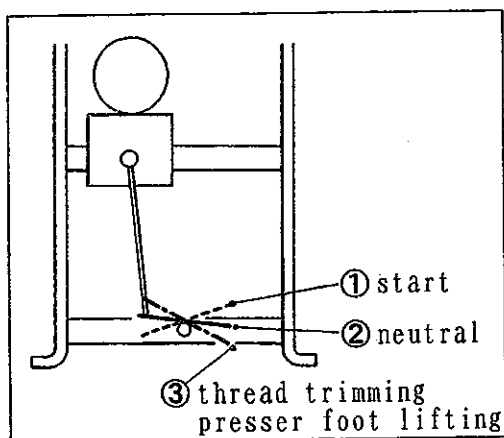

- (1) Heel back the pedal to the position③ to lift the presser foot.
- (2) Load the fabric under the presser foot and press down the pedal to the position①.
 - ➔ Machine starts sewing and suction of chips is activated synchronously.
- (3) Release the pedal to the neutral②.
 - ➔ Suction of chips is deactivated.
 - ➔ The needle stops at its bottom.
(When 1 position is selected, this item is skipped.)
- (4) Heel back the pedal to the position③.
 - ➔ The needle rises and stops at its top. The trimming knife mechanism is activated to cut needle thread and looper thread under the stitch plate. The looper thread is held by the thread clamp spring. The ST2-A device cuts and holds top cover thread. And then, the presser foot rises.
- (5) Release the pedal to the neutral②.
 - ➔ The presser foot lowers.

NOTE

The presser foot can be lifted or lowered by heeling back the pedal to the positions② and ③ until the pedal is pressed down to the position①.

Chapter I . Operation

NOTE

Be sure to place fabric under the presser foot when operating this device.

1-3 Operating procedure for UT-A44/CS device

The needle position during stopping ; 1 position or 2 position can be selected.
Please refer to instruction manuals of motor for the way to switch positions
(1 position \longleftrightarrow 2 position).

The operating procedure for 1 position and 2 position is mentioned below.

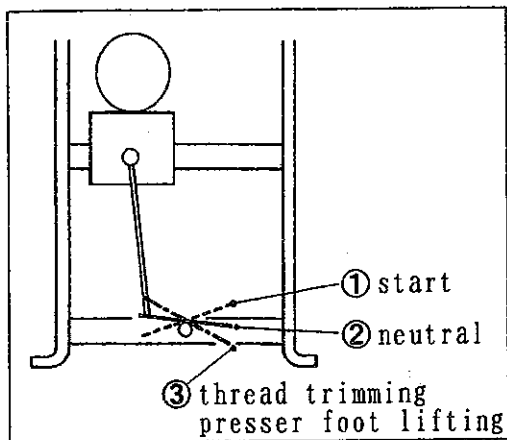

- (1) Heel back the pedal to the position③ to lift the presser foot.
- (2) Load the fabric under the presser foot and press down the pedal to the position①.
➡ Machine starts sewing and suction of chips is activated synchronously.
- (3) Release the pedal to the neutral②.
➡ Suction of chips is deactivated.
➡ The needle stops at its bottom.
(When 1 position is selected, this item is skipped.)
- (4) Heel back the pedal to the position③.
➡ The CS device is activated.
The needle rises and stops at its top.
The trimming knife mechanism is activated to cut needle thread and looper thread under the stitch plate.
The looper thread is held by the thread clamp spring. And then, the presser foot rises and the air wiper blows air.
- (5) Release the pedal to the neutral②.
➡ The presser foot lowers.

NOTE

The presser foot can be lifted or lowered by heeling back the pedal to the positions② and ③ until the pedal is pressed down to the position①.

Chapter I . Operation

⚠ NOTE

Be sure to place fabric under the presser foot when operating this device.

1-4 Operating procedure for UT-A44/ST2-A/CS device

The needle position during stopping ; 1 position or 2 position can be selected.

Please refer to instruction manuals of motor for the way to switch positions

(1 position ↔ 2 position).

The operating procedure for 1 position and 2 position is mentioned below.

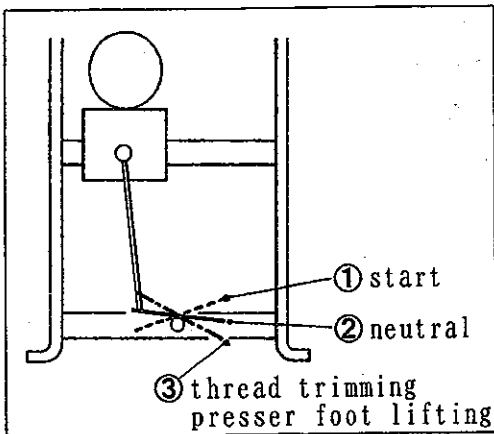

- (1) Heel back the pedal to the position③ to lift the presser foot.
- (2) Load the fabric under the presser foot and press down the pedal to the position①.
➡ Machine starts sewing and suction of chips is activated synchronously.
- (3) Release the pedal to the neutral②.
➡ Suction of chips is deactivated.
➡ The needle stops at its bottom.
(When 1 position is selected, this item is skipped.)
- (4) Heel back the pedal to the position③.
➡ The CS device is activated.
The needle rises and stops at its top.
The trimming knife mechanism is activated to cut needle thread and looper thread under the stitch plate.
The looper thread is held by the thread clamp spring. The ST2-A device cuts a holds top cover thread. And then, the presser foot rises.
- (5) Release the pedal to the neutral②.
➡ The presser foot lowers.

NOTE

The presser foot can be lifted or lowered by heeling back the pedal to the positions② and ③ until the pedal is pressed down to the position①.

Chapter I . Operation

NOTE

Be sure to place fabric under the presser foot when operating this device.

1-5 Operating procedure for UT-A42 device

The needle position during stopping ; 1 position or 2 position can be selected.
Please refer to instruction manuals of motor for the way to switch positions
(1 position \longleftrightarrow 2 position).

The operating procedure for 1 position and 2 position is mentioned below.

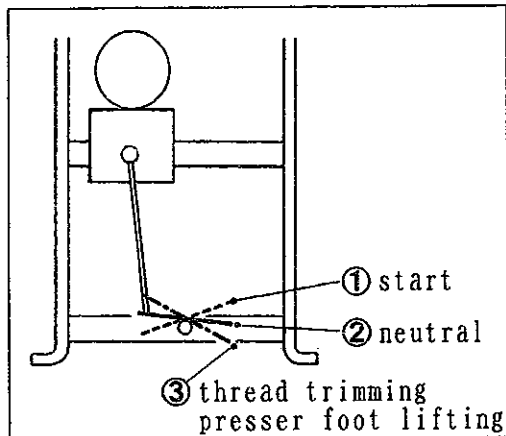

- (1) Heel back the pedal to the position③ to lift the presser foot.
- (2) Load the fabric under the presser foot and press down the pedal to the position①.
➡ Machine starts sewing and suction of chips is activated synchronously.
- (3) Release the pedal to the neutral②.
➡ Suction of chips is deactivated.
➡ The needle stops at its bottom.
(When 1 position is selected, this item is skipped.)
- (4) Heel back the pedal to the position③.
➡ The needle rises and stops at its top.
The trimming knife mechanism is activated to cut needle thread and looper thread under the stitch plate.
The looper thread is held by the thread clamp spring. The presser foot rises and the air wiper blows air.
- (5) Release the pedal to the neutral②.
➡ The presser foot lowers.

NOTE

The presser foot can be lifted or lowered by heeling back the pedal to the positions② and ③ until the pedal is pressed down to the position①.
While the presser foot is at its top, the air wiper blows air.

Chapter 1 . Operation

NOTE

Be sure to place fabric under the presser foot when operating this device.

1-6 Operating procedure for UT-A42/CS device

The needle position during stopping; 1 position or 2 position can be selected.

Please refer to instruction manuals of motor for the way to switch positions

(1 position \longleftrightarrow 2 position).

The operating procedure for 1 position and 2 position is mentioned below.

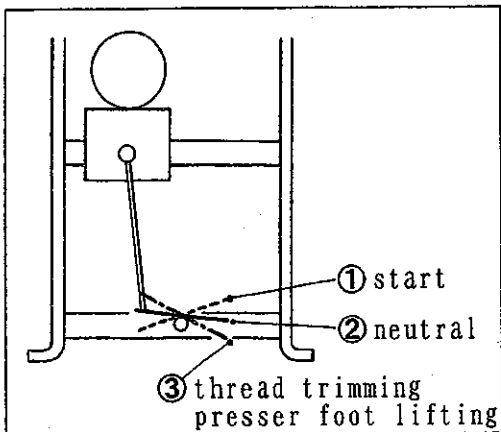

- (1) Heel back the pedal to the position③ to lift the presser foot.
- (2) Load the fabric under the presser foot and press down the pedal to the position①.
➔ Machine starts sewing and suction of chips is activated synchronously.
- (3) Release the pedal to the neutral②.
➔ Suction of chips is deactivated.
➔ The needle stops at its bottom.
(When 1 position is selected, this item is skipped.)
- (4) Heel back the pedal to the position③.
➔ The CS device is activated.
The needle rises and stops at its top.
The trimming knife mechanism is activated to cut needle thread and looper thread under the stitch plate.
The looper thread is held by the thread clamp spring. And then, the presser foot rises and the air wiper blows air.
- (5) Release the pedal to the neutral②.
➔ The presser foot lowers.

NOTE

The presser foot can be lifted or lowered by heeling back the pedal to the positions② and ③ until the pedal is pressed down to the position①.

While the presser foot is at its top, the air wiper blows air.

Chapter II . Wiring

2-1 Detector switch

2-1-1 Adjusting detector switch

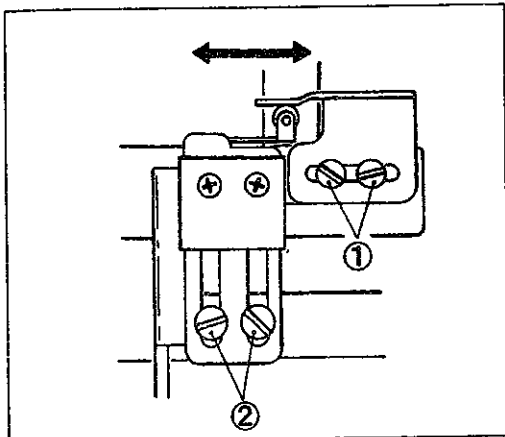

The detector switch is equipped not to run the machine until the trimming knife returns.

For adjustment:

- (1) Loosen the screws ① and ②.
- (2) Adjust so that the switch is turned ON when the trimming knife returns to the original position.
- (3) Tighten the screws ① and ②.

2-1-2 Connecting detector switch

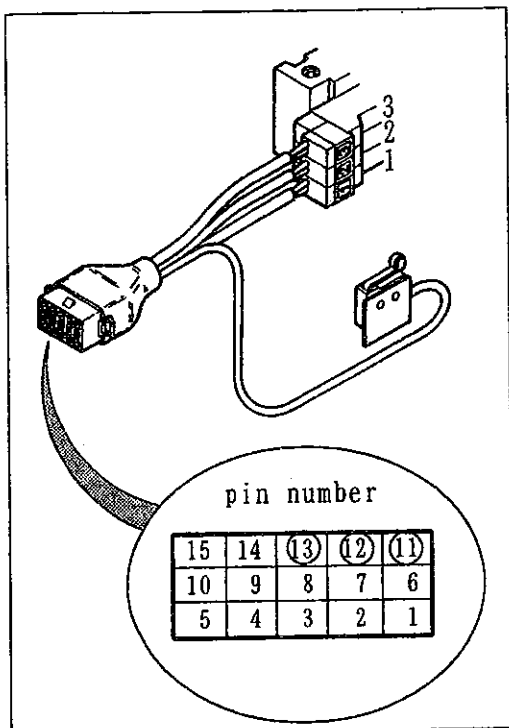

Connect the cords of the detector switch to the following numbers in the 15P-connector.

- black cord: ⑪
- white cord: ⑬
- red cord: ⑫

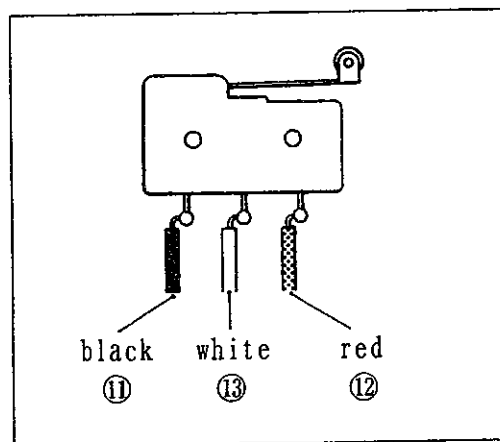

Chapter II . Wiring

2-2 Connecting solenoid valve

2-2-1 For using UT-A44, UT-A44/ST2-A (4 solenoid valves)

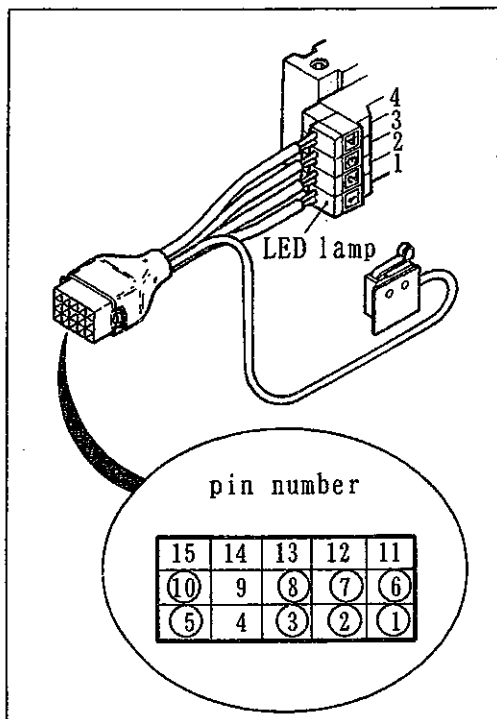

The LED lamp for the solenoid valve goes on (red) when each mechanism operates. If the LED lamps for the solenoid valves 1, 2, 3 and 4 do not go on (red), check wiring.

Connect the cords from the solenoid valves to the following numbers in the 15P-connector.

solenoid valve no.	15P-connector no.	Use for solenoid valve
1	① ⑥	presser foot lifting
2	② ⑦	thread trimming
3	③ ⑧	top cover thread trimming and air wiper
4	⑤ ⑩	suction of chips

NOTE

The part no. of the solenoid valve, complete set is 1090224.

Chapter II . Wiring

2-2-2 For using UT-A44/CS (5 solenoid valves)

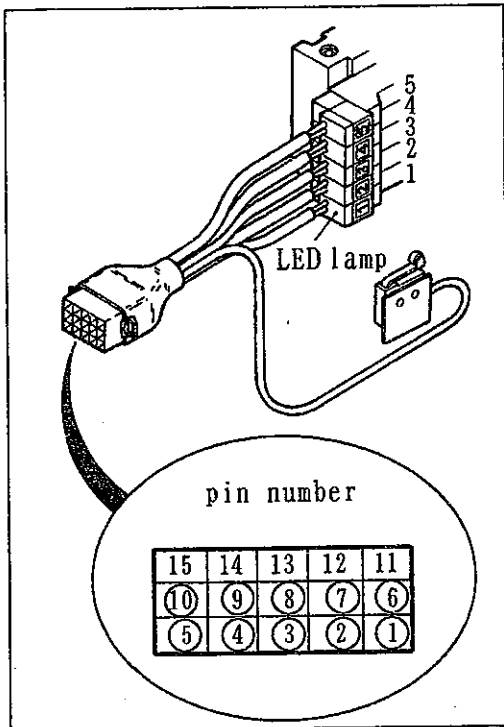

The LED lamp for the solenoid valve goes on (red) when each mechanism operates. If the LED lamps for the solenoid valves 1, 2, 3, 4, and 5 do not go on (red), check wiring.

Connect the cords from the solenoid valves to the following numbers in the 15P-connector.

solenoid valve no.	15P-connector no.	Use for solenoid valve
1	① ⑥	presser foot lifting
2	② ⑦	thread trimming
3	③ ⑧	air wiper
4	⑤ ⑩	suction of chips
5	④ ⑨	CS

NOTE

The part no. of the solenoid valve, complete set is 1090230.

Chapter II . Wiring

2-2-3 For using UT-A44/ST2-A/CS (5 solenoid valves)

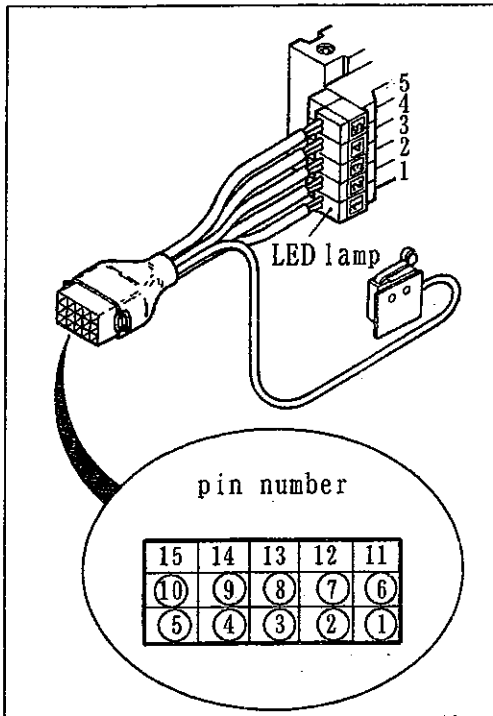

The LED lamp for the solenoid valve goes on (red) when each mechanism operates. If the LED lamps for the solenoid valves 1, 2, 3, 4, and 5 do not go on (red), check wiring.

Connect the cords from the solenoid valves to the following numbers in the 15P-connector.

solenoid valve no.	15P-connector no.	Use for solenoid valve
1	① ⑥	presser foot lifting
2	② ⑦	thread trimming
3	③ ⑧	top cover thread trimming
4	⑤ ⑩	suction of chips
5	④ ⑨	CS

NOTE

The part no. of the solenoid valve, complete set is 1090231.

Chapter II . Wiring

2-2-4 For using UT-A42 (3 solenoid valves)

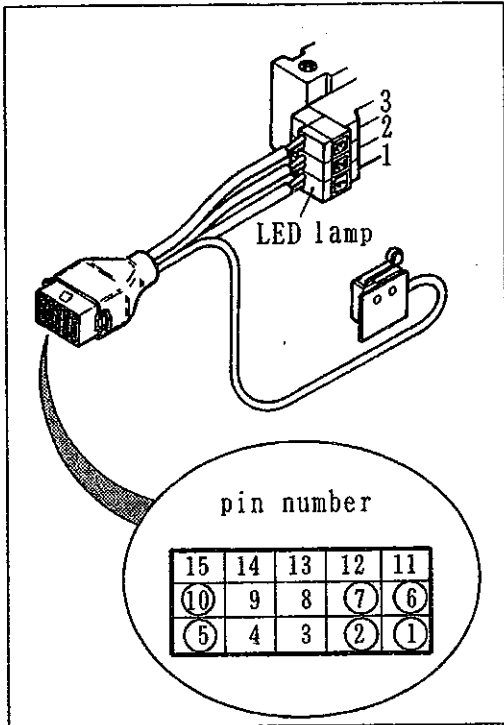

The LED lamp for the solenoid valve goes on (red) when each mechanism operates. If the LED lamps for the solenoid valves 1, 2 and 3 do not go on (red), check wiring.

Connect the cords from the solenoid valves to the following numbers in the 15P-connector.

solenoid valve no.	15P-connector no.	Use for solenoid valve
1	① ⑥	presser foot lifting and air wiper
2	② ⑦	thread trimming
3	⑤ ⑩	suction of chips

NOTE

The part no. of the solenoid valve, complete set is 1090219.

Chapter II . Wiring

2-2-5 For using UT-A42/CS (4 solenoid valves)

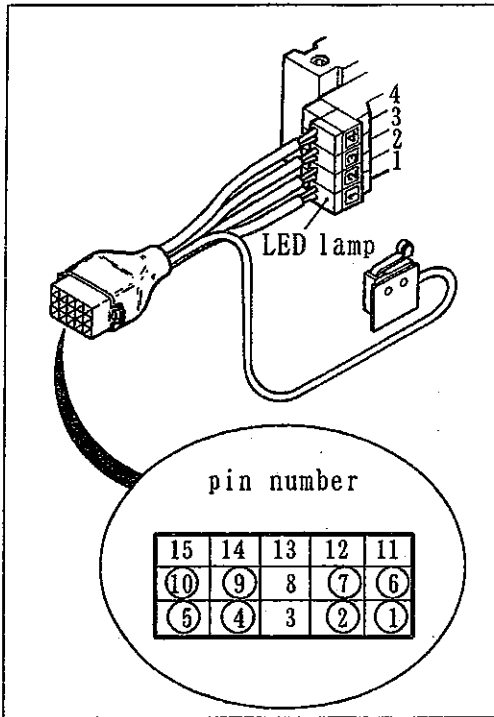

The LED lamp for the solenoid valve goes on (red) when each mechanism operates. If the LED lamps for the solenoid valves 1, 2, 3 and 4 do not go on (red), check wiring.

Connect the cords from the solenoid valves to the following numbers in the 15P-connector.

solenoid valve no.	15P-connector no.	Use for solenoid valve
1	① ⑥	presser foot lifting and air wiper
2	② ⑦	thread trimming
3	⑤ ⑩	suction of chips
4	④ ⑨	CS

NOTE

The part no. of the solenoid valve, complete set is 1090222.

11 Black
12 Red
13 white

Chapter II . Wiring

2-3 Connecting intermediate cable

Connect the intermediate cable to the connector from the solenoid valve and to the control box for the motor.

NOTES

- (1) The figure shows three solenoid valves.
- (2) The intermediate cable depends on your motor.

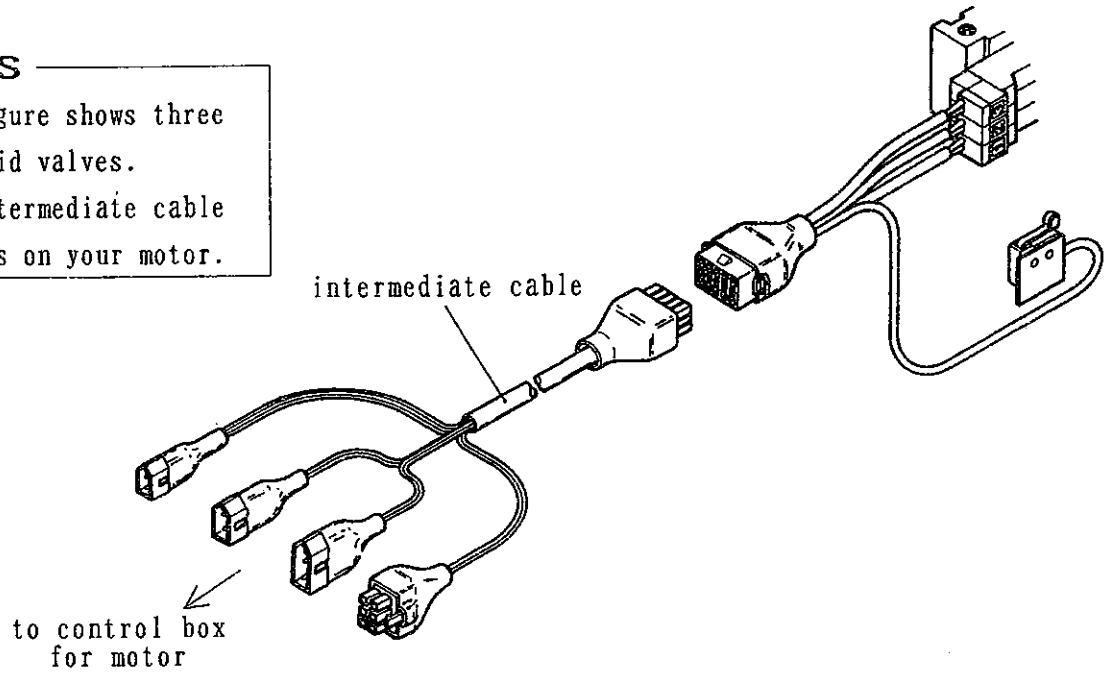

Chapter III . Air piping diagram

3-2 UT-A44/ST2-A device

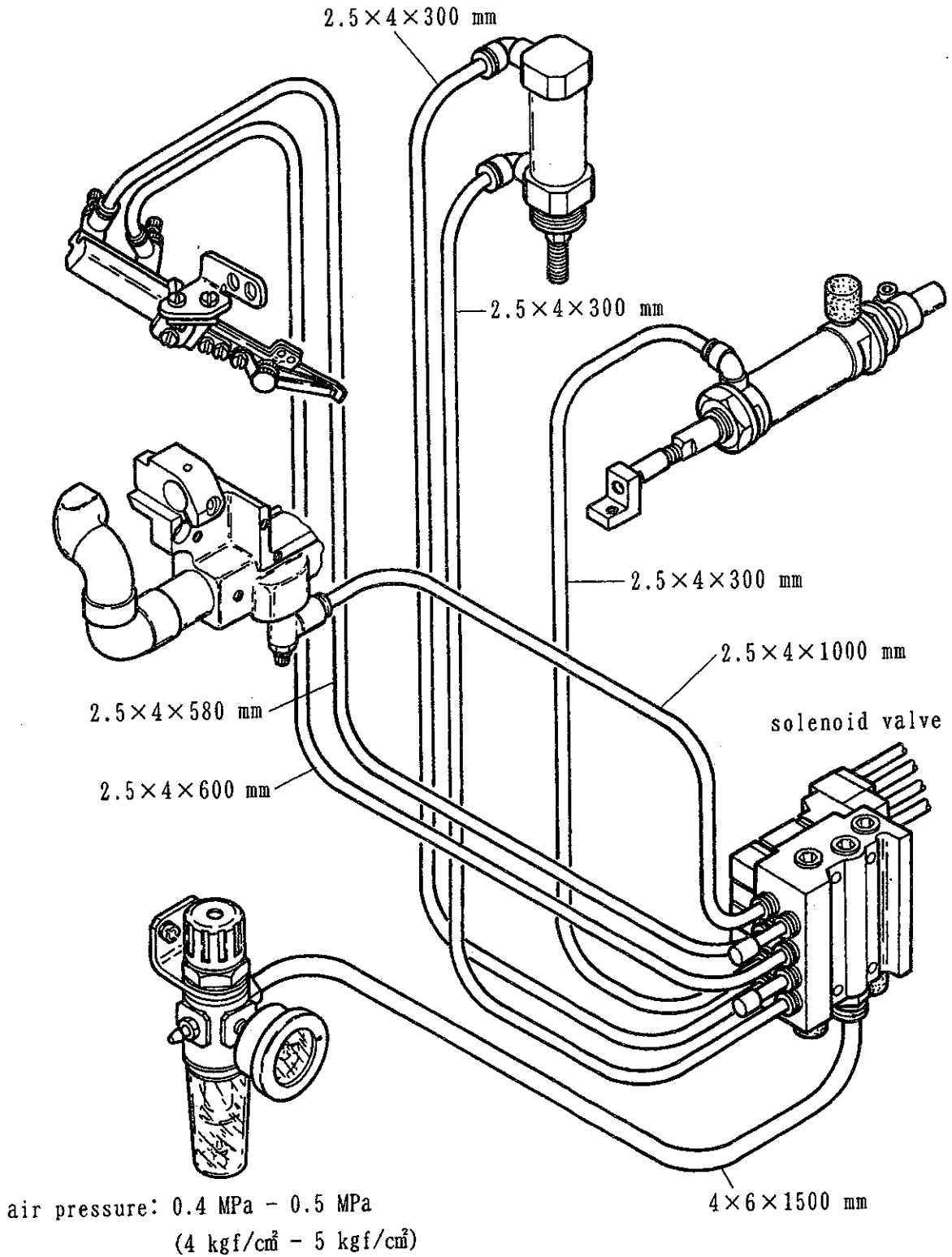

Chapter III . Air piping diagram

3-3 UT-A44/CS device

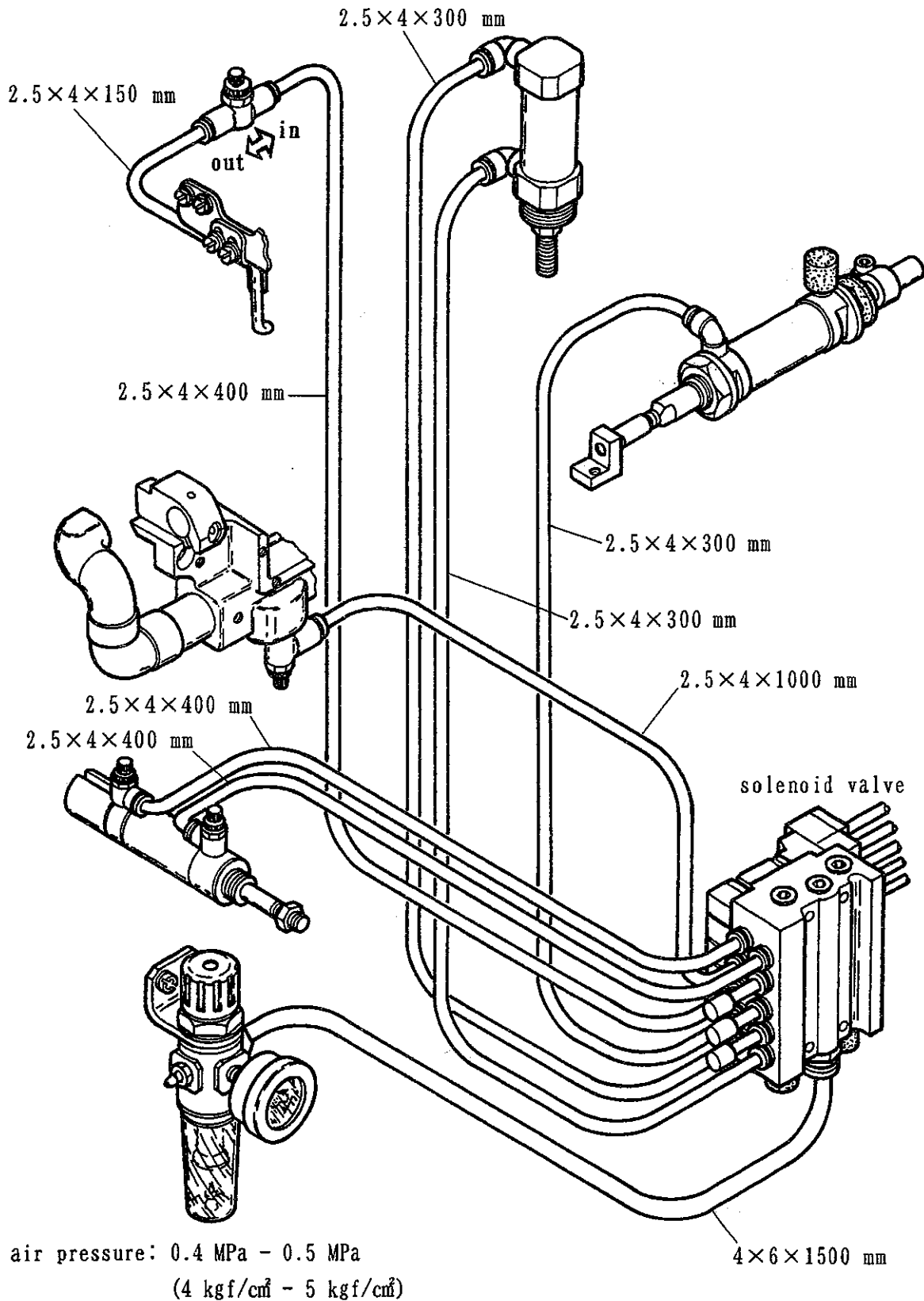

Chapter III . Air piping diagram

3-4 UT-A44/ST2-A/CS device

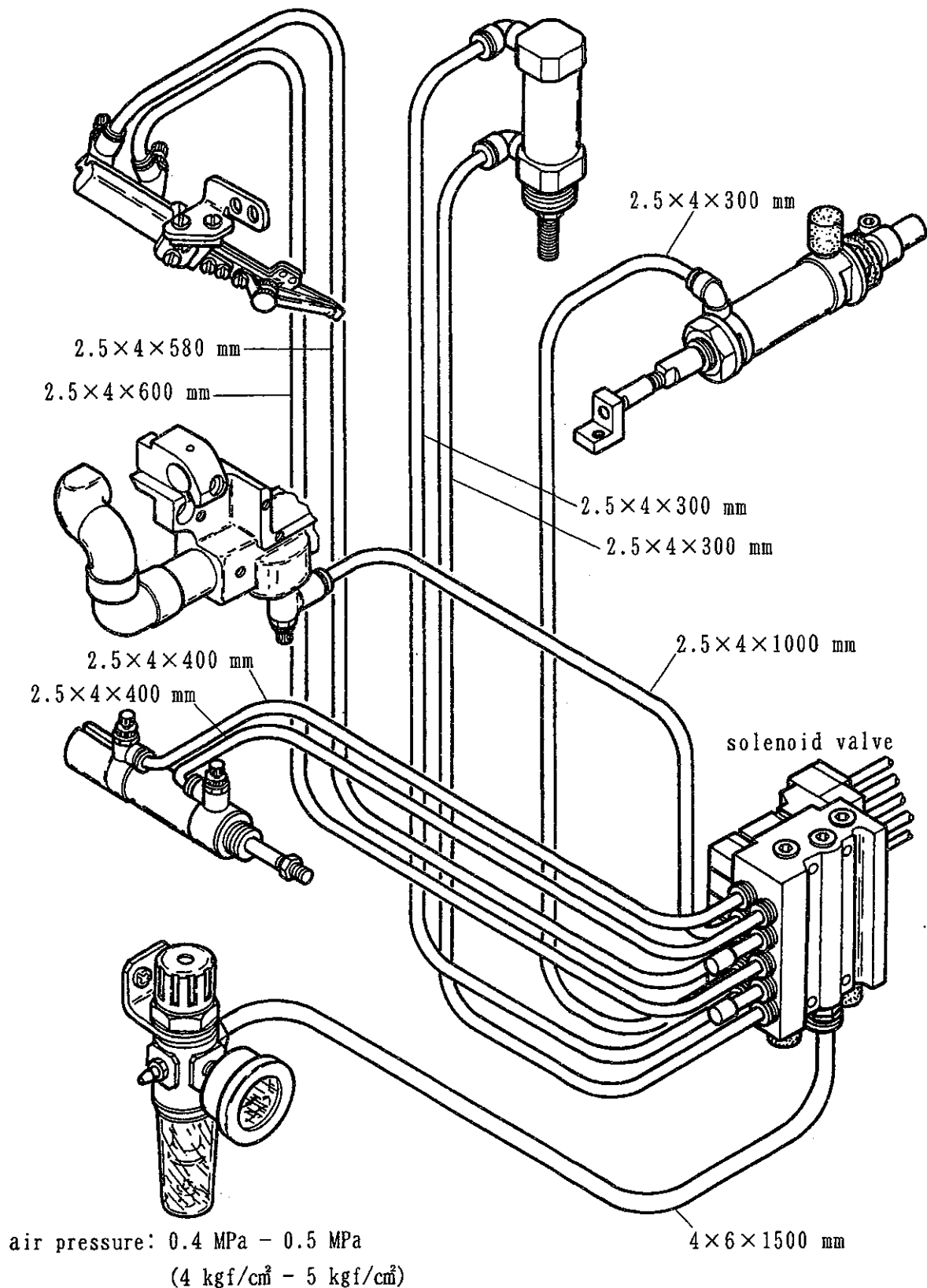

Chapter III . Air piping diagram

3-5 UT-A42 device

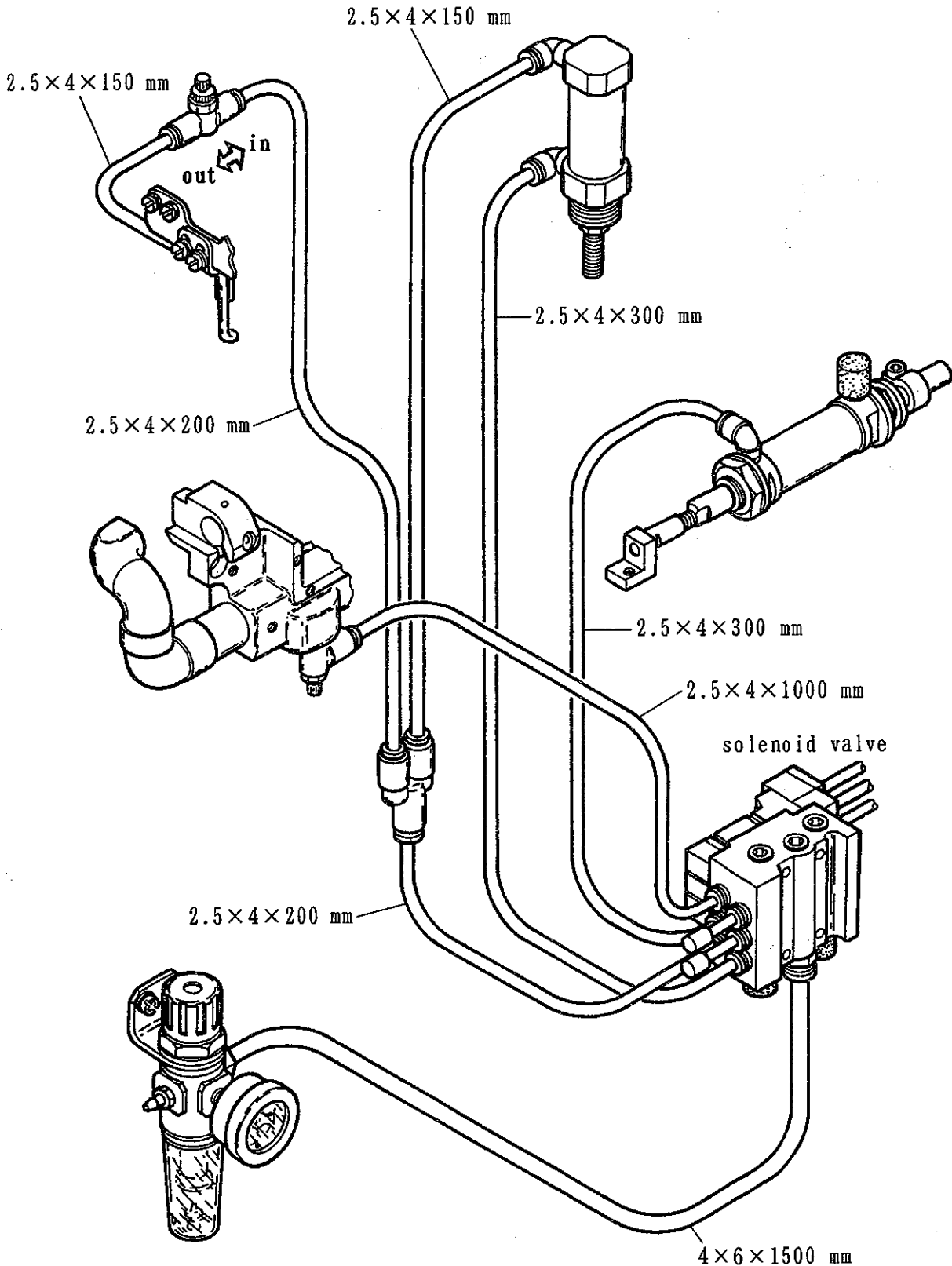

air pressure: 0.4 MPa - 0.5 MPa
(4 kgf/cm² - 5 kgf/cm²)

Chapter III . Air piping diagram

3-6 UT-A42/CS device

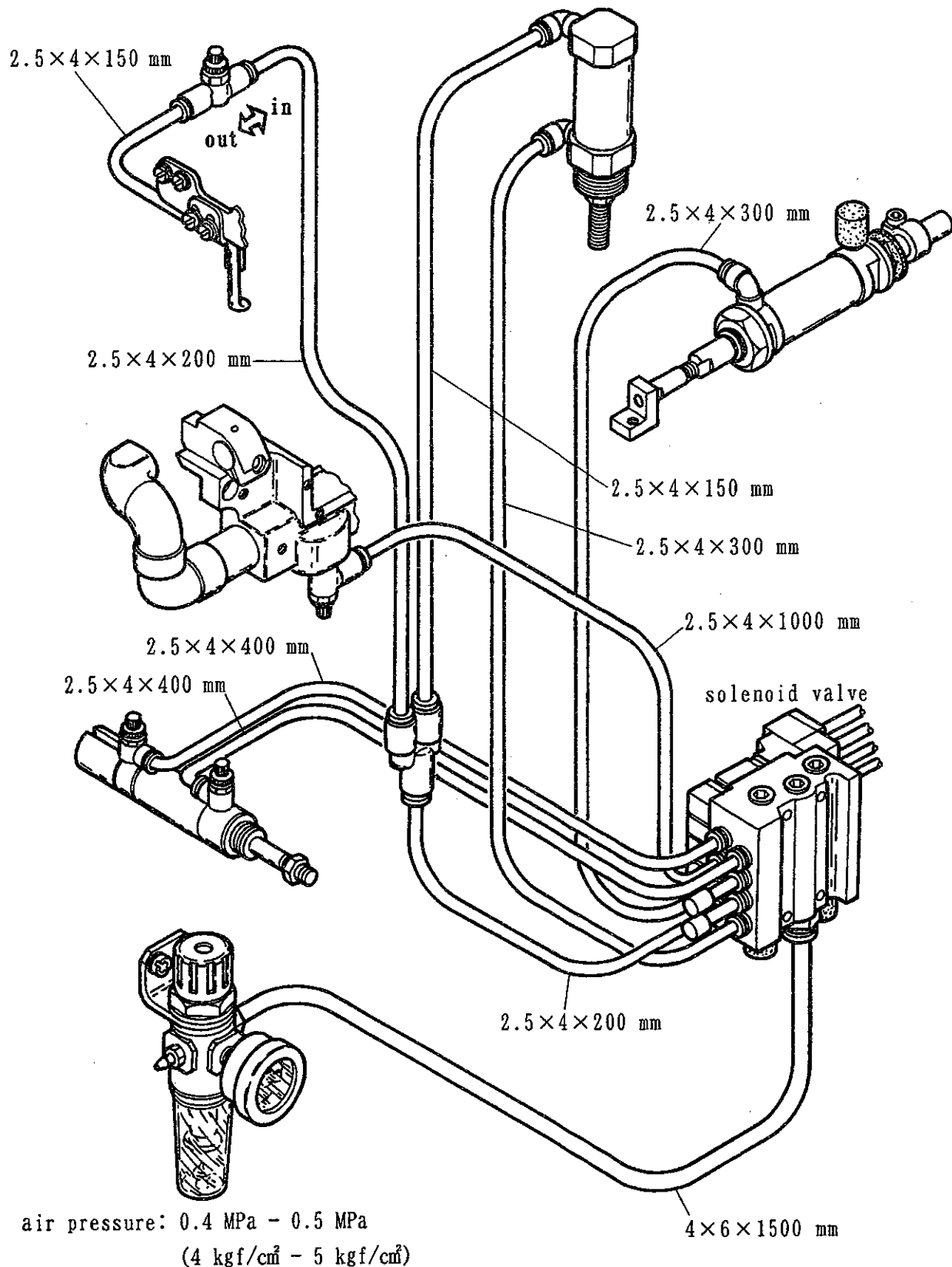

Chapter IV . Installation of synchronizer

CAUTION

Remove the plug for the trimming air cylinder from the control box for the motor.
The parts may be contacted and broken.

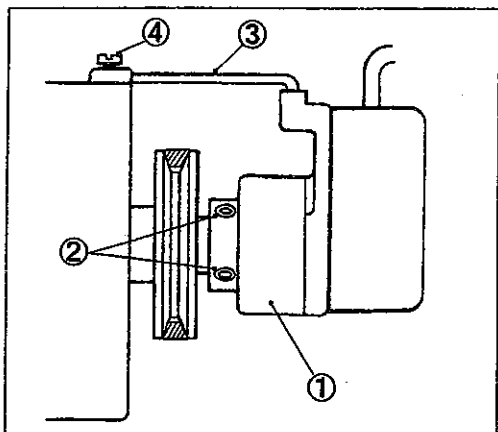

- (1) Install the synchronizer① on the machine pulley and tighten the screws② lightly.
- (2) Insert the positioning pin③ in the groove of the synchronizer① and tighten the screw④.
- (3) Turn ON the motor switch.
- (4) Press down the pedal to sew two or three stitches.

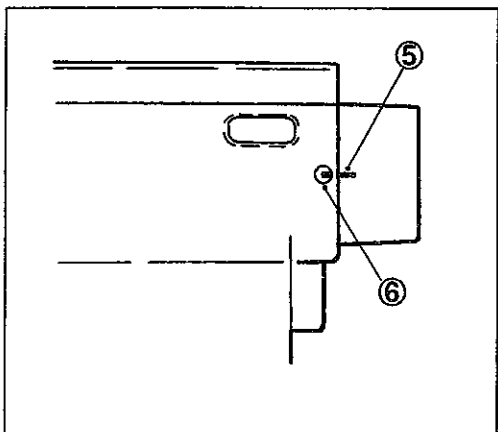

- (5) Heel back the pedal and the needle stops at a certain position.
- (6) Loosen the screws② and turn the pulley clockwise to align the line⑤ on the handwheel with the hole⑥ in the machine arm, taking care not to shift the position of the screws②.

NOTES

- (1) The needle bar is at the top of its travel.
- (2) This device is in good condition when the needle bar is at the position from the top to 0.5 mm below by further turning the pulley.
- (7) Press down the pedal to run the machine for a few stitches to check that the needle bar stops at the position from the top to 0.5 mm below.

WARNING

ALWAYS turn OFF the motor switch and check that the motor stops before adjustment.

5-1 Adjusting trimming air cylinder

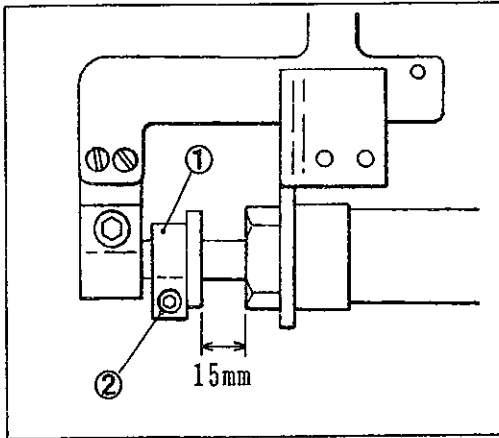

The proper stroke is 15 mm.

For adjustment, loosen the screw② of the collar①.

NOTE

When the stroke of the air cylinder is changed, readjust the action of the thread trimming mechanism. Check that the condition of the detector switch. (See the section '2-1-1 Adjusting detector switch' on page 5.

5-2 Position of lower knife

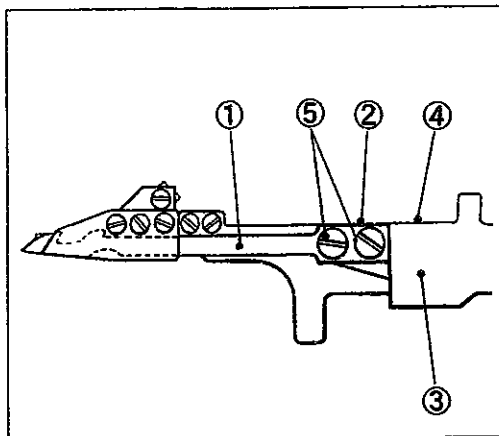

CAUTION

The trimming knife mechanism can be operated manually only when the needle is at its top. If the needles are not at the top, the parts may be contacted and broken.

- (1) Make the side② of the lower knife① parallel with the side④ of the lower knife carrier③.
- (2) Fix with the screws⑤.

5-3 Relation between upper knife and lower knife

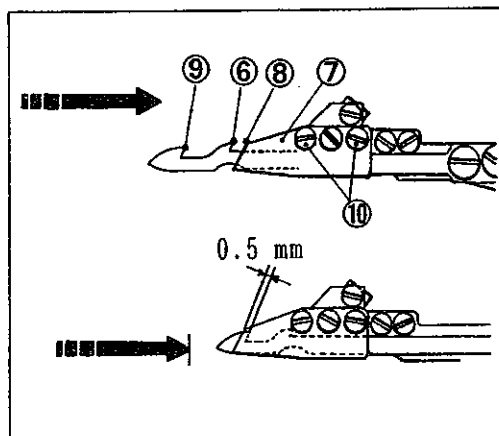

- (1) Loosen the screws⑩.
- (2) Align the hook⑥ for needle thread of the lower knife with the corner⑧ of the upper knife⑦.
- (3) When the lower knife is at the extreme right, move the upper knife⑦ right and left to make an engagement of 0.5 mm between the hook⑨ for looper thread and the upper knife⑦.
- (4) Tighten the screws⑩.

Chapter V . Adjustment of thread trimming mechanism



WARNING

ALWAYS turn OFF the motor switch and check that the motor stops before adjustment.

5-4 Position of thread clamp spring and thread clamp spring pressure

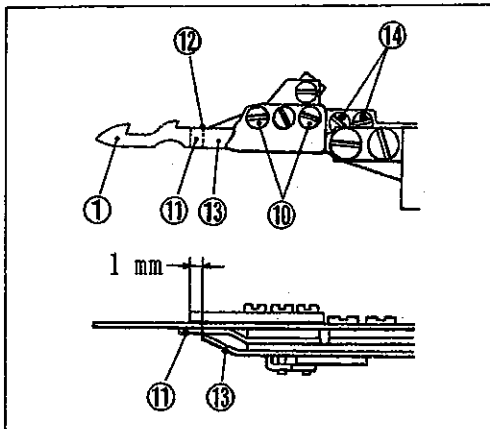

- (1) Loosen the screws⑩.
- (2) Make the side of the thread clamp spring⑪ even with the side⑫ of the lower knife①.
- (3) Tighten the screws⑩.
- (4) Loosen the screws⑭.
- (5) Make the side of the thread clamp spring pressure⑬ even with the sides of the lower knife① and the spring⑪.
- (6) Make a distance of 1.0 mm from the tip of the pressure⑬ to that of the upper knife.
- (7) Tighten the screws⑭.

5-5 Pressure of thread clamp spring

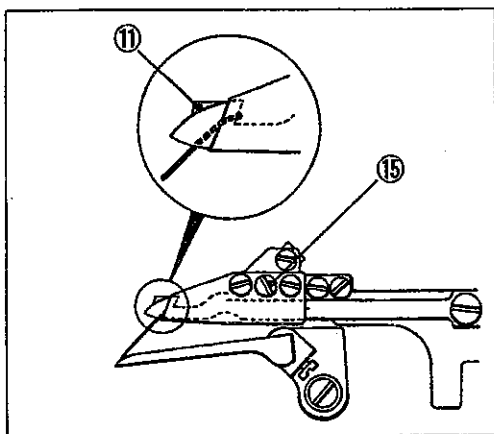

Looper thread is held by the thread clamp spring⑪ after cut.

To increase the pressure, turn the adjusting screw⑮ clockwise.

To decrease, turn the screw⑮ counterclockwise.

NOTE

The pressure should be minimized so long as looper thread can be held.



WARNING

ALWAYS turn OFF the motor switch and check that the motor stops before adjustment.

5-6 Position of upper knife carrier

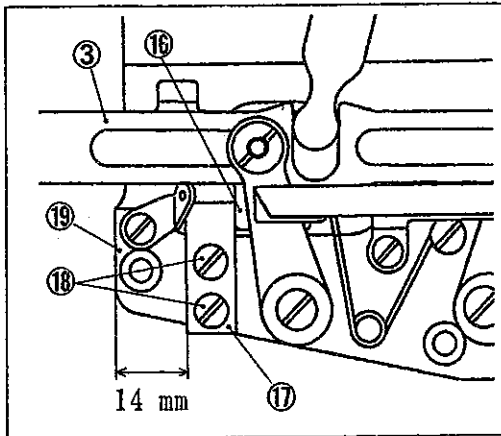

The upper knife carrier¹⁶ slides to the left simultaneously with the lower knife carrier³ and stops by touching the upper knife carrier stopper¹⁷. The upper knife slides under the stitch plate.



CAUTION

NEVER slide the carrier¹⁶ to the left too much, because the thread clamp spring pressure touches the looper.

For adjustment:

- (1) Loosen the screws¹⁸.
- (2) Make a distance of 14 mm between the left end of the crank chamber cover¹⁹ and that of the stopper¹⁷.
- (3) Tighten the screws¹⁸.

Chapter V . Adjustment of thread trimming mechanism



WARNING

ALWAYS turn OFF the motor switch and check that the motor stops before adjustment.

5-7 Relation between lower knife and needle

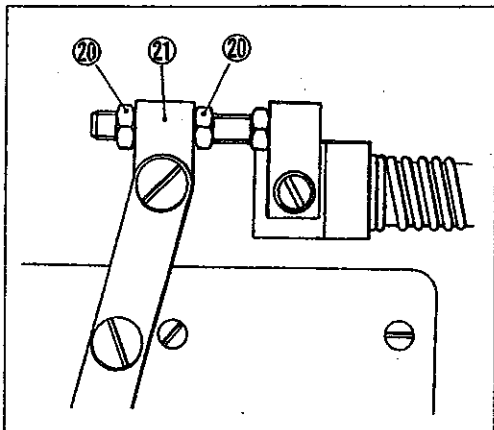

- (1) Loosen the nuts ⑳.
- (2) Move the lower knife ① to the extreme left.
- (3) Adjust the connecting block ㉑ to the right and left to make a distance of 3.5 mm - 4.5 mm from the hook ⑥ for needle thread to the left needle.
- (4) Tighten the nuts ⑳.

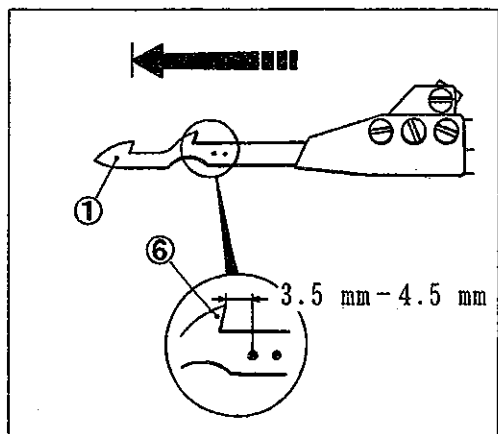



WARNING

ALWAYS turn OFF the motor switch and check that the motor stops before adjustment.

5-8 Position of lower knife point

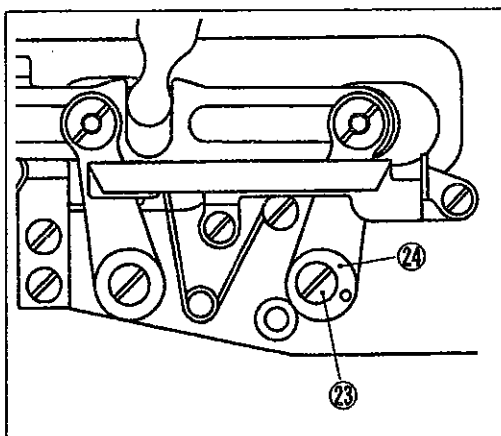
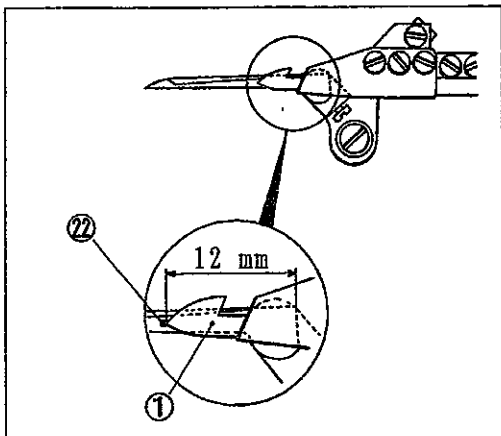

- (1) Slide the lower knife① to the left.
- (2) When the distance between the point② of the knife① and the right end of the looper is 12 mm, center the point② on the top of the looper.
- (3) To slide the point② rearward, loosen the screw②③ to turn the knife guide lever ring (right)②④ clockwise. To slide forward, turn the ring(right)②④ counterclockwise.
- (4) Tighten the screw②③.

Chapter V Adjustment of thread trimming mechanism



WARNING

ALWAYS turn OFF the motor switch and check that the motor stops before adjustment.

5-9 Adjusting lower knife carrier guide

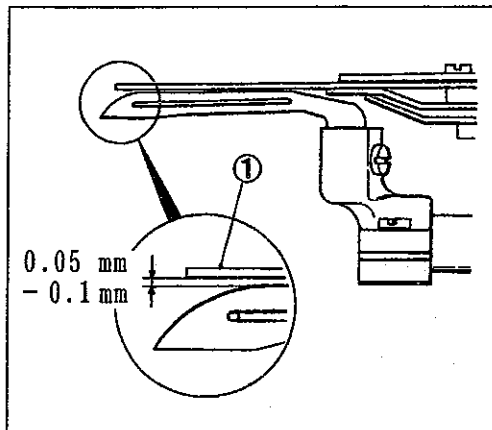

The proper distance is 0.05 mm - 0.1 mm between the lower knife① and the top of the looper.

- (1) Loosen the screw②⑤ and move the lower knife carrier guide②⑥ up and down.
- (2) Tighten the screw②⑤.
- (3) Check that the upper knife carrier and the lower knife carrier can move smoothly.

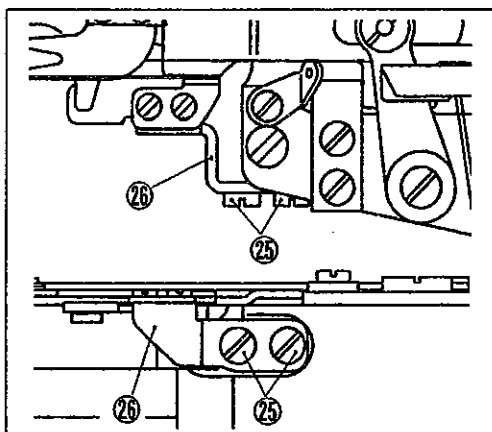

The
rem

(1)
(2)

(1)

(2)

 **WARNING**

ALWAYS turn OFF the motor switch and check that the motor stops before adjustment.

5-10 Adjusting lower knife carrier guide(upper)

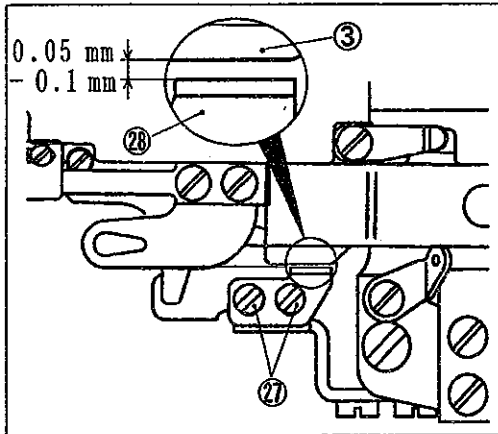

The upper knife carrier slides to the left simultaneously with the lower knife carrier and stops by touching the upper knife carrier stopper.

- (1) Loosen the screws 27.
- (2) When the upper knife carrier is stopped as mentioned above, make a distance of 0.05 mm - 0.1 mm between the lower knife carrier 3 and the lower knife carrier guide(upper) 28.
- (3) Tighten the screws 27.

Chapter V . Adjustment of thread trimming mechanism



WARNING

ALWAYS turn OFF the motor switch and check that the motor stops before adjustment.

5-11 Relation between needle thread, looper thread and lower knife

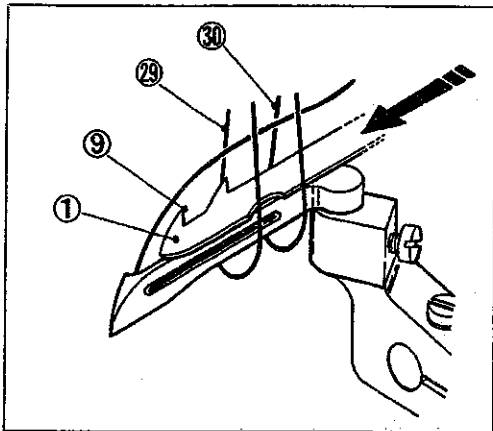

Before sewing performance, be sure to check as follows:

- The lower knife① passes through the loops②⑨ and ⑩ of needle thread.

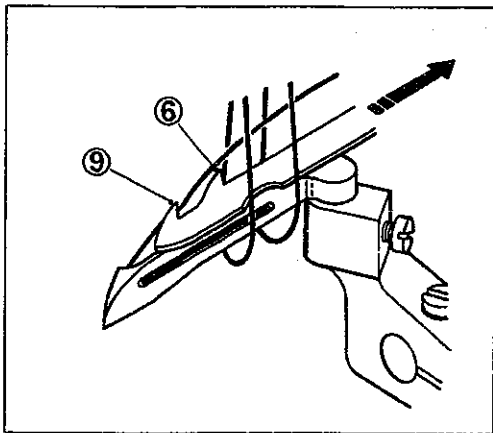

- The hook⑨ for looper thread moves in front of looper thread.
- The needle thread is pulled to the right by the hook⑥ to be cut by the upper knife.
- The looper thread is pulled to the right by the hook⑨ to be cut by the upper knife.

WARNING

ALWAYS turn OFF the motor switch and check that the motor stops before adjustment.

6-1 Tension release block

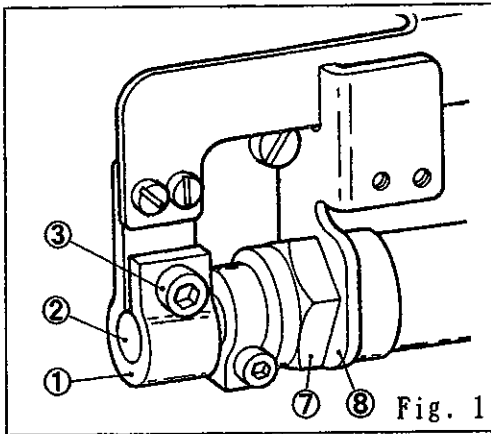

- (1) Loosen the screw③.
- (2) When the rod of the trimming air cylinder is at its extreme left (when the trimming knife mechanism does not operate), make the tension release block① even with the rod end② of the air cylinder.
- (3) Tighten the screw③.

6-2 Tension release connecting plate

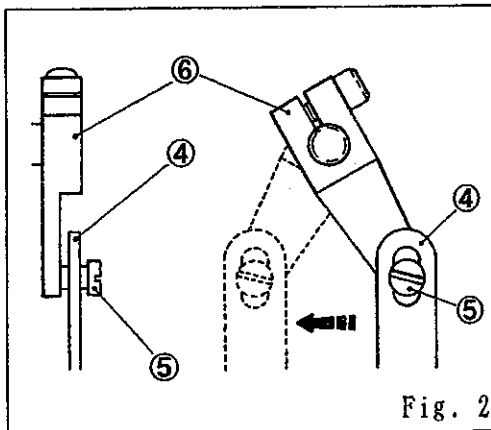

See the figures 1 and 2.

- (1) Loosen the lock nut⑦ of the trimming air cylinder.
- (2) Adjust the position of the switch holder⑧ so that the tension release connecting plate④ is in the middle of the screw head⑤ and the tension release lever⑥.
- (3) Tighten the nut⑦.

6-3 Thread pull-off lever

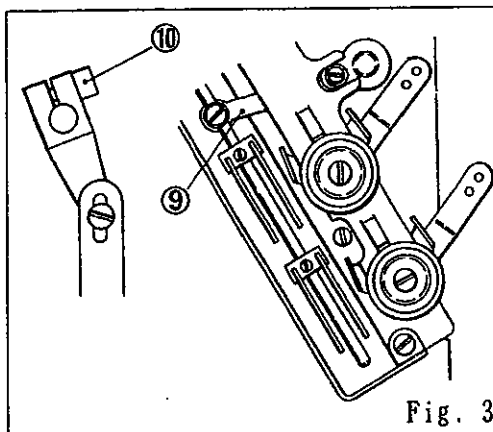

- (1) Loosen the screw⑩ of the tension release lever on the back of the machine frame unit.
- (2) Raise the thread pull-off lever⑨ to its top.
- (3) Tighten the screw⑩.

Chapter VI. Adjustment of tension release mechanism

6-4 Tension disc separator



WARNING

ALWAYS turn OFF the motor switch and check that the motor stops before adjustment.

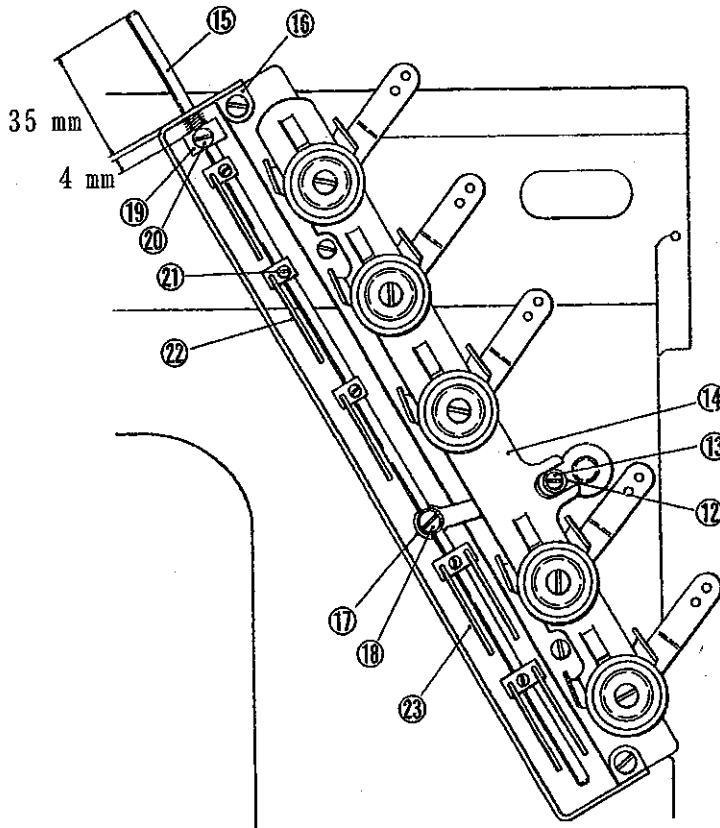

- (1) Loosen the screw¹³ of the tension release adjusting eccentric¹².
- (2) Position the tension disc separator¹⁴ by turning the eccentric¹² so that the thread tension discs can open as soon as possible. To open as soon as possible, lower the separator¹⁴.
- (3) Loosen the screw¹⁸ to make a distance of 35 mm from the top of the tension pull-off bar¹⁵ to that of the thread pull-off eyelet¹⁶.
- (4) Fix the bar¹⁵ to the thread pull-off bar holder¹⁷ with the screw¹⁸.
- (5) Loosen the screw²⁰.
- (6) Make a distance of 4.0 mm between the collar¹⁹ and the eyelet¹⁶.
- (7) Tighten the screw²⁰.

Chapter VI. Adjustment of tension release mechanism

6-5 Thread pull-off hook unit

WARNING

ALWAYS turn OFF the motor switch and check that the motor stops before adjustment.

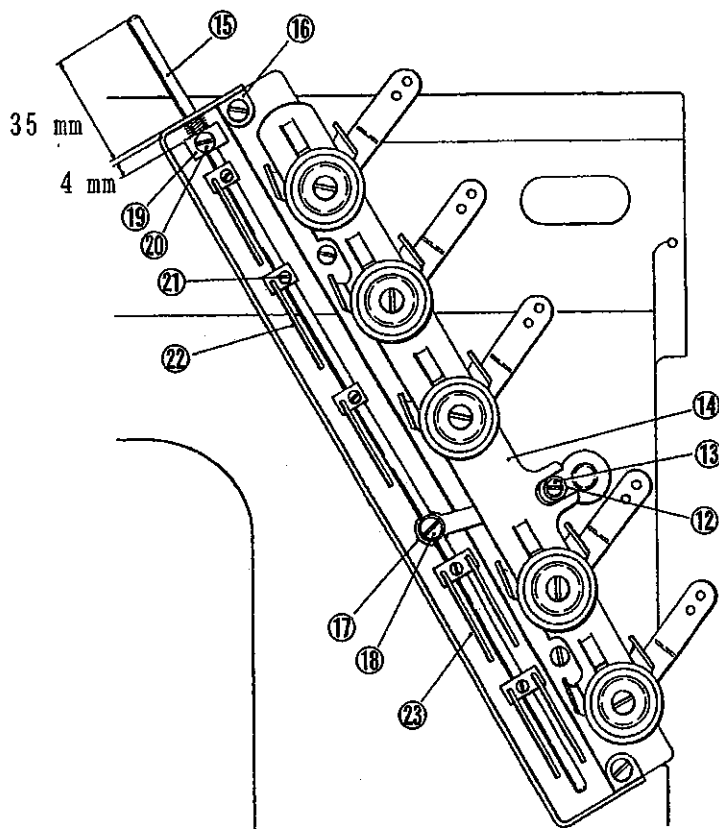

The thread pull-off hook unit²² should be positioned so that needle thread is not remained too much on the top of the fabric at the beginning of sewing.

- (1) Loosen the screw²¹.
- (2) To shorten thread, raise the hook unit²².
To lengthen, lower the hook unit²².

NOTES

- (1) The thread pull-off hook unit²³ should be used only when woolly thread is used for the looper. When the hook unit²³ is not used, raise it to the position where it does not hook thread.
- (2) Take care not to raise the hook unit²² too much. Stitch may not be formed at the beginning of sewing.

Chapter VII . Adjustment of air wiper

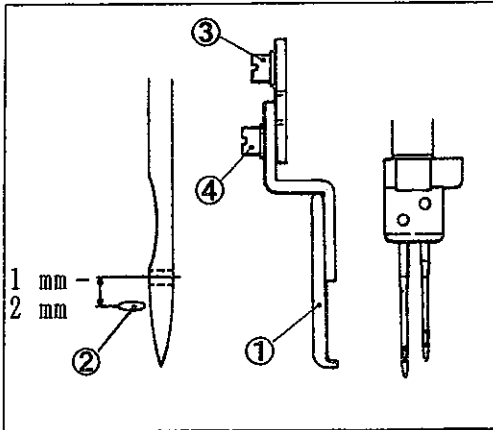

- (1) Loosen the screws③.
- (2) Slide the air wiper① back and forth to position so that the wiper① blows air behind the needle.
- (3) Tighten the screws③.
- (4) Loosen the screws④.
- (5) When the needles are at the top of their travel, position the air wiper① so that the center of the air blowing hole② is 1.0 mm - 2.0 mm below the needle eye of the left needle.
- (6) Tighten the screws④.
- (7) Adjust the air flow with the speed controller⑤.

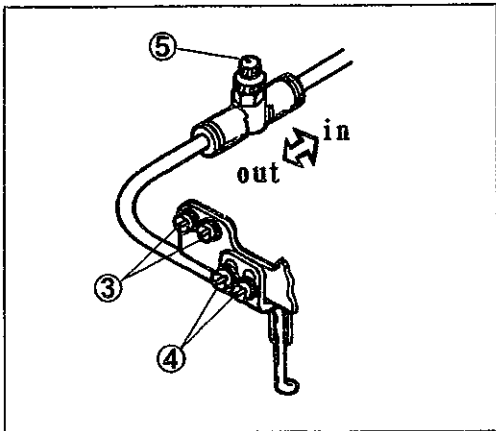

! NOTES

- (1) The air flow should be minimized.
- (2) If air is blown in front of the needles, needle thread may be slipped away from needle eye. Be sure to make it blow behind the needles.

Chapter VIII . Presser foot lifter mechanism



WARNING

ALWAYS turn OFF the motor switch and check that the motor stops before adjustment.

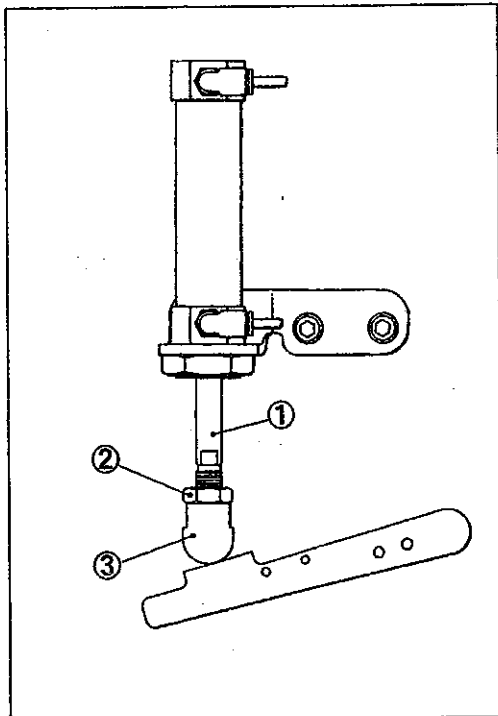

- (1) Loosen the lock nut②.
- (2) Turn the cylinder rod chip③ and adjust so that the presser foot rises by 6 mm (7.5 mm) when the cylinder rod① is at its bottom (when the cylinder operates).
- (3) Tighten the lock nut②.

Chapter IX . ST2-A device

9-1 Position of movable trimming knife

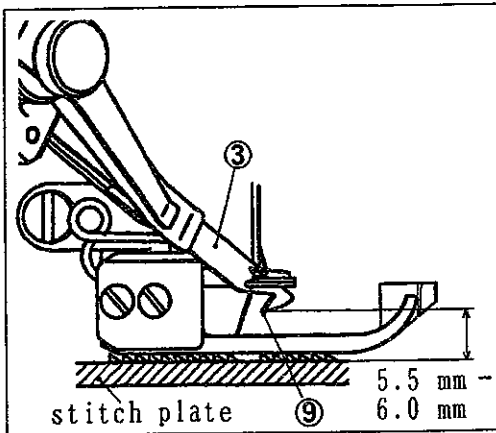
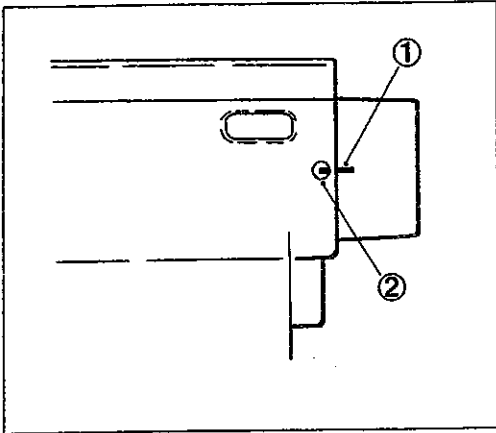

WARNING

ALWAYS turn OFF the motor switch and check that the motor stops before adjustment.

- (1) Align the line ① on the handwheel with the hole ② in the machine arm.
(The needle rises to its top.)
- (2) Insert tweezers or the like into the hole ④ of the movable trimming knife ③ and move the knife ③ to its bottom.

NOTE

Do not touch the knife ③ to the presser foot, the left needle ⑤ and the spreader ⑥. If it touches to them, loosen the screws ⑦ and ⑧ and adjust.

- (3) When the knife ③ is at its bottom, loosen the screw ⑩ and make a distance of 5.5 mm - 6.0 mm from the stitch plate to the point ⑨ of the knife ③.

NOTE

After this adjustment, the knife ③ must cross top cover thread.

- (4) After the above adjustments are finished, tighten the screws ⑦, ⑧, and ⑩.
- (5) Move the knife ③ up and down to check the knife position.

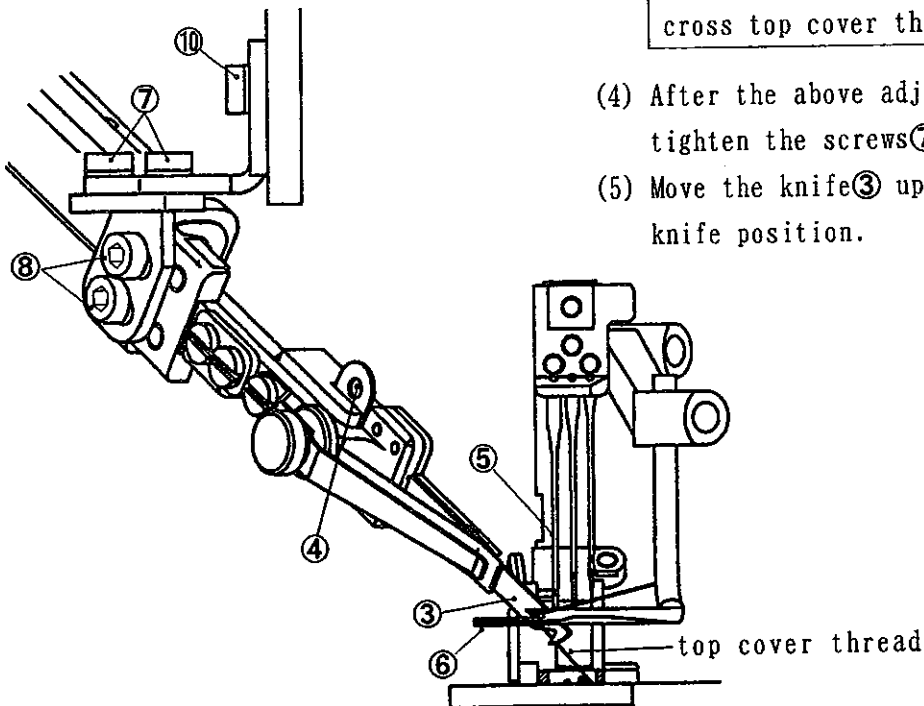

Chapter IX. ST2-A device

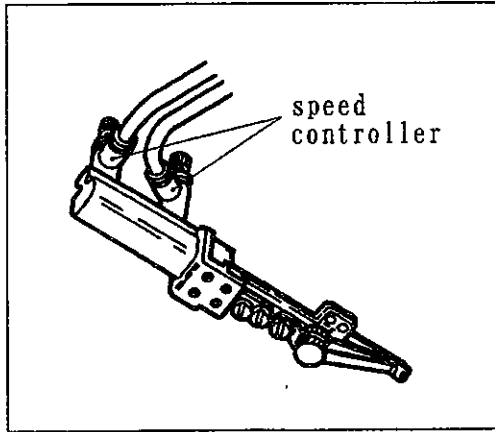

The speed of the movable trimming knife can be adjusted with the speed controller on the air cylinder.

To decrease the speed, loosen the nut on the speed controller and turn the adjusting screw clockwise.

To increase, loosen the nut and turn the screw counterclockwise.

9-2 Engagement between movable trimming knife and fixed trimming knife

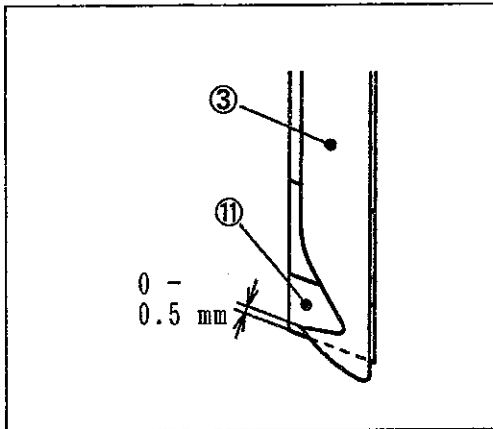

WARNING

ALWAYS turn OFF the motor switch and check that the motor stops before adjustment.

The engagement between the movable trimming knife ③ and the fixed trimming knife ⑪ has been adjusted to 0 - 0.5 mm as shown in the figure. Normally this adjustment is not necessary.

NOTE

The stroke of the movable trimming knife is the same as that of the air cylinder.

Chapter IX . ST2-A device

WARNING

ALWAYS turn OFF the motor switch and check that the motor stops before adjustment.

9-3 Pressure of thread clamp spring

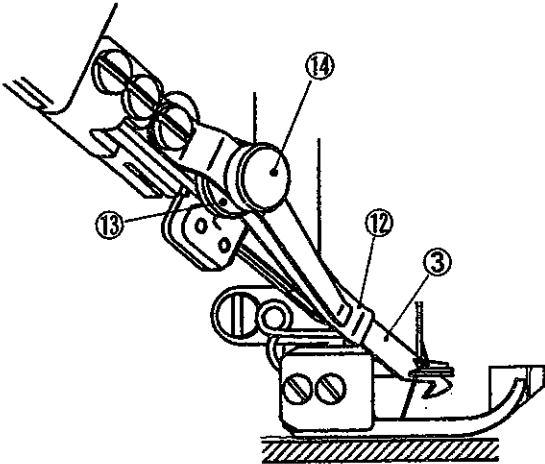

The pressure should be minimized so long as thread can be held.

- (1) Loosen the nut¹³.
- (2) Adjust pressure with the adjusting screw¹⁴ so that the thread clamp¹² and the movable trimming knife³ can hold thread after cut. To increase pressure, tighten the screw¹⁴.

9-4 Adjusting thread pull-off hook unit

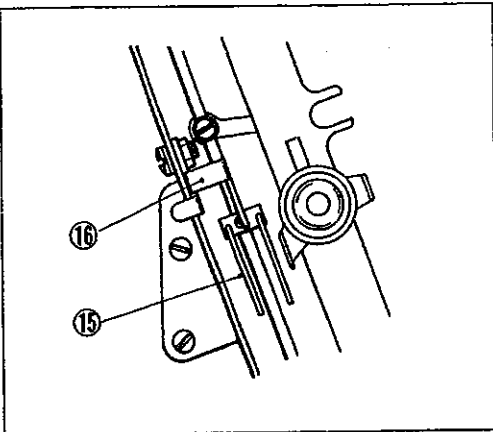

To shorten thread, raise the thread pull-off hook unit¹⁵.

To lengthen, lower the hook unit¹⁵.

NOTES

- (1) The feed of the thread should be as much as possible. If it is not enough, top cover thread can not be held after cut.
- (2) When stretchable thread like woolly thread is used, thread to the top cover thread eyelet¹⁶.

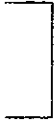
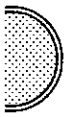

:

'e

UT device

n

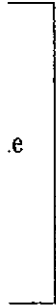

.e

.e



Contents

UT device

Chapter I. Operation	38
1-1 Operating procedure for UT-2 device	38
1-2 Operating procedure for UT-4/ST2 device	39
Chapter II. Wiring	40
2-1 Detector switch	40
2-1-1 Adjusting detector switch	40
2-1-2 Connecting detector switch	40
2-2 Connecting solenoid	41
Chapter III. Installation of synchronizer	42
Chapter IV. Adjustment of thread trimming mechanism	43
4-1 Installing plunger connecting rod	43
4-2 Stroke of solenoid	43
4-3 Adjusting return spring of solenoid	43
4-4 Position of lower knife	44
4-5 Relation between upper knife and lower knife	44
4-6 Position of thread clamp spring and thread clamp spring pressure	45
4-7 Pressure of thread clamp spring	45
4-8 Position of upper knife carrier	46
4-9 Relation between lower knife and needle	47
4-10 Position of lower knife point	48
4-11 Adjusting lower knife carrier guide	49
4-12 Adjusting lower knife carrier guide(upper)	49
4-13 Relation between needle thread, looper thread and lower knife	50

UT device

Chapter V. Adjustment of tension release mechanism	51
5-1 Tension release block	51
5-2 Tension release connecting plate	51
5-3 Thread pull-off lever	51
5-4 Tension disc separator	52
5-5 Thread pull-off hook unit	53
Chapter VI. Adjustment of wiper	54
6-1 Relation between wiper and needle	54
6-2 Movement of wiper	54
6-3 Relation between wiper and thread clamp rubber	54
6-4 Position of solenoid bracket	55
6-5 Position of solenoid lever	55
6-6 Position of wiper	55
Chapter VII. Presser foot lifter mechanism	56
Chapter VIII. ST2 device	57
8-1 Position of movable trimming knife	57
8-2 Engagement between movable trimming knife and fixed trimming knife	58
8-3 Adjusting stroke of movable trimming knife	58
8-4 Pressure of thread clamp spring	59
8-5 Adjusting spring	60
8-6 Adjusting thread pull-off hook unit	61

iew

view

Chapter I . Operation

NOTE

Be sure to place fabric under the presser foot when operating this device.

1-1 Operating procedure for UT-2 device

The needle position during stopping ; 1 position or 2 position can be selected.
Please refer to instruction manuals of motor for the way to switch positions
(1 position \longleftrightarrow 2 position).
The operating procedure for 1 position and 2 position is mentioned below.

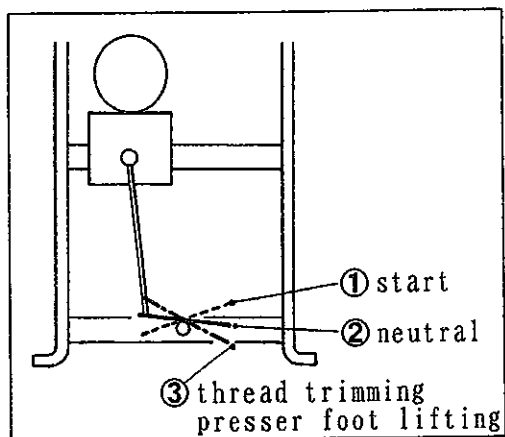

- (1) Load the fabric under the presser foot and press down the pedal to the position①.
➔ The sewing machine starts sewing.
- (2) Release the pedal to the neutral②.
➔ The needle stops at its bottom.
(When 1 position is selected, this item is skipped.)
- (3) Heel back the pedal to the position③.
➔ The needle rises and stops at its top.
The trimming knife mechanism is activated to cut needle thread and looper thread under the stitch plate. The looper thread is held by the thread clamp spring. And then, the wiper mechanism is activated to hold needle thread by the thread clamp rubber. The presser foot rises.
- (4) Release the pedal to the neutral②.
➔ The presser foot lowers.

NOTE

The presser foot can be lifted or lowered by heeling back the pedal to the positions② and ③ until the pedal is pressed down to the position①.

Chapter I . Operation

NOTE

Be sure to place fabric under the presser foot when operating this device.

1-2 Operating procedure for UT-4/ST2 device

The needle position during stopping ; 1 position or 2 position can be selected.
Please refer to instruction manuals of motor for the way to switch positions
(1 position \longleftrightarrow 2 position).

The operating procedure for 1 position and 2 position is mentioned below.

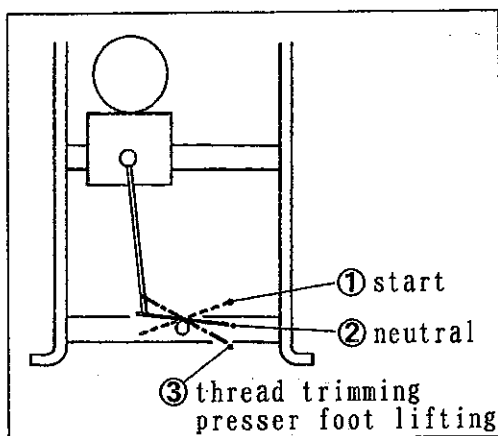

- (1) Load the fabric under the presser foot and press down the pedal to the position①.
➔ The sewing machine starts sewing.
- (2) Release the pedal to the neutral②.
➔ The needle stops at its bottom.
(When 1 position is selected, this item is skipped.)
- (3) Heel back the pedal to the position③.
➔ The needle rises and stops at its top.
The trimming knife mechanism is activated to cut needle thread and looper thread under the stitch plate. The looper thread is held by the thread clamp spring. The ST2 device cuts and holds top cover thread.
- (4) Release the pedal to the neutral②.
➔ The presser foot lowers.

NOTE

The presser foot can be lifted or lowered by heeling back the pedal to the positions② and ③ until the pedal is pressed down to the position①.

Chapter II . Wiring

2-1 Detector switch

2-1-1 Adjusting detector switch

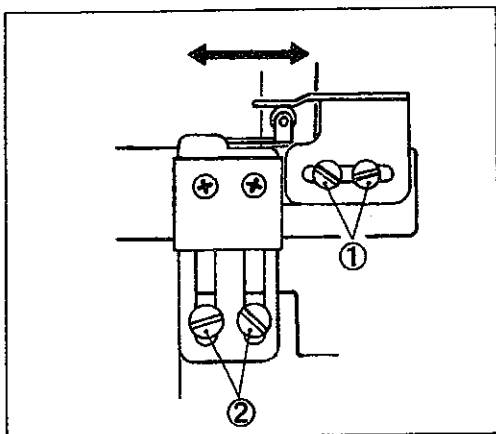

The detector switch is equipped not to run the machine until the trimming knife returns.

For adjustment:

- (1) Loosen the screws① and ②.
- (2) Adjust so that the switch is turned ON when the trimming knife returns to the original position.
- (3) Tighten the screws① and ②.

2-1-2 Connecting detector switch

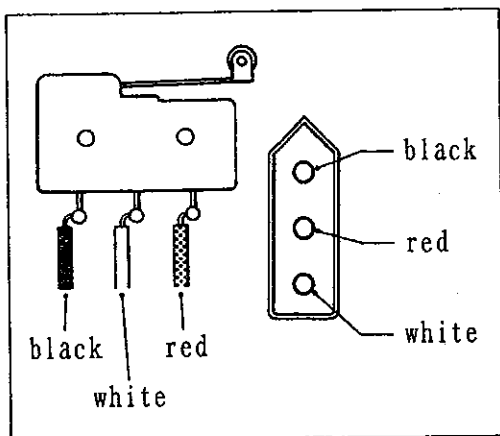

Connect the cords from the detector switch to the 3P-connector as shown in the figure.

Chapter II . Wiring

2-2 Connecting solenoid

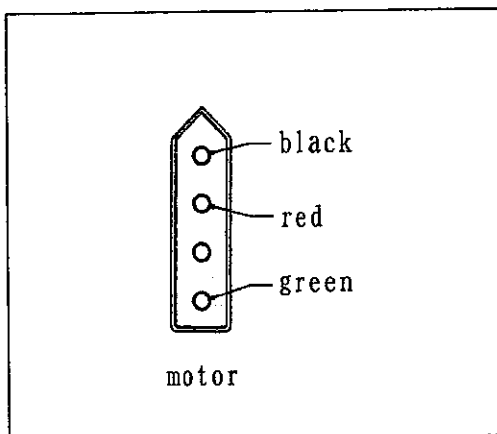
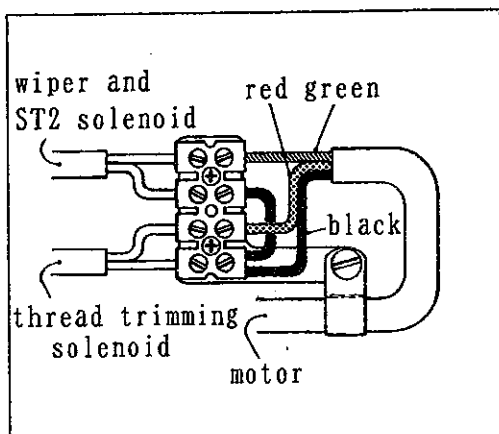

⚠ CAUTION

NEVER short-circuit black and red or black and green.

Inside circuit may be damaged.

Chapter III . Installation of synchronizer

⚠ CAUTION

Remove the plug for the trimming solenoid from the control box for the motor.
The parts may be contacted and broken.

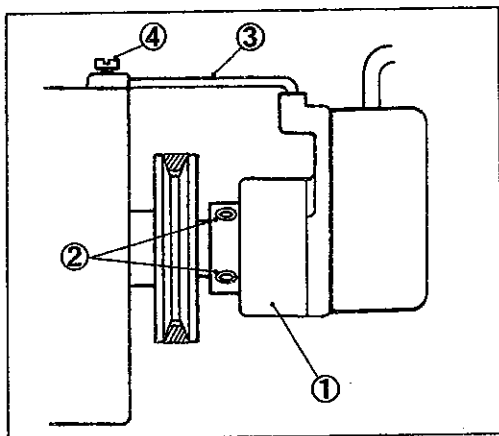

- (1) Install the synchronizer① on the machine pulley and tighten the screws② lightly.
- (2) Insert the positioning pin③ in the groove of the synchronizer① and tighten the screw④.
- (3) Turn ON the motor switch.
- (4) Press down the pedal to sew two or three stitches.

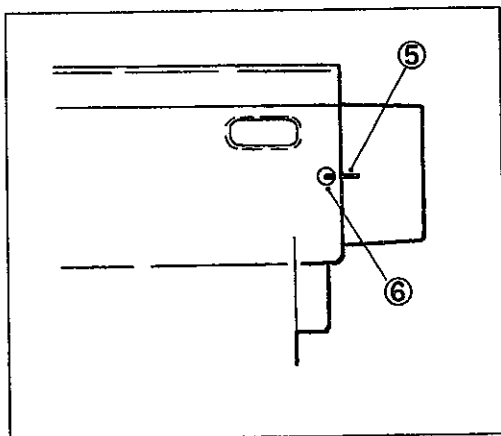

- (5) Heel back the pedal and the needle stops at a certain position.
- (6) Loosen the screws② and turn the pulley clockwise to align the line⑤ on the handwheel with the hole⑥ in the machine arm, taking care not to shift the position of the screws②.

NOTES

- (1) The needle bar is at the top of its travel.
- (2) This device is in good condition when the needle bar is at the position from the top to 0.5 mm below by further turning the pulley.

- (7) Press down the pedal to run the machine for a few stitches to check that the needle bar stops at the position from the top to 0.5 mm below.

WARNING

ALWAYS turn OFF the motor switch and check that the motor stops before adjustment.

4-1 Installing plunger connecting rod

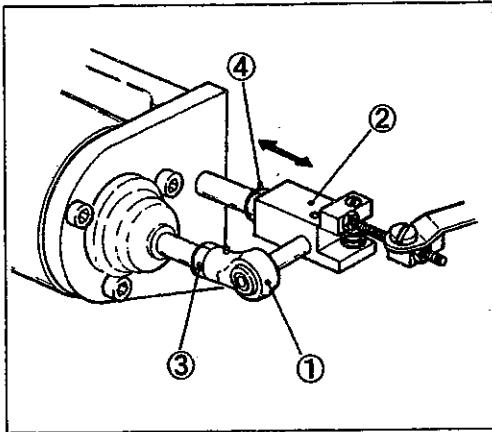

- (1) Install the plunger connecting rod① to the shaft of the trimming solenoid with the nut③.
- (2) Insert the pin of the plunger② to the rod①.
- (3) Install the plunger② to the solenoid return shaft with the nut④.
- (4) Check that the shaft of the solenoid can slide smoothly by moving the shaft right or left.

4-2 Stroke of solenoid

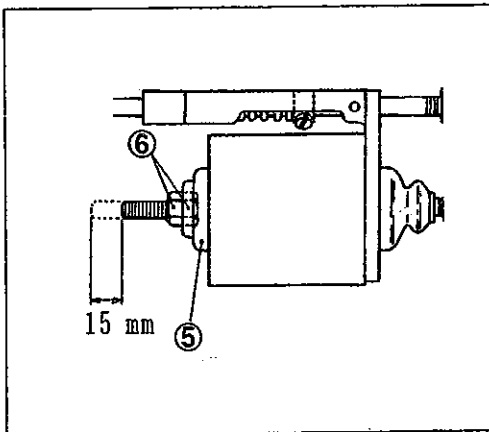

The proper stroke is 15 mm.

For adjustment, remove the dust-proof cover⑤ to loosen the nuts⑥.

NOTE

When the stroke of the solenoid is changed, readjust the action of the thread trimming mechanism. Check the condition of the detector switch. (See the section '2-1-1 Adjusting detector switch' on page 33.)

4-3 Adjusting return spring of solenoid

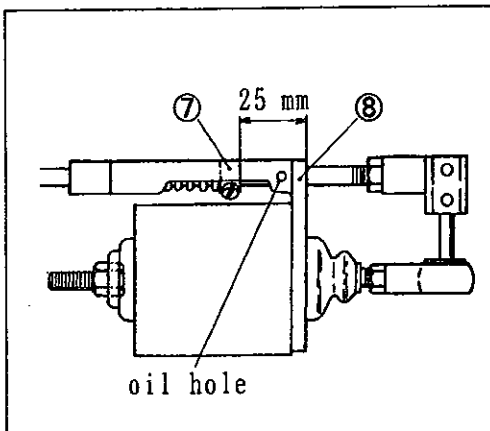

The standard position of the collar⑦ is 25 mm from the end of trimming solenoid support⑧ when the plunger is at its extreme left. (The solenoid is not in the operating condition.)

NOTE

Supply oil to the oil hole (red marked) on the support⑧ once a week.

Chapter IV . Adjustment of thread trimming mechanism

WARNING

ALWAYS turn OFF the motor switch and check that the motor stops before adjustment.

4-4 Position of lower knife

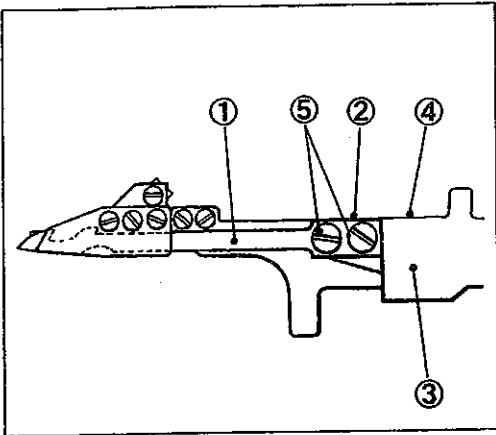

CAUTION

The trimming knife mechanism can be operated manually only when the needle is at its top. If the needles are not at the top, the parts may be contacted and broken.

- (1) Make the side ② of the lower knife ① parallel with the side ④ of the lower knife carrier ③.
- (2) Fix with the screws ⑤.

4-5 Relation between upper knife and lower knife

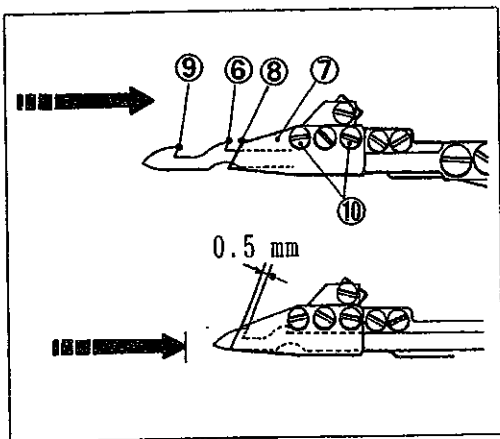

- (1) Loosen the screws ⑩.
- (2) Align the hook ⑥ for needle thread of the lower knife with the corner ⑧ of the upper knife ⑦.
- (3) When the lower knife is at the extreme right, move the upper knife ⑦ right and left to make an engagement of 0.5 mm between the hook ⑨ for looper thread and the upper knife ⑦.
- (4) Tighten the screws ⑩.

Chapter IV . Adjustment of thread trimming mechanism



WARNING

ALWAYS turn OFF the motor switch and check that the motor stops before adjustment.

4-6 Position of thread clamp spring and thread clamp spring pressure

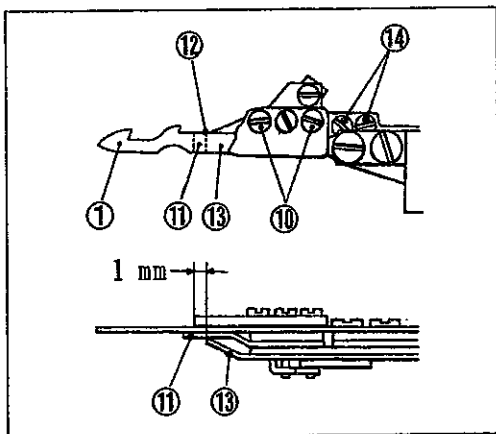

- (1) Loosen the screws⑩.
- (2) Make the side of the thread clamp spring⑪ even with the side⑫ of the lower knife①.
- (3) Tighten the screws⑩.
- (4) Loosen the screws⑭.
- (5) Make the side of the thread clamp spring pressure⑬ even with the sides of the lower knife① and the spring⑪.
- (6) Make a distance of 1.0 mm from the tip of the pressure⑬ to that of the upper knife.
- (7) Tighten the screws⑭.

4-7 Pressure of thread clamp spring

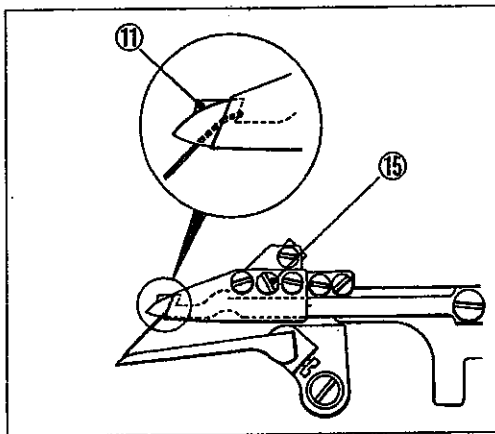

Looper thread is held by the thread clamp spring⑪ after cut.

To increase the pressure, turn the adjusting screw⑮ clockwise.

To decrease, turn the screw⑮ counterclockwise.

NOTE

The pressure should be minimized so long as looper thread can be held.

Chapter IV . Adjustment of thread trimming mechanism

WARNING

ALWAYS turn OFF the motor switch and check that the motor stops before adjustment.

4-8 Position of upper knife carrier

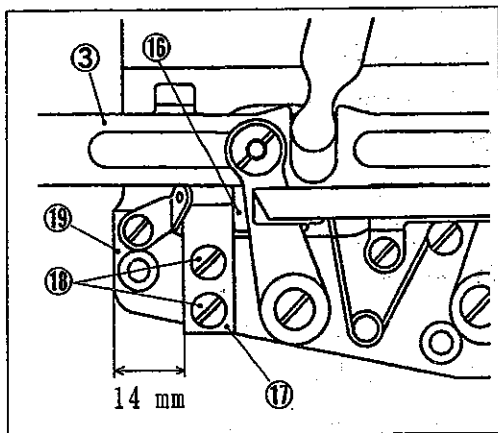

The upper knife carrier¹⁶ slides to the left simultaneously with the lower knife carrier³ and stops by touching the upper knife carrier stopper¹⁷. The upper knife slides under the stitch plate.

CAUTION

NEVER slide the carrier¹⁶ to the left too much, because the thread clamp spring pressure touches the looper.

For adjustment:

- (1) Loosen the screws¹⁸.
- (2) Make a distance of 14 mm between the left end of the crank chamber cover¹⁹ and that of the stopper¹⁷.
- (3) Tighten the screws¹⁸.

WARNING

ALWAYS turn OFF the motor switch and check that the motor stops before adjustment.

4-9 Relation between lower knife and needle

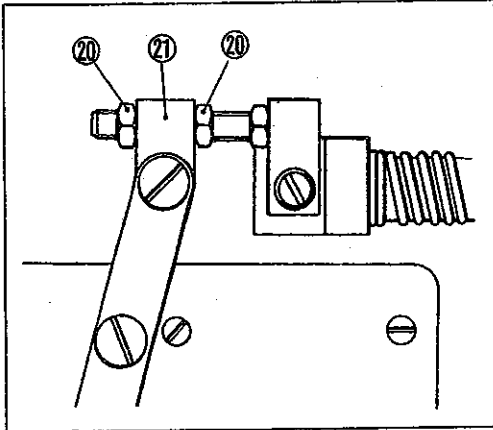

- (1) Loosen the nuts②0.
- (2) Move the lower knife① to the extreme left.
- (3) Adjust the connecting block② to the right and left to make a distance of 3.5 mm - 4.5 mm from the hook⑥ for needle thread to the left needle.
- (4) Tighten the nuts②0.

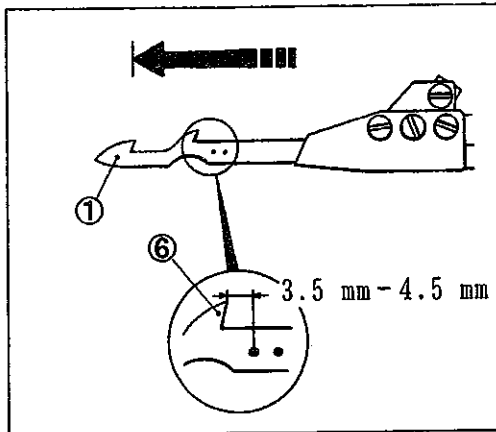

Chapter IV . Adjustment of thread trimming mechanism

WARNING

ALWAYS turn OFF the motor switch and check that the motor stops before adjustment.

4-10 Position of lower knife point

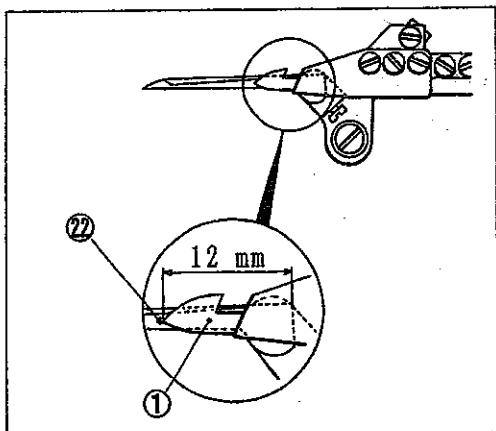

- (1) Slide the lower knife① to the left.
- (2) When the distance between the point② of the knife① and the right end of the looper is 12 mm, center the point② on the top of the looper.
- (3) To slide the point② rearward, loosen the screw③ to turn the knife guide lever ring (right)④ clockwise.
To slide forward, turn the ring(right)④ counterclockwise.
- (4) Tighten the screw③.

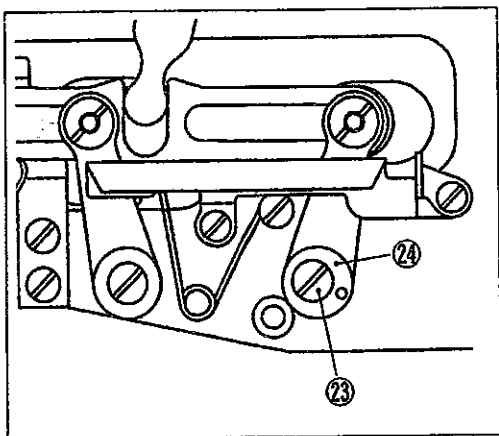

WARNING

ALWAYS turn OFF the motor switch and check that the motor stops before adjustment.

4-11 Adjusting lower knife carrier guide

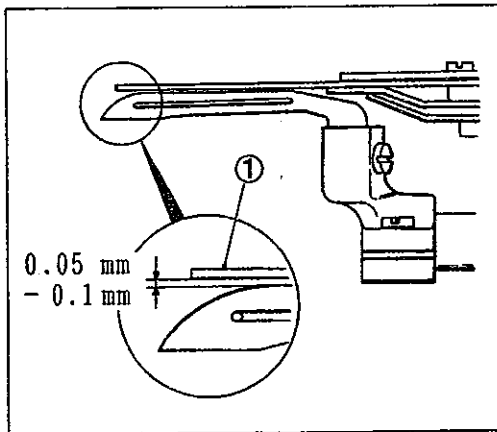

The proper distance is 0.05 mm - 0.1 mm between the lower knife ① and the top of the looper.

- (1) Loosen the screw ②⑤ and move the lower knife carrier guide ②⑥ up and down.
- (2) Tighten the screw ②⑤.
- (3) Check that the upper knife carrier and the lower knife carrier can move smoothly.

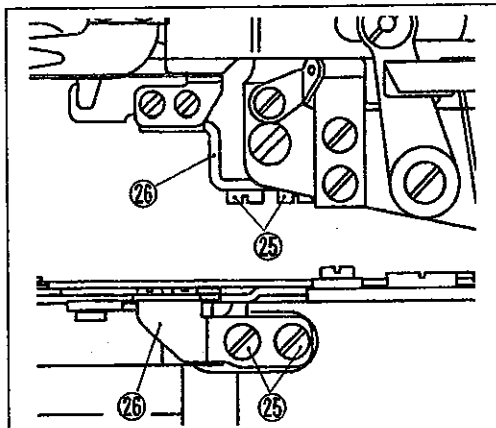

4-12 Adjusting lower knife carrier guide(upper)

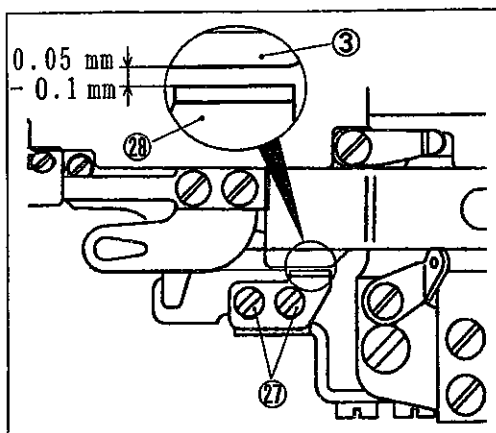

The upper knife carrier slides to the left simultaneously with the lower knife carrier and stops by touching the upper knife carrier stopper.

- (1) Loosen the screws ②⑦.
- (2) When the upper knife carrier is stopped as mentioned above, make a distance of 0.05 mm - 0.1 mm between the lower knife carrier ③ and the lower knife carrier guide(upper) ②⑧.
- (3) Tighten the screws ②⑦.

Chapter IV . Adjustment of thread trimming mechanism

WARNING

ALWAYS turn OFF the motor switch and check that the motor stops before adjustment.

4-13 Relation between needle thread, looper thread and lower knife

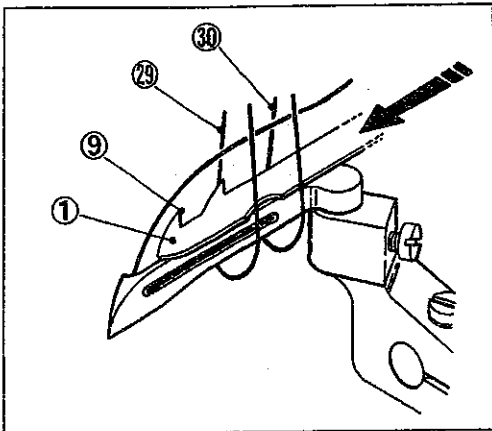

Before sewing performance, be sure to check as follows:

- The lower knife① passes through the loops②⑨ and ⑩ of needle thread.

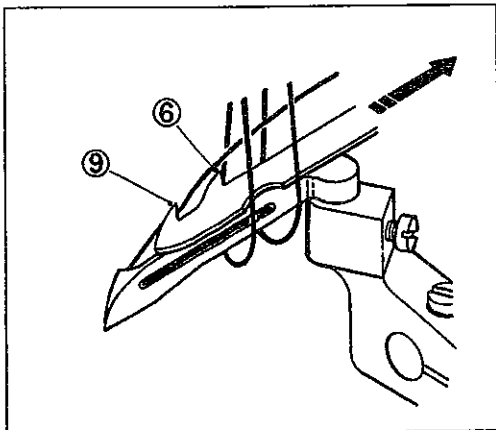

- The hook⑨ for looper thread moves in front of looper thread.
- The needle thread is pulled to the right by the hook⑥ to be cut by the upper knife.
- The looper thread is pulled to the right by the hook⑨ to be cut by the upper knife.

WARNING

ALWAYS turn OFF the motor switch and check that the motor stops before adjustment.

5-1 Tension release block

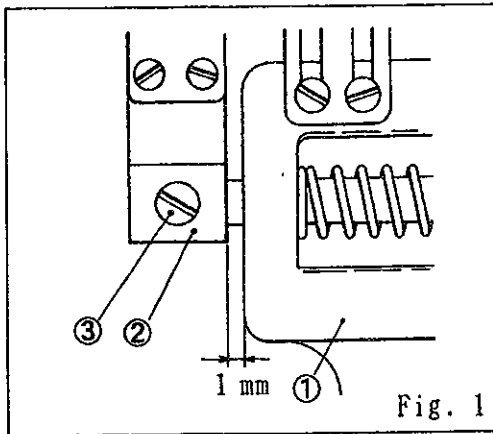

Fig. 1

- (1) Loosen the screw③.
- (2) When the rod of the trimming solenoid is at its extreme left, (The trimming knife does not operate.) make a space of 1.0 mm between the trimming solenoid support① and the tension release block②.
- (3) Tighten the screw③.

5-2 Tension release connecting plate

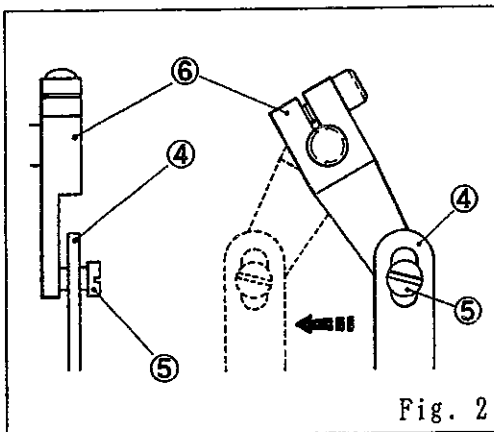

Fig. 2

See the figures 1 and 2.

- (1) Loosen the screw③.
- (2) Adjust the position of the tension release block② so that the tension release connecting plate④ is in the middle of the screw head⑤ and the tension release lever⑥.
- (3) Tighten the screw③.

5-3 Thread pull-off lever

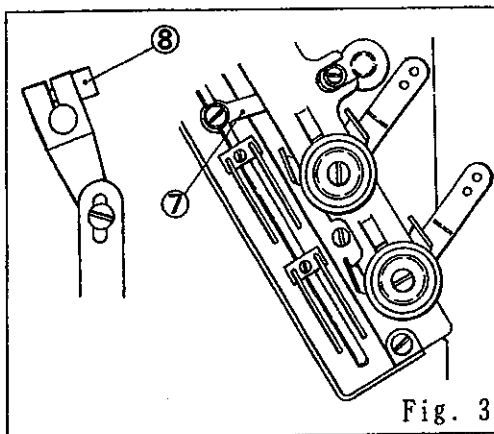

Fig. 3

- (1) Loosen the screw⑧ of the tension release lever on the back of the machine frame unit.
- (2) Raise the thread pull-off lever⑦ to its top.
- (3) Tighten the screw⑧.

Chapter V . Adjustment of tension release mechanism

5-4 Tension disc separator



WARNING

ALWAYS turn OFF the motor switch and check that the motor stops before adjustment.

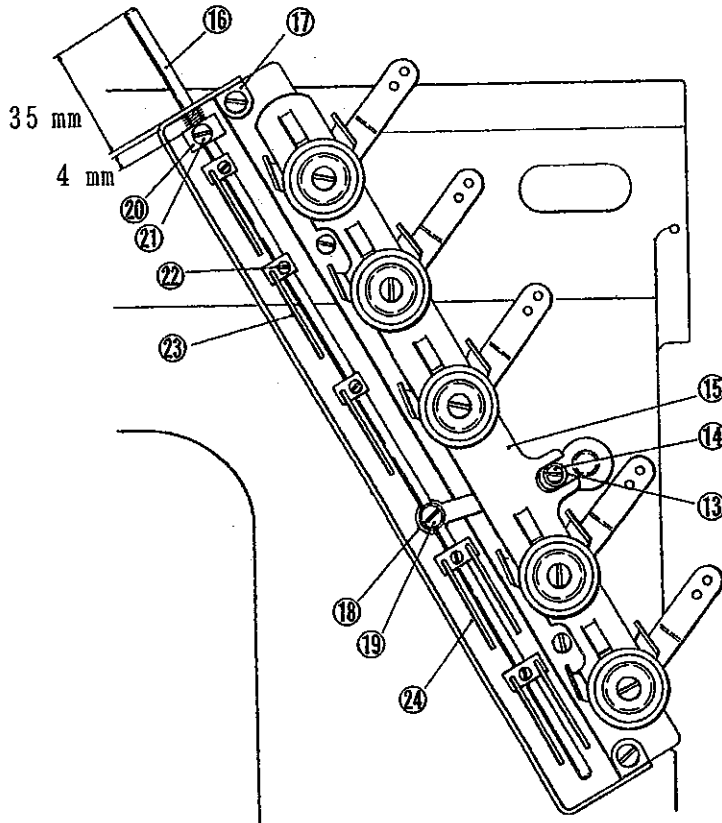

- (1) Loosen the screw¹⁴ of the tension release adjusting eccentric¹³.
- (2) Position the tension disc separator¹⁵ by turning the eccentric¹³ so that the thread tension discs can open as soon as possible. To open as soon as possible, lower the separator¹⁵.
- (3) Loosen the screw¹⁹ to make a distance of 35 mm from the top of the tension pull-off bar¹⁶ to that of the thread pull-off eyelet¹⁷.
- (4) Fix the bar¹⁶ to the thread pull-off bar holder¹⁸ with the screw¹⁹.
- (5) Loosen the screw²¹.
- (6) Make a distance of 4.0 mm between the collar²⁰ and the eyelet¹⁷.
- (7) Tighten the screw²¹.

5-5 Thread pull-off hook unit



WARNING

ALWAYS turn OFF the motor switch and check that the motor stops before adjustment.

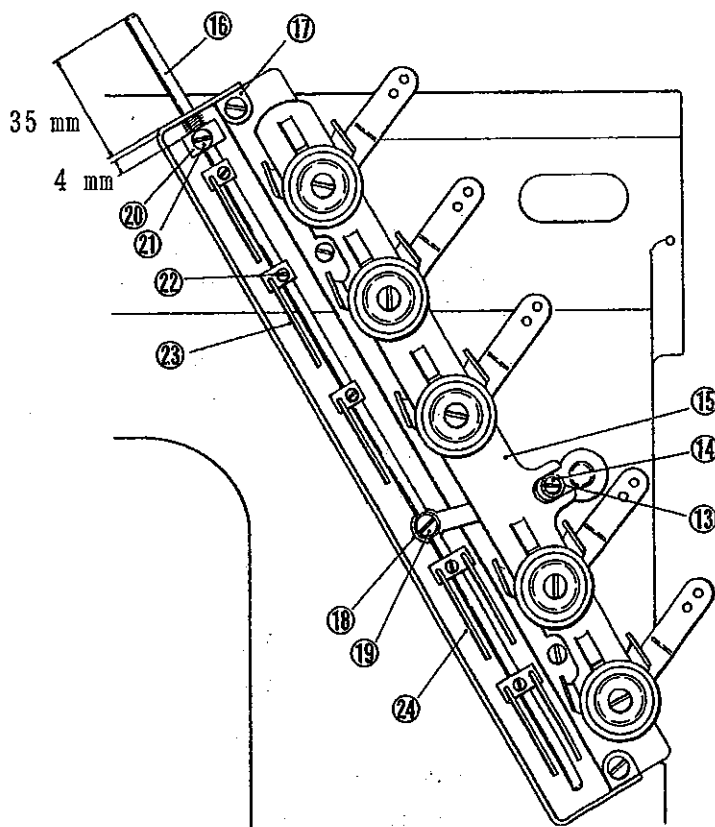

The thread pull-off hook unit²³ should be positioned so that needle thread is not remained too much on the top of the fabric at the beginning of sewing.

- (1) Loosen the screw²².
- (2) To shorten thread, raise the hook unit²³.
To lengthen, lower the hook unit²³.



NOTES

- (1) The thread pull-off hook unit²⁴ should be used only when woolly thread is used for the looper. When the hook unit²⁴ is not used, raise it to the position where it does not hook thread.
- (2) Take care not to raise the hook unit²³ too much. Stitch may not be formed at the beginning of sewing.

Chapter VI . Adjustment of wiper

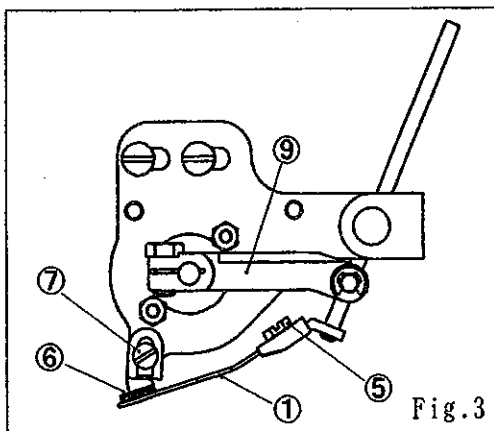
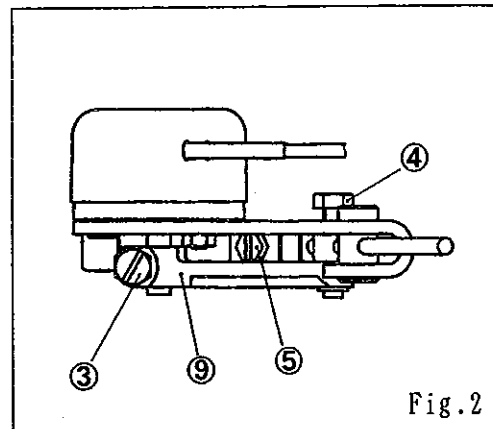
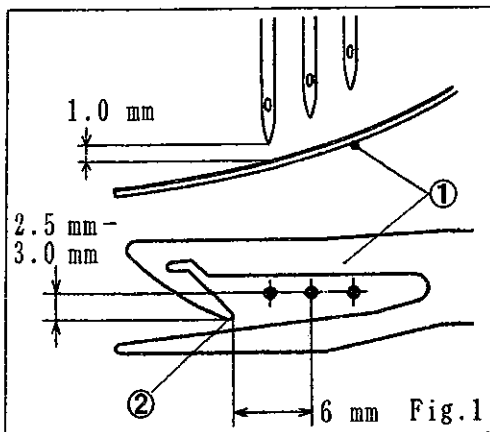

6-1 Relation between wiper and needle

When the solenoid operates, the shaft of the solenoid moves toward operator by 0.9 mm while it rotates. When the following adjustment is carried out, move down the solenoid lever^⑨ with it pulled toward operator.

- (1) Move the needles to their top.
- (2) Loosen the screw^③ and adjust so that the hook^② of the wiper^① passes in front of the needles 2.5 mm - 3.0 mm away from the center of the needles. (Fig. 1, Fig. 2)
- (3) Loosen the screw^④ and adjust so that the wiper^① passes 1.0 mm below the left needle. (Fig. 1, Fig. 2)

6-2 Movement of wiper

When the wiper^① is at the extreme left, loosen the screw^⑤ of the wiper holder and adjust so that a distance from the center of the needle bar to the hook^② is 6.0 mm. (Fig. 1, Fig. 2)

6-3 Relation between wiper and thread clamp rubber

Loosen the screw^⑦ and adjust so that the thread clamp rubber^⑥ and the wiper^① can hold needle thread lightly when the wiper^① returns to its extreme right. (Fig. 3)

Chapter VI. Adjustment of wiper

6-4 Position of solenoid bracket

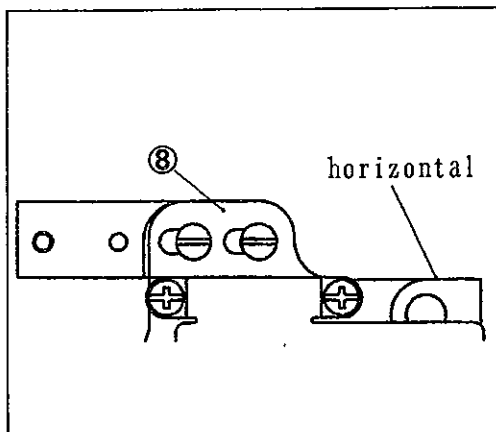

Move the solenoid bracket⑧ to the extreme left.

6-5 Position of solenoid lever

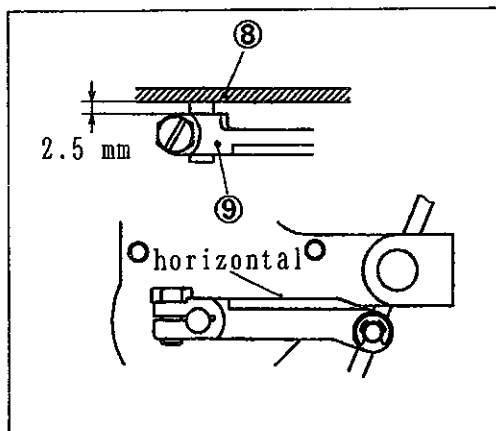

Make a distance of 2.5 mm between the solenoid bracket⑧ and the solenoid lever⑨.

When the lever⑨ is returned, the lever⑨ must be horizontal.

6-6 Position of wiper

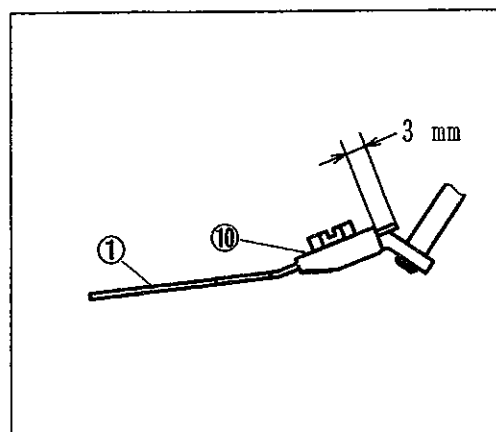

Adjust the wiper① to make a distance of 3 mm from the end of the wiper① to the wiper holder⑩.

Chapter VII. Presser foot lifter mechanism

WARNING

ALWAYS turn OFF the motor switch and check that the motor stops before adjustment.

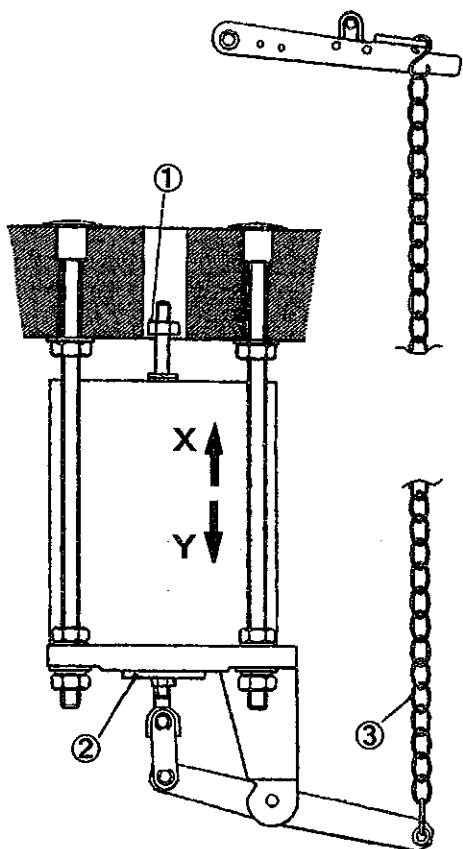

- (1) Fix the nut① to the plunger②.
- (2) Adjust with chain③ so that the presser foot can rise by 6 mm (with no spreader: 7.5 mm) when the plunger② is moved toward (X). (The solenoid operates.)
- (3) Adjust with chain③ so that the chain③ has a slight sag when the plunger② is moved toward (Y).

Chapter VIII . ST2 device

8-1 Position of movable trimming knife

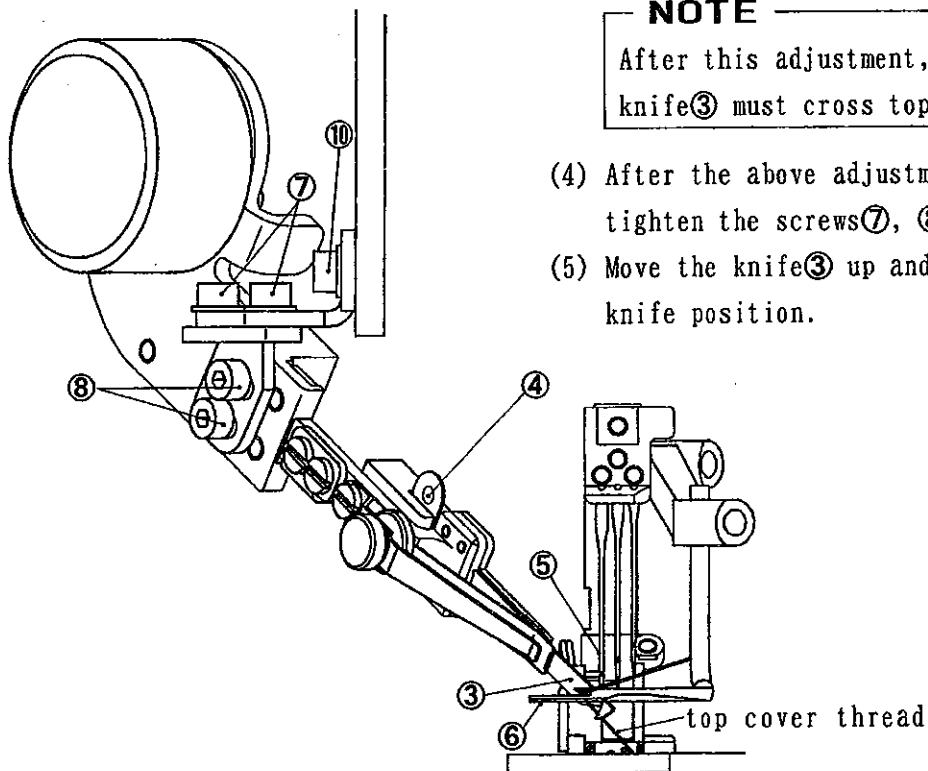
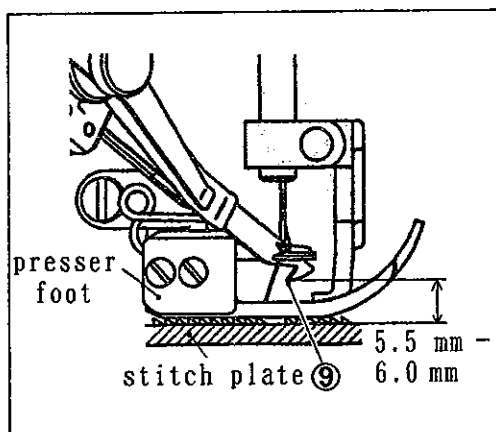
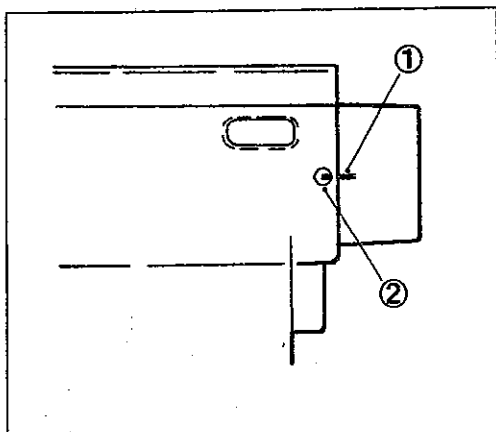

WARNING

ALWAYS turn OFF the motor switch and check that the motor stops before adjustment.

- (1) Align the line ① on the handwheel with the hole ② in the machine arm.
(The needle rises to its top.)
- (2) Insert tweezers or the like into the hole ④ of the movable trimming knife ③ and move the knife ③ to its bottom.

NOTE

Do not touch the knife ③ to the presser foot, the left needle ⑤ and the spreader ⑥. If it touches to them, loosen the screws ⑦ and ⑧ and adjust.

- (3) When the knife ③ is at its bottom, loosen the screw ⑧ and make a distance of 5.5 mm - 6.0 mm from the stitch plate to the point ⑨ of the knife ③.

NOTE

After this adjustment, the point ⑨ of the knife ③ must cross top cover thread.

- (4) After the above adjustments are finished, tighten the screws ⑦, ⑧, and ⑩.
- (5) Move the knife ③ up and down to check the knife position.

Chapter VIII . ST2 device

WARNING

ALWAYS turn OFF the motor switch and check that the motor stops before adjustment.

8-2 Engagement between movable trimming knife and fixed trimming knife

The engagement between the movable trimming knife③ and the fixed trimming knife⑪ has been adjusted to 0 - 0.5 mm when delivered. When the knife③ is retreated fully, loosen the screw⑬ of the solenoid lever⑫ and adjust so that the engagement between the movable knife③ and the fixed knife⑪ is 0 - 0.5 mm.

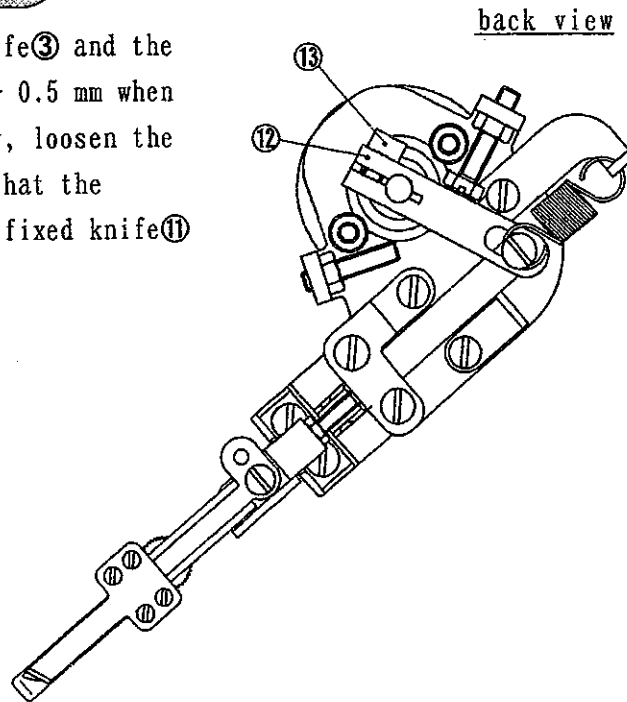
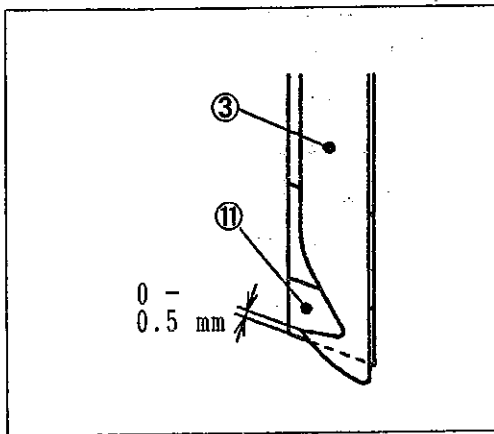

back view

8-3 Adjusting stroke of movable trimming knife

The distance has been set to 19.5 mm from the point⑨ of the movable trimming knife③ to the fixed trimming knife⑪ when delivered.

- (1) Loosen the nut⑮.
- (2) When the movable trimming knife③ is advanced fully and the distance is 19.5 mm from the knife⑪, touch the end of the adjusting screw⑭ to the solenoid lever⑫.
- (3) Tighten the nut⑮

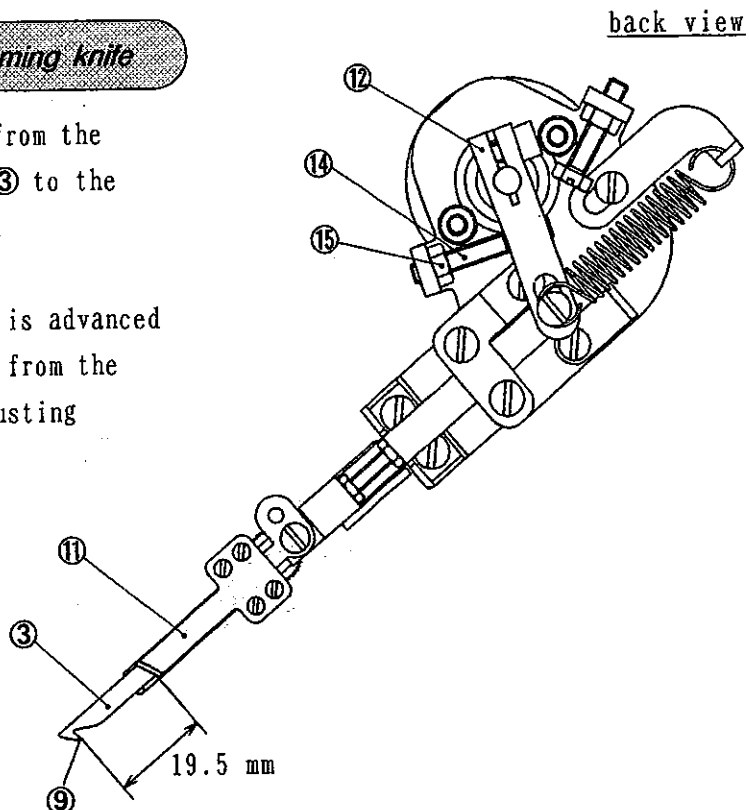

back view

Chapter VIII . ST2 device



WARNING

ALWAYS turn OFF the motor switch and check that the motor stops before adjustment.

8-4 Pressure of thread clamp spring

The pressure should be minimized so long as thread can be held.

- (1) Loosen the nut⑯.
- (2) Adjust the pressure with the adjusting screw⑱ so that the thread clamp⑰ and the movable trimming knife③ can hold thread after cut.
To increase the pressure, turn the screw⑱ clockwise.
- (3) Tighten the nut⑯.

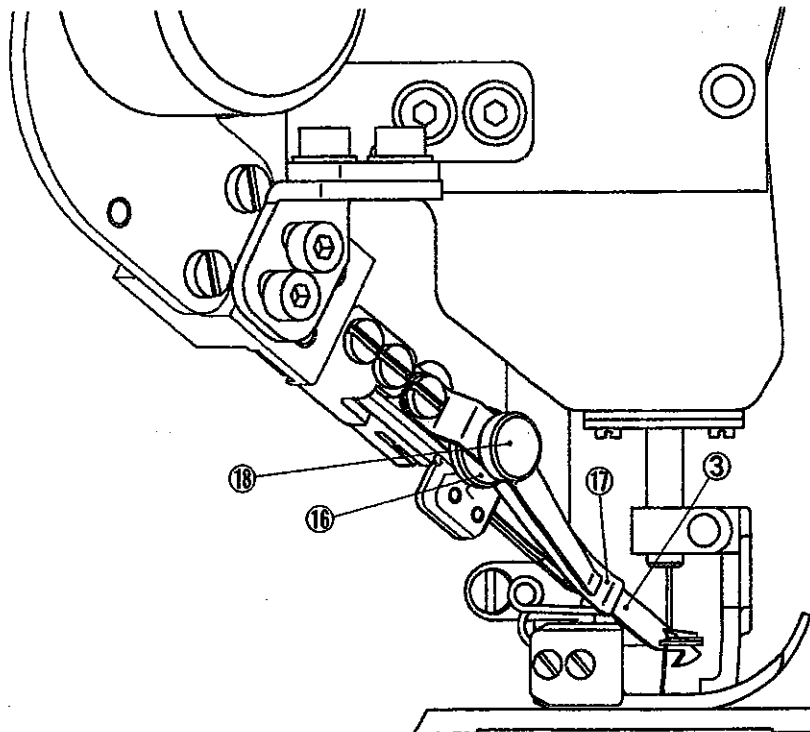

Chapter VIII . ST2 device



WARNING

ALWAYS turn OFF the motor switch and check that the motor stops before adjustment.

8-5 Adjusting spring

back view

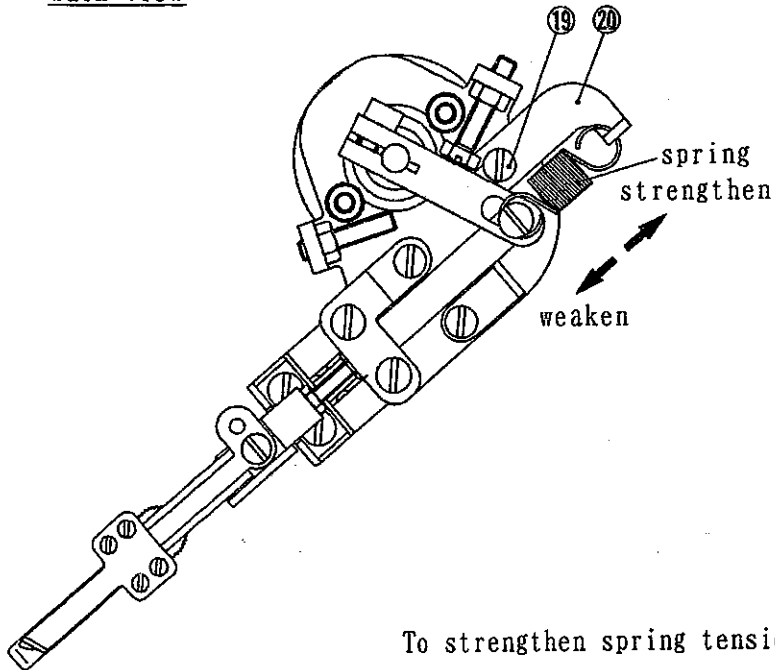

To strengthen spring tension when the movable trimming knife③ is returned, loosen the screw⑱ and move the spring hanger⑳ upward.

To weaken, move the hanger⑳ downward.

NOTE

The spring tension should be minimized so long as the movable trimming knife③ can return.

Chapter VIII . ST2 device



WARNING

ALWAYS turn OFF the motor switch and check that the motor stops before adjustment.

8-6 Adjusting thread pull-off hook unit

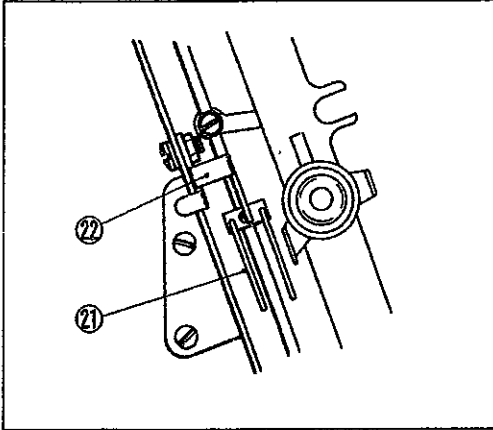

To shorten thread, raise the thread pull-off hook unit②.

To lengthen, lower the hook unit①.

NOTES

- (1) The feed of the thread should be as much as possible. If it is not enough, top cover thread can not be held after cut.
- (2) When stretchable thread like woolly thread is used, thread to the top cover thread eyelet②.

Yamato

ヤマトマシン製造株式会社

YAMATO SEWING MACHINE MFG. CO., LTD.

4-4-12, NISHITENMA, KITA-KU, OSAKA, JAPAN
TEL: 81-6-6364-1321 FAX: 81-6-6364-1307

〒530-0047 大阪市北区西天満4丁目4番12号
TEL (06)6364-1321(代)
FAX (06)6365-5176