

***Yamato***<sup>®</sup>

INSTRUCTIONS  
FOR  
CLASS VE2700

HIGH SPEED EXTRA SMALL CYLINDER BED  
CHAINSTITCH MACHINE



# CONTENTS

	Page
1. Specifications . . . . .	1
2. Installation . . . . .	2
2-1 Notice for carrying . . . . .	2
2-2 Installing Belt Cover . . . . .	2
2-3 Installing Eye Guard and Finger Guard . . . . .	2
2-4 Cutting diagram . . . . .	3
2-5 Table top installation . . . . .	6
2-6 Semi-submerged installation . . . . .	6
3. Sewing Speed and Rotating Direction of Pulley . . . . .	6
4. Motor and Belt . . . . .	6
5. Lubrication . . . . .	7
5-1 Supplying oil . . . . .	7
5-2 Replacing oil . . . . .	7
5-3 Checking and replacing Oil Filter . . . . .	7
5-4 Cleaning Sewing Machine . . . . .	8
6. Proper Operation . . . . .	8
6-1 Needle system and installing . . . . .	8
6-2 Threading . . . . .	9
6-3 Thread tension . . . . .	10
6-4 Presser Foot pressure . . . . .	10
6-5 Right-left position of Presser Foot . . . . .	10
6-6 Adjustment for lowering and raising the front of Presser Foot . . . . .	10
6-7 Adjusting stitch length . . . . .	11
6-8 Adjusting differential feed ratio . . . . .	11
6-9 SP Device (for needle thread oiling) . . . . .	11
7. Adjustment of Sewing Machine . . . . .	12
7-1 Needle thread tension . . . . .	12
7-2 Top cover thread tension . . . . .	13
7-3 Looper thread tension . . . . .	13
7-4 Position of Looper Thread Take-up . . . . .	13
7-5 Removing Presser Foot and Presser Foot lift . . . . .	14
7-6 Relation between Needle and Stitch Plate . . . . .	14
7-7 Angle and height of Looper . . . . .	14
7-8 Distance between Needle and Looper . . . . .	15
7-9 Using Timing Gauge . . . . .	15
7-10 Height of Needle Bar . . . . .	15
7-11 Longitudinal position of Needle and Looper . . . . .	16
7-12 Needle and Needle Guard(Rear) . . . . .	16
7-13 Needle and Needle Guard(Front) . . . . .	17
7-14 Height of Feed Dog . . . . .	17
7-15 Needle and Spreader . . . . .	18
8. Adjustment of Puller Mechanism(VE2740PR) . . . . .	19
8-1 Position of Upper Feed Roller . . . . .	19
8-2 Pressure of Upper Feed Roller . . . . .	19
8-3 Adjustment of feed amount of Puller . . . . .	20
8-4 Adjustment of lifting amount of Upper Feed Roller . . . . .	20

## 1. Specifications

Model	VE2700 Class
Description	High Speed Extra Small Cylinder Bed 3-Needle Chainstitch Machine
Dimensions	445(L) × 270(W) × 405(H) mm
Circumference of Cylinder Bed	180 mm
Weight	39 kg
Stitch Type	ISO 406, 407, 602, 605
Application	Covering seam and hemming bottom on knitted fabric
Sewing Speed	max. 4500 s.p.m.
Stitch Length	1.4 - 4.2 mm, number of stitch: 6 - 18 stitch/inch 7 - 21 stitch/30 mm
Needle System	UY×128GAS (UY128GAS) #65 - #90
Needle Distance	3 needles: 4.8, 5.6, 6.4 mm
Needle Stroke	33 mm
Presser Foot Lift	max. 7.0 mm (With Spreader: 5.0 mm)
Feed Regulation	by Control Lever or Adjusting Knob
Differential Ratio	max. normal differential ratio: 1:1.4 max. reverse differential ratio: 1:0.8
Differential Feed Regulation	by Control Lever ("Banana" type, adjustable with screwdriver)
Lubrication	Automatic lubrication by Oil Pump (combined use with splashing lubrication)
Lubrication Oil	YAMATO SF OIL No. 28
Capacity of Oil Reservoir	1000 cc
Installation	Table top installation or semi-submerged type

## 2. Installation

### 2-1 Notice for carrying

When carrying, **ALWAYS** hold Machine Arm and Handwheel as shown in the right figure. **NEVER** hold cylinder, because it may be broken.

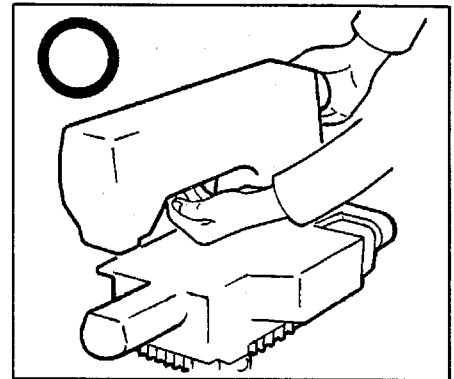
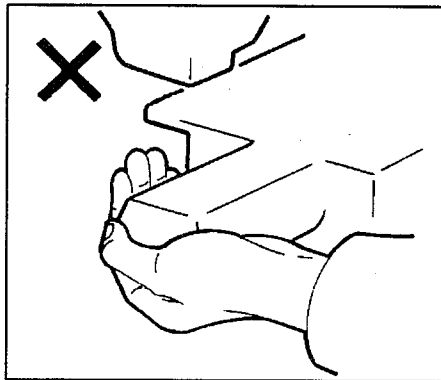

### 2-2 Installing Belt Cover

For safety, be sure to install Belt Cover①.  
If not, your hair, fingers, or others may be wound.

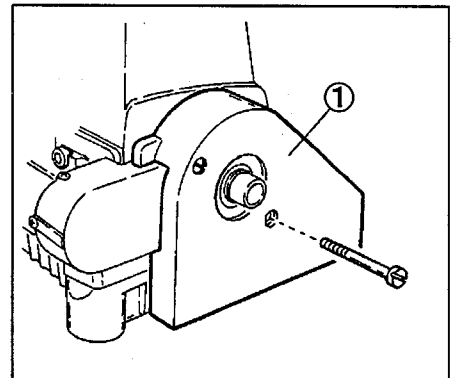

### 2-3 Installing Eye Guard and Finger Guard

For safety, be sure to install Eye Guard② and  
Finger Guard③ at their own positions.

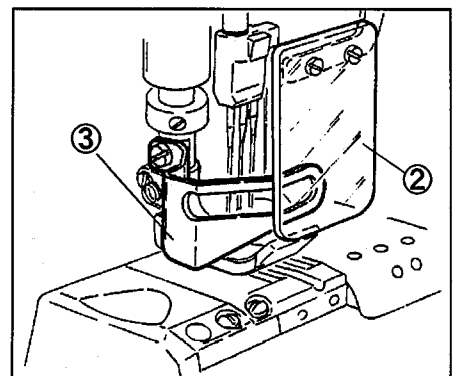



☆ Table top installation (Type B)

A	B	C	D
57	159	66	33

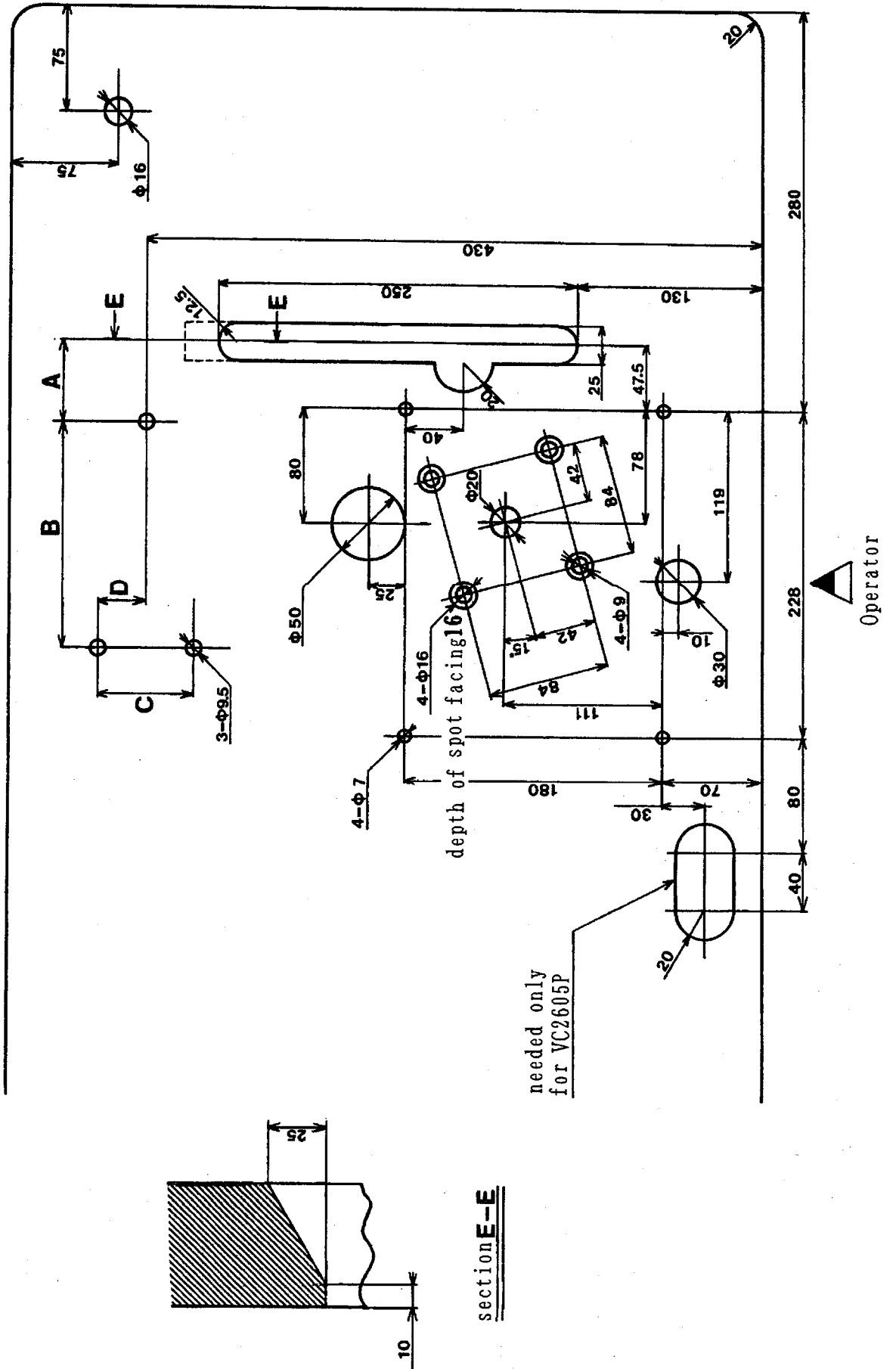

☆ Semi-submerged installation

A	B	C	D
57	159	66	33

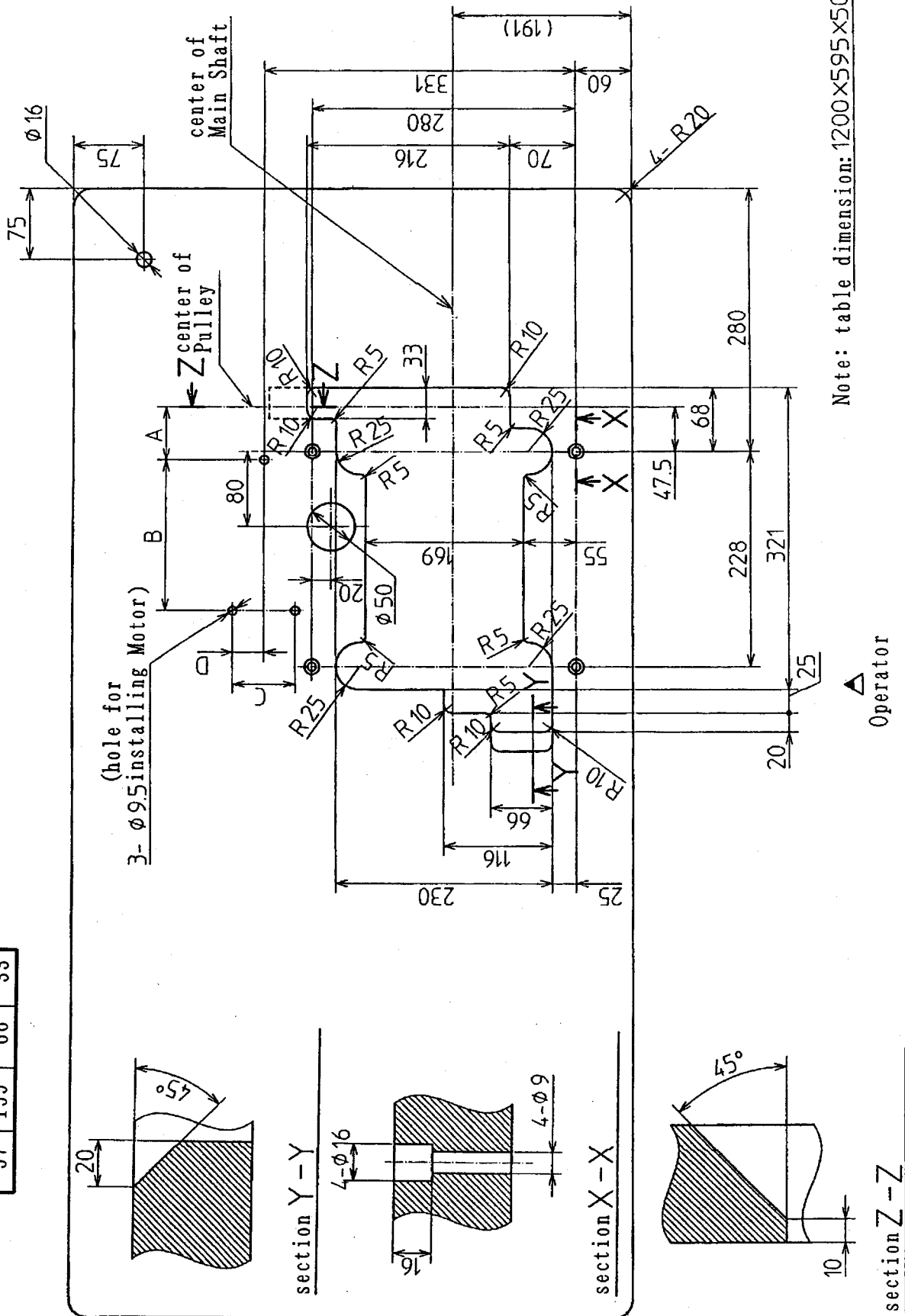

## 2-5 Table top installation

- (1) Fix Nuts and Bolts under the Machine Table.
- (2) Fix Rubber Cushions to Bolts.
- (3) Mount Sewing Machine on them securely.

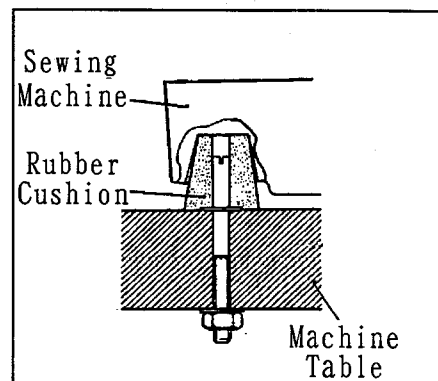

## 2-6 Semi-submerged installation

- (1) Fix Screws to Supporting Board.
- (2) Install Supporting Board to Machine Table.
- (3) Put Rubber Cushions on Screws.
- (4) Mount Sewing Machine on them securely.

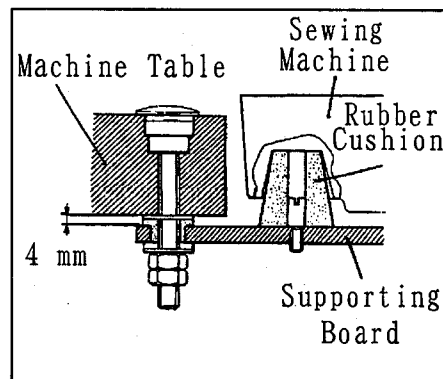

## 3. Sewing Speed and Rotating Direction of Pulley

The max. sewing speed is 4500 s.p.m., and the ordinary speed is 4000 s.p.m.

To ensure long service life, your new Machine should be operated at 3500 s.p.m. during the first 200 hours (about one month), and then at the ordinary speed. Pulley① must be turned clockwise like Handwheel② as shown in figure.

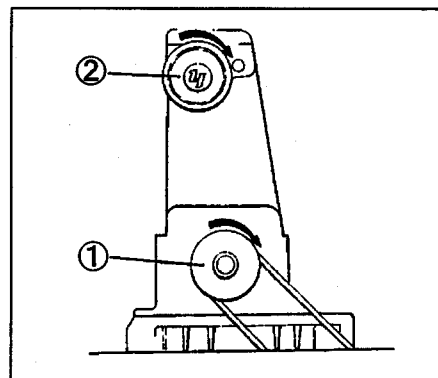

## 4. Motor and Belt

The Clutch Motor of 3-phase, 2-pole, 400 W (1/2 HP) and M-type of V-Belt should be used.

When shifting Motor Pulley to the left by pressing down Pedal, position Motor so that the center of Motor Pulley aligns with that of Machine Pulley.

dia. of Motor Pulley (mm)	s.p.m. of Machine	
	50 Hz	60 Hz
75		4000
80		4200
85		4500
90	4000	
100	4500	

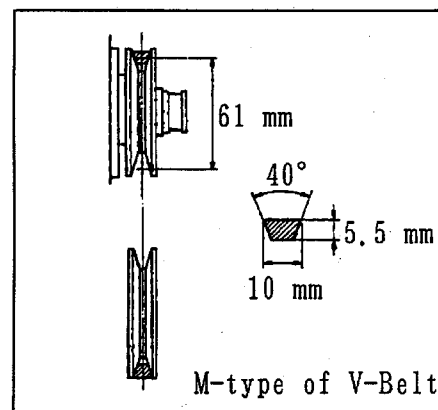

Note: A commercial Pulley is at intervals of 5 mm in diameter. The diameters on the table are the nearest size to the calculated value.



## 5. Lubrication

### 5-1 Supplying oil

- (1) Open Top Cover Seal Plug①.
- (2) Supply YAMATO SF Oil until the upper line of Oil Sight Gauge②.
- (3) Close ①.

Note: While running, check oil splashes from Nozzle with Oil Sight Window③.

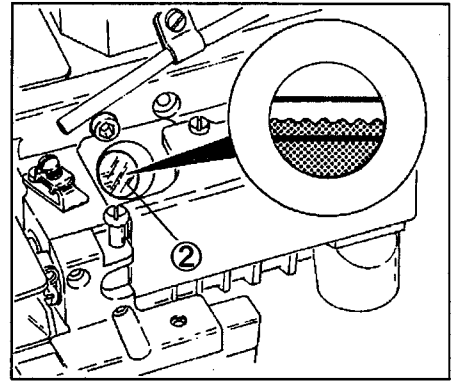
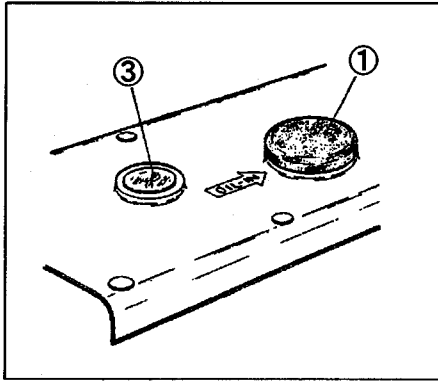

### 5-2 Replacing oil

Oil should be replaced in 250 hours since Sewing Machine began to be operated. After that, oil should be replaced every six months.

- (1) Remove V-Belt from Motor Pulley.
- (2) Remove Sewing Machine to put on Table.
- (3) Open Screw④ to drain away oil.

Note: Take care not to drop Sewing Machine from Table and not to attach oil on V-Belt.

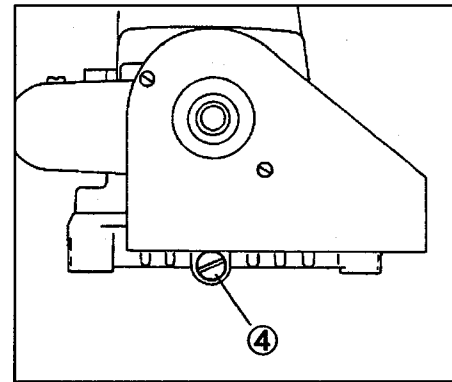

- (4) Close ④.
- (5) Mount Sewing Machine on Table.
- (6) Fit V-Belt to Motor Pulley.
- (7) Supply new YAMATO SF Oil No. 28.

### 5-3 Checking and replacing Oil Filter

When Oil Filter⑤ is clogged with dust, oil will not properly lubricate. It should be checked every six months. Though oil is sufficiently kept, when no or little oil splash from Nozzle, Oil Filter⑤ should be checked. For checking, remove Oil Filter Cap⑥. When clogged with dust, replace with new one.

Note: Take care when removing ⑥, oil on ⑤ may be leaked.

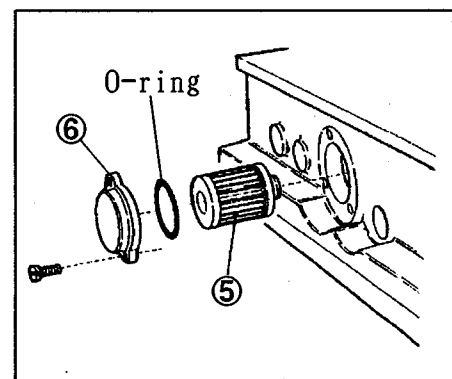

## 5-4 Cleaning Sewing Machine

Waste thread and dust inside of Sewing Machine may cause troubles. Sewing Machine should be cleaned regularly. Grooves of Stitch Plate and area around Feed Dogs should be especially cleaned.

Note: If using air gun, be careful in order to keep free from dust or waste thread on the products.

Note: Do not loosen Positioning Bushing Screws (yellow) ① on Stitch Plate Support.

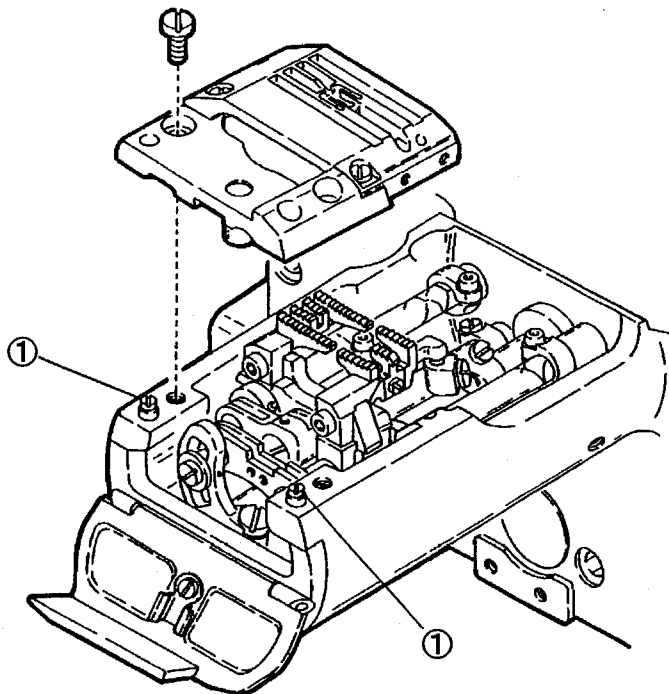

## 6. Proper Operation

### 6-1 Needle system and installing

The Needle to be used is UY×128GAS (UY128GAS). Depending on the thickness and material of the fabric, the proper Needle should be selected.

Japanese size	9	10	11	12	13	14
Metric size	65	70	75	80	85	90

- (1) Loosen Screw.
- (2) Face the scarf of Needle to the right back.
- (3) Insert Needle into Needle Clamp fully.
- (4) Tighten Screw.

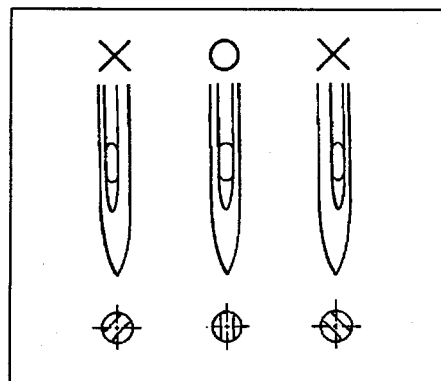

## 6-2 Threading

Needle thread  
Cut off knots just before needle eye to rethread.

- ☆ When had been threaded, knot the preset thread and new one together to rethread.
- ☆ When not threaded, see this Threading Chart to thread correctly.

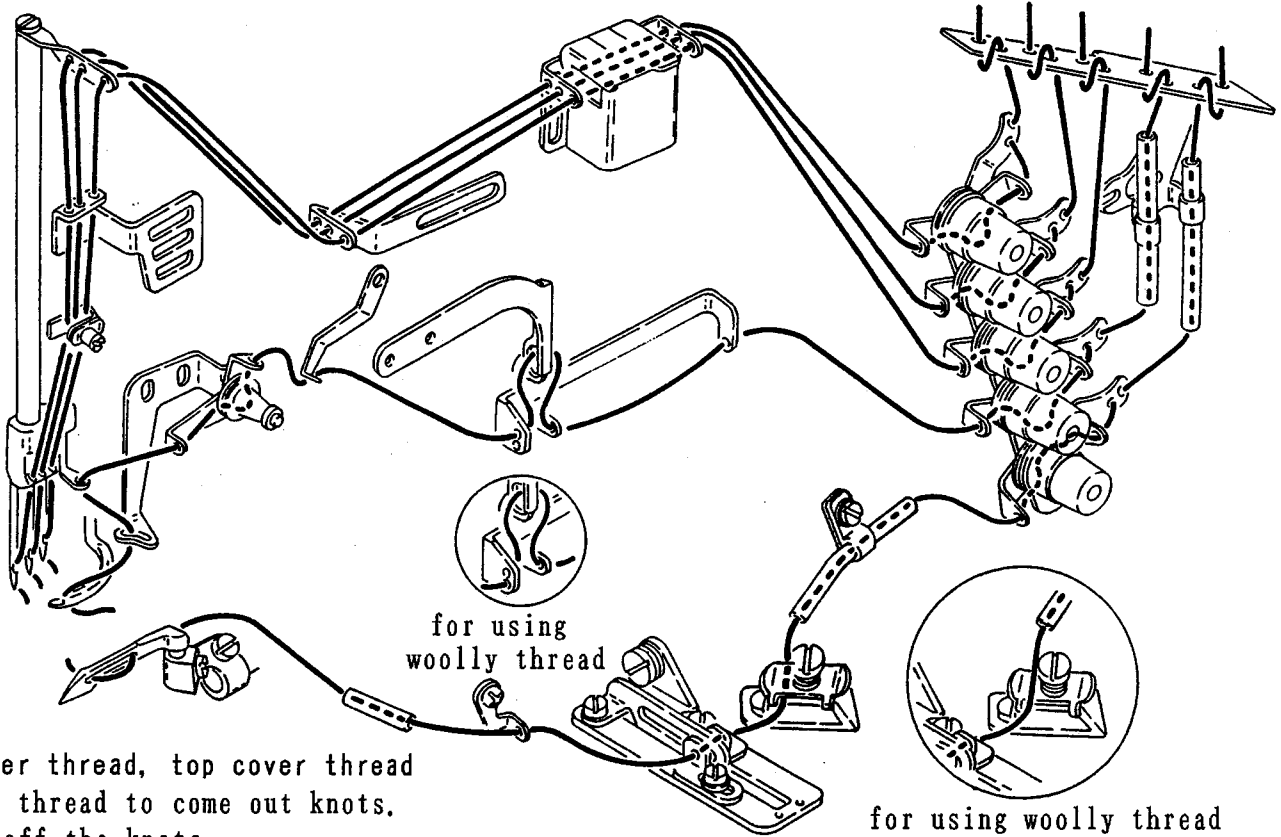

Looper thread, top cover thread  
Pull thread to come out knots.  
Cut off the knots.

for using woolly thread

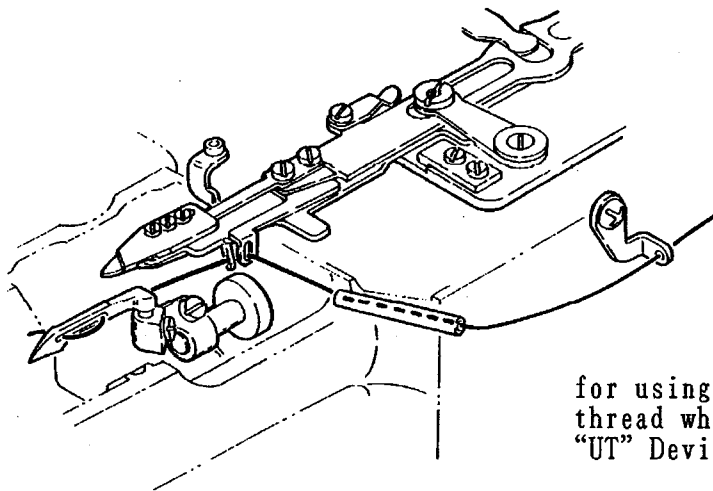

for using woolly thread when operating "UT" Device

### 6-3 Thread tension

According to fabric or thread, thread tension is different. When changing, adjust with Thread Tension Spring Cap.

### 6-4 Presser Foot pressure

The pressure should be minimized so long as stable stitches can be formed.

- (1) Loosen Lock Nut①.
- (2) To increase the pressure, turn Adjusting Screw② clockwise.  
To decrease, turn ② counterclockwise.
- (3) Tighten ①.

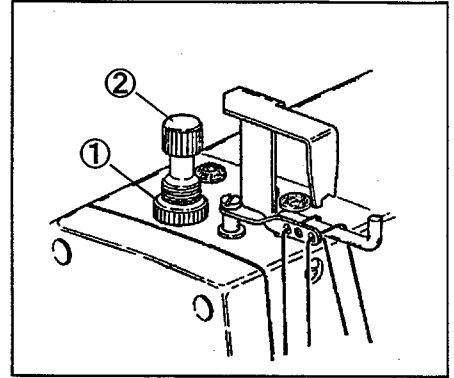

### 6-5 Right-left position of Presser Foot

- (1) Loosen Screw④.
- (2) Move the edge of Presser Foot③ to right and left so that each Needle can drop to the center of needle hole.
- (3) Tighten Screw④.

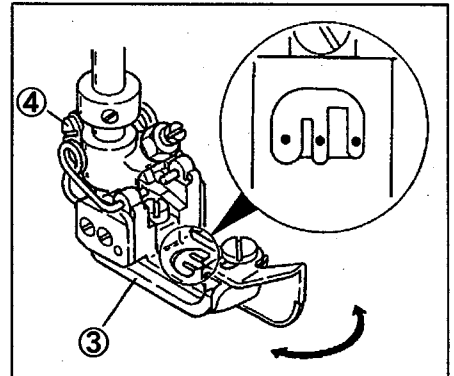

### 6-6 Adjustment for lowering and raising the front of Presser Foot

- (1) For lowering and raising the front (set at the shipment)  
The front can be freely lowered and raised  $0^{\circ} - 5^{\circ}$ .
- (2) For raising the front  
Loosen Lock Nut⑤ and tighten Adjusting Screw⑥.  
The more the Screw⑥ is tightened, the more the front rises.

The front can not be lowered.

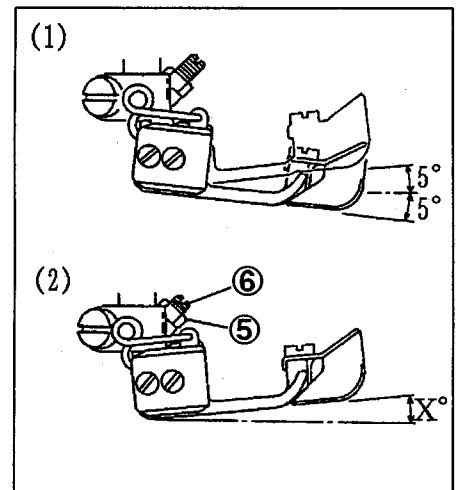

## 6-7 Adjusting stitch length

Stitch length is adjustable 1.4 - 4.2 mm.

- (1) To lengthen, turn Adjusting Knob ⑨ clockwise. Feed Control Lever ⑫ moves downward.
- (2) To shorten, turn ⑨ counterclockwise. ⑫ moves upward.

### ☆ Adjusting with Feed Control Lever

For adjusting stitch length during operation, connect chain to ⑫.

The following table shows the number of stitch per inch and 30 mm.

stitch length (mm)	stitches per	
	inch	30 mm
4.2	6	7.5
3.6	7	8
2.4	10.5	12.5
1.4	18	21

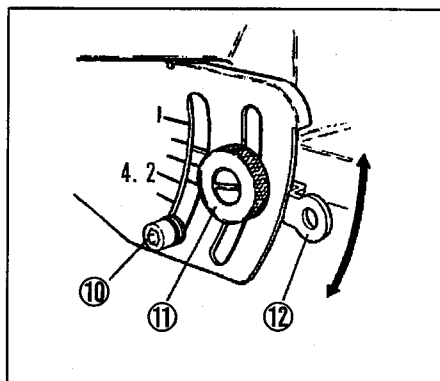
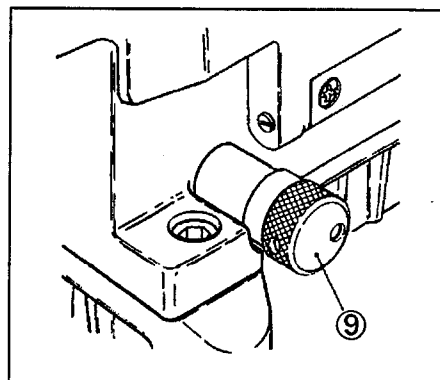

## 6-8 Adjusting differential feed ratio

When aligning the center of Screw ① with the dot ②, the differential ratio is 1 : 1.

- (1) Loosen Screw ①.
- (2) For gather sewing, (max. normal differential feed 1 : 1.4) move ① upward.
- For stretch sewing, (max. reverse differential feed 1 : 0.8) move ① downward.

Note: When stitch length is 4.2 mm, max. normal differential feed ratio is 1 : 1.2.

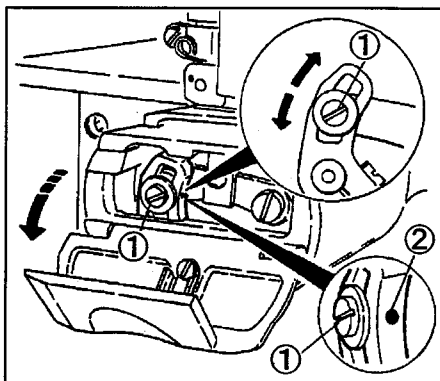

## 6-9 SP Device (for needle thread oiling)

Troubles such as skipping stitch, thread breakage, and material breakage may be caused especially when using synthetic thread or fabric. SP Device prevents needle point from overheating to avoid these troubles. Silicone oil must be used.

- Notes: (1) Sometimes check oil quantity by opening the lid ① of SP Container. When running short, supply it.
- (2) **NEVER** supply silicone oil into Machine. In case spilling it inside of Machine, wipe thoroughly with cloth, because Machine may not run.

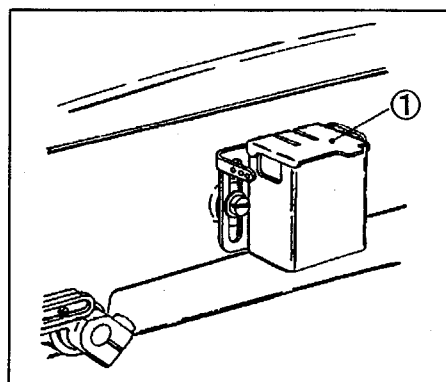

## 7. Adjustment of Sewing Machine

### 7-1 Needle thread tension

The standard distance between the left end of Needle Thread Take-up<sup>①</sup> and the center of Screw<sup>②</sup> (Left) is 57 mm. The standard condition is that the top surface<sup>③</sup> of <sup>①</sup> is level, when Needle Bar is at the top of its travel.

- (1) Loosen Screws<sup>②</sup>.
- (2) To tighten needle thread, slide <sup>①</sup> toward (T).  
To loosen, slide <sup>①</sup> toward (L).
- (3) Tighten Screws<sup>②</sup>.

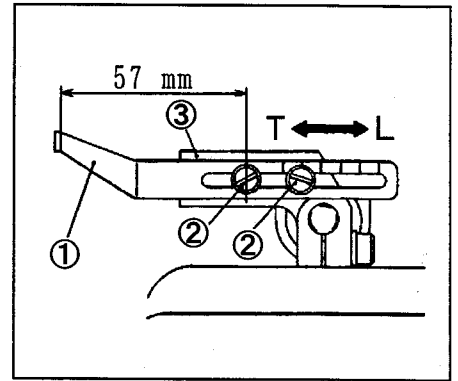

If this adjustment is not effective:

- (1) Loosen Screw<sup>④</sup>
- (2) To tighten, slide <sup>⑤</sup> toward (T).  
To loosen, slide <sup>⑤</sup> toward (L).
- (3) Tighten Screw<sup>④</sup>.

Note: The standard distance is 18 mm between the eye of <sup>⑤</sup> and the center of Screw<sup>④</sup>.

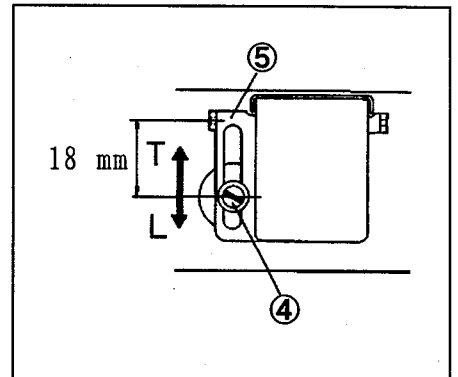

- ☆ According to the kinds of thread, a loop of needle thread may not be formed. Therefore, skipping stitch may be caused, because Loper can not catch a needle thread. To avoid skipping stitch, pass the needle thread through Thread Tension Disc<sup>⑥</sup>.

Note: When operating Sewing Machine with "UT" Device, do not use <sup>⑥</sup>, because stitches may not be formed at the sewing start.

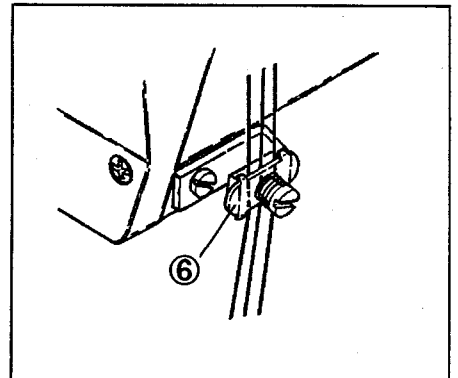

- ☆ When a loop of needle thread can not be formed by using stretchable thread like synthetic thread, Needle Thread Guide should be used.

- (1) Loosen Screw<sup>⑨</sup>.
- (2) The standard condition is that the center of eye of Needle Bar Thread Eyelet<sup>⑦</sup> is the same height with the top surface of Needle Thread Guide<sup>⑧</sup> and <sup>⑦</sup> is parallel with <sup>⑧</sup>, when Needle Bar is at the bottom.
- (3) Tighten Screw<sup>⑨</sup>.

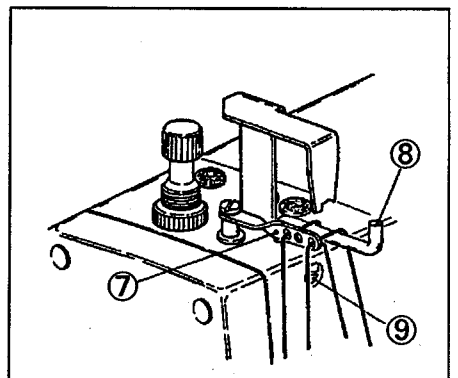

### 7-2 Top cover thread tension

- (1) To decrease the feed of thread, raise Top Cover Thread Eyelet(Right)① toward (X).
- (2) To increase, lower ① toward (Y).

Notes: (1) When using stretchable thread like woolly, loosen Screw② to lower ① toward (Y).  
(2) When using woolly thread, thread the lower eye.

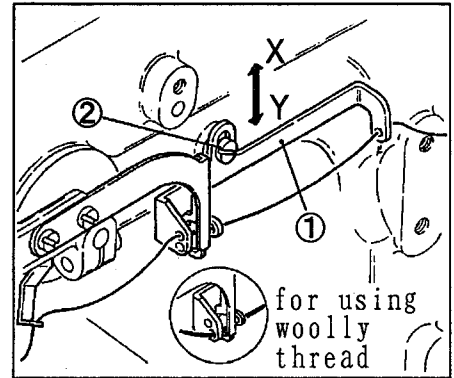

### 7-3 Loper thread tension

The standard is that the eyes of Thread Eyelet⑤ and ⑥ are aligned with the mark(-)④ on Loper Thread Take-up Eyelet Support③.

- (1) To increase the feed of thread, loosen Screws in ⑤ and ⑥ to slide ⑤ and ⑥ toward the operator side.
- (2) To decrease, slide ⑤ and ⑥ toward the opposite side to the operator.

Notes: (1) Too much feed of looper thread may cause skipping stitch.  
(2) For woolly thread, slide ⑤ and ⑥ toward the operator fully.  
Do not thread Thread Tension Disc⑦.

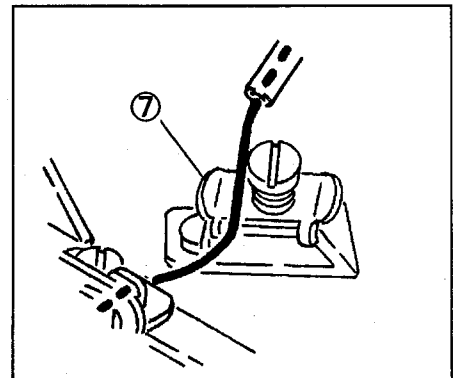
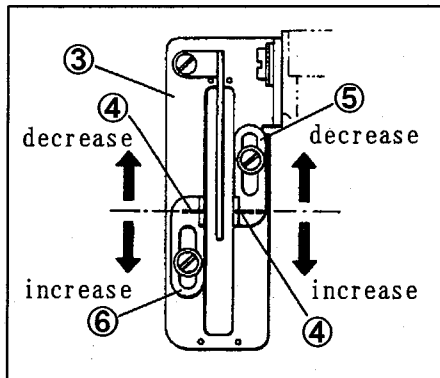

### 7-4 Position of Loper Thread Take-up

Looper Thread Take-up seen from Needle Bar side is shown below at left.

- (1) Loosen Screws⑨.
- (2) When the left Needle reaches at the half of Loper by lowering Needle Bar as shown at right, adjust so that thread is taken off at the highest point of Loper Thread Take-up⑧.
- (3) Tighten Screws⑨.

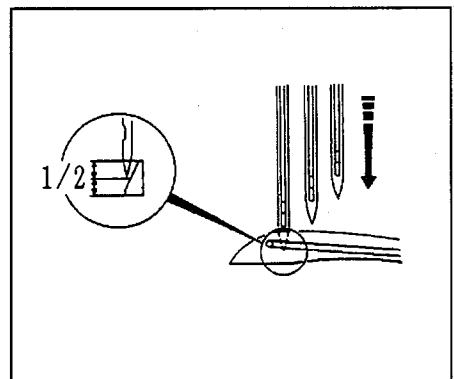
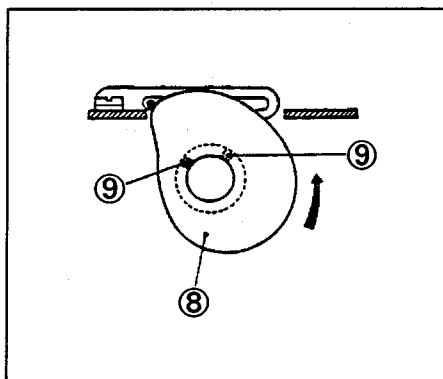

### 7-5 Removing Presser Foot and Presser Foot lift

To remove:

- (1) Loosen Screw② of Lifter Lever Stop① and Screws④ of Collar③.
- (2) Press down Lifter Lever⑤.

To adjust Presser Foot lift:

- (1) Press down ⑤ to make a space of 5.0 mm (for using Spreader⑦) between Stitch Plate and Presser Foot.

Notes: (1) Without using ⑦, make a space of 7.0 mm.  
(2) Without using ⑦, Collar is not used.

- (2) Tighten Screw②.
- (3) Make a space of 0.2 mm between Presser Bar Bushing⑥ and ③.
- (4) Tighten Screws④.

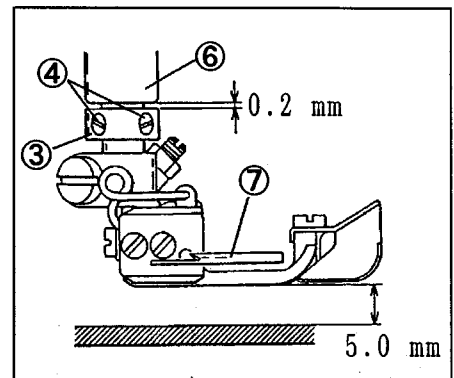
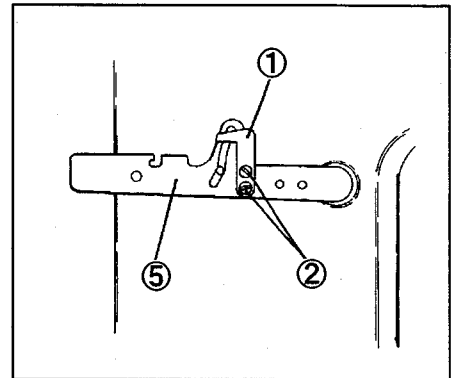

### 7-6 Relation between Needle and Stitch Plate

After adjusting the height of Needle Bar or replacing Needle Clamp or the like, Needles must be correctly aligned as shown by solid line. Take care not to be in the condition as shown by dotted line.

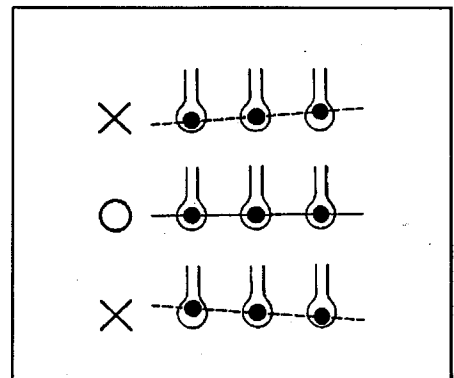

### 7-7 Angle and height of Loper

- (1) Insert Loper into Loper Holder① fully.
- (2) Tighten Screw②.
- (3) The angle of 2° and the height are set accordingly.

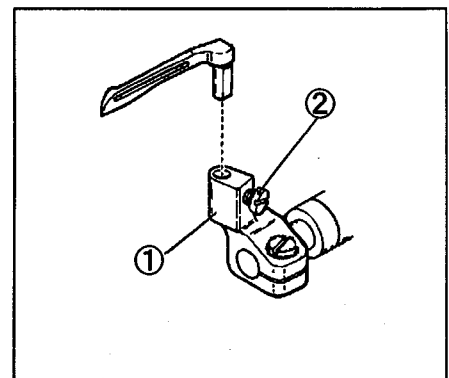



### 7-8 Distance between Needle and Loper

When Needles are at the bottom of their travel and Loper is at the rightmost position, the distance (M) is made between the center line of the right Needle and the Loper point. According to the needle distance, the distance (M) is different. See the following table.

(1) To adjust, loosen Screw③ of Loper Holder.

Note: Even when the needle distance is different, the distance between the center of Needle Bar and the Loper point is 6 mm.

Needle distance (mm) (Mark)	Distance (M) (mm)
3.2 (A)	4.4
4.0 (B)	4.0
4.8 (C)	3.6
5.6 (D)	3.2
6.4 (E)	2.8

☆ For easy adjustment of the distance (M), Timing Gauge (#95220) should be used. Timing Gauge is an extra part. Please place an order with our agents or directly with us, if required.

### 7-9 Using Timing Gauge

Timing Gauge has the marks (A, B, C, D, E) for each needle distance.

- (1) Loosen Screw③ of Loper Holder.
- (2) When Loper is at the rightmost, fit the corresponding "V" groove of Timing Gauge into the right Needle to fit the Loper point to Timing Gauge.
- (3) Tighten Screw③.

### 7-10 Height of Needle Bar

- Notes: (1) Needle must be inserted into Needle Clamp fully to be screwed.  
 (2) Loper must be inserted into Loper Holder fully to be screwed.

The height of Needle is fixed on the basis of Loper. When the Loper point is at the center of the left Needle, the height of Loper must be 0.5 - 1.0 mm above the needle eye.

To adjust:

- (1) Insert a screwdriver into the hole④ of Head Cover.
- (2) Loosen Screw⑤ of Needle Bar Bracket.
- (3) Move Needle Bar up and down to adjust the height.
- (4) Tighten Screw⑤.

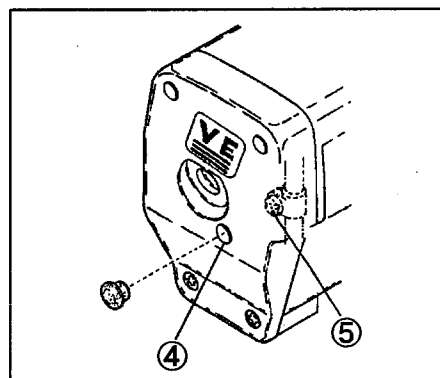
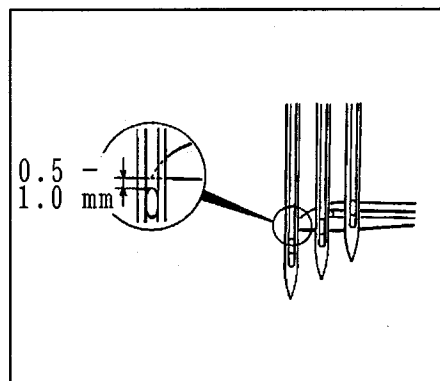
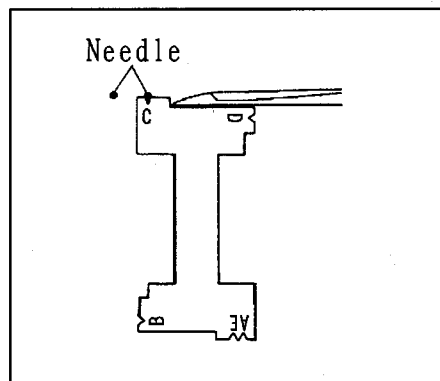
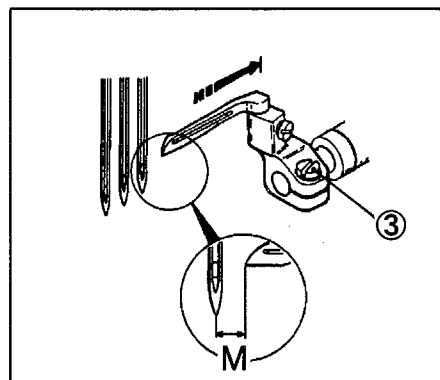
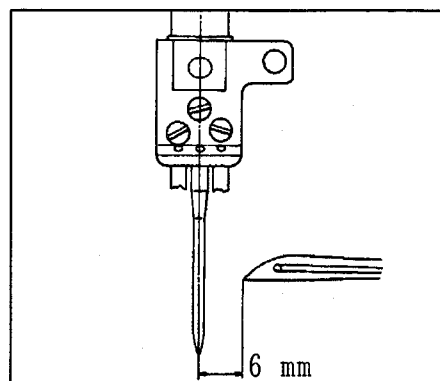

## 7-11 Longitudinal position of Needle and Looper

☆ For three Needles

- (1) Loosen Screw⑥ of Looper Holder.
- (2) When the Looper point③ meets Needle④, make a space of 0.2 - 0.3 mm.
- (3) Tighten Screw⑥.

☆ For two Needles

- (1) Loosen Screw⑥ of Looper Holder.
- (2) When the Looper point③ meets the left Needle⑤, make a space of 0.2 - 0.3 mm.
- (3) Tighten Screw⑥.

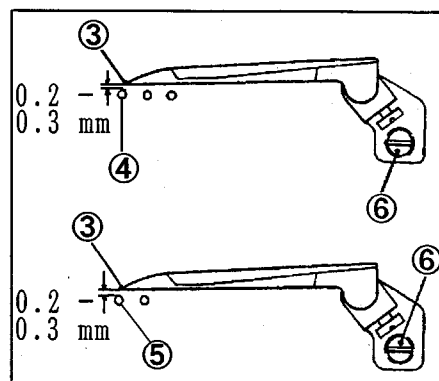

## 7-12 Needle and Needle Guard(Rear)

☆ Height of Needle Guard(Rear)

When Needle Bar is at the bottom of its travel, align the line⑧ on Needle Guard(Rear)⑦ with the center of needle eye of the right Needle.

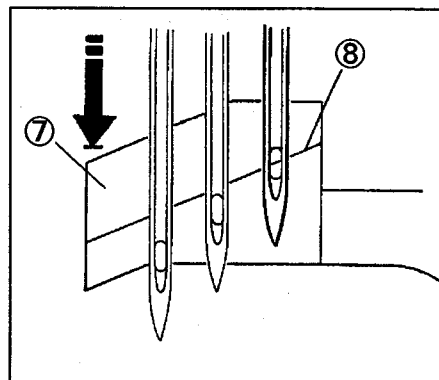

☆ Height of Needle Guard(Rear)

(for using VE2711-□□□S-1)

When Needle Bar is at the bottom of its travel, align the line⑧ on Needle Guard(Rear)⑦ with the bottom of needle eye of the right Needle.

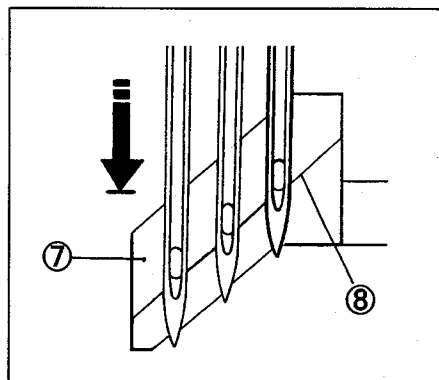

☆ Longitudinal position of Needle Guard(Rear)

- (1) Loosen Screws⑨ and ⑩.
- (2) When the Looper point meets the center of the right Needle, touch Needle Guard(Rear) to Needle so that a space is 0 - 0.05 mm between Needle and Looper.
- (3) Make a space of 0 - 0.05 mm between the left Needle and Needle Guard(Rear).
- (4) Tighten Screws⑨ and ⑩.

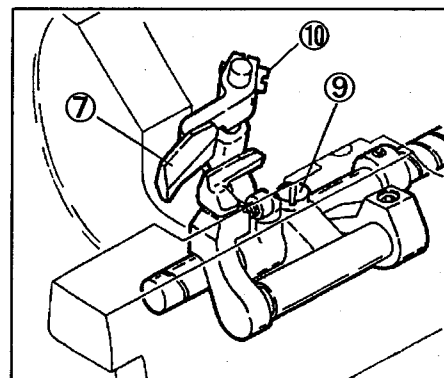
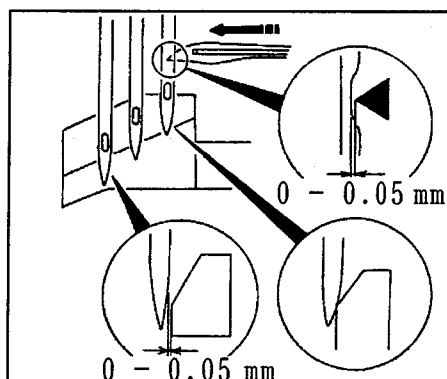

### 7-13 Needle and Needle Guard(Front)

- (1) Loosen Screws⑫ and ⑬.
- (2) When the Looper point is at the center of the left Needle, make a distance of 1.5 - 2.0 mm between the Needle point and the angular part⑭ of Needle Guard(Front)⑪.
- (3) Make a space of 0 - 0.3 mm between the Needle and ⑪.
- (4) When the Looper point is at the right Needle, make a space of 0 - 0.3 mm between the Needle and ⑪.
- (5) Tighten Screws⑫ and ⑬.

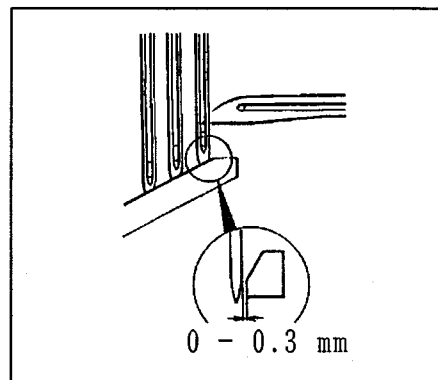
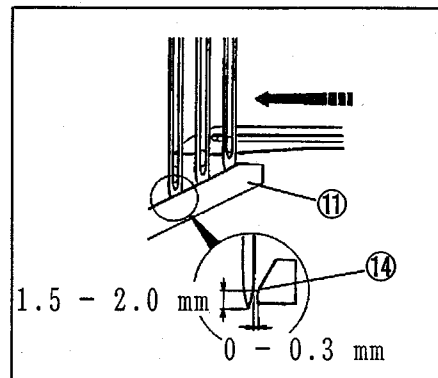
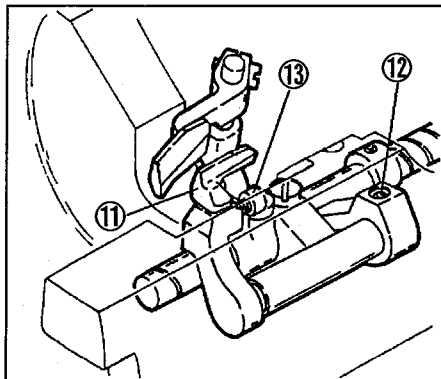

### 7-14 Height of Feed Dog

At the shipment, when Feed Dog is at the top position, the top surface of Feed Dog and Stitch Plate is level.

For normal sewing:

- (1) Loosen Screws③ and ④.
- (2) Set the height of Differential Feed Dog① and Main Feed Dog② to the same.
- (3) Make a distance of 1.0 - 1.2 mm from the top surface of Stitch Plate to that of Feed Dog.
- (4) Tighten Screws③ and ④.

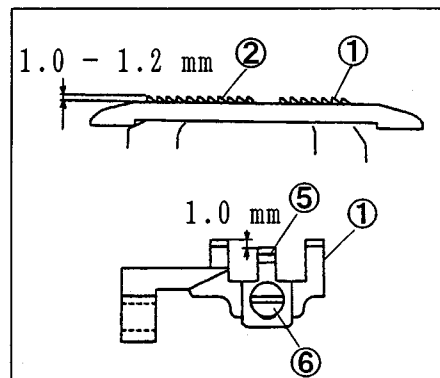

### ☆ Adjusting Differential Feed Dog(Middle)

Loosen Screw⑥ to adjust Differential Feed Dog (Middle)⑤.

The standard height is 1.0 mm below Differential Feed Dog①.

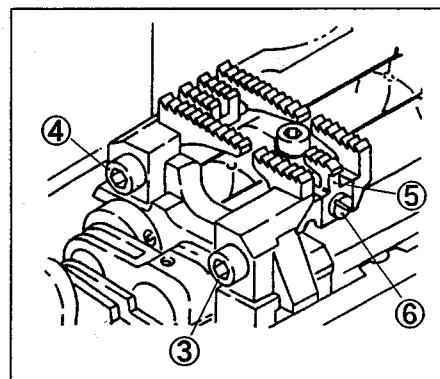

## 7-15 Needle and Spreader

### ☆ Installing Spreader

- (1) Loosen Screws ③ and ④ to make a space of 0.5 - 0.8 mm between the left Needle and the hook ② of Spreader ①.
- (2) When reaching ① to the leftmost, loosen ③ and ④ to make a distance of 4.5 - 5.5 mm from ② to the center line of the left Needle.
- (3) Loosen ③ to make a height adjustment from Stitch Plate to ① as shown in the following figures.

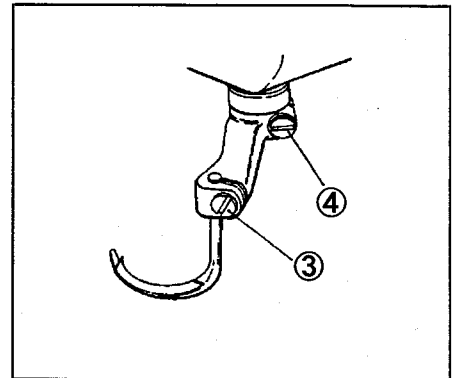
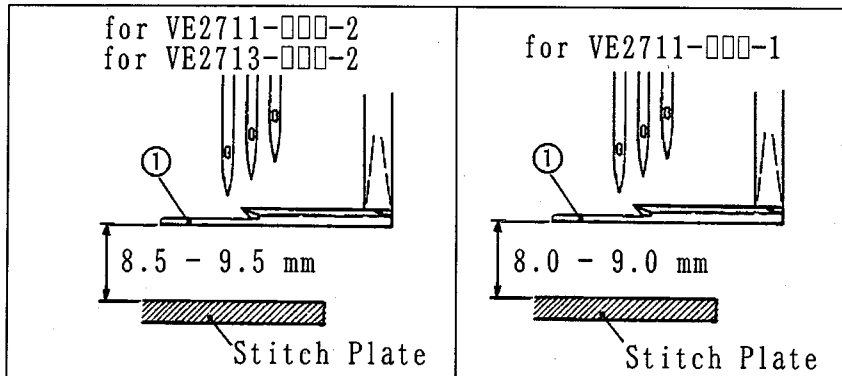
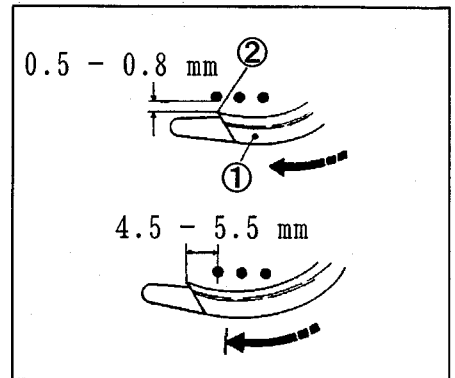

### ☆ Installing Top Cover Thread Guide

- (1) Loosen Screws ⑥ to make a space of 0.5 mm between Top Cover Thread Guide ⑤ and ①.
- (2) When reaching ① to the rightmost (at the position that thread can be hooked smoothly), tighten ⑥.

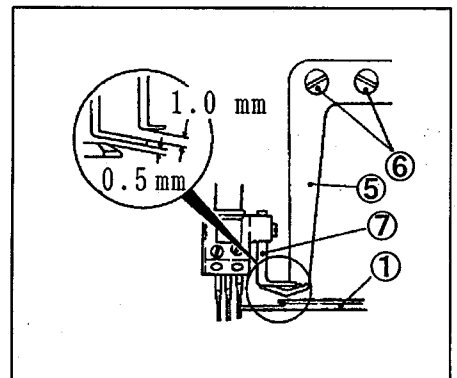

### ☆ Installing Top Cover Thread Eyelet

- (1) Loosen Screw ⑧.
- (2) When Needle Bar is at the bottom of its travel, make a space of 1.0 mm between ⑤ and Top Cover Thread Eyelet ⑦.
- (3) Position the eye of ⑦ on the prolongation of slot of ⑤.
- (4) Tighten ⑧.

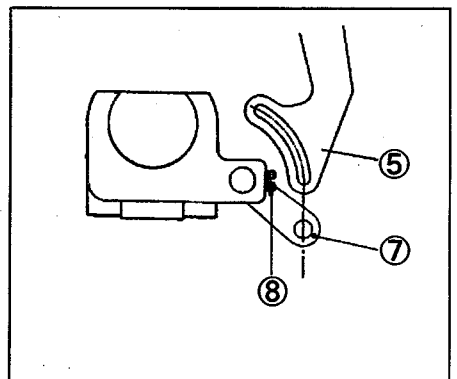

## 8. Adjustment of Puller Mechanism

### 8-1 Position of Upper Feed Roller

The teeth of Upper Feed Roller must be parallel to that of Lower Feed Roller. And when Upper Feed Roller is lowered, the clearance between Upper and Lower Feed Roller must be 0.5mm. That the standard.

\* Adjust the teeth of Upper and Lower Feed Roller to be parallel with each other. The adjustment is made by loosening Screw(A) of Upper Feed Roller Holder, Screw(B) of Yoke Guide and Screw(C) of Yoke Pin.

After positioning using Screws(A) and (B), make sure that it can be moved lightly up and down, then tighten Screw(C).

\* Provide a clearance of about 0.5mm between Upper and Lower Feed Roller. When Upper Feed Roller is lowered, the adjustment is made by loosening Nut(D) and using Adjusting Screw(E). Adjust the clearance according to the thickness of fabric.

\* Provide a clearance of 0.5mm between under-surface of slot in Lifter Connecting Plate(F) and Screw(G) when Presser Foot rests on the surface of Stitch Plate. The adjustment is made by loosening Screw(H) of Upper Feed Roller Lifter(Right).

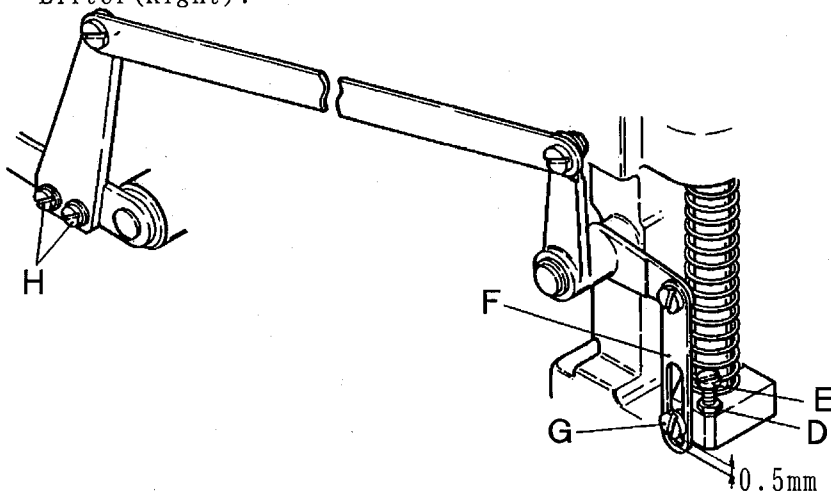
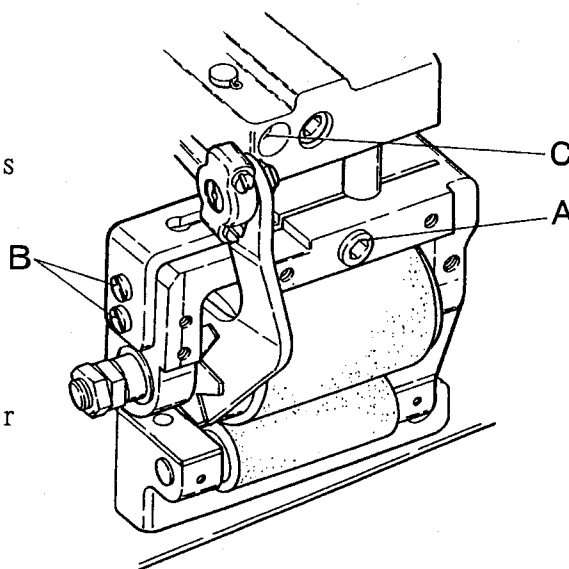
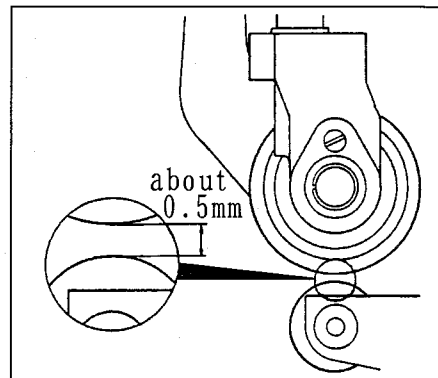

### 8-2 Pressure of Upper Feed Roller

Set the pressure to the minimum necessary for feed, holding fabric between Upper and Lower Feed Roller. To increase the pressure, turn Adjusting Screw(I) clockwise and to decrease the pressure, turn it counterclockwise.

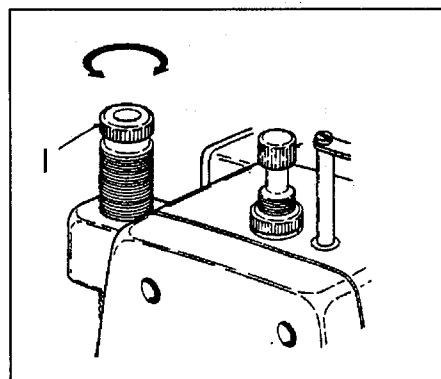

### 8-3 Adjustment of feed amount of Puller

The adjustment of feed amount should be made following the next procedure:

- ① Remove Seal Plug(A) from Top Cover.
- ② Turn Handwheel until Screw(B) of Main Feed Eccentric appears in the window, then loosen Screw(B).
- ③ Turn Handwheel until Adjusting Screw(C) appears in the window.
- ④ To increase the feed amount of Puller, turn Adjusting Screw(C) counterclockwise and to decrease, turn it clockwise.
- ⑤ Tighten Screw(B) of Main Feed Eccentric. Use attached hexagonal key wrench screwdriver. (tightening torque : 25 kgf·cm)  
For micro-adjustment of feed amount, loosen Nut(F) of Upper Feed Roller Lever Rod(E) fixed on Upper Feed Roller Lever(D) and move Rod (E) upward to decrease the feed amount or move it downward to decrease.

Note : Feed oil to 2 Oil Hole of Upper Feed Roller Lever Rod(E) before operation.

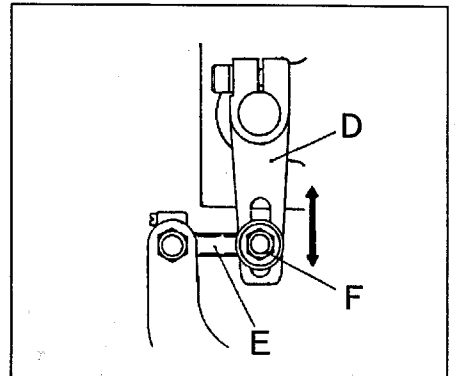
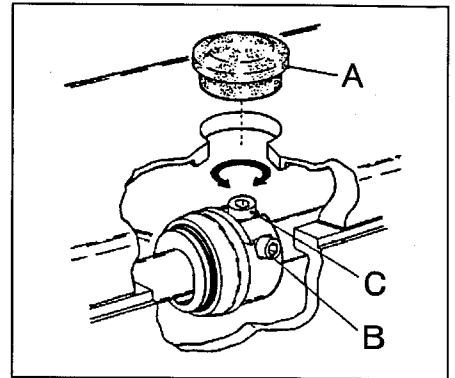

### 8-4 Adjustment of lifting amount of Upper Feed Roller

Upper Feed Roller(G) has been adjusted to rise 8mm above the circumference of Lower Feed Roller(I) when Upper Feed Roller Lifting lever(H) is pulled forward. Readjustment of lifting amount of Upper Feed Roller should be made following the next procedure:

- ① Bring down Upper Feed Roller Lifting Lever(H).
- ② Loosen Screw(J) of Roller Press Bar Bracket.
- ③ Engage Upper Feed Roller(G) and Lower Feed Roller(I) providing a little clearance between them.  
(Change the clearance according to the thickness of fabric.)
- ④ Tentatively set Lifting Lever Sleeve(K) fixed on Roller Press Bar Bracket to the portion(h) of Upper Feed Roller Lifting Lever with a little clearance with Screw(J).
- ⑤ Turn Stop Screw(L) of Upper Feed Roller, keep touching to the Arm tighten Lock Nut(M).
- ⑥ Make sure that Upper Feed Roller(G) is 8mm above the circumference of Lower Feed Roller(I), when Upper Feed Roller(G) is raised by pulling Upper Feed Roller Lifting Lever. Then tighten Screw(J).

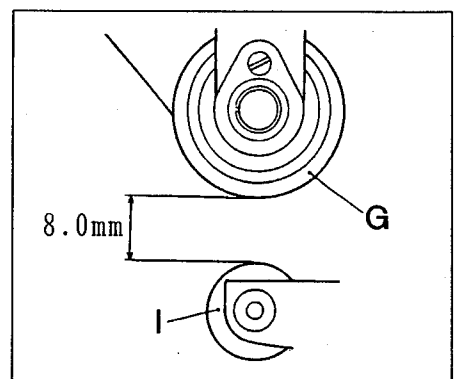
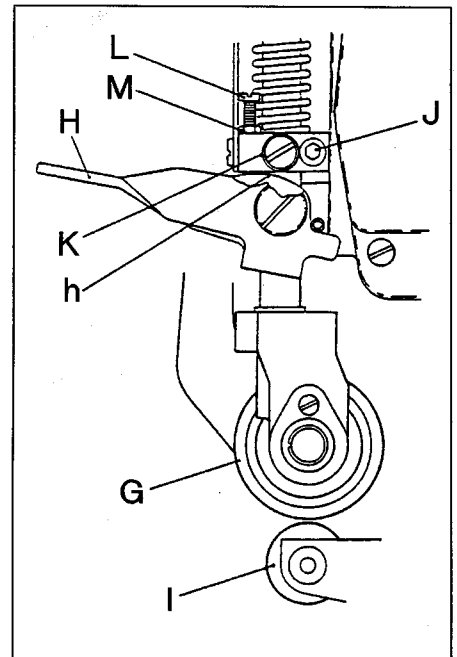

***Yamato***

ヤマトマシン製造株式会社

***YAMATO SEWING MACHINE MFG. CO., LTD.***

4-4-12, NISHITENMA, KITA-KU, OSAKA, JAPAN  
TEL : 81-6-6364-1321 FAX : 81-6-6364-1307

〒530-0047 大阪市北区西天満4丁目4番12号  
TEL(06)6364-1321(代) FAX(06)6365-5176