

# ***Yamato***<sup>®</sup>

## Instruction Manual

HIGH SPEED CYLINDER BED MULTI-NEEDLE MACHINE WITH PULLER  
WITH UNDER THREAD TRIMMER AND FOLDER SLIDER

**VC2840P/UT-A50**  
**VC2845P/UT-A50/AS4**

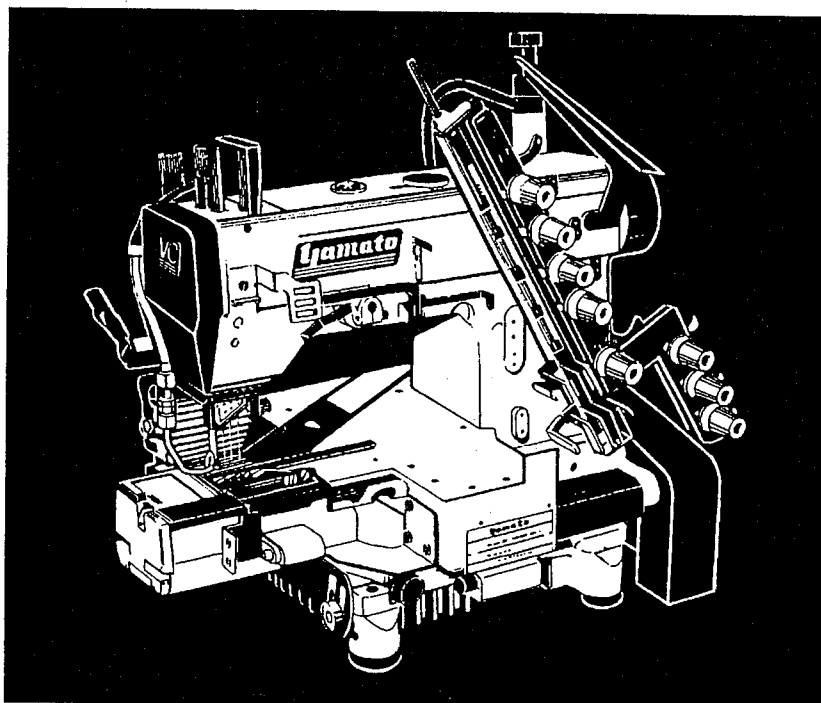

Thank you for having purchased this machine.  
Before using your machine, please read this instruction manual and understand the contents well.  
After reading this instruction manual, please keep it in a location where it is easy to access for operators.



ヤマトマシン製造株式会社

# CONTENTS

	Page
1. Specifications . . . . .	1
2. Indication of Model Plate . . . . .	2
3. Installation . . . . .	4
3-1 Drawing of table top cut-out . . . . .	4
3-2 Table top installation . . . . .	5
3-3 Fixing Belt Cover . . . . .	5
4. Sewing speed and rotating direction . . . . .	5
5. Motor and Belt . . . . .	6
6. Lubrication oil . . . . .	6
6-1 Lubrication oil . . . . .	6
6-2 Feeding of oil . . . . .	6
6-3 Oil Sight Gauge and Nozzle . . . . .	6
6-4 Oil change . . . . .	7
6-5 Check and change of Oil Filter . . . . .	7
6-6 Cleaning of machine . . . . .	7
6-7 Oiling Take-up Shaft Bracket . . . . .	7
7. Air piping and Suction Pipe . . . . .	8
7-1 Air piping diagram . . . . .	8
7-2 Adjustment of Speed Controller . . . . .	10
8. Proper operation . . . . .	11
8-1 Needles to be used and their setting . . . . .	11
8-2 Threading . . . . .	11
8-3 Pressure of Presser Foot . . . . .	12
8-4 Adjustment of Presser Foot . . . . .	12
8-5 Adjustment of stitch length . . . . .	12
9. Adjustment of sewing machine . . . . .	13
9-1 Needle thread tension . . . . .	13
9-2 Looper thread tension . . . . .	13
9-3 Position of Looper Thread Take-up . . . . .	14
9-4 Removing Presser Foot and its lift amount . . . . .	14
9-5 Relation between Needle and Stitch Plate . . . . .	14
9-6 Removing Stitch Plate . . . . .	14
9-7 Setting angle of Loopers and their height . . . . .	15
9-8 Height of Feed Dog . . . . .	15
10. In case of needle line-up style "X" . . . . .	16
10-1 Timing between Needle and Looper . . . . .	16
10-2 Amount of Looper movement to the right . . . . .	16
10-3 Height of Needle Bar . . . . .	17
10-4 Relation between lengthwise positions of Needle and Looper . . . . .	17
10-5 Needle and Needle Guard(Rear) . . . . .	18
11. In case of needle line-up style "W" and "Y" . . . . .	19
11-1 Timing between Needle and Looper . . . . .	19
11-2 Amount of Looper movement to the right . . . . .	19
11-3 How to use Looper Timing Gauge . . . . .	19
11-4 Height of Needle Bar . . . . .	20
11-5 Relation between lengthwise positions of Needle and Looper . . . . .	20
11-6 Needle and Needle Guard(Rear) . . . . .	21
11-7 Needle and Needle Guard(Front) . . . . .	21

1 2.	Adjustment of Tension Rollers and Folder . . . . .	22
12-1	Setting of Tension Rollers . . . . .	22
12-2	Procedure of sewing (in case of VC2845P-254-X02D/UT-A50/AS4) . . . . .	23
12-3	Adjustment of Tension Rollers . . . . .	23
12-4	Adjustment of Folder . . . . .	24
1 3.	Adjustment of Puller Mechanism . . . . .	25
13-1	Position of Upper Feed Roller . . . . .	25
13-2	Pressure of Upper Feed Roller . . . . .	25
13-3	Adjustment of feed amount of Puller . . . . .	26
13-4	Adjustment of lifting amount of Upper Feed Roller . . . . .	26

“UT-A50/AS4” Device

1 4.	Operation . . . . .	27
1 5.	Connections of Electromagnetic Valve and Safety Switch . . . . .	27
1 6.	Installation of Synchronizer . . . . .	28
1 7.	Adjustment of Trimming Cylinder . . . . .	29
17-1	Installation of Plunger Connecting Rod . . . . .	29
17-2	Stroke of Air Cylinder . . . . .	29
17-3	Adjustment of Cylinder Returning Spring . . . . .	29
1 8.	Adjustment of Automatic Thread Trimmer . . . . .	30
18-1	Position of Upper Knife Carrier . . . . .	30
18-2	Position of each Lower Knife Carrier . . . . .	30
18-3	Position of tip of Lower Knife . . . . .	30
18-4	Relation between Lower Knife and Needle . . . . .	31
18-5	Relation between Upper Knife and Lower Knife . . . . .	31
18-6	Engagement of Upper Knife and Lower Knife . . . . .	31
18-7	Position of Looper Thread Clamp Spring and Thread Clamp . . . . .	32
18-8	Pressure of Looper Thread Clamp Spring . . . . .	32
18-9	Relation between Lower Knife and needle thread, and looper thread . . . . .	32
1 9.	Adjustment of Tension Release Mechanism . . . . .	33
19-1	Tension Release Block . . . . .	33
19-2	Tension Release Lever . . . . .	33
19-3	Tension Disc Separator . . . . .	33
19-4	Thread Pull-off Hook . . . . .	33
2 0.	Adjustment of Air Wiper . . . . .	34
2 1.	Adjustment of Presser Foot Lifter Device . . . . .	34
2 2.	“AS4” Device . . . . .	35
2 3.	“AR10” Device . . . . .	35
23-1	Air piping and wiring . . . . .	35
23-2	Illustration for installing AR11 and AR12 Device . . . . .	36

## 1. Specifications

Description	: High speed multi needle cylinder bed sewing machine with Puller Mechanism for attaching elastic tape to the waist
Dimensions	: Length 490 mm Width 315 mm Height 485 mm Circumference of bed 400 mm (Lower Feed Roller and Folder not included)
Weight	: 42 kg
Stitch type	: ISO (401·401·401·401), (406·401·401·401) and others
Application	: Attaching elastic tape to medium heavy knitted material and elastic tape to the waist of briefs and others
Sewing speed	: Max. 4,000 s.p.m.
Stitch length	: 1.4~5.0 mm      stitch number 5~18 stitch/inch 6~21 stitch/30 mm
Needle to be used	: Schmetz or Organ TV×5 #80~#100 (standard #90)
Needle stroke	: 33 mm
Upper Knife stroke	: 6.0~10.0 mm, adjustable by Lever
Chip suction mode	: by air (Venturi system) (standard) or by vacuum (optional)
Presser Foot lift	: Max. 8.0 mm
Feed regulation	: by Adjusting Knob or by Lever
Differential ratio	: no differential feed (plain feeding)
Lubrication	: Automatic lubrication by Oil Pump (combined use with splash lubrication)
Lubrication Oil	: YAMATO SF OIL
Capacity of Oil Reservoir	: 1,000 cc
Installation	: table top installation





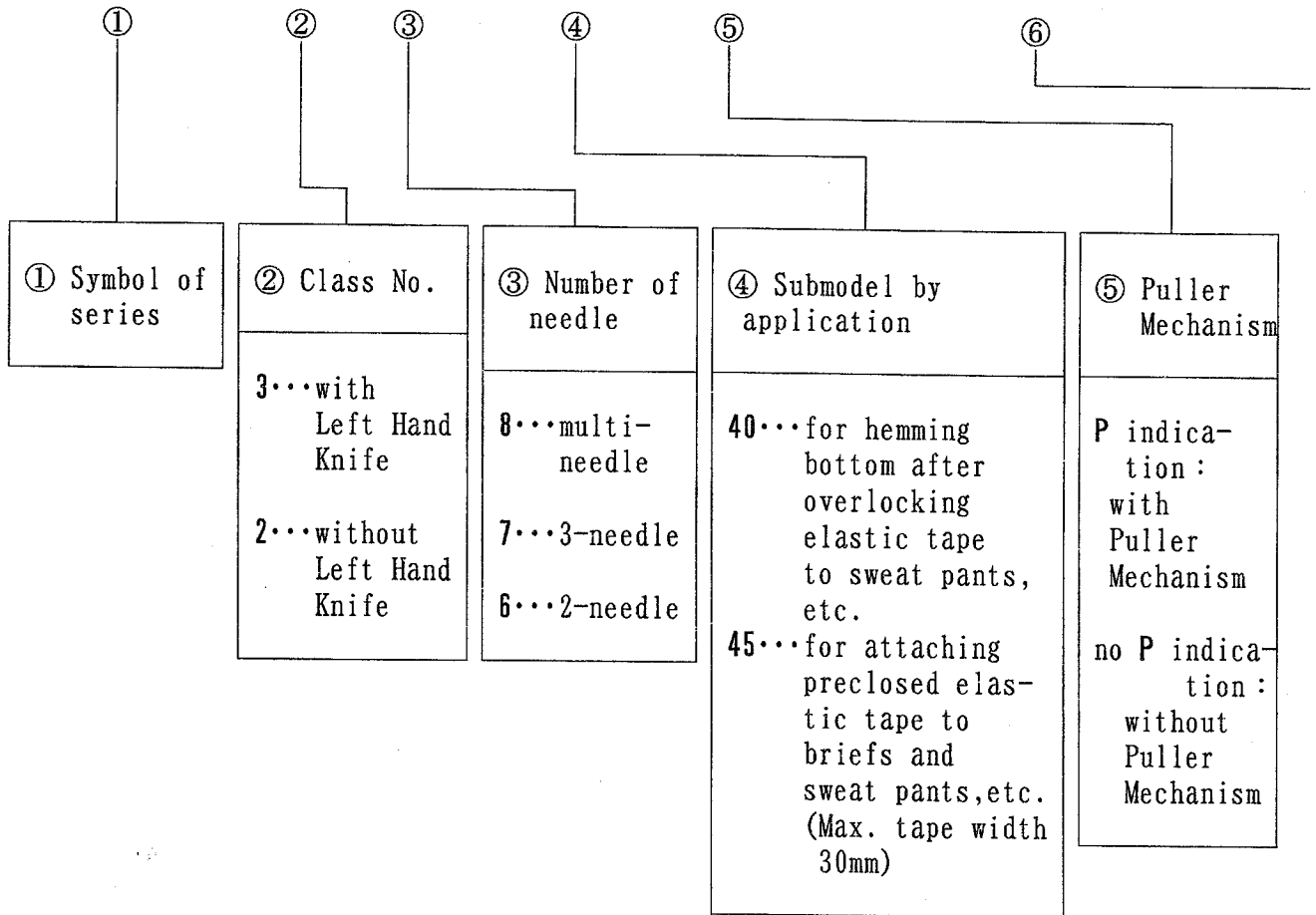

## 2. Indication of Model Plate

(example)

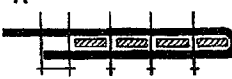
V C 2 8 4 0 P - 2 5 4

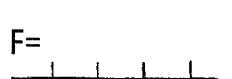

- X 0 2 B / U T - A 5 0 / ( A S 4 )

⑥ Total needle distance	⑦ Needle line-up style	⑧ Needle pitch	⑨ Seam style	⑩ Attachment
381···38.1 mm 340···34.0 mm 308···30.8 mm 303···30.3 mm 300···30.0 mm 296···29.6 mm 266···26.6 mm 256···25.6 mm 254···25.4 mm 192···19.2 mm	W···      X···      Y···      Z···not determined	01=4.8-10-10-10 02=8.5-8.5-8.5 03=4.8-10-4.0 04=4.0-10-3.2 05=4.8-13-13 06=4.0-10-10-10 07=6.4-6.4-6.4-6.4 08=6.4-7.2-7.2-7.2 09=4.8-8.5-8.5-8.5 11=4.8-17-4.8 12=12.7-12.7-12.7 13=6.4-6.4-6.4 14=5.6-10-4.0 15=6.4-12.8-6.4 16=4.8-20-4.8 17=4.0-13-13	A=  B=  C=  D=  E=  F=  G=  Note: B= elastic tape is overlapped at the previous processing	UT-A50: Air operated Automatic Thread Trimmer  UT-A60: A combination of "UT-A50" Device and "AR10" Device  AR10: A combination of "AR11" Device and "AR12" Device  AR11: Air Operated Rear Tension Roller  AR12: Air Operated Lower Tension Roller  AS4: Pneumatic Folder Slider

### 3. Installation

#### 3-1 Drawing of table top cut-out

\* Table top installation

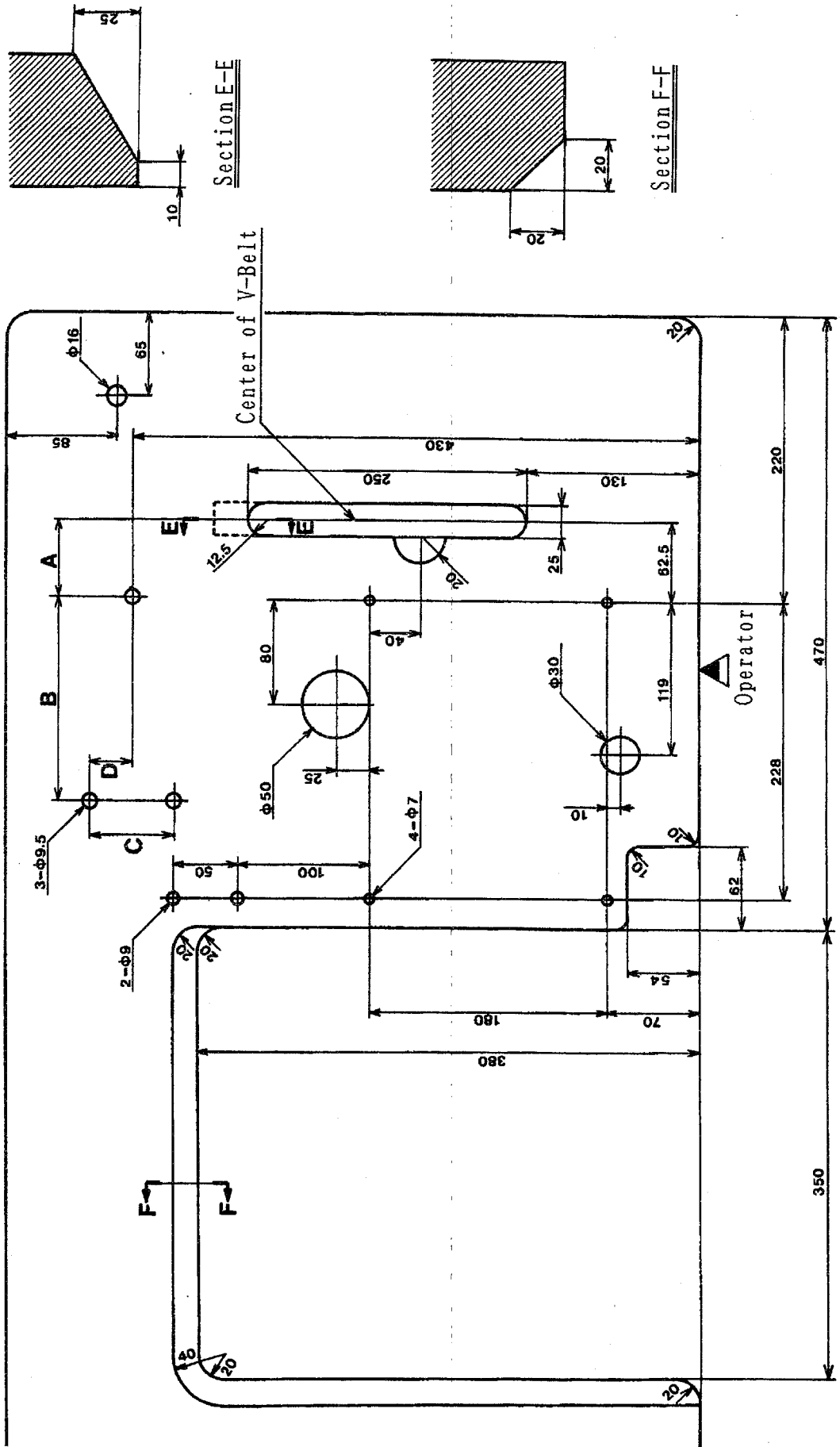

Maker	A	B	C	D
Panasonic	57	159	66.5	33.25
Mitsubishi	60	150	65	32.5

### 3-2 Table top installation

Install machine referring to the illustration. Fit Bolts and Nuts to the table, put Rubber Cushions on Bolts and mount machine on them securely.

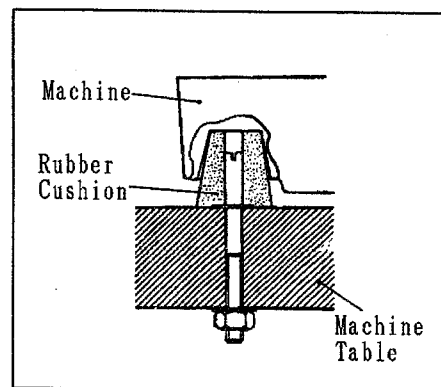

### 3-3 Fixing Belt Cover

Fix Belt cover as illustrated.

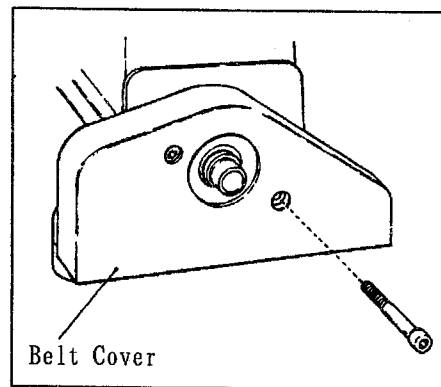

## 4. Sewing speed and rotating direction

Maximum sewing speed is 4,000 s.p.m.

It is recommended for the durability to operate at the speed 15%~20% lower than maximum speed for the initial 200 hours (about 1 month), then operate at the ordinary speed.

The rotating direction of Pulley(A) is clockwise like Handwheel(B).

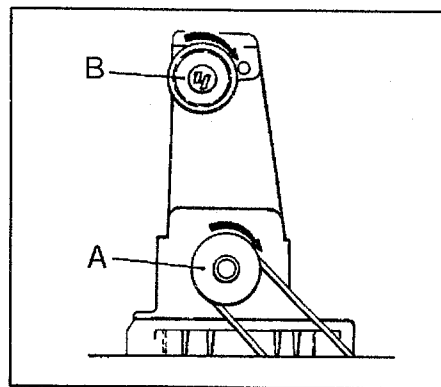



## 5. Motor and Belt

Use a motor designated by us as it is to be equipped with Thread Trimmer. (See tables below.)

Note: When installing a motor shown below by procuring it separately, the switch inside (dip switch) must be changed.

Use a belt of M-type.

Position the motor so that the centerline of Motor Pulley align with that of Machine Pulley.

Dia. of Motor Pulley (mm)	s.p.m. of machine	
	50 Hz	60 Hz
75		4,000
90	4,000	

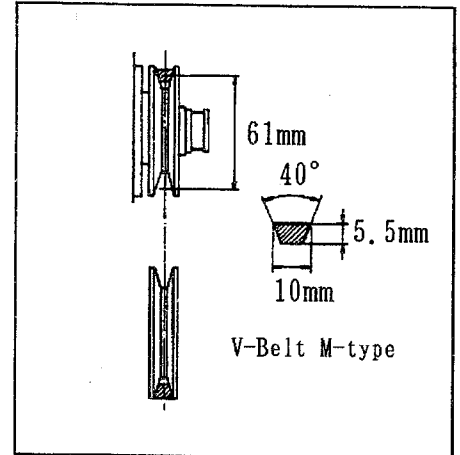

Note: In case of operating at the speed under 4,000 SPM, Adjust "Max. Speed Knob" in Control Box.

(Servo Motor)

Maker	designation(Yamato)	Voltage	Maker	designation	Voltage
Panasonic	MPXA11YN1	100	Panasonic	MAXA21YN1	220, 240
	MPXA21YN1	200			
Mitsubishi	XL-10-XC-36K-A	100	Mitsubishi	XL-20-XC-36K-B	220, 240
	XL-20-XC-36K-B	200		CB-Z552E-LF-36KA-360 (electronics motor)	over 240

## 6. Lubrication oil

### 6-1 Lubrication oil

Use YAMATO SF OIL for lubrication.

### 6-2 Feeding of oil

As lubrication oil has been drained completely before shipment, feed oil before operation without fail. Feeding of oil is made by removing Rubber Seal Plug(A) indicated "OIL IN" and feed oil up to the upper line of Oil Sight Gauge(C).

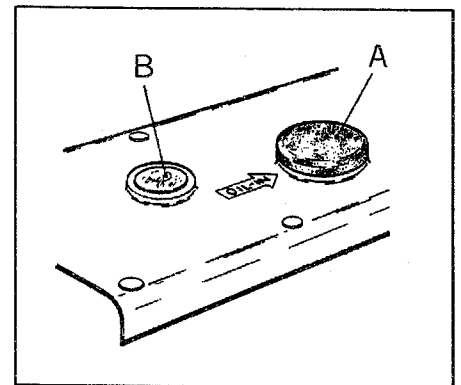

### 6-3 Oil Sight Gauge and Nozzle

Check Oil Sight Gauge(C) before operation every day. If the oil is under 2 lines, feed oil. Make sure that the oil flows out of Nozzle(B) at the start of operation.

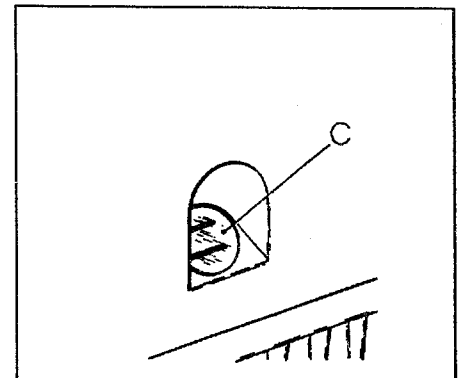

### 6-4 Oil change

For the long service life of machine, lubrication oil of new machine should be changed after 250 hour of operation.

Oil change should be made following the next procedure:

- ① Remove V-belt from Motor Pulley and remove machine from table.
- ② Remove Drain Screw(D), and drain oil.  
At the time, take care not to smear V-Belt.
- ③ Tighten Drain Screw(D) after drain.
- ④ Refer to item "5-2 Feeding of oil" when supplying new oil.

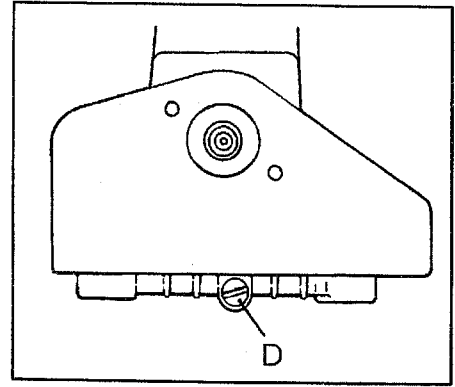

### 6-5 Check and change of Oil Filter

When Oil filter(E) is clogged with dust, proper lubrication is not possible. Usually check it every 6 months .

If oil does not or very little oil flows out of Nozzle despite enough oil is in Oil Reservoir, check carefully.

Check of Oil Filter is made by removing Oil Filter Cap(F).

If the oil filter is clogged, renew it.

Note : When removing Filter Cap, pay attention to the leak of oil collected on the filter.

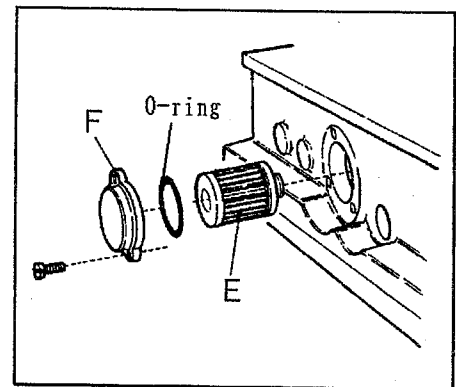

### 6-6 Cleaning of machine

Clean the machine to remove dust and chips collected inside every day at the finish of operation.

Cleaning is made by opening Side Cover and Front Cover and remove dust and chips using air gun or the like.

And every one or two weeks, after removing Rubber Seal Pulg(G), remove dust collected on Oil Filter Screen using tweezers.

If this Filter Screen is clogged, oil around Feed Bar does not return to Oil Reservoir and might be splashed.

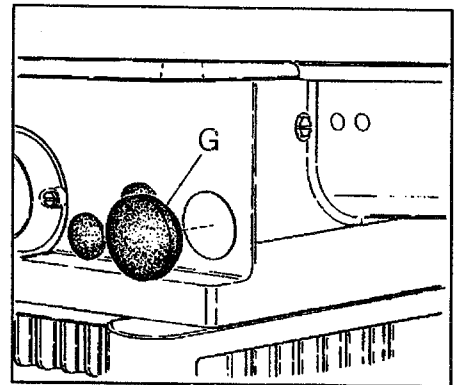

### 6-7 Oiling Take-up Shaft Bracket

Supply a few drops of oil to the two oil holes(H') on Take-up Shaft Bracket(H) everyday before using the machine. The holes are painted red.

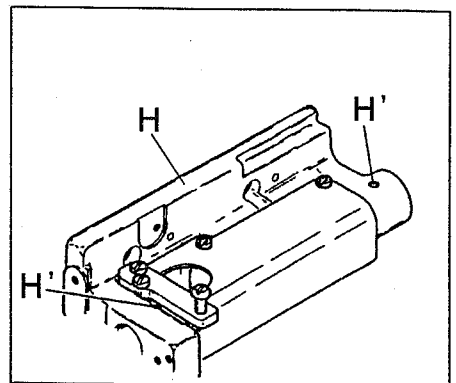

## 7. Air piping and Suction Pipe

### 7-1 Air piping diagram

※ Set air pressure to 0.45MPa(4.5kgf/cm<sup>2</sup>) by Regulator. Pay attention to the air pressure because if it drops below 0.4MPa(4kgf/cm<sup>2</sup>), it may cause malfunction of "UT" Device.

\* In case of VC2840P/UT-A50

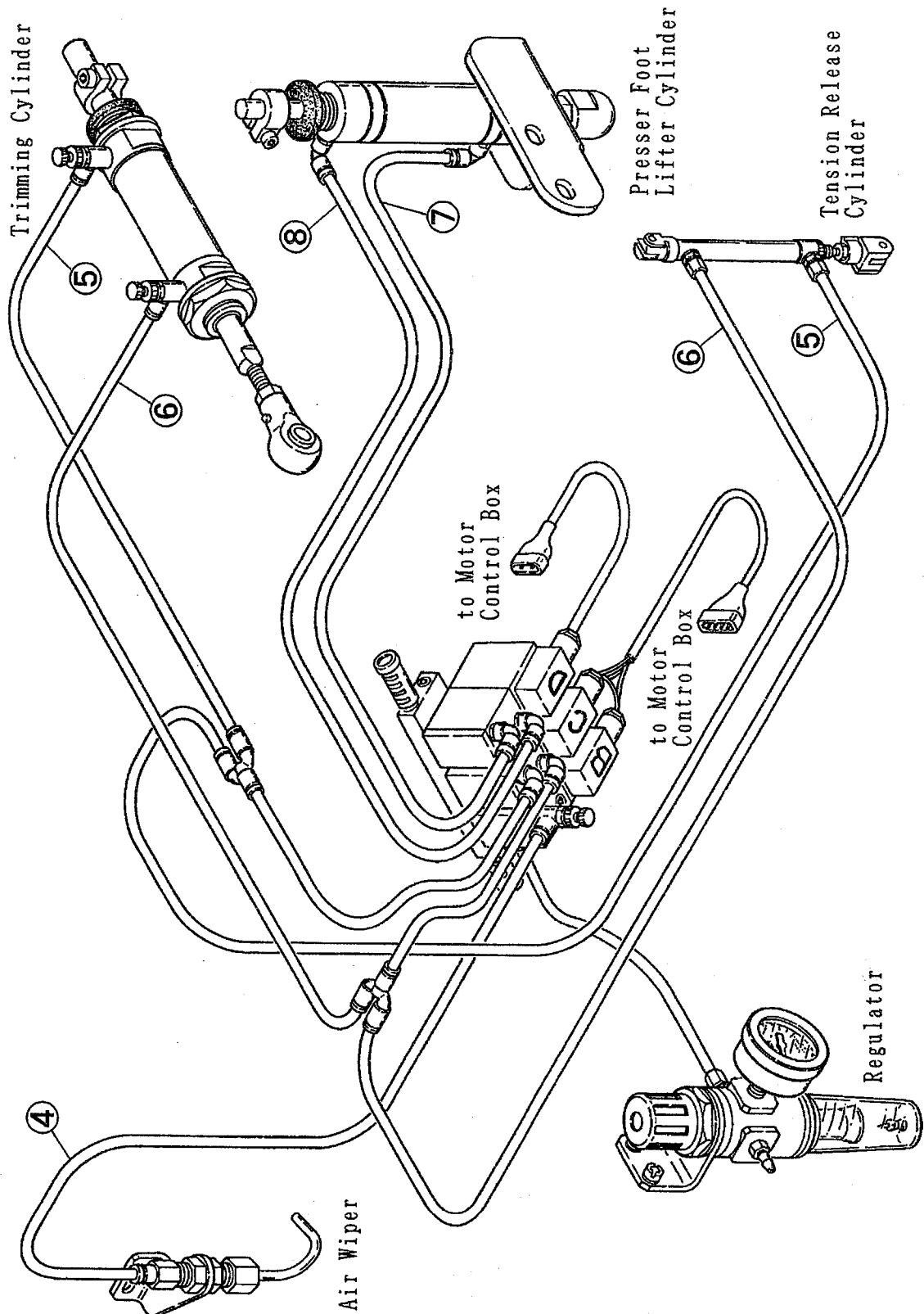

\* In case of VC2845P/UT-A50/AS4

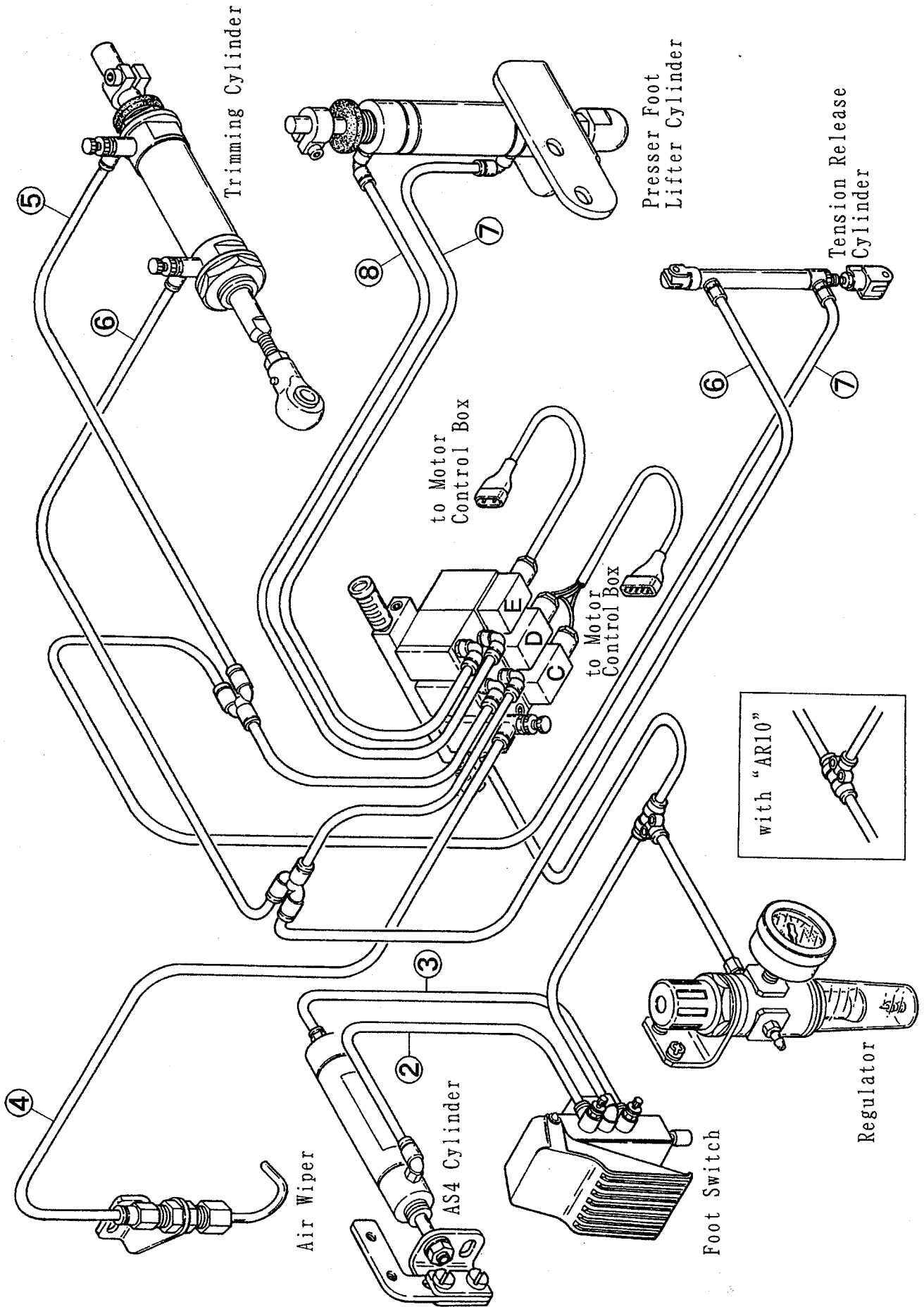

## 7-2 Adjustment of Speed Controller

### \* Trimming Cylinder

Adjust Speed Controller(B) when operating trimming, and adjust Speed Controller(A) to make the shock minimum at the time of returning.

The standard adjustment is : for Speed Controller(A) return Adjusting Knob 1 1/3 turn from the most screwed-in position, and for Speed Controller(B), return 1 1/2 turn from the most screwed-in position.

### \* AS4 Cylinder (VC2845P only)

When operating Folder, adjust Speed Controllers(C) and (D) so that the shock becomes minimum.

### \* Air Wiper

Adjust Speed Controller(F) to make the air amount minimum.

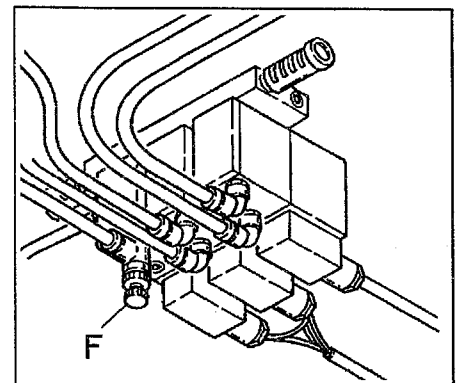
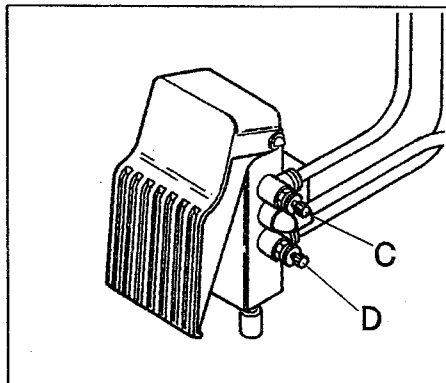
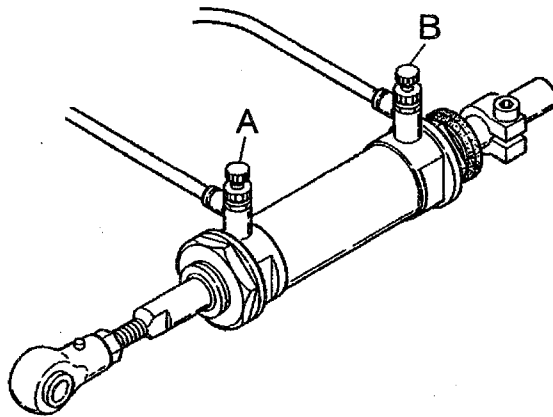

## 8. Proper operation

### 8-1 Needles to be used and their setting

Needles to be used are Schmetz or Organ TV×5.  
There are many kind of needle size. Select the most suited needles to the thickness or material.

Japanese size	12	14	16
Metric size	80	90	100

When changing needle, with scarf facing rightly backward, set the needles correctly as illustrated.

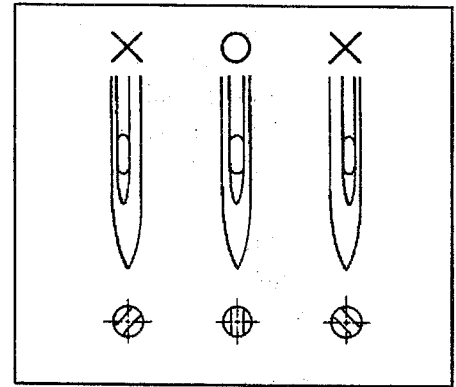

### 8-2 Threading

Make threading correctly referring to the illustration.  
Wrong threading will cause skip stitch, thread breaking and uneven thread tension.

A, B, C, D, E ... needle thread,                      F, G, H, I ... looper thread

Illustration shows in case of 5-needles and 4-loopers.

Note : In case of VC2840P-254-X02B, needle thread(A) is not necessary.

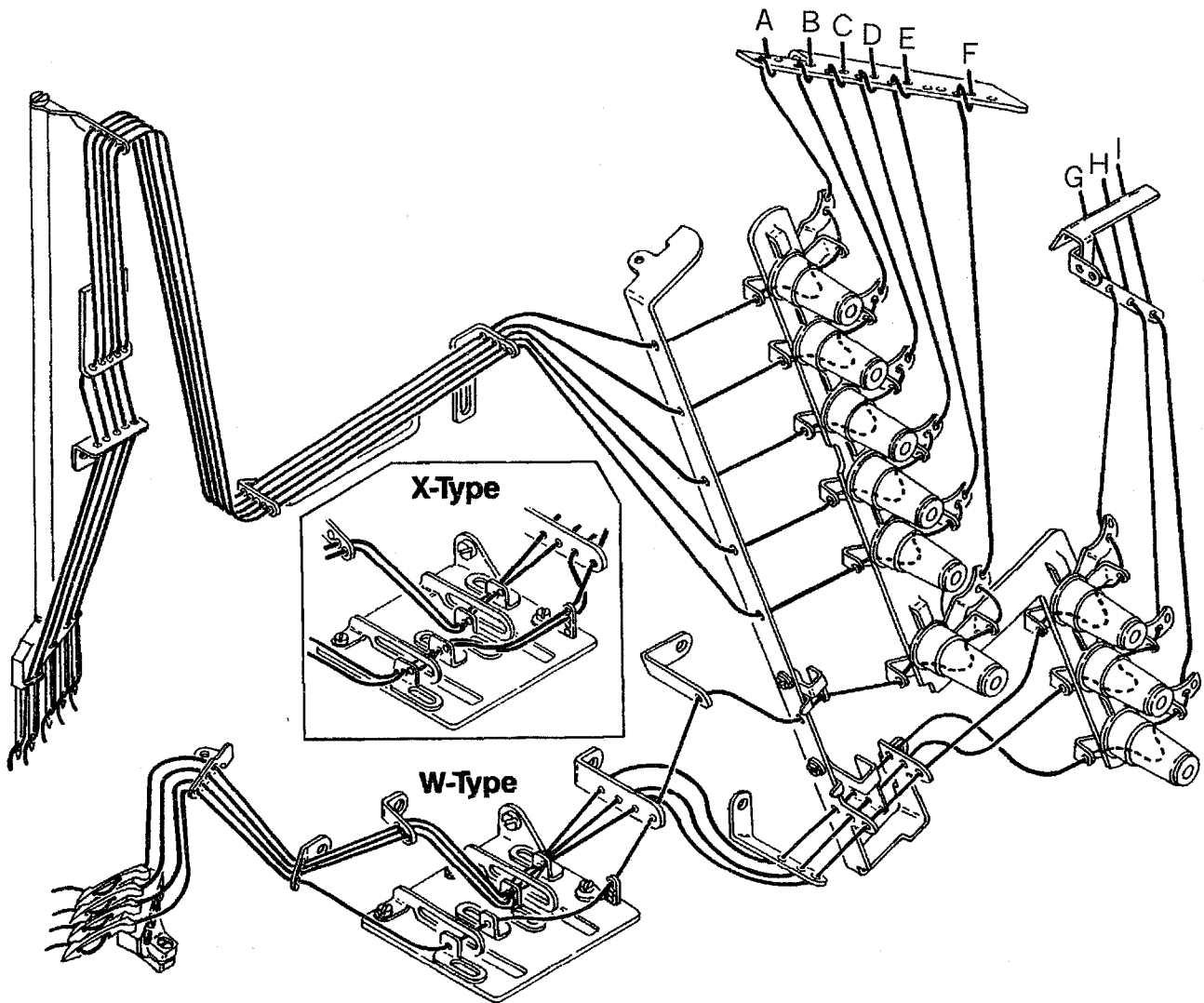

### 8-3 Pressure of Presser Foot

After loosening Lock Nut (A), when turning Adjusting Screw (B) to the right, the pressure of Presser Foot becomes strong and turning it to the left, it weakens.

Adjust the pressure of Presser Foot most weak as long as it works properly.

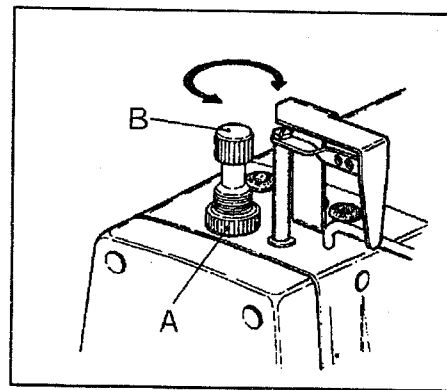

### 8-4 Adjustment of Presser Foot

After loosening Screw (D), adjust the longitudinal and lateral needle drop position of Presser Foot (C) so that needles drop to the centers of needle drop position. Then tighten Screw (D).

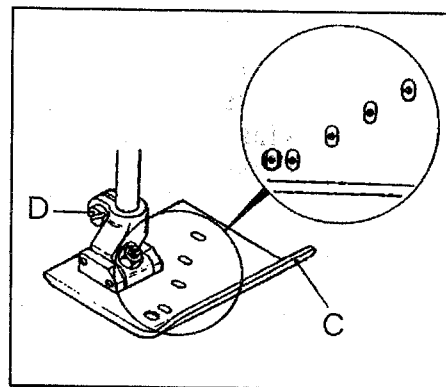

### 8-5 Adjustment of stitch length

Stitch length can be adjusted continuously from 1.4mm to 5.0mm. The stitch length is indicated by stitch number per inch (25.4mm) and per 30mm on the table below.

stitch length (mm)	stitch number (per inch)	stitch number (per 30mm)
5.0	5	6
4.0	6.5	7.5
3.0	8	10
2.0	12	15
1.4	18	21

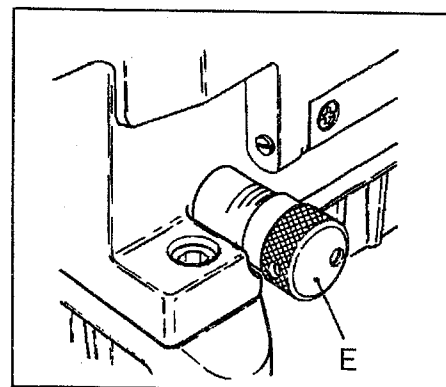

#### \* Change of stitch length

Stitch length (feed amount) can be changed freely by turning Adjusting Knob (E).

Graduation indicates the stitch length.

Note : When turning Adjusting Knob (E), loosen Nut (F).

Note 1 : Feeding mode of this machine is plain feeding and differential feeding is not possible.

Note 2 : When changing stitch length, turn Motor Switch "OFF" without fail.

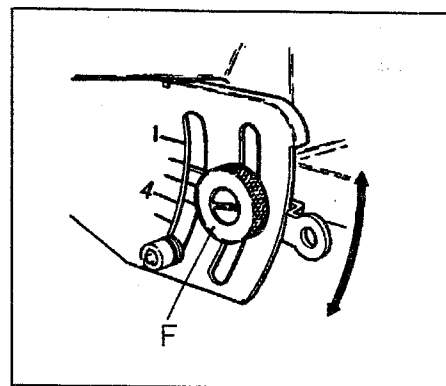

## 9. Adjustment of sewing machine

※ The adjustment from item 9-1 to 9-8 are the same for needle lineup of "X", "Y" and "W".

### 9-1 Needle thread tension

The tip of Needle Thread Take-up(A) is 57mm from the center of Screw(B) and the portion(a) of it is horizontal when Needle Bar is uppermost.

That is the standard condition.

To tighten needle thread, move Needle Thread Take-up(A) to the direction(Y) and to slacken, to the direction(X).

The adjustment is made by loosening Screw(B).

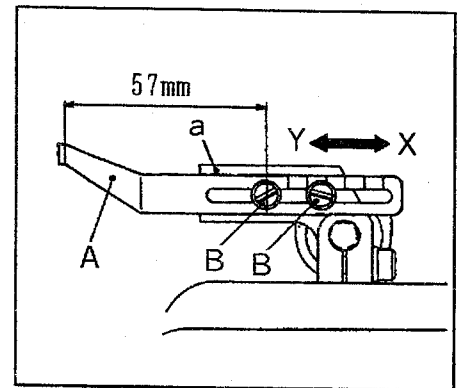

If this adjustment is not sufficient, loosen Screw (C) and move Eyelet(D) and check thread tension.

When moving it to the arrow(Y) direction, the thread tightens and to the arrow(X) direction it loosens.

The standard position of the tip of Eyelet is 18mm from the center of Screw(C).

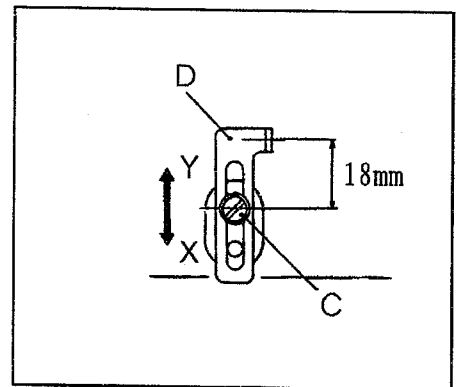

\*In case of loop formation is unstable as when using stretchable thread like synthetic fiber thread, use Needle Thread Guide. With Needle Bar lowermost position, the height of Eye center of Needle Bar Thread Eyelet(E) and the surface of Needle Thread Guide(F) are the same and (E) and (F) is parallel with each other. That is the standard condition.

Adjustment of height and lateral position of Needle Thread Guide(F) is made by loosening Screw(G).

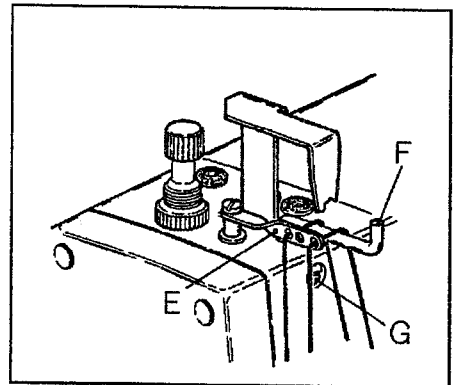

### 9-2 Looper thread tension

The illustration shows the part of Looper Thread Take-up. The standard adjustment is to set Eyes of Eyelets(B), (C), (D), and (E) to the Mark(X) of Supporting Plate(A).

To increase feeding of thread, move each Eyelets forward and to decrease, move them backward after loosening screws of each Eyelets.

Note : Too much feeding of thread cause skip stitch.

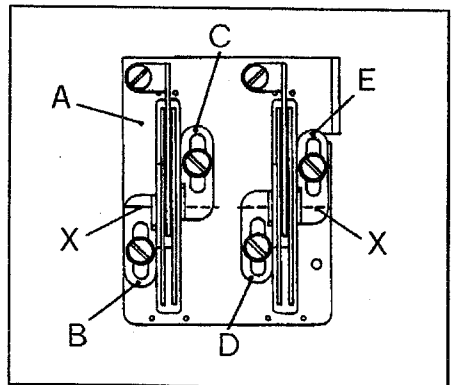



### 9-3 Position of Loper Thread Take-up

The illustration is Loper Thread Take-up viewed from Needle Bar side. Adjust so that the thread comes off from the highest point of Loper Thread Take-up(F) when the left Needle reaches to the mid point of Loper after descending from uppermost position. The adjustment is made by loosening Screw(G).

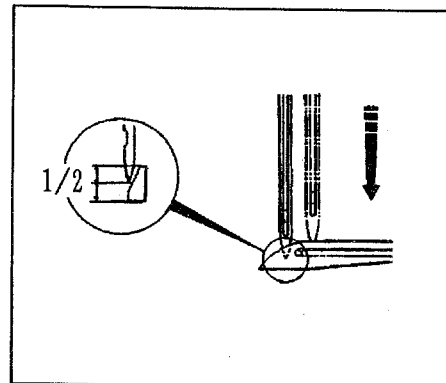
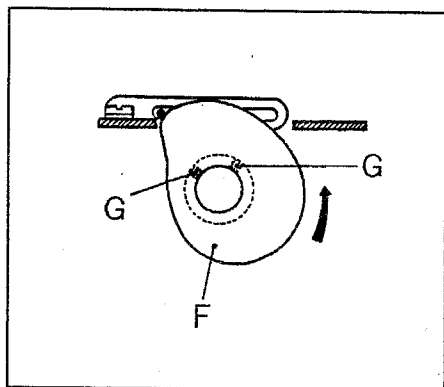

### 9-4 Removing Presser Foot and its lift amount

To remove Presser Foot, loosen Screw(A) and push down Lifter Lever(B).

The adjustment of Presser Foot lift amount is made by the Collar attached to Presser Foot Lifter Cylinder.

(Refer to the attached Instruction Manual for "UT-A".)

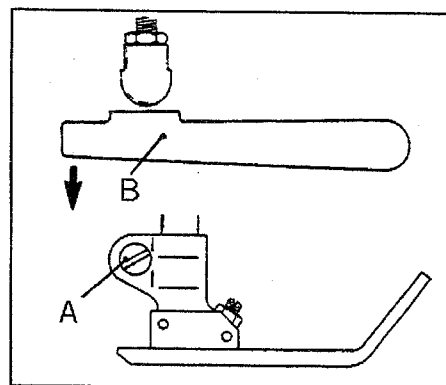

### 9-5 Relation between Needle and Stitch Plate

After adjustment of Needle Bar height, adjust the each clearances to the needle drops to be same. The adjustment is made by moving Needle Bar and Stitch Plate.

After adjustment, tighten Screw(C) of Stitch Plate securely.

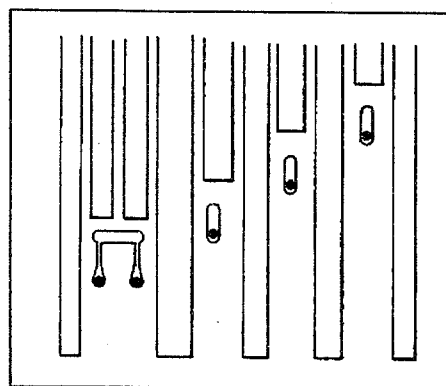

### 9-6 Removing Stitch Plate

When threading looper thread and adjusting Loper, Stitch Plate can be removed together with Stitch Plate Support, following the procedure below:

- ① Remove Presser Foot.
- ② Open Side Cover.
- ③ Push the tip of Stitch Plate Clamp(D) backward.
- ④ Raise Stitch Plate together with Stitch Plate Support a little.
- ⑤ Shift them backward and remove.

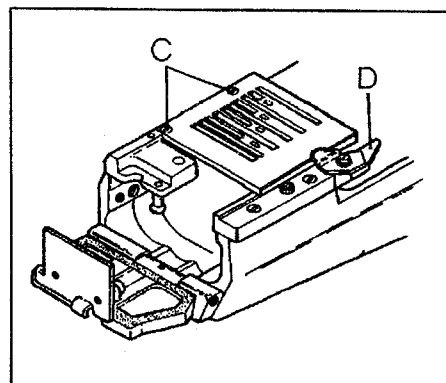

### 9-7 Setting angle of Loopers and their height

When inserting Looper all the way into Looper Holder(A) and tightening Screw(B) the height and fixing angles( $2^{\circ}$ ) are fixed accordingly.

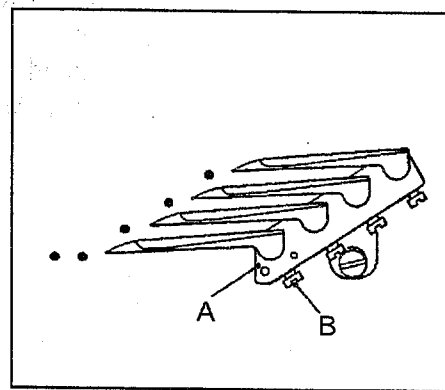

### 9-8 Height of Feed Dog

When Feed Dog rises uppermost, the surfaces of Feed Dog and Stitch Plate become parallel. At this time, make the distance between the surfaces of Feed Dog and Stitch Plate about 1.2mm.

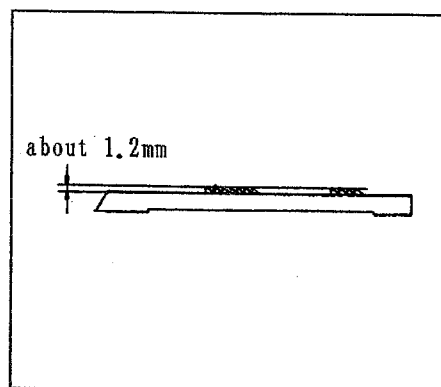

Note : For the items described below, the adjustment and standard are different according to the needle line-up style.

The adjustment should be made by the next procedure:

### 10. In case of needle line-up style "X"

#### 10-1 Timing between Needle and Loper

Based on Needle(b'), at the position where Loper(B) advances 9mm from the most retreated position, adjustment is made so that the needle is 0.8mm higher at returning stroke of Loper than going stroke.

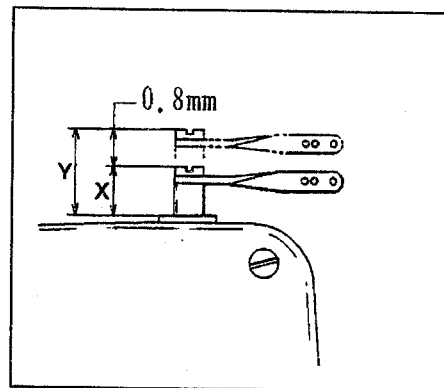
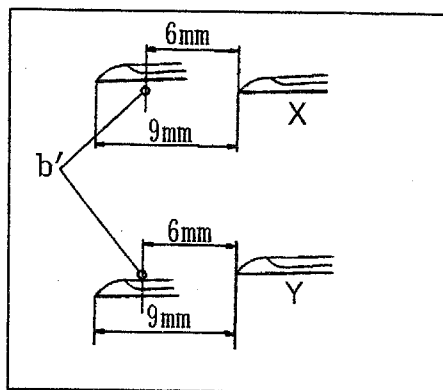

#### 10-2 Amount of Loper movement to the right

When Loper moves all the way to the right, the distance between the centers of each needle and the tips of corresponding Loopers is 4mm.

The adjustment is made by loosening Screw(F) of Loper Holder.

The adjustment of amount of Loper movement to the right can easily be made by using Loper Timing Gauge(95220) and utilizing Mark "B".

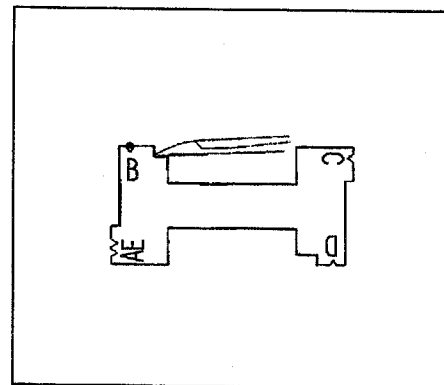
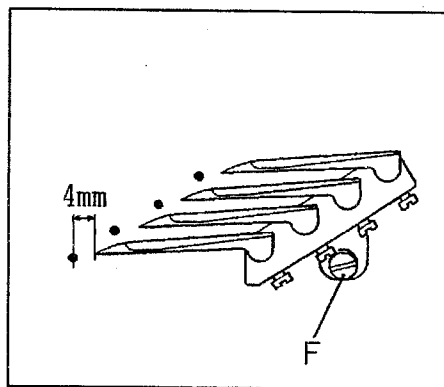

### 10-3 Height of Needle Bar

When the tip of Loper comes to the center of Needle, it must pass 0.5~1.0mm above the upper end of eye of needle. i.e. the height of needles are fixed based on Loper.

Of course, needles must be inserted all the way into Needle Clamps and fixed securely and also Loopers must be inserted all the way into looper Holder and be fixed securely.

The adjustment of needle height is made by putting a screw-driver into the Opening(G) of Head Cover and loosening Screw(H) of Needle Bar Bracket then moving Needle Bar up and down.

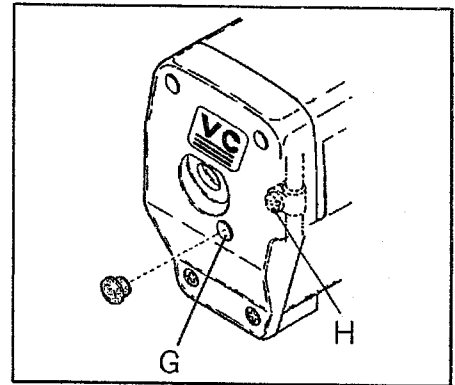
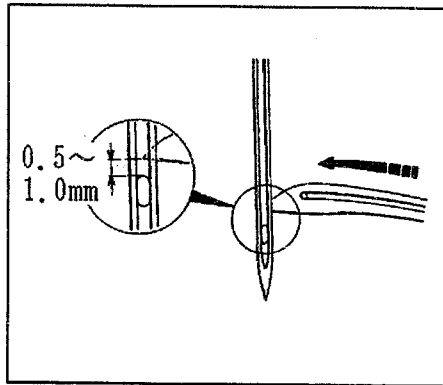

### 10-4 Relation between lengthwise positions of Needle and Loper

When the tip(b) of Loper meets Needle(b'), the tip of Loper must interfere Needle slightly.

The adjustment is made by loosening Screw(F) of Loper Holder.

Then adjust the clearance between the tip and Needle to 0~0.05mm by pushing Needle Guard(Rear).

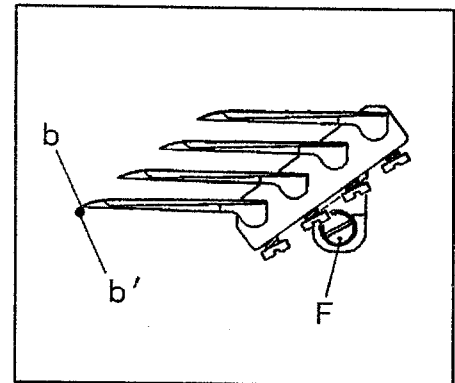

### 10-5 Needle and Needle Guard(Rear)

#### \* Height of Needle Guard(Rear)

With Needles at their lowest positions, align lines(i) of Needle Guard(Rear)(I) with the centers of Eye of Needles.

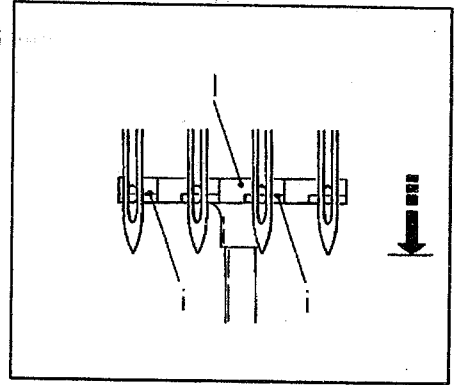

#### \* Lengthwise position of Needle Guard(Rear)

When the tip(b) of Loper meets the center of Needle (b'), the clearance between Needle and Loper must be 0~0.05mm. The adjustment is made by pushing Needle Guard(Rear)(I).

Also other Needles must have the clearance of 0~0.05mm.

The adjustment is made by loosening Screw(J) and (K).

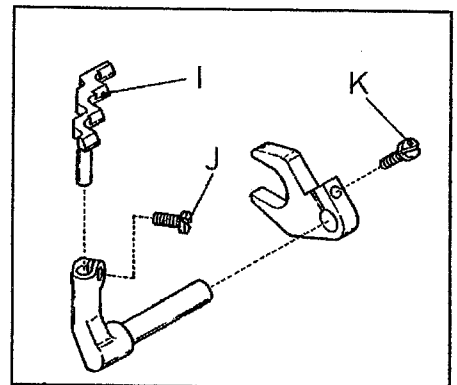
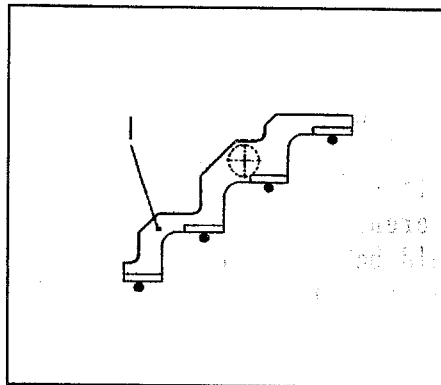

## 11. In case of needle line-up style "W" and "Y"

Note : The following adjustment is described for 2 needle interlockstitch machine (left 2 needles).

The basic adjustment is made regarding these 2 needles.

### 11-1 Timing between Needle and Loper

At the position where Loper(A) advances 9mm from the most retreated position, the adjustment is made so that the needle is 0.8mm higher in returning travel than going travel.

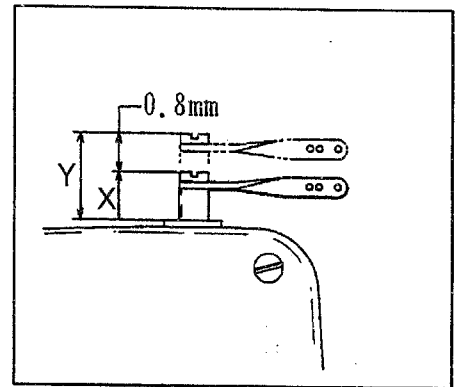
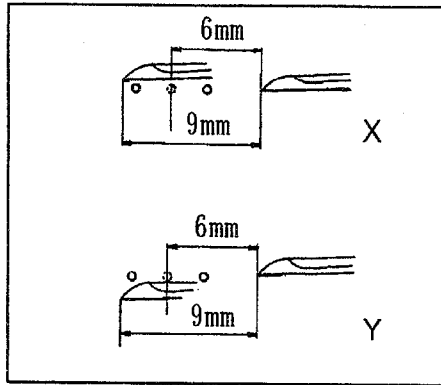

### 11-2 Amount of Loper movement to the right

※ Adjustment is made based on Loper(A).

With the needle at the lowermost position, when Loper moves all the way to the right, the distances(M) between the centers of each Needle and the tips of corresponding Loopers are different according as the needle distance. It should be adjusted referring to the table below. The adjustment is made by loosening Screw(F) of Loper Holder.

needle distance (mm)	(symbol)	Looper movement to the right (mm)
3.2	(A)	4.4
4.0	(B)	4.0
4.8	(C)	3.6
5.6	(D)	3.2
6.4	(E)	2.8

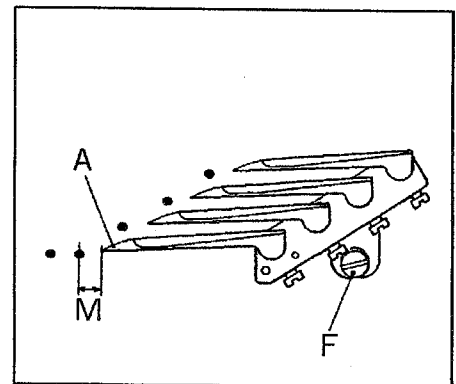

\* The adjustment of the amount of looper movement to the right can be made easily by using Loper Timing Gauge(95220). But the Timing Gauge is optional, and if you want, request it to the agent or directly to us.

### 11-3 How to use Loper Timing Gauge

The symbols (A, B, C, D and E) of each needle distance is inscribed on Loper Timing Gauge.

When Loper goes all the way to the right, keeping the condition that the right hand needle enters into the corresponding V-groove, apply the tip of Loper to the Gauge and tighten Screw(F) on Loper Holder.

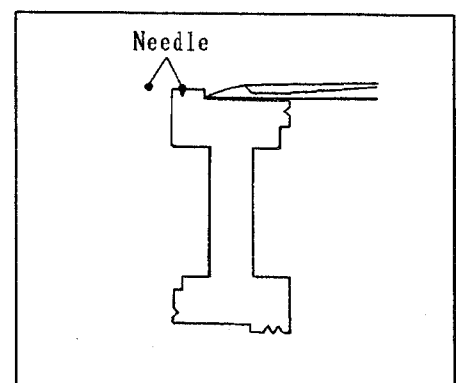

#### 11-4 Height of Needle Bar

When the tip of Loper comes to the center of left Needle, the tip must pass 0.5~1.0mm over the upper end of eye, i.e. the height of Needle is determined based on Loper.

Of course the Needle and Loper must be inserted all the way into the hole of Needle Clamp and Loper Holder respectively and be fixed securely.

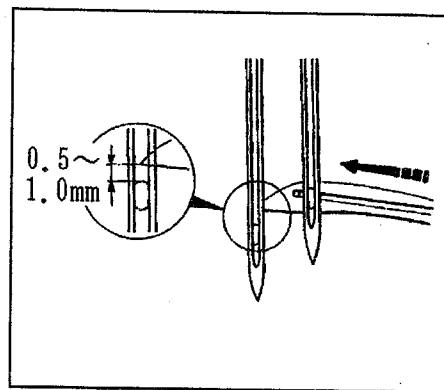

The adjustment of height of Needle is made by inserting a screwdriver through the Opening(G) of Head Cover, loosen Screw(H) of Needle Bar Bracket and moving Needle Bar up and down.

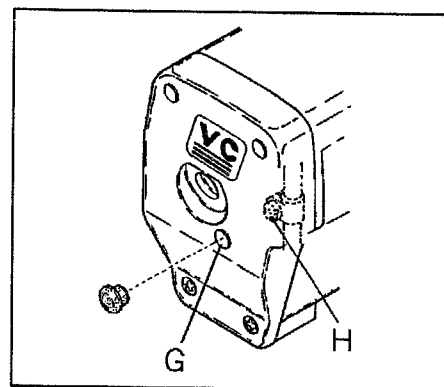

#### 11-5 Relation between lengthwise positions of Needle and Loper

When the tip(a) of Loper meets left Needle(E), the clearance between them must be 0.2~0.3mm. And when the tip(a) of Loper meets the right Needle(a'), they must interfere slightly.

The adjustment is made by loosening Screw(F) of Loper Holder.

Then adjust the clearance between the tip of Loper and Needle(a') to 0~0.5mm by pushing Needle Guard(Rear) against Needle(a').

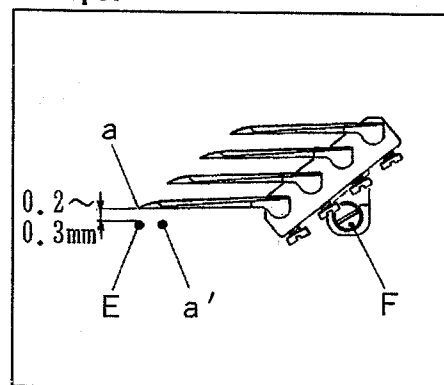

### 11-6 Needle and Needle Guard(Rear)

**\* Height of Needle Guard(Rear)**

With Needle is lowermost position, align lines(i) of Needle Guard(Rear)(I) with the centers of Eye of Needles.

**\* Lengthwise position of Needle Guard(Rear)**

When the tip of Loper comes to the center of Needle, the clearance between Needle and Loper must be 0~0.05mm. The adjustment is made by pushing Needle Guard(Rear).

Also, for other Double Chaining needles, set the distance at 0~0.05mm.

These adjustments are made by loosening Screw(J) and (K).

The clearance between left Needle and Needle Guard(Rear) is about 0.2mm.

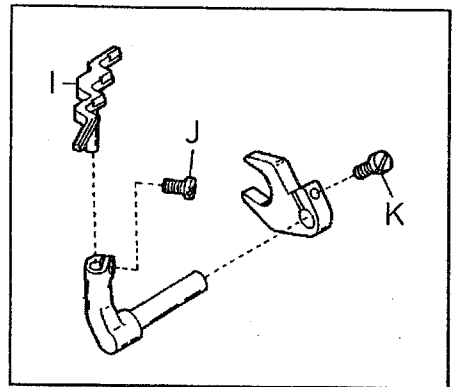
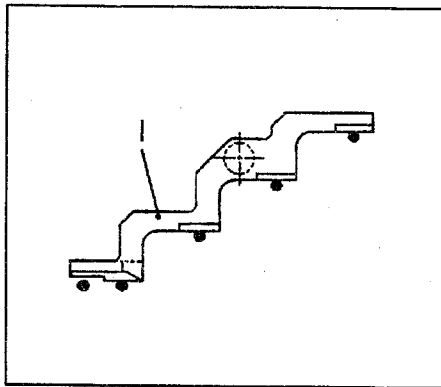
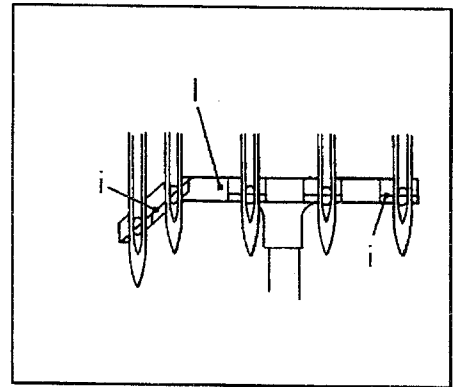

### 11-7 Needle and Needle Guard(Front)

When the tip of Loper comes to the center of left Needle, the clearance between left Needle and Needle Guard(Front)(L) must be 0~0.3mm.

The adjustment is made by loosening Screw(N).

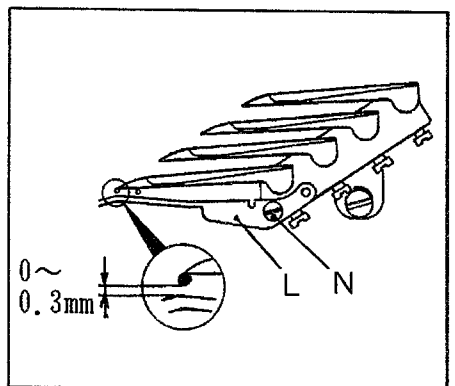



## 12. Adjustment of Tension Rollers and Folder

### 12-1 Setting of Tension Rollers

- \* Install Tension Roller Holder (A) to the position shown in the illustration.

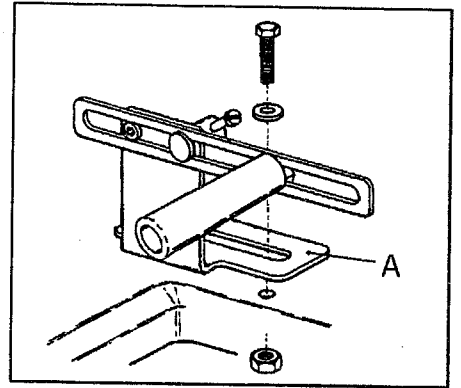

- \* Install Bracket (B) to the suitable position under the table.

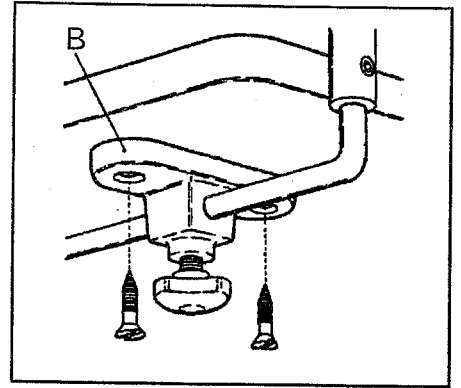

- \* Install Lower Roller Support (C) to the position of the cylinder under the table.

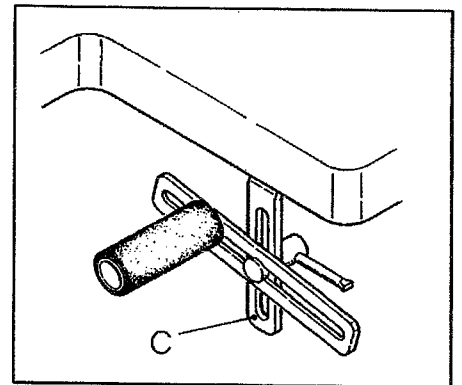

## 12-2 Procedure of sewing (In case of VC2845P-254-X02D/UT-A50/AS4)

- ① Move Fabric Guide to the left by pressing Knee Switch.
- ② Raise Presser Foot and set elastic tape on Elastic Tape Guide(D) and (d).
- ③ Move Fabric Guide(G) to the right by pressing Knee Switch.
- ④ Apply fabric to Folder(H) and Fabric Guide(G), turn the fabric to the sewing direction.

As the fabric is bended by Folder and Fabric Guide, turn the fabric until the end of fabric reaches to the left end-surface of Fabric Guide(G) as illustrated. Then raise Presser Foot.

- ⑤ Set fabric on Tension Roller. Then with enough margin for folding width to the right, begin sewing.

With hand on it lightly, handle the fabric not to shift right or left.

To try to bend fabric forcibly by hand will cause the change of tension on fabric leading to troubles.

- ⑥ When the portion of sewing start comes before Fabric Guide(G), release the fabric from Fabric Guide by pressing Knee Switch (AS4 Device) and make sewing paying attention not to disarrange the edge of fabric and to conform the both seams of sewing start and sewing finish.

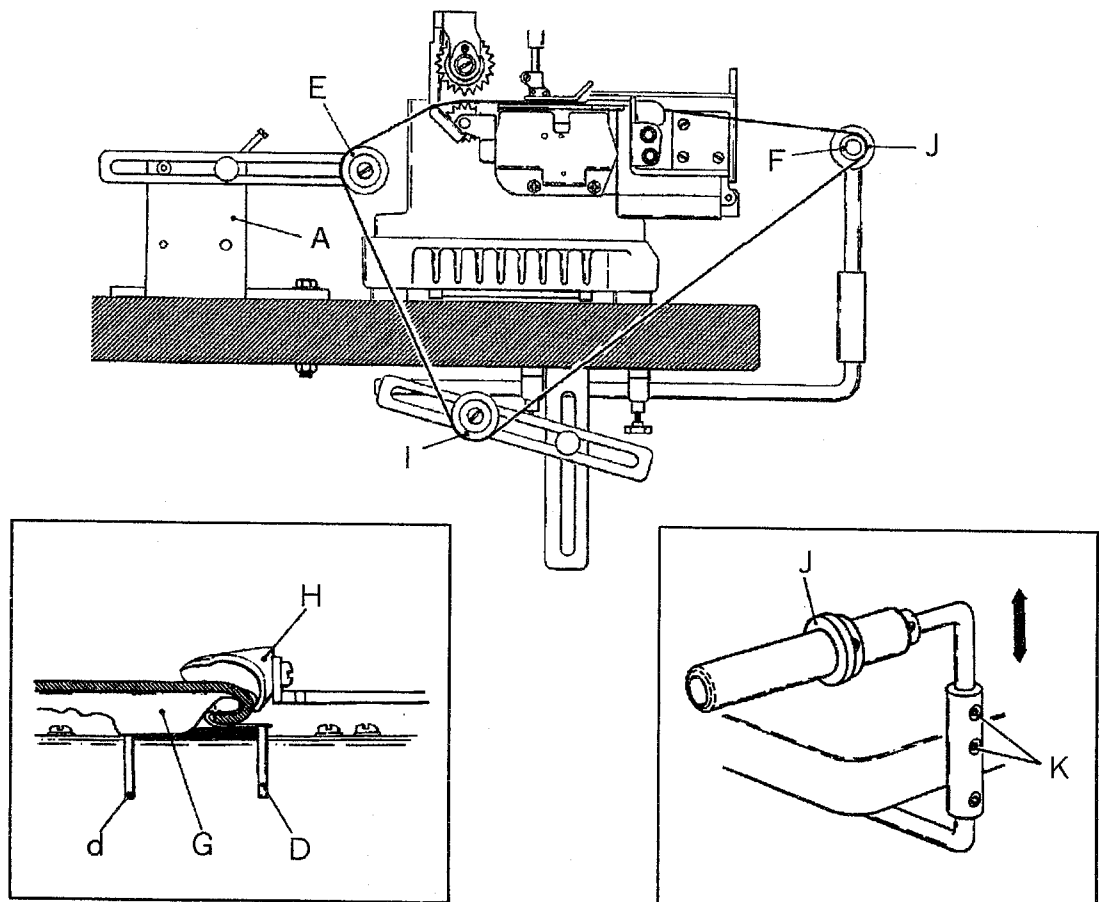

## 12-3 Adjustment of Tension Rollers

- \* Adapting to the size of unfolded garment body, install Tension Roller(Upper) (E) and Front Roller(F) to the suitable position.

Tension Roller(Upper) (E) can be adjusted forward and backward easily by loosening Lever.

Tension Roller(Upper) can be installed under Holder(A).

In case of large garment body, use Tension Roller(Lower) (I).

- \* Adjust lateral position of Elastic Tape Guide(Front) (J) of Front Roller to the right end of elastic tape.

Adjustment of vertical position and the direction of Front Roller is made by loosening Screw(K).

## 12-4 Adjustment of Folder

### \* Lateral position of Fabric Guide

Adjust the position of Fabric Guide(G) by loosening Screw(L) and moving the Guide left and right according to the fabric.

### \* Lateral position of elastic tape

Adjust the position of Elastic Tape Guide(Left) and (Right) by loosening Screw(M) and (N) and moving the Guide left and right according to the width of elastic tape and fabric.

### \* Position of the right end of fabric

Cut off the right end of Presser Foot(O) so that the right end of fabric conform to the proper condition for the right Needle.

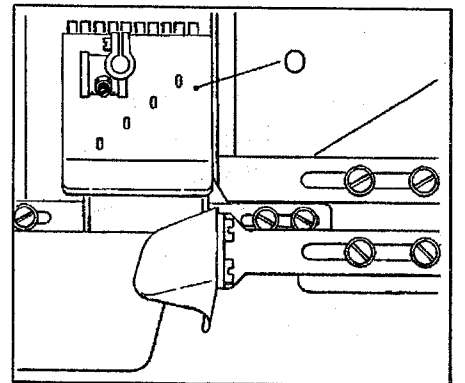
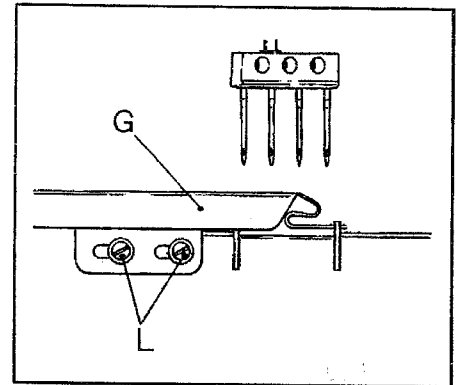
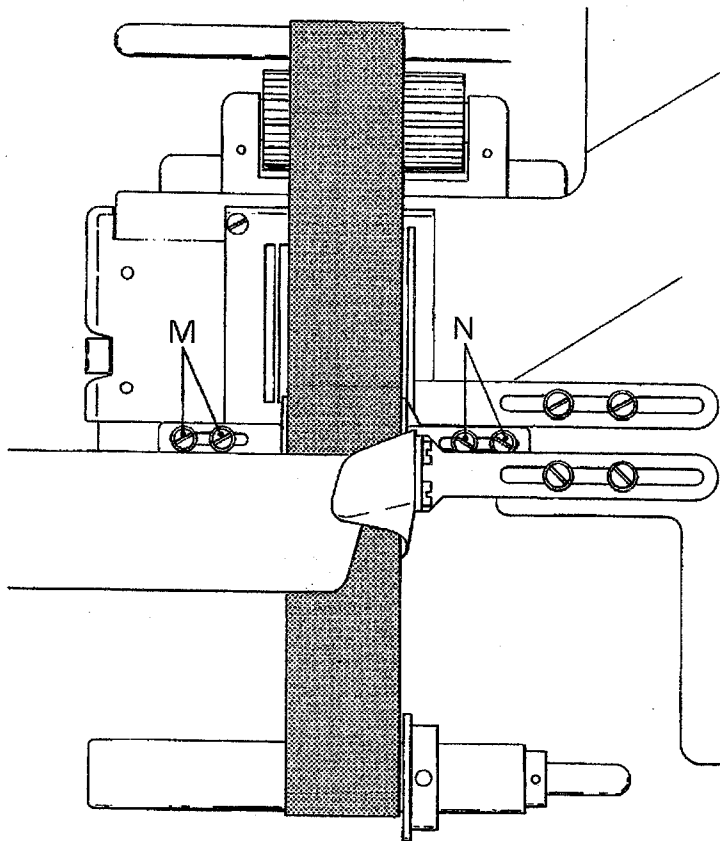

### 13. Adjustment of Puller Mechanism

#### 13-1 Position of Upper Feed Roller

The teeth of Upper Feed Roller must be parallel to that of Lower Feed Roller. And when Upper Feed Roller is lowered, the clearance between Upper and Lower Feed Roller must be 0.5mm. That the standard.

- \* Adjust the teeth of Upper and Lower Feed Roller to be parallel with each other. The adjustment is made by loosening Screw(A) of Upper Feed Roller Holder, Screw(B) of Yoke Guide and Screw(C) of Yoke Pin.

After positioning using Screws(A) and (B), make sure that it can be moved lightly up and down, then tighten Screw(C).

- \* Provide a clearance of about 0.5mm between Upper and Lower Feed Roller. When Upper Feed Roller is lowered, the adjustment is made by loosening Nut(D) and using Adjusting Screw(E). Adjust the clearance according to the thickness of fabric.

- \* Provide a clearance of 0.5mm between under-surface of slot in Lifter Connecting Plate(F) and Screw(G) when Presser Foot rests on the surface of Stitch Plate. The adjustment is made by loosening Screw(H) of Upper Feed Roller Lifter(Right).

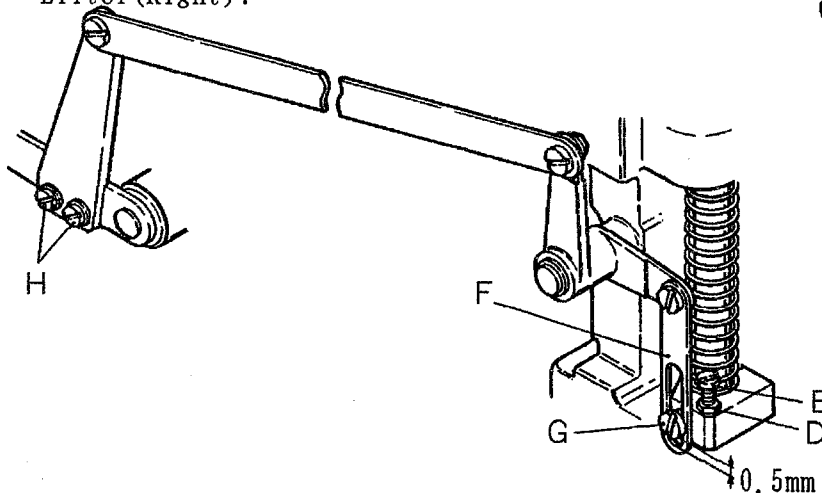
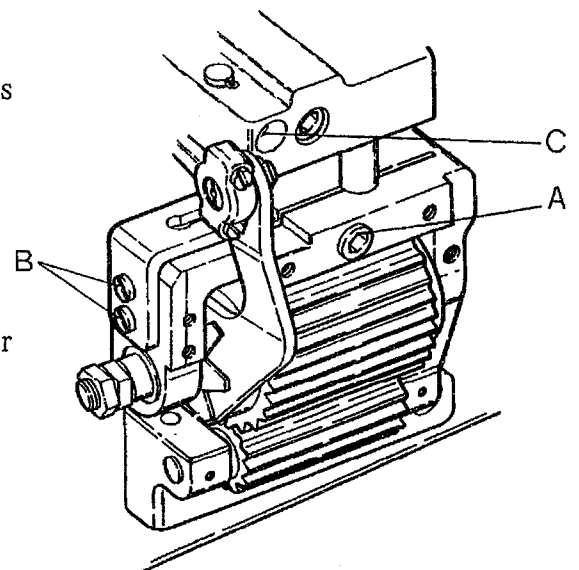
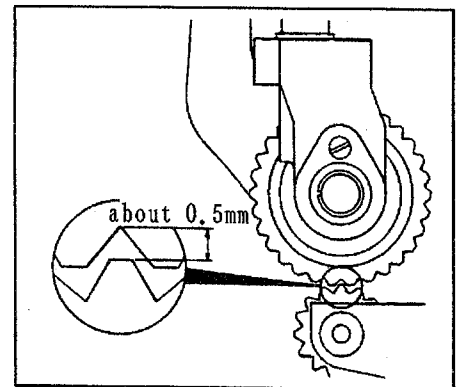

#### 13-2 Pressure of Upper Feed Roller

Set the pressure to the minimum necessary for feed, holding fabric between Upper and Lower Feed Roller. To increase the pressure, turn Adjusting Screw(I) clockwise and to decrease the pressure, turn it counterclockwise.

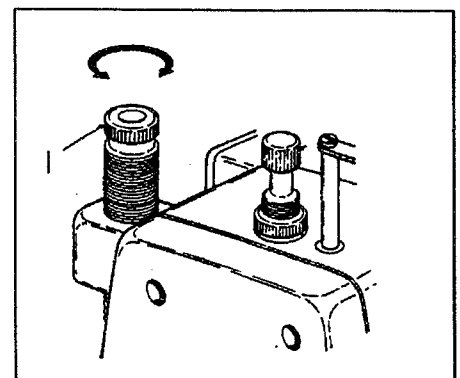

### 13-3 Adjustment of feed amount of Puller

The adjustment of feed amount should be made following the next procedure:

- ① Remove Seal Plug(A) from Top Cover.
- ② Turn Handwheel until Screw(B) of Main Feed Eccentric appears in the window, then loosen Screw(B).
- ③ Turn Handwheel until Adjusting Screw(C) appears in the window.
- ④ To increase the feed amount of Puller, turn Adjusting Screw(C) counterclockwise and to decrease, turn it clockwise.
- ⑤ Tighten Screw(B) of Main Feed Eccentric.  
Use attached hexagonal key wrench screwdriver. (tightening torque : 25 kgf·cm)  
For micro-adjustment of feed amount, loosen Nut(F) of Upper Feed Roller Lever Rod(E) fixed on Upper Feed Roller Lever(D) and move Rod (E) upward to decrease the feed amount or move it downward to decrease.

Note : Feed oil to 2 Oil Hole of Upper Feed Roller Lever Rod(E) before operation.

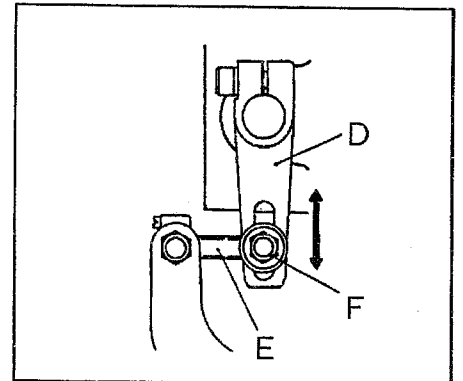
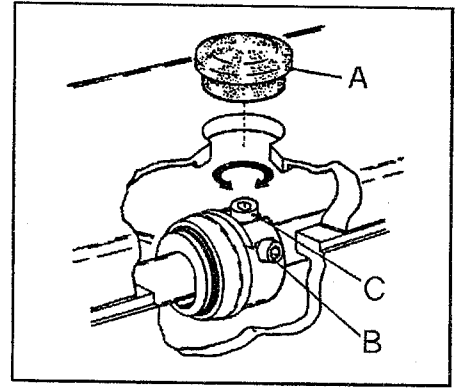

### 13-4 Adjustment of lifting amount of Upper Feed Roller

Upper Feed Roller(G) has been adjusted to rise 8mm above the circumference of Lower Feed Roller(I) when Upper Feed Roller Lifting lever(H) is pulled forward. Readjustment of lifting amount of Upper Feed Roller should be made following the next procedure:

- ① Bring down Upper Feed Roller Lifting Lever(H).
- ② Loosen Screw(J) of Roller Press Bar Bracket.
- ③ Engage Upper Feed Roller(G) and Lower Feed Roller(I) providing a little clearance between them.  
(Change the clearance according to the thickness of fabric.)
- ④ Tentatively set Lifting Lever Sleeve(K) fixed on Roller Press Bar Bracket to the portion(h) of Upper Feed Roller Lifting Lever with a little clearance with Screw(J).
- ⑤ Turn Stop Screw(L) of Upper Feed Roller, keep touching to the Arm tighten Lock Nut(M).
- ⑥ Make sure that Upper Feed Roller(G) is 8mm above the circumference of Lower Feed Roller(I), when Upper Feed Roller(G) is raised by pulling Upper Feed Roller Lifting Lever. Then tighten Screw(J).

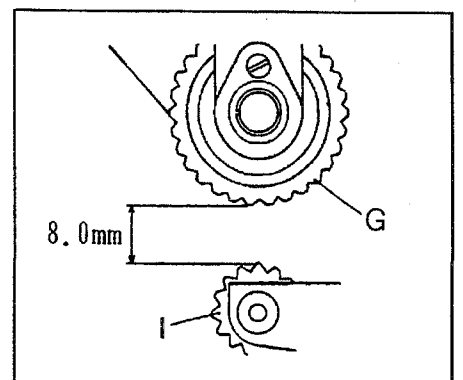
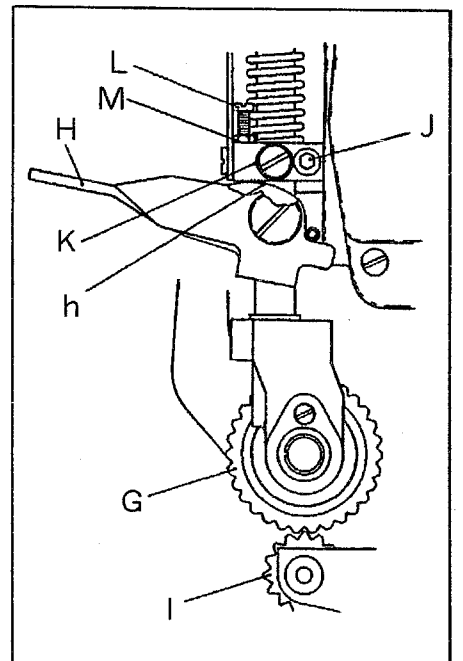

## "UT-A50/AS4" DEVICE

### 14. Operation

Note 1: When cutting off the air supply of this device, Upper Knife Carrier may be shifted to the left by Upper Knife Carrier Spring. Never run machine in this condition.

Before starting machine, make sure Thread Trimming Device is in the averting position to the right without fail.

Note 2: Never operate this device without fabric under Presser Foot.

- ① When treading Pedal (Fig.A), the machine starts and when releasing Pedal (Fig.B), the machine stops with Needle at the lowermost position.
- ② When treading back Pedal (Fig.C), the Needle rises and stops at uppermost position, Trimming Device operates to cut needle thread and looper thread under Stitch Plate and both threads are held by Clamp Spring. Then Presser Foot rises.
- ③ Remove fabric.
- ④ Presser Foot is lowered by returning Pedal to the position(B).
- ⑤ During the period from the cutting threads to the return of Pedal to the position(A) for the next sewing, up and down of Presser Foot can be done freely by treading Pedal to the position(B) or (C).

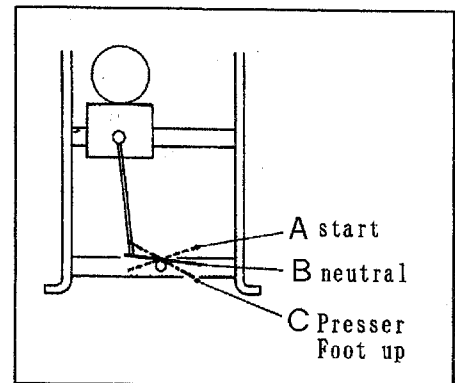

### 15. Connections of Electromagnetic Valve and Safety Switch

\* Electromagnetic Valve

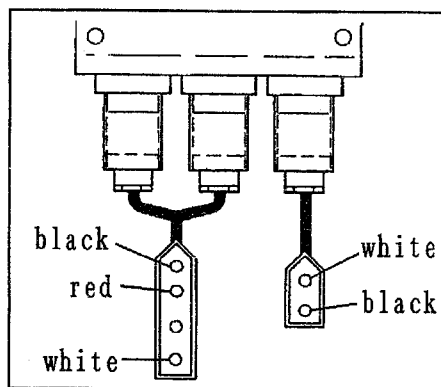

Note: Never short-circuit between black and red wires or between black and white wires because the short-circuit cause damage of inner circuit.

**\* Safety Switch**

A safety Switch is equipped not to turn machine unless Thread Trimming Device returns to the home position after operation.

Adjust this switch to be in the condition of being pressed ("ON") when Thread Trimming Device returns to the home position completely.

The adjustment is made by loosening Screw(A) and (B).

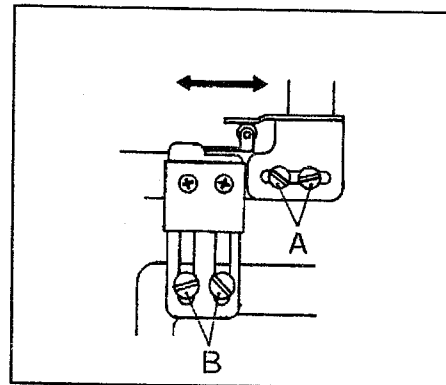
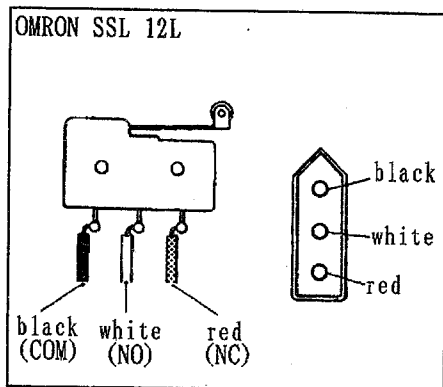

**1 6. Installation of Synchronizer**

- ① Install Synchronizer(A) to Machine Pulley and tighten Screws(B) tentatively.
- ② Fit Synchronizer Positioning Pin(C) in the guide groove of Synchronizer and tighten Screw(D).
- ③ Turn Motor Switch "ON".  
Note : Draw out the plug for Thread Trimming Cylinder.
- ④ Make two or three stitches by treading Pedal, then treadle back Pedal.  
At this time, Needle stops at a certain position.
- ⑤ Loosen Screw(B) of Synchronizer, turn Pulley and align Mark of Handwheel(E) to the mark on Arm , taking care not to shift the position of Screw(B).  
At this time, Needle Bar is in uppermost.  
For this device, the best Needle Bar position range is between the uppermost position and 0.5mm under it.
- ⑥ Treadle Pedal again, and make sure the stop position of Needle Bar is as described in Item ⑤.

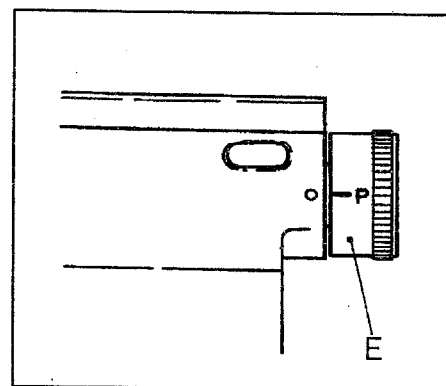
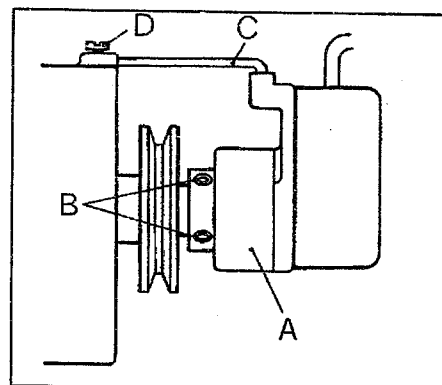

## 17. Adjustment of Trimming Cylinder

### 17-1 Installation of Plunger Connecting Rod

Install Plunger Connecting Rod(A) and Plunger(B) to Cylinder Return Shaft and to Shaft of Trimming Cylinder with Nut(C) and (D). At this time, Trimming Cylinder must move left and right smoothly.

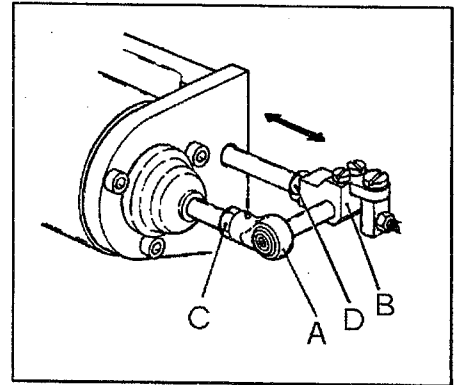

### 17-2 Stroke of Air Cylinder

The stroke of Air Cylinder is 25mm.

Adjustment is made by loosening Screw(J) of Collar(I).

### 17-3 Adjustment of Cylinder Returning Spring

The standard position of Collar(G) is 18~20mm from the end of Trimming Cylinder Support(H) when the plunger of Cylinder is all the way to the left (when Cylinder does not operate).

Note : Feed oil to Oil Hole (red marked) of Trimming Cylinder Support(H) once a week.

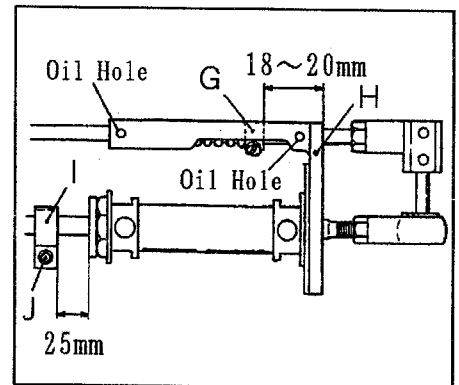



## 18. Adjustment of Automatic Thread Trimmer

Note : When operating Thread Trimmer manually, raise needles uppermost.

### 18-1 Position of Upper Knife Carrier

As Lower Knife Carrier(A) moves to the left, Upper Knife Carrier(B) also moves until it strikes against Positioning Stop(C) and stops. At this time, loosen Screw(D) and adjust the position of Supplementary Spring(E) to fix Upper Knife Carrier.

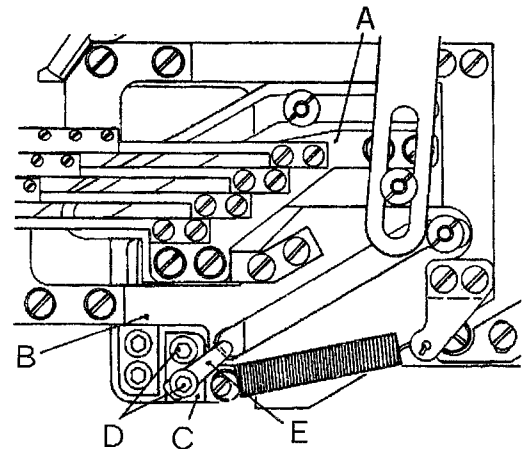

### 18-2 Position of each Lower Knife Carrier

Adjust so that each Lower Knives are parallel with each other. The adjustment is made by loosening Screws(F). Lengthwise pitch between each knives is 6.5mm. Check the pitch at the tips of each Lower Knives.

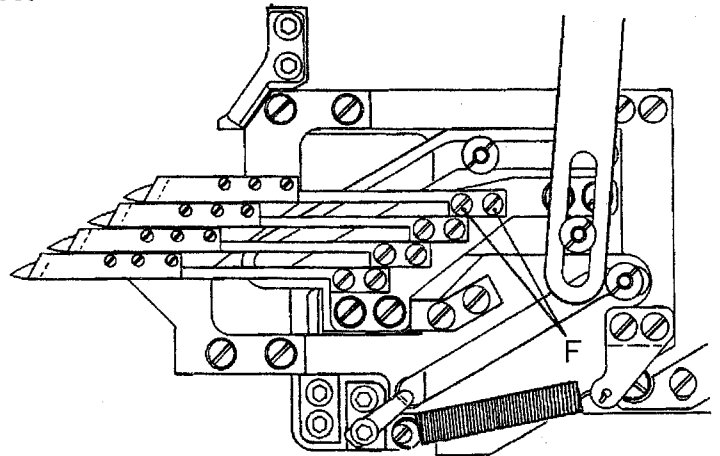

### 18-3 Position of tip of Lower Knife

With Loper at its extreme left position, when moving Lower Knife(G) to the left until its tip reaches 12mm from the right end of Loper, the tip of Lower Knife must be at the middle of breadth of Loper. The adjustment is made by loosening Screws of Upper Knife Carrier Stop(h) and Upper Knife Carrier Guide(Upper)(H).

At this time, make sure that it moves smoothly without gap. If it does not move smoothly, at the time of the above adjustment, adjust so that it moves smoothly by loosening Nuts(I) and (J).

After adjusting Nuts (I) and (J), adjust so that Knife Carrier returns to its home position keeping striking to Knife Carrier Guide(Front)(P).

The adjustment is made by loosening Screw(Q).

Note : After adjustment of Nuts (I) and (J), and Knife Carrier Guide(Front)(P), make sure that the whole Trimming Device moves smoothly without fail.

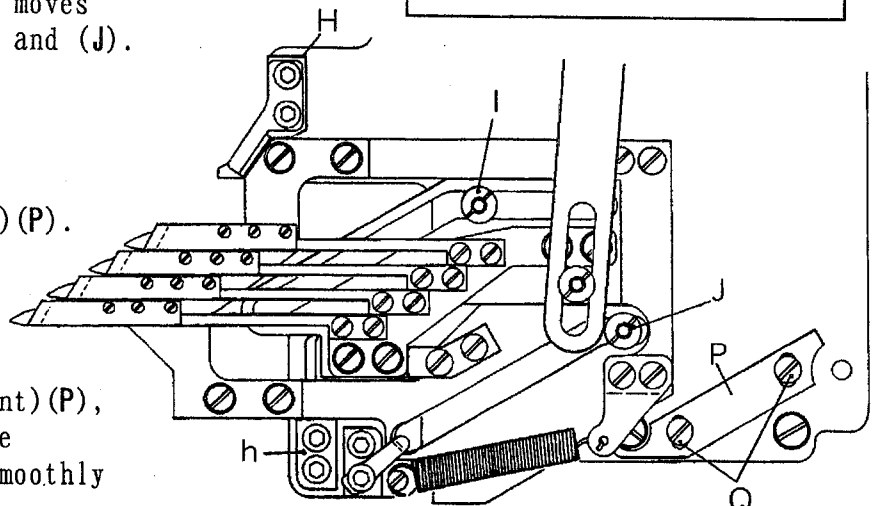
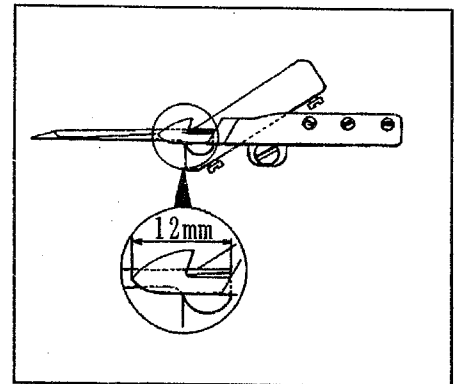

#### 18-4 Relation between Lower Knife and Needle

\* In case of Needle line-up style "X"  
With Lower Knife(G) at its extreme left position adjust the position of Block (N) so that Needle Thread Trimming Blade(K) is 5.5~6.5mm from the center of Needle. The adjustment is made by loosening Nuts(L) and (M) and moving Block(N) left and right.

\* In case of Needle line-up style "W" and "Y"  
With Lower Knife(G) at its extreme left position, adjust the position of Block(N) so that Needle Thread Trimming Blade(K) is 3.5mm~4.5mm from the center of left needle. The adjustment is made by loosening Nuts(L) and (M) and moving Block(N) left and right.

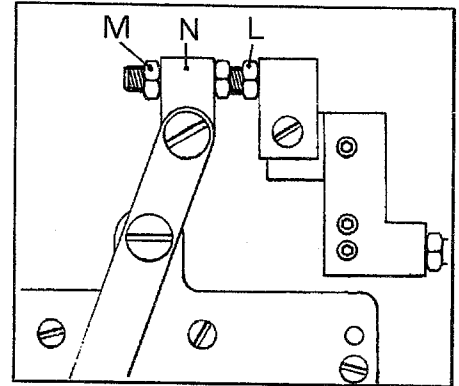
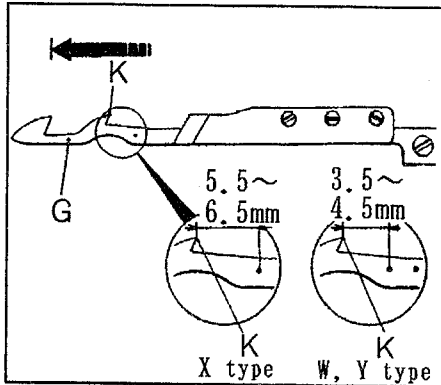

#### 18-5 Relation between Upper Knife and Lower Knife

Adjust so that the tip(K) of Needle Thread Trimming Blade of Lower Knife(G) pass the corner (o) of Upper Knife. The adjustment is made by loosening Screws(U) and (V) of Upper Knife.

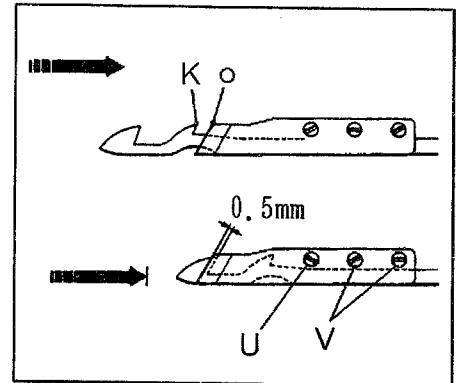

#### 18-6 Engagement of Upper Knife and Lower Knife

Adjust the engagement of Upper Knife(O) and Lower Knife(G) to 0.5mm by loosening Screw(F) of Lower Knife(G).

Note : Leave Screw(R) as it is.

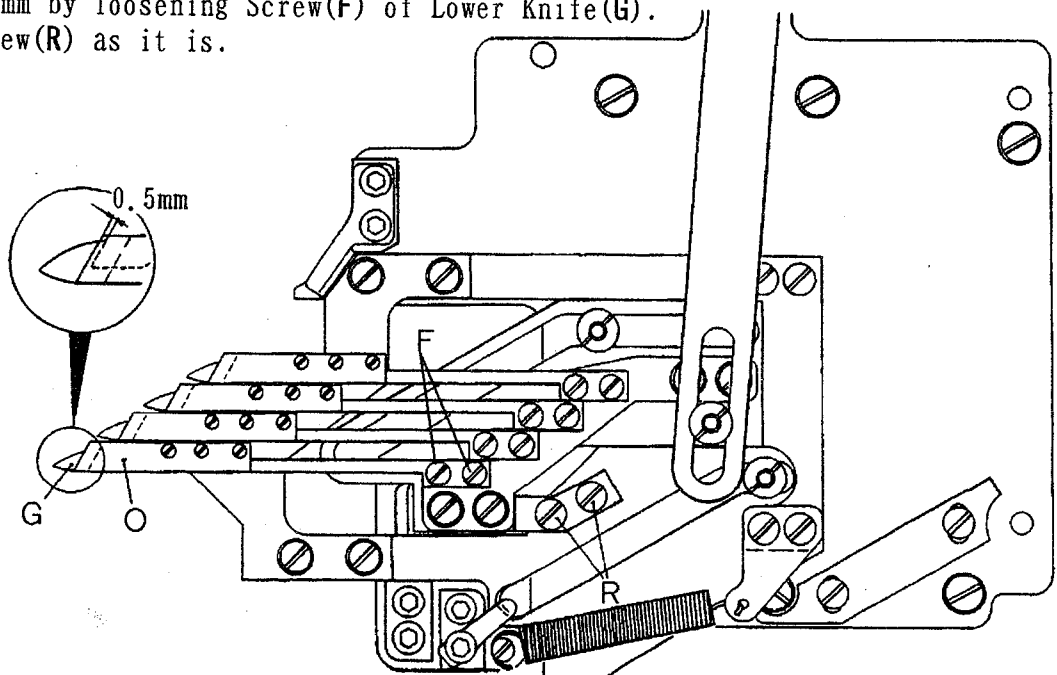

### 18-7 Position of Looper Thread Clamp Spring and Thread Clamp

As Lower Knife moves to the right and Needle Thread Trimming Blade of Lower Knife comes close to Clamp Spring(S), adjust so that surface(g'), back-surface of Clamp Spring(S) and the back-surface of Clamp Spring Adjusting Piece(T) are the same level.

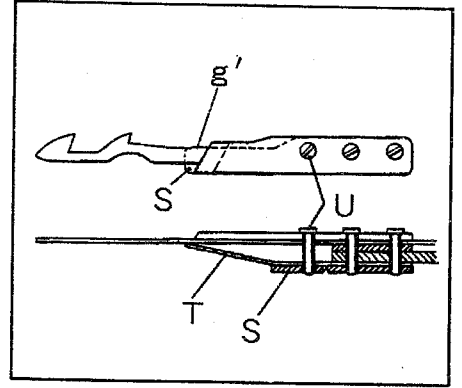

### 18-8 Pressure of Looper Thread Clamp Spring

After cutting, looper thread is held by Clamp Spring(S).

The adjustment of Clamp Spring is made by turning Adjusting Screw(U).

To strengthen, turn it to the right and to weaken, turn it to the left.

Note: If Adjusting Screw(U) is tightened too much, the durability of Knife will deteriorate.

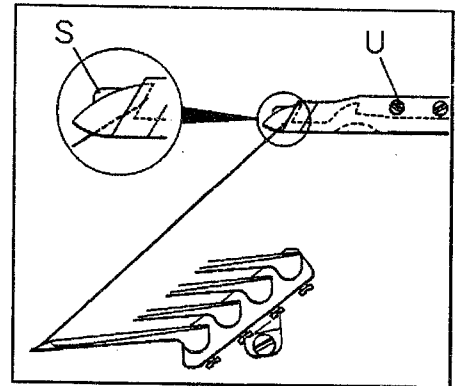

### 18-9 Relation between Lower Knife and needle thread, and looper thread

After finishing all adjustments, make sure the following points again before actual sewing.

- \* Lower Knife(G) must pass through the loop of needle thread, and Blade(g) for Trimming Looper Thread must pass in front of looper thread.
- \* During Lower Knife(G) returns after operation, needle thread and looper thread are pulled to the right by Blades(K) and (g), where they are cut by Upper Knife.

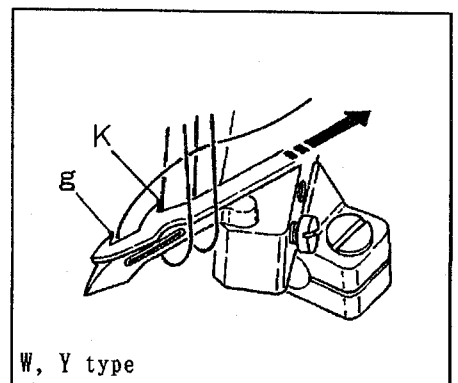
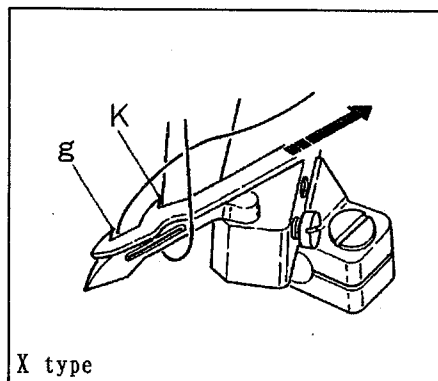
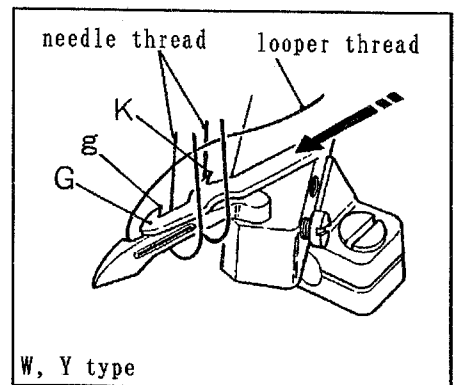
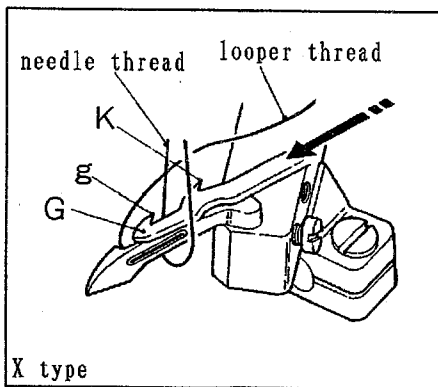

## 19. Adjustment of Tension Release Mechanism

Note : Pay attention to the possibility that when the air supply of this device is cut off because of adjustment or the like, Tension Release Mechanism shifts and Tension Disc lifts.

### 19-1 Tension Release Block

When Trimming Cylinder does not operate, provide a clearance of 1mm between Trimming Cylinder Support (A) and Tension Release Block (B) then tighten Screw (C).

Take care when the cylinder stroke is changed.

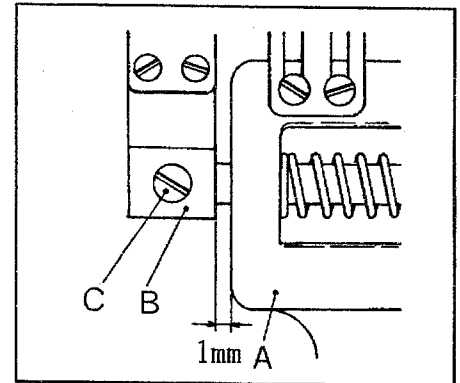

### 19-2 Tension Release Lever

Position Thread Pull-off Lever (E) so that Tension Disc opens as early as possible when Tension Release Cylinder (D) moves, and tighten Screw (F) of Tension Release Lever at the rear of Arm.

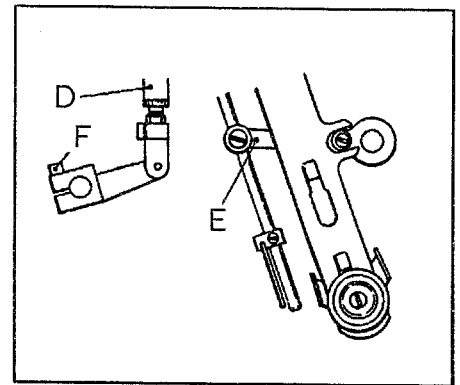

### 19-3 Tension Disc Separator

Adjust the position of Tension Disc Separator (I) so that Tension Disc opens as early as possible, by loosening Screw (H) of Tension Release Adjusting Eccentric (G).

Position upper end of Thread Pull-off Bar (J) 50mm from the surface of Thread Pull-off Bar Guide (K) and fix it to Thread Pull-off Bar Holder (L) with Screw (M).

### 19-4 Thread Pull-off Hook

Adjust the position of Thread Pull-off Hook (P) so that long needle thread does come out of undersurface of fabric at the sewing start. The adjustment is made by loosening Screw (O). To decrease the amount of thread pull-off, move Thread Pull-off Hook upward and to decrease, move it downward.

When not using this parts, raise it up to the position where it does not pull off the thread.

Note : If the thread pull-off is too little, seam is not formed at the start of sewing.

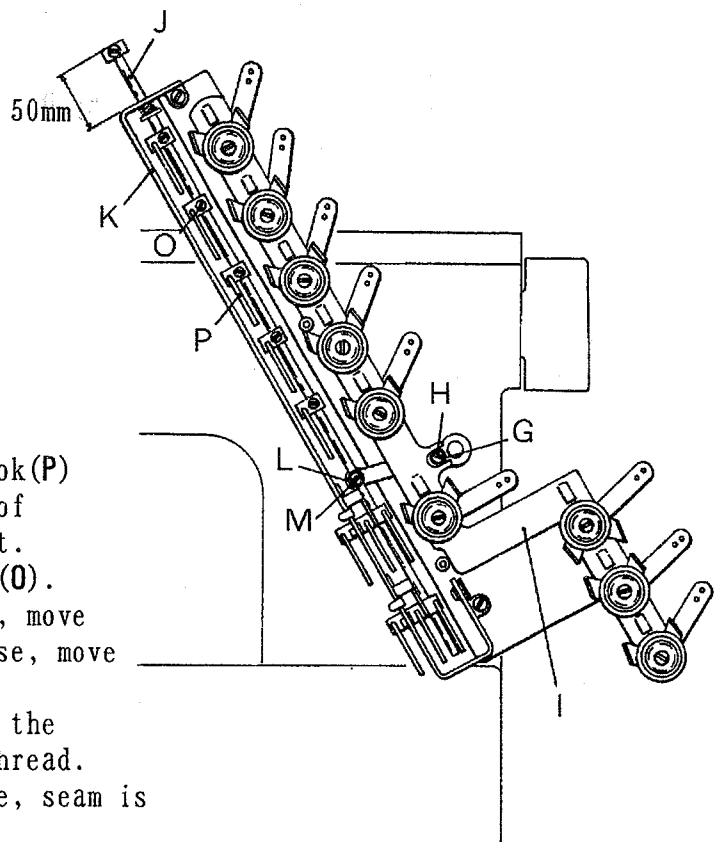

## 20. Adjustment of Air Wiper

With the needle at the uppermost position, set the center of Blowing Hole(H) of Air Wiper(G) 1~2mm lower than the center of Eye. As for lengthwise position, set Blowing Hole(H) at the rear of each needle. The adjustment is made by loosening Screw(I) and Nut(J).

Set the air amount as little as possible.

The adjustment is made with Speed Controller on Electromagnetic Valve.

To decrease, turn adjusting screw clockwise and to increase, counterclockwise.

If the air blows in front of needles, the needle thread may come off. Air must blow behind the needles.

Note : Because the blowing time is set to 1.5 sec., take out fabric immediately after thread trimming and lift up of Presser Foot.

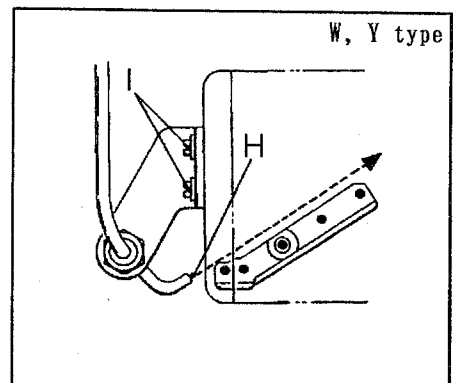
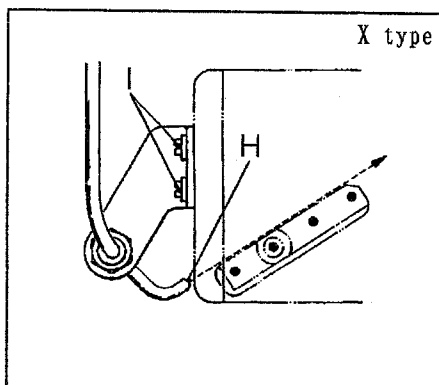
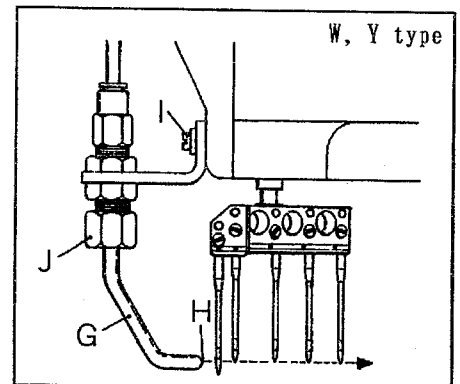
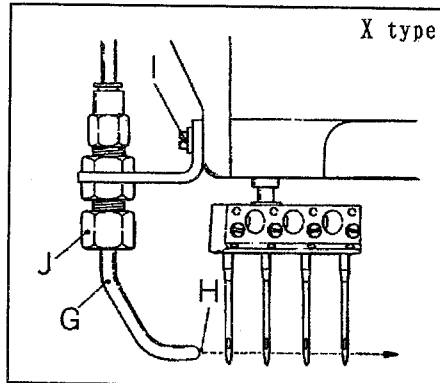

## 21. Adjustment of Presser Foot Lifter Device

When Cylinder Rod(D) is at its uppermost position (when Cylinder does not operate), provide a clearance of 0.5mm between Cylinder Rod Chip(E) and Lifter Lever(F).

The adjustment is made by loosening Lock Nut(G) and turning Cylinder Rod Chip(E).

Next, when Cylinder Rod(D) is lowered (when Cylinder does operate) adjust the position of Collar(I) so that Presser Foot rises by 8mm, by loosening Screw(H).

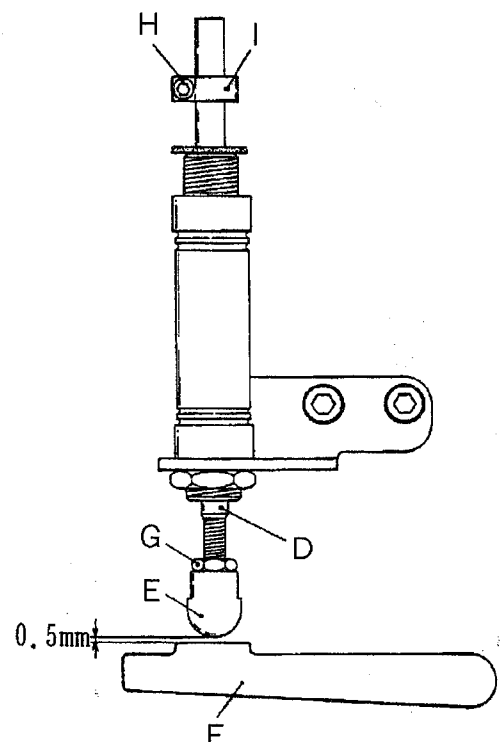
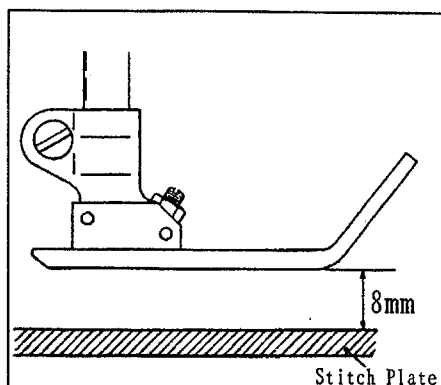

## 22. "AS4" Device

"AS4" is a device to open or close Elastic Tape Guide and Folder by pressing Knee Switch lightly.

## 23. "AR10" DEVICE

### 23-1 Air piping and wiring

When using "UT-A50" Device together with "AR10" Device, change air piping and wiring as shown in the illustration below.

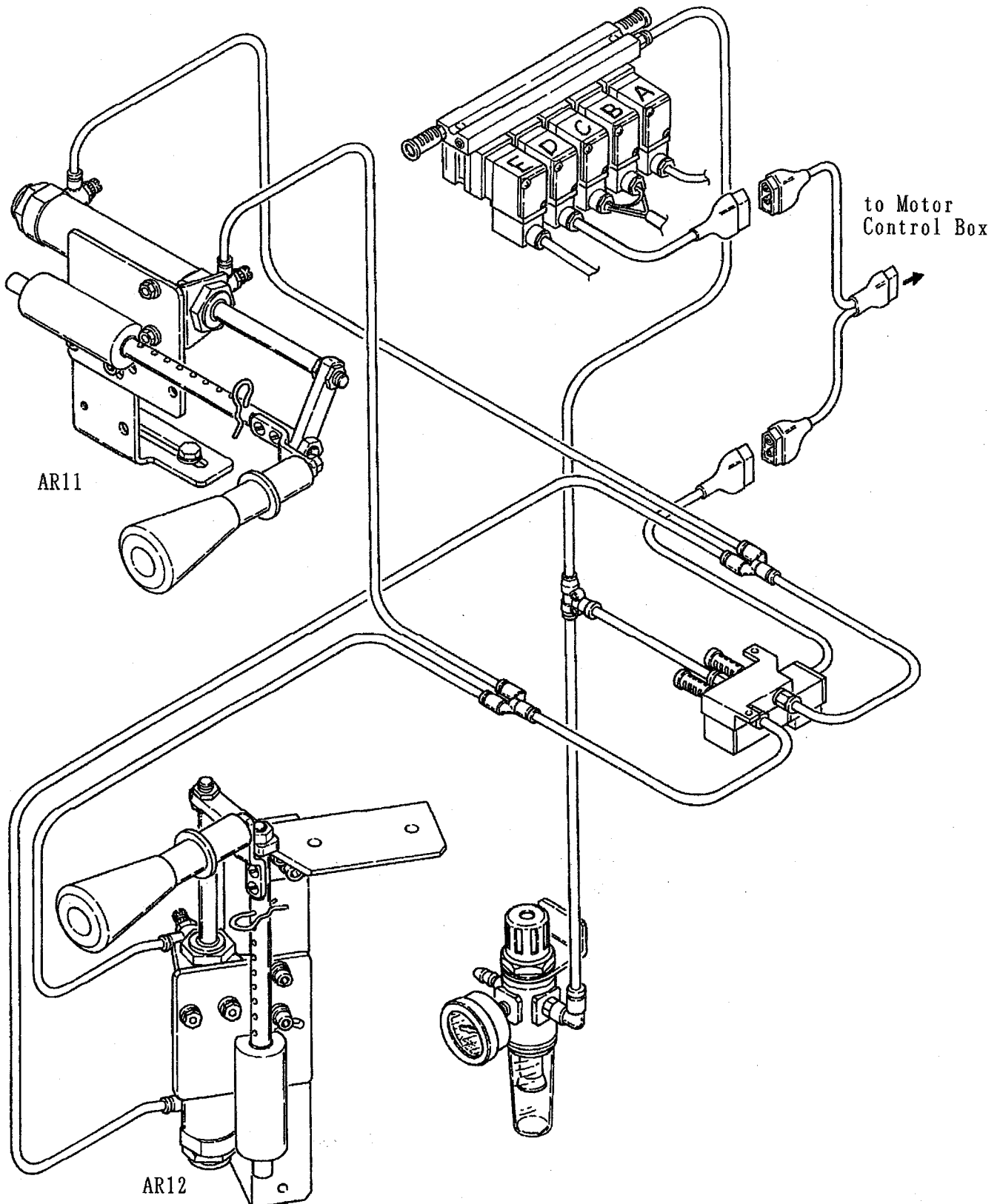

### 23-2 Illustration for installing AR11 and AR12 Device

Drill 2 setting holes( $\phi 9$ ) for AR11 Device and install the device on table top with Bolts, Washer and Nuts.

Install AR12 Device using Wood Screws and Washers on the undersurface of table.

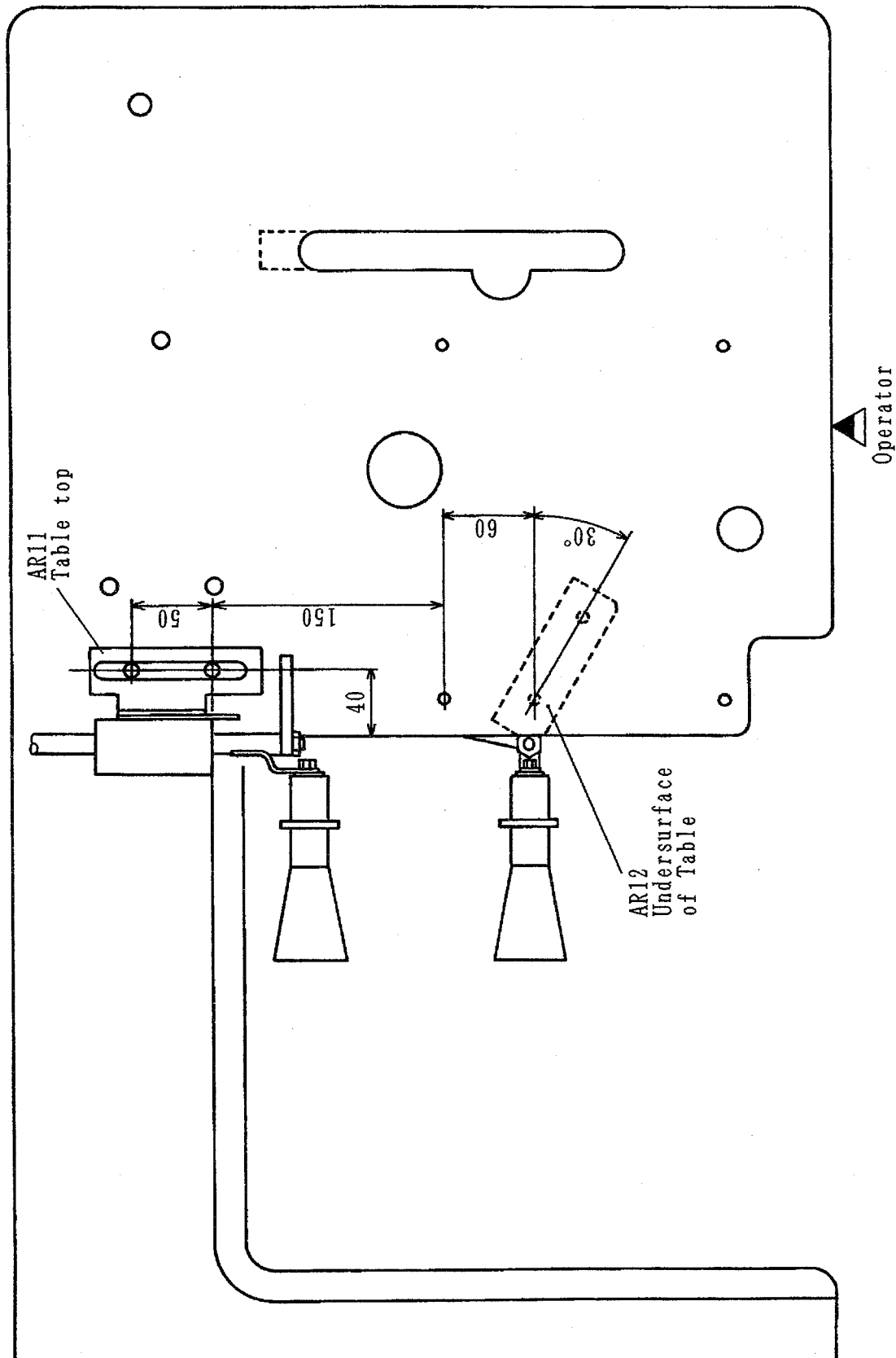

***Yamato***

ヤマトマシン製造株式会社

***YAMATO SEWING MACHINE MFG. CO., LTD.***

4-4-12, NISHITENMA, KITA-KU, OSAKA, JAPAN  
TEL: 81-6-6364-1321 FAX: 81-6-6364-1307

〒530-0047 大阪市北区西天満4丁目4番12号  
TEL(06)6364-1321(代) FAX(06)6365-5176