

Yamato®

INSTRUCTIONS FOR “EU20” & “AU20” DEVICE

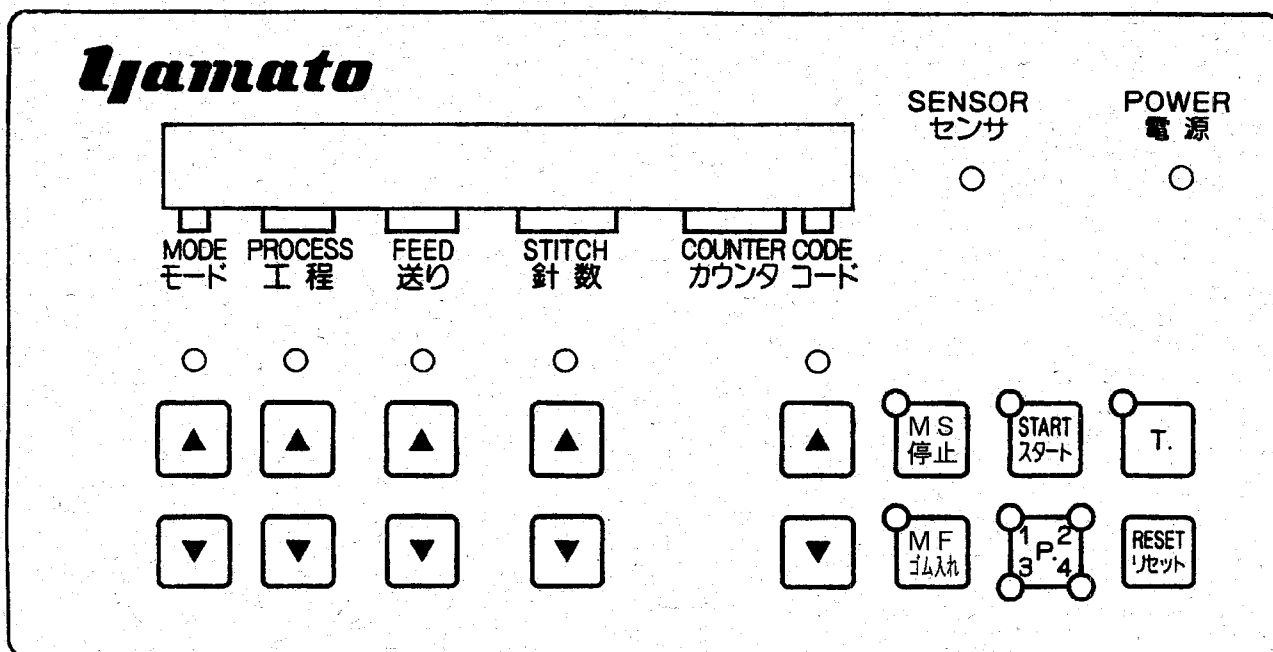

CONTENTS

	Page
1. Installation of Control Box	1
2. Wiring to Power Box	2
3. Designation and function of Control Panel	3
3-1 Explanation of Control Panel	3
4. Kind of data	7
4-1 Data for Timer, etc.	7
4-2 Data of Switches	8
4-3 Data of function	8
5. Examples of usage	9
5-1 Setting of Timer Message	9
5-2 Example of setting for sewing	10
6. Adjustment of "EU20" Cutter Device	15
6-1 Adjustment of Upper Cutting Knife	15
6-2 Engagement strength of Upper and Lower Cutting Knife	16
7. Adjustment of "AU20" Cutter Device	17
7-1 Adjustment of cutting angle of Knives	17
7-2 Adjustment of Upper Cutting Knife pressure	17

1. Installation of Control Box

Bore setting hole($\phi 16$) for Control Box referring to the illustration.
And install Control Box.

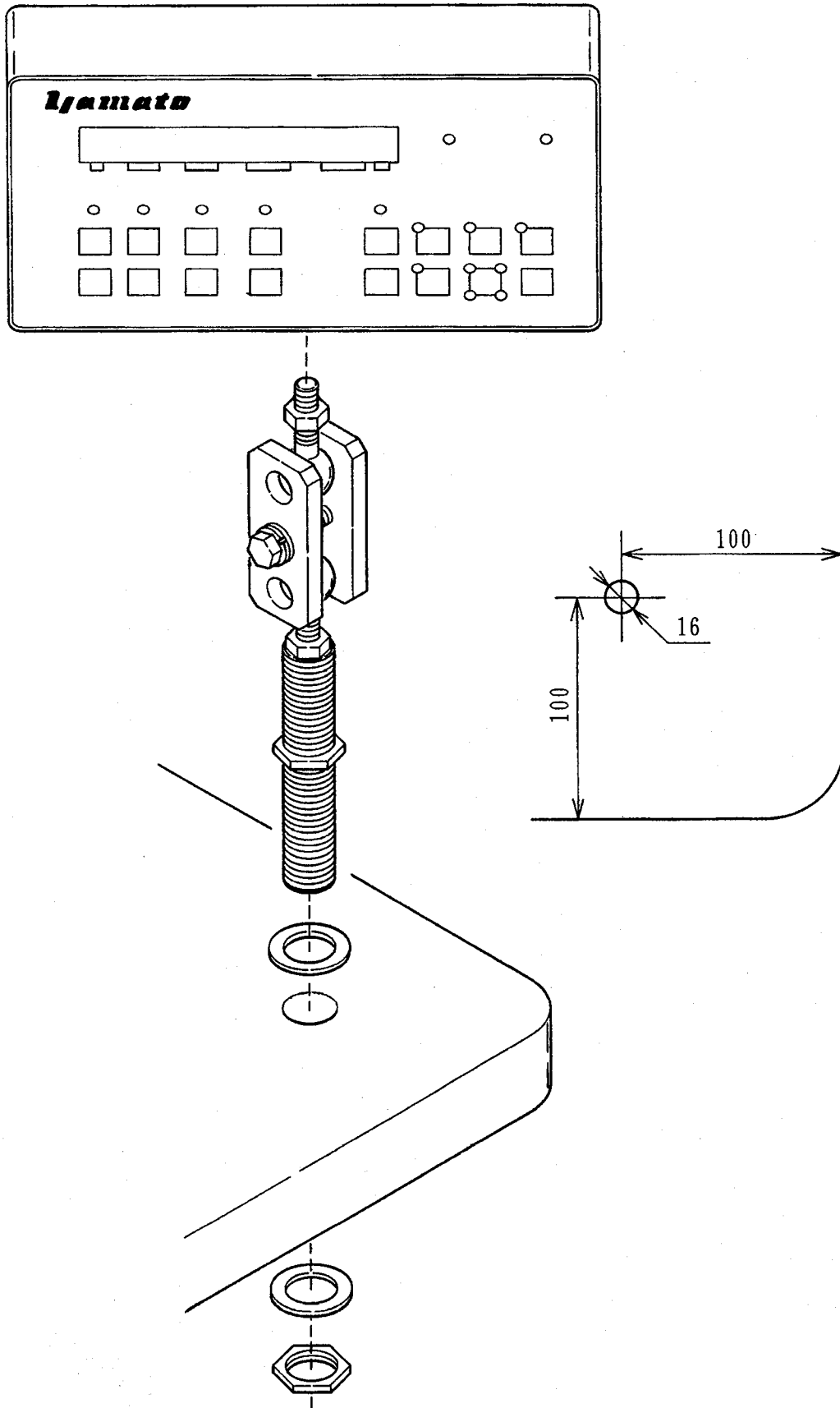

2. Wiring to Power Box

Connect each connectors to the corresponding ones.

The standard power voltage is 200V. In case of using other power voltage, exchange pins of transformer inside.

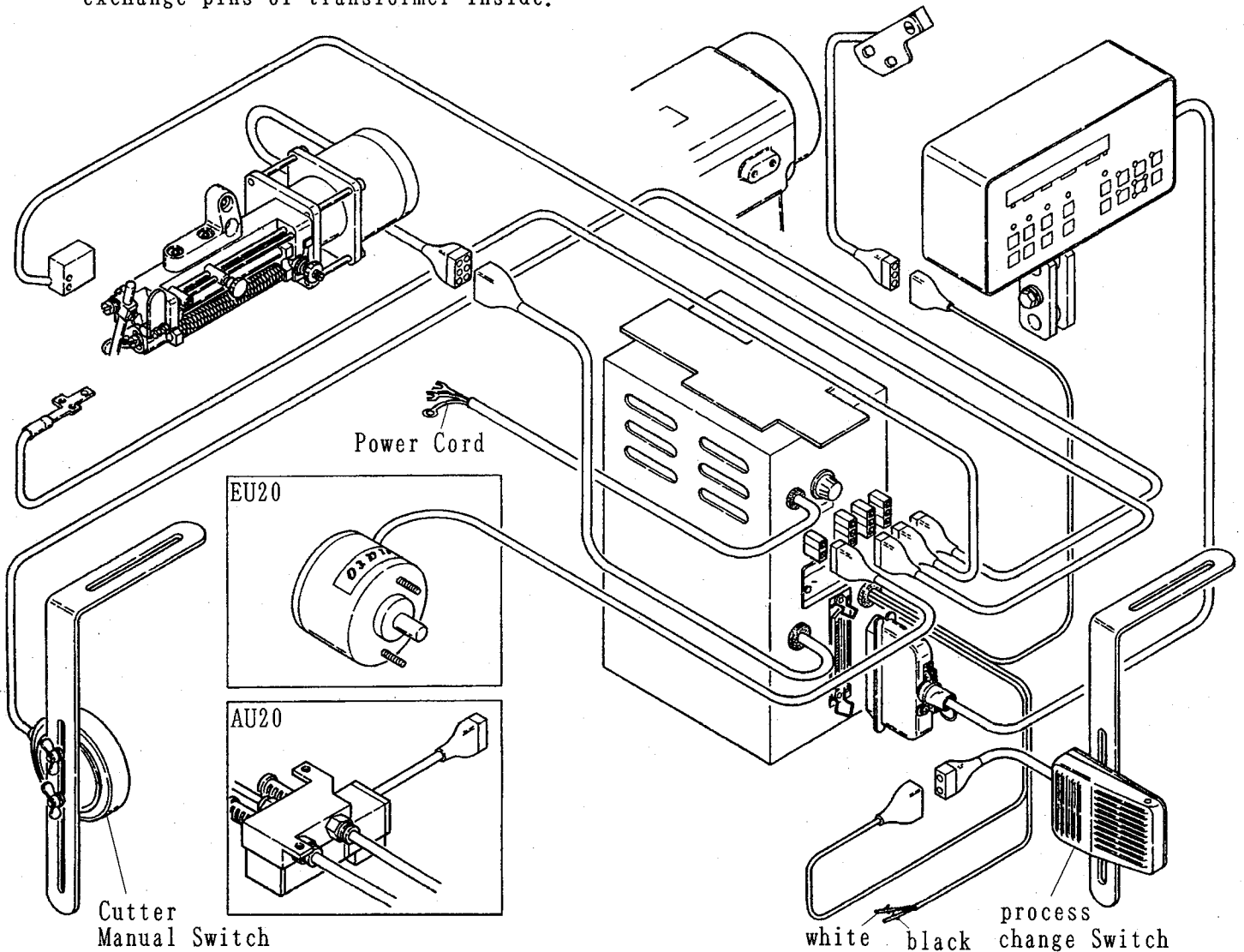

* Connection of Power Cord

Connect red and black cords to Power Switch.

Green cord is an earth line and connect it to another Screw as shown in the illustration below.

* In case of auto-stopping by using Electronic Motor

white pin.....insert into the stop signal of Electronic Motor.

black pin.....insert into "0V" of Electronic Motor.

Note: When connecting cords to Power Switch, connect them to motor side terminals

Change Power Fuse according to the voltage, select the capacity of fuse referring to the table below.

power voltage	capacity of fuse
100V	4A
200V	2A
220V	2A
380V	1A

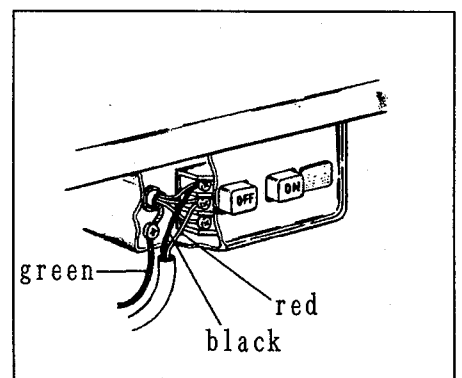

3. Designation and function of Control Panel

Mode A~Z can be used for this machine and each mode can be divided into 20 processes. A mode corresponds to one work piece and the process can be set every time the pulling amount changes.

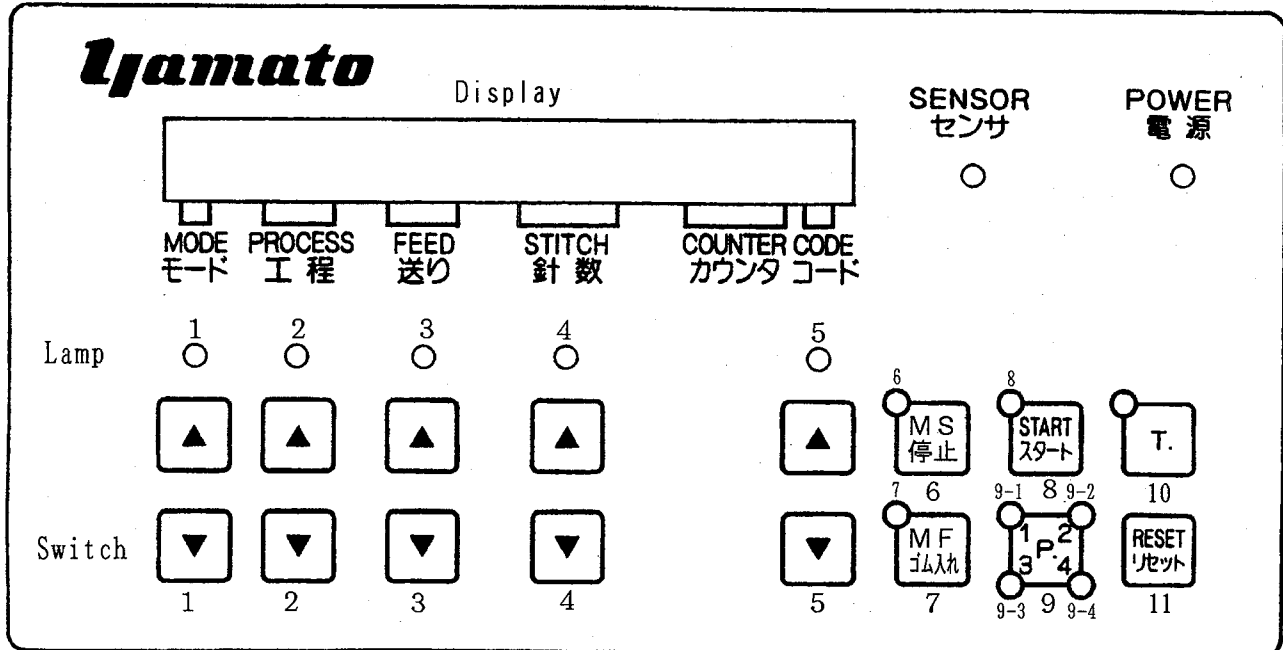

3-1 Explanation of Control Panel

(1) Display

This part shows the present control condition by the numerals and alphabets displayed on this part.

(2) Lamp(1, 2, 3, 4 and 5)

The Switches under the lighted lamp can be actuated.

(3) Switches

When pressing ▲ of the following Switches the number increases and pressing ▼ the number decreases.

* Mode Switch(1)

Mode A~Z can be selected by this Switch.

* Process Switch(2)

Process changes from 1 to 20 by this Switch. At the same time, feed amount, needle number and code at that process are displayed.

At the teaching, the set feed amount, needle number and code are memorized by pressing this Switch.

* Feed Switch(3)

Feed amount can be changed by this Switch. By pressing this Switch continuously, the number increase or decrease at high speed automatically.

* Stitch Number Switch(4)

Stitch number can be changed by this Switch. By pressing this Switch continuously, the number increases or decreases at high speed automatically.

* Code Switch(5)

Code can be changed by this Switch.

This code determines the cutting time—at sewing start or sewing finish; or determines whether process change should be made by Knee Switch or by stitch number.

Code	process change	Cutter at sewing start	Cutter at sewing finish	function, etc.
A	Knee Switch	OFF	OFF	By detecting sewing finish, the process proceeds to the next process.
B	Knee Switch	ON	OFF	By detecting sewing finish, the process proceeds to the next process.
C	Knee Switch	OFF	ON	By detecting sewing finish, the process proceeds to the next process. Cutting at the sewing finish after stopping of machine. ※1
D	Knee Switch	ON	ON	By detecting sewing finish, the process proceeds to the next process. Cutting at the sewing finish after stopping of machine. ※1
E	stitch number & Knee Switch	OFF	OFF	Count when fabric covers Sensor.
F	stitch number & Knee Switch	ON	OFF	Count when fabric covers Sensor.
G	stitch number & Knee Switch	OFF	ON	Count when fabric covers Sensor. Cutting at the sewing finish after stopping of machine. ※1
H	stitch number & Knee Switch	ON	ON	Count when fabric covers Sensor. Cutting at the sewing finish after stopping of machine. ※1
I	stitch number & Knee Switch	Regardless of Optical Sensor, always count when machine is rotating. After counting out, the machine stops. ※1		
J	stitch number & Knee Switch	Regardless of Optical Sensor, always count when machine is rotating. Cutting after counting out and stopping of machine. ※1		
K	stitch number & Knee Switch	Regardless of Optical Sensor, always count when machine is rotating. Cutting at the sewing finish after stopping of machine.		
■	When setting this code, this process does not operate, instead it returns to 1st process . But during sewing, it keeps feeding amount of previous process and when the machine stops it returns to 1st process for example, when the sewing finishes at 3rd process, it must be set Code ■ for 4th process.			

(※1) Machine stops only at the time of using Electronic Motor and set the data number 01 of function to 1. And at the time of teaching, Cutter does not operate by code J or K. At this time operate the cutter manually.

(※2) The above Code I, J and K should be used only when using Electronic Motor.

- * Motor Stop Switch(6)
When pressing this Switch, **V F 2 4 2 9 0 0 0 0 RPM** appears on display and Lamp 6 lights. And at the sewing, Feed Motor does not rotate, and the r.p.m. at that time is displayed.
- * Tape Insert Switch(7)
While pressing this Switch, Feed Motor rotates.
- * Start Switch(8)
When pressing this Switch, Lamp 8 lights. (It is in this condition when power Switch is turned on.)
Sewing is possible when this Lamp lights. At this time, the process can be changed.
- * P. Switch(9)
When the machine stops, if this Switch is pressed, Lamp 9-1, 9-2, 9-3 and Lamp 9-4 lights in this order.
- ☆ Lamp 9-1
When this Lamp lights, mode, process, feed, stitch number and code can be changed. The change is made by pressing Switch 1, 2, 3, 4 and 5.
- ☆ Lamp 9-2
The display changes and data of Timer can be changed. (Refer to 4-1.)
Example : **T-00 FRONT 05**
Timer number can be changed by Process Switch(2) and Timer data can be changed by Code Switch(5)
- ☆ Lamp 9-3
The display changes and the data of switch can be changed. (Refer to 4-2.)
Example : **S-00 H. FEED 0**
Switch number can be changed by Process Switch(2) and 1, 0 of the switch can be be changed by Code Switch(5).
- ☆ Lamp 9-4
The display changes and various functions can be selected. (Refer to 4-3.)
(This can be done only when Switch 4 is turned ON. (turn upward.)
Example : **F-00 ENGLISH 1**
Function number can be changed by Process Switch(2) and Function Selection can be changed by Code Switch(5).
- * T. Switch(10)
Change Switch to teaching mode.
When pressing this, Lamp 10 blinks.
When Lamp 8 and Lamp 10 light, it operates as teaching mode.
Feed and code can be set while sewing.
When process change is made by stitch number automatically, (Code E, F, G, H, I, J, and K) counter(indicate stitch number) on display increases by sewing.
And the number of counter is memorized by pressing process Switch(2).
(Former number is renewed.)
- * Reset Switch(11)
If this Switch is pressed when machine stops, the process returns to "1".

(4) Sensor Lamp

This lamp lights when Sensor (Emission Catcher) is covered with fabric and puts off when uncovered.

Sensitivity adjustment of Sensor is made by VR3 in Power Box.

- ① Align the axes of Light Emitter and Emission Catcher.
- ② Return the variable resistor VR3 to "0".
- ③ Turn VR3 clockwise stowly to light Sensor Lamp and set it beyond 0.5~1 graduation further.

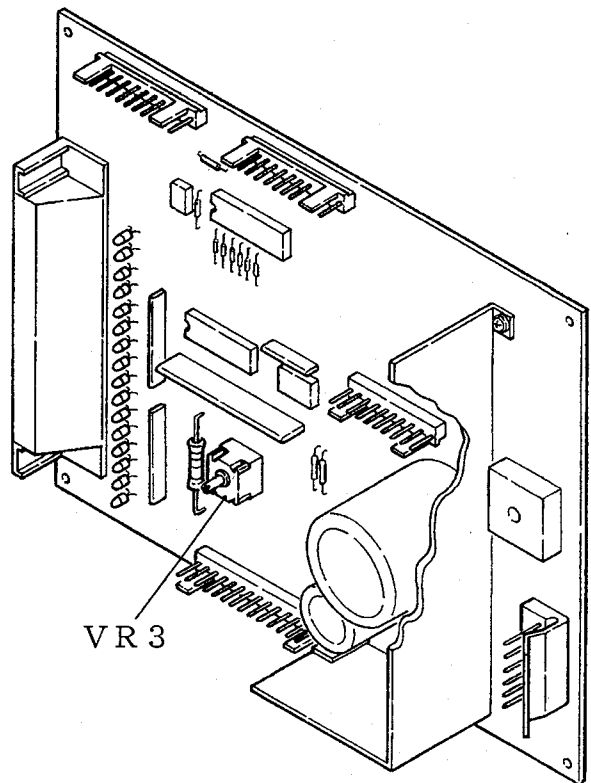

(5) Power Lamp

This lights when power is turned on.

(6) Inner Switch(in Control Box)

Switch(1) no use

Switch(2) no use

Switch(3) AU Device (ON) /EU Device (OFF)

When Power is turned on, this indicate whether the program operates as AU Device or as EU Device according to the condition of this Switch.

Adjust it to the machine to be used.

Switch(4) P.4 Reception possible(ON)/ Impossible(OFF)

"ON" indicates turning this Switch upward condition.

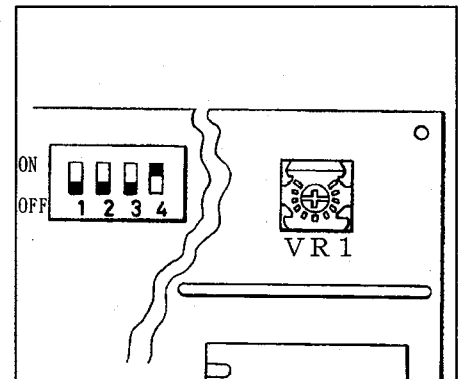

(7) VR1

Adjust brightness and Contrast of display.

4. Kind of data

There are 20 items for each, but items other than below are spare.

4-1 Data for Timer, etc. (2 digits of the left number is Timer No.)

Display

- | | |
|---|-----------------|
| ☆ Stitch number from the detection of sewing start to the operation of Cutter. | T-00 FRONT |
| ☆ Stitch number from the detection of sewing finish to the operation of Cutter.
(In case of using an electronic motor, Cutter operates after counting out this stitch number.) | T-01 REAR |
| ☆ Operating time of EU 20 Device.
0.025 second for 05 and 0.05 second for 10. | T-02 CUTTER TIM |
| ☆ Set number on this Timer when sewing mesh material.
If Cutter mal-functions, increase the number. | T-03 MESH TIM |
| ☆ In case of using electronic motor, this sets the time from the stop of machine to the operation of Cutter.
Set it 3~6.
The smaller the number, the earlier the Cutter operates after the stop of machine.
With too small the number, the Cutter will operate before the stopping of machine. | T-04 STOP TIM |
| ☆ Correction of feed amount for the speed over 3,000 r.p.m.. | T-05 COR. 3000 |
| ☆ Correction of feed amount for the speed over 4,000 r.p.m.. | T-06 COR. 4000 |
| ☆ T-07~T-19 is spare. | |

4-2 Data of Switches

Display

☆ 1...Greater speed of Feed Motor at the sewing.

S-00 H. FEED

0...Lesser speed of Feed Motor at the sewing.

It shows the stitch length (mm/stitch) fed by motor when feed amount is set from 00 to 99.

But it is only standard and varies according to the fabric to be sewn.

feed amount	stitch length (for 1) (mm)	stitch length (for 0) (mm)
00	1	0.36
10	1.32	0.68
20	1.63	1
30	1.94	1.32
40	2.26	1.63
50	2.58	1.94
60	2.89	2.26
70	3.20	2.58
80	3.52	2.89
90	3.83	3.20

☆ S-01~S-19 is spare.

4-3 Data of function

☆ Selection of English(1) or Japanese(0) on display.

F-00 ENGLISH

☆ Using of Electric Motor(1)

Using of Clutch Motor(0)

If it is not set correctly, there may be cases that cutter does not operate or machine does not stop at sewing finish.

F-01 ELE MOTOR

Note: When set to 1, connect stop signal line in Power Box to the stop command input of Electronic Motor without fail.

☆ F-02~F-19 is spare.

5. Examples of usage

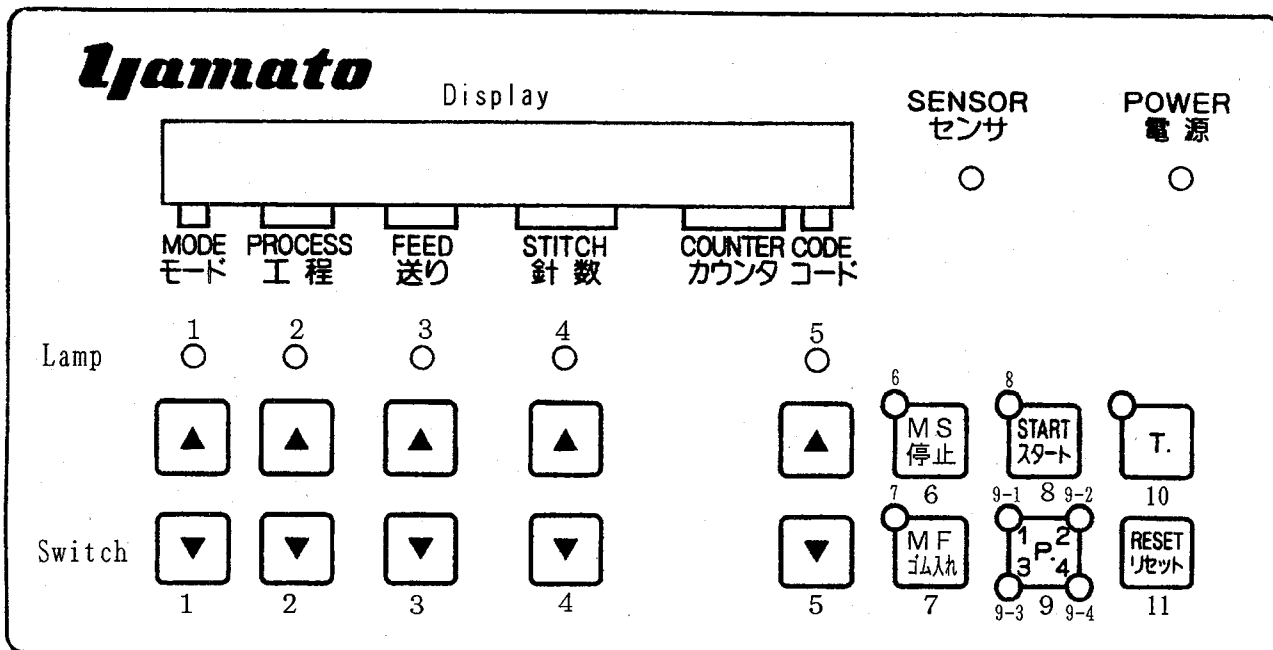

5-1 Setting of Timer Message (Example of display is shown to the right.)

- | | |
|--|------------------|
| ① Turn on Power Switch. | A 01 30 A |
| ② Press P. Switch(9) twice.
Data of Timer, etc. can be changed. | T-00 FRONT 00 |
| ③ Press Code Switch(5) to display 05. | T-00 FRONT 05 |
| ④ Press Process Switch(2). | T-01 REAR 00 |
| ⑤ Press Code Switch(5) to display 15. | T-01 REAR 15 |
| ⑥ Press Process Switch(2). | T-02 CUTTER 00 |
| ⑦ Press Code Switch(5) to display 10. | T-02 CUTTER 10 |
| ⑧ Press Process Switch(2). | T-03 MESH 00 |
| ⑨ Press Code Switch(5) to display 10. | T-03 MESH 10 |
| ⑩ Press Process Switch(2). | T-04 STOP TIM 00 |
| ⑪ Press Code Switch(5) to display 05.
That sets 5 stitch for FRONT 15 stitch of REAR 10(0.05sec) for CUTTER 10 for MESH and 5 for STOP TIM. | T-04 STOP TIM 05 |
| ⑫ Press P. Switch(9).
With that, data change of switch becomes possible. | S-00 H. FEED 0 |
| ⑬ Press Code Switch(5). | S-00 H. FEED 1 |
| ⑭ Press P. Switch(9).
With that, data change of function becomes possible. | F-00 ENGLISH 1 |
| ⑮ Press Process Switch(2). | F-01 ELE MOTOR 0 |
| ⑯ Press Code Switch(5). | F-01 ELE MOTOR 1 |
| ⑰ Press Start Switch(8). | A 01 30 A |

With that, feed speed is set to faster side and Electronic Motor specification is set.

5-2 Example of setting for sewing

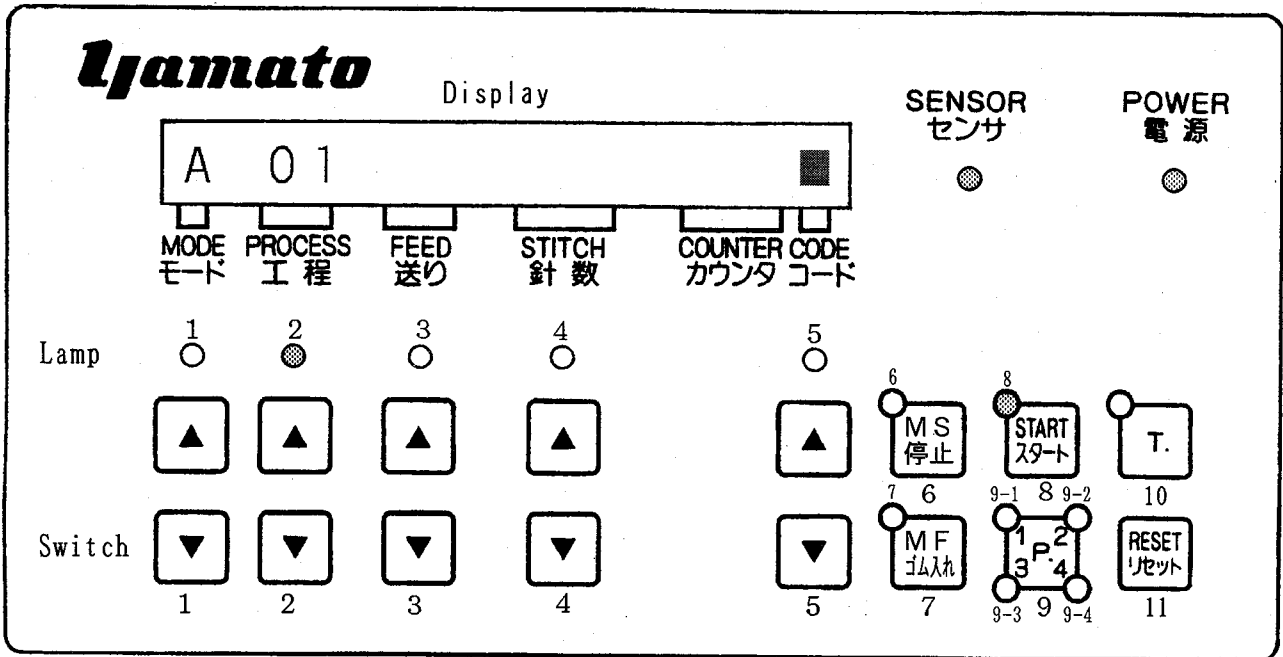

(Fig. 1)

●...Light-on ○...Light-out

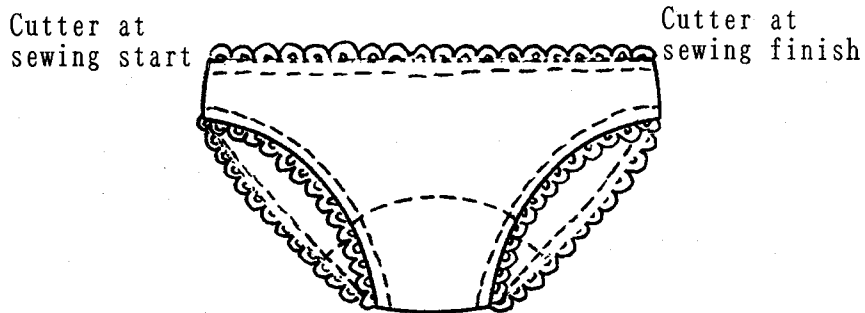

(Example 1)

Using only one kind of feed amount and operate Cutter at sewing start and sewing finish.

Set Control Panel following the procedure below:

1. Turn "ON" Power Switch.
2. Lamps on Control Panel of Power, Sensor, Process and sewing start light. (Fig. 1)

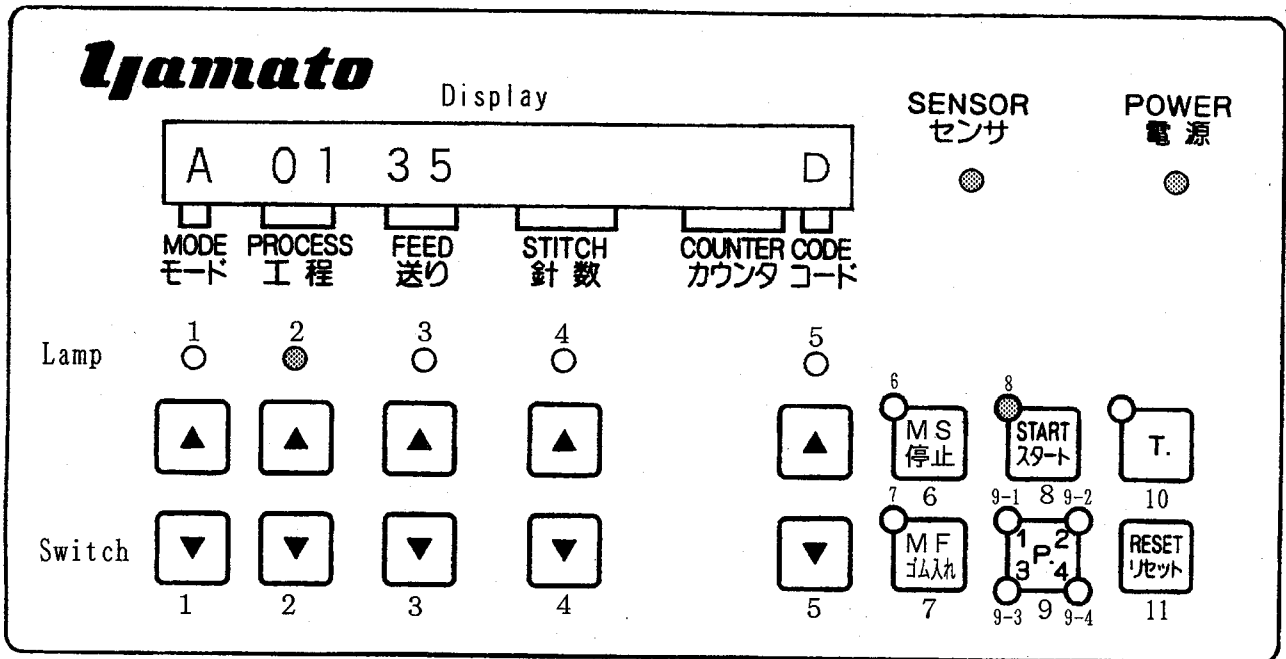

(Fig. 3)

●...Light-on ○...Light-out

6. Make sewing test.
Set suitable feed amount by operating Feed Switch(3) to ensure the proper feed amount of elastic tape against garment body while sewing.
7. Set Process to 02 by pressing Process Switch(2).
8. Press T. Switch(10) to conclude teaching.
(Fig. 3)

A 01 35 D

A 02

A 01 35 D

Next sewing is made by only turn Power on.

Note : When turn Power on, the condition before turning off of Power is displayed.

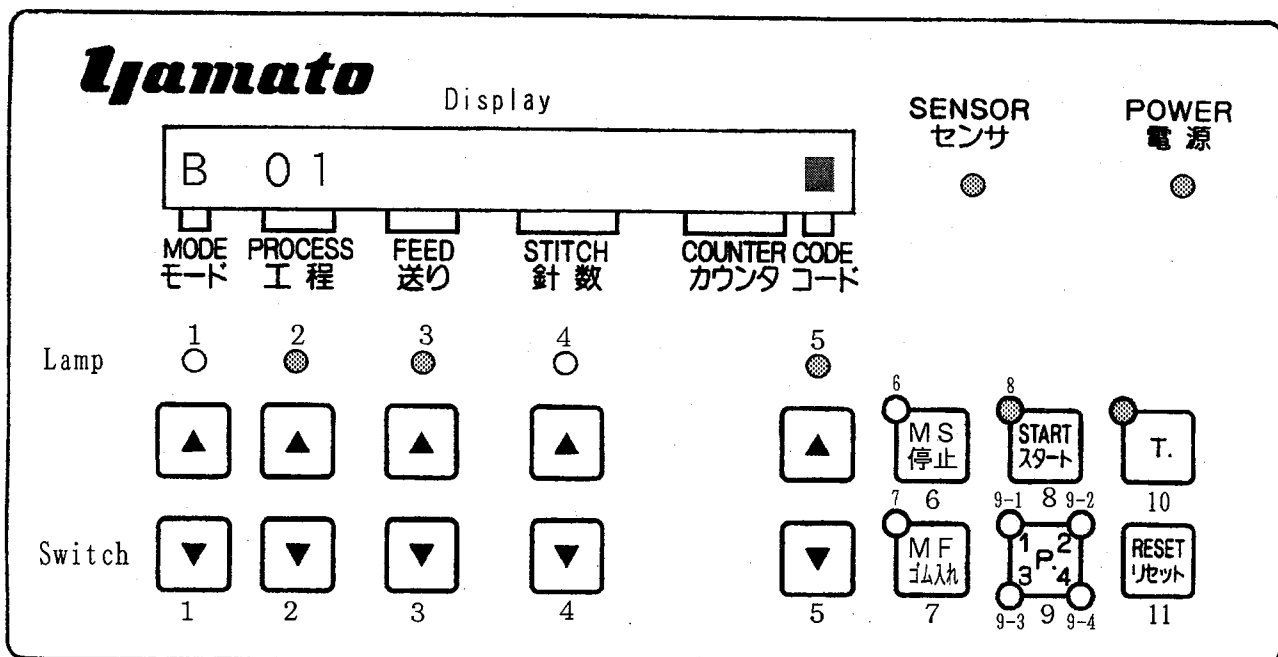

(Fig. 4)

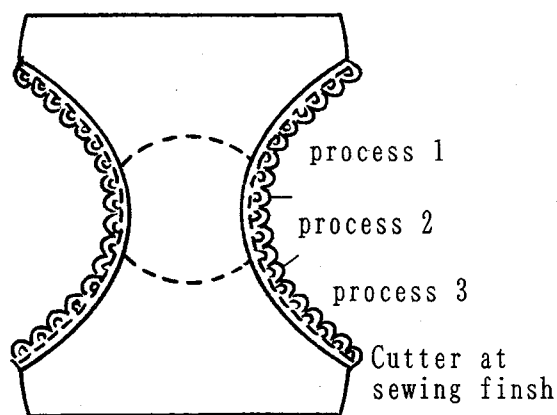

(Example 2)

When sewing leg hole, use 3 kinds of feed amount and operate Cutter at sewing finish.

In case of applying three kinds of feed amount and operating "Rear Cut", use mode B and change the process by counter to 2nd process.

Set Control Panel following the procedure below:

1. Turn "ON" Power Switch.
2. Press P. Switch(9).
3. Press Mode Switch(1) to get mode B.
4. Press Start Switch(8).



With that, the mode is set to B.

5. Press T. Switch(10) to make it "teaching". (Fig. 4)



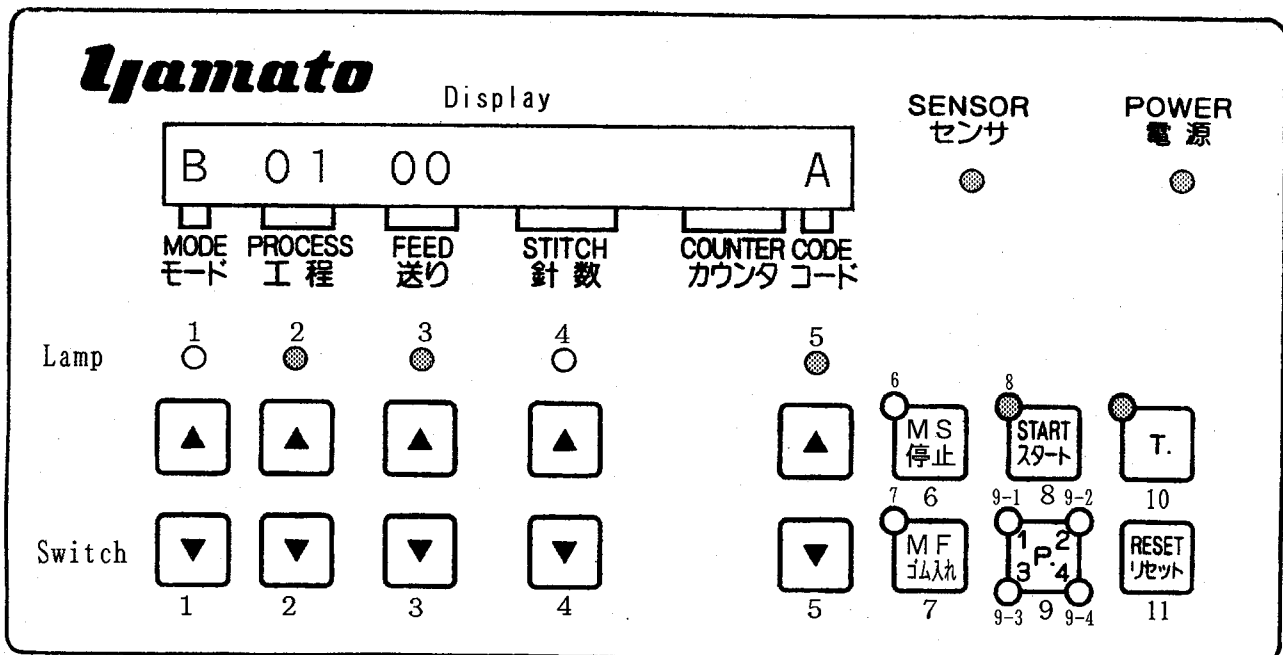

(Fig. 5)

Setting of 1st process

6. Set the code to A by Code Switch(5).
(Fig. 5)

B 01 00 A

7. Adjust Feed Switch(3) while sewing.

B 01 37 A

8. After that, press Process Switch(2) to set 2nd process.

B 02

Setting of 2nd process

9. Set the code to E by Code Switch(5).

B 02 00 000 000E

10. Adjust Feed Switch(3) while Sewing.

B 02 02 000 045E

11. After that, press Process Switch(2) to set 3rd process.
(By doing so, the numeral of counter is memorized.)

B 03

Setting of 3rd process

12. Set code to C by Code Switch(5).

B 03 00 C

13. Adjust Feed Switch(3) while Sewing.

B 03 34 C

14. After that, press Process Switch(2) to set process to 4.

B 04

15. Press T. Switch(10) to finish teaching.

B 01 37 C

Next sewing is made by only turn Power on.

Note : When turn Power on, the condition before turning off Power is displayed.

6. Adjustment of "EU20" Cutter Device

6-1 Adjustment of Upper Cutting Knife

Loosen Screw(A) and provide a clearance of about 4mm between Upper Cutting Knife Connecting Lever(B) and Upper Cutting Knife Holder(C), then tighten Screw(A) tentatively. (Refer to the illustration, Viewed from(X).)

Next, energize Solenoid and make sure that when Cutter(Upper) descends, corner (d) of Upper Cutting Knife is flush with undersurface of Cutter(E) as illustrated.

If it is not, adjust by loosening Screw(A) and moving Connecting Lever(B).

(When energize Solenoid after descending Cutter(Upper) (D) manually lowermost, the position of Cutter(Upper) can be seen correctly.)

After adjustment, fix Connecting Lever(B) with Screw(A).

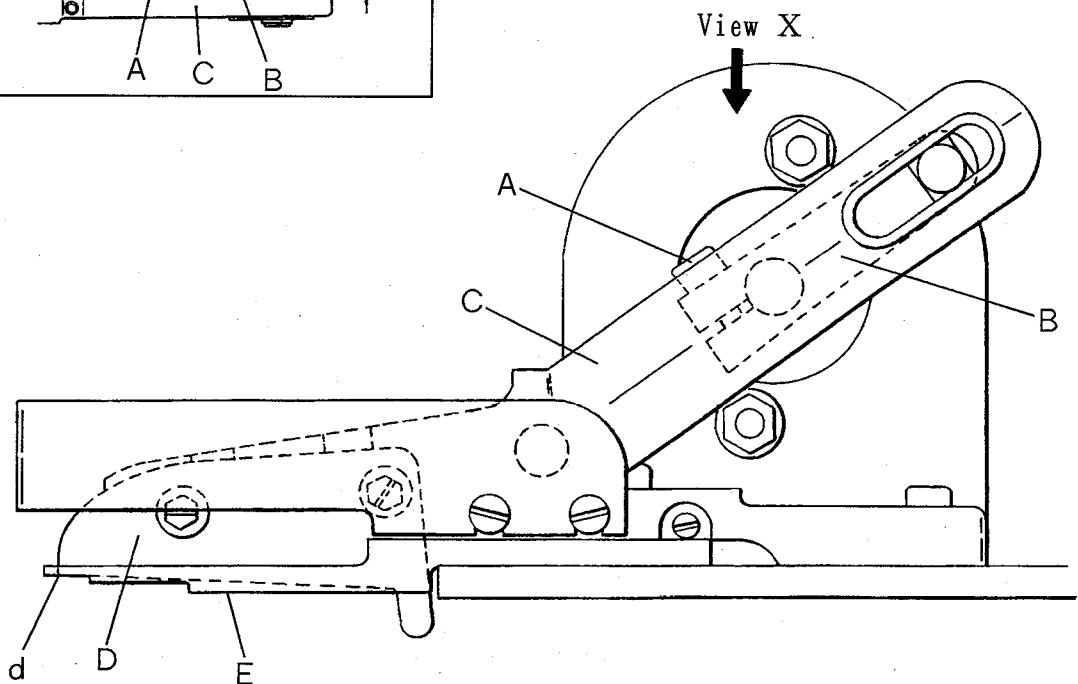
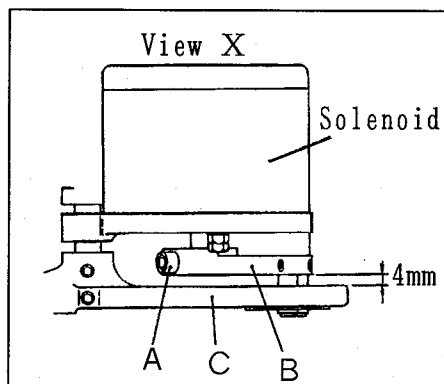

6-2 Engagement strength of Upper and Lower Cutting Knife

- ① The adjustment of engagement strength of Upper Cutting Knife(D) and Lower Cutting Knife(E) is made by loosening Screw(F) and turning Screw(G).
When turning Screw(G) to the right (direction R), Lower Cutting Knife shifts to direction(r) and the strength of engagement becomes weak; and turning Screw(G) to the left (direction L), Lower Cutting Knife shifts to direction(l) and the strength of engagement becomes strong.
- ② The adjustment of pressure to press Upper Cutting Knife is made by loosening Screw(J) for Cutter(Upper) Press Spring Collar(H).
The proper position of Pressing Spring Collar(H) is 3~4mm from Cutting Device Basement.
- ③ When Upper Cutting Knife(D) does not return after descending, loosen Screws(K) turn Return Spring Latch(M) to direction(N) little by little so that Upper Cutting Knife returns. At this time take care not to make the returning strength of Cutter(Upper) too much.

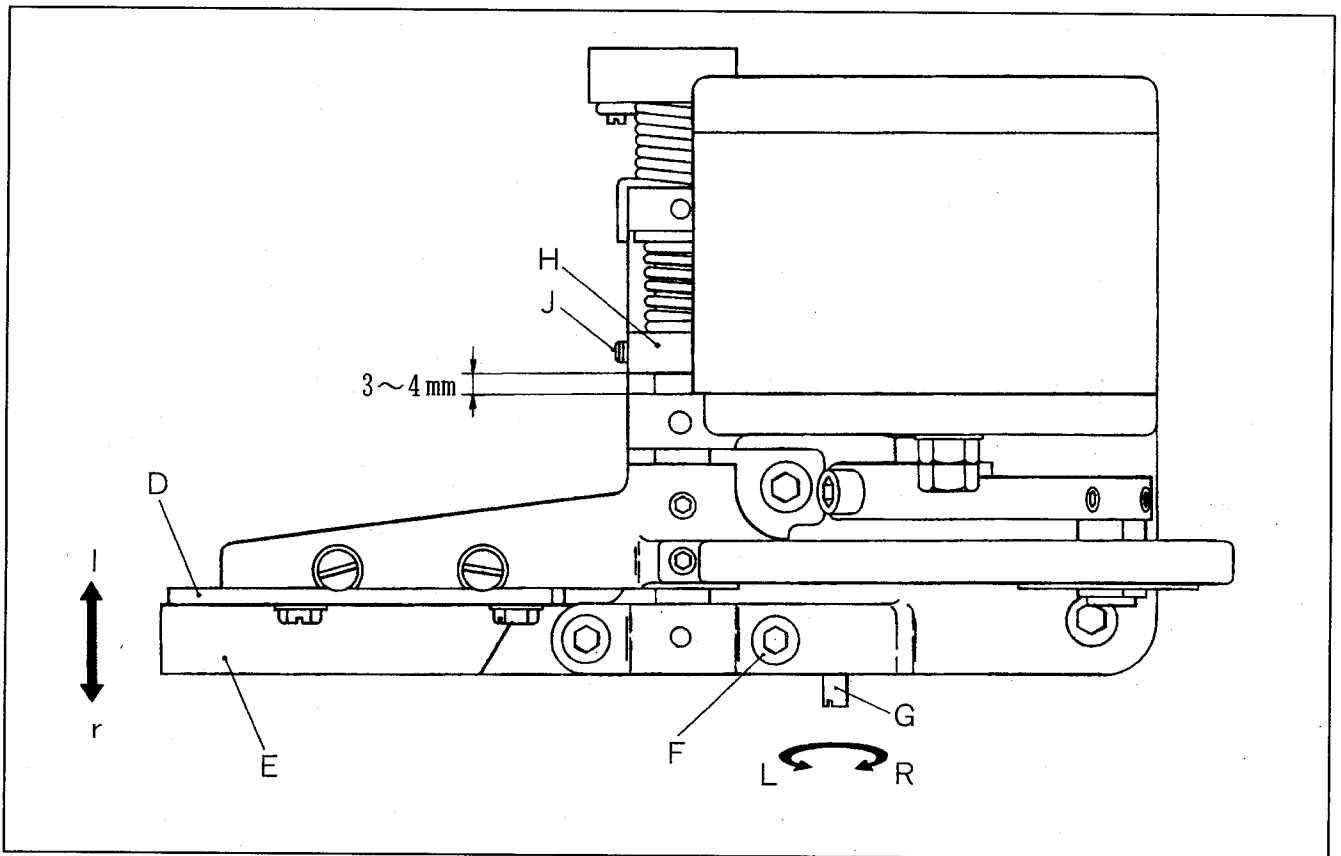

- * When the sharpness of Cutting Knives are not sufficient, check the following items:
- ☆ Is the engagement of Upper and Lower Cutting Knife proper?
 - ☆ Are Upper and/or Lower Cutting Knives worn out?
 - ☆ Does the blade of Upper Cutting Knife descend to be flush with undersurface of Lower Cutting Knife?
 - ☆ Is the pressure on Upper Cutting Knife proper?

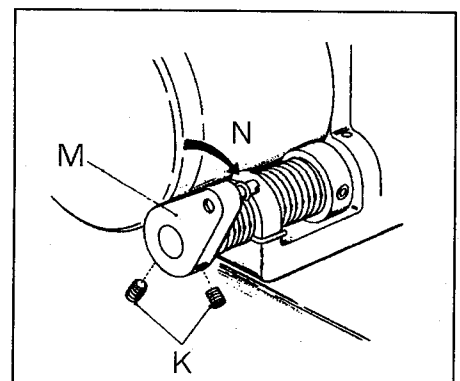

7. Adjustment of "AU20" Cutter Device

7-1 Adjustment of cutting angle of Knives

The cutting angle of Knife has been adjusted at $30' \sim 1^\circ$ at the time of shipment.

If the re-adjustment is necessary owing to the replacement of Knife, loosen Screws(A) and (B), remove Cutting Device and loosen Screws(C) and (D) of Lower Cutting Knife then adjust the angle at $30' \sim 1^\circ$.

When setting Cutting Device, to prevent Lower Cutting Knife from shifting, contact front face of Lower Cutting Knife to the side of Stitch Plate and fix it with Screws(A) and (B).

Note: Because the cutting angle is an important factor affecting the sharpness of Knives, adjust the angle correctly.

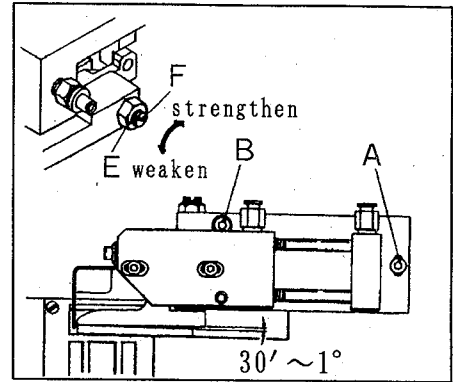

7-2 Adjustment of Upper Cutting Knife pressure

After loosening Lock Nut(E), turn Adjusting Screw (F) to the right to strengthen the pressure and to the left to weaken the pressure.

The pressure should be adjusted according to the firmness and the thickness of tape.

For the durability of cutter, the pressure should be as weak as possible so long as the tape can be cut satisfactory.

