

Yamato[®]

Parts List

4 NEEDLE FLATBED BOTH-CUT FLATSEAMER

VFK2560-8

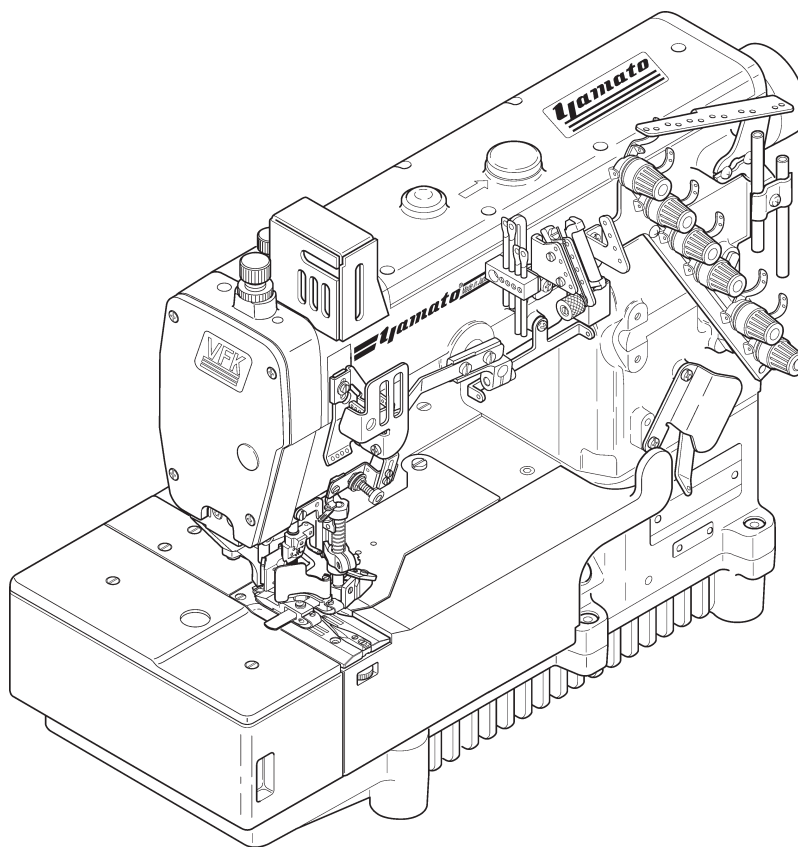

MODEL & DEVICE

VFK2560-02M-8

SC30 K1 FL

 **YAMATO SEWING MACHINE MFG. CO., LTD.**

パーツリストの見方

このパーツリストは VFK2560-152M-02M-8, 160M-02M-8を基本モデルにしてイラストを作成しています。
項目 1～ 15には基本モデルを記載しています。
項目 16～付帯装置等を記載しています。
パーツリストに記載されているカラーの寸法は内径 ×外径 ×幅を表わしています。

記号の説明(Parts No. の隣に記載されています。)

[] 前回のパーツリストに対して、今回変更された部品を表わしています。

[] 内は旧 Parts No. 及びネジ類の形状

◆ 前回のパーツリストに対して、今回追加された部品及びモデルを表わしています。

部品注文の際のご注意

☆ このパーツリストに記載されている部品をご注文の際は、Parts No.(例えば、3500201)をお願いします。

☆ 0068011の場合は、0068011又は 68011でご注文下さい。

☆ エアチューブ御注文の際は品番と長さをお知らせ下さい。

なお、このパーツリストの記載事項は、改良により変更される場合がありますのでご了承下さい。

How to use this Parts List

The illustrations on this Parts List are drawn on the basis of VFK2560-152M-02M-8, 160M-02M-8.

The items from No.1 to No.15 contain the standerd model.

The following items included No.16 contain the Device.

The dimension of Collar on this Parts List shows Inside diameter X Outside diameter X Width.

Explanation of Marks(marked at the Side of Part No.)

[] means this part is changed from the previous Parts List.

Inside of[] shows the previous Part No. and the shape of screw or the like.

◆ means this part and model is added to the previons Parts List.

How to place an order for the parts

☆ When placing an order for the parts from this Parts List, please clearly state the Parts No.(e.g.3500201) which you require so that we can deliver the correct Parts to you.

☆ When the Part No. is“0068011”,please place an order for the part by showing“0068011” or“68011” .

☆ When ordering Air Tube, please inform us of the Part No. and the length.

This Parts Listis subject to change without notice.

Contents

目次

MISCELLANEOUS COVERS(1)	カバー関係 (1)	1
MISCELLANEOUS COVERS(2)	カバー関係 (2)	2
MISCELLANEOUS THREAD EYELETS	糸道関係	3
MISCELLANEOUS BUSHINGS & HR DEVICE	プッシュ及びHR装置関係	4
MAIN SHAFT DRIVING MECHANISM	下軸機構	5
UPPER SHAFT & NEEDLE THREAD TAKE-UP MECHANISM	上軸及び針糸繰り機構	6
NEEDLE BAR MECHANISM	針棒機構	7
PRESSER FOOT MECHANISM	押工機構	8
MISCELLANEOUS PRESSER FOOT	押工関係	9
UPPER KNIFE DRIVING MECHANISM	上メス機構	10
SPREADER MECHANISM	飾り糸ルーパ機構	11
LOOPER DRIVING MECHANISM	ルーパ機構	12
FEED DRIVING CONTROL MECHANISM	前送り調節機構	13
FEED DRIVING MECHANISM	送り機構	14
LUBRICATING MECHANISM	給油機構	15
SC30 DEVICE	SC30装置	16
K1 DEVICE	K1装置	17
FL DEVICE	FL装置	18
SUPPORTING BOARD(1)	受け板 (1)	19
SUPPORTING BOARD(2)	受け板 (2)	20
THREAD STAND	糸立台	21
WARNING LABEL	警告ラベル	22
INDEX	索引	23

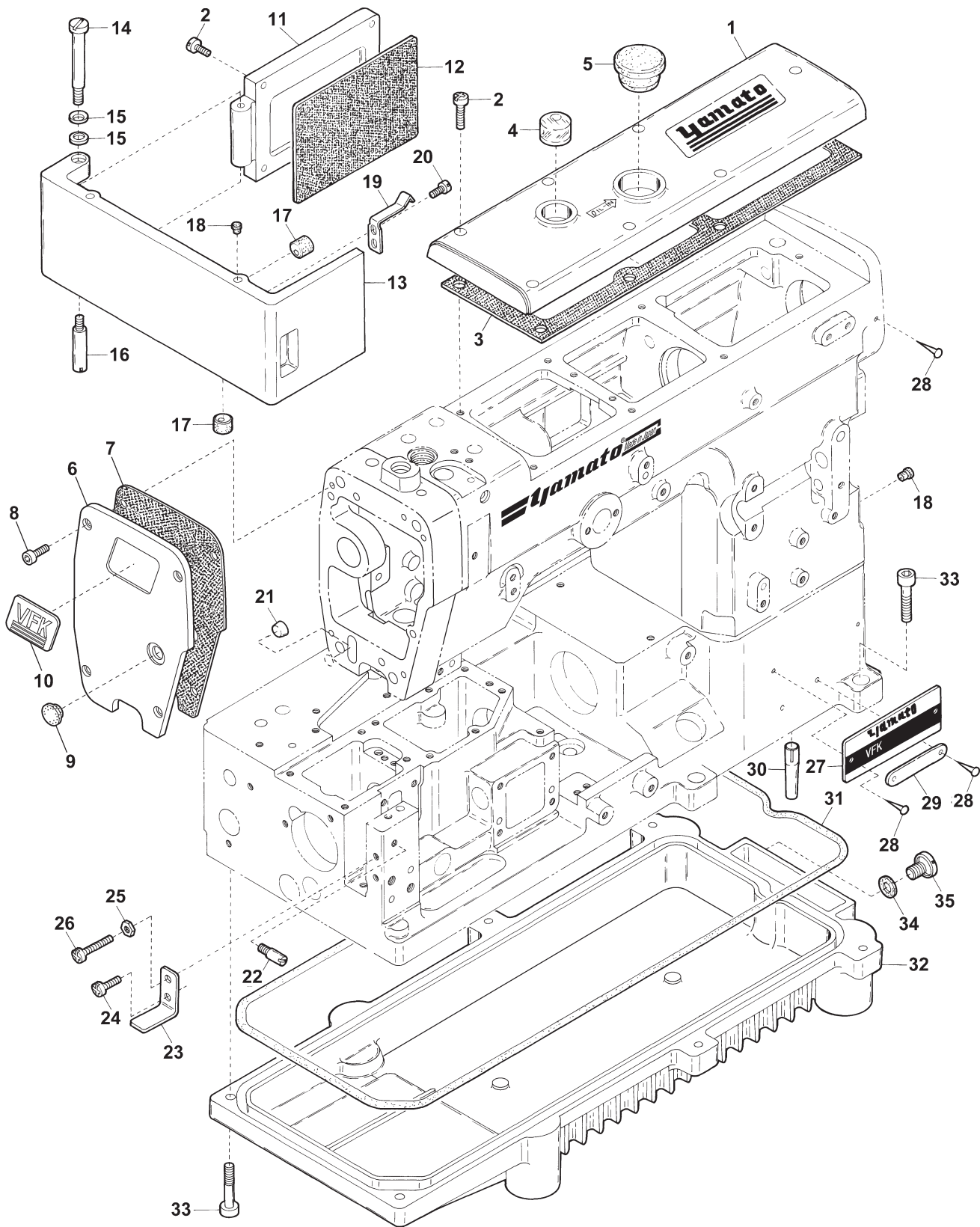

Ref.No.	Parts No.	Description	品名	Amt. Req
1	3210002	Top Cover	上カバー	1
2	110045	Screw(M4-0.7×12)	止ネジ	11
3	3500430	Top Cover Gasket	上カバーパッキン	1
4	0068011	Oil Sight Window	オイル確認窓	1
5	0020759	Top Cover Seal Plug	上カバー詰栓	1
6	3230020	Head Cover	ヘッドカバー	1
7	3230021	Head Cover Gasket	ヘッドカバーパッキン	1
8	009748	Screw(M4-0.7×12)	止ネジ	4
9	3500014	Head Cover Seal Plug	詰栓	1
10	390242	"VFK" Emblem	VFK エンブレム	1
11	3040039	Bed Rear Cover	ベッド後カバー	1
12	0095108	Bed Rear Cover Gasket	ベッド後カバーパッキン	1
13	3040038	Side Cover	横開キカバー	1
14	170001	Screw(M5-0.8×8)	止ネジ	1
15	300100	Conical Spring Washer	皿バネワッシャ	2
16	180005	Screw(M5-0.8×8)	止ネジ	1
17	0032604	Rubber Cushion(Large)	クッションゴム(大)	2
18	3200033	Rubber Cushion(Small)	クッションゴム(小)	3
19	3200012	Cover Latch Spring	カバーラッチバネ	1
20	110012	Screw(M4-0.7×5)	止ネジ	2
21	330000	Seal Plug	詰栓	1
22	180018	Screw(M4-0.7×7)	バネ掛ケネジ	1
23	3200013	Side Cover Holder	横開キカバー受ケ	1
24	110013	Screw(M4-0.7×8)	止ネジ	1
25	000015	Nut	ナット	1
26	110016	Screw(M4-0.7×15)	止ネジ	1
27	4109410	Model Plate(See the below)	型式板(下記参照)	1
28	000726	Rivet	止メ鋲	5
29	6209401	Serial Number Plate	機番プレート	1
30	340016	Machine Frame Supporting Bar	ベッド支工棒	4
31	3200007	Oil Reservoir Gasket	油受ケパッキン	1
32	3200245	Oil Reservoir	油受ケ	1
33	009970	Screw(M6-1×20)	止ネジ	6
34	0020137	Drain Hole Seal	油抜キネジパッキン	1
35	005075	Screw(3/8-24×8)	油抜キネジ	1

Note : Order for Model Plate must be accompanied by model designation(including symbols of gauge and devices).

(注) 型式板を御注文の際は機種名(ゲージ記号, 付帯装置含む)をお知らせ下さい。

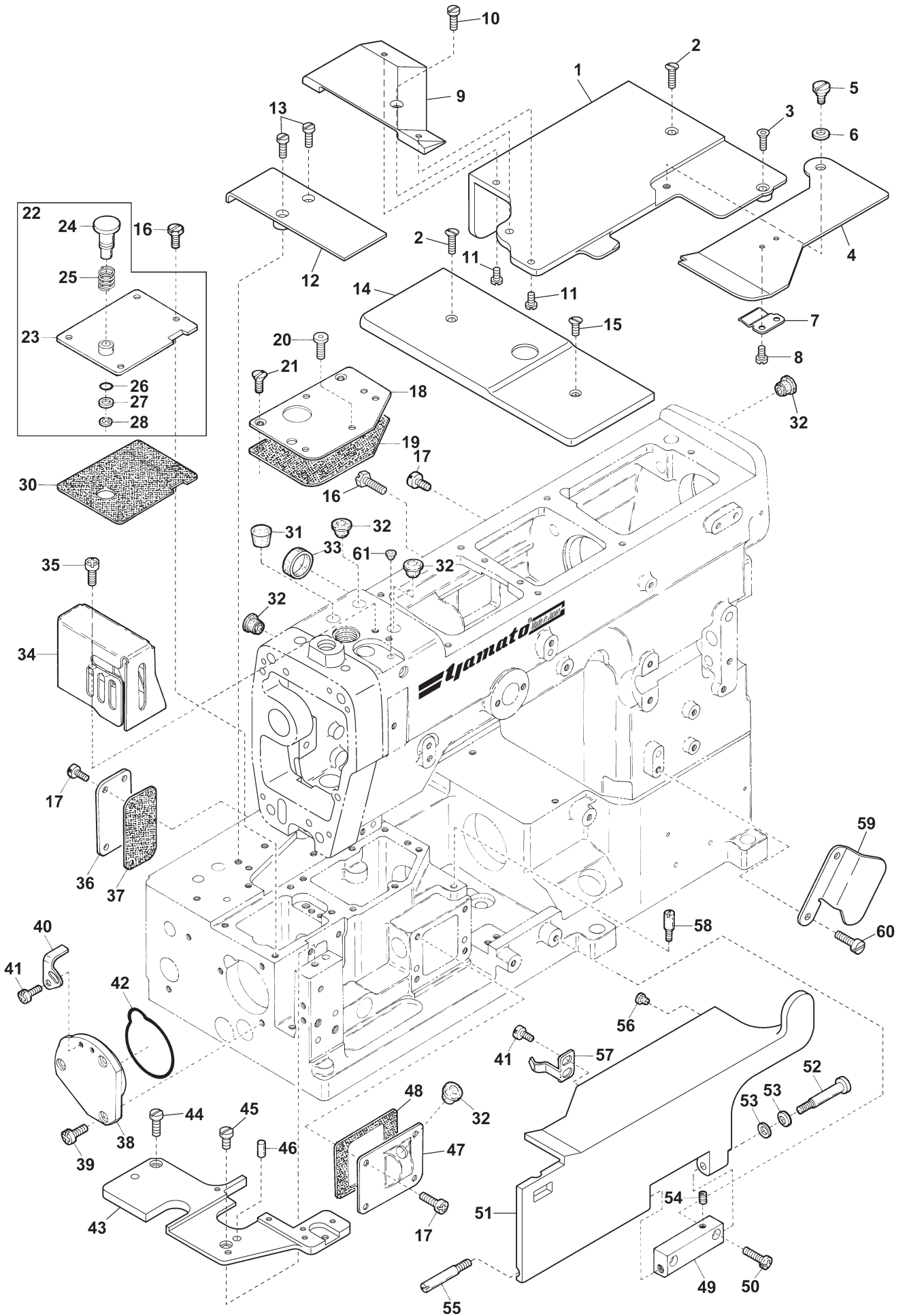

Ref.No.	Parts No.	Description	品 名	Amt. Req
1	3230023	Cloth Plate(Large)(Lower)	大カバー (下)	1
2	130004	Screw(M4-0.7×14)	止ネジ	2
3	009776	Screw(M4-0.7×10)	止ネジ	1
4	3230026	Looper Thread Take-up Cover(52, 60)	カムカバー	1
5	006004	Screw(11/64-40×9.7)	止ネジ	1
6	000010	Conical Spring Washer	皿バネワッシャ	1
7	3230027	Take-up Cover Spring	カムカバーバネ	1
8	110030	Screw(M3-0.5×2.6)	止ネジ	2
9	3230022	Cloth Plate(Large)(Upper)	大カバー (上)	1
10	110043	Screw(M4-0.7×14)	止ネジ	1
11	110036	Screw(M3-0.5×6.5)	止ネジ	2
12	3230030	Supplementary Cover	補助カバー	1
13	110035	Screw(M4-0.7×10)	止ネジ	2
14	3230025	Cloth Plate(Small)	小カバー	1
15	130021	Screw(M4-0.7×6)	止ネジ	1
16	007610	Screw(M4-0.7×10)	止ネジ	5
17	110013	Screw(M4-0.7×8)	止ネジ	9
18	3200024	Bed Top Cover(Right)	ベッド上カバー (右)	1
19	3200025	Bed Top Cover(Right) Gasket	ベッド上カバー (右) パッキン	1
20	120066	Screw(M4-0.7×10)	止ネジ	4
21	130006	Screw(M4-0.7×10)	止ネジ	2
22	3203000	Bed Top Cover(Left), C. Set	ベッド上カバー (左)(組)	1
23	3200022	Bed Top Cover(Left)	ベッド上カバー (左)	1
24	3200209	Feed Regulating Pushbutton	プッシュボタン	1
25	0063152	Feed Regulating Pushbutton Spring	プッシュボタンバネ	1
26	0020472	O-ring(P6)	Oリング	1
27	000425	Washer	ワッシャ	1
28	0033024	Retaining Ring	ストップリング	1
29				
30	3200023	Bed Top Cover(Left) Gasket	ベッド上カバー (左) パッキン	1
31	0065275	Seal Plug	詰栓	1
32	3500014	Seal Plug	詰栓	5
33	3100006	Seal Plug	詰栓	1
34	3100113	Needle Bar Cover	針棒カバー	1
35	110079	Screw(M4-0.7×8)	止ネジ	2
36	3200028	Bed Rear Cover(Small)	ベッド後カバー (小)	1
37	3200029	Bed Rear Cover(Small) Gasket	ベッド後カバー (小) パッキン	1
38	3200030	Ball Bearing Housing	ハウジング	1
39	110048	Screw(M4-0.7×10)	止ネジ	3
40	3200210	Pushbutton Stop	プッシュボタンストッパ	1

Ref. No. 41 to 61 See the following page.

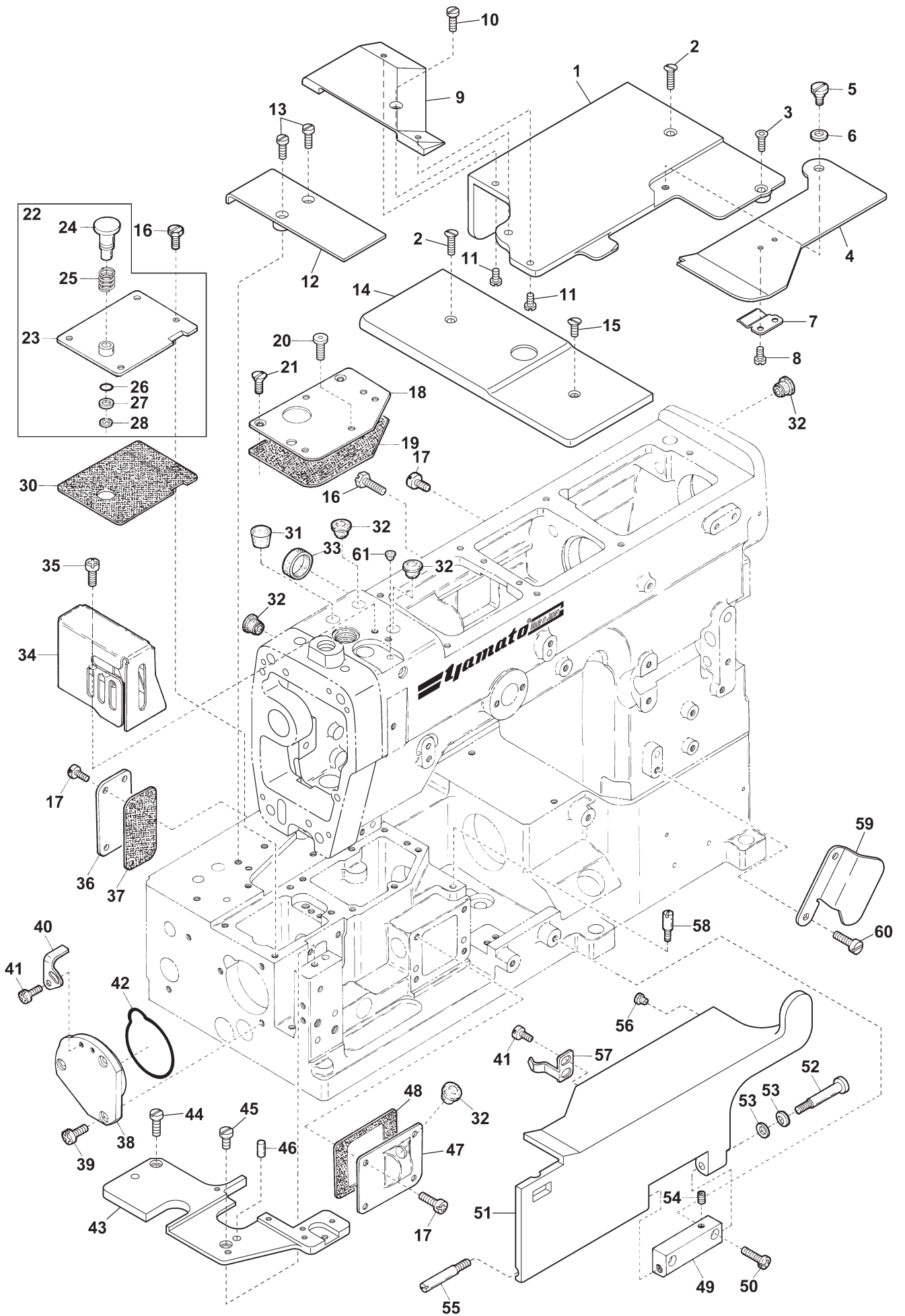

Ref.No.	Parts No.	Description	品 名	Amt. Req
41	110012	Screw(M4-0.7×5)	止ネジ	4
42	3200031	O-ring	Oリング	1
43	3231009 [3230031]	Stitch Plate Support	針板台	1
44	110041	Screw(M4-0.7×8)	止ネジ	1
45	110001	Screw(M4-0.7×5.4)	止ネジ	1
46	000745	Knock Pin	ノックピン	2
47	3200026	Bed Front Cover	ベッド前カバー	1
48	3200027	Bed Front Cover Gasket	ベッド前カバーパッキン	1
49	3040040	Front Cover Hinge	前開キカバーヒンジ	1
50	110016	Screw(M4-0.7×15)	止ネジ	2
51	3230028	Front Cover(52, 60)	前開キカバー	1
52	170020	Screw(M4-0.7×8)	止ネジ	1
53	300100	Conical Spring Washer	皿バネワッシャ	2
54	160001	Screw(M4-0.7×4)	止ネジ	1
55	180017	Screw(M4-0.7×6)	止ネジ	1
56	330011	Rubber Cushion(Small)	クッションゴム (小)	2
57	3200016	Front Cover Spring	前開キカバーバネ	1
58	180018	Screw(M4-0.7×7)	バネ掛ケネジ	1
59	3230074	Looper Thread Guard	ルーパ糸ガード	1
60	110009	Screw(M4-0.7×8)	止ネジ	2
61	330011 ◆	Rubber Cushion (Small)	クッションゴム (小)	1

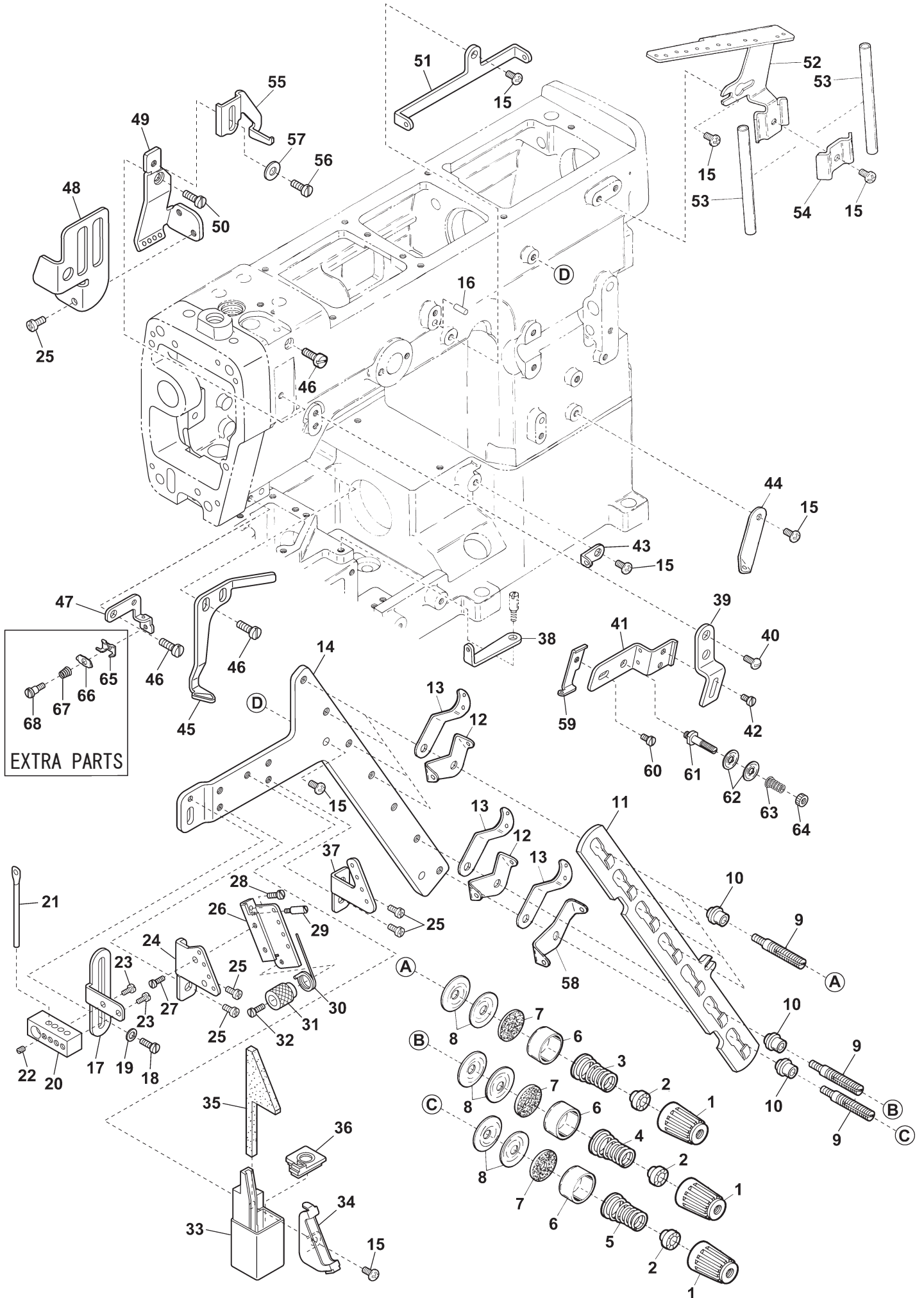

Ref.No.	Parts No.	Description	品名	Amt. Req
1	0024084	Thread Tension Spring Cap	糸調子バネキャップ(上)	6
2	0024083	Tension Spring Bushing	糸調子ナット回り止メ	6
3	0030255	Needle Thread Tension Spring	針糸調子バネ	4
4	0032952	Top Cover Thread Tension Spring	飾り糸調子バネ	1
5	0032952	Looper Thread Tension Spring	ルーパ糸調子バネ	1
6	0090071	Thread Tension Spring Retainer	糸調子バネキャップ(下)	6
7	000177	Felt	フェルト	6
8	0031111	Tension Disc	糸調子皿	12
9	290029	Tension Post	糸調子棒	6
10	0090812	Tension Post Ferrule	糸調子棒糸摺レ	6
11	3201162	Tension Disc Separator	糸緩メ板	1
12	0090856	Tension Disc Eyelet	糸調子皿糸道	5
13	0090807	Thread Lead-in Guide	糸調子台糸道	6
14	3230075	Tension Post Support	糸調子台	1
15	110013	Screw(M4-0.7×8)	止ネジ	9
16	000651	Guide Pin	ガイドピン	1
17	3230078	Needle Thread Eyelet Holder Plate	針糸道台取付板	1
18	110035	Screw(M4-0.7×10)	止ネジ	1
19	000538	Washer	ワッシャ	1
20	0068247	Needle Thread Eyelet Holder	針糸道台	1
21	0068249	Needle Thread Eyelet	針糸道	4
22	003312	Screw(1/8-44×3.4)	止ネジ	4
23	007616	Screw(1/8-44×4.2)	止ネジ	2
24	3230082	Needle Thread Eyelet(Left)	針糸道(左)	1
25	110012	Screw(M4-0.7×5)	止ネジ	6
26	0068250	Stitch Unlocking Mounting Bracket	針糸道バネブラケット	1
27	004245	Screw(11/128-56×3.2)	止ネジ	2
28	004134	Screw(1/8-44×6.5)	止ネジ	1
29	004191	Screw(11/128-56×2.5)	止ネジ	1
30	0068251	Stitch Unlocking Spring	針糸道バネ	1
31	0068252	Stitch Unlocking Spring Holder	針糸道バネホルダ	1
32	001196	Screw(1/8-44×6)	止ネジ	1
33	2150030	Oil Container	SP タンク	1
34	3230076	Felt Holder	SP フェルト押エ	1
35	310137	Felt	SP フェルト	1
36	2150031	Oil Container Plug	詰栓	1
37	3230077	Needle Thread Eyelet(Right)	針糸道(右)	1
38	2100065	Looper Thread Eyelet	ルーパ糸道	1
39	3230092	Top Cover Thread Eyelet Support	飾り糸道台	1
40	009784	Screw(M6-1×10)	止ネジ	2

Ref. No. 41 to 68 See the following page.

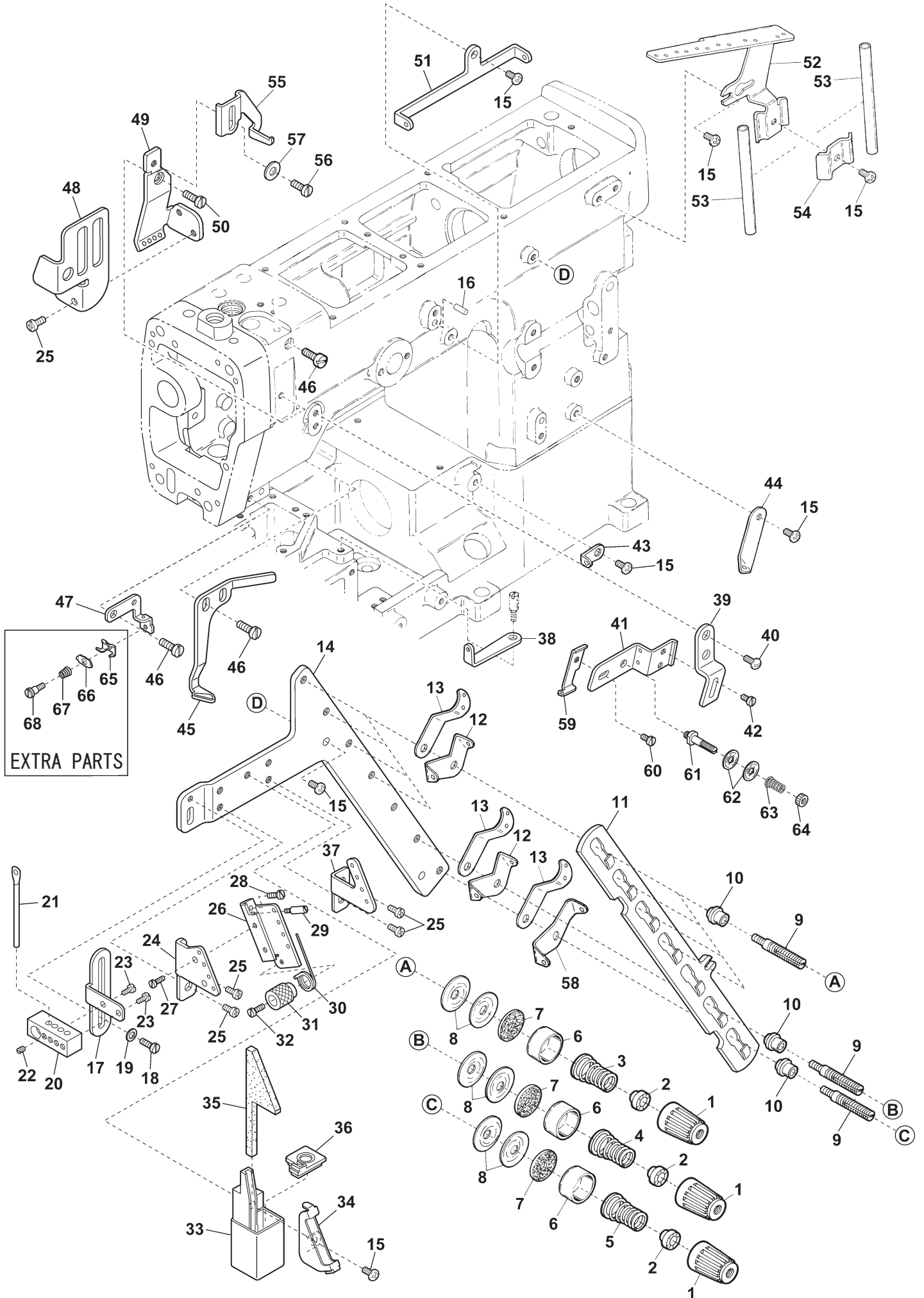

Ref.No.	Parts No.	Description	品名	Amt. Req
41	3230102 ◆	Top Cover Thread Eyelet Support	飾り糸道取付板	1
42	110054	Screw(M3-0.5×3.5)	止ネジ	2
43	3200042	Looper Thread Eyelet	ルーパ糸道	1
44	0093556	Looper Thread Eyelet(Long)	ルーパ糸道(長)	1
45	3230088	Top Cover Thread Guide	飾り糸案内	1
46	110009	Screw(M4-0.7×8)	止ネジ	3
47	3230104 [3230094]	Top Cover Thread Eyelet(Lower)	飾り糸道(下)	1
48	3230080	Needle Thread Take-up Guard	針糸繰りガード	1
49	3230085	Needle Thread Eyelet	針糸道	1
50	110001	Screw(M4-0.7×5.4)	止ネジ	1
51	3500489	Top Cover Thread Eyelet(Right)	飾り糸道(右)	1
52	3500284	Thread Guide Plate	糸案内板	1
53	0020119	Thread Eyelet Pipe(Short)	糸道パイプ(短)	2
54	3500285	Thread Eyelet Pipe Holder	糸道パイプ押エ	1
55	3230084	Needle Thread Guide	針糸受け	1
56	007627	Screw(M4-0.7×6)	止ネジ	1
57	000538	Washer	ワッシャ	1
58	0090857	Tension Disc Eyelet	糸調子皿糸道	1
59	3230103 [3230093]	Top Cover Thread Eyelet(Upper)	飾り糸道(上)	1
60	110054 ◆	Screw(M3-0.5×3.5)	止ネジ	1
61	001818 ◆	Tension Post	糸調子棒	1
62	0037108 ◆	Supplementary Tension Disc	小調子皿	2
63	0035813 ◆	Supplementary Tension Spring	飾り糸調子バネ	1
64	000360 ◆	Nut	ナット	1
65	3230106 ◆	Thread Retainer Disc Support	小調子板	1
66	2150107 ◆	Thread Retainer Disc	小調子皿	1
67	2150108 ◆	Thread Tension Spring	小調子バネ	1
68	170060 ◆	Screw(M2.5-0.45×4)	止ネジ	1

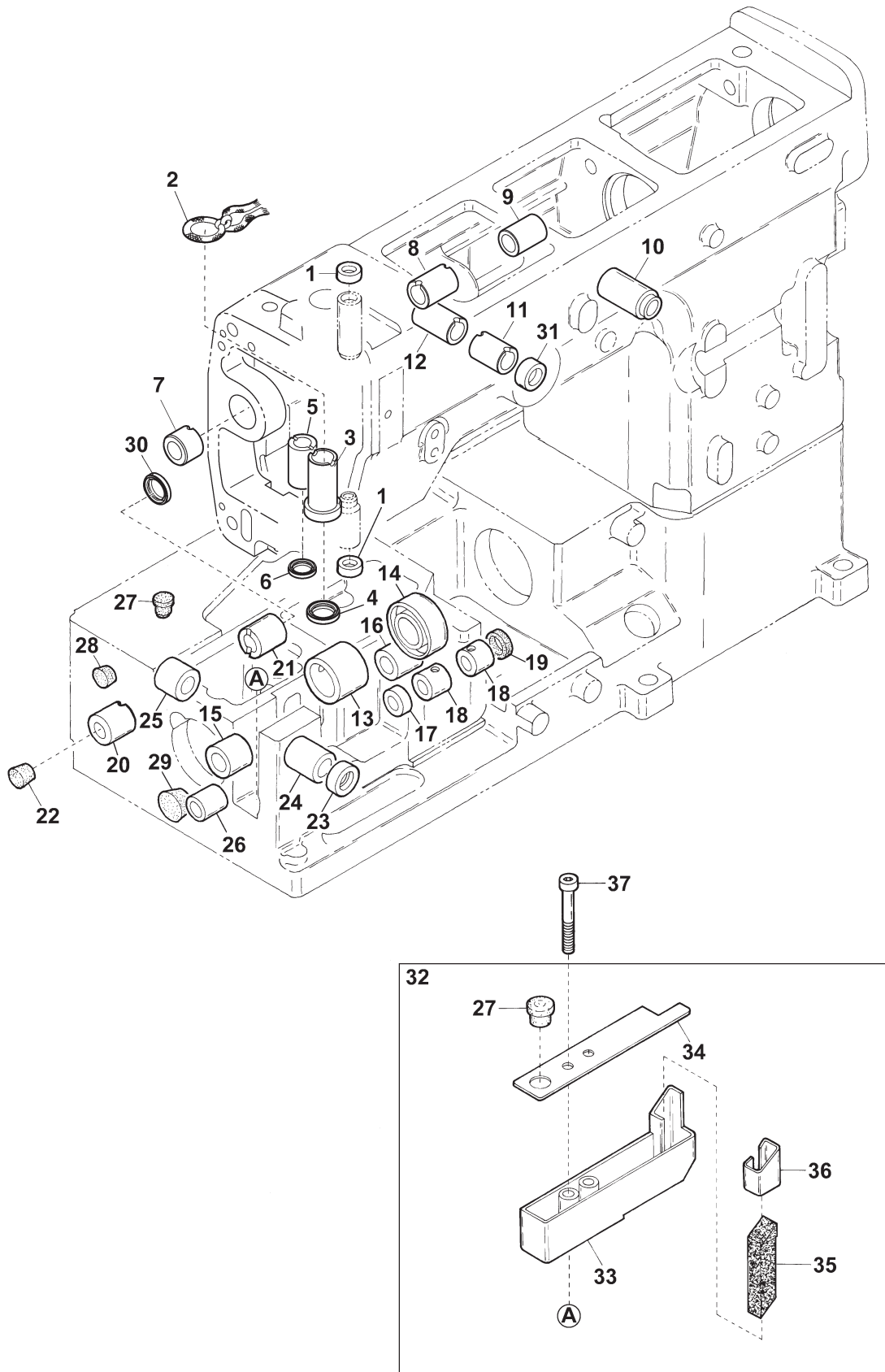

Ref.No.	Parts No.	Description	品名	Amt. Req
1	3204020	Oil Seal	オイルシール	2
2	000195	Oil Wick	油芯	1
3	3230011	Presser Bar Bushing	押工棒ブッシュ	1
4	3230014	Oil Seal	オイルシール	2
5	3230012	Spreader Driving Bar Bushing	飾り糸ルーパ棒ブッシュ	1
6	3230015	Oil Seal	オイルシール	1
7	3230013	Spreader Driving Shaft Bushing(Left)	飾り糸ルーパ軸ブッシュ(左)	1
8	3500047	Spreader Driving Shaft Bushing(Middle)	飾り糸ルーパ軸ブッシュ(中)	1
9	3500048	Spreader Driving Shaft Bushing(Right)	飾り糸ルーパ軸ブッシュ(右)	1
10	3160136	Foot Lifter Lever Bushing	押工揚ゲ軸ブッシュ	1
11	3500044	Needle Thread Take-up Bushing(Front)	針糸繰り軸ブッシュ(前)	1
12	3500045	Needle Thread Take-up Bushing(Rear)	針糸繰り軸ブッシュ(後)	1
13	3200050	Lower Shaft Bushing	下軸ブッシュ	1
14	3200067	Oil Seal	オイルシール	1
15	3200062	Looper Rocker Shaft Bushing(Left)	ルーパ前後軸ブッシュ(左)	1
16	3200052	Looper Rocker Shaft Bushing(Right)	ルーパ前後軸ブッシュ(右)	1
17	0077300	Oil Seal	オイルシール	1
18	3200056	Needle Guard Driving Shaft	針受ケ軸ブッシュ	2
19	3200057	Seal Plug	詰栓	1
20	3200053	Feed Bar Driving Shaft Bushing(Left)	送り軸ブッシュ(左)	1
21	3200065	Feed Bar Driving Shaft Bushing(Right)	送り軸ブッシュ(右)	1
22	2100034	Seal Plug	詰栓	1
23	0093303	Oil Seal	オイルシール	1
24	3200061	Looper Driving Shaft Bushing(Front)	ルーパ軸ブッシュ(前)	1
25	3200051	Looper Driving Shaft Bushing(Rear)	ルーパ軸ブッシュ(後)	1
26	3200055	Differential Lever Shaft Bushing	差動レバー軸ブッシュ	1
27	3500014	Seal Plug	詰栓	2
28	0065275	Seal Plug	詰栓	1
29	0095218	Seal Plug	詰栓	1
30	0093303 [3200066]	Oil Seal	オイルシール	1
31	3500050	Oil Seal	オイルシール	1
32	3200120	HR Device, C. Set	HR装置(組)	1
33	3200121	HR Cup	HRカップ	1
34	3200122	HR Cup Lid	HRカップ蓋	1
35	310036	HR Felt	HRフェルト	1
36	0093663	HR Felt Guard	フェルトガード	1
37	006219	Screw(M4-0.7×30)	止ネジ	2

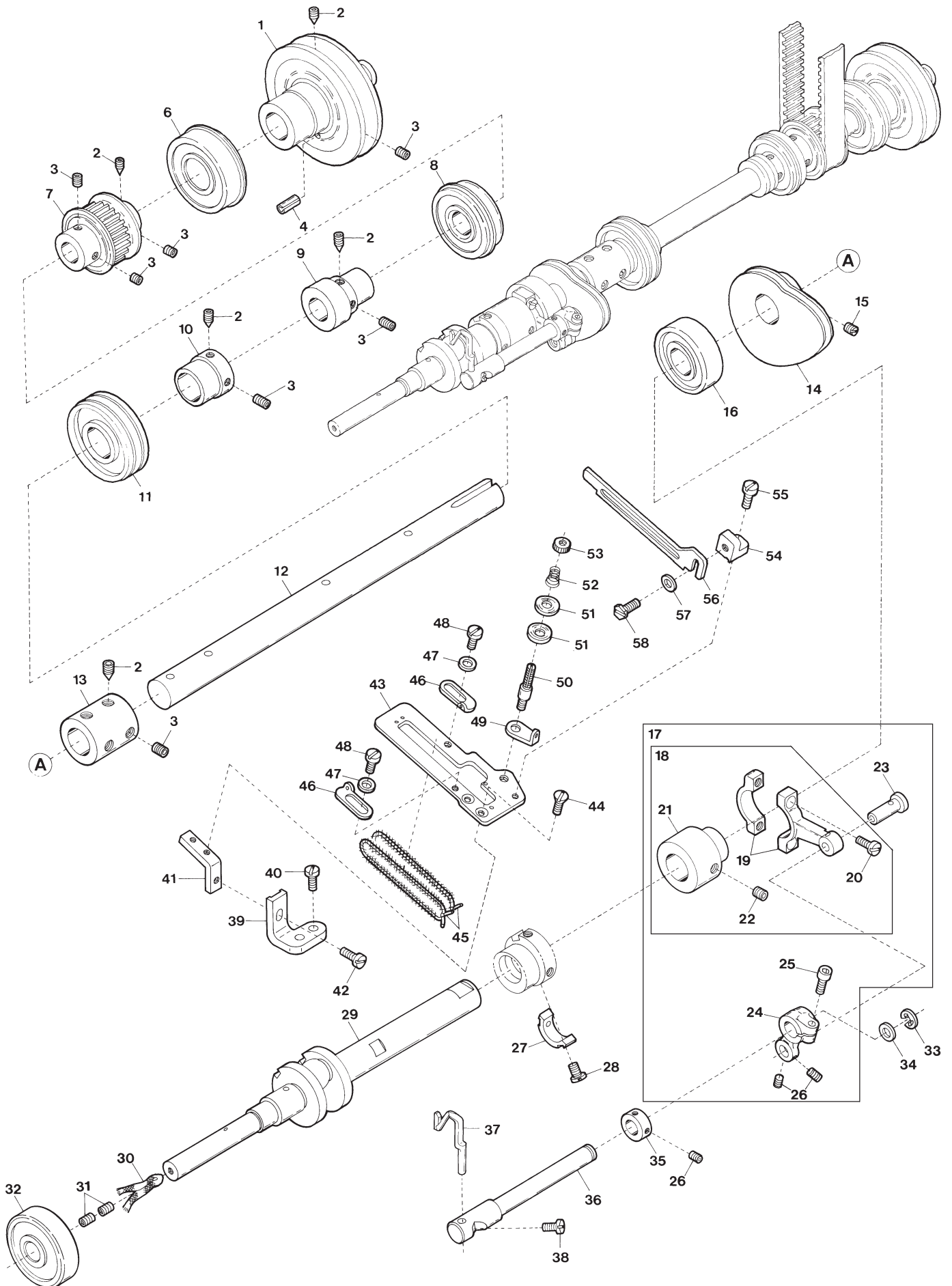

Ref.No.	Parts No.	Description	品名	Amt. Req
1	3200070	Pulley	プーリ	1
2	160005	Screw(M6-1 × 8)	止ネジ	5
3	160007	Screw(M6-1 × 6)	止ネジ	9
4	000037	Roll Pin	ロールピン	1
5				
6	3200095	Ball Bearing(Right)	ボールベアリング (右)	1
7	3100128	Timing Pulley(Lower)	タイミングプーリ (下)	1
8	3100131	Ball Bearing(Middle)	ボールベアリング (中)	1
9	3200072	Oil Pump Driving Worm	ウォーム	1
10	3100129	Adapter	アダプタ	1
11	3200078	Ball Bearing(Left)	ボールベアリング (左)	1
12	3200073	Lower Shaft(Right)	下軸 (右)	1
13	3200074	Lower Shaft Joint	継手	1
14	3200143	Looper Thread Take-up	下糸調子カム	1
15	150000	Screw(M5-0.8×4)	止ネジ	2
16	0093091	Ball Bearing	ボールベアリング	1
17	3200097	Needle Guard Connecting Rod, C. Set(2)	針受ケロッド (組 2)	1
18	3200096	Needle Guard Connecting Rod, C. Set(1)	針受ケロッド (組 1)	1
19	3200082	Needle Guard Connecting Rod	針受ケロッド	1
20	110005	Screw(M3.5-0.6×12)	止ネジ	2
21	3200098	Needle Guard Eccentric	針受ケエキセン	1
22	160003	Screw(M5-0.8×5)	止ネジ	2
23	3200087	Connecting Rod Pin	ロッドピン	1
24	3200084	Needle Guard Driving Shaft Arm	針受ケ軸腕	1
25	005650	Screw(M5-0.8×14)	止ネジ	1
26	160000	Screw(M3-0.5×3)	止ネジ	4
27	3200077	Counterweight	バランスウエイト	1
28	110036	Screw(M3-0.5×6.5)	止ネジ	2
29	3230120 [3230095]	Lower Crankshaft	下軸クランク	1
30	310035	Oil Wick	油芯	1
31	160001	Screw(M4-0.7×4)	詰ネジ	2
32	0020159	Ball Bearing	ボールベアリング	1
33	0068202	Retaining Ring	ストップリング	1
34	3200085	Spacer	スペーサ	1
35	3200086	Collar(8 × 13×6 mm)	カラー	1
36	3200083	Needle Guard Driving Shaft	針受ケ軸	1
37	3239200	Needle Guard(Rear) (52, 60)	針受ケ (後)	1
38	110083	Screw(M3.5-0.6×4.5)	止ネジ	1
39	3200093	Supporting Plate Stay(Lower)	カム糸道取付板支エ (下)	1
40	110048	Screw(M4-0.7×10)	止ネジ	2

Ref. No. 41 to 58 See the following Page.

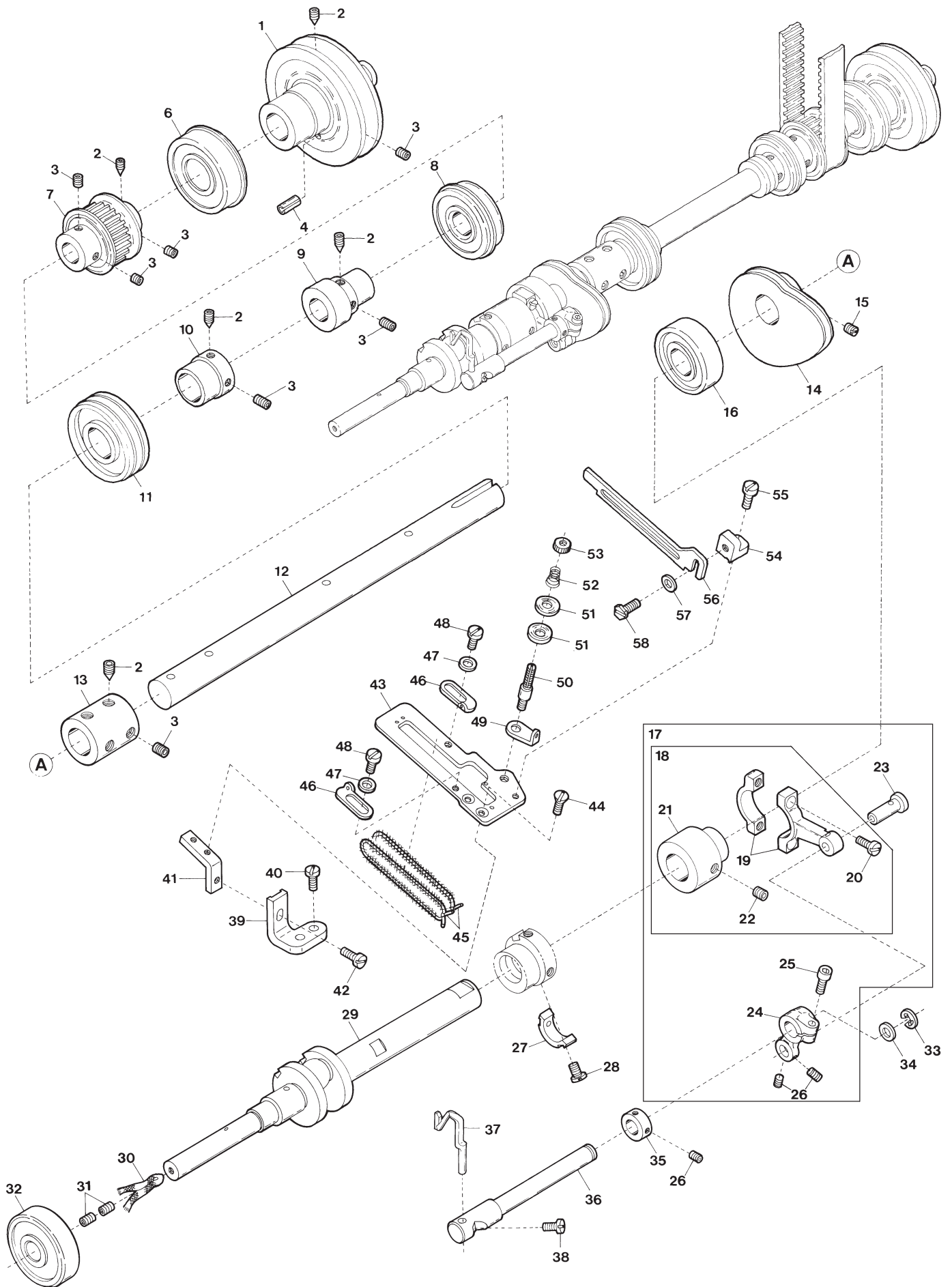

Ref.No.	Parts No.	Description	品 名	Amt. Req
41	3200092	Supporting Plate Stay(Upper)	カム糸道取付板支工 (上)	1
42	110009	Screw(M4-0.7×8)	止ネジ	1
43	3200091	Supporting Plate	カム糸道取付板	1
44	130002	Screw(M3-0.5×6)	止ネジ	2
45	000463	Laced Wire	モール (糸巻キ付防止)	2
46	0093515	Thread Take-up Eyelet	カム糸道	2
47	000014	Washer	ワッシャ	2
48	001227	Screw(1/8-44×3.8)	止ネジ	2
49	3200042	Looper Thread Eyelet	ルーパ糸道	1
50	001818	Tension Post	糸調子棒	1
51	0037108	Supplementary Tension Disc	小調子皿	2
52	0035813	Supplementary Tension Spring	小調子バネ	1
53	000360	Adjusting Nut	調節ナット	1
54	0063197	Cast-off Plate Bracket	糸案内台	1
55	001223	Screw(9/64-40×7.5)	止ネジ	1
56	3200094	Cast-off Plate	糸案内	1
57	000532	Washer	ワッシャ	1
58	004106	Screw(9/64-40×6.5)	止ネジ	1

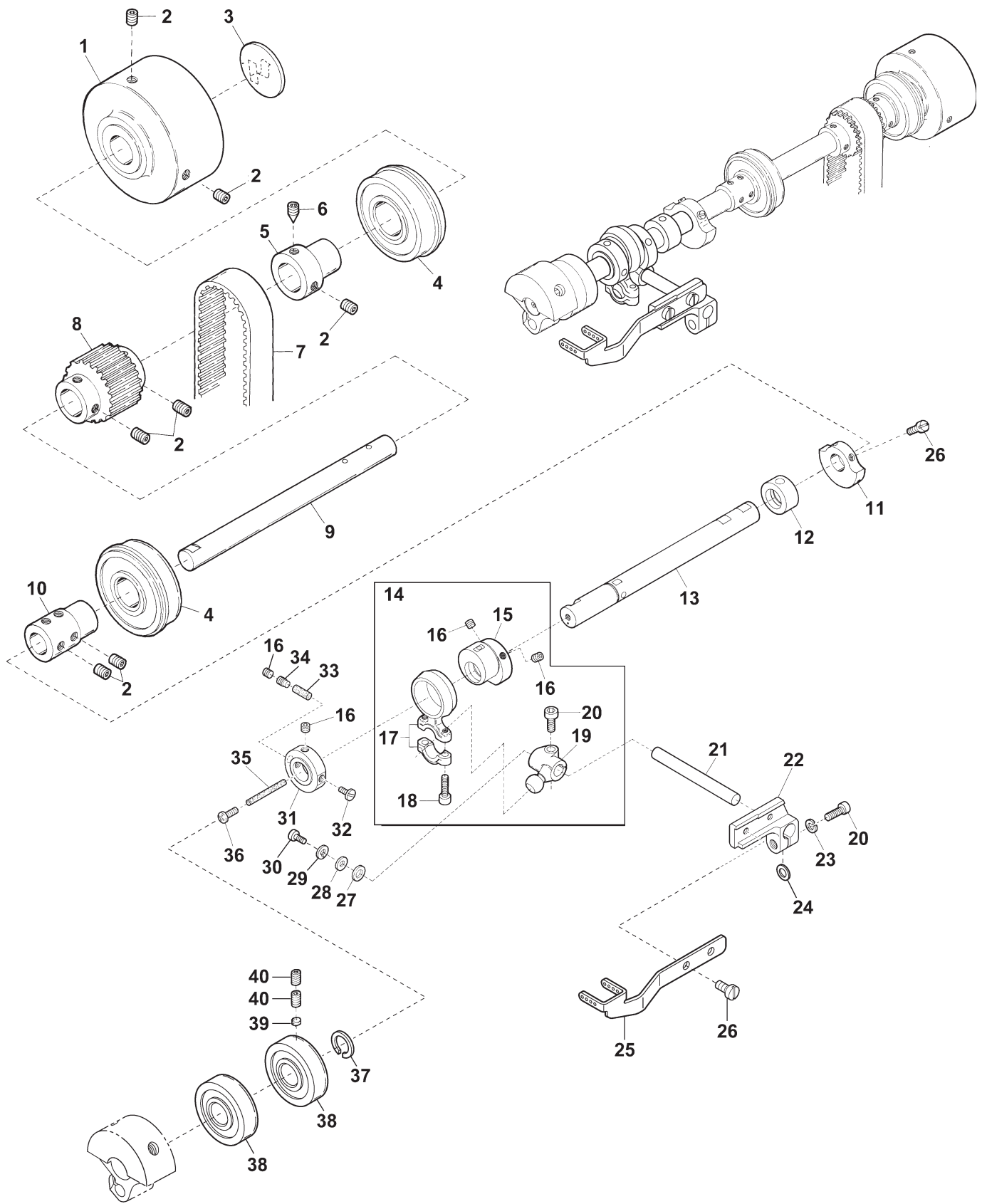

Ref.No.	Parts No.	Description	品 名	Amt. Req
1	3204066	Handwheel	ハンドホイール	1
2	160007	Screw(M6-1 × 6)	止ネジ	11
3	000989	Handwheel Mark	ハンドホイールマーク	1
4	3100131	Ball Bearing	ボールベアリング	2
5	3100129	Handwheel Adapter	アダプタ	1
6	160005	Screw(M6-1 × 8)	止ネジ	1
7	0095214	Timing Belt	タイミングベルト	1
8	3100281	Timing Pulley(Upper)	タイミングプーリ(上)	1
9	3100275	Upper Shaft(Right)	上軸(右)	1
10	3100283	Upper Shaft Joint	上軸継手	1
11	3100127	Counterweight(Small)	バランスウエイト(小)	1
12	3500448	Oil Sleeve	オイルスリーブ	1
13	3201533	Upper Shaft(Left)	上軸(左)	1
14	3230099	Connecting Rod, C. Set	針糸繰りロッド(組)	1
15	3230098	Needle Thread Take-up Eccentric	針糸繰リエキセン	1
16	160003	Screw(M5-0.8×5)	止ネジ	4
17	3500446	Connecting Rod	針糸繰りロッド	1
18	120001	Screw(M4-0.7×14)	止ネジ	2
19	3500066	Driving Lever	針糸繰り軸腕	1
20	120013	Screw(M6-1×15)	止ネジ	2
21	3500065	Driving Shaft	針糸繰り軸	1
22	3500492	Bracket	針糸繰り台	1
23	000667	Spring Washer	スプリングワッシャ	1
24	300067	Spacer	スペーサ	1
25	3230079	Needle Thread Take-up	針糸繰り糸道	1
26	110009	Screw(M4-0.7×8)	止ネジ	4
27	2100218	Spacer	スペーサ	1
28	000555	Washer	ワッシャ	1
29	000600	Spring Washer	スプリングワッシャ	1
30	120015	Screw(M5-0.8×10)	止ネジ	1
31	3500442	Collar	カラー	1
32	110135	Screw(M5-0.8×7)	止ネジ	1
33	310132	Oil Wick(Φ4.2×16mm)	油芯	1
34	160041	Screw(M5-0.8×8)	止ネジ	1
35	310099	Oil Wick	油芯	1
36	110012	Screw(M4-0.7×5)	止ネジ	1
37	0060057	Retaining Ring	止メ輪	1
38	0093154	Ball Bearing	ボールベアリング	2
39	000926	Rubber Seat	ゴム座	1
40	160004	Screw(M6-1×4.8)	止ネジ	2

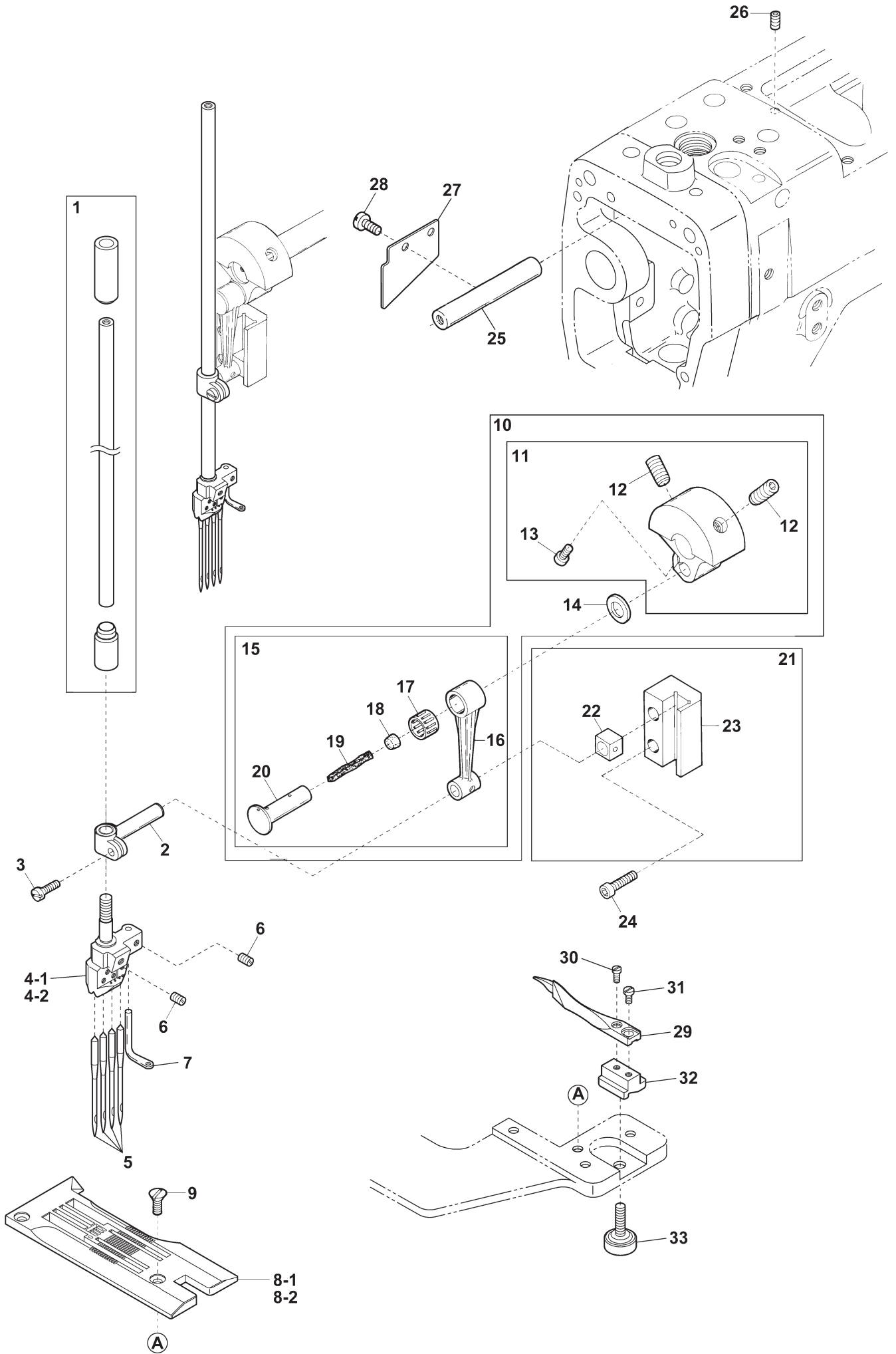

Ref.No.	Parts No.	Description	品名	Amt. Req
1	3204070	Needle Bar & Needle Bar Bushing, C. Set	針棒・針棒ブッシュ (組)	1
2	3500100	Needle Bar Bracket	針棒抱キ	1
3	110035	Screw(M4-0.7×10)	止ネジ	1
4-1	3239100	Needle Clamp(52)	針止メ	1
4-2	3239101	Needle Clamp(60)	針止メ	1
5	-----	Needle(MY-1014H)	針	4
6	150010 [160033]	Screw(M2.5-0.45×3)[M2.5-0.45×3]	止ネジ	5
7	0093365 [3200046]	Top Cover Thread Eyelet	飾り糸道	1
8-1	3238000	Stitch Plate(52M)	針板	1
8-2	3238001	Stitch Plate(60M)	針板	1
9	009142	Screw(9/64-40×4.8)	止ネジ	2
10	3200115	Counterweight, C. Set	バランスウエイト (組)	1
11	3200101	Counterweight	バランスウエイト	1
12	260000	Screw(5/16-24×15.88)	止ネジ	2
13	120015	Screw(M5-0.8×10)	止ネジ	1
14	0093214	Connecting Rod Ring	針棒ロッドリング	1
15	3200114	Connecting Rod, C. Set	針棒ロッド (組)	1
16	3200112	Connecting Rod	針棒ロッド	1
17	0093212	Roller Bearing	ニードルベアリング	1
18	330000	Seal Plug	詰栓	1
19	000309	Oil Wick	油芯	1
20	3200113	Connecting Rod Pin	針棒ロッドピン	1
21	3200118	Needle Bar Guide, C. Set	針棒案内 (組)	1
22	0093186	Slide Block	針棒案内駒	1
23	3200116	Needle Bar Guide	針棒案内	1
24	009749	Screw(M4-0.7×16)	止ネジ	2
25	3200090	Connecting Rod Cover Shaft	カバー軸	1
26	160023	Screw(M4-0.7×4)	止ネジ	1
27	3230038	Lubricant Guiding Plate	給油板	1
28	110002	Screw(M3-0.5×5)	止ネジ	2
29	3230090	Lap Former	ラップフォーマ	1
30	004172	Screw(3/32-56×3.4)	止ネジ	1
31	001228	Screw(3/32-56×3.2)	止ネジ	1
32	3230032	Lap Former Slide Block	ラップフォーマ台	1
33	190105	Knob(M4-0.7×14)	ツマミネジ	1

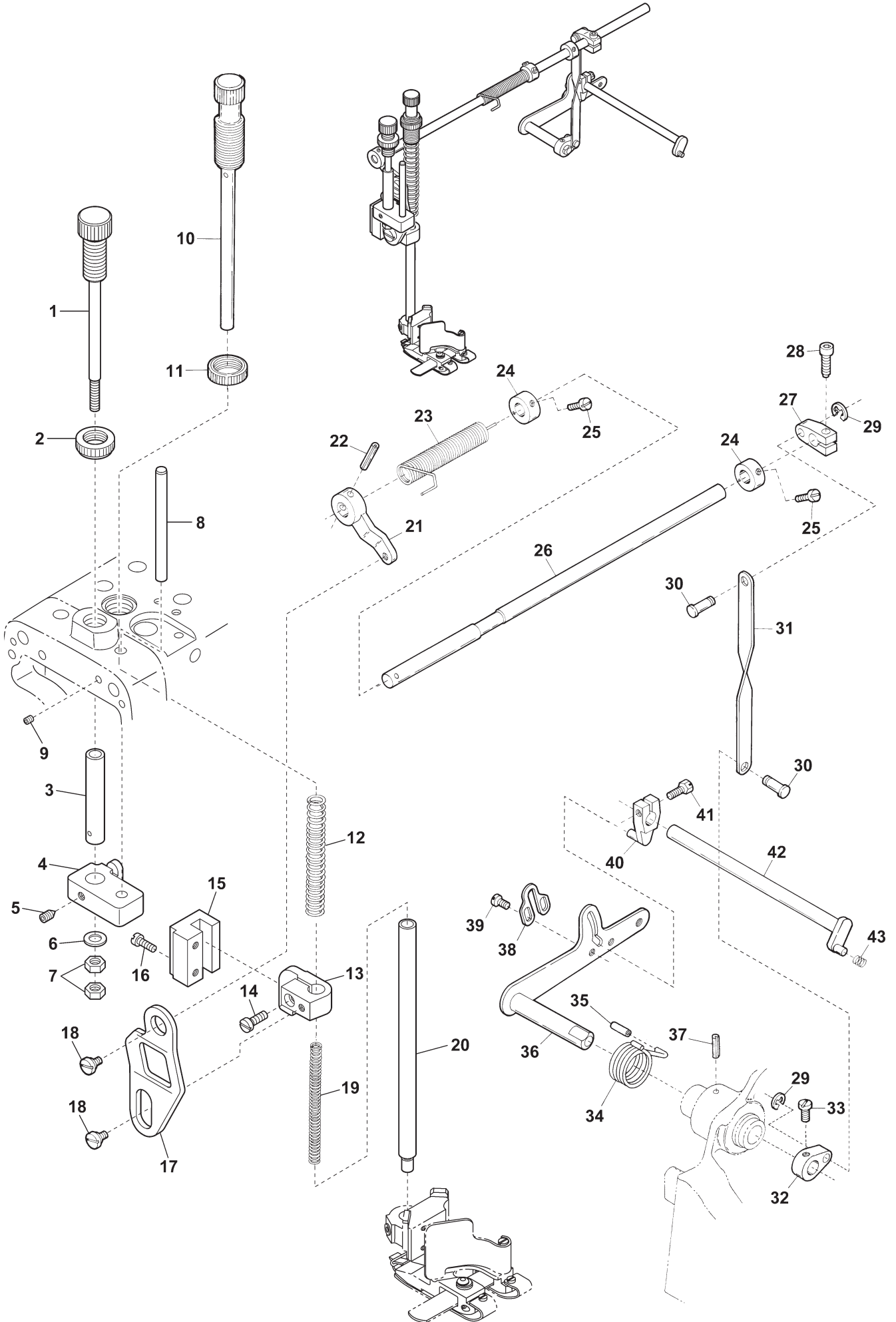

Ref.No.	Parts No.	Description	品 名	Amt. Req
1	3230072	Presser Foot Height Adjuster	押工高サ調節ネジ	1
2	100030	Lock Nut	ロックナット	1
3	3230066	Adjuster Guide	調節ネジガイド	1
4	3230067	Adjusting Block	調節ブロック	1
5	160021	Screw(M6-1 × 12)	止ネジ	1
6	000555	Washer	ワッシャ	1
7	100014	Nut	ナット	2
8	3230071	Adjusting Block Guide Bar	調節ブロックガイド棒	1
9	009736	Screw(M4-0.7×6)	止ネジ	1
10	0093500	Presser Spring Regulator	押工調節ネジ	1
11	000445	Lock Nut	ロックナット	1
12	3230065	Presser Bar Spring(Outer)	押工棒バネ(太)	1
13	3230061	Presser Bar Connecting Bracket Unit	押工棒抱キ(組)	1
14	110031	Screw(M4-0.7×12)	止ネジ	1
15	3230063	Presser Bar Guide	押工棒案内	1
16	004441	Screw(11/64-40×16)	止ネジ	2
17	3230060	Lifter Link	吊リリンク	1
18	006038	Screw(3/16-32×2.2)	止ネジ	2
19	3200137	Presser Bar Spring(Inner)	押工棒バネ(細)	1
20	3230064	Presser Bar	押工棒	1
21	0063083	Lifter Link Lever	吊リリンクレバー	1
22	000690	Fastener Pin	止メピン	1
23	0063084	Lifter Spring	押工揚ゲバネ	1
24	0093491	Collar(8 × 16×8 mm)	カラー	2
25	009604	Screw(11/64-40×5.5)	止ネジ	4
26	0093479	Lifter Shaft	押工揚ゲ軸	1
27	3100294	Intermediate Lever	押工揚ゲ中レバー	1
28	120017	Screw(M5-0.8×15)	止ネジ	1
29	0077179	Retaining Ring	止メ輪	2
30	0093509	Connecting Pin	連結ピン	2
31	0093507	Connecting Plate	連結桿	1
32	0093508	Lifter Lever(Small)	押工揚ゲレバー(小)	1
33	004591	Screw(15/64-28×9.5)	止ネジ	1
34	3160168	Lifter Spring	押工揚ゲバネ	1
35	3500305	Cap	キャップ	1
36	0093496	Lifter Lever	押工揚ゲレバー	1
37	340014	Roll Pin(3×12mm)	ロールピン	1
38	3101216	Lifter Lever Stop	押工揚ゲレバーストップ	1
39	004358	Screw(9/64-40×5.6)	止ネジ	2
40	0090801	Tension Release Lever	糸緩メ腕	1
41	005542	Screw(11/64-40×14.5)	止ネジ	1
42	0093545	Tension Release Shaft	糸緩メ軸	1
43	0090824	Swing-proof Spring	防振バネ	1

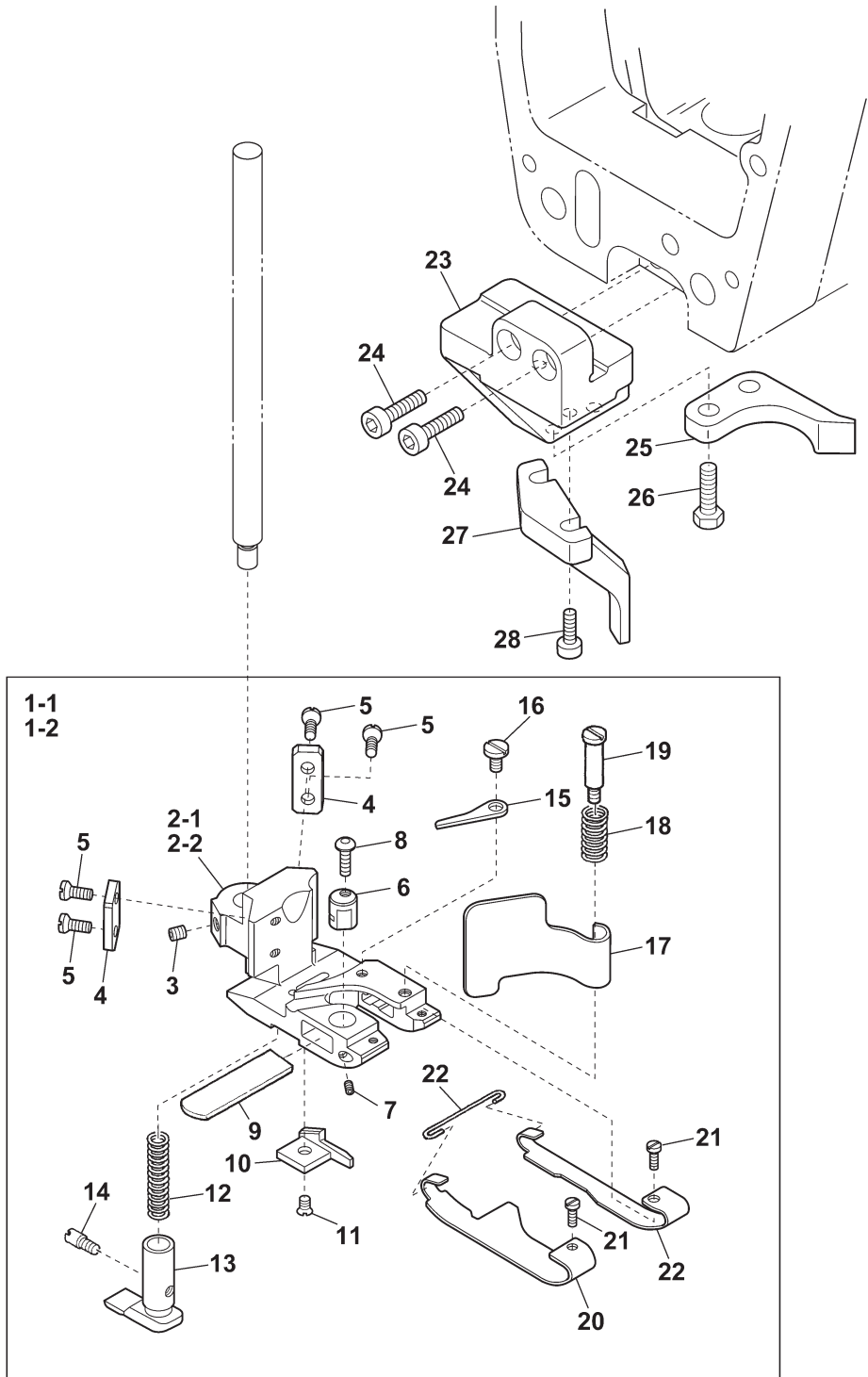

Ref.No.	Parts No.	Description	品 名	Amt. Req
1-1	3237000	Presser Foot, C. Set(52)	押工 (組)	1
1-2	3237001	Presser Foot, C. Set(60)	押工 (組)	1
2-1	3237005	Presser Foot(52)	押工	1
2-2	3237006	Presser Foot(60)	押工	1
3	160009	Screw(M5-0.8×5)	止ネジ	1
4	3237053	Presser Foot Attach Piece	押工ガイド板	2
5	130016	Screw(M2.5-0.45×5)	止ネジ	4
6	3237054	Lower Knife Pressure	下メス押工	1
7	160000	Screw(M3-0.5×3)	止ネジ	1
8	190101	Screw(M3-0.5×5)	止ネジ	1
9	0068121	Lower Knife	下メス	1
10	3237040	Cloth Guide Plate	布ガイド	1
11	004182	Screw(3/32-56×2.5)	止ネジ	1
12	0068117	Yielding Section Spring	小押工バネ	1
13	3027310	Yielding Section	小押工	1
14	004180	Screw(1/8-44×4.8)	止ネジ	1
15	3237052	Chip Guard Stopper	チップガードストッパ	1
16	110030	Screw(M3-0.5×2.6)	止ネジ	1
17	3237051	Chip Guard	チップガード	1
18	3027087	Chip Guard Spring	チップガードバネ	1
19	004166	Screw(1/8-44×3.2)	止ネジ	1
20	3237010	Presser Foot Spring Plate(Left)	押工板バネ (左)	1
21	004173	Screw(3/32-56×2.4)	止ネジ	2
22	3237011	Presser Foot Spring Plate(Reft)	押工板バネ (右)	1
23	3230068	Presser Foot Guide Holder	押工ガイド台	1
24	120015	Screw(M5-0.8×10)	止ネジ	2
25	3230070	Presser Foot Guide(Right)	押工ガイド (右)	1
26	006215	Screw(M4-0.7×10)	止ネジ	2
27	3230069	Presser Foot Guide(Left)	押工ガイド (左)	1
28	120008	Screw(M4-0.7×8)	止ネジ	2
29	3027238	Spring Plate Holder	押工板バネホルダ	1

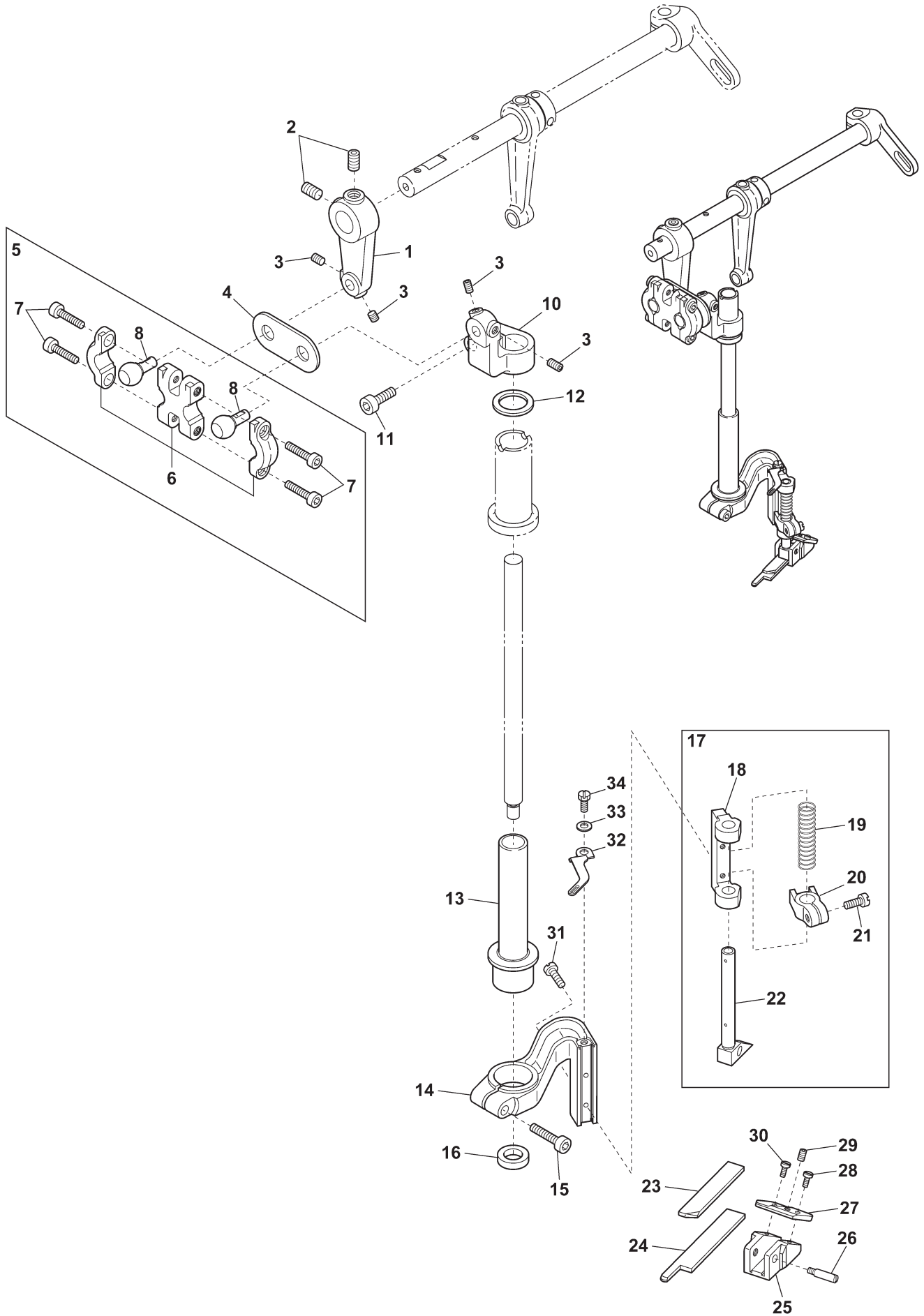

Ref.No.	Parts No.	Description	品名	Amt. Req
1	3230039	Knife Driving Arm	上メス腕	1
2	160007	Screw(M6-1 × 6)	止ネジ	2
3	009736	Screw(M4-0.7×6)	止ネジ	4
4	3230042	Oil Felt	給油フェルト	1
5	3230040	Knife Driving Connection , C. Set	上メスロッド (組)	1
6	3230041	Knife Driving Connection	上メスロッド	1
7	120053	Screw(M3.5-0.6×14)	止ネジ	4
8	3230046	Knife Driving Connection Ball	上メスロッド球	2
9				
10	3230043	Knife Lever	上メスレバー	1
11	005650	Screw(M5-0.8×14)	止ネジ	1
12	3230047	Thrust Ring	スラストリング	1
13	3230044	Knife Sleeve	上メススリーブ	1
14	3230101 [3230045]	Knife Holder Bracket	上メスホルダブラケット	1
15	120011	Screw(M6-1×18)	止ネジ	1
16	3204021	Oil Seal	オイルシール	1
17	3230108 [3230050]	Knife Holder Guide Collar, C. Set	上メスホルダガイドカラー (組)	1
18	3230109 [0068348]	Knife Holder Shank Support	上メスホルダシャック台	1
19	0068181	Knife Holder Spring	上メスホルダバネ	1
20	0068182	Knife Holder Guide Collar	上メスホルダガイドカラー	1
21	004185	Screw(9/64-40×7.2)	止ネジ	1
22	3230051	Knife Holder Shank	上メスホルダシャック	1
23	3230054	Knife Support	上メスサポート	1
24	0068184	Upper Knife	上メス	1
25	3230052	Knife Holder	上メスホルダ	1
26	180041	Screw(M3-0.5×3)	止ネジ	1
27	3230053	Knife Holder Support	上メスホルダ補助板	1
28	110007	Screw(M2.5-0.45×6)	止ネジ	1
29	160001	Screw(M4-0.7×4)	止ネジ	1
30	110038	Screw(M2.5-0.45×4.5)	止ネジ	1
31	001175	Screw(9/64-40×8)	止ネジ	2
32	3230105 ◆	Top Cover Thread Take-up	飾り糸繰り	1
33	000014 ◆	Washer	ワッシャ	1
34	140010 ◆	Screw(M4-0.7×8)	止ネジ	1

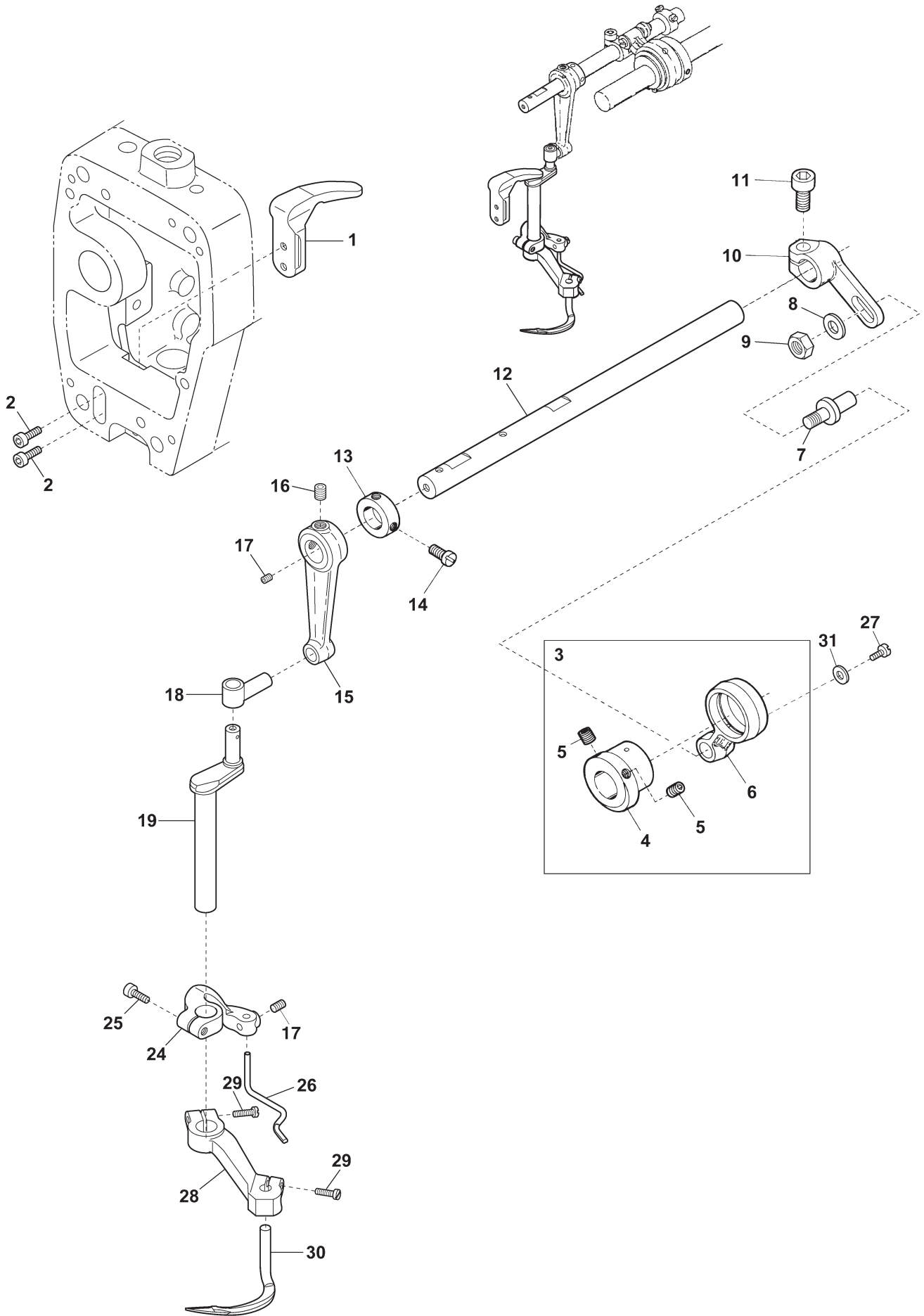

Ref.No.	Parts No.	Description	品名	Amt. Req
1	3230037	Spreader Bar Guide	ルーパ棒ガイド	1
2	120018	Screw(M4-0.7×10)	止ネジ	2
3	3500081	Spreader Eccentric, C. Set	飾リエキセン(組)	1
4	3500082	Spreader Eccentric	飾リエキセン	1
5	160003	Screw(M5-0.8×5)	止ネジ	2
6	3500084	Spreader Connecting Rod	飾リロッド	1
7	3230034 [3100309]	Adjusting Lever Pin	調節レバーピン	1
8	000528	Washer	ワッシャ	1
9	100003	Nut(M6-1.0)	ナット	1
10	3500086	Spreader Adjusting Lever	飾り調節レバー	1
11	120013	Screw(M6-1×15)	止ネジ	1
12	3230035	Spreader Driving Shaft	飾り糸ルーパ軸	1
13	0032646	Collar(12×20×8mm)	カラー	1
14	009604	Screw(1 1/64-40×5.5)	止ネジ	2
15	3100305	Rocking Arm	ルーパ振り腕	1
16	160007	Screw(M6-1×6)	止ネジ	2
17	160001	Screw(M4-0.7×4)	止ネジ	2
18	0063051	Rocking Pin	ルーパ振りピン	1
19	3230036	Spreader Bar	ルーパ棒	1
20				
21				
22				
23				
24	3230087	Top Cover Thread Pusher Holder	上飾り糸押シホルダ	1
25	120009	Screw(M4-0.7×12)	止ネジ	1
26	3230086	Top Cover Thread Pusher	上飾り糸押シ	1
27	110009	Screw(M4-0.7×8)	止ネジ	1
28	3230100	Spreader Holder	飾り糸ルーパ台	1
29	110031	Screw(M4-0.7×12)	止ネジ	2
30	3239300	Spreader	飾り糸ルーパ	1
31	300006	Washer	ワッシャ	1

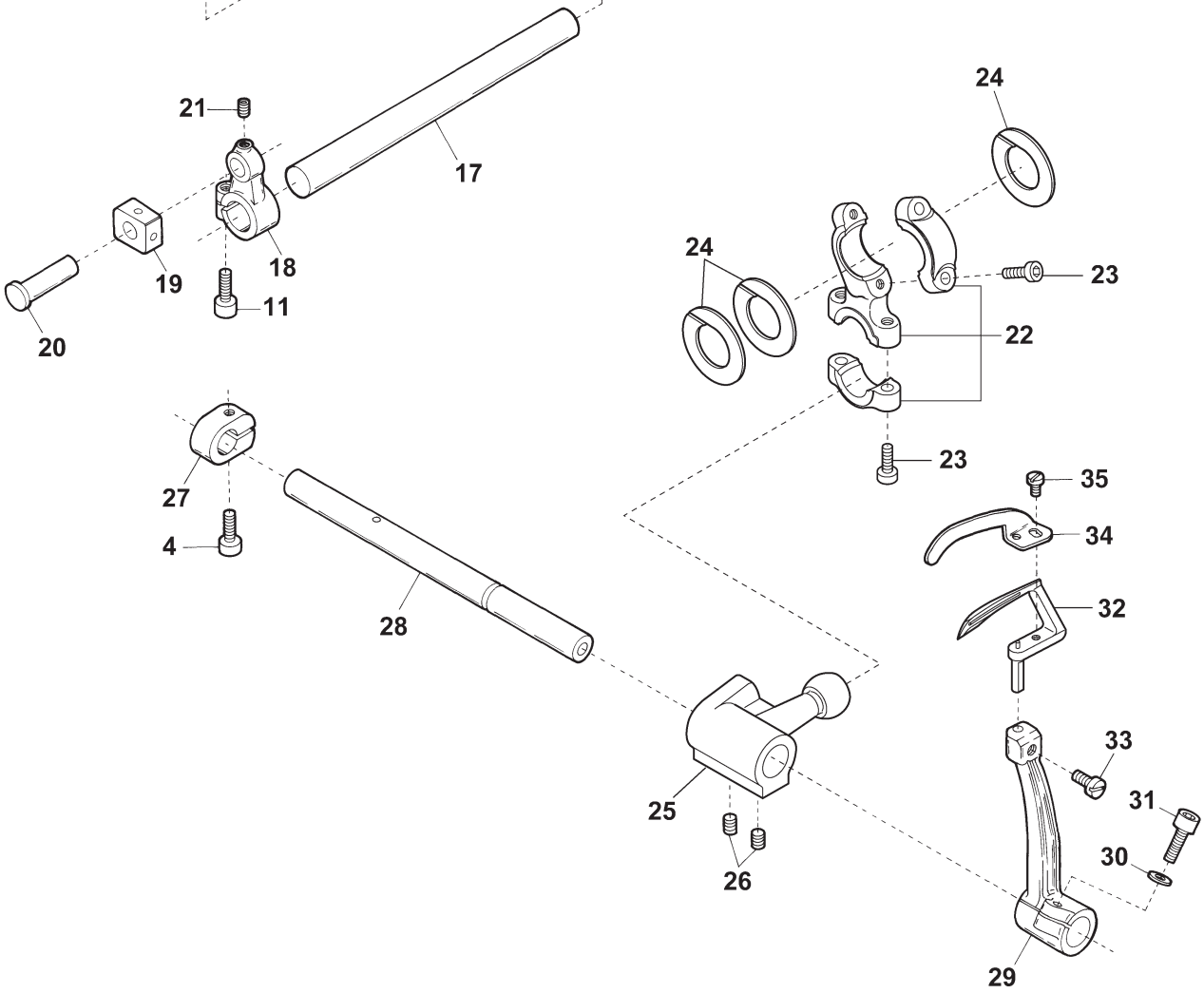
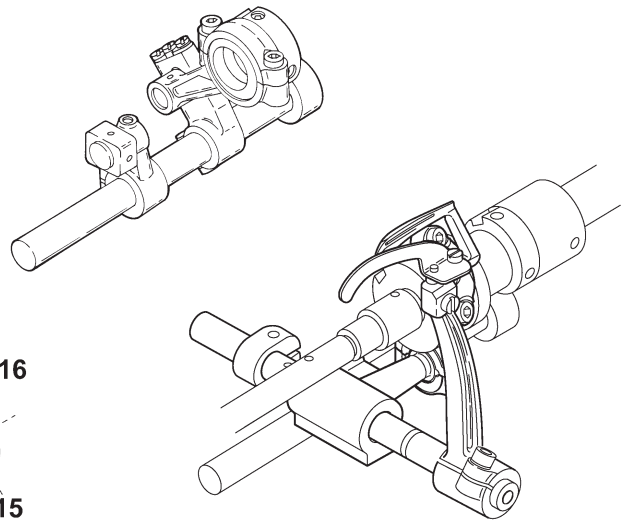
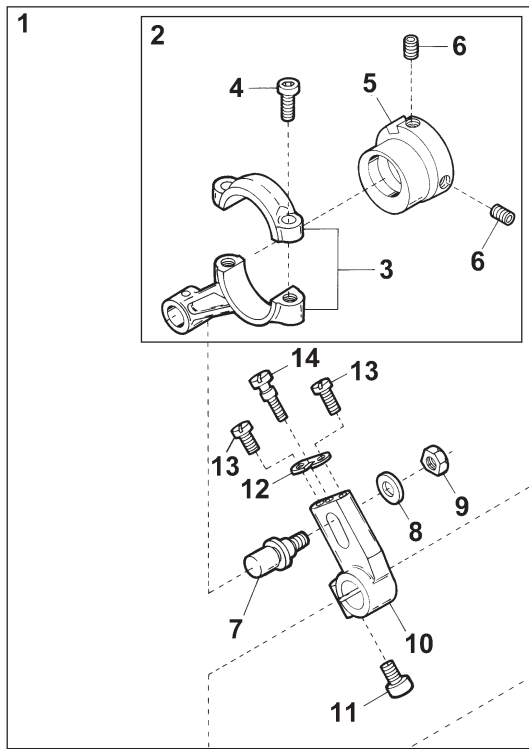

Ref.No.	Parts No.	Description	品 名	Amt. Req
1	3200150	Looper Rocker Connecting Rod, C. Set(2)	ルーパ前後ロッド (組 2)	1
2	3200149	Looper Rocker Connecting Rod, C. Set(1)	ルーパ前後ロッド (組 1)	1
3	3200152	Looper Rocker Connecting Rod	ルーパ前後ロッド	1
4	120001	Screw(M4-0.7×14)	止ネジ	3
5	3200151	Looper Rocker Eccentric	ルーパ前後エキセン	1
6	160003	Screw(M5-0.8×5)	止ネジ	2
7	3200159	Connecting Rod Pin	ルーパ前後ロッドピン	1
8	300000	Washer	ワッシャ	1
9	100002	Nut	ナット	1
10	3200154	Looper Rocker Lever	ルーパ前後腕	1
11	005650	Screw(M5-0.8×14)	止ネジ	2
12	3200155	Looper Rocker Adjusting Guide Plate	ルーパ前後調節ガイド板	1
13	110007	Screw(M2.5-0.45×6)	止ネジ	2
14	170021	Adjusting Screw(M2.5-0.45×10.5)	調節ネジ	1
15	2100267	Collar(10×17×8 mm)	カラー	1
16	160001	Screw(M4-0.7×4)	止ネジ	2
17	0093314	Looper Rocker Shaft	ルーパ前後軸	1
18	3200157	Looper Rocker Arm	ルーパ振り腕	1
19	0093319	Looper Slide Block	ルーパ前後駒	1
20	3200160	Looper Slide Block Pin	ルーパ前後駒ピン	1
21	160009	Screw(M5-0.8×5)	止ネジ	1
22	3230096	Looper Connecting Rod	ルーパロッド	1
23	120009	Screw(M4-0.7×12)	止ネジ	4
24	2100088	Connecting Rod Swing-proof	振れ止め	3
25	3230097	Looper Driving Lever	ルーパ軸腕	1
26	160007	Screw(M6-1×6)	止ネジ	2
27	3200163	Collar	カラー	1
28	0093300	Looper Driving Shaft	ルーパ軸	1
29	3200164	Looper Holder	ルーパ台	1
30	000669	Washer	ワッシャ	1
31	009934	Screw(M5-0.8×16)	止ネジ	1
32	3239310	Looper	ルーパ	1
33	110057	Screw(M4-0.7×7)	止ネジ	1
34	0095723	Needle Guard(Front)	針受ケ (前)	1
35	004236	Screw(3/32-56×4.2)	止ネジ	1

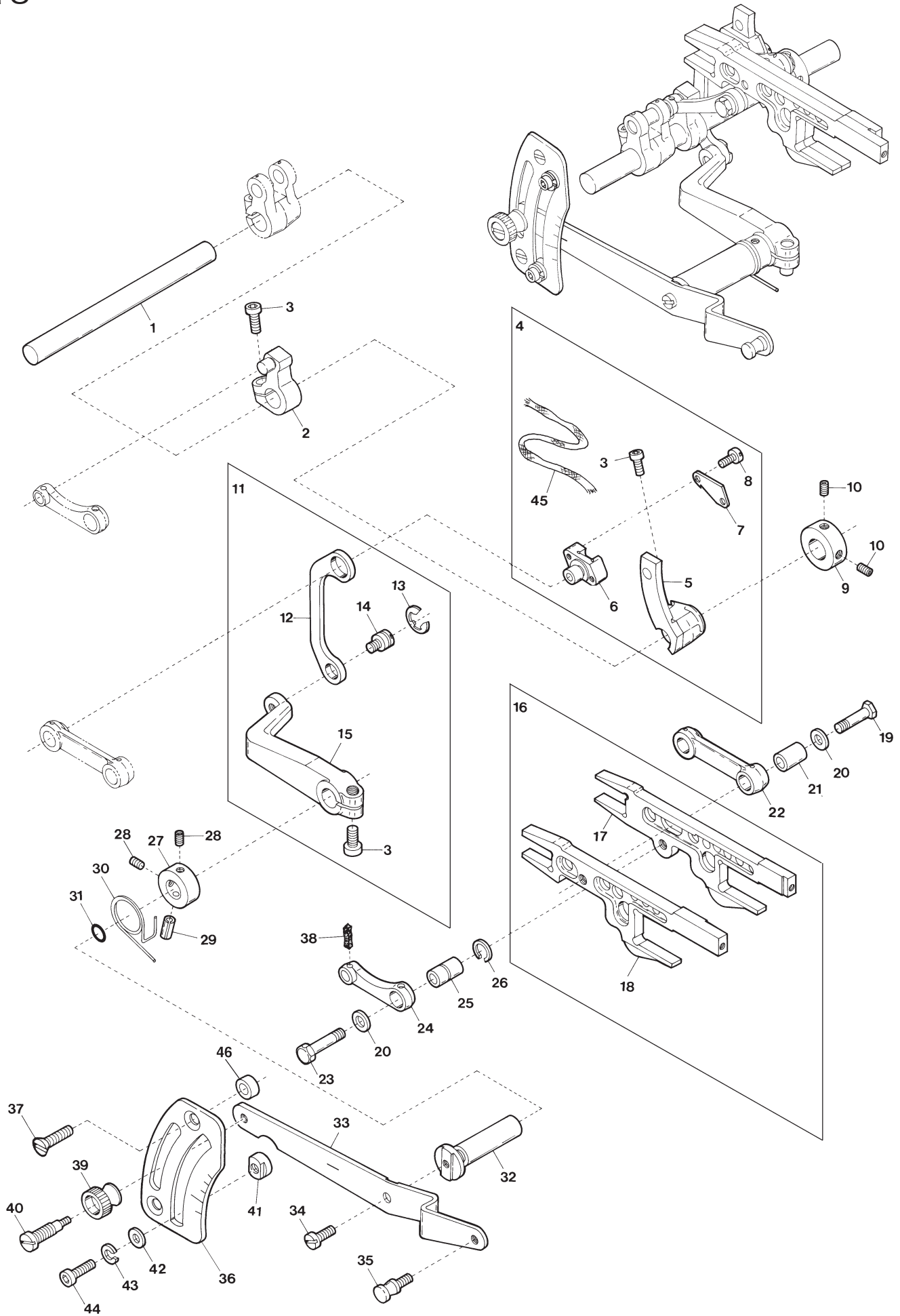

Ref.No.	Parts No.	Description	品 名	Amt. Req
1	3201141 [3200181]	Feed Bar Driving Shaft	送り軸	1
2	3201098	Main Feed Bar Lever	後送りレバー	1
3	120006	Screw(M6-1 × 12)	止ネジ	3
4	3200184	Differential Rocker, Complete Set	前送り腕 (組)	1
5	3200185	Differential Rocker	前送り腕	1
6	3200186	Differential Regulating Slider	スライダ	1
7	3200187	Differential Regulating Slider Cap	スライダ蓋	1
8	110033	Screw(M3-0.5 × 6)	止ネジ	2
9	2100161	Collar(10 × 19 × 9mm)	カラー	1
10	160003	Screw(M5-0.8 × 5)	止ネジ	2
11	3200205	Differential Lever(Inner), C. Set	差動レバー (中) (組)	1
12	2100252	Slider Link	スライダリンク	1
13	0068202	Retaining Ring	ストップリング	1
14	2100253	Slider Link Pin	スライダリンクピン	1
15	3200206	Differential Lever(Inner)	差動レバー (中)	1
16	3200189	Feed Bar, Complete Set	前後送り台 (組)	1
17	3200190	Main Feed Bar	後送り台	1
18	3200191	Differential Feed Bar	前送り台	1
19	140018	Screw(M5-0.5 × 6)	止ネジ	1
20	300000	Washer	ワッシャ	2
21	3200194	Connection Bushing	前送りリンクブッシュ	1
22	2100243	Differential Feed Bar Connection	前送りリンク	1
23	140017	Screw(M5-0.5 × 6)	止ネジ	1
24	2100248	Main Feed Bar Connection	後送りリンク	1
25	3200192	Connection Bushing	後送りリンクブッシュ	1
26	3200215	Retaining Ring	ストップリング	1
27	2100267	Collar(10 × 17 × 8mm)	カラー	1
28	160001	Screw(M4-0.7 × 4)	止ネジ	2
29	000690	Roll Pin	ロールピン	1
30	3200216	Differential Lever Spring	差動レバーバネ	1
31	0020538	O-ring(P7)	Oリング	1
32	3200207	Differential Lever Shaft	差動レバー軸	1
33	0095132	Differential Lever(Left)	差動レバー (左)	1
34	110009	Screw(M4-0.7 × 8)	止ネジ	1
35	004143	Screw(1 1/64-40 × 3.2)	鎖掛ケネジ	1
36	3201099	Differential Feed Graduation	送り目盛板	1
37	130004	Screw(M4-0.7 × 14)	止ネジ	2
38	310072	Felt	フェルト	1
39	000210	Adjusting Nut	調節ナット	1
40	005511	Adjusting Screw(1/4-40 × 11, 11/64-40 × 4)	調節ネジ	1
41	0020350	Differential Lever Stop	差動レバーストップ	2
42	000669	Washer	ワッシャ	2
43	000600	Spring Washer	スプリングワッシャ	2
44	005049	Screw(M5-0.8 × 8)	止ネジ	2
45	310071	Oil Wick	油芯	1
46	000505	Spacer	スペーサ	2

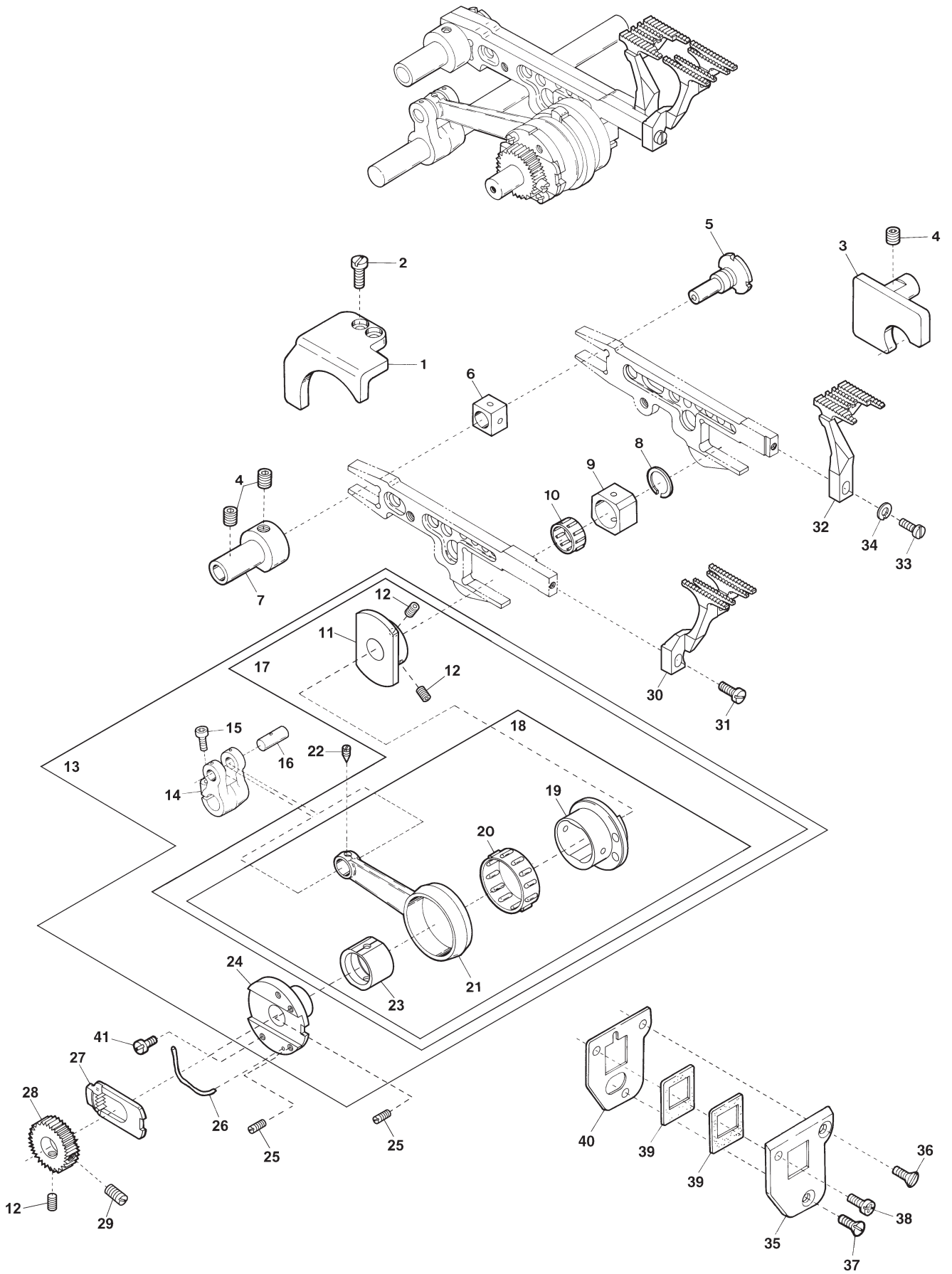

Ref.No.	Parts No.	Description	品名	Amt. Req
1	3200199	Feed Bar Guide(Left)	送り台ガイド (左)	1
2	110009	Screw(M4-0.7×8)	止ネジ	2
3	3200200	Feed Bar Guide(Right)	送り台ガイド (右)	1
4	160007	Screw(M6-1 × 6)	止ネジ	3
5	0033141	Feed Adjusting Pin	エキセンピン	1
6	0093389	Feed Bar Block(Rear)	角駒 (後)	1
7	3200201	Feed Bar Guide(Rear)	送り台ガイド (後)	1
8	0060076	Retaining Ring	ストップリング	1
9	0060075	Feed Bar Block(Front)	角駒 (前)	1
10	2110527	Roller Bearing	ニードルベアリング	1
11	3204065	Feed Dog Regulator, C. Set	送り調節器	1
12	160003	Screw(M5-0.8×5)	止ネジ	3
13	3204059	Driving Connecting Rod Mechanism, C. Set	送りロッド機構 (組)	1
14	3200182	Feed Bar Driving Shaft Lever	送り軸腕	1
15	120006	Screw(M6-1×12)	止ネジ	1
16	2100173	Connecting Rod Pin	送りロッドピン	1
17	3204060	Feed Dog Regulator, C. Set	送り調節器 (組)	1
18	3204061	Driving Connecting Rod, C. Set	送りロッド (組)	1
19	3204064	Feed Dog Eccentric	送りエキセン	1
20	2100278	Roller Bearing	ニードルベアリング	1
21	3200196	Feed Dog Driving Connecting Rod	送りロッド	1
22	160016	Screw(M4-0.7×4.5)	止ネジ	1
23	3204063	Eccentric Link	エキセンリンク	1
24	3204062	Feed Dog Regulating Eccentric	送り調節エキセン	1
25	180002	Screw(M3-0.5×4)	止ネジ	2
26	2100289	Feed Dog Regulating Plate Spring	送り調節プレートバネ	1
27	0023473	Feed Dog Regulating Plate	送り調節プレート	1
28	2100279	Feed Dog Regulating Gear	送り調節ギア	1
29	180003	Screw(M5-0.8×8)	止ネジ	1
30	3239000	Differential Feed Dog(52, 60)	前送り	1
31	110004	Screw(M3.5-0.6×8)	止ネジ	1
32	3239001	Main Feed Dog(52, 60)	後送り	1
33	110039	Screw(M3.5-0.6×10)	止ネジ	1
34	300050	Spring Washer	スプリングワッシャ	1
35	3200203	Feed Bar Shield Holder(Front)	送り台シール支エ (前)	1
36	130003	Screw(M4-0.7×7.3)	止ネジ	1
37	130024	Screw(M4-0.7×7.3)	止ネジ	1
38	110079	Screw(M4-0.7×8)	止ネジ	1
39	3200211	Feed Bar Shield	送り台シール	2
40	3200204	Feed Bar Shield Holder(Rear)	送り台シール支エ (後)	1
41	110070	Screw(M3-0.5×6.3)	止ネジ	1

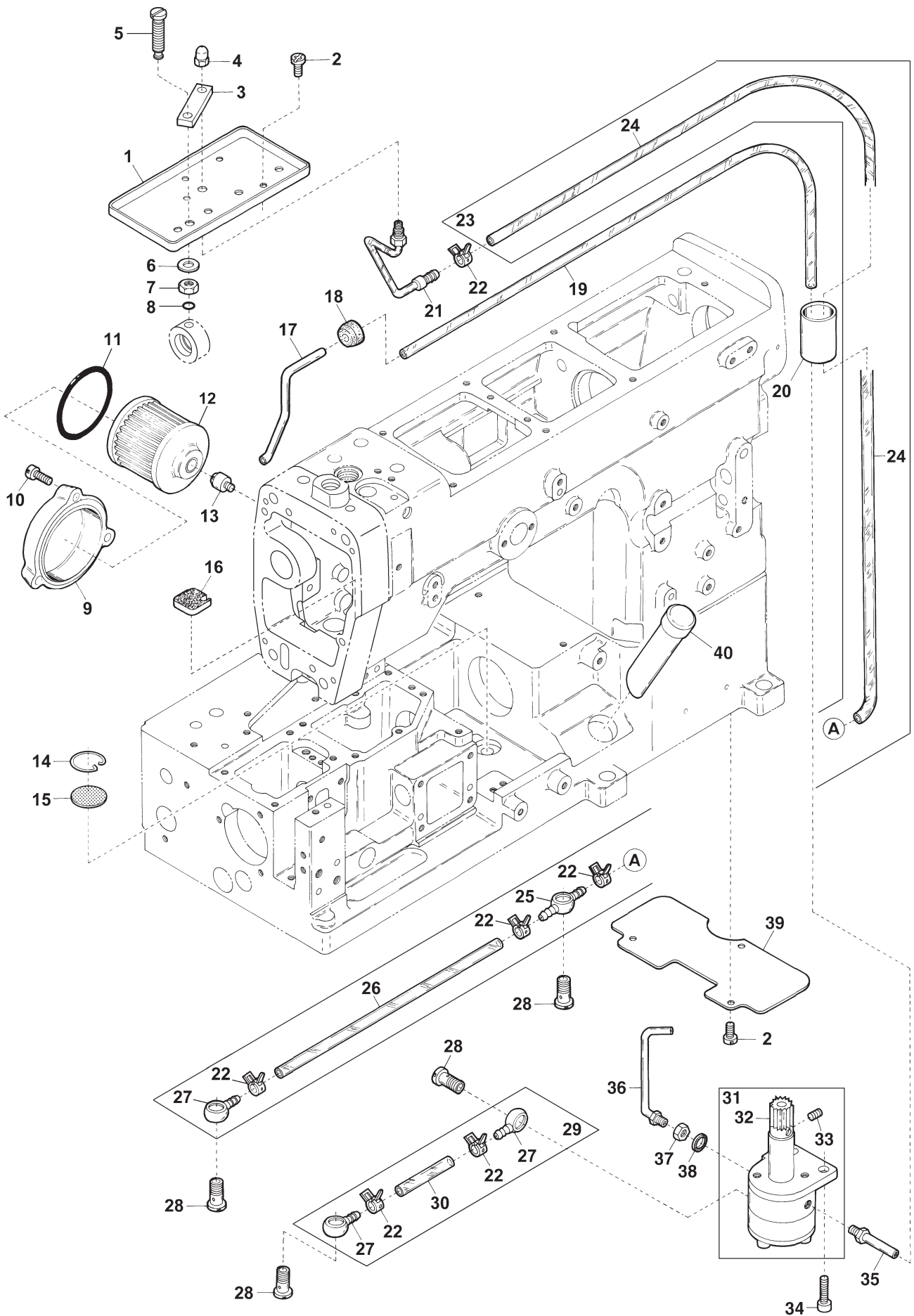

Ref.No.	Parts No.	Description	品 名	Amt. Req
1	0065453	Oil Receiver	油受ケ皿	1
2	110012	Screw(M4-0.7×5)	止ネジ	5
3	3200243	Lubricant Guiding Block	給油ブロック	1
4	320006	Top Nozzle Cap	オイルノズルキャップ	1
5	3201532	Oil Adjusting Screw	給油量調節ネジ	1
6	000425	Washer	ワッシャ	1
7	100003	Nut	ナット	1
8	0032518	O-ring(P3)	Oリング	1
9	2150325	Oil Filter Cap	オイルフィルタキャップ	1
10	110045	Screw(M4-0.7×12)	止ネジ	3
11	3100061	O-ring(P42)	Oリング	1
12	3100345	Oil Filter	オイルフィルタ	1
13	3100329	Oil Filter Connector	オイルフィルタ継手	1
14	0063217	Oil Filter Screen Clamp	濾過網押エ	1
15	0063216	Oil Filter Screen	濾過網	1
16	3200237	Felt	フェルト	1
17	3200236	Suction Pipe	吸入パイプ	1
18	0093617	Suction Pipe Bushing	吸入パイプブッシュ	1
19	3200238	Oil Tube(3×5×440mm)	オイルパイプ	1
20	0065452	Drining Pipe	排油パイプ	1
21	3200227	Oil Pipe Unit	給油パイプ(組)	1
22	0031831	Oil Tube Clamp	緊束環	6
23	3200234	Oil Tube(Long), Complete Set	給油パイプ(長)(組)	1
24	3100372	Oil Tube(4×6×290mm)	オイルパイプ	1
25	3100371	Oil Tube Joint, Two Way	両口管継手	1
26	3200233	Oil Tube(4×6×175mm)	オイルパイプ	1
27	3100370	Oil Tube Joint, One Way	片口管継手	3
28	320020	[320010] Fitting Stud(Short)	管継手ボルト(短)	4
29	3200235	Oil Tube(Short), Complete Set	給油パイプ(短)(組)	1
30	3200232	Oil Tube(4×6×45mm)	オイルパイプ	1
31	3100328	Oil Pump, Complete Set	ポンプ(組)	1
32	0030711	Oil Pump Driving Worm Gear	ウオームギア	1
33	160001	Screw(M4-0.7×4)	止ネジ	2
34	120013	Screw(M6-1×15)	止ネジ	2
35	0090918	Suction Pipe	吸入パイプ	1
36	3100349	Oil Nozzle for Worm Gear	給油パイプ	1
37	000419	Nut	ノズル止メナット	1
38	000567	Seal	パッキン	1
39	3200231	Dustproof Plate	防塵板	1
40	0020533	Oil Sight Gauge	オイルゲージ	1

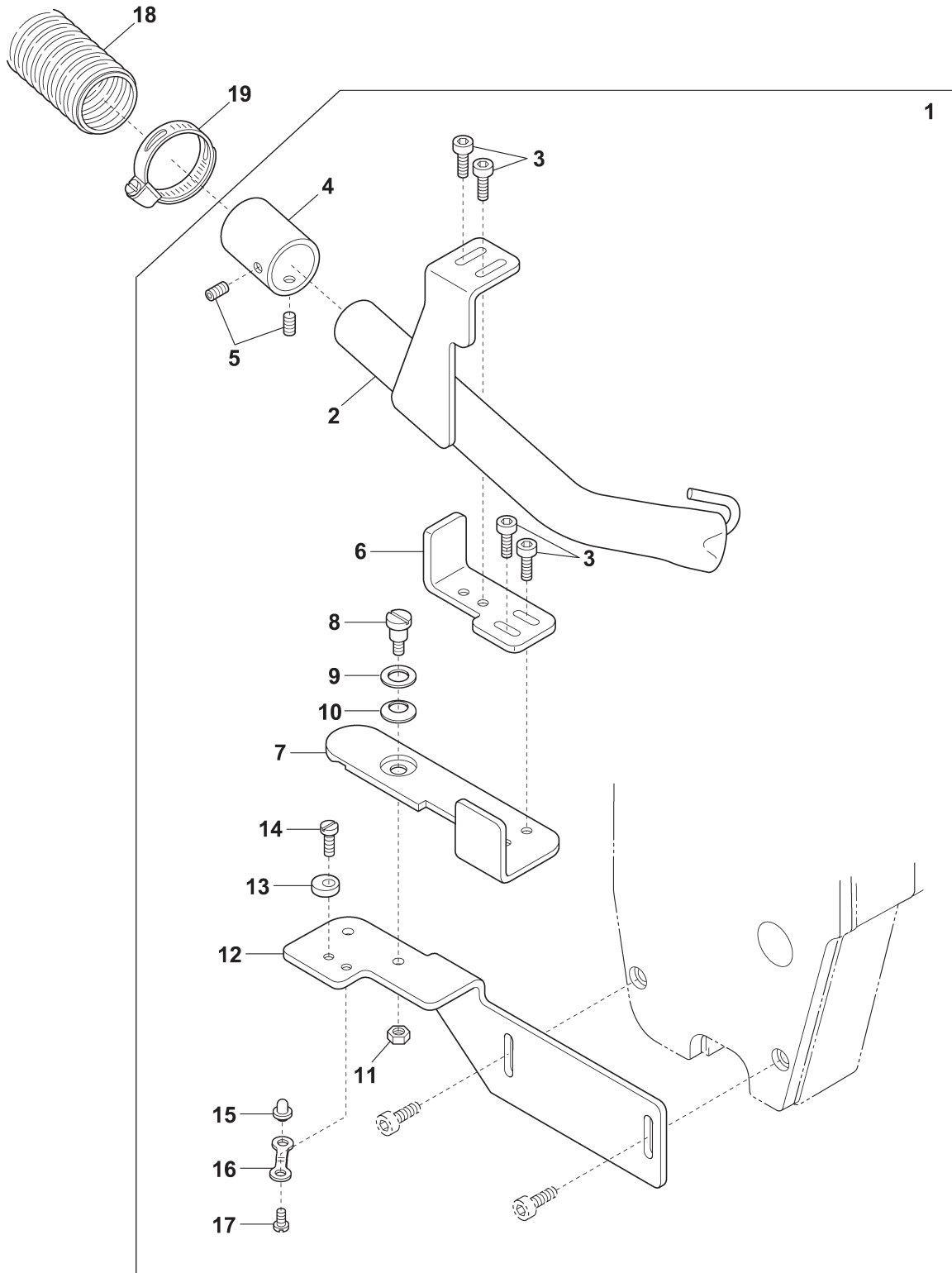

Ref.No.	Parts No.	Description	品 名	Amt. Req
1	3239900	SC30 Device	SC30 装置	1
2	3231000	Suction Pipe	吸込管	1
3	006202	Screw(M4-0.7×6)	止ネジ	4
4	3231006	Suction Pipe Adapter	アダプタ	1
5	160001	Screw(M4-0.7×4)	止ネジ	2
6	3231005	Adjusting Position Plate	吸込管前後調節板	1
7	3231004	Suction Pipe Locking Plate	吸込管回り止め板	1
8	170044	Screw(M4-0.7×7)	止ネジ	1
9	000425	Washer	ワッシャ	1
10	000010	Conical Spring Washer	皿バネワッシャ	1
11	000015	Nut	ナット	1
12	3231003	Suction Pipe Holder	吸込管取付台	1
13	0022448	Suction Pipe Stopper	吸込管ストッパ	1
14	110036 [110033]	Screw(M3-0.5×6.5)[M3-0.5×6]	止ネジ	1
15	0022435	Suction Pipe Positioning Pin	吸込管固定ピン	1
16	0022436	Positioning Pin Holder Spring	吸込管固定ピン押エバネ	1
17	110002	Screw(M3-0.5×5)	止ネジ	1
18	0012480	Dust Hose(1500mm)	集塵ホース	1
19	1253061	Hose Clamp	ホース止め	1

17

K1 DEVICE

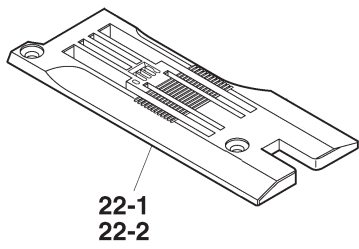
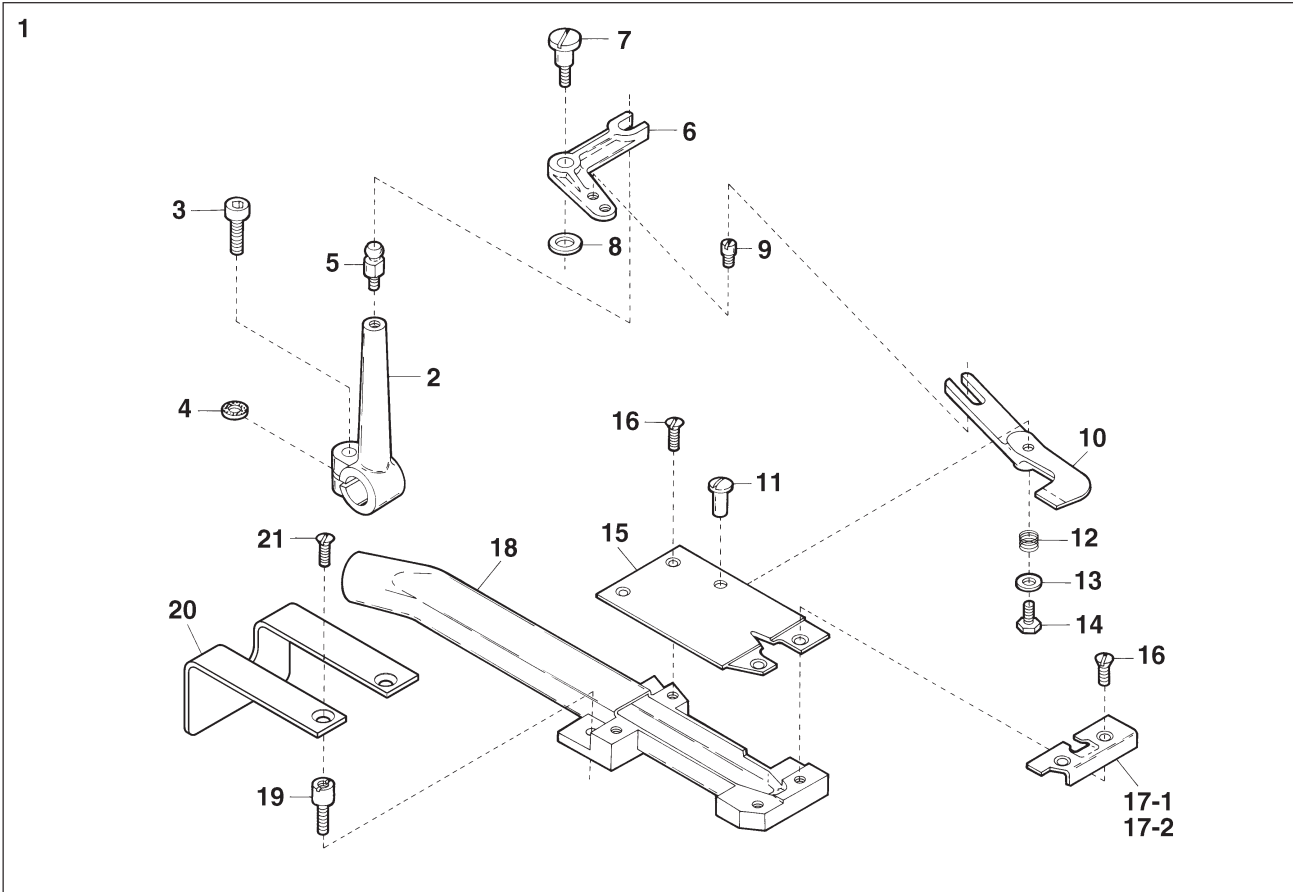

Ref.No.	Parts No.	Description	品 名	Amt. Req
1	3239902	K1 Device, Complete Set	K1 装置 (組)	1
2	3201140	Cutting Knife Main Lever	メインレバー	1
3	120006	Screw(M6-1 × 12)	止ネジ	1
4	000567	Packing Piece	ファイバパッキン	1
5	3201142	Ball Stud	球	1
6	0095466	Cutting Knife Driving Link	下刃リンク	1
7	170029	Screw(M4-0.7 × 8)	止ネジ	1
8	300017	Washer	ワッシャ	1
9	005572	Screw(9/64-40 × 3.57)	止ネジ	1
10	0095463	Cutting Knife(Lower)	下刃	1
11	0095465	Cutting Knife Holder Pin	下刃支持ピン	1
12	0095464	Cutting Knife(Lower) Spring	下刃バネ	1
13	000014	Washer	ワッシャ	1
14	005571	Screw(3/32-56 × 4)	止ネジ	1
15	0095462	Cutting Plate	カッティングプレート	1
16	005328	Screw(29/256-48 × 6.5)	止ネジ	4
17-1	0095471	Cahin-off Guide(Small Mouth)	口金 (小)	1
17-2	0095472	Cahin-off Guide(Large Mouth)	口金 (大)	1
18	0095458	Suction Pipe Unit	吸込管 (組)	1
19	190107	Screw(M4-0.7 × 8)	止ネジ	2
20	3231010	Supplementary Cover	補助カバー	1
21	130023	Screw(M3-0.5 × 3.5)	止ネジ	2
22-1	3238010	Stitch Plate(52)	針板	1
22-2	3238011	Stitch Plate(60)	針板	1

1

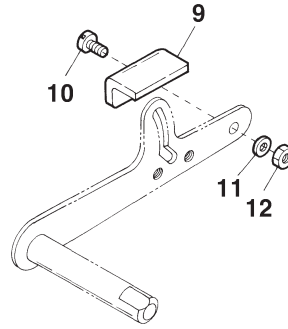
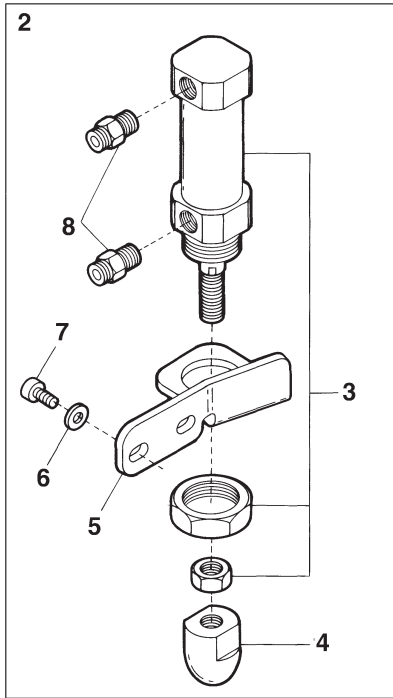

Ref.No.	Parts No.	Description	品 名	Amt. Req
1	3239901	FL Device, C. Set	FL 装置 (組)	1
2	3101244	Presser Foot Lifter Cylinder, C. Set	押工揚ゲシリンダ (組)	1
3	1091146	Air Cylinder	押工揚ゲシリンダ	1
4	3201037	Cylinder Rod Chip	シリンダロッドチップ	1
5	3101243	Cylinder Bracket	シリンダ台	1
6	000425	Washer	ワッシャ	2
7	120013	Screw(M6-1 × 15)	止ネジ	2
8	0010055	Connector(φ4-PT1/8)	コネクタ	2
9	3201038	Lifter Lever Supplementary Plate	押工揚ゲレバー補助板	1
10	005650	Screw(M5-0.8 × 14)	止ネジ	1
11	000426	Washer	ワッシャ	1
12	000009	Nut	ナット	3

SUPPORTING BOARD(1)

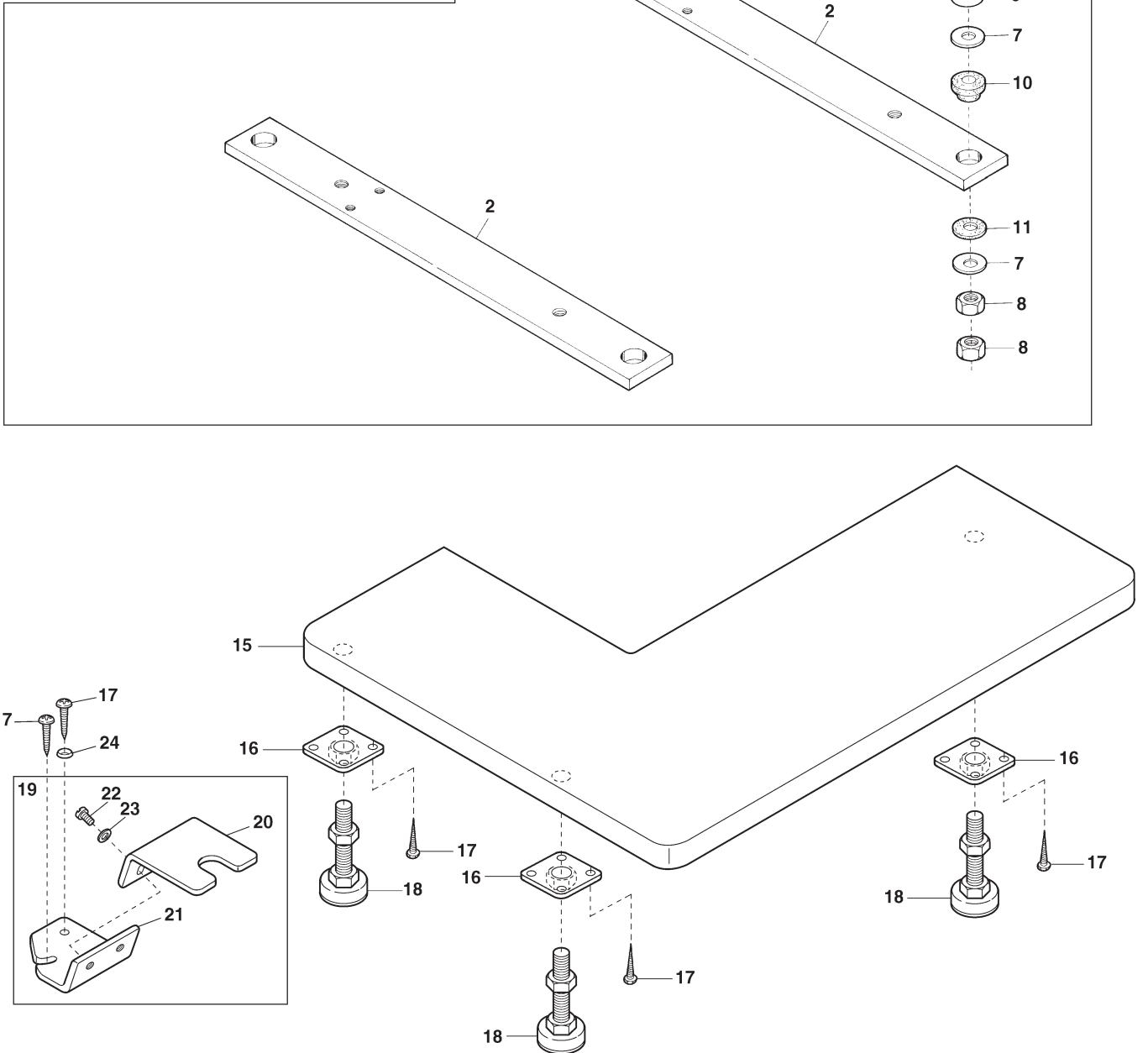
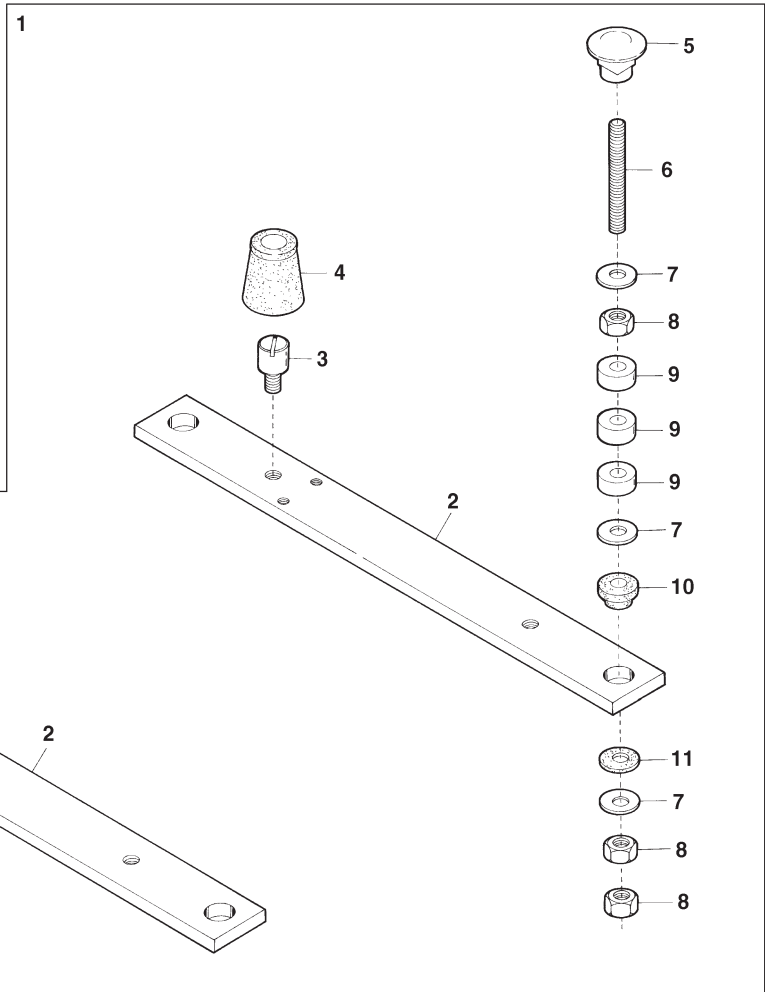
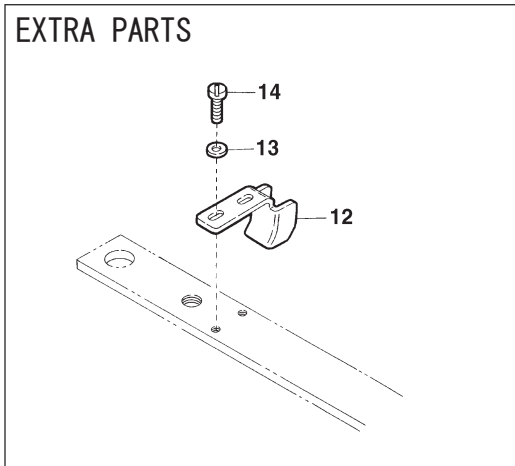

Ref.No.	Parts No.	Description	品 名	Amt. Req
1	3200240	Supporting Board, C. Set	受ケ板 (組)	1
2	3200241	Supporting Board	受ケ板	2
3	180020	Setting Screw(M6-1×15)	取付ケネジ	4
4	0093035	Oil Reservoir Rubber Cushion	ゴム座	4
5	000070	Hanging Nut	吊リナット	4
6	009861	Hanging Bolt(M8-1.25×95)	吊リボルト	4
7	000162	Washer	ワッシャ	12
8	000016	Nut	ナット	12
9	2101451	Spacer(See the table below)	スペーサ (下表参照)	12
10	0020064	Supporting Board Rubber Cushion	受ケ板ゴム座	4
11	0063010	Supporting Board Rubber Cushion(Lower)	受ケ板ゴム座 (下)	4
12	3200242	Chain Guide	鎖ガイド	1
13	000541	Washer	ワッシャ	2
14	110009	Screw(M4-0.7×8)	止ネジ	2
15	9603085	Supplementary Table	補助テーブル	1
16	3231051	Adjustable Foot Plate	アジャスタブルフット取付板	3
17	009938	Wood Screw(Φ4.1×16)	木ネジ	14
18	3231050	Adjustable Foot	アジャスタブルフット	3
19	3231052	Supplementary Table Stay, C. Set	補助テーブル固定板 (組)	1
20	3231053	Supplementary Table Stay(Upper)	補助テーブル固定板 (上)	1
21	3231054	Supplementary Table Stay(Lower)	補助テーブル固定板 (下)	1
22	110013	Screw(M4-0.7×8)	止ネジ	2
23	000665	Washer	ワッシャ	2
24	000670	Washer	ワッシャ	1

Note : Number of Spacer(2101451) to be used.

(注) スペーサ (2101451) の使用個数

Thickness of Table テーブルの厚さ	Number of Spacer スペーサの個数
for 40 mm	3 pcs. × 4=12 pcs.
for 45 mm	2 pcs. × 4= 8 pcs.
for 50 mm	1 pcs. × 4= 4 pcs.

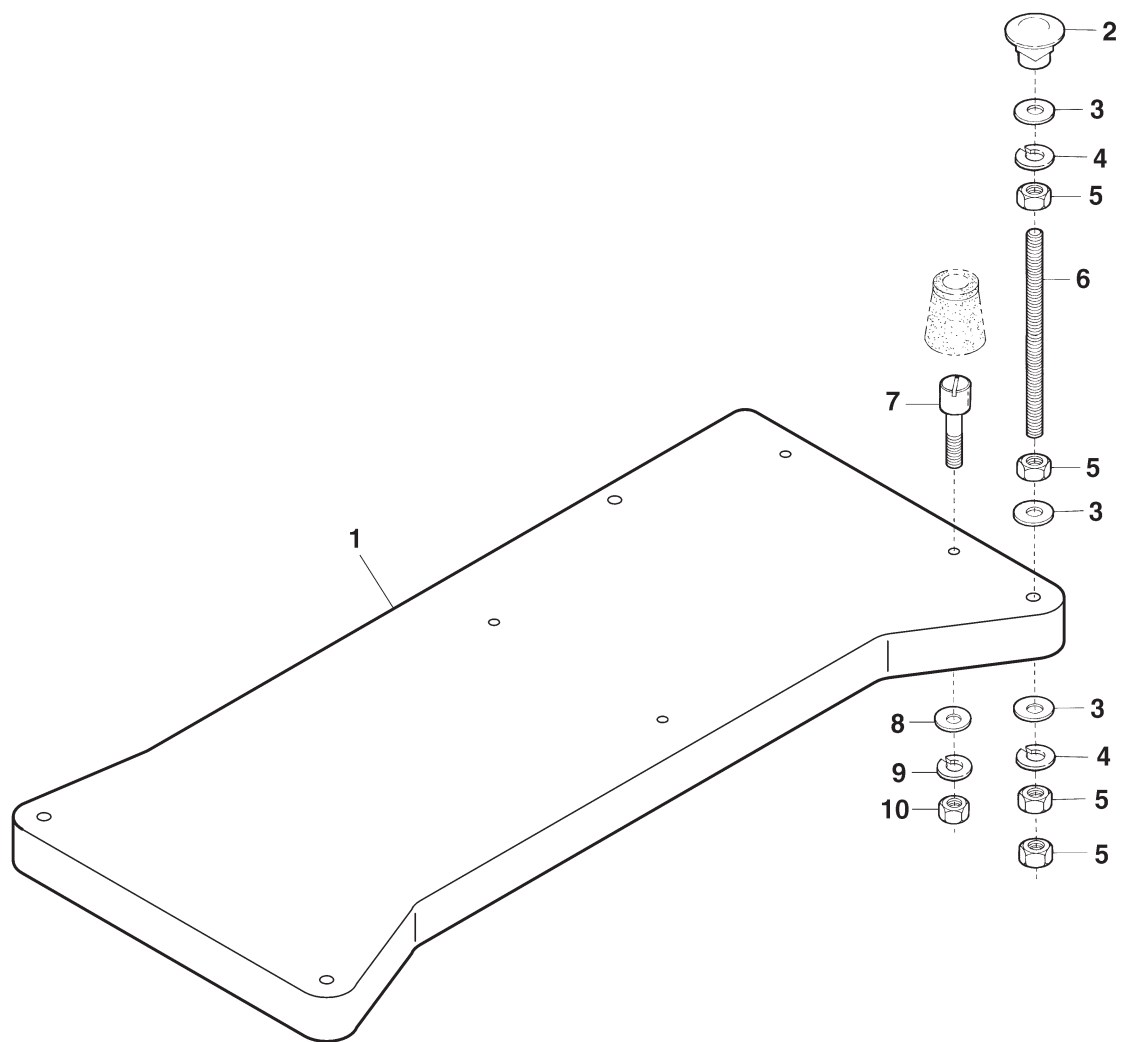

Ref.No.	Parts No.	Description	品 名	Amt. Req
1	9603082 [9603903]	Supporting Board	受け板	1
2	000070	Hanging Nut	吊リナット	4
3	000162	Washer	ワッシャ	12
4	000676	Spring Washer	スプリングワッシャ	8
5	000016	Nut	ナット	16
6	009865	Hanging Bolt(M8-1.25×220)	吊リボルト	4
7	180024	Screw(M6-1 × 45)	止ネジ	4
8	000528	Washer	ワッシャ	4
9	000667	Spring Washer	スプリングワッシャ	4
10	000011	Nut	ナット	4

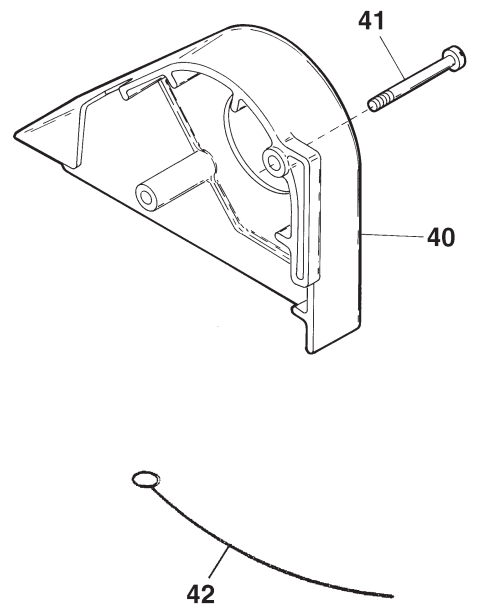
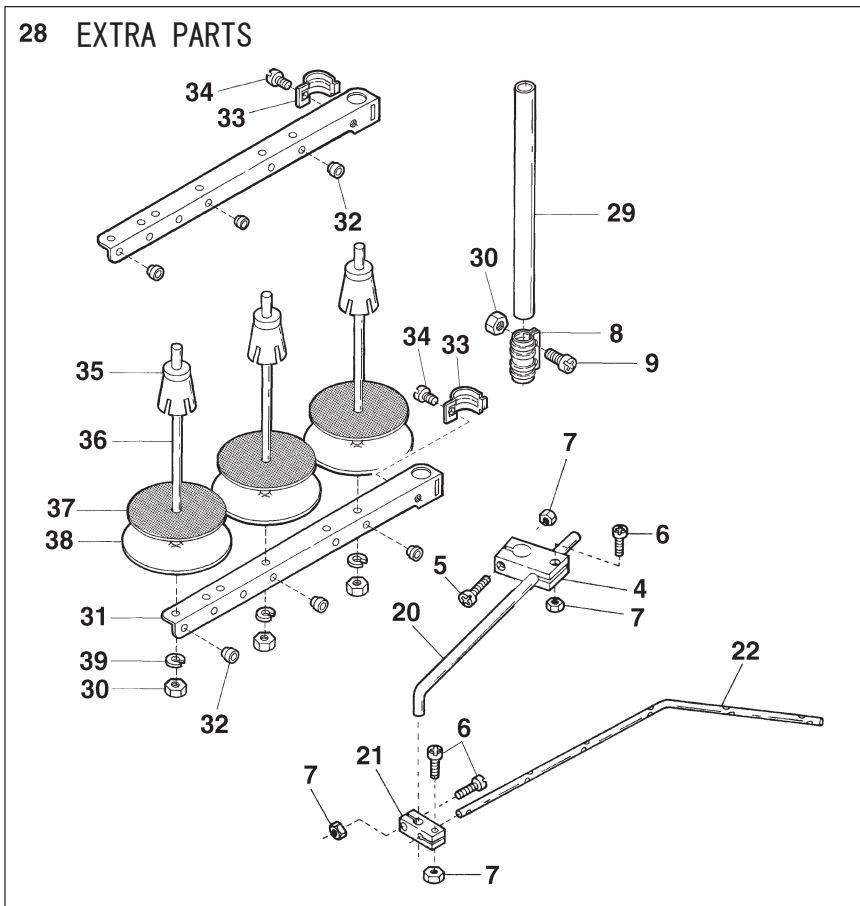
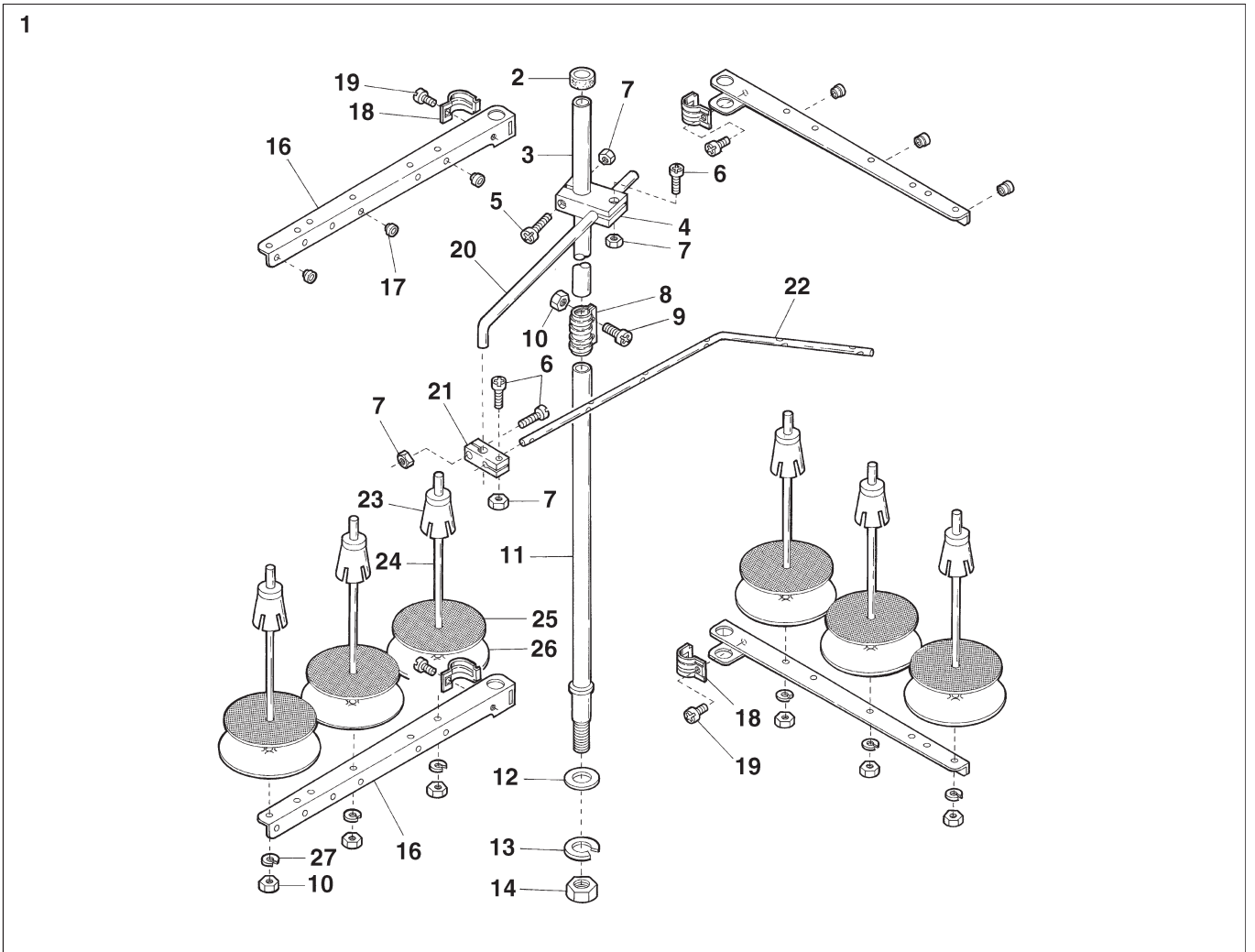

Ref.No.	Parts No.	Description	品 名	Amt. Req
1	9620696	Thread Stand, C. Set(6 Spools Type)	糸立台(組)(6本糸用)	1
2	9620631	Column Cap	コラムキャップ	1
3	9620670	Column Pipe(Upper)	コラムパイプ(上)	1
4	9620689	Thread Guide Holder(Large)	ガイドホルダ(大)	1
5	911002	Screw(M4-0.7×20)	止ネジ	1
6	911001	Screw(M4-0.7×12)	止ネジ	3
7	910001	Nut	ナット	4
8	9620673	Column Pipe Connector	コラムパイプ継手	1
9	911006	Screw(M5-0.8×13)	止ネジ	2
10	910000	Nut	ナット	8
11	9620675	Column Pipe(Lower)	コラムパイプ(下)	1
12	930052	Washer	ワッシャ	1
13	930053	Spring Washer	スプリングワッシャ	1
14	910003	Nut(M16-1.5)	ナット	1
15				
16	9620703	Thread Hanger(3 Spools Type)	スレッドハンガ(3本糸用)	4
17	9620700	Thread Eyelet	アイレット	6
18	9620688	Thread Hanger Holder	スレッドハンガ抱キ	4
19	911060	Screw(M6-1×15)	止ネジ	4
20	9620691	Thread Guide Arm	ガイドアーム	1
21	9620690	Thread Guide Holder(Small)	ガイドホルダ(小)	1
22	9620666	Thread Guide(6 Spools Type)	スレッドガイド(6本糸用)	1
23	9620678	Spool Cushion	スプールクッション	6
24	9620679	Spool Pin	スプール軸	6
25	9620680	Spool Mat	スプールマット	6
26	9620681	Spool Seat Disc	受ケ皿	6
27	930055	Spring Washer	スプリングワッシャ	6
28	9620650	Thread Stand, C. Set(3 Spools Type)	糸立台(組)(3本糸用)	1
29	9620660	Column Pipe(Short)(206mm)	コラムパイプ(短)	1
30	910000	Nut	ナット	5
31	9620703	Thread Hanger(3 Spools Type)	スレッドハンガ(3本糸用)	2
32	9620700	Thread Eyelet	アイレット	6
33	9620688	Thread Hanger Holder	スレッドハンガ抱キ	2
34	911060	Screw(M6-1×15)	止ネジ	2
35	9620678	Spool Cushion	スプールクッション	3
36	9620679	Spool Pin	スプール軸	3
37	9620680	Spool Mat	スプールマット	3
38	9620681	Spool Seat Disc	受ケ皿	3
39	930055	Spring Washer	スプリングワッシャ	3
40	3530015	Belt Cover	ベルトカバー	1
41	110028	Screw(M6-1×46)	止ネジ	2
42	3000010	Looper Thread Bar	ルーバ糸通シ	2

INDEX

VFK2560-8

Page = 2

<u>Parts No.</u>	<u>Page No.</u>	<u>Ref. No.</u>	<u>Weight(g)</u>	<u>Parts No.</u>	<u>Page No.</u>	<u>Ref. No.</u>	<u>Weight(g)</u>	<u>Parts No.</u>	<u>Page No.</u>	<u>Ref. No.</u>	<u>Weight(g)</u>
0030255	3	3		0068249	3	21		0095462	17	15	
0030711	15	32		0068250	3	26		0095463	17	10	
				0068251	3	30		0095464	17	12	
0031111	3	8		0068252	3	31		0095465	17	11	
0031831	15	22						0095466	17	6	
				0077179	8	29		0095471	17	17-1	
0032518	15	8		0077300	4	17		0095472	17	17-2	
0032604	1	17						0095723	12	34	
0032646	11	13		0090071	3	6					
0032952	3	4		0090801	8	40		100002	12	9	
0032952	3	5		0090807	3	13		100003	11	9	
				0090812	3	10		100003	15	7	
0033024	2	28		0090824	8	43		100014	8	7	
0033141	14	5		0090856	3	12		100030	8	2	
				0090857	3	58					
0035813	3	63		0090918	15	35		110001	2	45	
0035813	5	52						110001	3	50	
				0093035	19	4		110002	7	28	
0037108	3	62		0093091	5	16		110002	16	17	
0037108	5	51		0093154	6	38		110004	14	31	
				0093186	7	22		110005	5	20	
0060057	6	37		0093212	7	17		110007	10	28	
0060075	14	9		0093214	7	14		110007	12	13	
0060076	14	8		0093300	12	28		110009	2	60	
				0093303	4	23		110009	3	46	
0063010	19	11		0093303	4	30		110009	5	42	
0063051	11	18		0093314	12	17		110009	6	26	
0063083	8	21		0093319	12	19		110009	11	27	
0063084	8	23		0093365	7	7		110009	13	34	
0063152	2	25		0093389	14	6		110009	14	2	
0063197	5	54		0093479	8	26		110009	19	14	
0063216	15	15		0093491	8	24		110012	1	20	
0063217	15	14		0093496	8	36		110012	2	41	
				0093500	8	10		110012	3	25	
0065275	2	31		0093507	8	31		110012	6	36	
0065275	4	28		0093508	8	32		110012	15	2	
0065452	15	20		0093509	8	30		110013	1	24	
0065453	15	1		0093515	5	46		110013	2	17	
				0093545	8	42		110013	3	15	
0068011	1	4		0093556	3	44		110013	19	22	
0068117	9	12		0093617	15	18		110016	1	26	
0068121	9	9		0093663	4	36		110016	2	50	
0068181	10	19						110028	21	41	
0068182	10	20		0095108	1	12		110030	2	8	
0068184	10	24		0095132	13	33		110030	9	16	
0068202	5	33		0095214	6	7		110031	8	14	
0068202	13	13		0095218	4	29		110031	11	29	
0068247	3	20		0095458	17	18		110033	13	8	

INDEX

VFK2560-8

Page = 3

<u>Parts No.</u>	<u>Page No.</u>	<u>Ref. No.</u>	<u>Weight(g)</u>	<u>Parts No.</u>	<u>Page No.</u>	<u>Ref. No.</u>	<u>Weight(g)</u>	<u>Parts No.</u>	<u>Page No.</u>	<u>Ref. No.</u>	<u>Weight(g)</u>
110035	2	13		130006	2	21		170029	17	7	
110035	3	18		130016	9	5		170044	16	8	
110035	7	3		130021	2	15		170060	3	68	
110036	2	11		130023	17	21					
110036	5	28		130024	14	37		180002	14	25	
110036	16	14						180003	14	29	
110038	10	30		140010	10	34		180005	1	16	
110039	14	33		140017	13	23		180017	2	55	
110041	2	44		140018	13	19		180018	1	22	
110043	2	10						180018	2	58	
110045	1	2		150000	5	15		180020	19	3	
110045	15	10		150010	7	6		180024	20	7	
110048	2	39						180041	10	26	
110048	5	40		160000	5	26					
110054	3	42		160000	9	7		190101	9	8	
110054	3	60		160001	2	54		190105	7	33	
110057	12	33		160001	5	31		190107	17	19	
110070	14	41		160001	10	29					
110079	2	35		160001	11	17		260000	7	12	
110079	14	38		160001	12	16					
110083	5	38		160001	13	28		290029	3	9	
110135	6	32		160001	15	33					
				160001	16	5		300000	12	8	
120001	6	18		160003	5	22		300000	13	20	
120001	12	4		160003	6	16		300006	11	31	
120006	13	3		160003	11	5		300017	17	8	
120006	14	15		160003	12	6		300050	14	34	
120006	17	3		160003	13	10		300067	6	24	
120008	9	28		160003	14	12		300100	1	15	
120009	11	25		160004	6	40		300100	2	53	
120009	12	23		160005	5	2					
120011	10	15		160005	6	6		310035	5	30	
120013	6	20		160007	5	3		310036	4	35	
120013	11	11		160007	6	2		310071	13	45	
120013	15	34		160007	10	2		310072	13	38	
120013	18	7		160007	11	16		310099	6	35	
120015	6	30		160007	12	26		310132	6	33	
120015	7	13		160007	14	4		310137	3	35	
120015	9	24		160009	9	3					
120017	8	28		160009	12	21		320006	15	4	
120018	11	2		160016	14	22		320020	15	28	
120053	10	7		160021	8	5					
120066	2	20		160023	7	26		330000	1	21	
				160041	6	34		330000	7	18	
130002	5	44						330011	2	56	
130003	14	36		170001	1	14		330011	2	61	
130004	2	2		170020	2	52					
130004	13	37		170021	12	14		340014	8	37	

INDEX

VFK2560-8

Page = 4

<u>Parts No.</u>	<u>Page No.</u>	<u>Ref. No.</u>	<u>Weight(g)</u>	<u>Parts No.</u>	<u>Page No.</u>	<u>Ref. No.</u>	<u>Weight(g)</u>	<u>Parts No.</u>	<u>Page No.</u>	<u>Ref. No.</u>	<u>Weight(g)</u>
340016	1	30						3200026	2	47	
				3000010	21	42		3200027	2	48	
390242	1	10						3200028	2	36	
				3027087	9	18		3200029	2	37	
910000	21	10		3027238	9	29		3200030	2	38	
910000	21	30		3027310	9	13		3200031	2	42	
910001	21	7						3200033	1	18	
910003	21	14		3040038	1	13		3200042	3	43	
				3040039	1	11		3200042	5	49	
911001	21	6		3040040	2	49		3200050	4	13	
911002	21	5						3200051	4	25	
911006	21	9		3100006	2	33		3200052	4	16	
911060	21	19		3100061	15	11		3200053	4	20	
911060	21	34		3100113	2	34		3200055	4	26	
				3100127	6	11		3200056	4	18	
930052	21	12		3100128	5	7		3200057	4	19	
930053	21	13		3100129	5	10		3200061	4	24	
930055	21	27		3100129	6	5		3200062	4	15	
930055	21	39		3100131	5	8		3200065	4	21	
				3100131	6	4		3200067	4	14	
1091146	18	3		3100275	6	9		3200070	5	1	
				3100281	6	8		3200072	5	9	
1253061	16	19		3100283	6	10		3200073	5	12	
				3100294	8	27		3200074	5	13	
2100034	4	22		3100305	11	15		3200077	5	27	
2100065	3	38		3100328	15	31		3200078	5	11	
2100088	12	24		3100329	15	13		3200082	5	19	
2100161	13	9		3100345	15	12		3200083	5	36	
2100173	14	16		3100349	15	36		3200084	5	24	
2100218	6	27		3100370	15	27		3200085	5	34	
2100243	13	22		3100371	15	25		3200086	5	35	
2100248	13	24		3100372	15	24		3200087	5	23	
2100252	13	12						3200090	7	25	
2100253	13	14		3101216	8	38		3200091	5	43	
2100267	12	15		3101243	18	5		3200092	5	41	
2100267	13	27		3101244	18	2		3200093	5	39	
2100278	14	20						3200094	5	56	
2100279	14	28		3160136	4	10		3200095	5	6	
2100289	14	26		3160168	8	34		3200096	5	18	
2101451	19	9						3200097	5	17	
				3200007	1	31		3200098	5	21	
2110527	14	10		3200012	1	19		3200101	7	11	
				3200013	1	23		3200112	7	16	
2150030	3	33		3200016	2	57		3200113	7	20	
2150031	3	36		3200022	2	23		3200114	7	15	
2150107	3	66		3200023	2	30		3200115	7	10	
2150108	3	67		3200024	2	18		3200116	7	23	
2150325	15	9		3200025	2	19		3200118	7	21	

INDEX

VFK2560-8

Page = 5

<u>Parts No.</u>	<u>Page No.</u>	<u>Ref. No.</u>	<u>Weight(g)</u>	<u>Parts No.</u>	<u>Page No.</u>	<u>Ref. No.</u>	<u>Weight(g)</u>	<u>Parts No.</u>	<u>Page No.</u>	<u>Ref. No.</u>	<u>Weight(g)</u>
3200120	4	32		3200238	15	19		3230030	2	12	
3200121	4	33		3200240	19	1		3230032	7	32	
3200122	4	34		3200241	19	2		3230034	11	7	
3200137	8	19		3200242	19	12		3230035	11	12	
3200143	5	14		3200243	15	3		3230036	11	19	
3200149	12	2		3200245	1	32		3230037	11	1	
3200150	12	1						3230038	7	27	
3200151	12	5		3201037	18	4		3230039	10	1	
3200152	12	3		3201038	18	9		3230040	10	5	
3200154	12	10		3201098	13	2		3230041	10	6	
3200155	12	12		3201099	13	36		3230042	10	4	
3200157	12	18						3230043	10	10	
3200159	12	7		3201140	17	2		3230044	10	13	
3200160	12	20		3201141	13	1		3230046	10	8	
3200163	12	27		3201142	17	5		3230047	10	12	
3200164	12	29		3201162	3	11		3230051	10	22	
3200182	14	14		3201532	15	5		3230052	10	25	
3200184	13	4		3201533	6	13		3230053	10	27	
3200185	13	5						3230054	10	23	
3200186	13	6		3203000	2	22		3230060	8	17	
3200187	13	7						3230061	8	13	
3200189	13	16		3204020	4	1		3230063	8	15	
3200190	13	17		3204021	10	16		3230064	8	20	
3200191	13	18		3204059	14	13		3230065	8	12	
3200192	13	25		3204060	14	17		3230066	8	3	
3200194	13	21		3204061	14	18		3230067	8	4	
3200196	14	21		3204062	14	24		3230068	9	23	
3200199	14	1		3204063	14	23		3230069	9	27	
3200200	14	3		3204064	14	19		3230070	9	25	
3200201	14	7		3204065	14	11		3230071	8	8	
3200203	14	35		3204066	6	1		3230072	8	1	
3200204	14	40		3204070	7	1		3230074	2	59	
3200205	13	11						3230075	3	14	
3200206	13	15		3210002	1	1		3230076	3	34	
3200207	13	32						3230077	3	37	
3200209	2	24		3230011	4	3		3230078	3	17	
3200210	2	40		3230012	4	5		3230079	6	25	
3200211	14	39		3230013	4	7		3230080	3	48	
3200215	13	26		3230014	4	4		3230082	3	24	
3200216	13	30		3230015	4	6		3230084	3	55	
3200227	15	21		3230020	1	6		3230085	3	49	
3200231	15	39		3230021	1	7		3230086	11	26	
3200232	15	30		3230022	2	9		3230087	11	24	
3200233	15	26		3230023	2	1		3230088	3	45	
3200234	15	23		3230025	2	14		3230090	7	29	
3200235	15	29		3230026	2	4		3230092	3	39	
3200236	15	17		3230027	2	7		3230096	12	22	
3200237	15	16		3230028	2	51		3230097	12	25	

INDEX

VFK2560-8

Page = 6

<u>Parts No.</u>	<u>Page No.</u>	<u>Ref. No.</u>	<u>Weight(g)</u>	<u>Parts No.</u>	<u>Page No.</u>	<u>Ref. No.</u>	<u>Weight(g)</u>	<u>Parts No.</u>	<u>Page No.</u>	<u>Ref. No.</u>	<u>Weight(g)</u>
3230098	6	15		3239300	11	30		9620678	21	35	
3230099	6	14		3239310	12	32		9620679	21	24	
3230100	11	28		3239900	16	1		9620679	21	36	
3230101	10	14		3239901	18	1		9620680	21	25	
3230102	3	41		3239902	17	1		9620680	21	37	
3230103	3	59						9620681	21	26	
3230104	3	47		3500014	1	9		9620681	21	38	
3230105	10	32		3500014	2	32		9620688	21	18	
3230106	3	65		3500014	4	27		9620688	21	33	
3230108	10	17		3500044	4	11		9620689	21	4	
3230109	10	18		3500045	4	12		9620690	21	21	
3230120	5	29		3500047	4	8		9620691	21	20	
				3500048	4	9		9620696	21	1	
3231000	16	2		3500050	4	31		9620700	21	17	
3231003	16	12		3500065	6	21		9620700	21	32	
3231004	16	7		3500066	6	19		9620703	21	16	
3231005	16	6		3500081	11	3		9620703	21	31	
3231006	16	4		3500082	11	4					
3231009	2	43		3500084	11	6					
3231010	17	20		3500086	11	10					
3231050	19	18		3500100	7	2					
3231051	19	16		3500284	3	52					
3231052	19	19		3500285	3	54					
3231053	19	20		3500305	8	35					
3231054	19	21		3500430	1	3					
				3500442	6	31					
3237000	9	1-1		3500446	6	17					
3237001	9	1-2		3500448	6	12					
3237005	9	2-1		3500489	3	51					
3237006	9	2-2		3500492	6	22					
3237010	9	20									
3237011	9	22		3530015	21	40					
3237040	9	10									
3237051	9	17		4109410	1	27					
3237052	9	15									
3237053	9	4		6209401	1	29					
3237054	9	6									
				9603082	20	1					
3238000	7	8-1		9603085	19	15					
3238001	7	8-2									
3238010	17	22-1		9620631	21	2					
3238011	17	22-2		9620650	21	28					
				9620660	21	29					
3239000	14	30		9620666	21	22					
3239001	14	32		9620670	21	3					
3239100	7	4-1		9620673	21	8					
3239101	7	4-2		9620675	21	11					
3239200	5	37		9620678	21	23					



4-4-12,NISHITENMA, KITA-KU, OSAKA,JAPAN
TEL: 81-6-6364-5621 FAX: 81-6-6364-7185

〒530-0047 大阪市北区西天満 4丁目 4番 12号
TEL(06) 6364-5621(代) FAX(06) 6364-7185