



Union Special[®]
INDUSTRIAL SEWING EQUIPMENT

STYLES

ADJUSTING INSTRUCTIONS AND
ILLUSTRATED PARTS LIST

53700B

53800B

STREAMLINED
FIFTY THOUSAND SERIES

CATALOG NO.
100L

SECOND EDITION

MANUAL NO. 100L ADJUSTING INSTRUCTIONS AND ILLUSTRATED PARTS LIST FOR 53700/53800
SERIES MACHINES

Second Edition Copyright 2003
BY
Union Special Corporation Rights Reserved In All Countries
Printed in U.S.A. Nov 2003

FOREWORD

The new streamlined Class 53700 and 53800 machines bring to the automobile upholstery and seat cover industry new styling, improved lubrication, and light running high speed performance. Enclosed type oiling system for looper drive eccentric, upper feed driving eccentric, and needle lever crank have substantially increased the speed of these machines. The almost entirely automatic lubrication system makes maintenance simple. All parts are made by precision methods insuring complete interchangeability.

It is our constant aim to furnish carefully prepared information which will enable our customer to secure all possible economies from the use of Union Special sewing machines. The following pages illustrate and describe the parts for the styles in Classes 53700 and 53800.

Union Special representatives will be found in all manufacturing centers, ready to cooperate with you to plan and estimate requirements.

CONTENTS

IDENTIFICATION OF MACHINE	3
APPLICATION OF CATALOG	3
STYLES OF MACHINE	3
NEEDLES	4
ORDERING REPAIR PARTS	4
ORDERING REPAIR PARTS (CONTINUED)	5
IDENTIFYING PARTS	5
USE GENUINE NEEDLES AND REPAIR PARTS	5
TERMS	5
OILING AND THREADING	5
OILING AND THREADING DIAGRAM	6
SELF-PRIMING HEAD OIL SIPHON	7
INSTALLING AND MAINTENANCE OF OIL SIPHON	7
INSTRUCTIONS FOR MECHANICS	8
NEEDLE LEVER STUD SETTING	8
OILING SYSTEM	8
SETTING THE ZIG-ZAG MOTION	8
SPACING NEEDLE IN THROAT PLATE	8
SETTING THE LOOPER	8
SETTING THE LOOPER (CONTINUED)	9
SETTING HEIGHT OF NEEDLE BAR	9
SYNCHRONIZING LOOPER AND	9
NEEDLE MOTIONS	9
SYNCHRONIZING LOOPER AND	10
NEEDLE MOTIONS (CONTINUED)	10
SETTING THE FEED DOG	10
SETTING THE FEED DOG (CONTINUED)	11
CHANGING STITCH LENGTH	11
SETTING THE NEEDLE GUARD	11
SYNCHRONIZATION OF THE UPPER ROLLER FEED	12
THREADING	12
SETTING THE LOOPER THREAD TAKE-UP	13
THREAD TENSIONS	13
PRESSER FOOT PRESSURE	13
SETTING NEEDLE THREAD TAKE-UP	13
SETTING SPRING RETAINER ON LOOPER	14
THREAD TENSION RELEASE	14
SETTING THE ATTACHMENTS	14
MAIN FRAME, CAST-OFF PLATE, MISCELLANEOUS COVERS AND PLATES	17
CLOTH PLATES, CLOTH PLATE COVERS, MISCELLANEOUS AND ATTACHMENTS	19
MAIN FRAME, BUSHINGS AND MISCELLANEOUS OILING PARTS	21
FOR STYLES 53100B AND C ONLY CLUTCH ASSEMBLY, CLUTCH DRIVE SHAFT GEAR AND HOUSING ASSEMBLY	23
FOR STYLES 53100B AND C ONLY CLUTCH ASSEMBLY, CLUTCH DRIVE SHAFT GEAR AND HOUSING ASSEMBLY	25
CRANKSHAFT, NEEDLE LEVER AND LOOPER DRIVING PARTS	27
CRANKSHAFT, NEEDLE LEVER AND LOOPER DRIVING PARTS	29
LOOPER ROCKER AND CONNECTING ROD PARTS	31
MAIN SHAFT AND FEED MECHANISM	33
FOR STYLE 53100E ONLY MAIN SHAFT AND FEED MECHANISM	35
THREAD TENSION AND FOOT LIFTER LEVER PARTS	37
FEED DOGS, THROAT PLATES AND PRESSER FEET	39
THREAD STAND, KNEE PRESS AND TAPE REEL PARTS	41

IDENTIFICATION OF MACHINE

Each UNION SPECIAL machine is identified by a Style number which is stamped into the name plate on the machine. Style numbers are classified as standard and special. Those which are standard have one or more letters suffixed to the class number, but never contain the letter "Z". Example : "53700B". Style numbers containing the letter "Z" are special. When only minor changes are made in a standard machine, a "Z" is merely suffixed to the standard style number. Example: "53700BZ".

Styles of machines similar in construction are grouped under a class number which differs from the style number, in that it contains no letters. Example: "53700".

APPLICATION OF CATALOG

This catalog applies specifically to the standard Styles of machines as listed herein. It can also be applied with discretion to some Special Styles of machines in this class.

STYLES OF MACHINE IN CLASSES 53700 AND 53800

Streamlined Enclosed Type Flat Bed, High Throw, Power Driven Upper Running Feed, with Alternating Presser Foot Action, Lower Feed, Single Reservoir Enclosed Automatic Lubricating System and Filter Type Oil Return Pump, Lateral Looper Travel, 1 1/2 Inch Needle Travel, Work Space to Right of Needle, 7 3/4 Inches.

53700B For seaming operations on automobile upholstery and similar articles made from medium heavy to heavy weight materials, one needle machine, four to seven stitches per inch, seam specification 401-SSa-1. Maximum recommended speed 3300 R.P.M.

53800B For seaming operations on automobile upholstery, also on fiber, fabric, and plastic automobile seat covers and for similar operations on medium heavy to heavy weight materials with or without corded leatherette or plastic piping, two needle machine, four to seven stitches per inch, seam specification 401-SSa-2. Maximum recommended speed 3300 R.P.M.

NEEDLES

Each UNION SPECIAL needle has both a type number and a size number. The type number denotes the kind of shank, point, length, groove, finish and other details. The size number, stamped on the needle shank, denotes the largest diameter of blade measured in thousandths of an inch midway between the shank and the eye. Collectively, type number and the size number is the complete symbol.

Standard needle for Styles 53700 B, and 53800B is Type 147 GS. It is a round shank, round point, long, double groove, ball eye, spotted, short point, struck groove, undersize eye and grooves, one step reduction, chromium plated needle and is available in sizes 080/032, 090/036, 100/040, 110/044, 125/049, 140/054, 150/060, 170/067.

Also available for styles 53700B and 53800B is Type 143GS. It is a round shank, round point, No. 2 bag, double groove, spotted, chromium plated needle and is available in sizes 140/054, 150/060, 170/067.

To have needle orders promptly and accurately filled, an empty package, a sample needle, or the type and size number should be forwarded. Use description on label. A complete order would read: "11000 Needles, Type 147 GS, Size 140/054".

Selection of the proper needle size should be determined by the size of thread used. Thread should pass freely through needle eye in order to produce a good stitch formation.

ORDERING REPAIR PARTS

ILLUSTRATIONS

This catalog has been arranged to simplify ordering repair parts. Exploded views of various sections of the mechanism are shown so that the parts may be seen in their actual position in the machine. On the page opposite the illustration will be found a listing of the parts with their part numbers, descriptions and the number of pieces required in the particular view being shown.

Numbers in the first column are reference numbers only and merely indicate the position of that part in the illustration. Reference numbers should never be used in ordering parts. Always use the part number listed in the second column.

Component parts of sub-assemblies which can be furnished for repairs are indicated by indenting their descriptions under the description of the main subassembly. Example:

23.	29105Q	Looper Drive Eccentric Assembly	1
24.	22559B	Bearing Cap Screw, upper	2
25.	22894D	Eccentric Spot Screw	1
26.	22894C	Eccentric Set Screw	1
27.	22559A	Bearing Cap Screw, lower	2

It will be noted in the above example that the eccentric and bearing are not listed. The reason is that replacement of these parts individually is not recommended, so the complete sub-assembly should be ordered.

In those cases where a parts for the class 53700B and 53800B are not the same the difference will be shown in the illustrations and descriptions. When a part is used in all machines covered in this catalog no machine style is mentioned.

At the back of the book will be found a numerical index of all the parts shown in this book. This will facilitate locating the illustration and description when only the part number is known.

IDENTIFYING PARTS

Where the construction permits, each part is stamped with its part number. On some of the smaller parts, and on those where the construction does not permit, an identification letter is stamped in to distinguish the part from similar ones.

Part numbers represent the same part, regardless of catalog in which they appear.

IMPORTANT! ON ALL ORDERS, PLEASE INCLUDE PART NAME AND STYLE OF MACHINE FOR WHICH PART IS ORDERED.

USE GENUINE NEEDLES AND REPAIR PARTS

Success in the operation of these machines can be secured only with genuine UNION SPECIAL Needles and Repair Parts as furnished by the Union Special Corporation, its subsidiaries and authorized distributors. They are designed according to the most approved scientific principles, and are made with the utmost precision. Maximum efficiency and durability are assured.

Genuine needles are packaged with labels marked **Union Special** Genuine repair parts are stamped with the Union Special trademark, U S Emblem. Each trademark is your guarantee of the highest quality in materials and workmanship.

TERMS

Prices are strictly net cash and are subject to change without notice. All shipments are forwarded f.o.b. shipping point. Parcel Post shipments are insured unless otherwise directed. A charge is made to cover the postage and insurance.

OILING AND THREADING

The oil has been drained from the machine before shipping, and the reservoir must be filled before beginning to operate. Use a straight mineral oil with a Saybolt viscosity of 90 to 125 seconds at 1000 Fahrenheit.

Oil is filled at the spring cap in the top cover, and the oil level is checked at the sight gauge on the front of the machine. The oil level should be maintained between the red lines on the gauge. The capacity of the oil reservoir is 12 ounces.

The lubrication, which is almost entirely automatic, requires a minimum of manual oiling. The oiling diagram on the opposite page is self-explanatory.

The main reservoir supplies oil to the looper drive eccentric, upper running feed drive eccentric, needle lever crank: and the supply is registered at the front gauge. The entire lower mechanism is served through a system of channels and wicks in the main frame by this reservoir.

A daily check before the morning start should be made and oil added if required. Oil which has gone through the machine is filtered and pumped back into the main reservoir, making too frequent oilings unnecessary. Excessive oil in the main reservoir may be drained at the plug screw in the main frame directly under the handwheel.

The accompanying diagram also shows the threading of the single needle Class 53700B machine. Threading of the two needle Class 53800B machine is substantially the same.

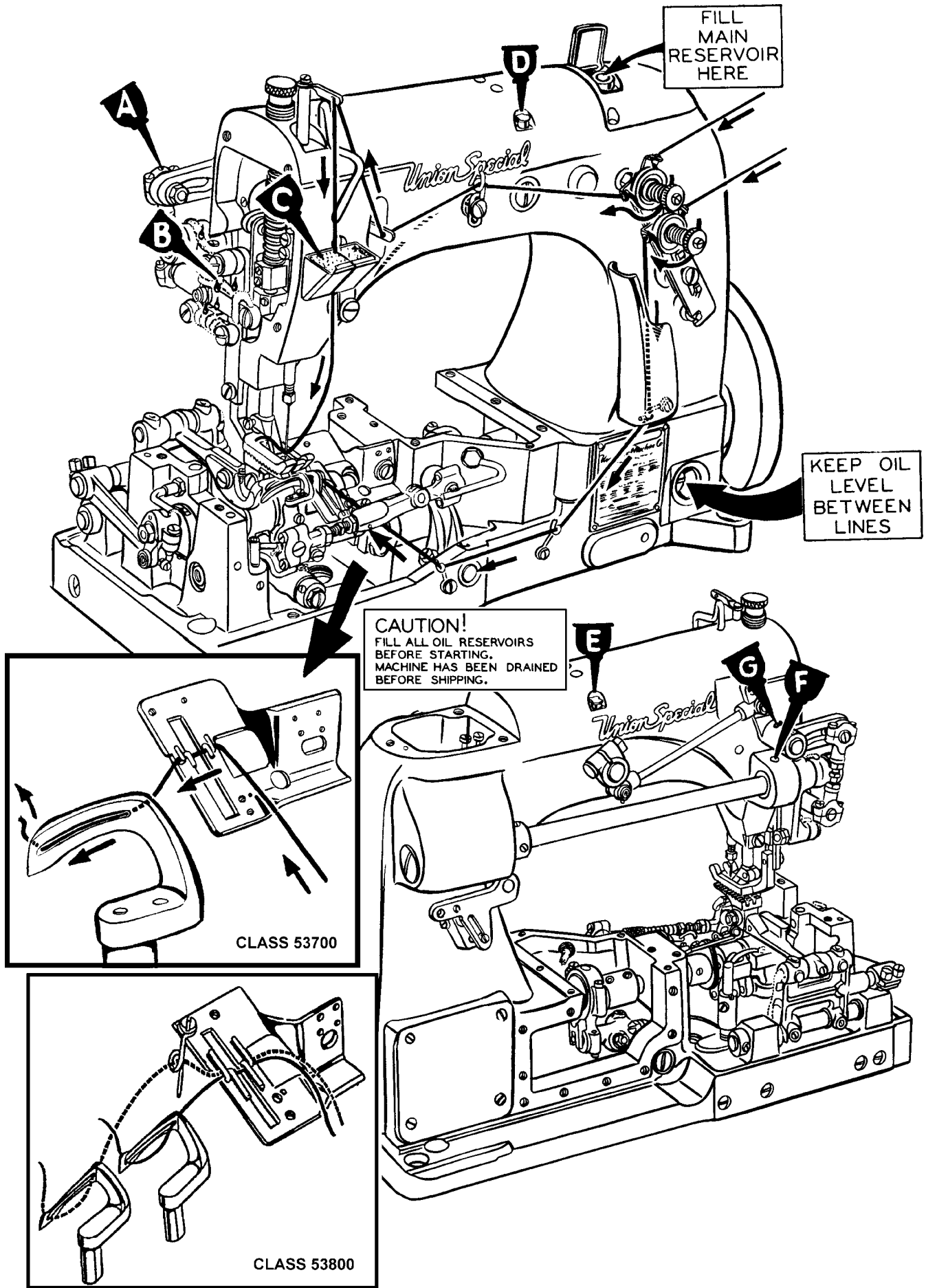

Fig. 1

SYNCHRONIZING LOOPER AND NEEDLE MOTIONS

Check the synchronization of the looper and needle motions, using gauge No. T34 and plate No. 21227AD as follows:

Insert the pin, which is included with the gauge, in the looper rocker for 2 needle machine use right looper. Place the gauge plate on the throat plate seat using the throatplate screws for attaching. Place the indicator portion of the gauge in the needle thread take-up wire hole with the pointer to the right, but do not tighten the set screw at this time. Turn the handwheel in the operating direction until the pin in the looper rocker contacts the edge of the gauge plate and set the indicator so that the left end of the pointer rests against the top of the needle bar and the right end of the pointer rests at "0". Tighten the set screw and note indicator reading. Turn the handwheel in the reverse direction until the pin again contacts the plate. If the motions are in synchronization, the pointer of the indicator will return to the same reading. A variation of one graduation on the scale is allowable. If the reading is higher on the scale when the handwheel is turned in the operating direction, the looper drive lever rocker will have to be moved to the rear. If the reading is lower, the rocker will have to be moved to the front.

NOTE: If gauge No. 21227AD is not available, synchronization may be checked as follows:

Insert the looper in the looper rocker and turn the handwheel in the operating direction until the point of the looper, moving to the left, is even with the left side of the needle. Note the height of the eye of the needle with respect to the looper point, then turn handwheel in the reverse direction until the looper point again moves to the left and is even with the left side of the needle. If the motions synchronize, the height of the eye of the needle with respect to the looper point will be the same. A variation of .005 inch is allowable. If the distance from the eye of the needle to the point of the looper is greater when the handwheel is turned in the operating direction, move the looper drive lever rocker to the rear. Moving it in the opposite direction acts the reverse. Moving of the looper drive lever rocker is accomplished as follows:

Remove the cloth plate, throat plate support, oil reservoir top cover and loosen the screws in the looper drive eccentric mechanism and move the eccentric as far to the right as it will go. Drive the rear bushing to the front or the middle bushing to the rear, as required. CAUTION: To avoid distorting the parts, remove the plug screw in the bed behind the rear bushing before driving to the front and place a horse shoe shaped metal washer approximately 1/16 inch thick between the looper drive lever and adjacent bushing when driving the bushing to the rear. Correctly reposition the looper drive eccentric mechanism (per spot screws) and tighten all screws securely.

SETTING THE LOOPER

Insert a new needle, type and size as specified, with spot or scarf to the rear. With the looper (A, Fig. 2) at its farthest position to the right, its point should be $\frac{5}{32}$ inch from the centerline of the needle. If adjustment is required, loosen nut (B) (it has a left hand thread) and nut (C) on connecting rod (D) and turn the connecting rod forward or backward to obtain the $\frac{5}{32}$ inch dimension (Fig. 2). Looper gauge No. 21225-5/32 can be used advantageously in making this adjustment. Retighten both nuts, first nut (C), then nut (B). Make sure the left ball joint is in vertical position and does not bind after adjustment.

NOTE: For 2 needle 53800, looper gauge should be set using the right needle and looper.

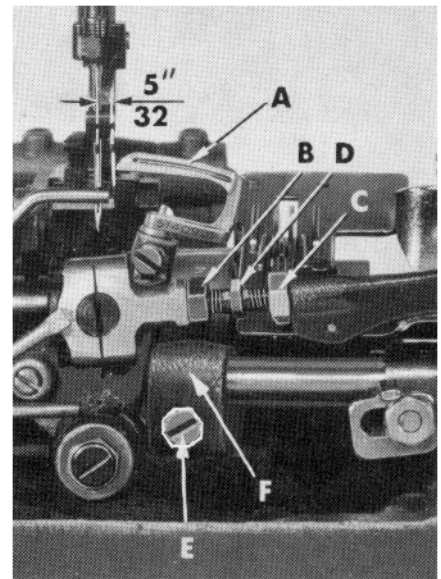

Fig. 2

SETTING THE LOOPER (CONTINUED)

The looper is set correctly front to back, as it moves to the left behind the needle, when its point passes as close as possible without contacting the needle (.001-.002). If adjustment is necessary, loosen screw (E, Fig. 2) in looper rock shaft arm (F), reposition looper as required and retighten screw (E).

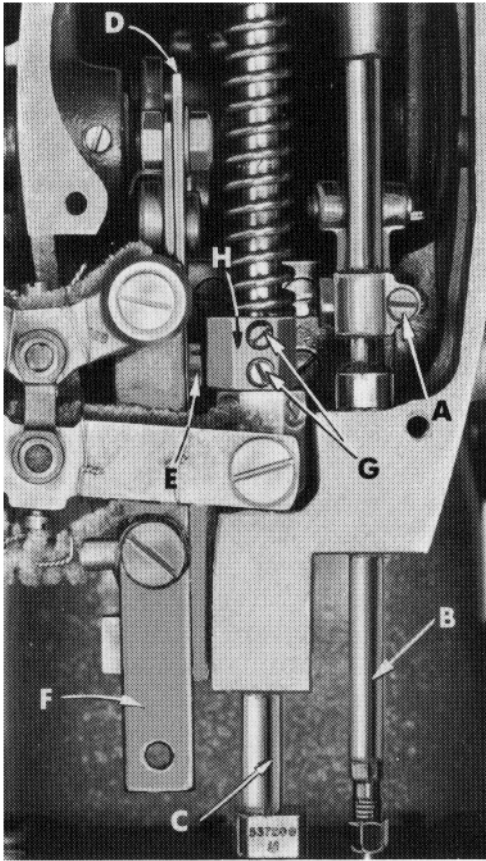

Fig. 3

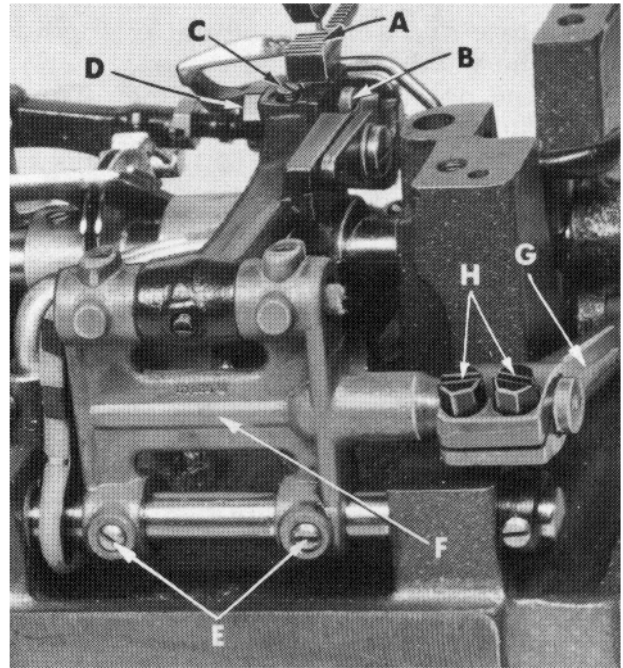

Fig. 4

SETTING HEIGHT OF NEEDLE BAR

The height of the needle is correct when the top of its eye is 1/64 inch below the underside of the looper, when the looper point is flush with the left side of the needle. If adjustment is necessary, loosen screw (A, Fig. 3) and move needle bar (B) up or down as required and retighten screw (A).

SETTING THE FEED DOG

Set the feed dog (A, Fig. 4) in the throat plate so there is equal clearance on all sides. See that the tips of the teeth extend 1/2 to 1 full tooth above the throat plate and are parallel with the throat plate at high point of travel. Height can be set by loosening feed dog attaching screw (B) and adjusting feed dog supporting screw (C). Parallelism can be set by loosening nut (D) and rotating feed dog holder adjusting screw (A, Fig. 5), as required and retighten nut. Side clearance can be set by loosening screws (E, Fig. 4) and moving feed rocker (F) to the right or left, as required.

NOTE: Whenever the feed rocker has been moved, always check to assure that the feed rocker arm (G) does not bind.

End clearance can be set by loosening screws (H) in the feed rocker arm (G) and moving feed rocker (F) forward or backward as required.

INITIAL SETTINGS OF UPPER RUNNING FEED MECHANISM

The top feed eccentric assembly should be located on the main shaft so that the first screw in the eccentric will be in a perpendicular position to the mainshaft when the needle bar has risen 1/4 inch from the bottom of its stroke, with the handwheel turned in the operating direction.

NOTE: Eccentric may need to be advanced or retarded to obtain proper feeding between top and bottom feeds.

NOTE: The next two paragraphs refer to the maximum height setting of the top feed mechanism which can be lowered later to suit sewing conditions.

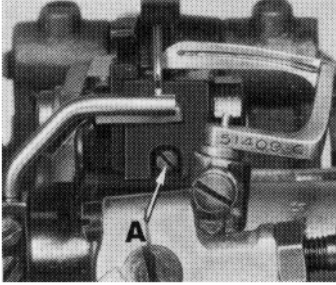

Fig. 5

Turn handwheel in the operating direction until the needle bar is at the bottom of its stroke. Loosen nut (B, Fig.6), and move upper feed lift driving lever (A) so that the teeth of the upper feed dog is 5/32" (7.9mm) for style 53700B and 3/16" to 13/64" (4.8 to 5.2mm) for style 53800B, above the top of

the throat plate. Then tighten nut (B) securely.

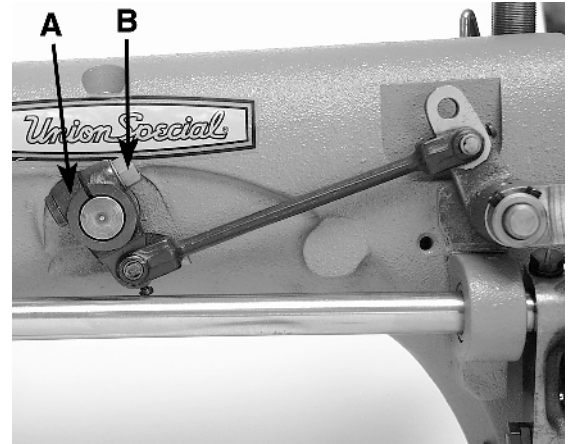

Fig. 6

The bell crank lever ball joint (A, Fig. 7) should be in the center of the upper feed bell crank lever (B). The ball joint may need to be moved slightly to meet sewing conditions.

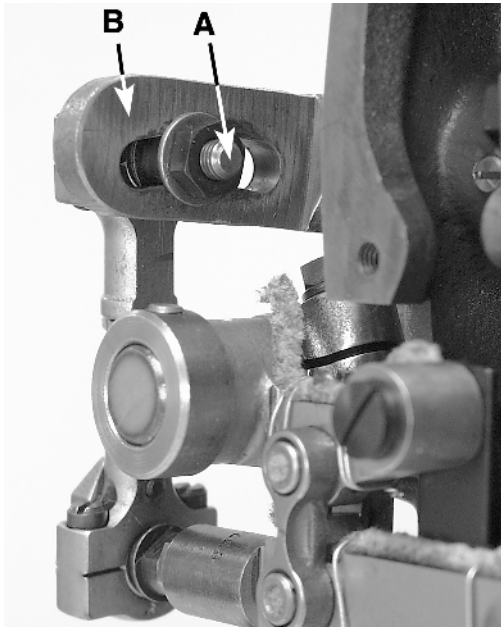

Fig. 7

As the needle bar just begins to rise from the bottom of its stroke, the distance between the rear of the needle bar (A, Fig.8) and the front of the upper feed bar (B) should be 1 3/32 inch (Fig. 8). Adjustment can be made by loosening screw (C) in the upper feed driving lever (D) and moving it forward or rearward as required and retighten screw (C).

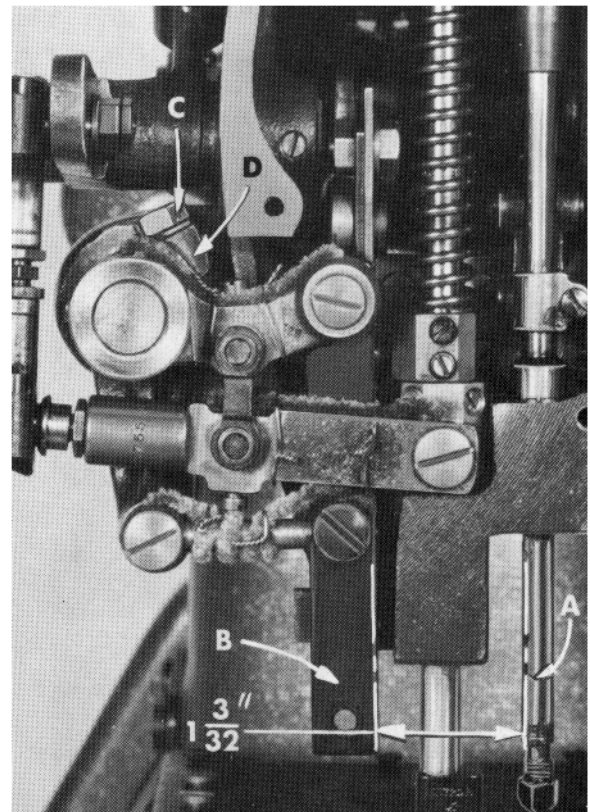

Fig. 8

INITIAL SETTINGS OF UPPER RUNNING FEED MECHANISM (CONTINUED)

Synchronizing the upper feed with the lower feed can be accomplished by loosening nut (A, Fig. 9) and moving the ball stud in the upper feed driving shaft segment lever (B). Retighten nut.

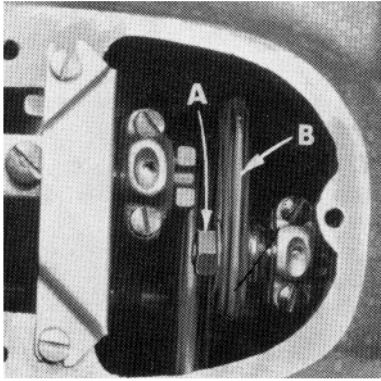

Fig. 9

CHANGING STITCH LENGTH

Set the stitch to the required length. This is accomplished by loosening locknut (A, Fig. 10) (it has a left hand thread) and turning the stitch adjusting screw (B). Turning screw (B) clockwise shortens the stitch and turning it in a counterclockwise direction lengthens the stitch.

NOTE: Any change in stitch length will necessitate a corresponding change in the rear needle guard setting and also synchronization of the upper running feed mechanism as described previously.

SETTING THE REAR NEEDLE GUARD

Set the rear needle guard (A, Fig. 11) horizontally so that it barely contact the rear of the needle (B) when at its most forward point of travel. It should be set as low as possible, yet have its guarding surface in contact with the needle, until the point of the looper (C), moving to the left, is even with the needle. To move needle guard forward or backward, merely loosen screw (D), move needle guard as required and retighten screw (D). To raise or lower the needle guard, loosen screw (D); and turn screw (E) clockwise to lower or counterclockwise to raise. Retighten screw (D) after guard is properly set.

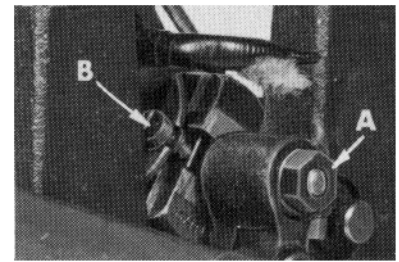

Fig. 10

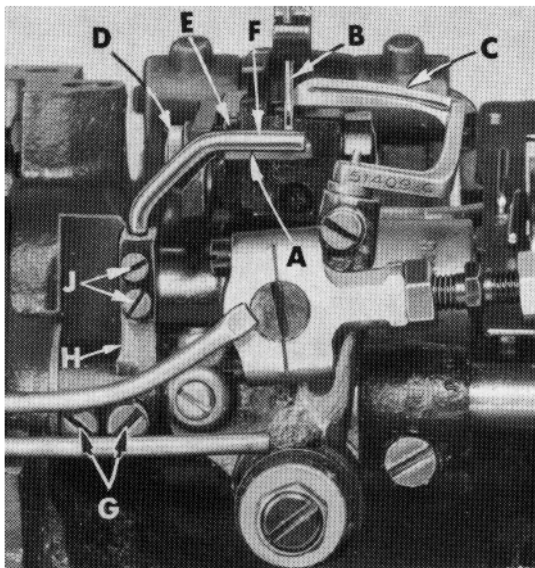

Fig. 11

SETTING FRONT NEEDLE GUARD

Set the front needle guard (F, Fig. 11) so that it barely contacts the needle (B) until the point of the looper (C), moving to the left, is just past the left side of the needle. The looper may brush, but not pick at the needle. The front needle guard should be set as low as possible to meet this condition yet not contact the rear needle guard or looper at any time. To move needle guard forward or rearward, loosen screws (G), rotate needle guard holder (H) as required and retighten screws (G). To raise, lower or rotate needle guard, loosen screws (J), reposition as necessary and retighten screws after guard is properly set.

THREAD TENSION RELEASE

The thread tension release is set correctly when it begins to function as the presser foot is raised to within 1/8 inch of the end of its travel and is entirely released when the presser foot has reached its highest position.

THREAD TENSION RELEASE (CONTINUED)

If adjustment is needed, loosen tension release lever screw (A, Fig. 12), located at the back of the machine and move tension disc separator as required. Retighten screw. After adjustment there should be no binding at any point.

SETTING HEIGHT OF PRESSER BAR

The height of the presser bar (C, Fig. 3) is set correctly if it is possible to remove the presser foot when the foot lifter lever (B, Fig. 12) is fully depressed.

If adjustment is necessary, turn handwheel in operating direction until the needle bar is in the low position. Loosen screws (G, Fig. 3), then, while holding presser foot down on the throat plate surface, pry up presser bar connection and guide (H) with a screwdriver to obtain the 1/16 inch setting and retighten screws.

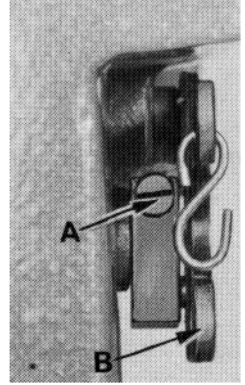

Fig. 12

THREADING

Draw the looper and needle threads into the machine and start operating on a piece of fabric. Refer to threading diagram (Fig. 1) for manner of threading these machines.

SETTING NEEDLE THREAD TAKE-UP WIRE AND FRAME EYELET

Set the needle thread take-up wire (A, Fig. 13) so that its upper surface is even with the top of the hole in the needle bar thread eyelet (B) when the needle bar is at the bottom of its stroke. Lower this setting for a smaller needle thread loop or raise it for a larger loop.

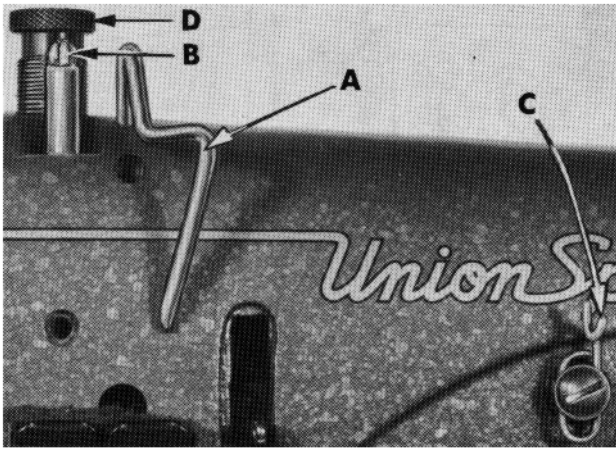

Fig. 13

Set the needle thread frame eyelet (C, Fig. 13) perpendicular to the machine base and 1/4" above the mounting screw. Lower if more needle thread is desired in the stitch or raise for less.

SETTING LOOPER THREAD TAKE-UP

The looper thread retainer finger (A, Fig. 14) should be set so that the looper thread is cast-off just after the eye of the needle comes up out of the material. Coordinated positioning can be acquired by loosening screws (B and C). After looper thread retainer finger has been properly set, retighten screws.

PRESSER FOOT PRESSURE

Regulate the presser spring regulating screw (D, Fig. 13) so that it exerts only enough pressure on the presser foot to feed the work uniformly when a slight tension is placed on the fabric. Turning it clockwise increases the pressure, counter-clockwise acts the reverse.

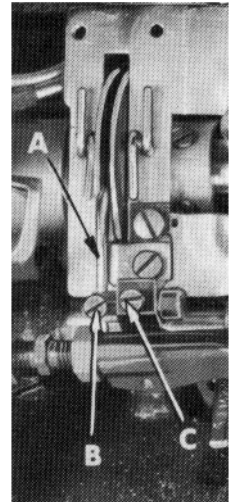
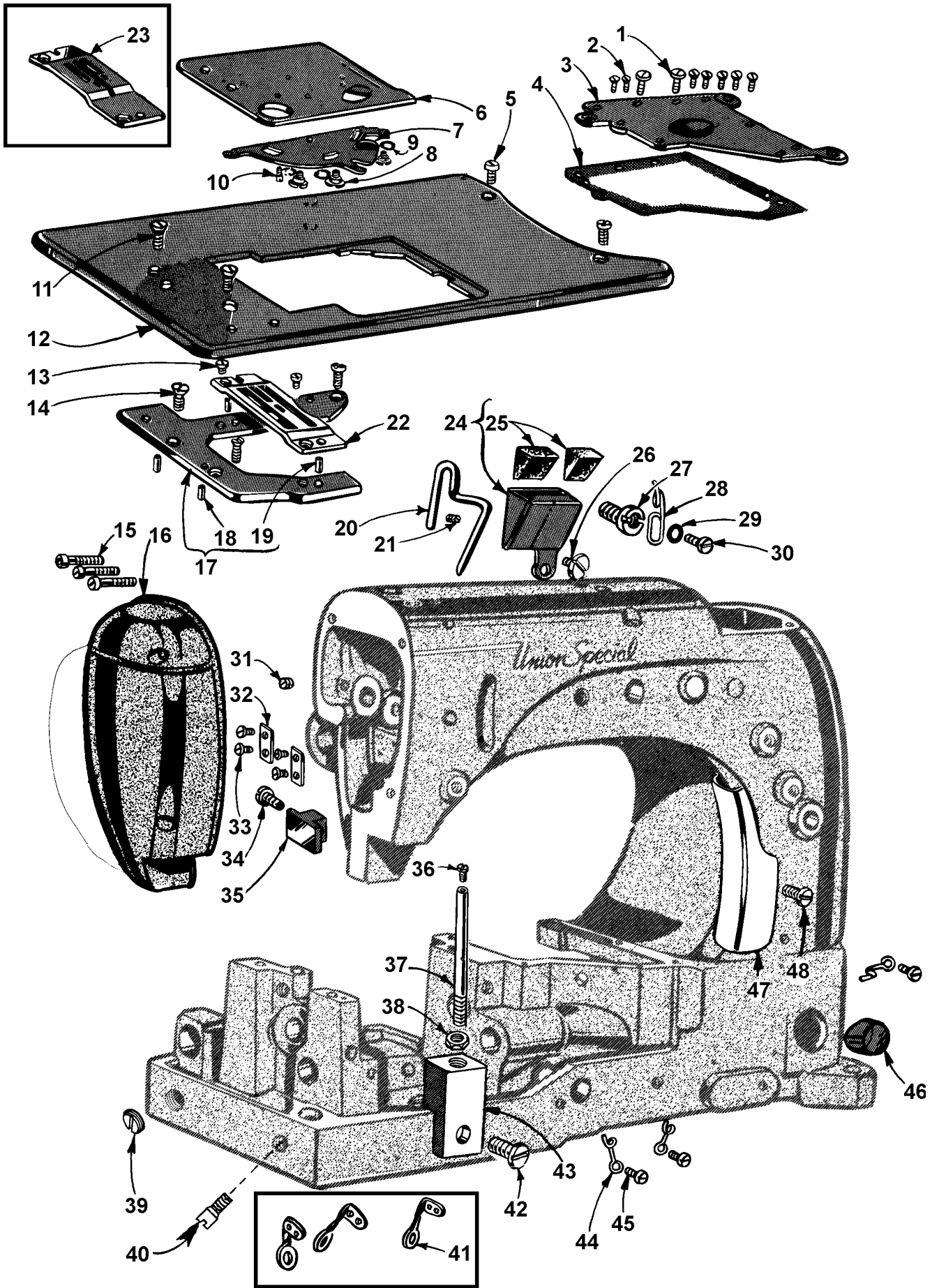

Fig. 14

EXPLODED VIEWS
AND
DESCRIPTION OF PARTS



MAIN FRAME, MISCELLANEOUS COVERS AND PLATES

Ref. No.	Part No.	Description	Amt. Req.
1.	22585A	Screw	2
2.	22524	Screw	7
3.	53782B	Oil Reservoir Top Cover	1
4.	51382B	Gasket	1
5.	22839C	Screw	2
6.	51281P207	Cloth Plate Cover	1
7.	51281AC	Cloth Plate Cover Spring	1
8.	22760A	Screw	3
9.	35772H	Spring Washer	3
10.	22845B	Screw	1
11.	80	Screw	3
12.	53701	Cloth Plate	1
13.	22570	Screw	2
14.	22839	Screw	3
15.	294	Screw	3
16.	53782E	Head Cover	1
17.	53780	Throat Plate Support	1
18.	51280J	Dowel Pin, lower	2
19.	51280K	Dowel Pin, upper	2
20.	51270B	Needle Thread Pull-off Wire	1
21.	95	Screw	1
22.	53724A	Throat Plate, for Style 53700B	1
23.	53824A18	Throat Plate, for Style 53800B	1
24.	21396BN	Needle Thread Lubricator	1
25.	21396AG	Lubricating Felt	2
26.	22517B	Screw	1
27.	22889A	Adapter Screw	1
28.	53758	Frame Thread Eyelet	1
29.	20	Washer	1
30.	22848	Screw	1
31.	95	Set Screw, for upper feed bell crank lever shaft	1
32.	35731A	Presser Bar Connection Guide Plate	2
33.	22513D	Screw	4
34.	22528	Screw	1
35.	53753G	Thrust Bracket	1
36.	605A	Screw	1
37.	53780A	Throat Plate Support Rod	1
38.	12934A	Nut	1
39.	22539H	Plug Screw	1
40.	22889D	Plug Screw	1
41.	158B	Frame Thread Eyelet for Style 53800B	3
42.	136	Screw	1
43.	53780B	Throat Plate Support Rod Bracket	1
44.	52A	Frame Thread Eyelet, for Style 53700B	3
45.	98A	Screw	3
46.	50-648BLK	Lucite Oil Gauge	1
47.	51291A	Looper Thread Guard	1
48.	98A	Screw, for looper thread guard	1
*	20	Washer, for 22848	3
*	22848	Screw, for 51282AH	3

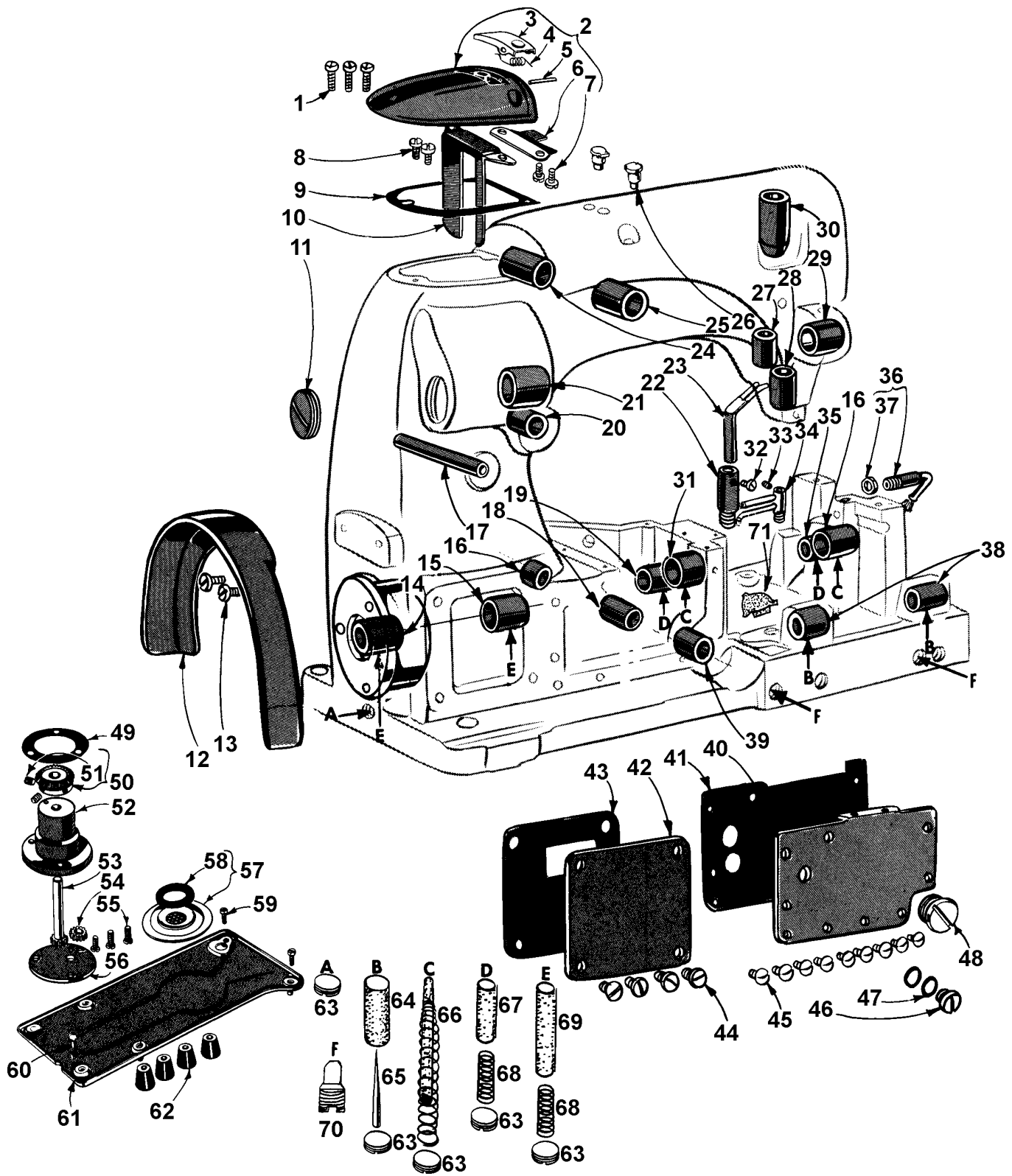

BUSHINGS, OIL TUBES, WICKS AND MISCELLANEOUS COVERS

Ref. No.	Part No.	Description	Amt. Req.
1.	22541B	Screw	3
2.	52882AD	Crank Chamber Cover, upper	1
3.	39582L	Oil Cap	1
4.	52882AC	Oil Cap Torsion Spring	1
5.	50-789BLK	Oil Cap Hinge Pin	1
6.	52882AA	Drip Plate	1
7.	90	Screw	2
8.	90	Screw	2
9.	52882P	Gasket	1
10.	52882Y	Baffle Plate	1
11.	22539D	Plug Screw	1
12.	21375BQ	Belt Guard	1
13.	93	Screw	2
14.	52891B	Main Shaft Bushing Housing, includes bushing	1
15.	52890C	Main Shaft Bushing, left and right	2
16.	51242C	Looper Drive Lever Shaft Bushing, front	1
17.	21657X	Tension Release Lever Shaft Bushing	1
18.	51242R	Looper Drive Lever Shaft Bushing, middle	1
19.	52944U	Looper Rock Shaft Bushing, right	1
20.	52883R	Presser Foot Lifter Lever Bushing	1
21.	53790A	Upper Running Feed Drive Rock Shaft Bushing, right	1
22.	52894AB	Oil Tube Holder	1
23.	52894AC	Oil Tube, for feed lift and looper avoid eccentric	1
24.	53750A	Needle Lever Bushing, front	1
25.	53750B	Needle Lever Bushing, rear	1
26.	80689D	Oil Cup	2
27.	51254D	Needle Bar Bushing, lower	1
28.	53788A	Presser Bar Bushing, lower	1
29.	52890C	Upper Running Feed Drive Rock Shaft Bushing, left	1
30.	51254C	Needle Bar Bushing, upper	1
31.	51290T	Main Shaft Bushing, middle	1
32.	90	Screw	1
33.	22560B	Screw	1
34.	52894AK	Oil Tube, for looper rocker and left ball joint	1
35.	52944T	Looper Rock Shaft Bushing, left	1

36. thru 71. See Following page

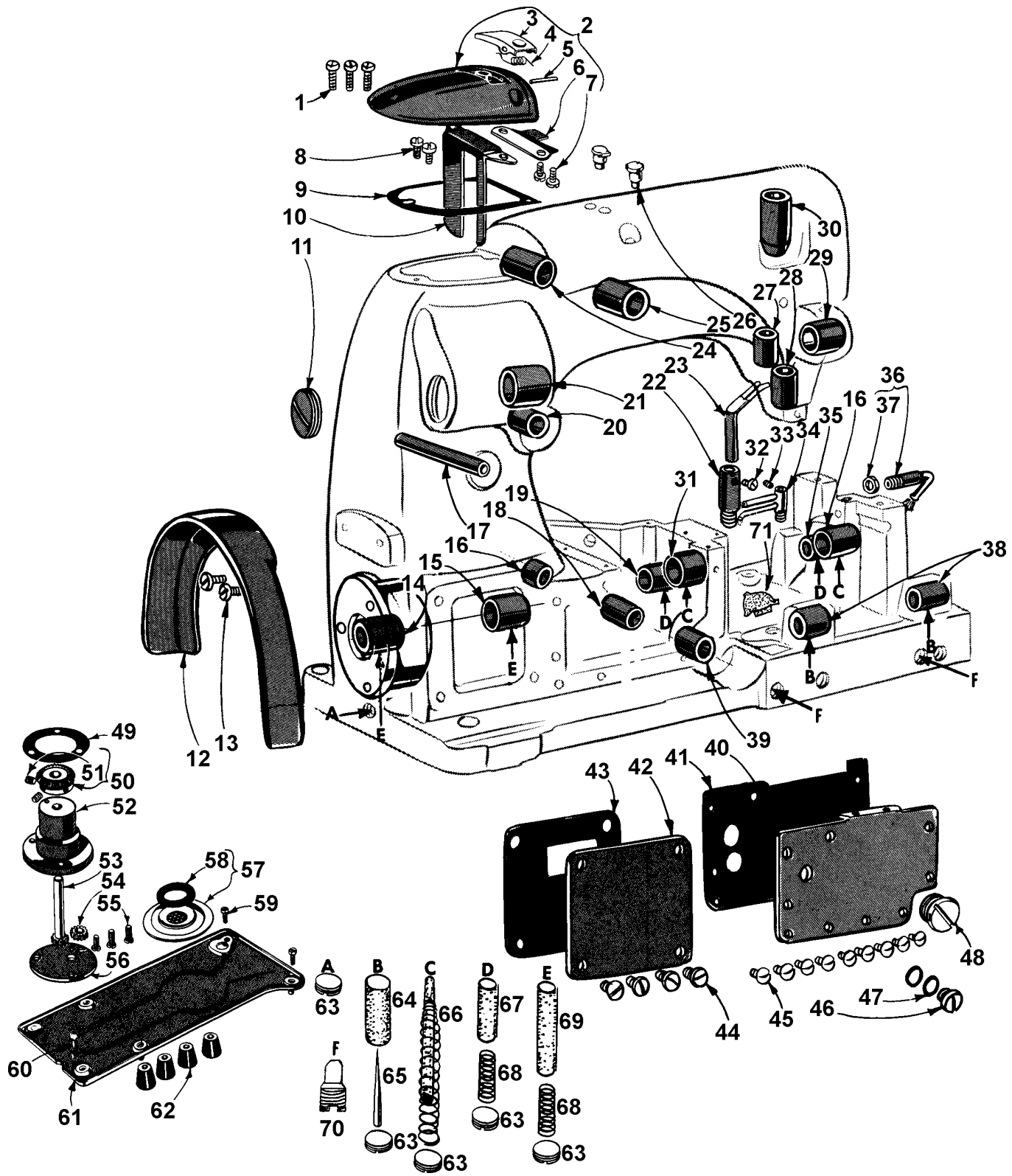

BUSHINGS, OIL TUBES, WICKS AND MISCELLANEOUS COVERS CONTINUED

Ref.			Amt.
No.	Part No.	Description	Req.
1. thru 35. See Previous page			
36.	660-136	Feed Crank Link Oil Tube	1
37.	258A	Nut	1
38.	52936	Feed Rocker Shaft Bushing	2
39.	51242S	Looper Drive Lever Shaft Bushing, rear	1
40.	52882L	Oil Reservoir Back Cover	1
41.	52882AT	Gasket	1
42.	52882AE	Crank Chamber Cover, lower	1
43.	52882AS	Gasket	1
44.	22548	Screw	4
45.	22848	Screw	9
46.	22733B	Screw	1
47.	41394A	Gasket	2
48.	22883A	Plug Screw	1
49.	643-127BLK	Gasket	1
50.	51493BQ	Oil Pump Driven Gear	1
51.	531	Screw	2
52.	51493AG	Oil Pump Housing	1
53.	51493D	Oil Pump Driving Shaft	1
54.	51493BR	Oil Pump Driving Shaft Gear	2
55.	22569B	Screw	3
56.	51493AH	Oil Pump Housing Cover	1
57.	51493BH	Filter Cap Assembly	1
58.	51493BJ	Washer, rubber	1
59.	22823A	Screw	2
60.	22823B	Screw	1
61.	51493AY	Base Plate	1
62.	51295A	Mounting Isolator	4
63.	22571A	Plug Screw	15
64.	666-111	Oil Wick	2
65.	666-179	Wedge Pin	2
66.	666-118	Oil Wick	2
67.	666-65	Oil Wick	2
68.	35178D	Spring	4
69.	666-114	Oil Wick	2
70.	22889C	Plug Screw	2
71.	51493BK	Lint Filter Screen	1
*	22848	Screw, for 51282AH	2
*	51282AH	Oil Shield, end and back	1
*	20	Washer	2

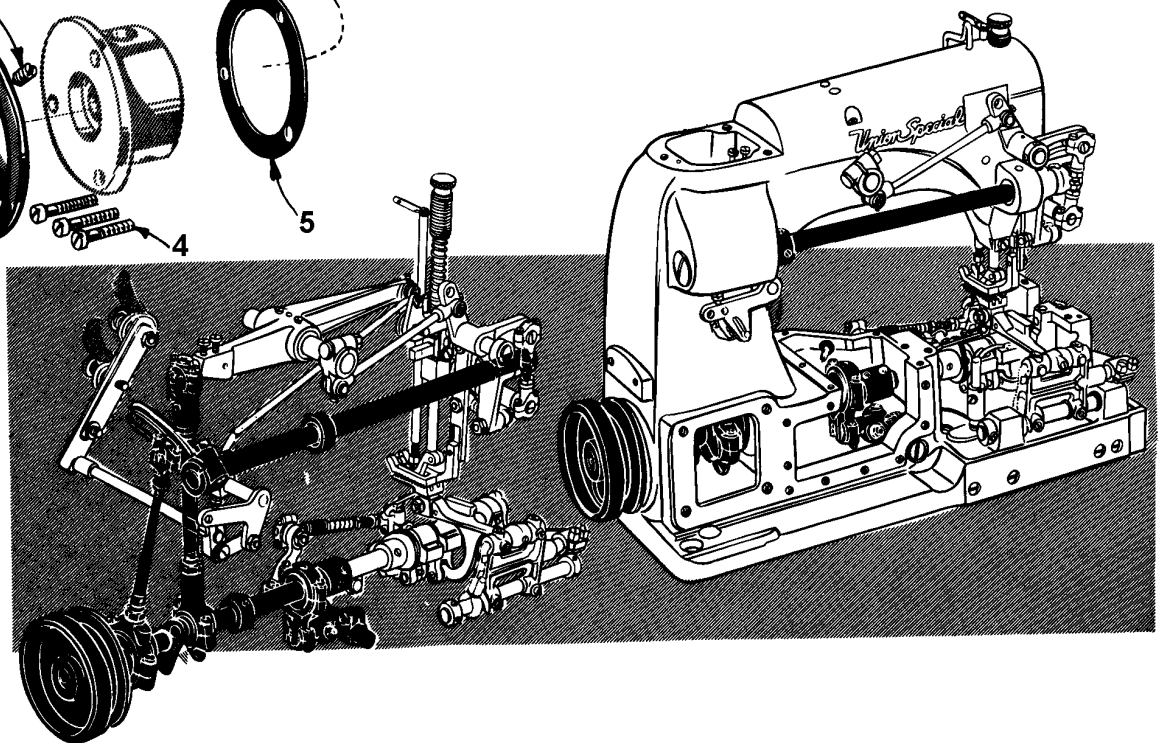
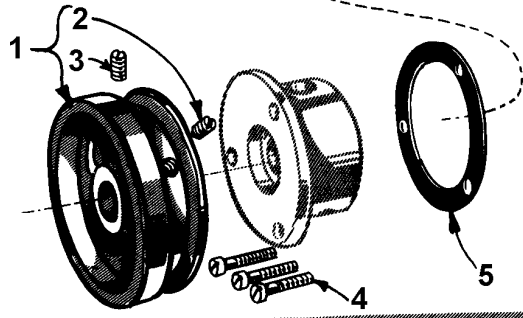
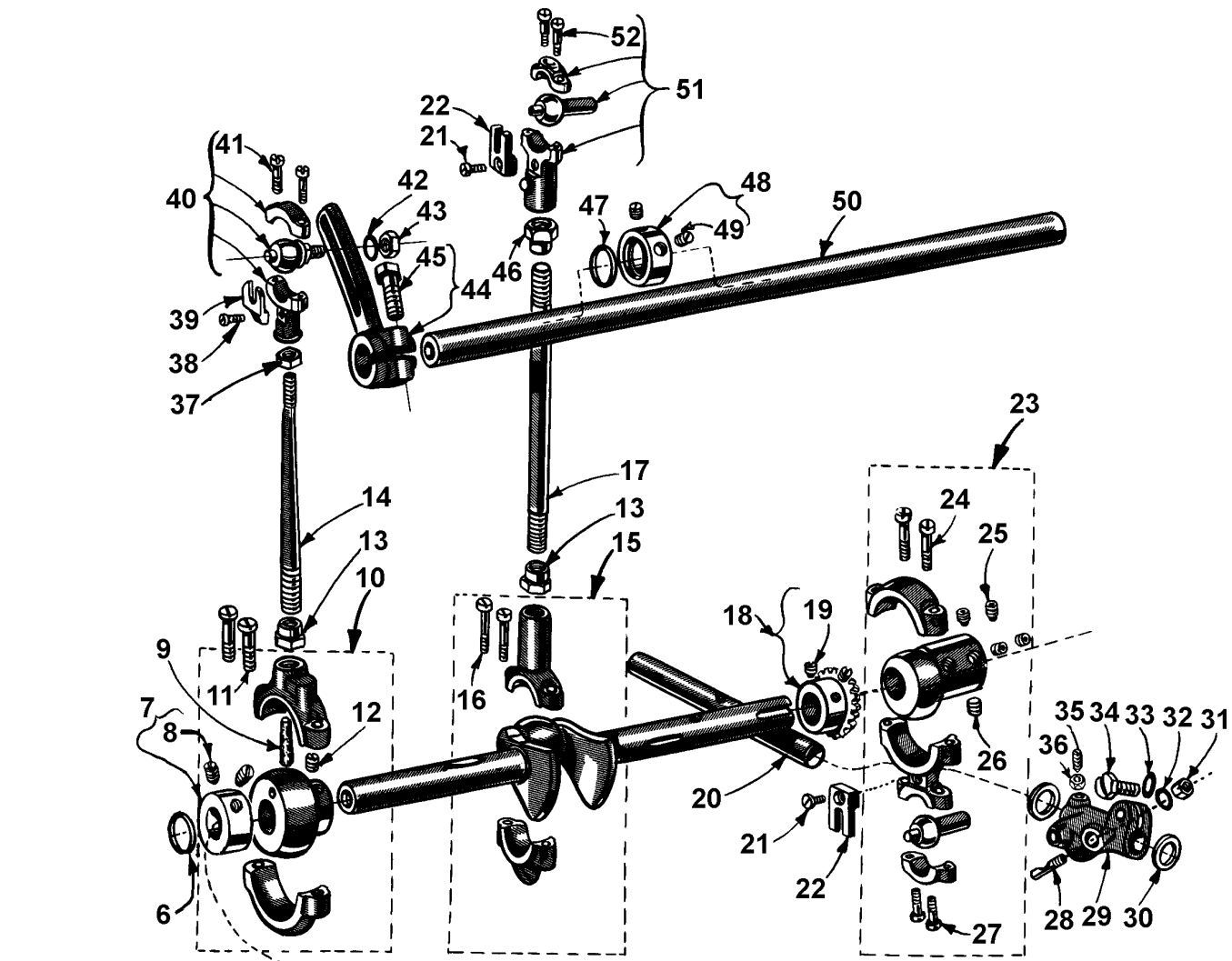

CRANKSHAFT AND UPPER FEED DRIVING ROCK SHAFT PARTS

Ref. No.	Part No.	Description	Amt. Req.
1.	51321G	"V" Belt Handwheel	1
2.	22894H	Spot Screw, for round and "V" belt handwheel	1
3.	22894E	Set Screw, for round and "V" belt handwheel	1
4.	22569B	Screw, for housing	3
5.	56390E	Crankshaft Bearing Housing Gasket	1
6.	660-202	"O" Ring, for pulley	1
7.	9660B	Crankshaft Thrust Collar	1
8.	98	Set Screw	2
9.	666-53	Lubricating Felt	1
10.	29126BJ	Upper Running Feed Drive Eccentric Assembly	1
11.	22587	Bearing Cap Screw	2
12.	22894C	Eccentric Set Screw	2
13.	15430D	Nut, right thread	2
14.	53716	Top Feed Driving Connecting Rod	1
15.	29476DT	Crankshaft Assembly	1
16.	22559E	Bearing Cap Screw	2
17.	51216	Needle Lever Connecting Rod	1
18.	51493BP	Pump Driving Gear	1
19.	22560B	Screw	2
20.	51242P	Looper Drive Lever Shaft	1
21.	22729	Screw	2
22.	51243C	Ball Stud Guide Fork	2
23.	29105Q	Looper Drive Eccentric Assembly	1
24.	22559B	Bearing Cap Screw, upper	2
25.	22894D	Eccentric Spot Screw	2
26.	22894C	Eccentric Set Screw	3
27.	22559A	Bearing Cap Screw, lower	2
28.	52841G	Locking Stud	1
29.	51242Y	Looper Drive Lever Rocker	1
30.	51242L	Thrust Washer	2
31.	52841J	Nut	1
32.	51242M	Washer	1
33.	51242M	Washer	1
34.	22852A	Clamp Screw	1
35.	81	Spot Screw	1
36.	12982	Lock Nut	1
37.	269	Nut, left thread	1
38.	22747	Screw	1
39.	41255B	Ball Stud Guide Fork	1
40.	52854	Upper Running Feed Drive Connecting Rod Ball Joint Assembly	1
41.	22729C	Bearing Cap Screw	2
42.	454A	Washer	1
43.	258	Nut	1
44.	53752	Upper Feed Driving Shaft Segment Lever	1
45.	22811	Clamp Screw	1
46.	80630C	Nut, left thread	1
47.	660-202	Oil Seal Ring	1
48.	52849C	Upper Running Feed Drive Rock Shaft Thrust Collar	1
49.	95	Set Screw	2
50.	52849	Upper Running Feed Drive Rock Shaft	1
51.	29066X	Needle Lever Connecting Rod Ball Joint	1
52.	97A	Bearing Cap Screw	2

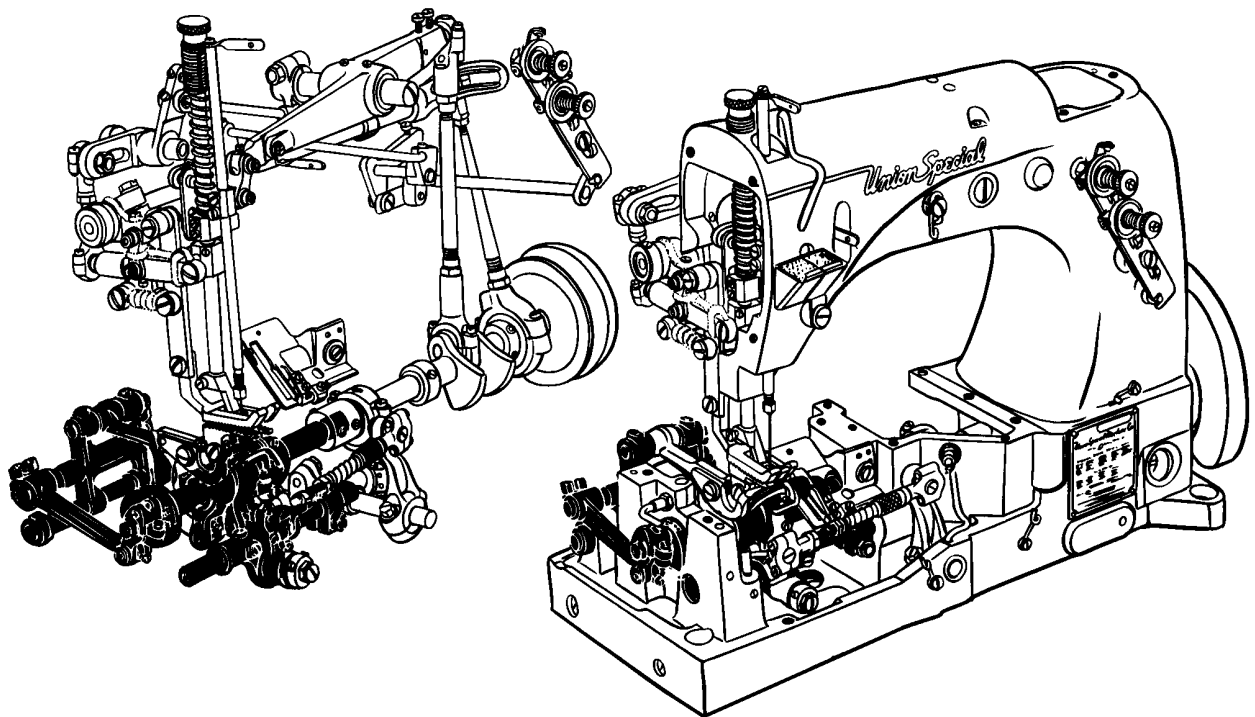
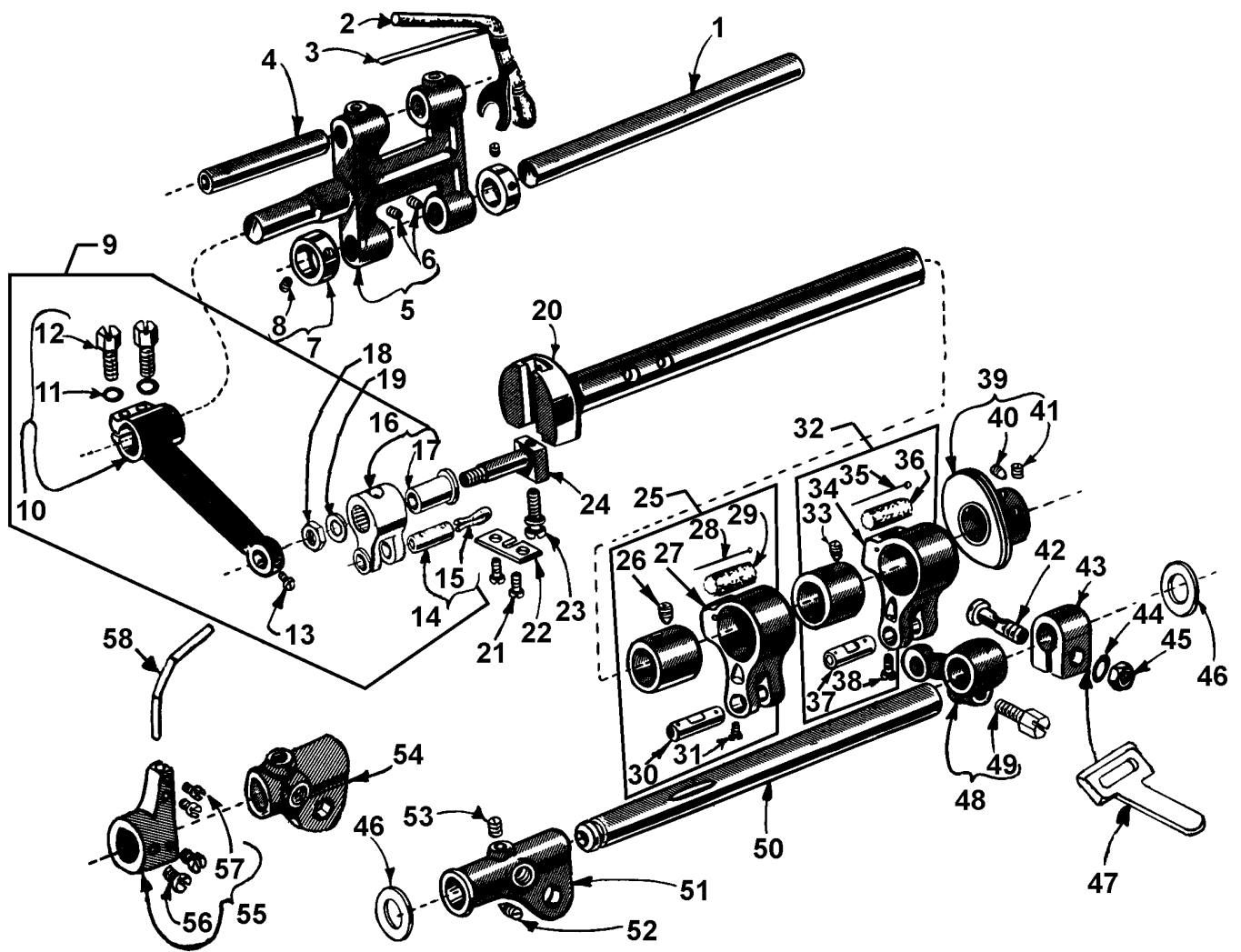

FEED ROCKER SHAFT, MAIN SHAFT AND LOOPER ROCKER FRAME ROCKER SHAFT PARTS

Ref. No.	Part No.	Description	Amt. Req.
1.	8	Feed Rocker Shaft	1
2.	51134P	Lubricating Felt	1
3.	51134R	Lubricating Felt Guard	1
4.	51134C	Feed Bar Shaft	1
5.	51235	Feed Rocker	1
6.	98	Screw	2
7.	482	Feed Rocker Shaft Collar	2
8.	98	Screw	2
9.	29476RF	Feed Rocker Arm and Link Assembly	1
10.	51235X	Feed Rocker Arm	1
11.	51235G	Washer	2
12.	22519C	Screw	2
13.	77	Set Screw	2
14.	51054A	Feed Crank Link Pin	1
15.	666-149	Lubricating Felt	1
16.	51236M	Feed Crank Link Assembly	1
17.	51236L	Feed Crank Link Ferrule	1
18.	269	Nut, left thread	1
19.	20	Washer	1
20.	53722	Mainshaft	1
21.	22768	Screw	2
22.	51236B	Feed Crank Stud Cap	1
23.	82	Stitch Regulating Screw	1
24.	51236G	Feed Crank Stud	1
25.	29476BJ	Looper Avoid Eccentric Assembly	1
26.	22894D	Spot Screw	1
27.	51145	Feed Lift and Looper Avoid Eccentric Link	1
28.	P118	Pin	1
29.	666-82	Lubricating Felt	1
30.	51236J	Link Pin	1
31.	77	Screw	1
32.	29476AR	Looper Avoid Eccentric Assembly	1
33.	22894D	Spot Screw	1
34.	51145	Feed Lift and Looper Avoid Eccentric Link	1
35.	P118	Pin	1
36.	666-82	Lubricating Felt	1
37.	51236J	Link Pin	1
38.	77	Screw	1
39.	51423C	Take-up	1
40.	96	Time Spot Screw	1
41.	22580D	Set Screw	1
42.	55244G	Locking Stud	1
43.	51244N	Looper Rock Shaft Collar	1
44.	51216N	Washer	1
45.	18	Nut	1
46.	51244L	Thrust Washer	2
47.	52470	Stop, for looper connecting rod	1
48.	51244B	Looper Rock Shaft Arm	1
49.	22519H	Screw	1
50.	51144	Looper Rock Shaft	1
51.	51244	Looper Rocker Frame, for Style 53800B	1
52.	96	Spot Screw	1
53.	98	Set Screw	1
54.	52444B	Looper Rocker Frame, for Stle 53700B	1
55.	52825D	Looper Needle Guard Holder, for Style 53700B	1
56.	33174B	Screw	2
57.	77	Screw	2
58.	51325	Looper Needle Guard, for Style 53700B	1

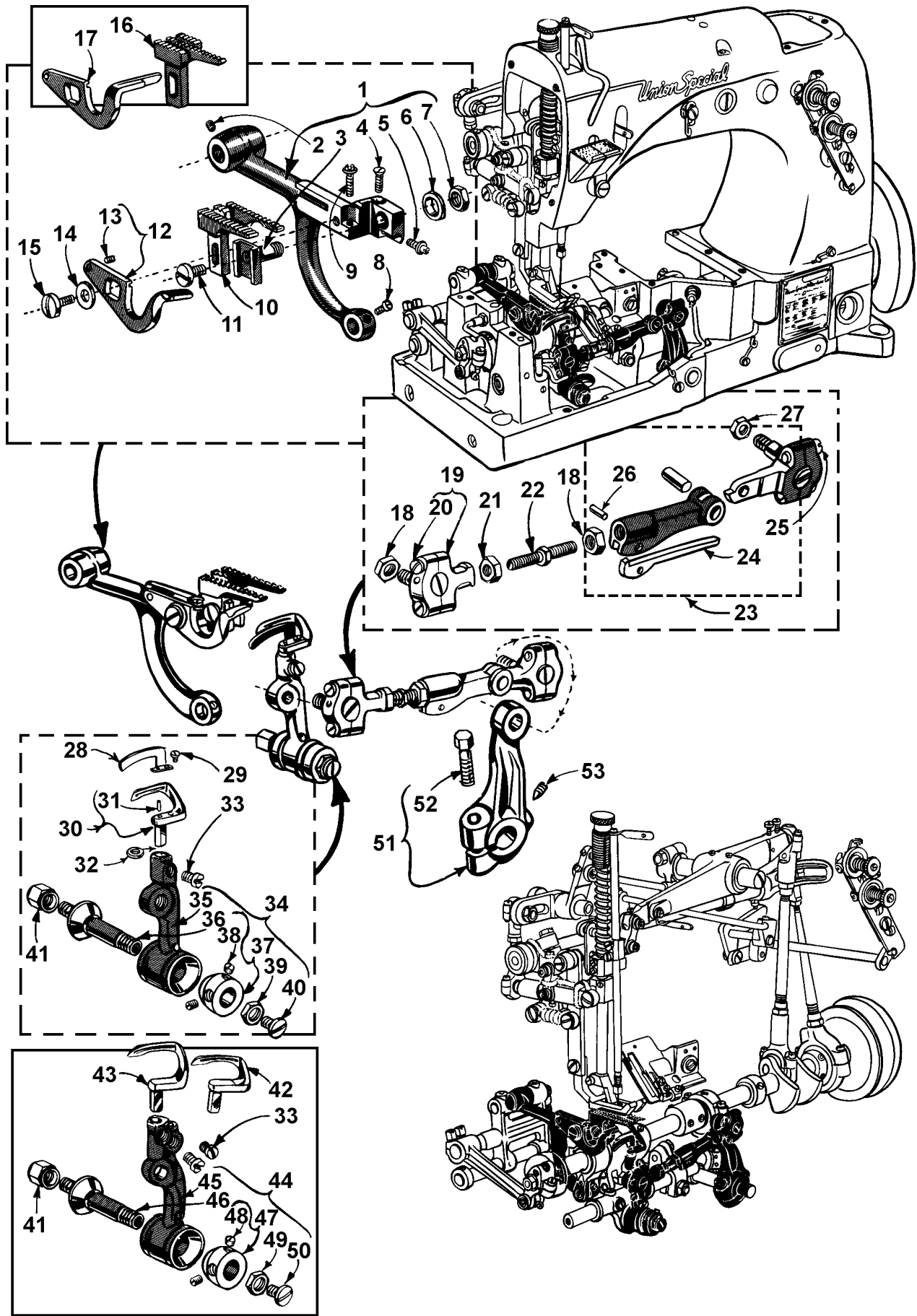

FEED BAR, LOOPER ROCKER AND CONECTING ROD PARTS

Ref. No.	Part No.	Description	Amt. Req.
1.	51134X	Feed Bar	1
2.	22560B	Set Screw	1
3.	56334E	Feed Dog Holder	1
4.	538	Feed Dog Height Adjusting Screw	1
5.	22863	Feed Dog Holder Adjusting Screw	1
6.	6042A	Washer	1
7.	258	Feed Dog Holder Nut	1
8.	77	Screw	1
9.	22834	Needle Guard Adjusting Screw	1
10.	53705A	Lower Feed Dog, for Style 53700B	1
11.	22528	Screw	1
12.	51225	Needle Guard, for Style 53700B	1
	53825	Needle Guard, for Style 53800B	1
13.	22801	Needle Guard Guide Screw	1
14.	51225W	Washer	1
15.	22585B	Screw	1
16.	53805A	Lower Feed Dog, for Style 53800B	1
17.	53825	Needle Guard, for Style 53800B	1
18.	18	Nut	2
19.	52841A	Looper Connecting Rod Ball Joint, left	1
20.	22729C	Bearing Cap Screw	2
21.	269	Nut, left thread	1
22.	51240D	Looper Connecting Rod, 1 11/32 inches long	1
23.	51241K	Looper Connecting Rod Ball Joint, right	1
24.	56341G	Spring	1
25.	22729C	Bearing Cap Screw	2
26.	50-458BLK	Spring Pin	1
27.	12538	Nut	1
28.	53710	Looper Needle Guard, for 53700B older models	1
29.	73A	Screw	1
30.	51409C	Looper, for Style 53700B	1
31.	1740	Looper Needle Guard Pin	1
32.	21211	Looper Collar, for Style 53700B	1
33.	73	Screw, for Style 53700B	1
	73	Screw, for Style 53800B	2
34.	29192	Looper Rocker Assembly, for Style 53700B	1
35.	51213	Looper Rocker	1
36.	51745	Looper Rocker Cone Stud	1
37.	15465F	Looper Rocker Cone	1
38.	22894W	Set Screw	2
39.	258	Lock Nut	1
40.	22829	Lock Nut Screw	1
41.	51246	Nut	1
42.	51508M18	Looper, front, for Style 53800B	1
43.	51909C	Looper, rear, for Style 53800B	1
44.	29192D	Looper Rocker Assembly, for Style 53800B	1
45.	51513	Looper Rocker	1
46.	51745	Looper Rocker Cone Stud	1
47.	15465F	Looper Rocker Cone	1
48.	22894W	Set Screw	2
49.	258	Lock Nut	1
50.	22829	Lock Nut Screw	1
51.	51242W	Looper Drive Lever	1
52.	22811B	Clamp Screw	1
53.	22894H	Spot Screw	1

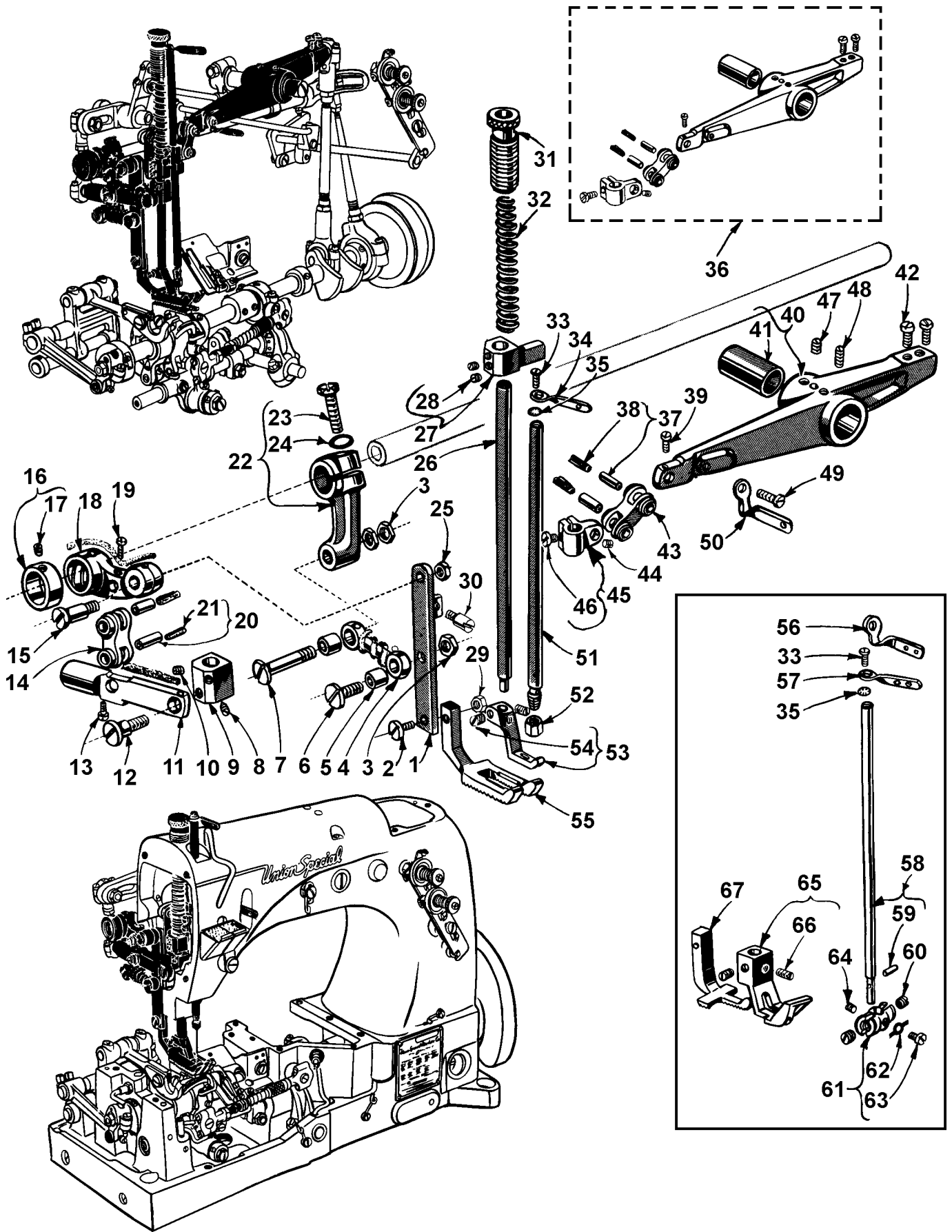

UPPER FEED DRIVE, NEEDLE BAR DRIVE AND PRESSER BAR PARTS

Ref. No.	Part No.	Description	Amt. Req.
1.	53753H	Upper Running Feed Bar	1
2.	22585S	Screw, for upper feed dog	1
3.	9937	Nut	3
4.	51770-88	Upper Running Feed Bar Spacing Link	1
5.	51771	Upper Running Feed Bar Link Bushing	2
6.	22773A	Screw	1
7.	22773B	Screw	1
8.	22764A	Screw	1
9.	53783D	Presser Bar Connection Block	1
10.	531	Screw	1
11.	53755A	Upper Running Feed Foot Lifter Link	1
12.	22787D	Screw	1
13.	J87J	Screw	1
14.	56354D	Connection Link	1
15.	22598D	Screw	1
16.	9660B	Upper Running Feed Drive Rock Shaft Collar	1
17.	98	Screw	2
18.	53752F	Upper Running Feed Lifter Drive Link	1
19.	J87J	Screw	1
20.	51054A	Link Pin	2
21.	666-149	Lubricating Felt	1
22.	53752D	Upper Running Feed Driving Lever	1
23.	627A	Clamp Screw	1
24.	80557	Washer	1
25.	12934A	Nut	1
26.	53788B	Presser Bar	1
27.	53783C	Presser Bar Connection and Guide	1
28.	22560B	Screw	2
29.	41071G	Nut	1
30.	33174B	Screw	1
31.	52889A	Presser Bar Bushing, upper and presser spring regulator	1
32.	53787	Presser Spring	1
33.	22768	Screw	1
34.	56358	Needle Bar Thread Eyelet, for Style 53700B	1

35. thru 67. See Following page

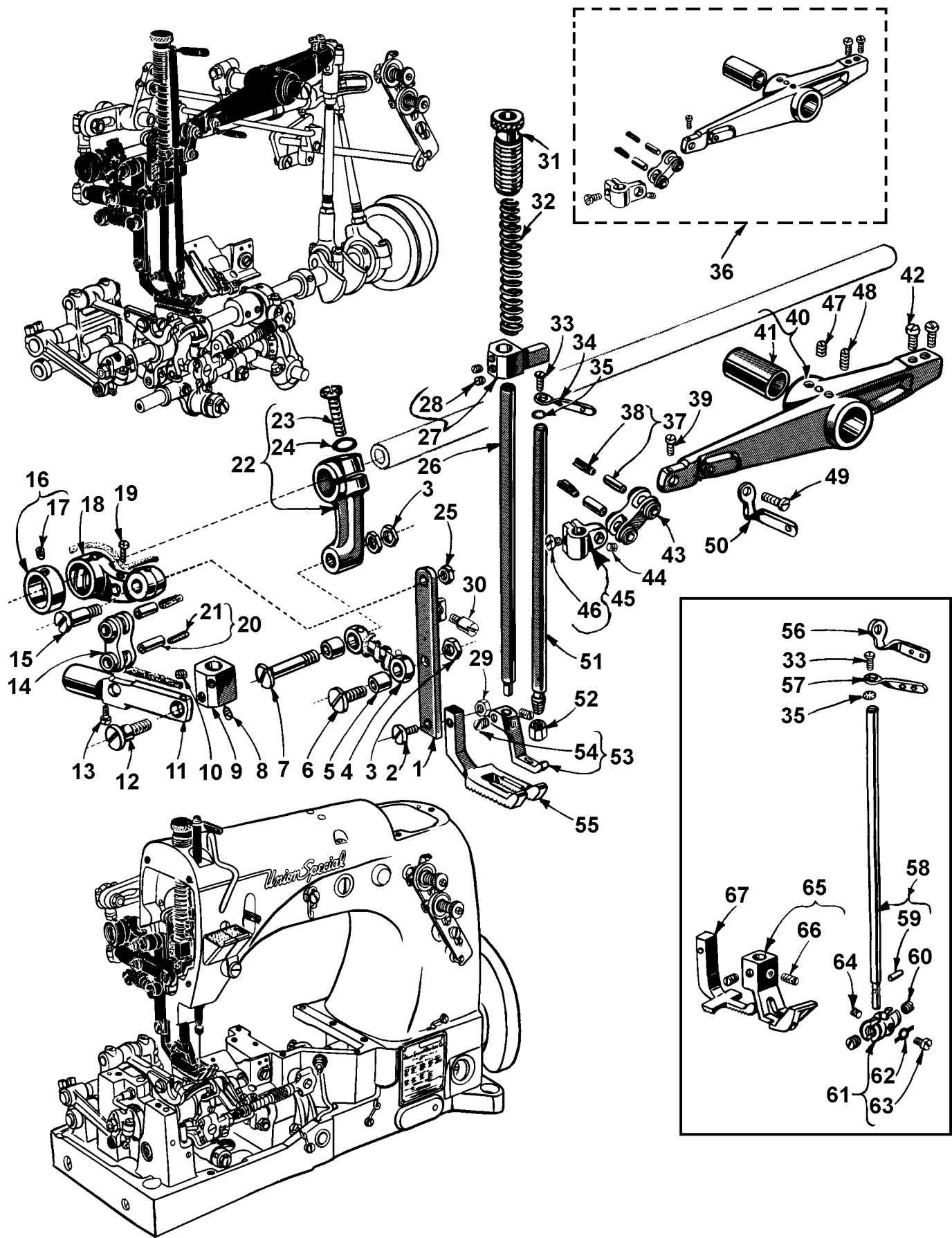

UPPER FEED DRIVE, NEEDLE BAR DRIVE AND PRESSER BAR PARTS CONTINUED

Ref. No.	Part No.	Description	Amt. Req.
1. thru 34. See Previous page			
35.	652C9	Needle Bar Eyelet Lock Washer	1
36.	29348AW	Needle Lever Assembly	1
37.	52336A	Needle Bar Connection Link Pin	2
38.	666-149	Lubricating Felt	1
39.	77	Screw	1
40.	53715A	Needle Lever	1
41.	56350B	Bushing	1
42.	22528	Screw	2
43.	56354D	Needle Bar Connection Link	1
44.	22564	Screw	1
45.	51254K	Needle Bar Connection	1
46.	22562A	Screw	1
47.	22591A	Screw	1
48.	HA81	Screw	1
49.	22768	Screw	1
50.	56358A	Needle Lever Thread Eyelet, for Style 53700B	1
51.	51217	Needle Bar, for Style 53700B	1
52.	56	Needle Clamp Nut, for Style 53700B	1
53.	53720	Presser Foot, for Style 53700B	1
54.	78	Screw, for Style 53700B	2
55.	53726	Upper Feed Dog, for Style 53700B	1
56.	56458	Needle Lever Thread Eyelet, for Style 53800B	1
57.	56458A	Needle Bar Thread Eyelet, for Style 53800B	1
58.	56517B18	Needle Bar, for Style 53800B	1
59.	50J16	Needle Stop Pin	1
60.	98	Set Screw, for needles for Style 53800B	2
61.	7018E5	Needle Bar Head, for Style 53800B	1
62.	7040-6	Thread Guide	1
63.	187B	Thread Guide Screw	1
64.	89	Screw, for Style 53800B	1
65.	53820-18	Presser Foot, for Style 53800B	1
66.	88	Screw	2
67.	53826	Upper Feed Dog, for Style 53800B	1

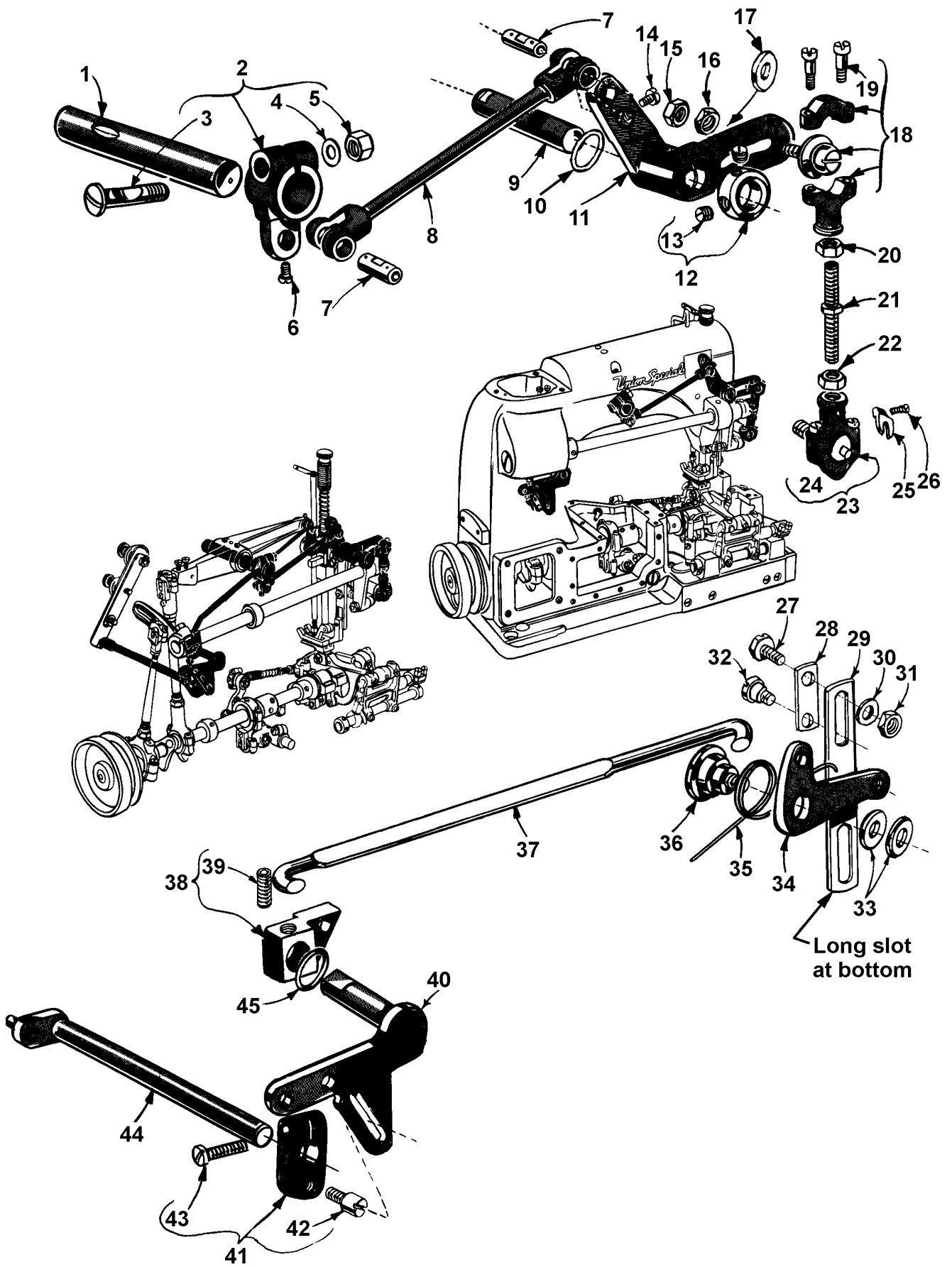

UPPER FEED LIFT AND PRESSER FOOT LIFTER PARTS

Ref. No.	Part No.	Description	Amt. Req.
1.	53750	Needle Lever and Upper Feed Lift Driving Lever Shaft	1
2.	53754	Upper Running Feed Lift Driving Lever	1
3.	55235D	Locking Stud	1
4.	6042A	Locking Stud Washer	1
5.	55235E	Locking Stud Nut	1
6.	77	Screw	1
7.	51236J	Link Pin	2
8.	53754A	Upper Running Feed Driving Connecting Rod Ball Joint Assembly	1
9.	53754F	Upper Feed Bell Crank Lever Shaft	1
10.	51242L	Washer	1
11.	53754D	Upper Feed Bell Crank Lever	1
12.	482C	Collar	1
13.	22894C	Set Screw	2
14.	22768	Screw	1
15.	18	Ball Joint Locking Nut	1
16.	15037A	Ball Joint Regulating Nut	1
17.	21657E	Washer, for 53754G	1
18.	53754G	Bell Crank Lever Ball Joint, upper	1
19.	22729C	Bearing Cap Screw	2
20.	15037A	Nut, right thread	1
21.	43242N	Connecting Rod, one inch long	1
22.	43242P	Nut, left thread	1
23.	43241D	Bell Crank Lever Ball Joint, lower	1
24.	22729C	Bearing Cap Screw	2
25.	41255B	Fork, for 43241D	1
26.	22747	Screw, for 41255B	1
27.	22882	Screw	1
28.	53783R	Presser Foot Lifter Lever Adjusting Plate	1
29.	53783P	Presser Foot Lifter Lever Link, adjustable	1
30.	20	Washer	1
31.	18	Nut	1
32.	9255	Washer	2
33.	240	Screw	1
34.	53783L	Presser Foot Lifter Lever Bell Crank	1
35.	52883S	Presser Foot Lifter Lever Bell Crank Spring	1
36.	22557B	Screw	1
37.	56383AB	Presser Foot Lifter Lever Connecting Rod	1
38.	53783N	Presser Foot Lifter Lever, internal	1
39.	22537	Screw	1
40.	53783T	Presser Foot Lifter and Tension Disc Release Lever	1
41.	21657Y	Tension Release and Foot Lifter Lever Shaft Connection	1
42.	402	Screw	1
43.	22596	Screw	1
44.	21657W	Tension Release and Foot Lifter Lever Shaft	1
45.	660-207	Oil Seal Ring	1

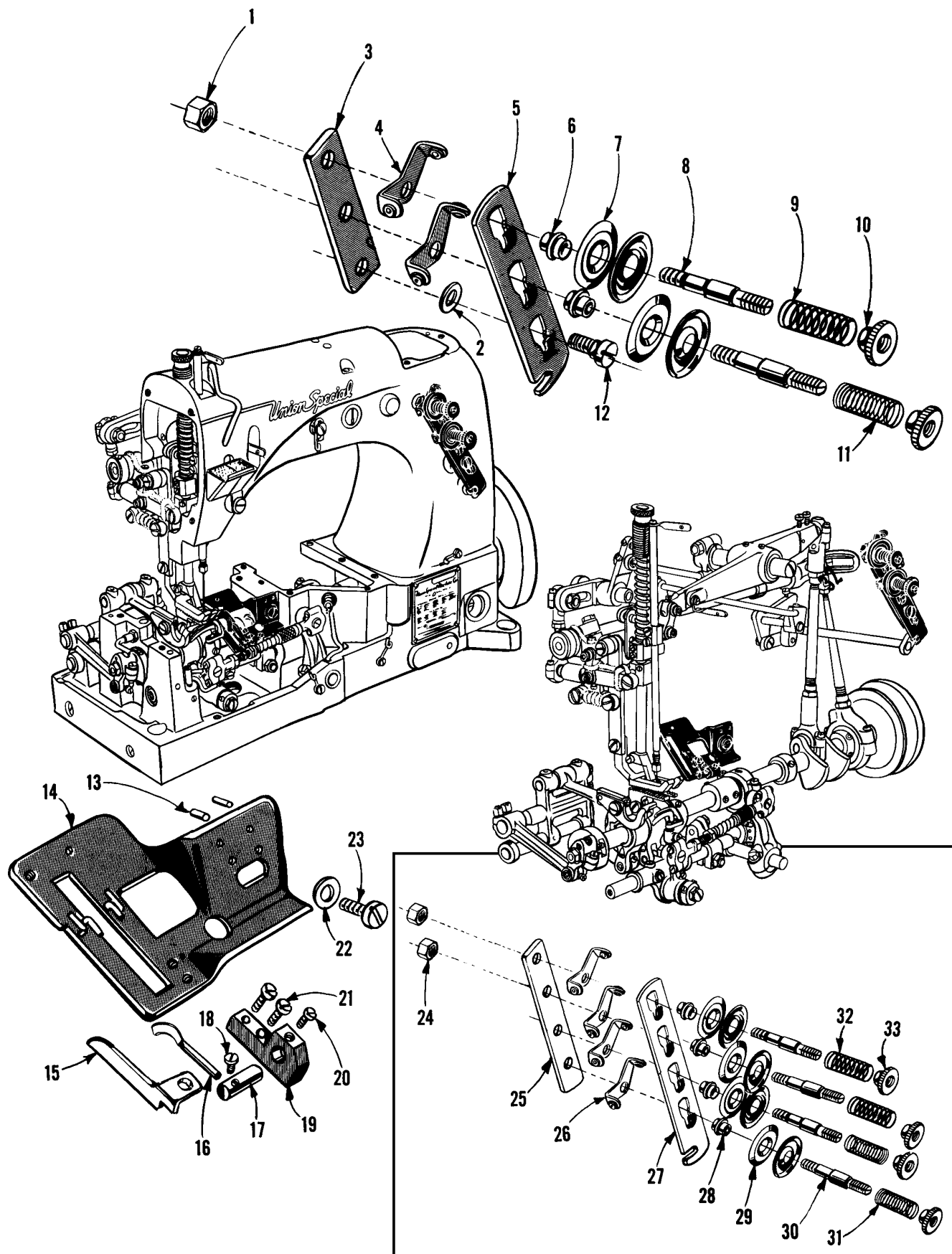

THREAD TENSION PARTS FOR SINGLE NEEDLE MACHINE

Ref. No.	Part No.	Description	Amt. Req.
1.	43266	Tension Post Nut	1
2.	80557	Spacing Washer	3
3.	52892	Tension Post Support	1
4.	51192G	Tension Post Thread Eyelet	2
5.	21657-3	Tension Disc Separator	1
6.	51292A	Tension Post Ferrule	2
7.	109	Tension Disc	4
8.	51292G	Tension Post	2
9.	51292F14	Tension Spring, needle thread	1
10.	51292C	Tension Regulating Nut	2
11.	51292F1	Tension Spring, looper thread	1
12.	22598C	Screw	1

LOOPER THREAD TAKE-UP PARTS

13.	50-216BLK	Dowel Pin	2
14.	51257P	Cast-off Support Plate	1
15.	51204B	Auxiliary Cast-off	1
16.	51204	Cast-off Wire	1
17.	51204A	Cast-off Wire Support	1
18.	22798A	Screw	1
19.	51204C	Cast-off Retaining Wire Support Bracket	1
20.	77	Screw	1
21.	J87J	Screw	2
22.	21657E	Washer	1
23.	22528	Screw	1

THREAD TENSION PARTS FOR TWO NEEDLE MACHINE

24.	43266	Tension Post Nut	2
25.	56382X	Tension Post Support	1
26.	51192G	Tension Post Thread Eyelet	4
27.	21657-4	Tension Disc Separator	1
28.	51292A	Tension Post Ferrule	4
29.	109	Tension Disc	8
30.	51292G	Tension Post	4
31.	51292F1	Tension Spring, looper thread	2
32.	51292F14	Tension Spring, needle thread	2
33.	51292C	Tension Regulating Nut	4

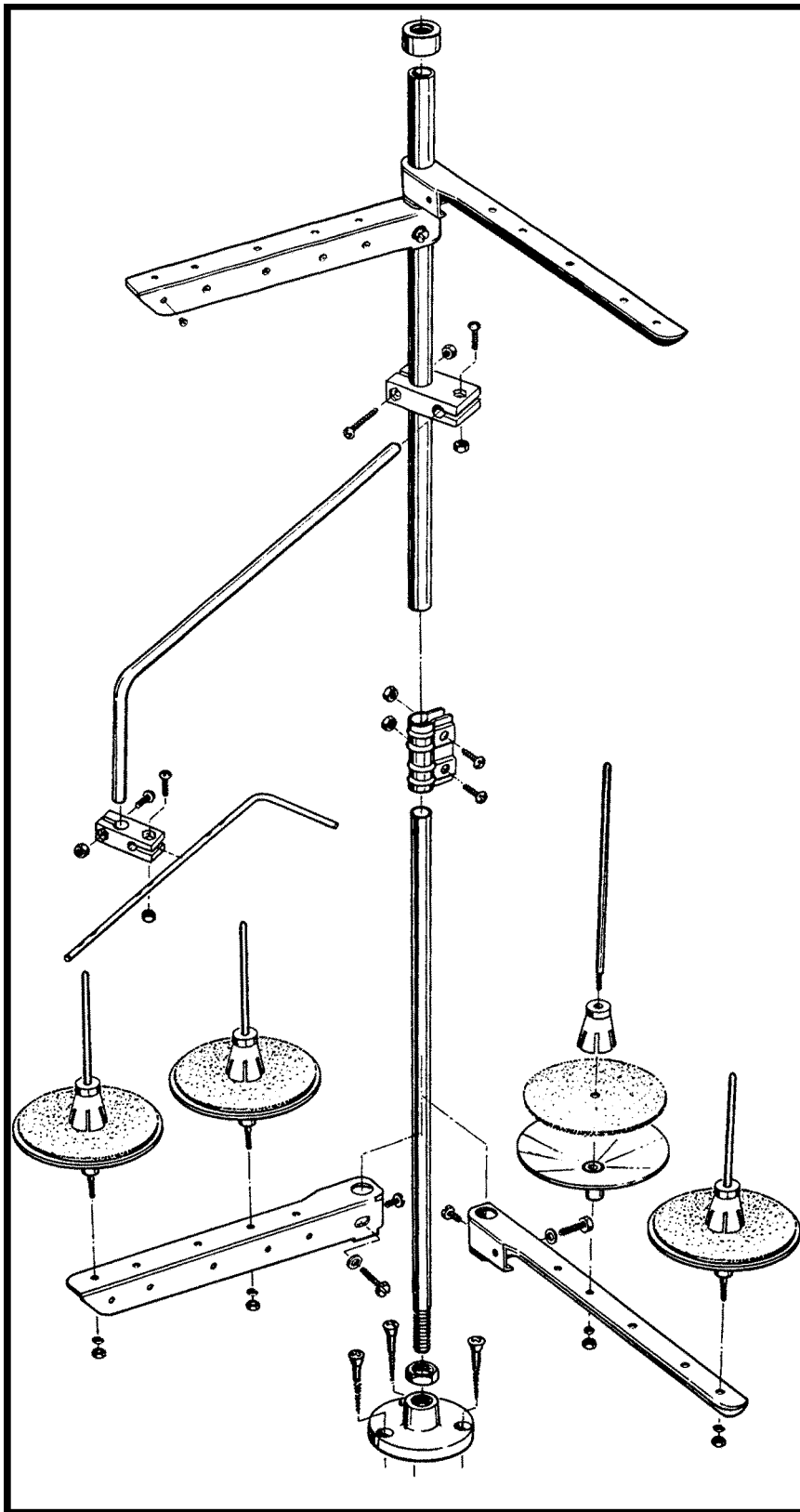

1

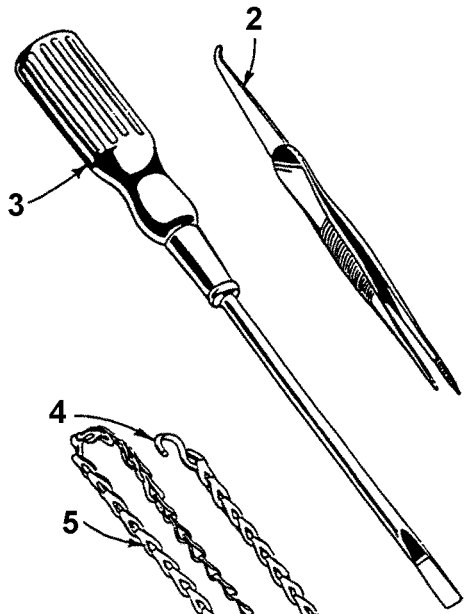

3

2

4

5

6

ACCESSORIES

Ref. No.	Part No.	Description	Amt. Req.
1.	21101W4	Thread Stand, complete, for Style 53800B	1
-	21101W2	Thread Stand, complete, for Style 53700B	1
2.	12288403	Tweezer	1
3.	21201	Screw Driver	1
4.	660-264	Hook	1
5.	421D28	Treadle Chain	1
6.	21388	Wrench, single end, for 3/8 inch nut	1

NOTES

NUMERICAL INDEX OF PARTS

<u>Part No.</u>	<u>Page No.</u>	<u>Part No.</u>	<u>Page No.</u>	<u>Part No.</u>	<u>Page No.</u>	<u>Part No.</u>	<u>Page No.</u>
109	33	22587	21	33174B	23, 27	51242S	19
12288403	35	22591A	29	35178D	19	51242W	25
12538	25	22596	31	35731A	15	51242Y	21
12934A	15, 27	22598C	33	35772H	15	51243C	21
12982	21	22598D	27	39582L	17	51244	23
136	15	22729	21	402	31	51244B	23
15037A	31	22729C	21, 25, 31	41071G	27	51244L	23
15430D	21	22733B	19	41255B	21, 31	51244N	23
15465F	25	22747	21, 31	41394A	19	51246	25
158B	15	22760A	15	421D28	35	51254C	17
1740	25	22764A	27	43241D	31	51254D	17
18	23, 25, 31	22768	23, 27	43242N	31	51254K	29
187B	29	22768	29, 31	43242P	31	51257P	33
20	15, 19, 23	22773A	27	43266	33	51270B	15
21101W2	35	22773B	27	454A	21	51280J	15
21101W4	35	22787D	27	482	23	51280K	15
21201	35	22798A	33	482C	31	51281AC	15
21211	25	22801	25	50-216BLK	33	51281P207	15
21375BQ	17	22811	21	50-458BLK	25	51282AH	19
21388	35	22811B	25	50-648BLK	15	51290T	17
21396AG	15	22823A	19	50-789BLK	17	51291A	15
21396BN	15	22823B	19	50J16	29	51292A	33
21657-3	33	22829	25	51054A	23, 27	51292C	33
21657-4	33	22834	25	51134C	23	51292F1	33
21657E	31, 33	22839	15	51134P	23	51292F14	33
21657W	31	22839C	15	51134R	23	51292G	33
21657X	17	22845B	15	51134X	25	51295A	19
21657Y	31	22848	15, 19	51144	23	51321G	21
22513D	15	22852A	21	51145	23	51325	23
22517B	15	22863	25	51192G	33	51382B	15
22519C	23	22882	31	51204	33	51409C	25
22519H	23	22883A	19	51204A	33	51423C	23
22524	15	22889A	15	51204B	33	51493AG	19
22528	15, 25	22889C	19	51204C	33	51493AH	19
22528	29, 33	22889D	15	51213	25	51493AY	19
22537	31	22894C	21, 31	51216	21	51493BH	19
22539D	17	22894D	21, 23	51216N	23	51493BJ	19
22539H	15	22894E	21	51217	29	51493BK	19
22541B	17	22894H	21, 25	51225	25	51493BP	21
22548	19	22894W	25	51225W	25	51493BQ	19
22557B	31	240	31	51235	23	51493BR	19
22559A	21	258	21, 25	51235G	23	51493D	19
22559B	21	258A	19	51235X	23	51508M18	25
22559E	21	269	21, 23, 25	51236B	23	51513	25
22560B	17, 21	29066X	21	51236G	23	51745	25
22560B	25, 27	29105Q	21	51236J	23, 31	51770-88	27
22562A	29	29126BJ	21	51236L	23	51771	27
22564	29	29192	25	51236M	23	51909C	25
22569B	19, 21	29192D	25	51240D	25	52336A	29
22570	15	29348AW	29	51241K	25	52444B	23
22571A	19	294	15	51242C	17	52470	23
22580D	23	29476AR	23	51242L	21	52825D	23
22585A	15	29476BJ	23	51242M	21	52841A	25
22585B	25	29476DT	21	51242P	21	52841G	21
22585S	27	29476RF	23	51242R	17	52841J	21

NUMERICAL INDEX OF PARTS

<u>Part No.</u>	<u>Page No.</u>	<u>Part No.</u>	<u>Page No.</u>	<u>Part No.</u>	<u>Page No.</u>	<u>Part No.</u>	<u>Page No.</u>
52849	21	53783C	27	77	23, 25, 29		
52849C	21	53783D	27	77	31, 33		
52854	21	53783L	31	78	29		
52882AA	17	53783N	31	8	23		
52882AC	17	53783P	31	80	15		
52882AD	17	53783R	31	80557	27, 33		
52882AE	19	53783T	31	80630C	21		
52882AS	19	53787	27	80689D	17		
52882AT	19	53788A	17	81	21		
52882L	19	53788B	27	82	23		
52882P	17	53790A	17	88	29		
52882Y	17	538	25	89	29		
52883R	17	53805A	25	90	17		
52883S	31	53820-18	29	9255	31		
52889A	27	53824A18	15	93	17		
52890C	17	53825	25	95	15, 21		
52891B	17	53826	29	96	23		
52892	33	55235D	31	9660B	21, 27		
52894AB	17	55235E	31	97A	21		
52894AC	17	55244G	23	98	21, 23, 27, 29		
52894AK	17	56	29	98A	15		
52936	19	56334E	25	9937	27		
52944T	17	56341G	25	HA81	29		
52944U	17	56350B	29	J87J	27, 33		
52A	15	56354D	27, 29	PI18	23		
531	19, 27	56358	27				
53701	15	56358A	29				
53705A	25	56382X	33				
53710	25	56383AB	31				
53715A	29	56390E	21				
53716	21	56458	29				
53720	29	56458A	29				
53722	23	56517B18	29				
53724A	15	6042A	25, 31				
53726	29	605A	15				
53750	31	627A	27				
53750A	17	643-127BLK	19				
53750B	17	652C9	29				
53752	21	660-136	19				
53752D	27	660-202	21				
53752F	27	660-207	31				
53753G	15	660-264	35				
53753H	27	666-111	19				
53754	31	666-114	19				
53754A	31	666-118	19				
53754D	31	666-149	23, 27				
53754F	31	666-149	29				
53754G	31	666-179	19				
53755A	27	666-53	21				
53758	15	666-65	19				
53780	15	666-82	23				
53780A	15	7018E5	29				
53780B	15	7040-6	29				
53782B	15	73	25				
53782E	15	73A	25				

Union Special Corporation
Corporate Office
One Union Special Plaza
Huntley, IL 60142
Phone: 847•669•5101
Fax: 847•669•4454

Union Special GmbH
European Distribution Center
Raiffeisenstrasse 3
D-71696 Möglingen, Germany
Tel: 49•07141•247•0
Fax: 49•07141•247•100

JUKI CORPORATION
INTERNATIONAL SALES DIVISION
8-2-1, KOKURYO - CHO,
CHOFU-SHI, TOKYO 182, JAPAN
PHONE: 03(3430)4001~5
FAX: 03(3430)4909 . 4914 . 4984



Union Special
INDUSTRIAL SEWING EQUIPMENT