

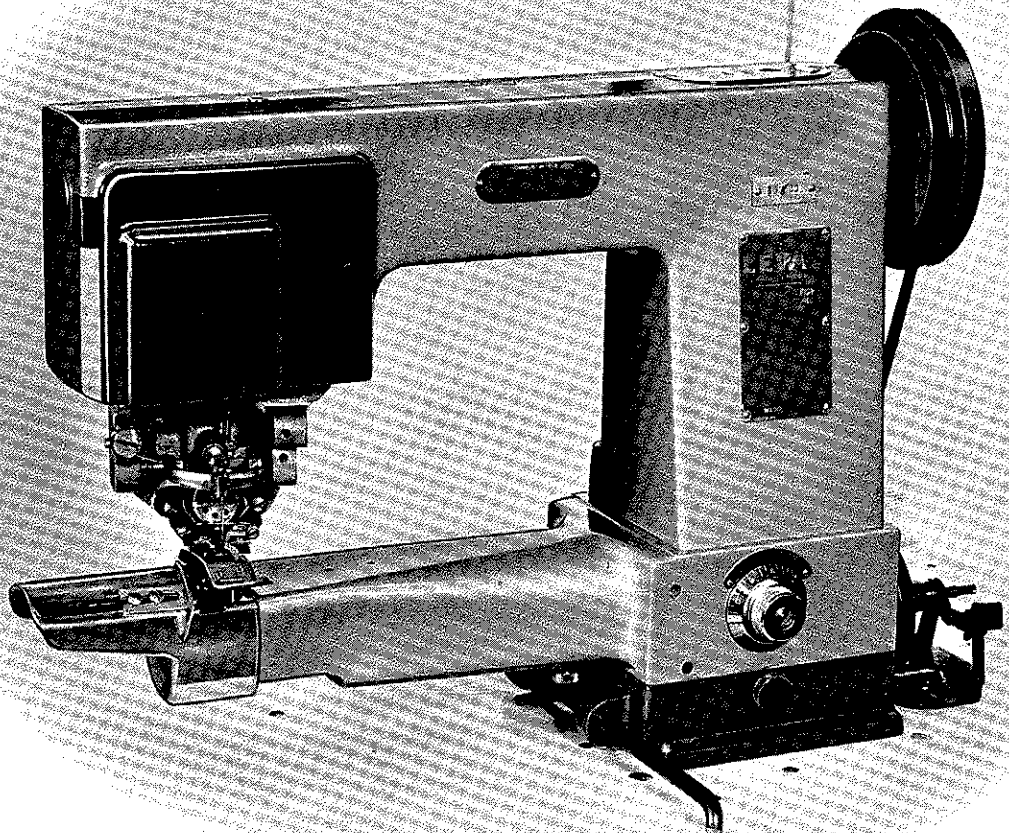

*Union Special*<sup>®</sup>  
LEWIS<sup>®</sup> • COLUMBIA<sup>®</sup>

INDUSTRIAL  
SEWING  
MACHINES

STYLE  
16-460



CATALOG  
No.  
194-14

LIST OF PARTS  
AND  
INSTRUCTIONS

**UNION SPECIAL CORPORATION**

CHICAGO

Catalog No. 194-14  
(Supplement to Catalog No. 194-6)

INSTRUCTIONS

FOR

ADJUSTING AND OPERATING

LIST OF PARTS

Style 16-460

First Edition

Copyright 1966  
by  
Union Special Corporation  
Rights Reserved in All Countries

**UNION SPECIAL CORPORATION**  
INDUSTRIAL SEWING MACHINES  
**CHICAGO**

Printed in U. S. A.

May, 1976

## IDENTIFICATION OF MACHINES

Each UNION SPECIAL LEWIS machine carries a style number, which, in this class of machines, is stamped in the style plate on the front of the column.

The serial number of each machine is stamped in the main frame at the left upper main shaft bearing.

## APPLICATION OF CATALOG

This catalog is a supplement to catalog No. 194-6 and should be used in conjunction therewith. Consult catalog No. 194-6, machine Style 16-260, for all parts not illustrated or described in this catalog. At the back of the book the parts are illustrated and listed by part number, name and amount required.

This catalog applies specifically to the Standard Style of machine as listed herein. References to direction such as right, left, front, back, up or down, etc., are given from the operators position while seated at the machine. Operating direction of handwheel is away from the operator.

## DESCRIPTION OF MACHINE

Style 16-460 is a high production, single curved needle, two thread lockstitch, blindstitch, cylinder base machine for felling sleeves over pre-attached buttons at cuffs on tropical and medium weight suitcoats. Machine fitted with end cover for quick inserting and removal of sleeves and linings. Minimum sleeve diameter of 4 3/4 inches. Needle travels left to right and penetrates at an angle of 15 degrees to line of feed. Machine equipped with calibrated depth penetration adjustment, lower feed and kneelifter for inserting and removing work. Work support plate not included. Maximum work space to right of needle is 10 inches.

NOTE: The looper and spreader assembly is not included with this machine and, therefore, the machine will produce a straight stitch only.

## SPEED

The recommended speed of these machines is 1500 R. P. M.

## NEEDLES

Use only genuine UNION SPECIAL LEWIS needles. They are stamped with the word "LEWIS" on the shank.

Needles for the Lewis Class 16 machines are available in all the required sizes in both uniform blade and ball eye.

The following types and sizes are available:

<u>Uniform Blade</u>	<u>Blade Dia.</u>	<u>Ball Eye</u>	<u>Blade Dia.</u>
29 BC	075/029	29 BD	065/025
29 BC	090/036	29 BD	075/029
29 BC	100/040	29 BD	090/036
29 BC	110/044	29 BD	100/040
		29 BD	110/044
		29 BD	140/054

Select a needle of the proper type and size for the material being sewn. Be sure that the eye is large enough to allow free passage of the thread or yarn used.

Immediately discard any needle which may have a hooked or blunt point.

To have needle orders promptly and accurately filled, an empty container, a sample needle, or the type number should be forwarded. A complete order would read:

"100 Needles, Type 29 BD-100/040.

## CHANGING NEEDLE

When changing needle, make sure that it is inserted in the needle carrier as far as it will go, and tighten clamp screw completely.

Immediately discard any needle which may have a hooked or blunt point, as improper needle penetration will result.

## THREADING

To thread the machine, turn pulley in operating direction until the needle carrier is in its highest position, and thread in accordance with threading diagram below. The threading is not pictorially accurate in that Style 16-460 is a left hand machine, but for the purpose of tracing the threading, it will suffice.

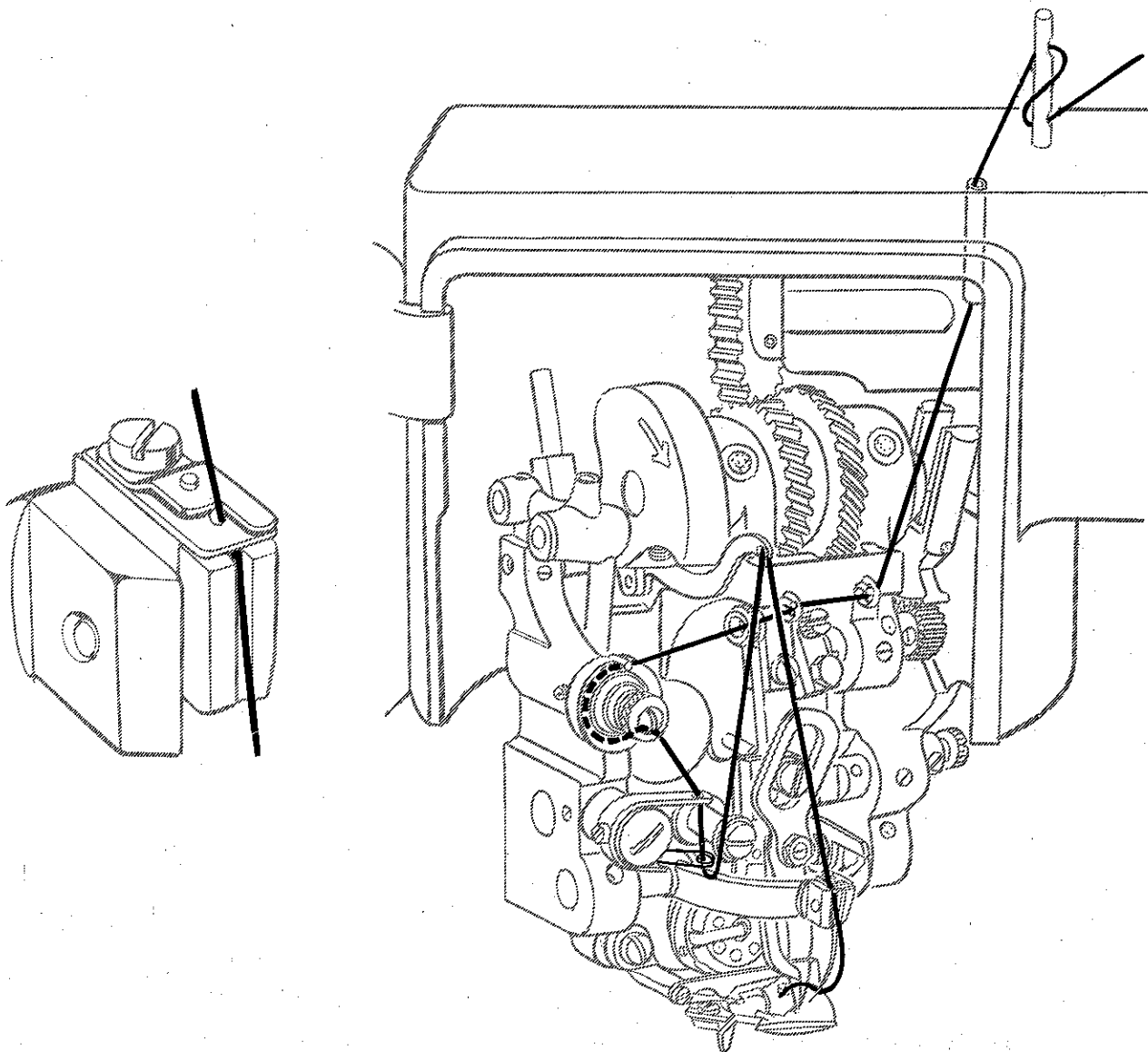

## OILING

These machines should be oiled twice daily, before the morning and afternoon starts. Use a good grade of straight mineral oil of a Saybolt viscosity of 90 to 125 seconds at 100 degrees Fahrenheit.

Most of the oiling places on these machines are readily identifiable because of the fact they are painted red. However, reference to the oiling diagram, on Page 6, will be beneficial.

Please note that it will be necessary to remove head cover, cylinder end cover, and to tilt the machine back from the sub-base to reach some of the oiling places.

Referring to the oiling diagram, it will be noted that there is a lubrication point marked "A".

Point "A" on the diagram refers to the cover over the hook driving gears, which are lubricated with a standard wheel bearing grease. Periodically, the cover should be removed and the grease replenished, if necessary. Tubes of grease may be ordered from Union Special under part No. 28604 P.

## ORDERING REPAIR PARTS

Order repair parts by their part number, giving description of the part, quantity needed and the style of the machine for which the part is required. Referring to the picture plate on page 8, the numbers on this page are merely reference numbers. On page 9, the numbers in the first column are the reference numbers only, and merely indicate the part in the illustration. Reference numbers should never be used in ordering parts. Always use the part number listed in the second column.

## IDENTIFYING PARTS

Where the construction permits, each part is stamped with its part number. Part numbers represent the same part, regardless of catalog in which they appear.

## USE GENUINE NEEDLES AND REPAIR PARTS

Success in the operation of these machines can be secured only with genuine UNION SPECIAL LEWIS Needles and Repair Parts as furnished by the Union Special Corporation, its subsidiaries and authorized distributors. They are designed according to the most approved scientific principles, and are made with utmost precision. Maximum efficiency and durability are assured.

Genuine needles are packaged with labels marked LEWIS *Union Special*. This trademark is your guarantee of the highest quality in materials and workmanship.

## TERMS

Prices are net cash and subject to change without notice. All shipments are forwarded f. o. b. shipping point. Parcel Post shipments are insured unless otherwise directed. A charge is made to cover postage and insurance.

OILING DIAGRAM

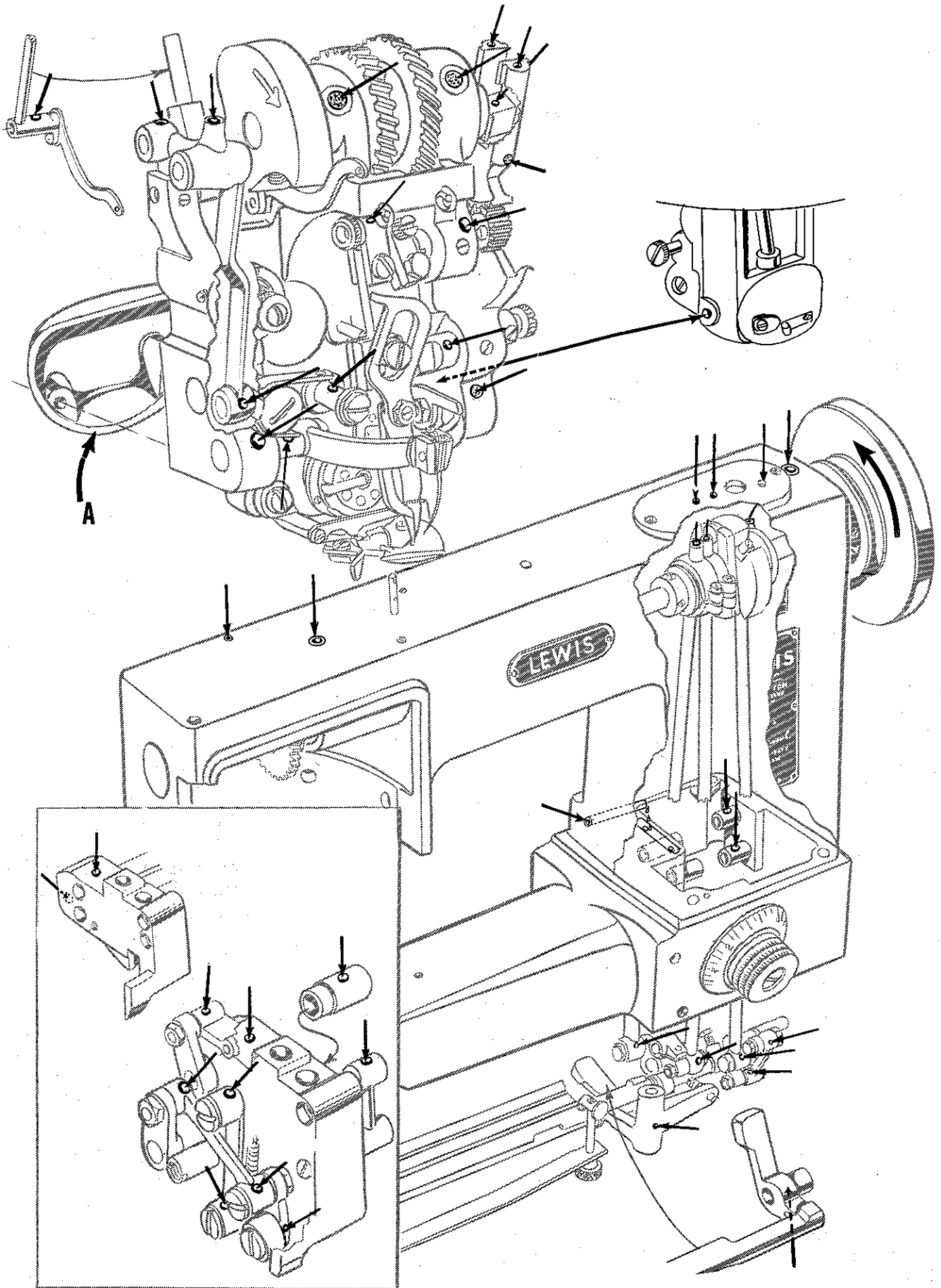

MISCELLANEOUS PARTS FOR STYLE 16-460

<u>Part No.</u>	<u>Description</u>	<u>Amt. Req.</u>
23-339	Feed Point -----	1
24-328	Feed Plate -----	1
432-304	Cylinder End Cover -----	1
75-252	Edge Guide -----	1
18-750	Screw, for No. 75-252 -----	2
40-38	Washer, for No. 75-252 -----	2

432-304

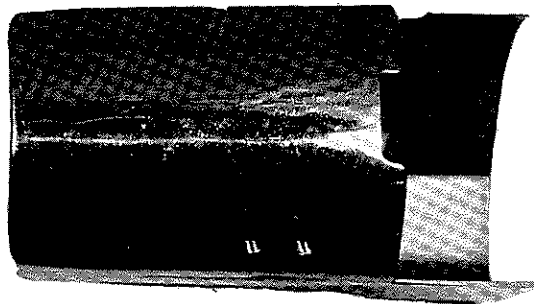

23-339



24-328

18-750 (2)



40-38 (2)



75-252

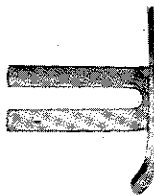

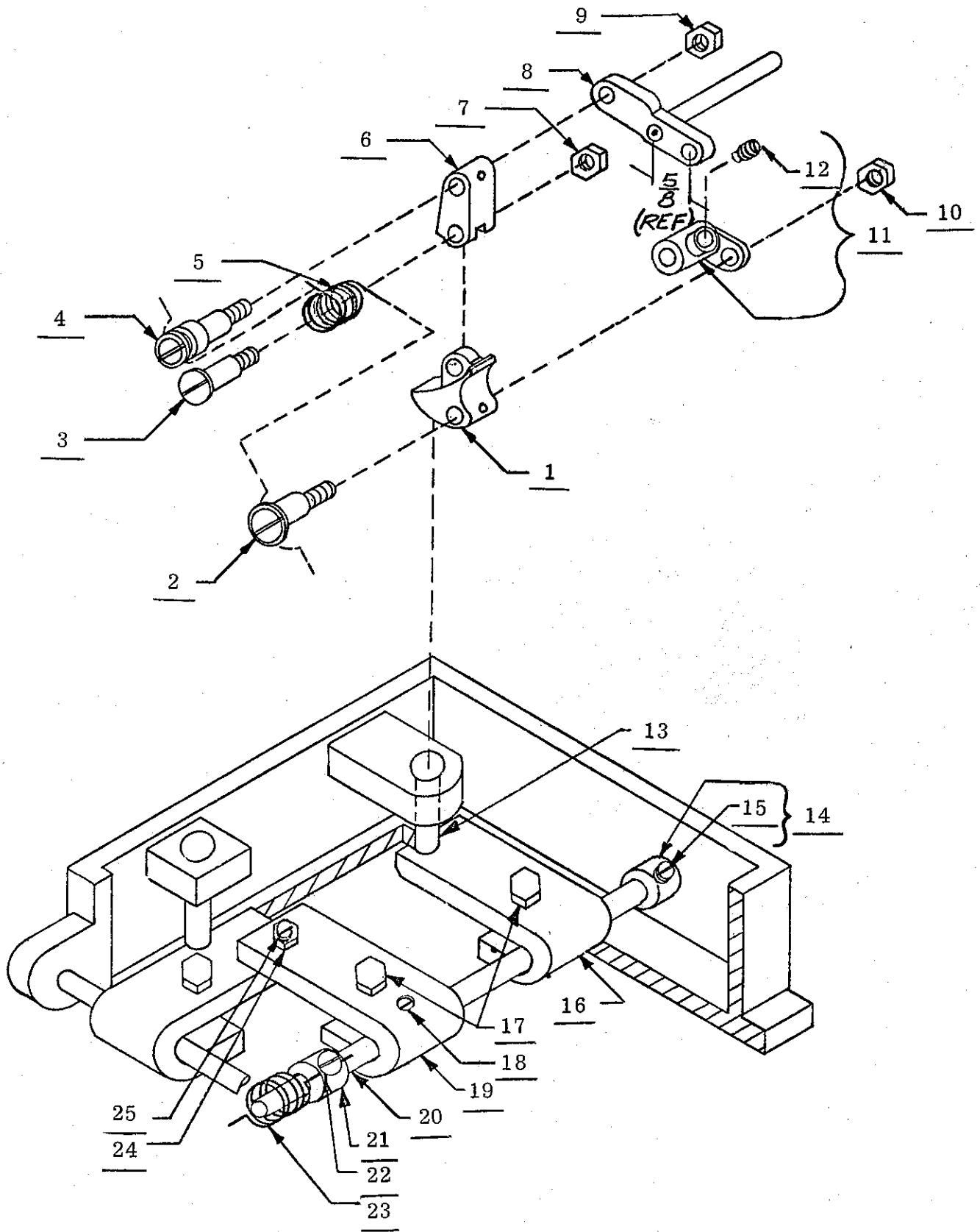



AUTOMATIC TOGGLE MECHANISM

<u>Ref. No.</u>	<u>Part No.</u>	<u>Description</u>	<u>Amt. Req.</u>
1	46-177	Toggle Link, Lower-----	1
2	18-1029	Shoulder Screw-----	1
3	18-872	Shoulder Screw-----	1
4	18-1067	Shoulder Screw-----	1
5	21-421	Spring-----	1
6	46-178	Toggle Link, upper-----	1
7	1009 L	Nut-----	1
8	48-169	Plunger Differential Crank-----	1
9	1012 L	Nut-----	1
10	1009 L	Nut-----	1
11	48-183	Plunger Rocker Crank-----	1
12	1147 L	Screw-----	1
13	22-299	Pin-----	1
14	1388 L	Collar-----	1
15	1025 L	Set Screw-----	1
16	45-422	Knee Press Lever-----	1
17	1384 L-1/2	Clamp Screw-----	2
18	1029 L	Set Screw-----	1
19	45-423	Lever-----	1
20	14-476	Toggle Mechanism Shaft-----	1
21	1388 L	Collar-----	1
22	18-327	Screw-----	1
23	21-286	Spring-----	1
24	1009 L	Nut-----	1
25	18-567	Stop Screw-----	1

NOTE: Automatic toggle mechanism available as extra send and charge item, but not furnished with machines with serial number above #913479.

# Union Special Wants to Help You Cut Sewing Machine Maintenance Costs

Union Special is offering two practical systems to help pinpoint and reduce your sewing machine maintenance costs: a record keeping system to help spot machines requiring abnormally high maintenance, and a parts inventory system to speed routine repairs.

## Machine Maintenance Records

Repair-prone machines or inexperienced competent operators can eat up your maintenance dollars in short order. To help spot these problems, Union Special suggests two variations of a simple maintenance record keeping system using cards provided by Union Special.

The first system utilizes a "Machine Maintenance Record" card (Form 237) for each sewing machine in a plant. When a repair is required, the card is pulled from the file and the repair date, parts used, and their cost are entered in the spaces provided and the card is refiled.

The second system is normally used when more detailed information on repair costs is desired. Two record cards are used: a "Repair Request Card" (Form 234), and a "Machine Repair Record" (Form 233). When a machine requires service, the forelady or foreman fills out the top of a "Repair Request Card" and gives it to a mechanic. He fills in the time the repair work is started, the parts used and their cost,

and the completion time. This data is then transferred to the permanent "Machine Repair Record" kept in the office.

Whichever system is used, management now has an invaluable tool to reduce needless maintenance costs.

## Repair Part Inventories

While record keeping tells management which machines require abnormally high maintenance, it does little to help reduce the downtime caused by routine repairs. To alleviate this situation, Union Special recommends that manufacturers establish a formal parts inventory system for each type of sewing machine they operate.

Excessive machine downtime and wasted hours by mechanics can be eliminated with an orderly in-plant inventory of the most commonly needed parts. There is no longer a need to cannibalize other machines for spare parts. Long waits for deliveries are avoided and machine downtime is kept to a minimum. The cost of a parts inventory is small when the overall savings are considered.

For free sample copies of the machine repair cards and spare part inventory lists for a variety of the most popular machines, contact your local Union Special Representative or write direct to Union Special.

## Union Special Styles 16-260, 16-460

Suggested Minimum Spare Parts List

Part Number	Description	Minimum Quantity Per 5 Machines	Part Number	Description	Minimum Quantity Per 5 Machines
405-320	Presser foot	1	437-2	Looper and spreader complete	1
23-322	Feed dog for 16-260	1	37-2	Looper spreader	1
or			17-104	Stud	1
23-339	Feed dog for 16-460	1	1025 L	Set screw	4
29 BD	Needles (specify size)	100	1029 L	Set screw	4
26-72	Plunger	1	1031 L	Spot screw	2
406-59	Needle guide, complete	2	1005 L	Set screw	4
1058 L	Screw for needle guide	2	1056 L	Bobbin case release	2
126-24	Crown	1	18-715	Screw for looper crank	4
1655 L	Crown bearing screw	1	1073 L	Screw for presser foot	2
21-214	Retaining spring	3	1047 L	Bobbin	4
1040 A-2L	Hook, complete	1	1014 L	Screw for needle clamp	4
411-6	Bobbin case	1	1015 L	Thread guide plate lower	4
1037 L	Hook gib	1	1016 L	Thread guide plate upper	4
1039 L	Screw for hook gib	4	1036 L	Screw for thread guide plate	2
21-245	Tension spring	2	1187 L	Thread controller spring	2
1046 L	Tension screw	6	1213 L	Screw for feed drive	2
18-912	Clamp screw	2	1020 L	Spot screw for feed drive	1

\*The parts and quantities listed above are intended to assist you in setting up the initial inventory of spare parts. An efficient inventory can only be established according to actual usage. The nature of the sewing operation will determine actual usage.

Helpful, authoritative information on the most efficient types of equipment for making virtually any machine sewed article is available from Union Special's Sales Promotion Department. Among the many interesting, illustrated bulletins that are available without obligation are the following:



- No. 240, "Men's, Women's, Children's Footwear"
- No. 249, "Rainwear"
- No. 250, "Men's Dress Shirts"
- No. 251, "Service Shirts and Pants"
- No. 252, "Men's Shorts and Pajamas"
- No. 253, "Overalls, Coveralls, and Dungarees"
- No. 254, "Men's Knit Underwear"
- No. 256, "Knit Outerwear"
- No. 259, "Men's Sports Shirts"
- No. 260, "Work Gloves"
- No. 262, "Cotton, Burlap, Jute, and Multiwall Paper Bags"
- No. 263, "Men's Clothing"
- No. 264, "Men's Women's, Children's Jackets"
- No. 265, "Women's Wear"
- No. 266, "Women's Wear And High Fashion"
- No. 267, "Corsets, Girdles, Brassieres"
- No. 268, "Children's Wear"
- No. 269, "Mattresses, Slip Covers, Furniture Upholstery"
- No. 271, "Awnings, Canopies, Tents, Tarps"
- No. 273, "Curtains & Drapes"
- No. 610, "Klipp-it"
- No. 710, "MCS ForMation Unit"
- No. 730, "MCS Automatic Dual Underfront Shirt Hemmer"
- No. 740, "MCS Automatic Rib-Knit Cuff Machine"
- No. 750, "Fusing Presses"
- No. 1100, "Lewis Blindstitch, Chainstitch, Lockstitch, Machines"
- No. 1105, "Button Sewers—Ticket Tackers"
- "Columbia Blindstitch, Saddle Stitch, and Tie Closing Machines"
- No. 1500, "Alteration Department Machines"



**UNION SPECIAL  
CORPORATION**

**HERE ARE HELPFUL  
BULLETINS and CATALOGS  
TO HELP YOU SOLVE  
SEWING PROBLEMS**

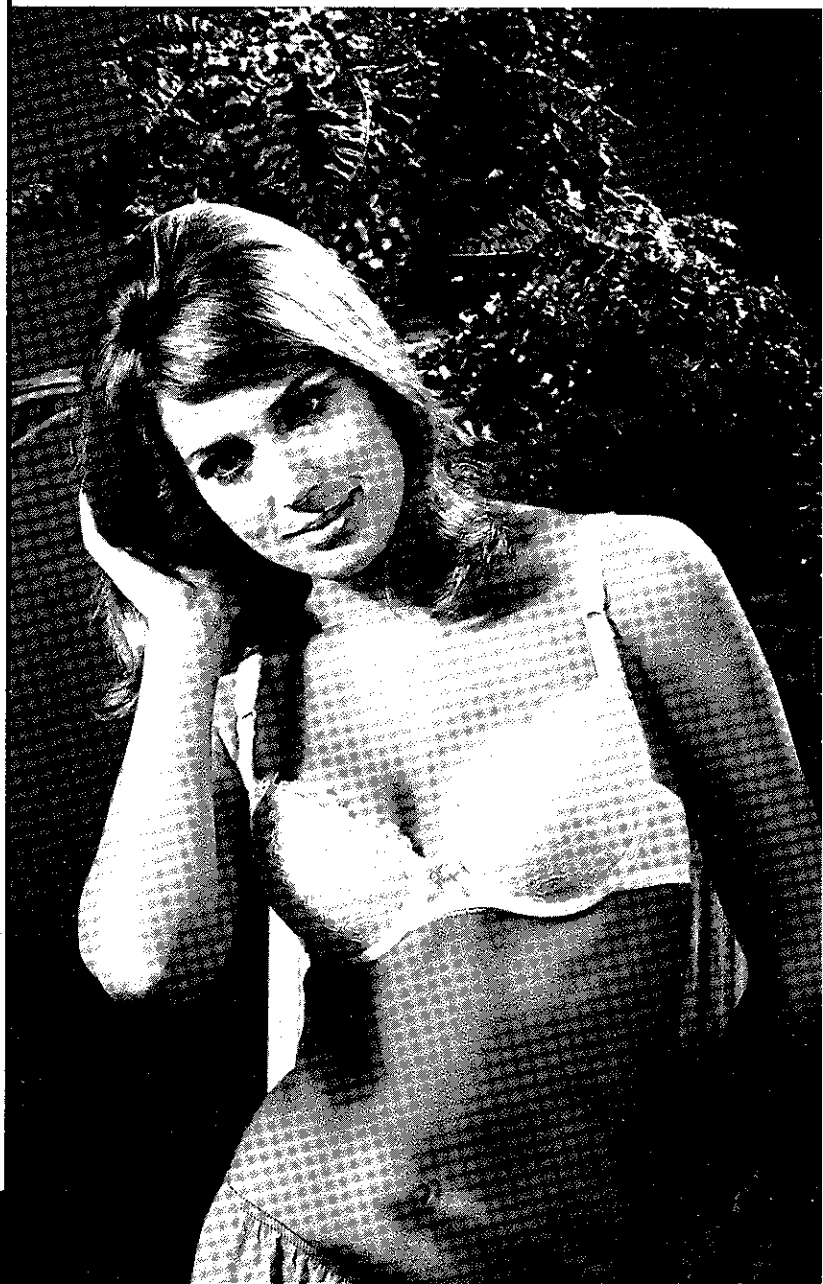



*Union Special*<sup>®</sup>  
INDUSTRIAL SEWING MACHINES

UNION SPECIAL maintains sales and service facilities throughout the world. These offices will aid you in the selection of the right sewing equipment for your particular operation. Union Special representatives and service men are factory trained and are able to serve your needs promptly and efficiently. Whatever your location, there is a Union Special Representative to serve you. Check with him today.

**ATLANTA, GA.**

**BOSTON, MASS.**

**CHICAGO, ILL.**

**DALLAS, TEXAS**

**LOS ANGELES, CAL.**

**NEW YORK, N. Y.**

**PHILADELPHIA, PA.**

**MONTREAL, CANADA**

**TORONTO, CANADA**

**BRUSSELS, BELGIUM**

**LEICESTER, ENGLAND**

**LONDON, ENGLAND**

**PARIS, FRANCE**

**STUTTGART, GERMANY**

Representatives and distributors in all important industrial cities throughout the world.

**UNION SPECIAL CORPORATION**  
400 N. FRANKLIN ST., CHICAGO, ILL. 60610