

SINGER* 691UTT

INDUSTRIAL PRODUCTS

Operator's Guide

Single Needle High Speed Lockstitch Machine
with Automatic Thread Trimmer

* A Trademark of THE SINGER COMPANY

Introducing the NEW SINGER Sewing Machine Model 691!

The most dependable, lightest running machine of its kind. This machine will produce top quality straight-line single-needle lock stitching.

The new concept thread trimmer mechanism permits thread trimming leaving only a minimum length needle thread end. This compact and most stylish machine with integrated console fits perfectly in the modern garment factories.

For best sewing results, we suggest you take a few moments to read through this operator's guide as you sit at your new machine.

GETTING TO KNOW YOUR MACHINE

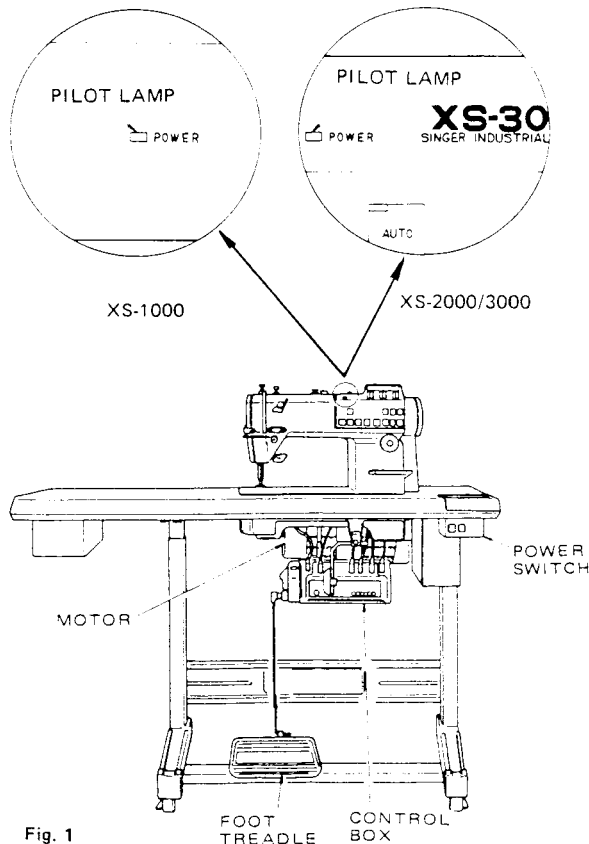

Fig. 1

Important safeguards

- Check and be sure the oil reservoir is filled with oil before operating the machine.
- Never let your machine rotate in reverse direction. The machine pulley must always turn over toward you. To check direction of rotation, connect ONLY the connector for needle positioner to the control box and run the machine.
- Turn off power switch and make sure the pilot lamp is off before tipping the machine back for cleaning and oiling or when making adjustments to movable parts.
- When turning on the power switch, keep your hands away from the needle and take-up lever guard areas.
- When machine is in operation, keep clear off all moving parts such as needle, take-up lever, machine pulley, V-belt, slack needle thread regulator, wiper, bobbin winder, motor, etc.

LUBRICATION

- The needle will not descend and the trimmer will not function when the treadle is heeled immediately after turning on the power switch or immediately after completion of thread trimming cycle. The needle will stop in down position and the trimmer will function properly once the treadle is depressed for normal sewing.

- Before filling the oil reservoir, make sure the plunger A is assembled to the oil reservoir as shown in Fig. 2.
- Fill oil reservoir to "HIGH" mark with Singer Type "C" oil.
- Run machine at slow speed and check oil flow through oil flow window. Correct lubrication is indicated by continuous stream of oil passing the oil flow window. Should this oil flow become erratic, stop the machine and do not run the machine again until the cause has been determined and corrected. (Fig. 3)

NOTE:

When a machine is NEW or has been idle for several weeks, it is advisable to oil the needle bar, take-up bearings and all other parts in movable contact. The automatic lubricating system will function effectively after running the machine at 2,500 ~ 3,000 revolutions per minute for 10 to 15 minutes and continue to lubricate all bearings. At least twice each month, check the oil level in the reservoir. Never allow the oil level to drop below "LOW" mark. Fill if needed. For best results, use Singer Type "C" oil which will produce a minimum of stain on fabrics even after a long period of storage.

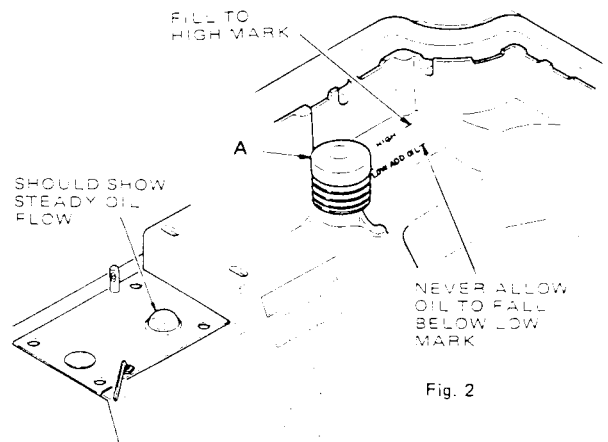

Fig. 2

Fig. 3

CORDS AND CONNECTIONS

- Turn off the power switch and make sure the pilot lamp is off before connecting or disconnecting the connectors to the control box. (Fig. 1)
- Pass the cords leading out from the machine through the hole provided in the table and connect to control box.
- Connect the cords to the terminals making sure they are correctly connected to their mating terminals as shown in Fig. 4 and 5.
- Be sure the cords are clear of moving parts such as V-belt etc.
- For detailed instructions on control box and console panel, refer to instruction book for needle positioner and console panel furnished with the machine.
- Following are the description of connector.
 - ① Connector for power supply
 - ② Connector for encoder
 - ③ Connector for wiper
 - ④ Connector for suction unit
 - ⑤ Connector for additional back tack and tension release
 - ⑥ Connector for back tack and trimmer
 - ⑦ Connector for presser foot lift
 - ⑧ Connector for synchronizer

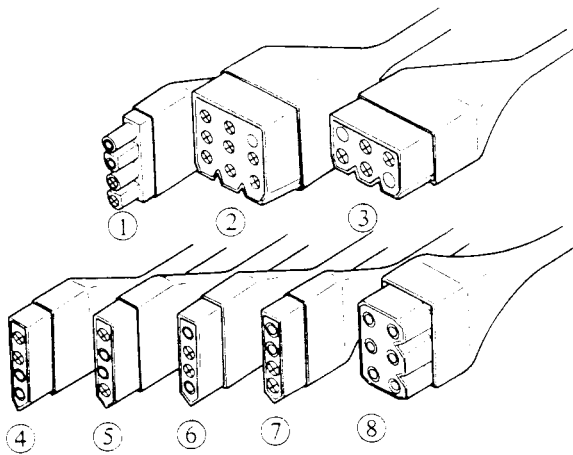

Fig. 4

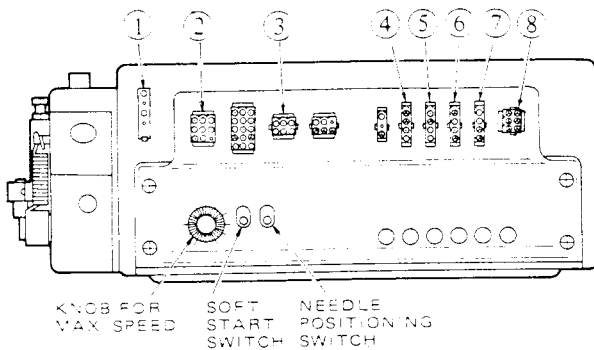

Fig. 5

SPEED

- Maximum recommended sewing speed of 691 series machines is as shown below.

machines	maximum sewing speed
691D 100/110/150/200/210/250	5.500 s.p.m.
691D 300/310/350	5.000 s.p.m.

- Sewing speed

Formula for calculation of sewing speed is:

$$\text{Sewing speed (s.p.m.)} = \frac{\text{O.D. of motor pulley (mm)} \times \text{Rotation of motor (r.p.m.)}}{\text{Diameter of machine pulley (74mm)}}$$

The relation between sewing speed and O.D. of motor pulley will be as shown below when rotation of the motor is 3.000 r.p.m.

O.D. of motor pulley (mm)	65	70	85	100	115	140
Sewing speed (s.p.m.)	2640	2840	3450	4050	4660	5680

- Never operate your machine at a speed higher than the recommended maximum sewing speed.
- Use type M belt.
- Desired sewing speed can be selected since thread trimming speed is set individually on this machine.

TO INSTALL THE ROCK SHAFT KNEE ARM

- Fasten rock shaft knee arm to oil reservoir as shown in Fig. 6.

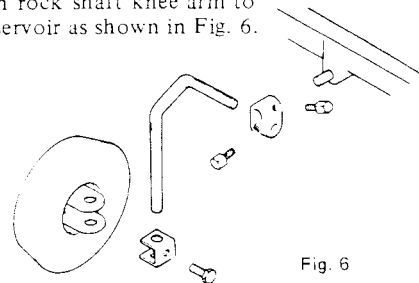

Fig. 6

TO SET UP THE THREAD UNWINDER

- Fasten thread unwinder firmly to the table as shown in Fig. 7.

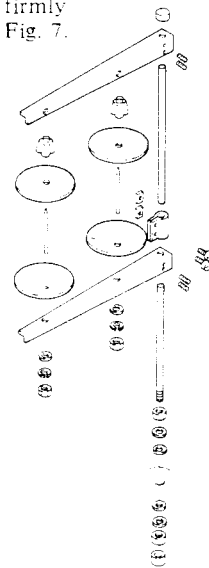

Fig. 7

TO INSTALL THE BELT GUARD

Fasten belt guard studs **A** to screw holes provided in the arm.
 Fit belt guard spacer **B** onto belt guard screw (long) **C** and fasten screw **C** to arm loosely.
 Slip recessed portion of belt guard **D** in between the spacer and screw head and tighten screw **C**.
 Fasten belt guard **E** to belt guard **D** with screw (short) **F** and then secure to studs **A** with two screws **G**.
 Drill two pilot holes in machine table at point **J**. Place belt guard **H** on table with its screw holes aligned with two pilot holes and fasten to table with two wood screws.

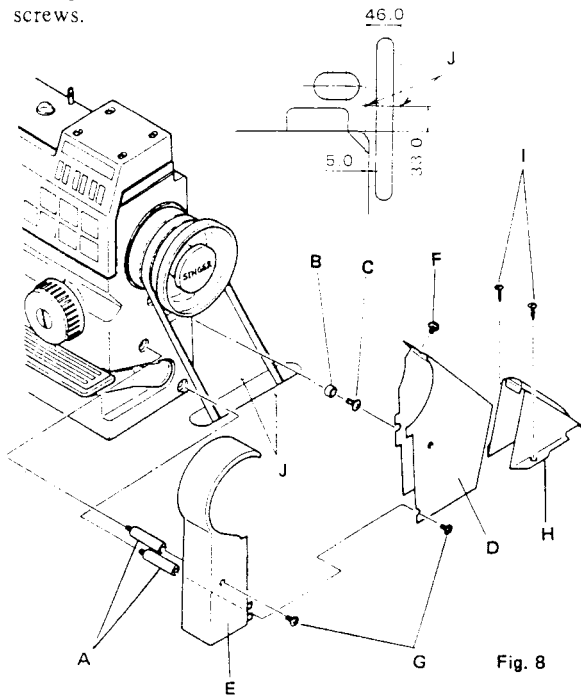

Fig. 8

TO REGULATE OIL SUPPLY TO SEWING HOOK

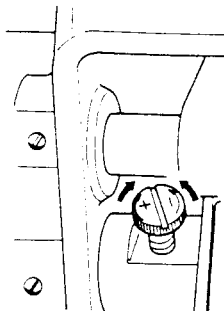

Fig. 9

Oil supply to sewing hook is regulated with the oil flow regulating screw in the rotating hook shaft bushing. (Fig. 9)

- For more oil, turn screw clockwise.
- For less oil, turn screw counterclockwise.

NEEDLE

The needle you use have a very direct effect on the quality, strength and appearance of the stitching produced by your machine. This is why it is so important to use SINGER needles according to the following chart.

Needles	
Catalog No.	Sizes
1955-01 (135 x 65)	8, 9, 10, 11, 12, 13, 14, 16, 17, 18, 19, 20, 21, 22, 23 and 24

Size of needle should be determined in accordance with the size of thread used and type of material being sewn. A correct size needle will permit the thread to pass freely through the eye of the needle and avoid strain and breaking. A bent needle will cause your machine to skip stitches. A hook or burr on the needle point will result in a finish that looks blurred and when short stitches are used the material may be cut.

TO SET THE NEEDLE

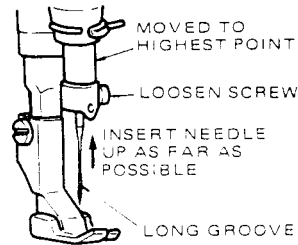

Fig. 10

- Turn machine pulley over toward you until the needle bar moves to its highest position.
- Loosen needle set screw as shown in Fig. 10.
- Insert needle up into needle bar as far as it will go with the long groove facing the left.
- Firmly tighten the needle set screw.

THREAD

In the class 691, use only left twist thread in the needle. Either right or left twist thread can be used in the bobbin. To determine the thread twist, hold the thread as shown in Fig. 11. Then roll the thread over toward you — if the strands of the thread wind tighter, the thread is left twist; if the strands unwind or separate, the thread is right twist.

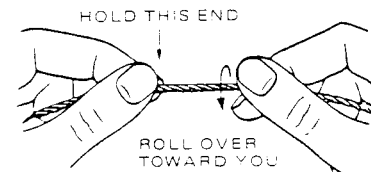

Fig. 11

TO REMOVE THE BOBBIN CASE

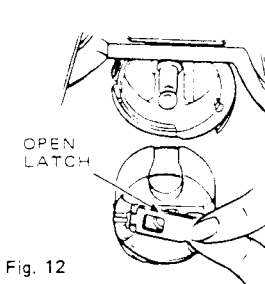

Fig. 12

- Turn machine pulley over toward you until the thread take-up lever is at its highest point.
- Reach beneath the bed of the machine with left hand and remove the bobbin case as shown in Fig. 12.
- To remove the bobbin from the bobbin case, release the latch, turn the open end of the bobbin case downward and the bobbin will drop out.

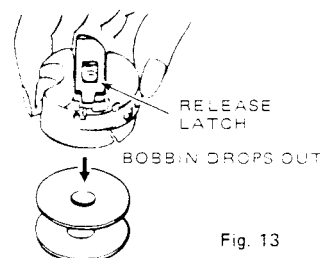

Fig. 13

NOTE: While the latch is kept open the bobbin will be retained in the bobbin case. (Fig. 13)

TO WIND THE BOBBIN

- Place bobbin on spindle **A** of bobbin winder, pushing it on as far as it will go and pass the thread from the left spool on the thread unwinder through threading points as shown in Fig. 14. Wind end of thread around the bobbin a few times and press latch **B** against the bobbin, then start the machine. The bobbin winder will stop automatically when bobbin is fully wound.
- To adjust the amount of thread on the bobbin, loosen screw **D** holding the adjusting plate **C** and move adjusting plate **C** toward **E** for less thread and toward **F** for more thread on the bobbin. Firmly tighten screw **D**.
- To regulate the tension, adjust knurled nut **G**.
- If thread winds unevenly on bobbin, loosen screw **H**, Fig. 15, and move bobbin winder tension **I** up or down as required, then tighten screw **H**.

NOTE:

To make above adjustment on 691D 150/250/350 machines, remove cover **J** shown in Fig. 16.

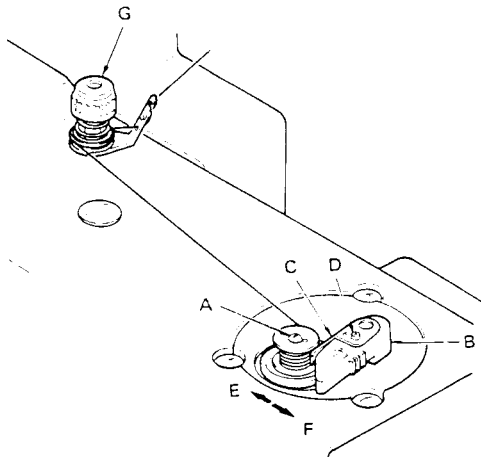

Fig. 14

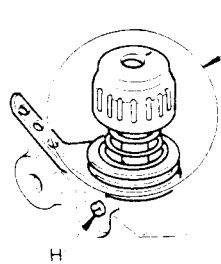

Fig. 15

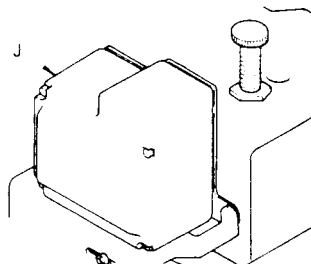

Fig. 16

TO THREAD THE BOBBIN CASE

SLOT NEAR TOP

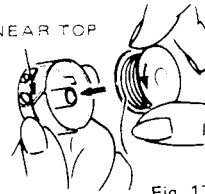
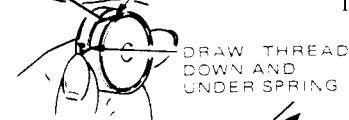

Fig. 17



PULL THREAD INTO SLOT



DRAW THREAD DOWN AND UNDER SPRING

Fig. 18



DRAW THREAD UP AND INTO DELIVERY EYE

Fig. 19

- Hold bobbin so that thread will unwind in the direction shown in Fig. 17, and insert bobbin in bobbin case.
- Pull thread into slot and under tension spring as shown in Fig. 18.
- Draw thread into delivery eye at end of tension spring as shown in Fig. 19.

TO REPLACE THE BOBBIN CASE

REPLACE BOBBIN CASE ON STUD

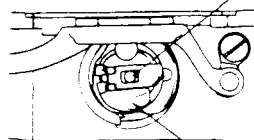

PRESS BOBBIN CASE FIRMLY INTO PLACE

Fig. 20

- Turn machine pulley over toward you until the needle bar moves to its highest position.
- Hold bobbin case by latch with left hand and place bobbin case on center stud of bobbin case holder. Release latch and press bobbin case firmly into place until latch catches groove near end of stud. Allow about 50 mm of thread to hang free. (Fig. 20)

TO REGULATE THE PRESSER FOOT PRESSURE

MORE PRESSURE LESS PRESSURE

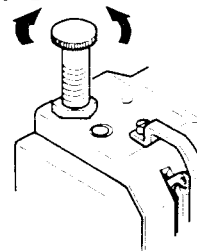

Fig. 21

Correct presser foot pressure helps feed the work properly. The pressure on the material should be as light as possible, while still sufficient to insure proper feeding.

- To increase pressure, turn thumb screw clockwise.
- To decrease pressure, turn thumb screw counterclockwise.

TO THREAD THE MACHINE

Turn machine pulley over toward you until needle is at its highest point, then pass the needle thread from the right spool on the unwinder through the threading point in the order shown in Figs. 22 through 26.

Thread the needle from left to right. Draw about 50mm of thread through eye of needle with which to commence sewing.

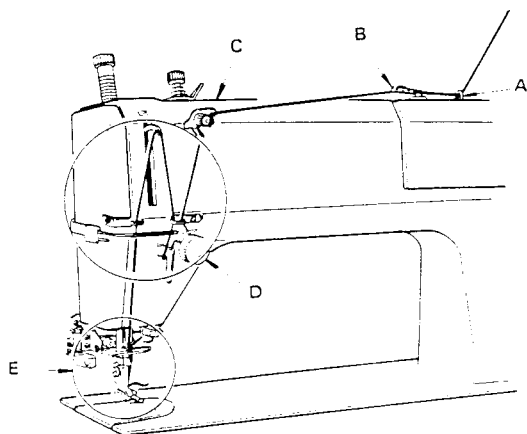
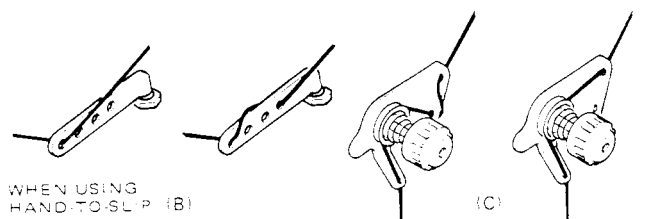

Fig. 22



WHEN USING
HAND-TO-SLIP (B)
THREAD

691D 100/110/200 691D 150/250/350
210/300/310

Fig. 23

Fig. 24

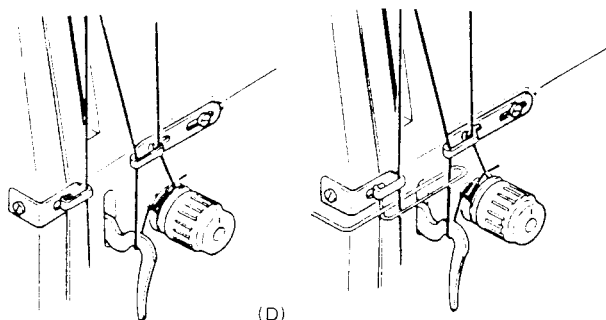

691D 100/110/200
210/300/310

691D 150/250/350

Fig. 25

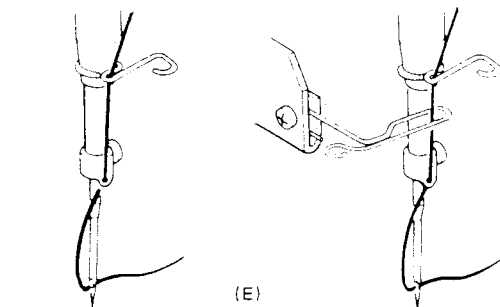

691D 100/110/200
210/300/310

691D 150/250/350

Fig. 26

PREPARING TO SEW

✧ With the 691D 100/110/200/210/300/310 machines, you can start sewing when the machines have been threaded and made ready to sew.

☆ When threading has been completed on the 691D 150/250/350 machines, push needle thread holder puller A downward in the direction B and clip end of needle thread in the thread holder C to release the tension discs D and swing slack needle thread regulator (upper) arm E to the left in the direction F as far as it will go to slacken the needle thread. Be sure to follow above procedure before starting to sew in order to avoid possible needle breakage and bending.

NOTE:

Above procedure should be followed also when needle thread is changed and when thread breaks during sewing, or when thread end is not caught by thread holder A at completion of sewing.

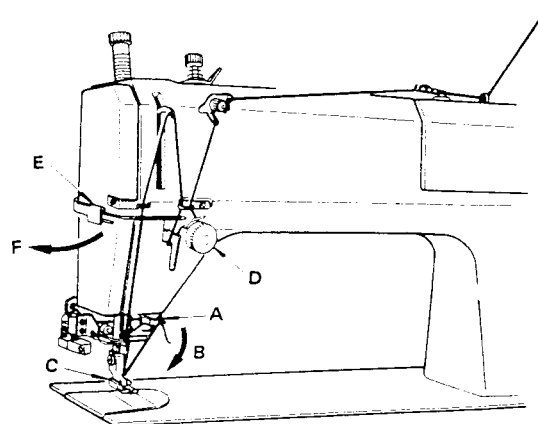

Fig. 27

TO OPERATE THE FOOT TREADLE

The foot treadle is operated in five steps as explained below and sewing speed can be readily controlled to desired speed by the amount of pressure applied on the treadle. (Fig. 28)

- ① For low speed sewing, depress the treadle lightly.
- ② For high speed sewing, depress the treadle all the way.
- ③ The machine will stop when treadle is returned to its neutral position.
- ④ The presser foot will rise when treadle is heeled lightly. (Will function only when machine is equipped with optional automatic foot lifter system)
- ⑤ The machine will stop after trimming the thread when treadle is heeled all the way.

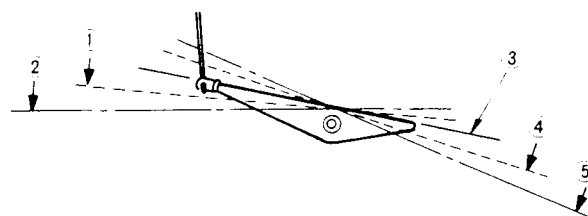

Fig. 28

- Quick heeling of the treadle from either high or low speed sewing will not affect the thread trimming performance.
- Once the trimmer starts its trimming cycle, it will complete the cycle even if the treadle is released to return to its neutral position, therefore, you need not continue to heel the treadle until thread trimming is completed.
- The treadle, even when depressed, will not start the machine for sewing immediately after it has been heeled for thread trimming. This is because the safety device provided in the control box checks the machine from being started until thread trimming cycle is completed.

TO ADJUST THREAD TENSIONS

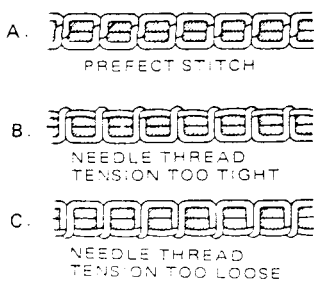

Fig. 29

- Normally, tension on the needle and bobbin threads should be balanced so that if you were to look at the cross section of a line of stitching, the needle and bobbin threads would be locked in the center of the thickness of the material as shown in Fig. 29-A.
- Incorrect settings will produce the conditions shown in Figs. 29-B and 29-C.

NEEDLE THREAD

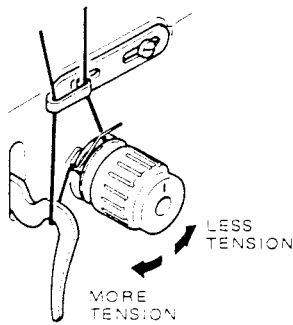

Fig. 30

- Regulate the needle thread tension only when the presser foot is down. Tension on the needle thread should be just enough to set the stitch properly in the material.
- Having lowered the presser foot, turn the thumb nut as instructed in Fig. 30.

BOBBIN THREAD

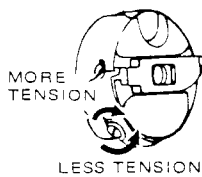

Fig. 31

- Once the tension on the bobbin thread has been properly adjusted, a correct stitch can usually be obtained by varying the tension on the needle thread only. For average sewing, the tension on the bobbin thread should be very light.
- To regulate the tension on the bobbin thread, remove the bobbin case and turn the screw in the tension spring as instructed in Fig. 31.

TO ADJUST THE TAKE-UP SPRING

The tension and the range of movement of the take-up spring A may require different settings depending upon the size of thread and material used. Heavier thread or material require more tension; delicate materials require less tension. Also the movement of take-up spring should be increased to ensure correct thread control.

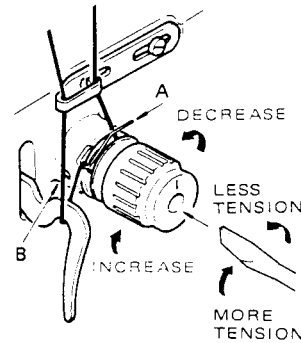

Fig. 32

- Using a large screwdriver in slot of tension stud, turn stud either over toward left to decrease tension, or over to right to increase tension as shown in Fig. 32.
- To set the take-up spring height, loosen screw B, Fig. 32, and turn entire tension assembly either over toward left to lower take-up spring and decrease its movement, or over toward right to raise take-up spring and increase its movement. Firmly tighten screw B.

TO ADJUST THE THREAD GUARD

To obtain perfectly locked stitches depending upon the thickness of material or the length of stitch, it may be necessary to adjust the thread guard A either to the left or to the right as shown in Fig. 33.

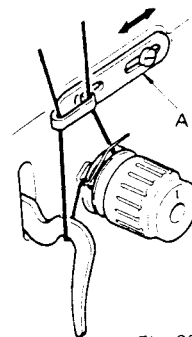

Fig. 33

- For heavy material or long stitches, move thread guard to the right.
- For lightweight material or short stitches, move thread guard to the left.

TO REGULATE THE STITCH LENGTH

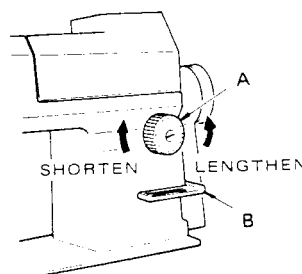

Fig. 34

- To regulate the length of stitch, turn feed regulating dial A to the left or right, as shown in Fig. 34.
- To change the direction of feed for manual back tacking, depress feed reverse lever B quickly to lowest position until back tack is completed.

Note: Although it may vary a little depending on the type of work being done, the numbers on the feed regulating dial indicate stitch length in millimeters.

TO ADJUST THE SLACK NEEDLE THREAD REGULATOR (UPPER) (691D 150/250/350)

Tightness of stitch at start of sewing can be controlled by regulating the slackness of needle thread with the slack needle thread regulator.

- Slide stop plate **A** in the direction **B** when bobbin thread is pulled up to top surface of the material at start of sewing due to insufficient slackness of the needle thread.
- Slide stop plate **A** in the direction **C** when needle thread is pulled down to underside of the material at start of sewing due to excess slackness of the needle thread.

NOTE:

When material, type and size of thread have been changed, or when stitch length has been changed, the slack needle thread regulator should be readjusted to draw proper amount of thread to provide correct slackness.

If slack needle thread regulator is not correctly adjusted for proper amount of slackness, it may result in needle thread being pulled out of needle eye at first two stitches, or skipped stitches and needle breakage.

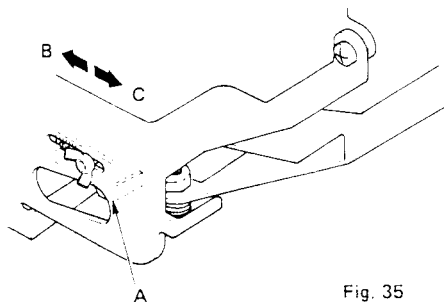

Fig. 35

TO ADJUST THE LENGTH OF NEEDLE THREAD END

The length of needle thread end should be adjusted so that the thread end will not be pulled out of needle eye, or show excessive bird nest on underside of the material at start of sewing.

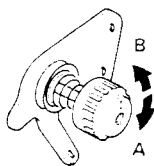

Fig. 36

- To shorten the length of thread end, turn pre-tension knob clockwise in the direction **A**. (Fig. 36)
- To lengthen the length of thread end, turn pre-tension knob counterclockwise in the direction **B**.

NEEDLE POSITIONING SWITCH

When needle positioning switch shown in Fig. 5 is set to $\frac{0}{-}$ and the treadle is returned to its neutral position during sewing, the machine will stop with the needle in the fabric and when set to $\frac{0}{+}$, the needle will stop in up position.

SOFT START SWITCH

When soft start switch shown in Fig. 5 is set to $\frac{1}{2}$, the machine will sew slowly for the first four stitches even when the treadle is fully depressed, making it possible to produce neatly finished stitches without needle thread end being pulled out of needle eye at start of sewing and also permit trimming the thread end as shortly as possible.

WIPER AND NEEDLE THREAD HOLDER

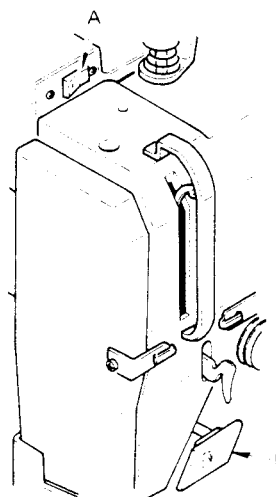

Fig. 37

☆ Wiper (691D 100/200/300)

- The wiper is very convenient for sewing operation such as sewing the needle thread end into the stitches on the underside of the fabric.
- Turn switch **A** off when wiper is not required for sewing operation. (Fig. 37)

☆ Needle thread holder (691D 150/250/350)

- The needle thread holder is very effective in preventing bird nesting on underside of the fabric at start of sewing.
- Turn switch **A** off when needle thread holder is not required for the type of sewing operation being done. (Fig. 37)

BACK TACK SWITCH

- When push plate **B**, Fig. 37 is pressed, the machine will immediately change from forward to reverse feed for back tacking and return to forward feed when released.
- During sewing operation, the machine will continue to sew in reverse while the push plate is pressed, however, when the machine is stopped, the protective circuit automatically cuts off the current supply to the solenoid after 12 seconds even when the push plate is pressed continuously.

TO ADJUST THE NEEDLE BAR HEIGHT

Turn machine pulley over toward you until the needle bar **A** moves to its lowest position. Remove rubber plug **B** from face plate and loosen screw **C** in needle bar connecting stud, (Fig. 38)

Taking care not to move the machine pulley, raise or lower needle bar so that timing mark **D** is level with the lower end of needle bar bushing **E**, Fig. 39, and tighten screw **C** after making sure the needle set screw is parallel with the front edge of the bed.

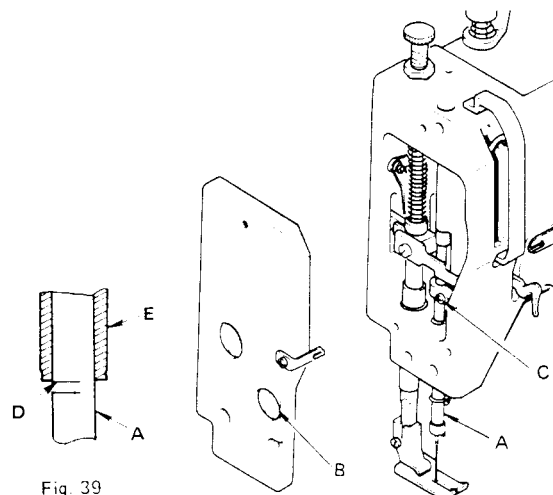

Fig. 39

Fig. 38

TO TIME THE SEWING HOOK IN RELATION TO THE NEEDLE

Loosen set screws **B** and **C** in sewing hook **A** just enough so that the sewing hook **A** can be turned on the shaft. Turn machine pulley over toward you until timing mark **E** on needle bar **D** is aligned with the end of needle bar bushing **F** on the upward stroke of the needle bar. (Fig. 40)

Hold shaft immovable and turn sewing hook **A** as required to bring hook point **G** to center of needle as shown in Fig. 41 and at the same time, adjust clearance between needle and hook point **G** to approximately 0.05mm as shown in Fig. 42. Tighten set screw lightly. Turn machine pulley to make certain the sewing hook is set correctly in relation to the needle, then firmly tighten set screw **C** and then the set screw **B**.

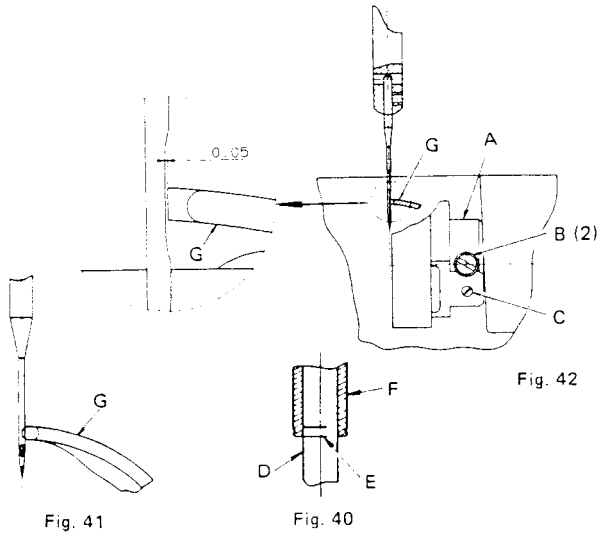

TO ADJUST THE FEED DOG HEIGHT

- Before the machine leaves the factory, the feed dog is set at appropriate height as shown below.
0.8mm – 691D 100/110/150/200/210/250
1.0mm – 691D 300/310/350

If it is necessary to adjust the feed dog height, loosen clamping screw **A** in feed lifting rock shaft crank (front), raise or lower the feed bar **F** as required, then firmly tighten screw **A**.

- The feed dog should be level at the top of its feed path. If adjustment is necessary, loosen screw **B** in feed bar carrier, insert screwdriver into access hole in end of bed and turn feed bar hinge pin **C** as required to level the feed dog. Then firmly tighten screw **B**.

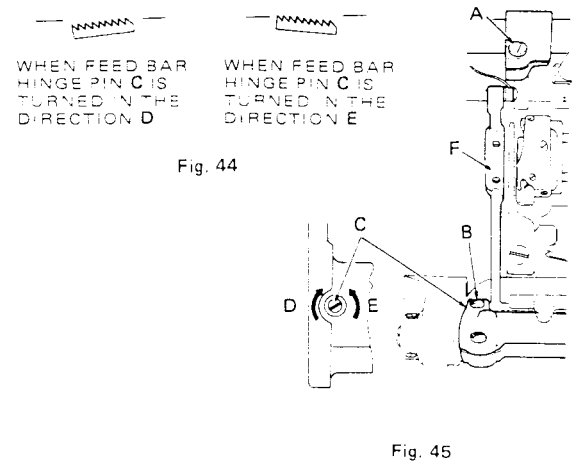

TO ADJUST THE PRESSER BAR HEIGHT

The height of presser bar when raised by hand should be:

- 7.2mm on 691D 100/110/150/200/210/250
- 6.0mm on 691D 300/310/350

To adjust the presser bar height, remove the rubber plug **A** in the face plate, loosen screw **B** in presser bar guide bracket **C** and raise or lower guide bracket **C**, as required, then firmly tighten screw **B** after making sure the presser foot is set parallel to the feed dog slots in the throat plate. (Fig. 43)

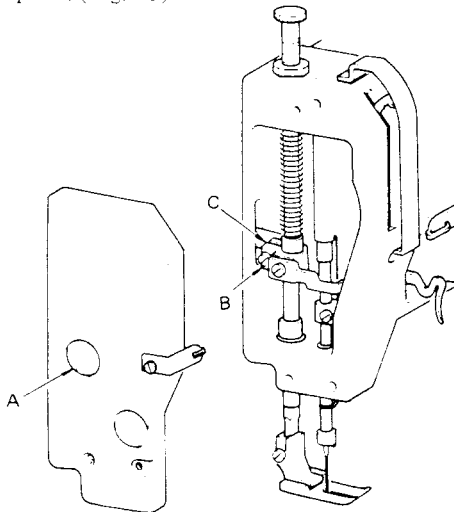

Fig. 43

TO TIME THE FEED

Before the machine leaves the factory, the timing mark on feed and feed lifting eccentric is set opposite to the longer timing mark on the arm shaft.

If for any reason it is necessary to alter the timing, loosen screw **A** in feed and feed lifting eccentric, turn eccentric as required taking every care not to move the eccentric in axial direction on the arm shaft, and firmly tighten screw **A**.

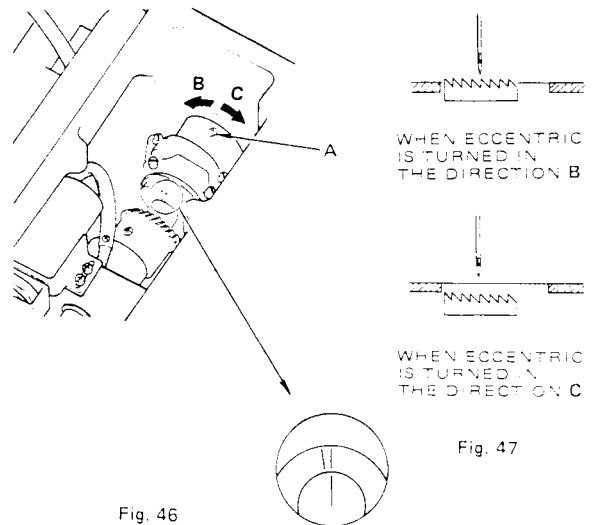

Fig. 46

Fig. 47

TO ADJUST THE NEEDLE POSITIONER

Before the machine leaves the factory, the needle positioner is set for normal sewing operation however, if adjustment is necessary, turn off power switch and adjust as instructed below after making sure the pilot lamp is out.

- ☆ To adjust the needle stop position (Up position after thread trimming)
 - Loosen screw **A**, Fig. 48.
 - Move screw **A** in slot as required, in the direction **D** for higher stop position and in the direction **C** for lower stop position. Firmly tighten screw **A**.
- ☆ To adjust the needle stop position (Down position)
 - Loosen screw **B**, Fig. 48.
 - Move screw **B** in as required.

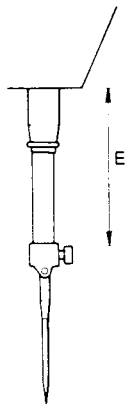

Fig. 49

Dimension of distance **E** at each stop position. (Fig. 49)

☆ Stop position UP after thread trimming

691D	100/110/150	... 25.5mm
	200/210/250	... 23.5mm
	300/310/350	... 18.5mm

☆ Stop position DOWN:

691D	100/110/150	... 47.2mm
	200/210/250	... 47.1mm
	300/310/350	... 47.7mm

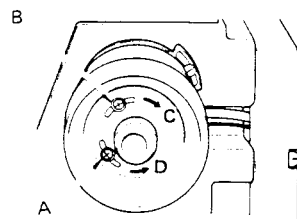

Fig. 48

TO ADJUST THE THREAD RETAINER

Should there be excessive bobbin thread spillage after thread trimming or when stitches can not be formed at start of sewing because of bobbin thread end being too short, adjust the pressure of thread retainer applied on the bobbin.

To adjust, loosen screw **A**, Fig. 50, and move thread retainer connecting rod **B** as required and tighten screw **A**. Push in trimmer solenoid plunger and check that thread retainer is pressing lightly against the bobbin.

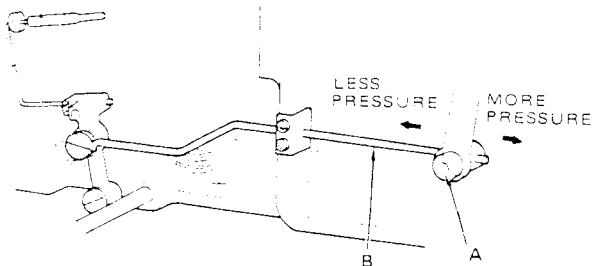

Fig. 50

TO ADJUST THE PRESSURE ON THE KNIFE

The pressure on the knife should be just enough to ensure clean cut. To adjust the pressure, loosen lock nut **A** and turn knife adjusting screw **B** to right or left as required, and firmly tighten the lock nut **A**.

NOTE:

The pressure of knife on the thread puller should be as light as possible. Excess pressure may result in damaging both the knife and the thread puller and also cause the machine to lock and insufficient pressure will result in mistrimming.

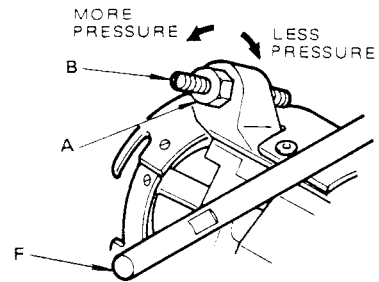

Fig. 51

TO REPLACE THE THREAD PULLER AND KNIFE

- ☆ To replace the thread puller (Figs. 52 and 53)
 - Tip machine back on its hinges and remove trimmer spring **A**.
 - Remove presser foot, throat plate and needle.
 - Move thread puller **B** to a position where the screws can be reached with a wrench.
 - Remove two screws **C** and replace the thread puller with a new one.
- ☆ To replace the knife (Figs. 51, 52 and 54)
 - Tip machine back on its hinges and remove trimmer spring **A**.
 - Remove bed leg (long) **F**.
 - Loosen knife adjusting screw **B**.
 - Move knife **D** to a position where the screws can be reached with a wrench.
 - Remove two screws **E** and replace the knife with a new one.

NOTE:

Replacement of thread puller and knife is done in the same manner as above except in reverse order.

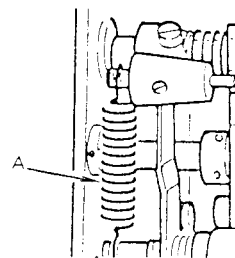

Fig. 52

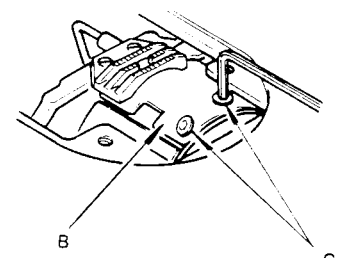

Fig. 53

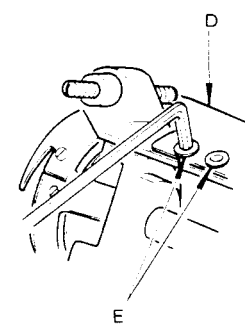

Fig. 54

TO ADJUST THE NEEDLE THREAD HOLDER PULLER SPRING (691D 150/250/350)

If thread holding strength of the needle thread holder puller is insufficient, adjust pressure of needle thread holder puller spring on needle thread holder puller.

- To adjust the pressure of needle thread holder puller springs **B, C** on puller **A**, loosen screws **D, E** and move springs **B, C** to the left or right as required. Firmly tighten screws **D, E**. (Fig. 55)

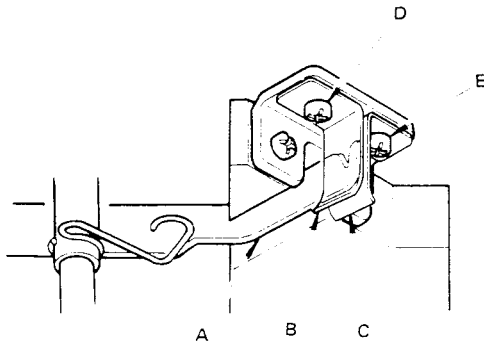

Fig. 55

TO ADJUST THE SLACK NEEDLE THREAD REGULATOR (LOWER) (691D 150/250/350)

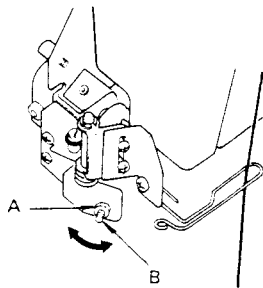

Fig. 56

For average sewing operation, the amount of movement of thread handling portion of the lower slack needle thread regulator should be set to about 1 to 2mm. To make this adjustment, loosen lock nut **A** and turn screw **B** as shown in Fig. 56.

MEMO

.....

.....

.....

.....

.....

.....

.....

.....

TO REPLACE THE PRESSER FOOT FIXED KNIFE (691D 150/250/350)

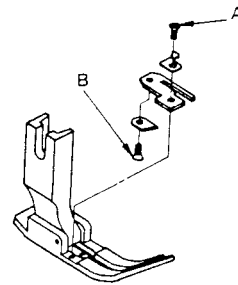

Fig. 57

- Remove presser foot from machine.
- Loosen set screw **A** in top of presser foot plate and remove thread guide and knife bracket from presser foot plate.
- Loosen set screw **B** in underside of knife bracket and remove the stationary knife.
- Fasten new stationary knife to knife bracket with set screw **B** then fasten knife bracket and thread guide to presser foot plate with set screw **A**.

NOTE:

Before changing the knife due to mistrimming, or when thread can not be cut cleanly, check and make sure there is no lint or dust accumulated around the knife and presser foot slot. If necessary, remove knife bracket and clean the area around the presser foot slot because accumulation of lint or dust may cause mistrimming or affect cutting quality.

CARING FOR YOUR MACHINE

How often you will need to clean and oil your machine will depend on how often you will use it. When in regular use, the machine should be cleaned and oiled periodically. A machine in frequent use should be cleaned and oiled more frequently.

- Remove throat plate and remove dust and lint from around the feed dog, rotating hook, trimmer and area around the thread puller.
- Remove lint from oil reservoir and also from screen on oil pump.
- On 691D150/250/350 machines, remove the knife bracket fixed to presser foot and clean lints and dusts accumulated around the presser foot slot.

CAUTION:

Before cleaning the machine, turn off the power switch.

SPECIFICATIONS

Machine	100GG	110GG	150GG	200GG	210GG	250GG	300GG	310GG	350GG
Equipped with	Wiper		Needle Thread Holder	Wiper		Needle Thread Holder	Wiper		Needle Thread Holder
For sewing	Light Weight			Light to Medium Weight			Medium to Heavy Weight		
Maximum speed	5,500 s. p. m.						5,000 s. p. m.		
Trimming speed	200 s. p. m.								
Max. stitch length	5.0mm								
Needle bar stroke	29.2 mm			30.6 mm			36.5 mm		
Presser bar lift (by hand)	7.2 mm						6.0 mm		
Presser bar life (by knee)	12.7 mm								
Needle	Catalog No. 1955-01 #14						Catalog No. 1955-01 #16		
Sewing hook	Horizontal axis rotating hook (with lubrication system)								
Bobbin case	P/N 540735 with anti spill spring								
Bobbin	Steel or aluminum								
Thread trimmer	Clam shell type								
Trimmer driving system	Solenoid and cam controlled								
Tension releasing system	Solenoid controlled								
Back tack	Solenoid controlled automatic backtack								
Lubrication system	Fully automatic lubrication system								
Oil return system	Plunger pump type oil return system								
Oil	SINGER Type "C" Oil								
Bed size	476 x 178 mm								
Motor	AC Servo type needle positioner motor								

NOTE: The machine should be operated at a speed slower than the maximum recommended speed depending on the material being sewn and the type of work being done.

*To ensure that you are always provided with the most modern sewing capabilities, the manufacturer reserves the right to change the appearance, design or accessories of this sewing machine when considered necessary without notification or obligation.

