ADJUSTERS MANUAL

FOR

SINGER*

SEWING MACHINE

600w1

HIGH SPEED

LOCK STITCH

Single Rotary Thread Take-up

THE SINGER MANUFACTURING COMPANY

FOREWORD

This book contains complete information covering operation, adjustment, parts list, attachments and special fittings for Machine 600W1. Descriptions and exploded views of all parts assemblies on pages 33 to 53, inclusive, will be found helpful when ordering any part of the machine requiring renewal.

DESCRIPTION

Machine 600W1, for stitching light and medium weight fabrics, has the following characteristics:

Single Needle, Lock Stitch.

Single Rotary Thread Take-up.

Belt Driven, Automatically Lubricated Rotary Sewing Hook on a Horizontal Axis.

Drop Feed.

Maximum Length of Stitch 5-1/2 to the inch.

Presser Bar Lift 9/32 inch.

Needle Bar Stroke 1-9/64 inches.

Machine Pulley with outside diameter of belt groove 2.90 inches for 3/8 inch "V" Belt. Effective diameter for 5/16 inch round leather belt is 2-3/8 inches.

Ball Bearings for both ends of arm shaft and pulley end of hook driving shaft.

Needle Bearings for Needle Bar Connecting Link and Feed Driving and Lifting Connections.

Bed 15-11/16 inches long, 7 inches wide.

Space at right of needle 8 inches.

SPEED

The maximum speed recommended for this machine is 5000 R.P.M. It is advisable to run a new machine slower than the maximum speed for the first few minutes to allow time for the oil to reach the moving parts. The top of the machine pulley turns over from the operator.

THREAD

Left twist thread should be used in the needle. Either right or left twist thread can be used in the bobbin.

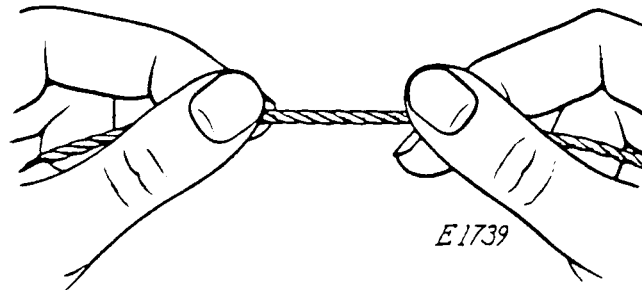

Fig. 4. How to Determine the Twist

Hold the thread as shown above. Turn the thread over toward you between the thumb and forefinger of the right hand; if left twist, the strands will wind tighter; if right twist, the strands will unwind.

TO REMOVE THE BOBBIN

Turn the machine pulley over from you until the needle moves up to its highest position. Draw back the slide in the bed of the machine. Reach under the table and open the bobbin case latch **E**, Fig. 5 and, by means of this latch, remove the bobbin case from the sewing hook.

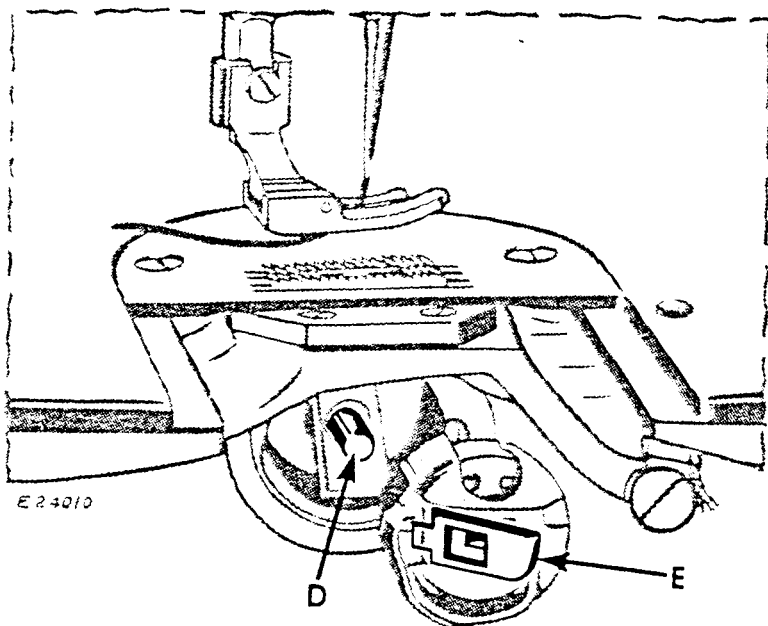

Fig. 5. Removing the Bobbin

While the latch remains open, the bobbin will be retained in the bobbin case. Release the latch, turn the open end of the bobbin case downward and the bobbin will drop out.

TO WIND THE BOBBIN

Fasten the bobbin winder to the table with its driving pulley in front of the machine belt, so that the pulley will drop away from the belt when sufficient thread has been wound upon the bobbin.

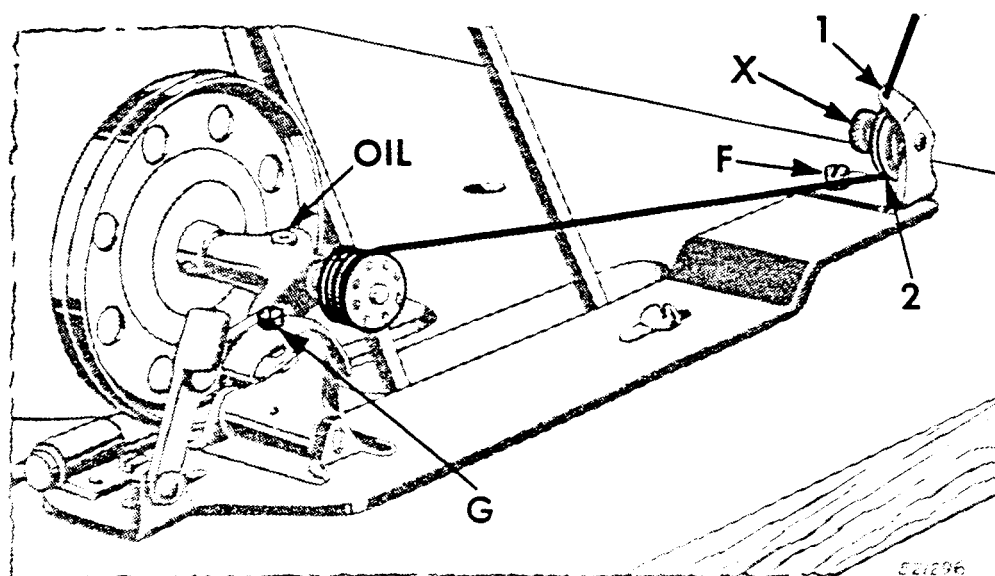

Fig. 6. Winding the Bobbin

Place the bobbin on the bobbin winder spindle and push it on as far as it will go.

Pass the thread down through the thread guide 1 in the tension bracket, around the back of, and between, the tension discs 2. Then wind the end of the thread around the bobbin a few times in the direction shown in Fig. 6, push the bobbin winder pulley over against the machine belt and start the machine.

When sufficient thread has been wound upon the bobbin, the bobbin winder will stop automatically.

If the thread does not wind evenly on the bobbin, loosen the screw F in the tension bracket and move the bracket to the right or left as may be required, then tighten the screw.

The amount of thread wound on the bobbin is regulated by the screw G. To wind more thread on the bobbin, turn the screw G inwardly. To wind less thread on the bobbin, turn this screw outwardly.

Bobbins can be wound while the machine is stitching.

When winding a bobbin with fine thread, a light tension should be used. Adjust the knurled nut X, Fig. 6, to regulate the tension.

TO THREAD THE BOBBIN CASE

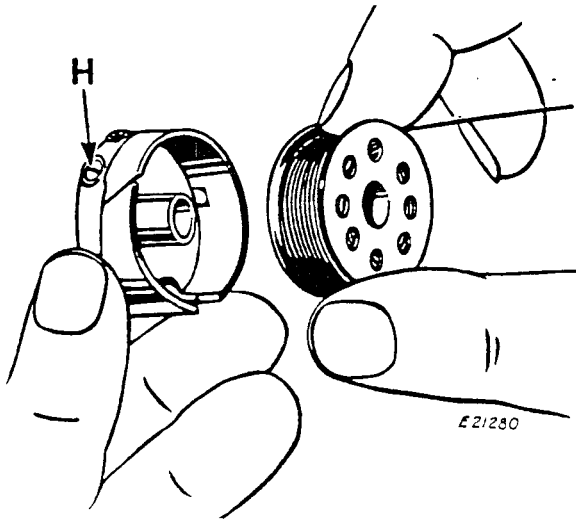

Fig. 7

Hold the bobbin between the thumb and forefinger of the right hand, as shown in **Fig. 7**, the thread drawing on the top from the left toward the right.

With the left hand hold the bobbin case as shown in **Fig. 7**, the slot in the edge being near the top, and place the bobbin into it.

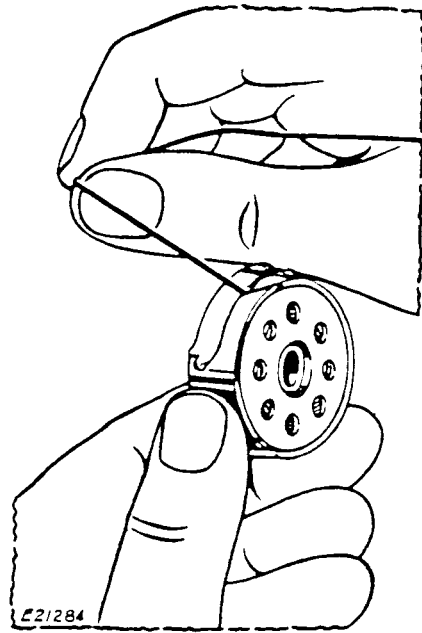

Fig. 8

Then pull the thread into the slot in the edge of the bobbin case as shown in **Fig. 8**; draw the thread under the tension spring and into the delivery eye at the end of the tension spring. See **Fig. 9**.

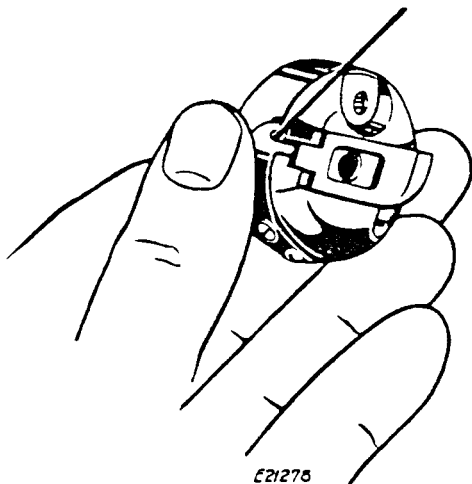

Fig. 9

TO REPLACE THE BOBBIN CASE

After threading, take the bobbin case by the latch and place the bobbin case on the center stud **D**, **Fig. 5** of the bobbin case holder; release the latch and press the bobbin case back until the

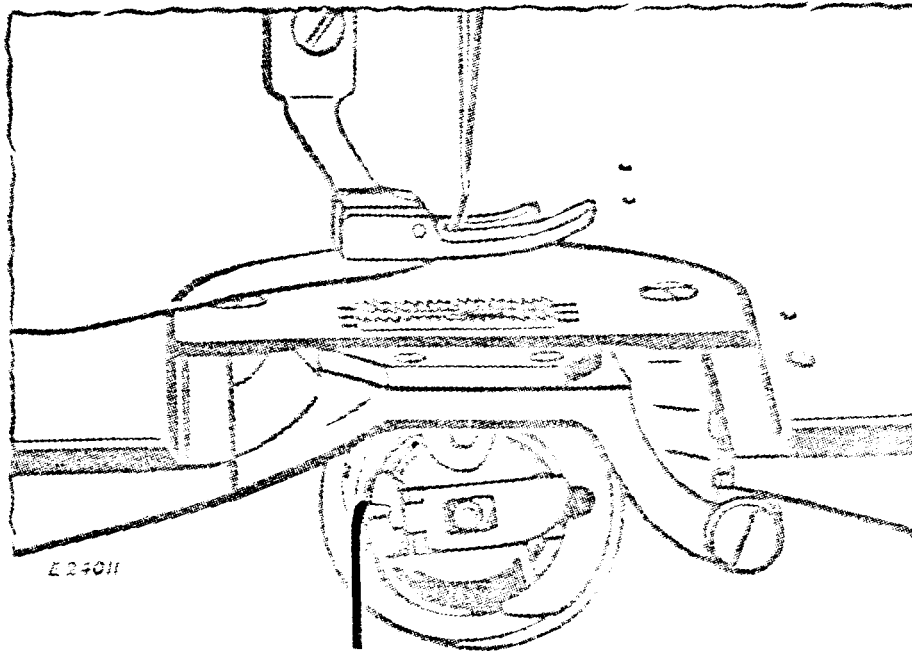

Fig. 10. Bobbin Case Threaded and Replaced

latch catches the groove near the end of the stud. See **Fig. 10**. Allow about two inches of thread to hang free, and replace the slide in the bed of the machine.

TO SET THE NEEDLE

Turn the machine pulley over from you until the needle bar moves up to its highest point; loosen the screw at the lower end of the needle bar and put the needle up into the bar or clamp as far as it will go, with the long groove of the needle toward the left and the eye of the needle directly in line with the arm of the machine, then tighten the screw.

UPPER THREADING

See Fig. 11

When you have become accustomed to threading the machine, the thread can be passed from the thread retainer J at the top, down to the needle with a single continuous motion.

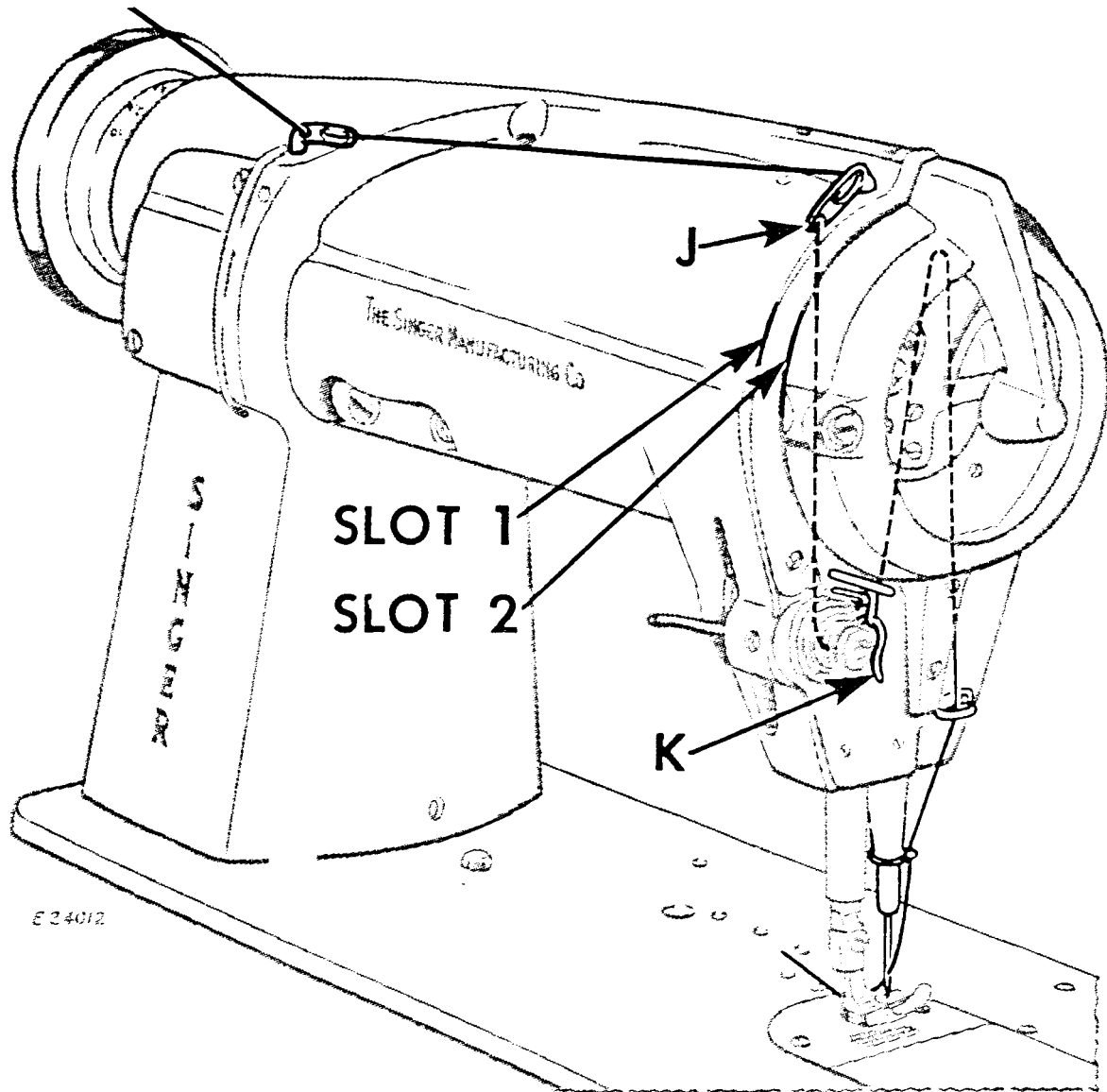

Fig. 11. Rear View of Machine, Showing Upper Threading

Pass the thread through the threading points in the manner shown in **Fig. 11**. Hold the thread with the right hand near the thread retainer J while passing the thread, with the left hand, downward into the inner slot 1 and on down around and between the tension discs, into the take-up spring and under the thread pull-off K, then over through the slot 2, allowing the thread to fall in place over the take-up disc, as shown in **Fig. 11**, then release the thread with the right hand and continue to pass it down through the two thread guides and from left to right through the eye of the needle. Leave about three inches of thread with which to commence sewing.

TO PREPARE FOR SEWING

With the left hand hold the end of the needle thread, leaving it slack from the hand to the needle, turn the machine pulley over from you until the needle moves down and up again to its highest

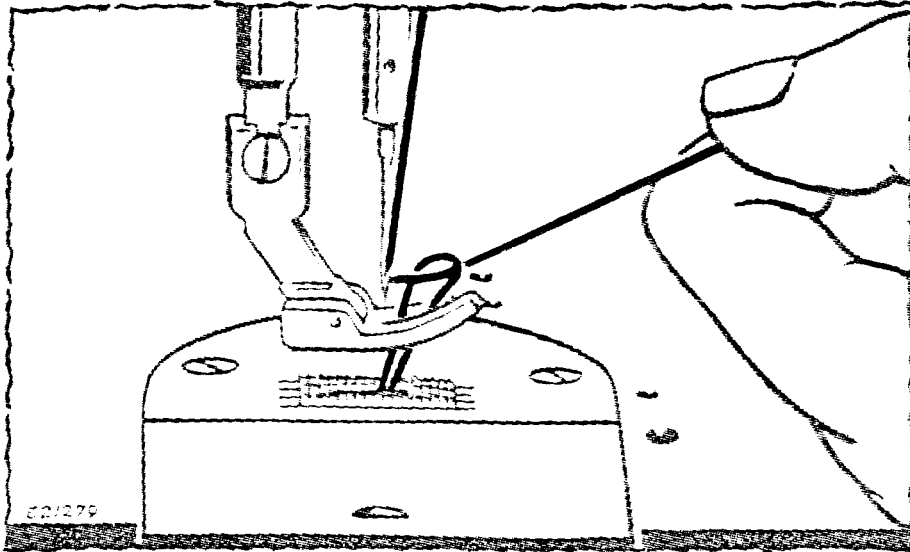

Fig. 12. Drawing Up the Bobbin Thread

point, thus catching the bobbin thread; draw up the needle thread and the bobbin thread will come up with it through the hole in the throat plate. See Fig. 12. Lay both threads back under the presser foot.

TO COMMENCE SEWING

Place the material beneath the presser foot, lower the presser foot and commence to sew.

TO REMOVE THE WORK

Stop the machine when the needle bar has just started to descend. In this position the upper thread will be free of the sewing hook and the take-up will not unthread the needle when the machine is started. Raise the presser foot, draw the work back and cut the threads close to the work.

TO REMOVE BROKEN THREAD FROM TAKE-UP

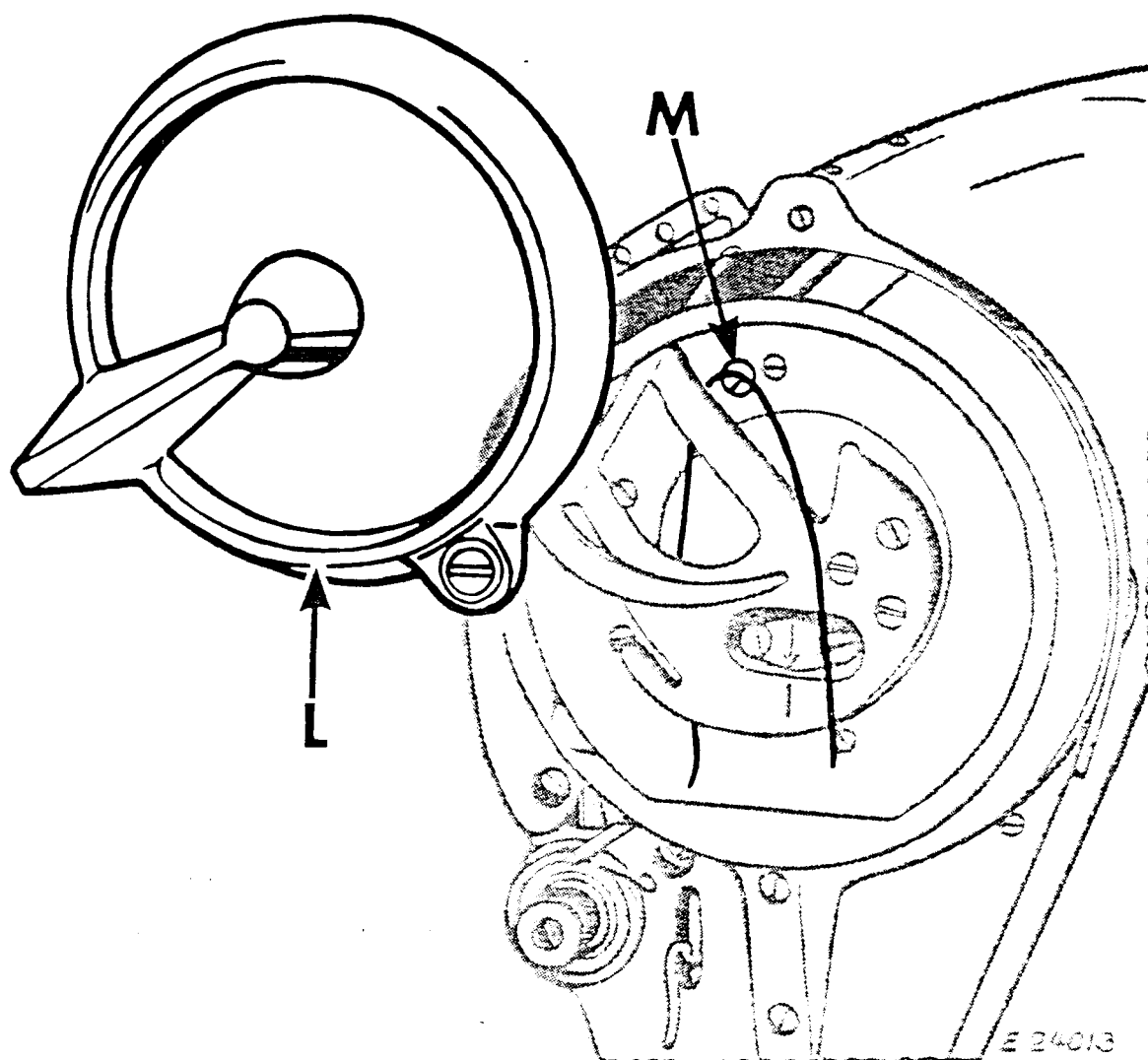

Fig. 13. To Remove Broken Thread from Rotary Take-up

If the thread breaks at operating speeds, an extra piece of thread may be found in the take-up which is visible through cover **L**. Open the cover and remove the thread, then close the cover and rethread.

CAUTION: When removing end of thread from the take-up, be careful not to cut fingers on the thread cutter **M**.

If no end of thread is visible around the take-up, just rethread and proceed to sew.

TENSIONS

For ordinary stitching, the needle and bobbin threads should be locked in the center of the thickness of the material, thus:



Fig. 14. Perfect Stitch

If the tension on the needle thread is too tight, or if that on the bobbin thread is too loose, the needle thread will lie straight along the upper surface of the material, thus:

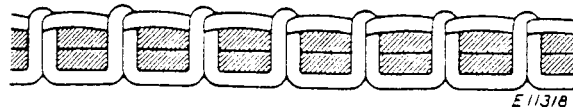

Fig. 15. Tight Needle Thread Tension

If the tension on the bobbin thread is too tight, or if that on the needle thread is too loose, the bobbin thread will lie straight along the under side of the material, thus:

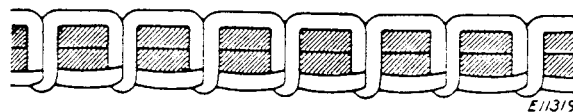

Fig. 16. Loose Needle Thread Tension

TO REGULATE THE TENSIONS

THE TENSION ON THE NEEDLE THREAD SHOULD BE REGULATED ONLY WHEN THE PRESSER FOOT IS DOWN. Having lowered the presser foot, turn the small thumb nut at the front of the tension discs over to the right to increase the tension. To decrease the tension, turn this thumb nut over to the left.

The tension on the bobbin thread is regulated by the large screw **H**, Fig. 7 in the tension spring on the outside of the bobbin case. To increase the tension, turn this screw over to the right. To decrease the tension, turn this screw over to the left.

When the tension on the bobbin thread has been once properly adjusted, it is seldom necessary to change it, as a correct stitch can usually be obtained by varying the tension on the needle thread.

TO REGULATE THE PRESSURE ON THE MATERIAL

The pressure of the presser foot on the material is regulated by the screw **N**, **Fig. 17** in the top of the arm. Turn this screw downward, **clockwise**, to increase the pressure or upward, **counter-clockwise**, to decrease the pressure. The pressure should be set only sufficiently strong to satisfactorily feed the work.

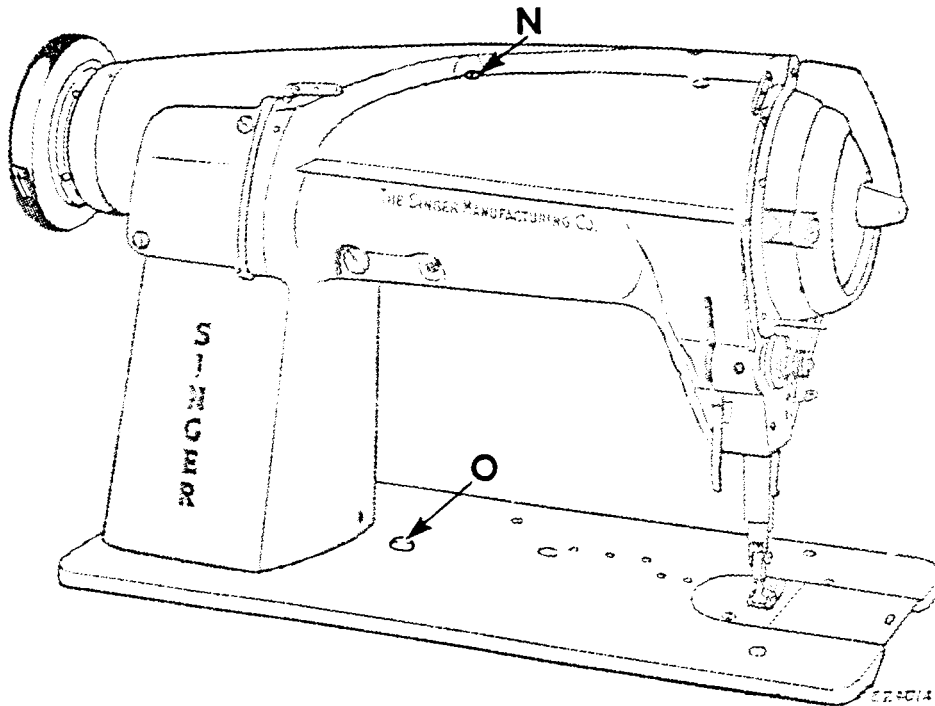

Fig. 17. Screw **N** for Regulating Pressure on Presser Foot and Stud **O** for Regulating Length of Stitch

TO REGULATE THE LENGTH OF STITCH

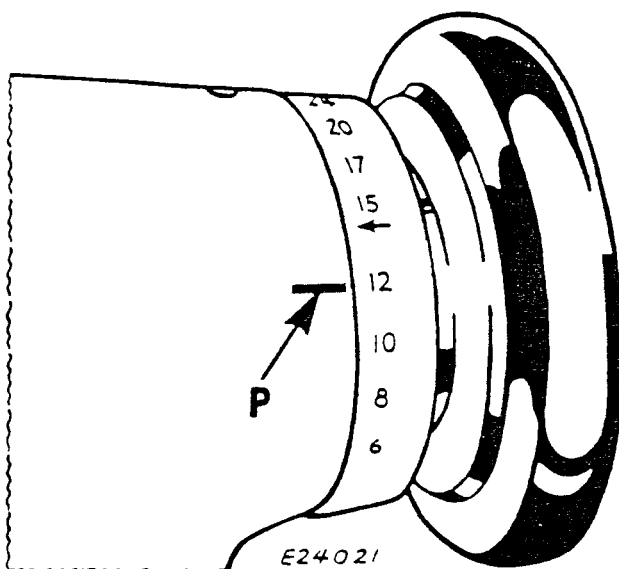

Fig. 18. Stitch Indicator

To change the length of stitch, press down the stud **O**, **Fig. 17** in the bed of the machine and at the same time turn the machine pulley slowly over from you until the stud enters a notch in the adjustable feed eccentric cam on the bed shaft. Still holding the stud, turn the machine pulley until the number indicating the number of stitches per inch desired is opposite the mark **P**, **Fig. 18**, then release the stud. **DO NOT TOUCH THE STUD **O** WHILE THE MACHINE IS RUNNING.**

HINTS FOR PERFECT OPERATION

Follow instructions and oil machine regularly.

The machine pulley must always turn away from the operator.

Do not run machine with bobbin case only partly inserted.

Do not run the machine with the presser foot resting on the feed without cloth under the presser foot.

Do not run the machine when both bobbin case and needle are threaded unless there is material under the presser foot.

Do not try to help the machine by pulling the fabric lest you bend the needle. The machine feeds the work without assistance.

The slide over the bobbin case should be kept closed when the machine is in operation.

Do not press on the knee lifter lever while the machine is in operation, as this will prevent the work from feeding properly.

Occasionally remove the accumulation of lint from around the hook and from between the feed rows beneath the throat plate.

NEVER TOUCH THE STITCH REGULATOR STUD WHEN THE MACHINE IS RUNNING.

Never run machine with the take-up cover open.

TIMING THE MACHINE

The parts are in their proper timing on the various shafts when the locating screws are in the shaft splines provided for them. These locating screws are the first screws appearing when the shafts are revolved in their normal direction of rotation and are provided with a cone shaped point.

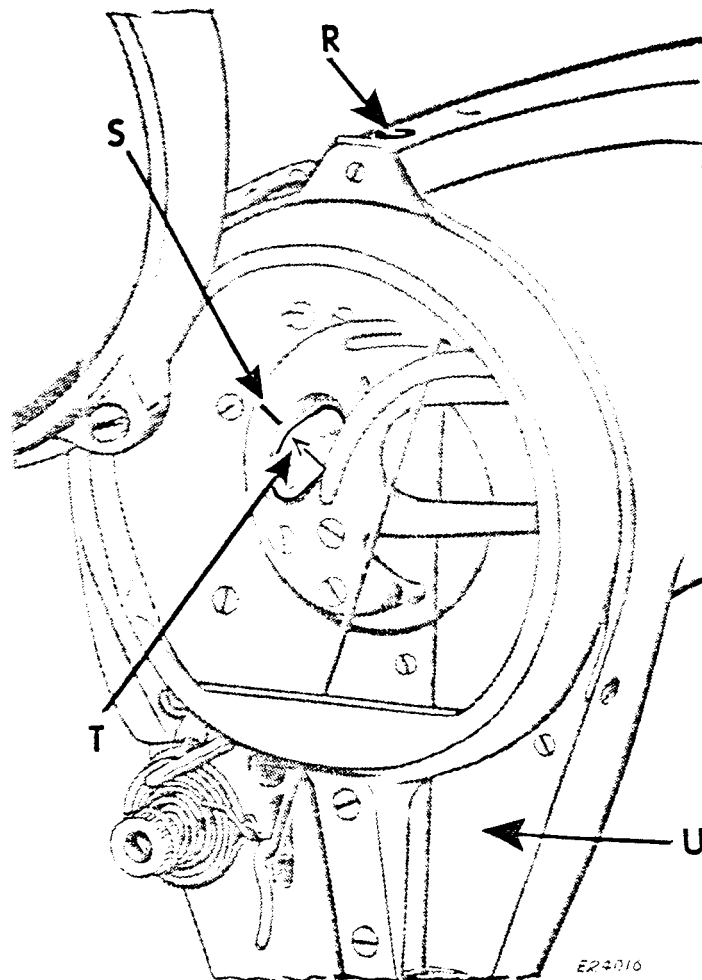

Fig. 19. Showing Timing Marks on Take-up and Take-up Clamping Plate

For normal sewing, the rotary thread take-up is correctly timed when the timing mark **S**, Fig. 19 on the take-up is in line with the arrow **T**, Fig. 19 on the clamping plate.

Some types of thread and materials, may require a slightly different timing of the take-up than that described above. To **advance** the take-up, loosen the two screws in the clamping plate **T** and move the take-up **S** **counterclockwise**. To **retard** the take-up, move it **clockwise**. After timing the take-up, securely tighten the two screws in the clamping plate **T**.

The needle bar and sewing hook are timed as described on page 20.

TO ADJUST THE THREAD TAKE-UP SPRING

The thread take-up spring **X**, **Fig. 20** should have just enough movement so that it will be through acting and will rest against the upper end of the spring regulator **V**, **Fig. 20** when the point of the needle reaches the throat plate on the downward stroke of the needle bar. After loosening the set screw **Y**, **Fig. 20**, the tension will turn with the stud **W**, **Fig. 20** and the spring regulator may be turned to the required position, then tighten the set screw **Y**.

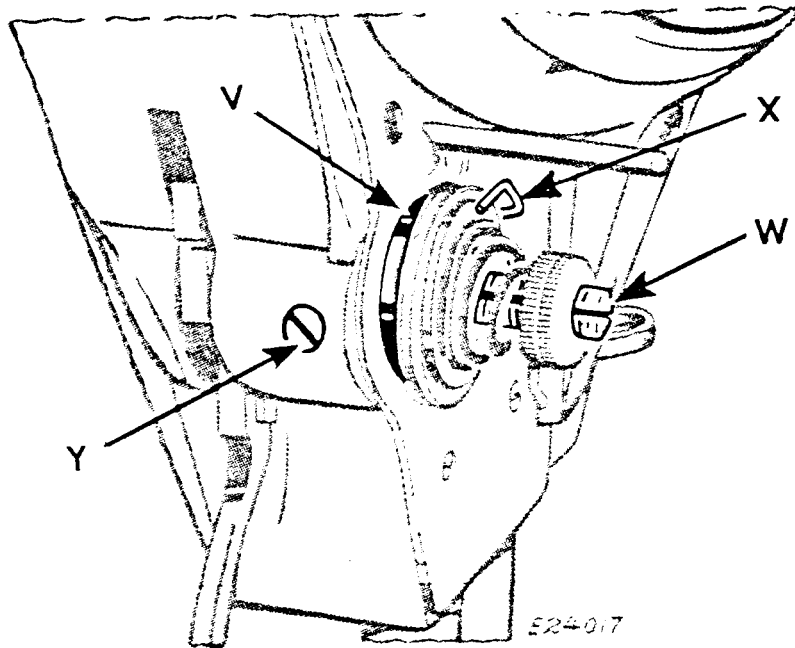

Fig. 20. Take-up Spring Adjustments

The tension on the thread take-up spring **X** is regulated by turning the tension stud **W**, **Fig. 20** to the left to increase the tension, or to the right to decrease the tension. The tension on the thread take-up spring should be just sufficient to take up the slack of the needle thread until the point of the needle reaches the throat plate on the downward stroke of the needle bar.

PRESSER BAR ADJUSTMENTS

The presser bar bushing **A2**, Fig. 21 should be set so that its top is even with the top of the lifting bracket **B2**, Fig. 21 when the bracket is all the way down.

The presser bar position guide **C2**, Fig. 21 should be set about 1/16 inch above the top of the lifting bracket **B2** when the presser foot is down on the throat plate. This setting should leave 1/16 inch clearance between casting and presser bar position guide **C2**.

With the feed dog and presser foot down, there should be a slight free motion in the hand lifter lever so that the presser foot will rest on the work during operation of the machine.

To align the presser foot with the needle, have the presser foot down on the throat plate, loosen the screw **D2**, Fig. 21, turn the presser foot to the desired position and retighten the screw **D2**.

The spring **P3**, Fig. 37, between the bed casting and collar **O3**, Fig. 37, on the knee lifter lifting rod cushions the action of the lifting bracket.

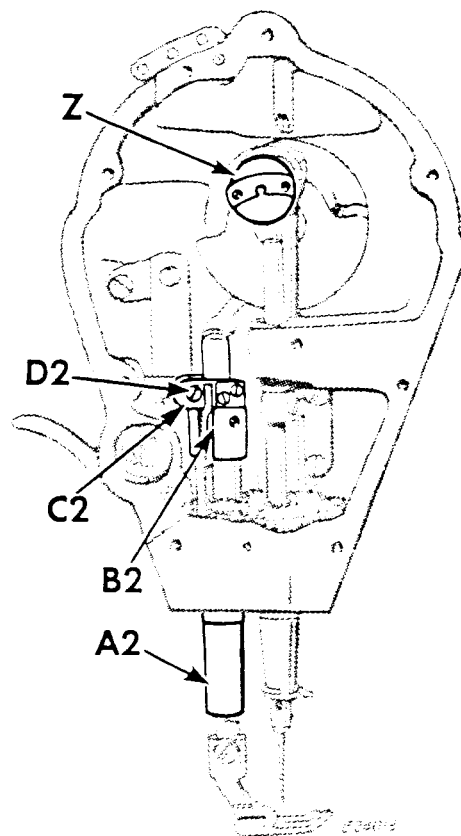

Fig. 21. Face Plate Removed

ADJUSTMENT OF THE TENSION RELEASER

The tension releaser **J2**, Fig. 22 automatically releases the spring pressure on the tension discs when the presser bar is raised. The releaser may be moved up or down to release the tension earlier or later, by loosening the screw **K2**, Fig. 22.

When stitching on heavy material, the releaser should be set lower than when on light work to prevent stitching with a released tension while sewing heavy material.

TO SET THE NEEDLE BAR AT THE CORRECT HEIGHT

When the needle bar is at its highest position, the lower timing mark **H2**, Fig. 22 on the needle bar should be just visible at the lower end of the needle bar bushing **F2**, Fig. 22. If the needle bar is not correctly set, loosen the screw **E2**, Fig. 22 in the needle bar connecting stud and move the needle bar to the correct position.

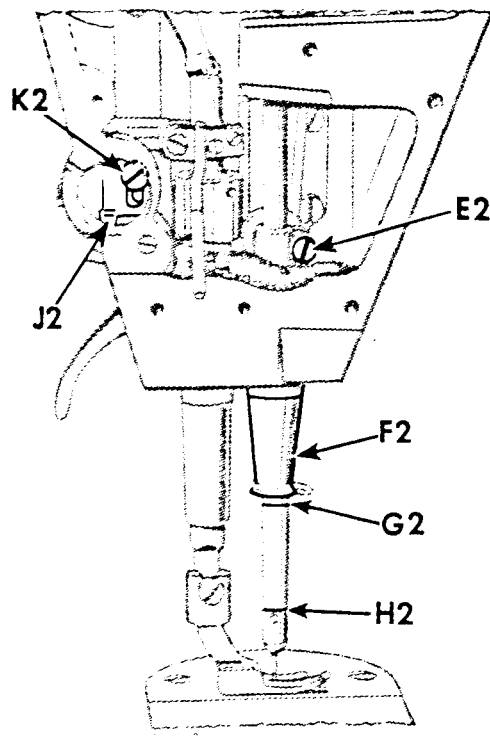

Fig. 22. Setting Needle Bar

TO SET NEEDLE BAR AT THE CORRECT HEIGHT IF NEEDLE BAR BUSHING SETTING HAS BEEN DISTURBED

Set the needle bar when at the bottom of its stroke so that the eye of the needle is above the needle guard of the bobbin case holder just enough to allow freedom for the thread, as shown in Fig. 25. Then with the needle at its highest position, the bushing can be reset by driving it so that the lower timing mark **H2**, Fig. 22 on the needle bar is just visible at the lower end of the bushing.

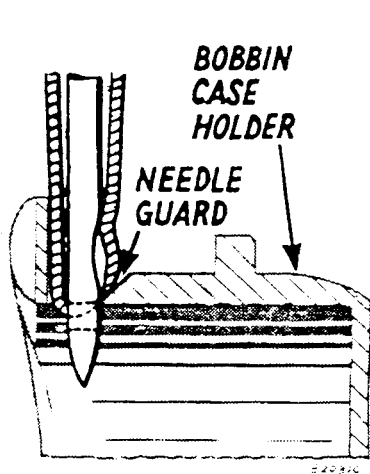

Fig. 23
Needle Too Low When
At Bottom of Stroke

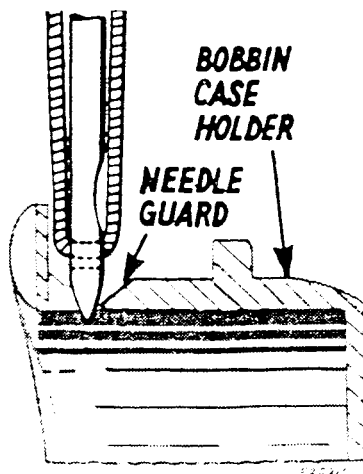

Fig. 24
Needle Too High When
At Bottom of Stroke

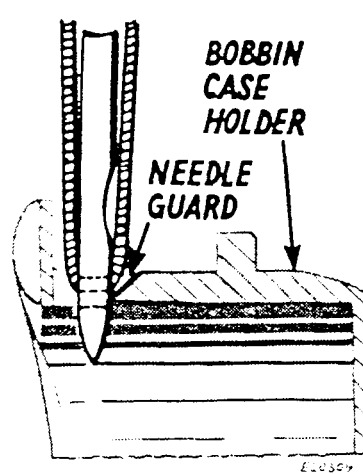

Fig. 25
Correct Height of
Needle When At
Bottom of Stroke

Turn top of machine pulley over from you until the needle has risen .085 inch (approximately 1/12 inch) from its lowest position. In this position, the hook timing mark **O** on the machine pulley will be in line with the mark **P**, Fig. 27 on the arm casting. Then set the hook so that its point is at the center of the needle and positioned as described on page 20.

TIMING THE SEWING HOOK

First see that the needle bar is correctly set as instructed on **page 19**. Remove presser foot, slide plate, throat plate, bobbin case, feed dog and bobbin case holder position finger. Rotate the bobbin case holder about one-half turn so that it is clear of the needle.

To determine whether the hook is correctly timed, place a new needle in the machine, then turn the top of the machine pulley over from you until the needle bar has started to rise from its lowest position and the upper timing mark **G2, Fig. 22**, is just visible at the lower end of the needle bar bushing **F2, Fig. 22**. In

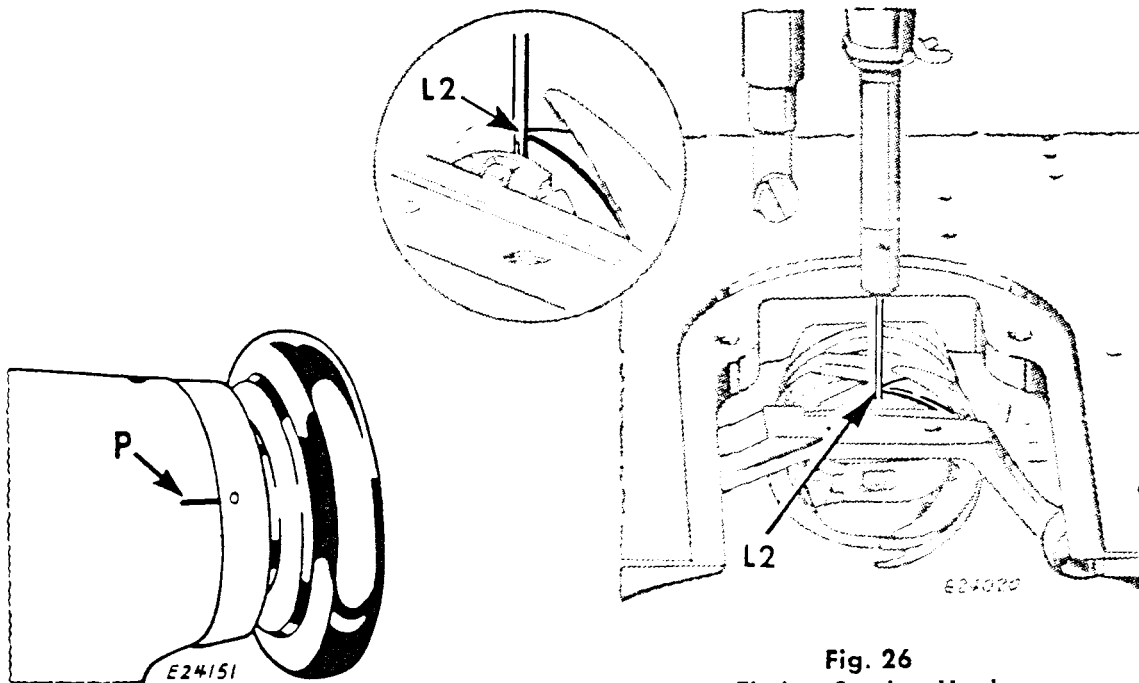

Fig. 27. Showing Timing Mark on Machine Pulley

**Fig. 26
Timing Sewing Hook**

this position, the hook timing mark **O** on the machine pulley will be in line with the mark **P, Fig. 27** on the arm casting and the point of the sewing hook should be at the center of the needle, as shown at **L2, Fig. 26**.

If the hook time is incorrect, loosen the two screws **M2, Fig. 32** in the hub of the hook and turn the hook on its shaft to bring into correct timing.

The point of the hook should pass the needle as closely as possible without actually touching it. This is equal to about the thickness of a piece of ordinary note paper. The hook should be placed on the shaft as far as it will go. If it is necessary to move the hook sidewise, loosen the set screw **O2, Fig. 32**, and move the bushing **N2, Fig. 32**, with the hook assembly as required, tapping it to the right or prying it to the left with a screwdriver against the bed casting.

TO DETERMINE CORRECT RELATIONSHIP OF NEEDLE GUARD TO NEEDLE

The function of the needle guard Fig. 28 of the bobbin case holder is to prevent the hook point from coming into contact with the needle at loop-taking time in case the needle is deflected side-

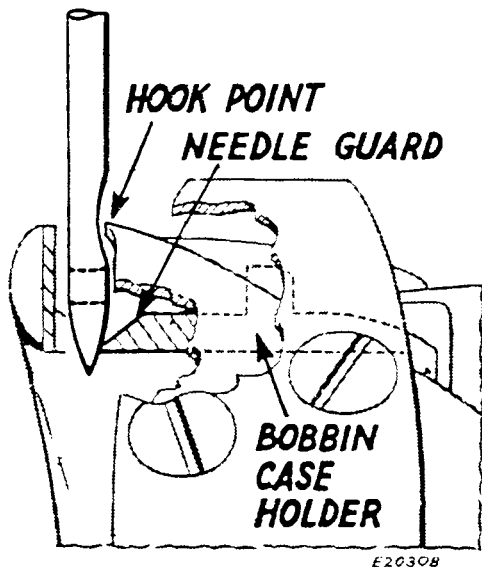

Fig. 28. Showing Correct Relationship of Needle Guard and Sewing Hook Point to Needle at Loop-taking Time

wise toward the hook point. (However, it will, at this time, cause little or no deflection of the needle, as shown in Fig. 28). When the needle guard is correctly related to the needle, it will deflect the needle slightly to the left as the needle approaches its lowest position.

It will sometimes be necessary to string the needle guard, as shown in Fig. 30, to provide additional clearance for the needle. Before doing this, the machine should be properly adjusted as previously described. Check the settings in the following order:

1. See that needle bar is set at correct height. See page 19.
2. Make sure that sewing hook is accurately timed. See page 20.
3. See that clearance between sewing hook point and needle is correct. See page 20.
4. Rotate bobbin case holder to its normal position and replace position finger.

5. Check position of bobbin case holder position finger Fig. 29. The clearance between position finger and bobbin case holder should be just sufficient to allow thickness of thread to pass through easily. Normal setting is for approximately .020 inch clearance, as shown in Fig. 29. The finger should also be level with the top of bobbin case holder.

When it is necessary to provide more clearance for needle, remove bobbin case holder from hook and remove a slight amount of metal from needle guard, by using a 1/8 inch strip of very fine emery cloth (about #320), holding one end of the emery cloth in a vise and rubbing the edge of the needle guard along the strip, as shown in Fig. 30. Extreme care

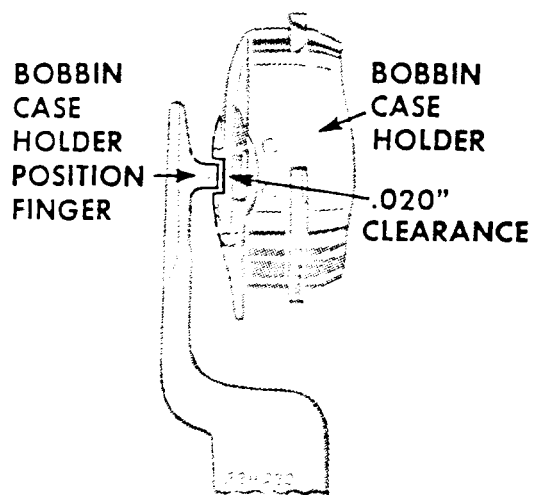

Fig. 29. Showing Thread Clearance Between Bobbin Case Holder Position Finger and Bobbin Case Holder

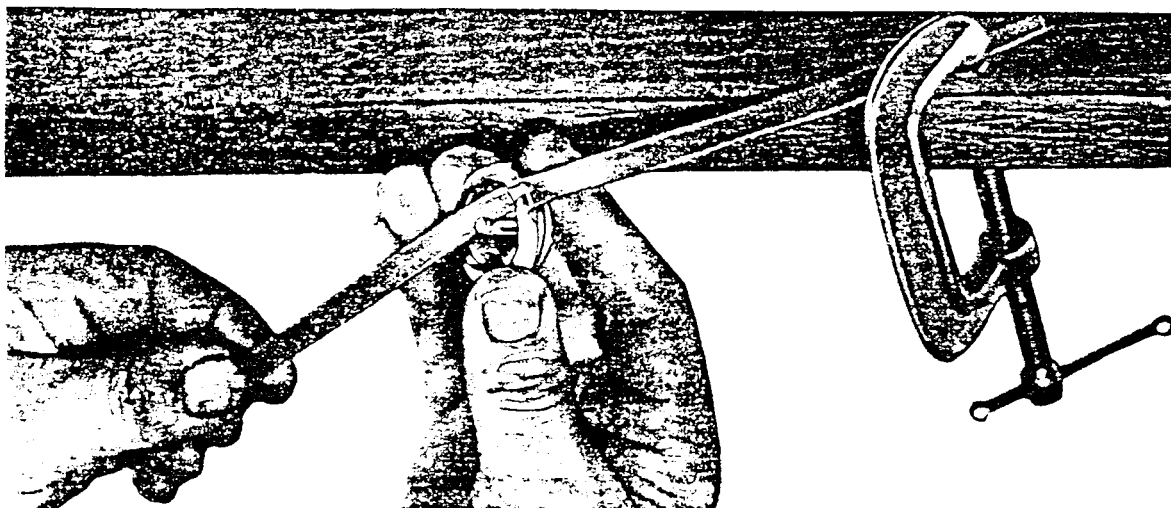

Fig. 30. Stringing Needle Guard of Bobbin Case Holder

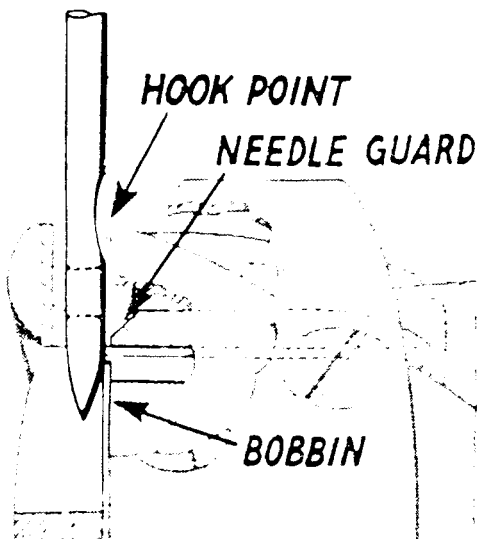

Fig. 31. Showing Needle Striking Bobbin Due to Removal of Too Much Metal from Needle Guard

must be taken not to remove too much metal as this will allow the hook point to rub the needle, causing wear or damage and thus necessitate replacing the hook and the bobbin case holder. Removing too much metal from guard can expose bobbin, permitting needle to strike it as shown in Fig. 31, and become damaged or broken and to also damage bobbin. Be sure to clean bobbin case holder thoroughly before replacing it.

TO REMOVE AND REPLACE THE SEWING HOOK

Remove the needle, slide plate and bobbin case. Take out the screw **Q2**, **Fig. 32** and remove the bobbin case holder position bracket **P2**. Loosen the two set screws at **M2** in the hub of the hook, then turn the machine pulley over from you until the feed bar **R2**, **Fig. 33** is raised to its highest point. Turn the sewing hook until the thread guard **T2** is at the bottom, as shown in **Fig. 33**, and turn the bobbin case holder **U2** until it is in the position shown in **Fig. 33**. The sewing hook can then be removed from the hook shaft.

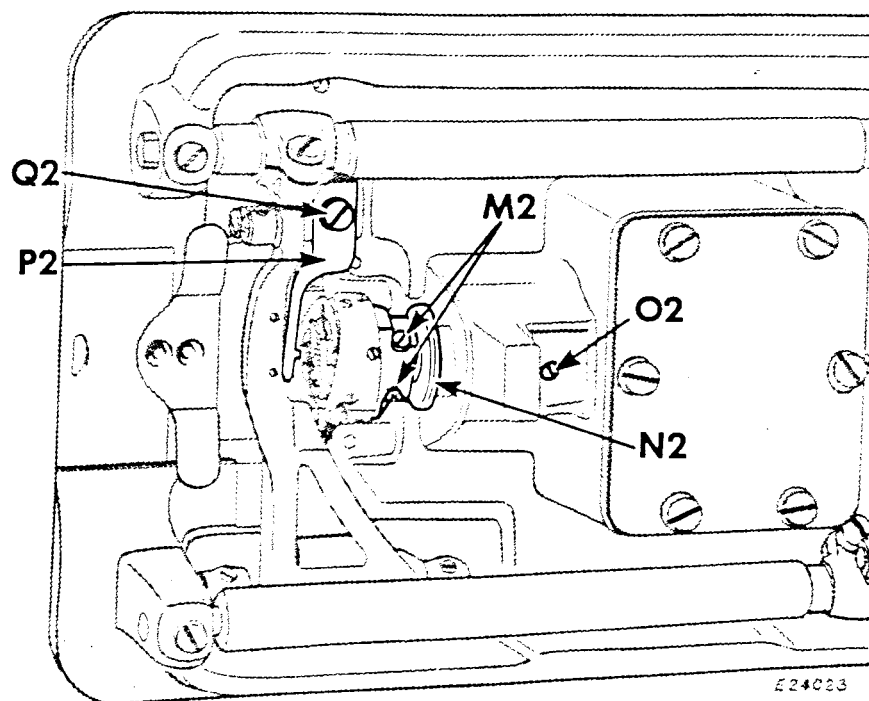

Fig. 32. Removing Hook

When placing a new sewing hook on the shaft, have the thread guard **T2** of the hook at the bottom and the bobbin case holder **U2** turned to the position shown in **Fig. 33**, so that the hook will clear the feed bar **R2**. Press the hook on the shaft up tightly against the shoulder.

When the hook is in position on the shaft, replace needle and retune as instructed on **page 20**. Turn the bobbin case holder **U2** until the notch **S2** is at the top, then replace the bobbin case holder position bracket, being careful to see that the position finger enters the notch at the top of the bobbin case holder, as shown in **Fig. 29**, then securely fasten the position bracket by means of the screw **Q2**, **Fig. 32**. Replace the bobbin case and slide plate.

TO REMOVE THE SEWING HOOK SHAFT

Remove the sewing hook as instructed on page 23. Loosen the pinch screw in the feed lifting rock shaft crank **C3**, Fig. 36 and drop the feed bar **R2**, Fig. 33 down out of the way. Loosen the bushing set screw **O2**, Fig. 32 and withdraw the bushing and hook shaft assembly as shown in Fig. 34. Take out the two screws **X2**, Fig. 34 and remove the end bearing **Y2**, Fig. 34, then withdraw the shaft and gear.

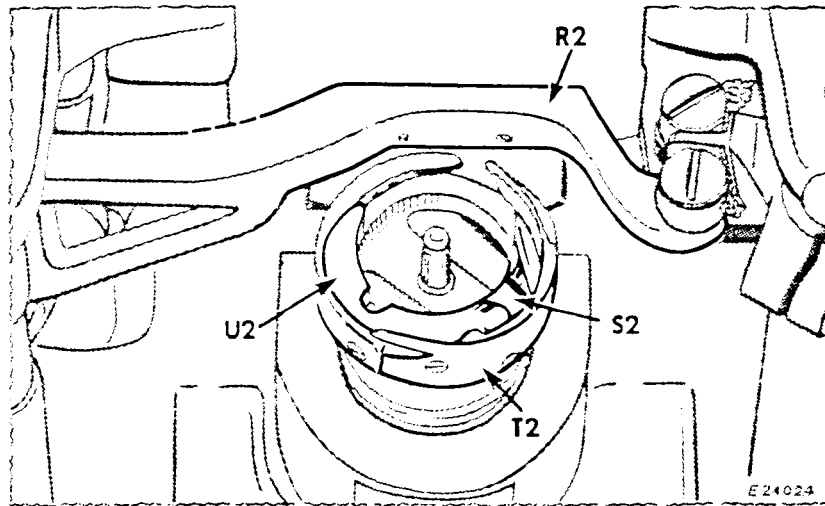

Fig. 33. Showing Correct Position of Thread Guard T2 and Bobbin Case Holder U2 for Removal of Sewing Hook

When assembling the hook shaft bushing, see that the thrust washer on the hook shaft has the raised surface toward the gear. The end bearing **Y2**, Fig. 34 can be moved endwise enough to control the end play of the hook shaft before tightening the two screws **X2**, Fig. 34. When replacing this unit in the machine, be sure that the set screw enters the spline in the bottom of the bushing. See page 27 when resetting the feed lifting rock shaft.

TO ADJUST ROTATING HOOK SHAFT BUSHING (Pressure Lubricating Type)

The hook shaft bushing contains a regulating screw **V2**, Fig. 34 for controlling the oil supplied to the sewing hook raceway. Turning in screw **V2** increases amount of oil supplied to the hook, as indicated by the arrow and word "more" on end of bushing; backing this screw out decreases amount supplied, as indicated by the arrow and word "less." Normal adjustment is accomplished by turning this screw in all the way, then backing it out again about 2-1/2 turns. Less than 2-1/2 turns may be required if continuous runs are being made or material with considerable sizing is being stitched.

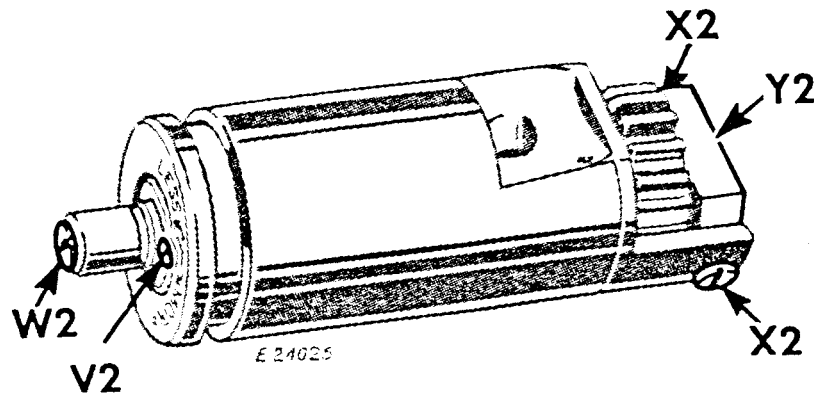

Fig. 34. Adjustment of Oil Flow Regulator in Hook Shaft Bushing

The oil wick complete No. 270176, **W2**, Fig. 34 carried by the hook shaft, at the sewing hook end, should be replaced occasionally as it may become clogged by lint and dirt from the oil.

Oil shield **U3**, Fig. 35 is provided to protect under side of throat plate and throat plate seat.

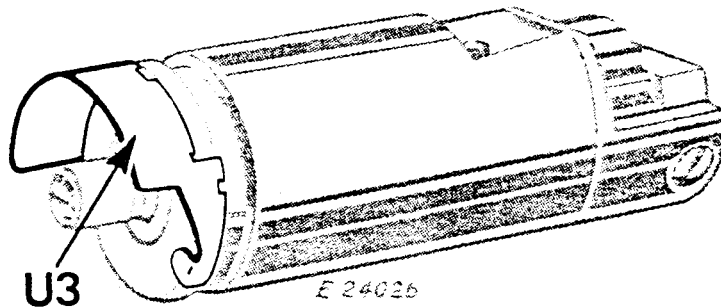

Fig. 35. Oil Shield Attached to Hook Shaft Bushing

If an excess of oil is being delivered to the hook and cannot be controlled by the metering screw **V2**, Fig. 34, check to be sure that the oil wick has not become detached from the filter screw **W2**, Fig. 34 and that the filter screw is securely tightened. Inspect all oil passages in the shaft and bushing to see that they have not become clogged with lint or dirt. If oil wick is too loose, too much oil will flow to the hook raceway.

To test for delivery of oil to the hook, run the machine at normal speed for one minute to remove any excess of oil and to establish a uniform rate of flow. Without stopping the machine, hold a small piece of white paper underneath the hook for 15 seconds without moving the paper during the interval. Remove the paper and inspect. If the paper does not show an oil streak about 1/32" wide, insufficient oil is being delivered to the hook. The most efficient method of testing oil delivery to hook is to remove hook and hold paper under end of hook shaft with machine running at full speed for 15 seconds; the oil streak should then be about 1/16" wide.

TO REMOVE AND REPLACE THE HOOK DRIVING SHAFT

Slip the belt off the lower pulley **F3**, Fig. 36, then loosen the two set screws **G3**, Fig. 36 and remove the pulley from the shaft. Loosen the four set screws **B3** and **E3**, Fig. 36 in the feed and feed lifting eccentrics, and the two set screws at **N3**, Fig. 36 in the internal gear. Do not loosen the screw in the collar **J3**, Fig. 36. Withdraw the shaft with ball bearing from the pulley end.

When replacing the shaft, make sure oil lead wire is in place in the shaft, and push shaft in, being sure the feed eccentrics are on the shaft in their proper order, until the snap ring on the ball bearing seats on the casting, then tighten gear screws **N3**. Before tightening the screws **B3**, the feed eccentric should be pushed to the left as far as it will go.

Tighten the screws **B3**, Fig. 36, having the first screw (as the shaft is turned away from you) enter the groove in the shaft. Then move the feed lifting eccentric to the left as far as it will go and tighten the screws **E3**, with the first or upper set screw in the groove in the shaft. Replace pulley **F3** and belt. Then retime the shaft as instructed on page 16.

If it is found necessary to replace the ball bearing on the hook driving shaft, or to reset or replace the hook driving shaft bushing, note that the ball bearing is correctly positioned when the pulley **F3**, Fig. 36 is flush with the ball bearing on one side and its hub is flush with the end of the shaft on the other. With the ball bearing in this position, place the shaft in the machine and assemble

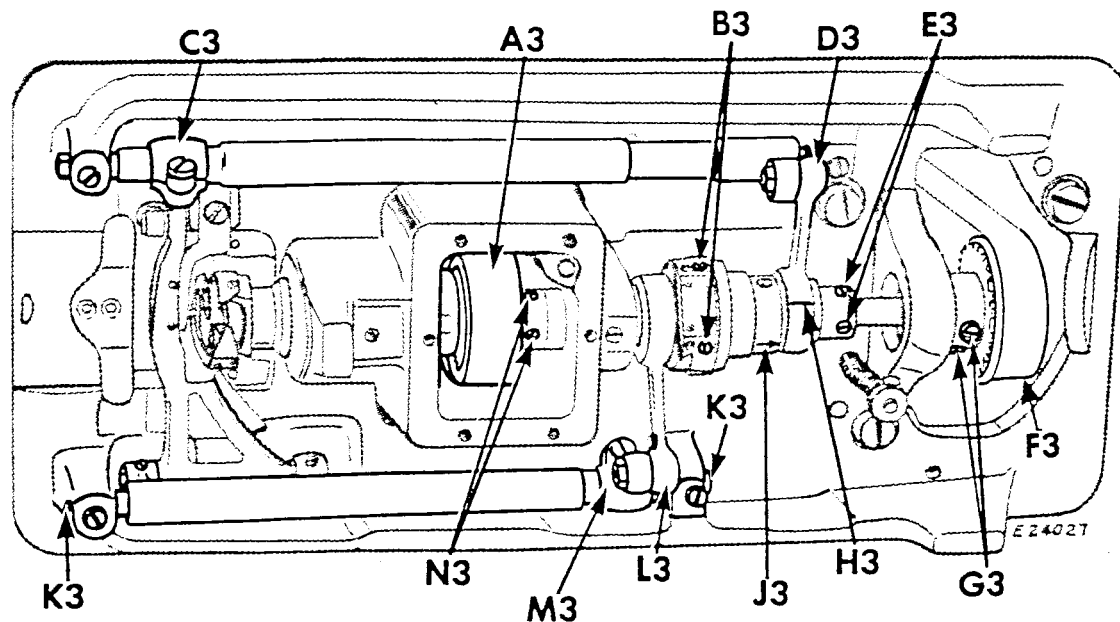

Fig. 36. Underside of Machine

the internal gear **A3**, Fig. 36 with its inner face flush with the end of the shaft. The hook driving shaft bushing will be correctly positioned when end play has been removed from the shaft by setting the bushing against the hub of the internal gear.

If the feed rock shafts have been disturbed, the small ends of the connections **D3** and **L3**, **Fig. 36** should be disconnected while setting the eccentrics, and enough side play left for the connections so that their free ends can be moved sidewise about 1/32 to 1/16 inch. See paragraph on feed mechanism before assembling the rock shaft connections.

The bearings for the feed rock shafts are fitted with Nylon inserts. These inserts may be removed when worn by inserting a screw in the threaded hole provided for this purpose in the insert.

FEED MECHANISM

If a faster or slower feed timing than the standard setting is desired see **page 26**, loosen the pulley screws **G3**, **Fig. 36** and turn the shaft as desired, then tighten the screws. The hook must then be retimed as instructed on **page 20**.

The feed dog is lined up with slots in the throat plate by moving the bearing centers at **K3**, **Fig. 36** to right or left. It may be centered lengthwise so it will not strike the ends of the slots when making the longest stitch, by loosening the clamp screw in the feed rock shaft crank **M3**, **Fig. 36**.

After removing the feed driving or feed lifting rock shafts, the cranks **M3** and **C3**, **Fig. 36** should be adjusted to right or left until they line up perfectly with the free ends of the connections when the latter are exactly midway between their two extreme side play positions. The cone bearings **D3** and **L3**, **Fig. 36** should then be adjusted by first turning the cone screws down tight and then backing them off about one-eighth of a turn, locking them in position with the lock nut. This gives a minute amount of play in the connection which is necessary for all clearance.

SETTING THE FEED DOG AT THE CORRECT HEIGHT

The feed dog may be raised or lowered by loosening the pinch screw in the feed lifting crank **C3**, **Fig. 36**. The feed dog is usually set so that it shows a full tooth above the throat plate when at its highest position. See that there is no lint packed between the feed dog and the throat plate.

ADJUSTING FEED ECCENTRIC

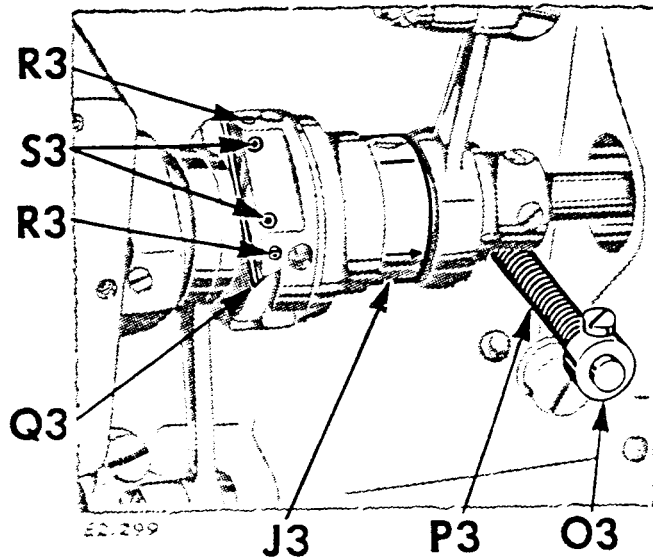

The feed eccentric is provided with a gib **Q3**, Fig. 37 which can be adjusted to take up any loose motion between the feed eccentric and the eccentric body. To adjust the gib, loosen the two locking screws **R3** nearest the gib, then turn in the two adjusting screws **S3** against the gib until all play is eliminated and the eccentric fits snugly in the slot in the eccentric body. Securely tighten the two locking screws **R3**. By tightening

Fig. 37. Feed Eccentric

the adjusting screws **S3** firmly, the eccentric will be locked so that the stitch length cannot be changed by unauthorized persons.

A spring held by the collar **J3** presses against the feed eccentric cam to prevent it from moving out of position while the machine is operating. The collar **J3** should ordinarily be set flush with the end of the hub of the eccentric body. The set screw in this collar must enter the timing groove in the eccentric body.

TO REMOVE AND REPLACE THE ARM SHAFT CONNECTION BELT

Remove the needle to avoid damaging it while the arm and hook shafts are out of time. Work the belt off the lower pulley **F3**, Fig. 36.

Loosen the two screws in the pulley groove and remove the machine pulley and the ball bearing which comes out with the pulley. Lift the belt up and draw it out around the arm shaft through the space normally occupied by the ball bearing.

Replace the belt through the ball bearing hole. After placing the belt over the upper pulley **T3, Fig. 39**, replace the machine pulley. To remove all end play from the shaft, lightly tighten the set screws in the machine pulley and, holding the needle bar crank in place, tap the machine pulley into position with the palm of the hand; then tighten screws firmly. Turn the arm shaft until the arrow

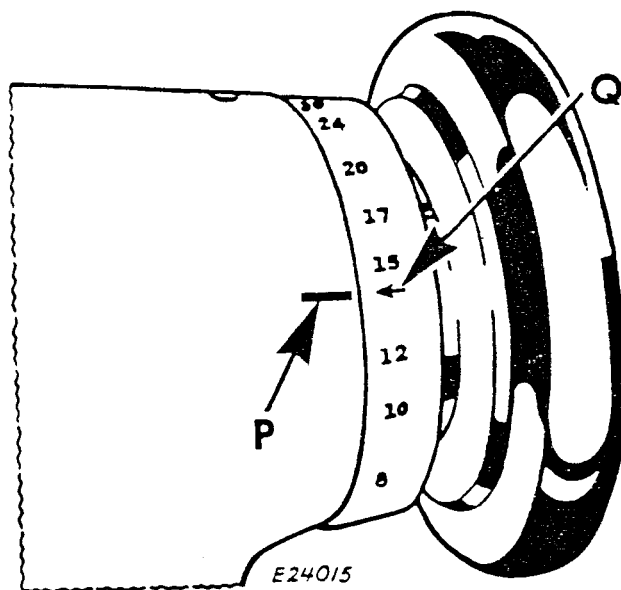

Fig. 38. Timing Arrow on Machine Pulley

Q, Fig. 38 on the machine pulley is in line with the mark **P, Fig. 38** on the arm casting, then turn the lower shaft pulley until the timing mark on the collar **J3, Fig. 36** is opposite the timing mark **H3, Fig. 36**, being careful to see that the two set screws **G3, Fig. 36** are accessible. With the two shafts, in this position, lead the belt onto the lower pulley at the point farthest from you and then, while turning the machine pulley over from you, slide the belt over the rest of the width of the lower pulley. Check the timing of the machine before starting to sew; see **page 16**, and if necessary, loosen the set screws in the lower pulley to bring the upper and lower shafts into exact time.

TO REMOVE THE ARM SHAFT

The arm shaft must be removed from the face plate end of the machine and under no circumstances should an attempt be made to separate the needle bar crank from the shaft, as they are manufactured as a unit for accuracy. Remove face plate **U**, **Fig. 19** and associated parts. Remove the needle set screw. Loosen the needle bar pinch screw **E2**, **Fig. 22**, remove the needle bar through the top of the arm, and remove the needle bar connecting stud. Remove the needle bar crank stud **Z**, **Fig. 21** by loosening the two set screws, reached through hole **R**, **Fig. 19** in the top of the arm. To remove the needle bar connecting link, drop it to its lowest position, draw

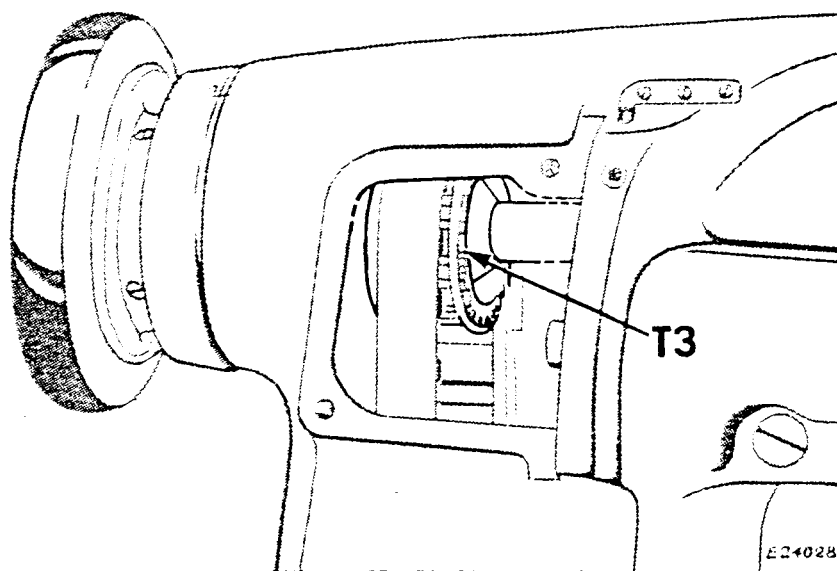

Fig. 39. Showing Upper Pulley

forward out of the guide block, turn at right angles, then draw upward and outward. (If for any reason the needle bar guide block is disturbed, it must be aligned properly when assembling the machine.) Remove the belt as instructed on the preceding page, loosen the spot screw and set screw in pulley **T3**, **Fig. 39** and withdraw the arm shaft and crank from the needle bar end. If it is found necessary to replace the ball bearing, it should be forced onto the shaft until it rests against the oiling felt flange, being careful not to crush the flange.

INSTRUCTIONS ON BALL BEARINGS AND NEEDLE BEARINGS

There are three ball bearings and three needle bearings in this machine that will give long, trouble-free life with reasonable care. Oiling instructions given on **pages 4 and 5** should be followed carefully. Care should be taken to see that no foreign matter gets into these bearings when handling them out of the machine.

The ball bearings on the forward end of the arm shaft, and the rear end of the hook driving shaft are forced on into their correct position at the factory and should not be removed except for replacement. When replacing them, make certain that the shielded side is always out and that they are a tight fit on their respective shafts.

The ball bearing on the machine pulley is also a forced fit. Tools for removing the machine pulley from the machine and for removing this bearing can be procured from the SINGER Shops if needed.

The three needle bearings should receive the same care as the ball bearings and should not be removed from their respective housings except for replacement. They should be replaced by pressing on the numbered end of the outside shell as any pressure on the unnumbered end of the shell will distort them and cramp the bearings. After this, care should be taken to see that the needle bearings roll freely in their respective housings.