

**SINGER**  
**591E/UTT**

**SINGER\***  
INDUSTRIAL PRODUCTS

**591E UTT**

## Operator's Guide

High Speed Single Needle Top Feed Machine  
WITH U.T.T., WIPER AND BACK TACK

\* A Trademark of THE SINGER COMPANY

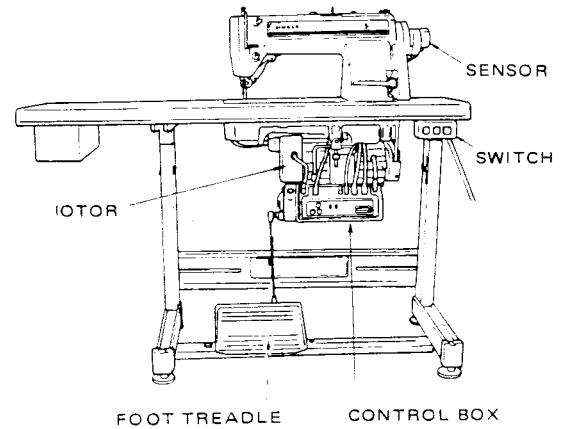

### CORDS AND CONNECTIONS

- Connect motor cord 1 to terminal 5 on motor.
- Connect sensor cord 2 to terminal 8 on control box.
- Connect trimmer solenoid and back tack solenoid cord 3 to terminal 7 on control box.
- Connect push button switch cord 4 (fastened to wiper solenoid cord) to terminal 6 on control box.

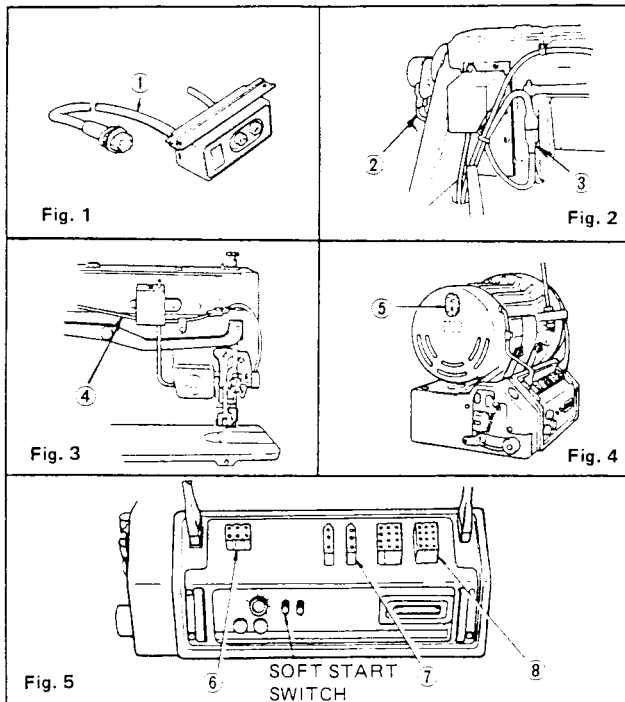

### SPEED

Relations between sewing speed, motor pulley (O.D.) and frequency:

O.D. of Motor Pulley (mm)	65	70	85	100	
Sewing Speed	50Hz	2,560	2,760	3,350	3,950
	60Hz	3,070	3,310	4,020	

### HINTS FOR PERFECT OPERATION

- When turning the machine pulley, always turn it over toward the front of the machine. Be careful not to let it rotate in reverse.
- Be sure to turn off the power switch before tipping the machine back for cleaning and oiling.
- Turn off the power switch if the needle does not rise and stop even when the trimmer solenoid is activated by heeling the foot treadle.
- The needle will not descend and the trimmer will not operate when the foot treadle is heeled immediately after turning on the power switch or immediately after completion of a thread trimming cycle. The needle will stop in down position and the trimmer will operate once the foot treadle is depressed for normal sewing.

**NOTE:** May we recommend that this manual be used together with the operator's guide From U3657 furnished with the regular machines.

## OPERATING THE FOOT TREADLE

The foot treadle is operated in four steps as explained below and the sewing speed can easily be controlled by the amount of pressure applied on the treadle. (Fig. 6)

- ① For low speed sewing, depress the foot treadle lightly.
- ② For high speed sewing, depress the foot treadle all the way.
- ③ The machine will stop with needle down when foot treadle is returned to its neutral position.
- ④ The machine will stop with needle up after trimming the thread when foot treadle is heeled.

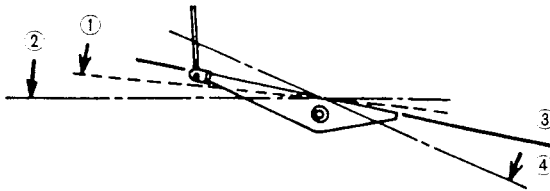

Fig. 6

- Quick heeling of the foot treadle from either high or low speed sewing will not affect the thread trimming performance.
- Once the trimmer starts its trimming cycle, it will complete the cycle even if the foot treadle is released to return to its neutral position. Consequently, you need not continue to heel the foot treadle until the thread is trimmed.
- The foot treadle, even when depressed, will not start the machine for normal sewing immediately after it has been heeled for thread trimming. This is because the safety device provided in the control box has been activated to hold the machine from being started until the thread trimming cycle has been completed.

## USING THE SOFT START SWITCH

This soft start feature makes it possible to trim the needle thread end as short as possible and also prevent the thread end from being pulled out of the needle eye at start of sewing.

When the soft start is required at the start of sewing, turn the soft start switch "ON" shown in Fig. 5.

## THREADING THE MACHINE

Lead thread from the thread stand through threading points in the order shown in Fig. 7.

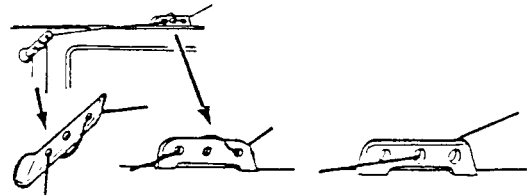

Fig. 7

Fig. 8

- When using cotton threads or threads that do not slip easily, pass the thread through eye of thread guide as shown in Fig. 8.

## ADJUSTING THREAD TENSIONS

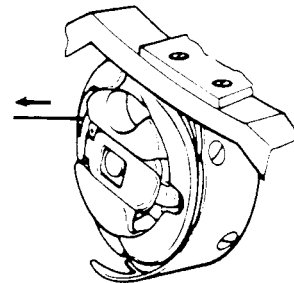

Fig. 9

### NOTE:

1. In addition to the regular tension spring, a special spring to prevent spillage of the bobbin is provided on the bobbin case used on this machine, therefore the tensions of the two springs should be adjusted to give 20 to 25 gram thread tension when thread is pulled in the direction shown in Fig. 9.
2. The needle thread may not be cut if looping or skip stitching occur. In such case, the needle thread tension requires adjustment.

## WINDING THE BOBBIN

Bobbin winding is performed in the same way as for regular machines.

- Winding should be held to approximately 80% of winding capacity.
- Tetron and Nylon threads should be wound loosely.
- The aluminum bobbin should be used.

## ADJUSTING THE LENGTH OF NEEDLE THREAD END

The length of needle thread end should be adjusted so that sewing can be started without the thread end being pulled out of needle eye or without excessive thread end showing on the underside of the fabric. This adjustment can be done by adjusting the slack thread regulator action plate.

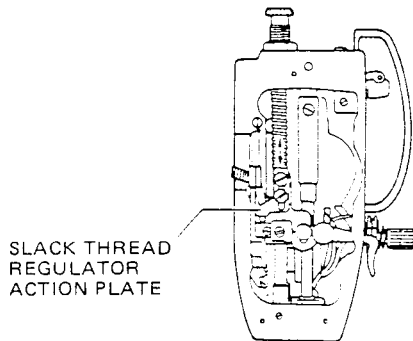

Fig. 10

- To adjust length of thread end with slack thread regulator action plate. (Fig. 10)
  - a. Move slack thread regulator action plate up to shorten the thread end.
  - b. Move slack thread regulator action plate down to lengthen the thread end.

## ADJUSTING THE TRIMMER

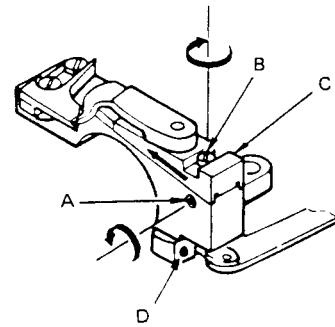

Fig. 11

If the cutting quality of the knife appears poor, remove the throat plate and adjust the pressure on the cutting knife as instructed below.

- a. Loosen screws A and D shown in Fig. 11.
- b. Turn eccentric stud B clockwise to move the wedge shaped slide block C in the direction shown in Fig. 11.

The pressure on the cutting knife should be only heavy enough to ensure clean cut. Excessive pressure may result in malfunction of the trimmer.

## SHARPENING THE STATIONARY KNIFE

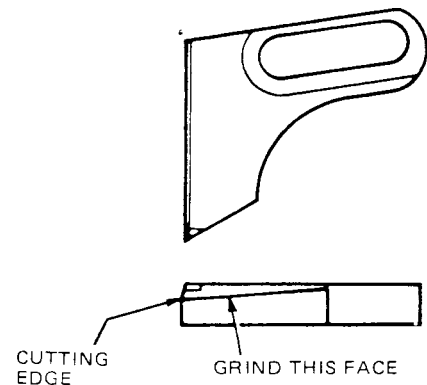

Fig. 12

If cutting quality can not be improved by making the above adjustments, the stationary knife should be removed and resharpened. (Fig. 12)

When replacing the stationary knife, set the knife so that its cutting edge is parallel to the feed dog with 0.3mm (.012 in.) clearance.

The movable knife need not be resharpened.

## ADJUSTING THE SENSOR

If the tension releasing mechanism is not released when the needle stops in its upper stop position, adjust the position of the sensor as instructed below. (Fig. 13)

- Loosen the two set screws and while holding the sensor with one hand, turn machine pulley over toward front of machine until the tension releasing mechanism is released.
- Hold the sensor in this position and tighten the two set screws.

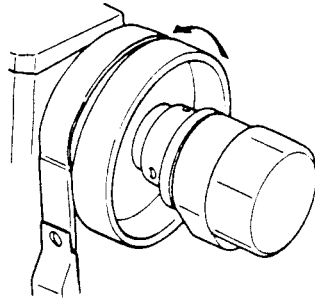

Fig. 13

## USING THE PUSH BUTTON BACK TACK

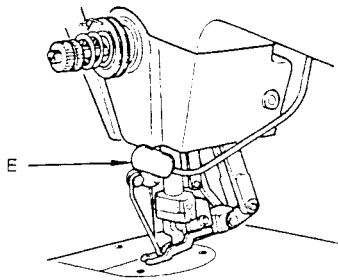

Fig. 14

- When push button **E**, Fig. 14, is depressed, the machine will immediately change from forward to reverse feed for back tacking and return to forward feed when released.
- The machine will continue to sew in reverse while the push button is depressed, however, when the machine is stopped, the protective circuit automatically cuts off the current supply to the solenoid after 12 seconds even when the push button is continuously depressed.

## USING THE WIPER

- The wiper is very convenient for sewing operation such as sewing the needle thread end into the stitches on the underside of the fabric.
- Turn the wiper switch **F** off when sewing operation does not require the wiper. (Fig. 15)

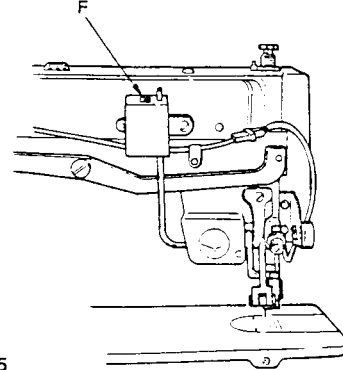

Fig. 15

## CARING FOR YOUR MACHINE

How often you will need to clean and lubricate the machine will depend on how often you will use it. When in regular use the machine should be cleaned periodically to remove lint and fluff which may have accumulated around the working parts.

- Remove throat plate and clean feed dog, sewing hook and trimmer area.
- Clean out any lint or other waste in the oil reservoir and on the filter screen of the oil pump.

## SPECIFICATIONS

Machine	591E200G/210G
Type of Feed	Drop Feed and Variable Top Feed
For Sewing	Light to Medium
Needle Bar Stroke	30.5mm
Max. Speed	4000 S.P.M.
Max. Stitch Length	5mm
Presser Bar Lift (By Hand)	6mm
Presser Bar Lift (By Knee)	10mm
Trimming Speed	200 S.P.M.
Sewing Hook	#544784 for 591D UTT Machines
Bobbin Case	#540735 for 591 UTT Machines
Bobbin	#272152 (Aluminum) must be used
Thread Trimmer	Scissor Type, Capable of Cutting up to #8 Cotton
Trimmer Driving System	Solenoid and Cam Controlled
Back Tack Speed	From 1300 to 1700 S.P.M.