

SINGER
2191D, 200A, 300A

INSTRUCTION MANUAL
ILLUSTRATED PARTS LIST

FOR

SINGER

MACHINES

2191D 200A
300A

THE SINGER COMPANY

Contents

Instructions for Operation	1
Illustrated Parts List	10
(for Light to Medium Weight Material)	10
1. Arm Bed Components	10
2. Main Shaft and Thread Take-up Components	12
3. Needle Bar and Thread Tension Components	14
4. Presser Bar Components	16
5. Hook Driving Shaft Components	18
6. Feed Mechanism Components	20
7. Feed Regulating Components	22
8. Lubrication Components	24
9. Oil Reservoir and Knee Lifter Components	26
10. Thread Stand Unit Components	28
11. Machine Head Accessories	30
(for Medium to Heavy Weight Material)	32

Pre-start checks:

1. Do not run the machine unless there is oil in the oil reservoir.
2. When running the machine the direction of rotation of the handwheel must be counterclockwise when viewed from right hand side. Do not run the machine with handwheel rotating in the clockwise direction.
3. Sewing speed should be reduced by 500 s.p.m. from rated maximum speed during the first month of operation.

Notes on use:

1. Keep hands away from the needle area of the machine while the machine is running.
2. Do not put fingers near the take-up area while the machine is running.
3. Insure that the machine has come to a stop before turning the handwheel by hand.
4. Before tipping the machine back, first switch off the power to the motor. After switching off the power you must wait for the motor to stop, as it will continue to run, due to inertia, for a short while. Only when the motor is completely stopped is it safe to tip the machine back.
5. While the machine is running keep hands, hair or anything else that could get caught away from the handwheel, V-belt, bobbin winder, motor, needle and take-up areas.
6. Do not start the machine during mounting or replacing the belt guard and finger guard etc.

1. Installation of the machine (Fig.1, Fig.2.)

To install the oil reservoir:

Place the rubber cushions ① and the felt cushions ③ at the four (4) recessed corners of the table, fixing them in place with wood screws ②. Now place the oil reservoir into the table. (Fig. 1)

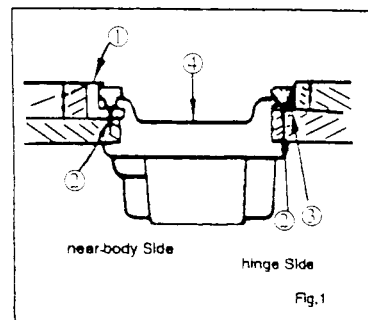

Place the two rubber inserts ②, for the machine hinges, into the recesses in the table top. (Fig. 2)

Assemble the machine hinges ① into the back of the machine bed. (Fig. 2)

Now place the machine into the cut out in the table top so that it rests on the cushions in the four corners and the machine hinges sit into the rubber inserts.

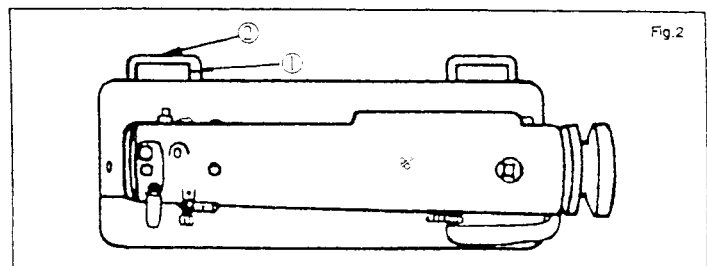

2. Oiling (Fig. 3 and 4.)

Before starting the machine:

1. Fill the oil reservoir with Singer oil type C until it is level with the 'HIGH' mark indicated in the oil reservoir. (Fig. 3)
2. If the oil level is below the 'LOW' mark, more oil should be added.
3. Start the machine slowly, gradually increasing the speed to the maximum set speed. During this running, check to see that oil is spraying onto the oil sight window. If no oil is seen in the oil sight window, do not continue to run the machine. This problem must be investigated before running the machine further.

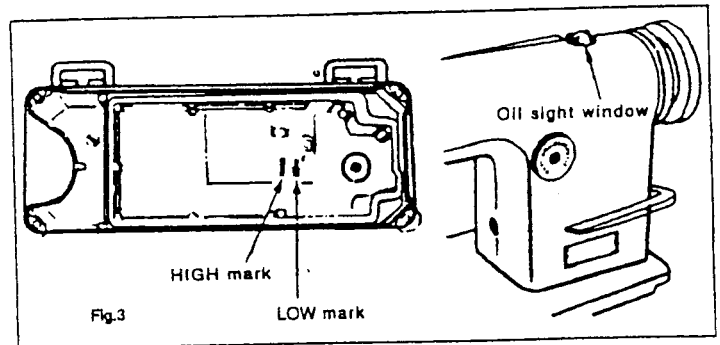

To adjust the amount of oil to the head of the machine :

Refer to the left hand portion of Fig.4. Turning the adjusting pin ① towards the take-up crank will decrease the amount of oil to the head end. Turning it away from the take-up will increase the amount of oil.

To adjust the oil flow to the rotating hook :

Refer to right portion of Fig. 4. Turning the adjusting screw ③ in a clockwise direction ('+') will increase the oil flow to the rotating hook and turning in a counter clockwise direction ('-') will decrease the flow.

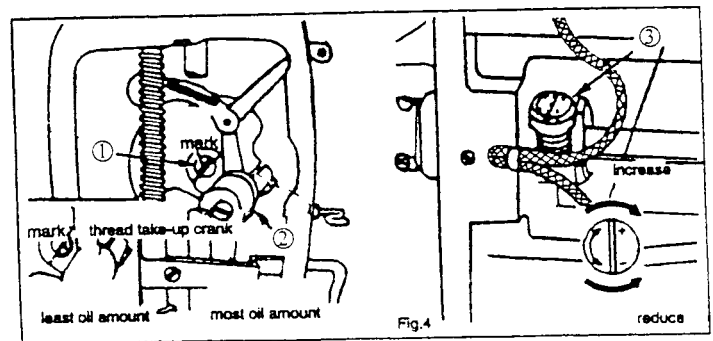

Note : With a new machine or an older one that has not been used for some time, the machine should be run around 3,500 s.p.m. for approximately ten minutes.

3. To set the needle (Fig. 5)

1. Switch off power to the motor. Make sure the motor has completely stopped before proceeding.
2. Turn handwheel until the needle bar has reached it's highest position.
3. clamping screw ②. Align the needle ① so that the concave portion is on the right. (long groove in needle to the left)

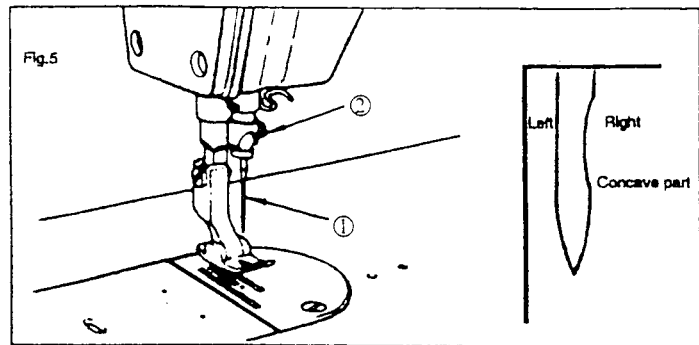

4. Insert the needle into the hole in the needle bar as far as it will go. Now tighten the needle clamping screw ②.

4. To fit and remove the bobbin case (Fig. 6)

1. Release the bobbin case latch lever and bobbin case and bobbin can be removed from rotating hook. With the bobbin case latch lever open it will hold the bobbin in the bobbin case.
2. To fit the bobbin case and bobbin into the rotating hook, place the assembly onto the bobbin case holder spindle, and push it in as far as it will go. Insure that the bobbin case latch lever is closed.

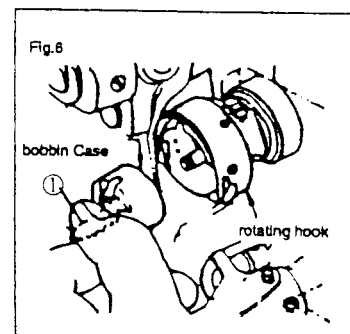

5. To wind the bobbin thread (Fig. 7)

1. the two eyelets and around the thread tension at the back of the bobbin winder. Pull the thread forward in the direction of the arrow shown in Fig. 7.
2. Wind the thread around the bobbin, a few turns.
3. Press down on the bobbin winder stop latch until it engages with the
4. To set the amount of thread wound onto the bobbin, turn the adjusting screw in a clockwise direction for more thread and a counter clockwise direction for less thread.

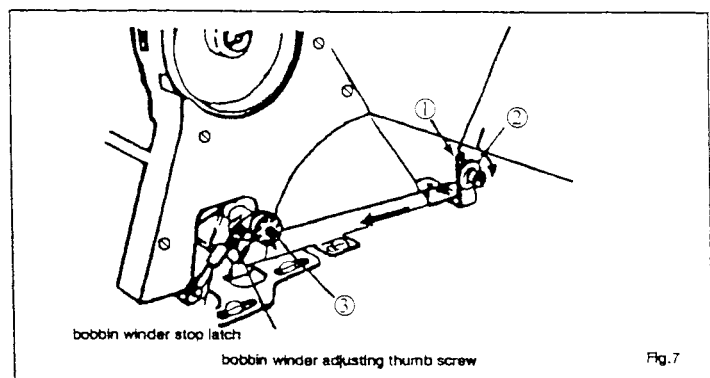

5. If the bobbin thread is not wound evenly, adjust the position of the bobbin winder tension bracket, until even winding is obtained.
6. The bobbin winder will stop automatically and the bobbin winder stop latch will return to the disengaged position.

6. To thread the bobbin case (Fig. 8)

1. Hold the wound bobbin so the thread unwinds in the direction shown in Fig. 8. Place bobbin into bobbin case.
2. Pull thread through the notch in side of bobbin case and draw it under the tension spring, pulling it out at the end of the tension spring. When the thread is pulled, the bobbin should move in the direction of arrow shown in Fig. 8.

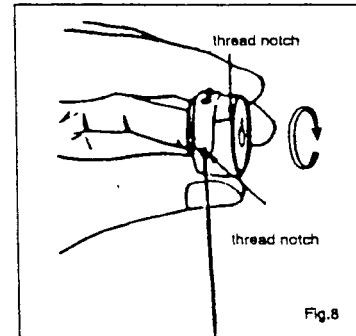

7. To thread the needle thread (Fig. 9)

Turn handwheel until needle is at its highest position, then pass the needle thread from the left spool on the unwinder through the threading point in the order shown in Fig. 9.

Thread the needle from left to right. Draw about 50 m.m. of thread through eye of needle with which to commence sewing.

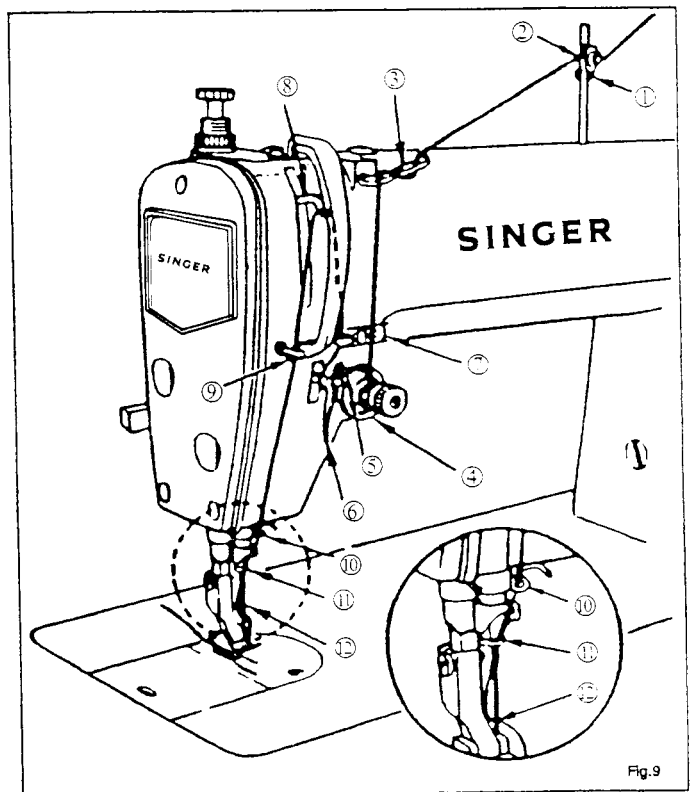

8. To adjust stitch length (Fig. 10)

1. Press down on the reverse feed lever, now turn feed regulating dial ① to the desired number, stitch length in m.m., release the reverse feeding lever. The dial is now locked in this position by the pin inside the arm.
2. To set feed mechanism in the reverse motion, press down on the reverse feed lever. When released the reverse feed lever will automatically return to the forward feeding position.

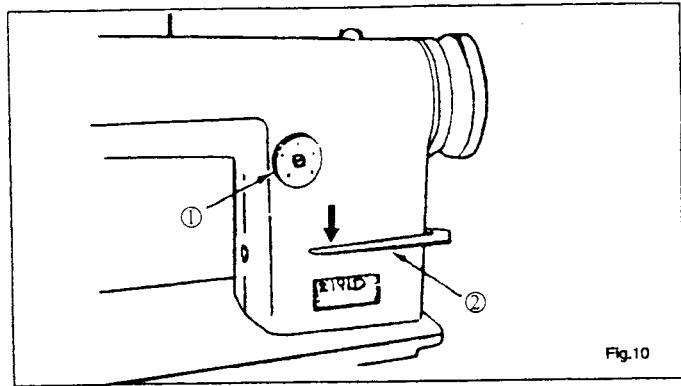

Fig.10

9. Needle and Bobbin Tensions (Fig. 11)

To adjust needle thread tension :

Depending on the sewing conditions, the needle thread tension can be adjusted by increasing or decreasing the effect of tension spring ①. To increase, turn the thumb nut clockwise and to decrease, counter clockwise.

To adjust the bobbin thread tension :

Turn tension screw ② clockwise to increase tension and counter clockwise to decrease.

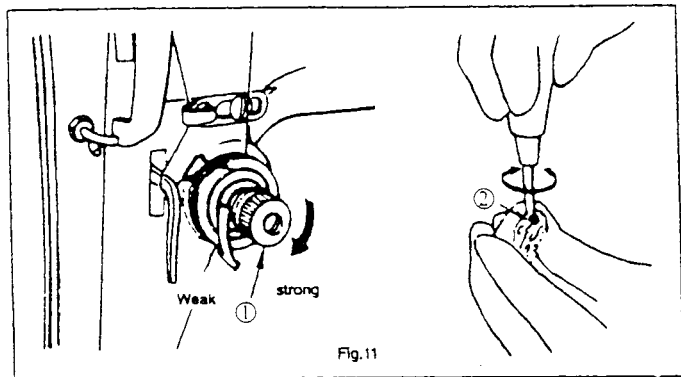

Fig.11

10. Thread take-up spring (Fig.12)

To change the stroke of the thread take-up spring ①, loosen the set screw ② in the arm casting and turn complete tension assembly, by using a screw driver in slot ③, clockwise to increase the stroke and counter clockwise to decrease.

To change the tension of the thread take-up spring :

1. Loosen set screw ② such that the complete tension assembly can be removed from the machine.
2. Slightly loosen set screw ④ and turn tension stud ③ inside the assembly, clockwise to increase the tension and counter clockwise to decrease.
3. Retighten set screw ④ and refit complete tension assembly into the machine arm., securing with set screw ②.

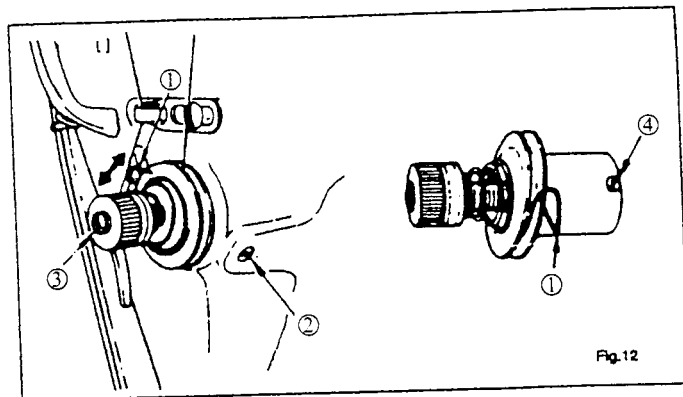

11. Presser Bar Lifter (Fig. 13)

To keep the presser foot in the raised position turn the hand lifter lever ① either left or right. Using the hand lifter lever, the lift of the presser foot will be approximately 5.5 m.m.. When the knee lifter is used the lift of the presser foot will be approximately 12 m.m..

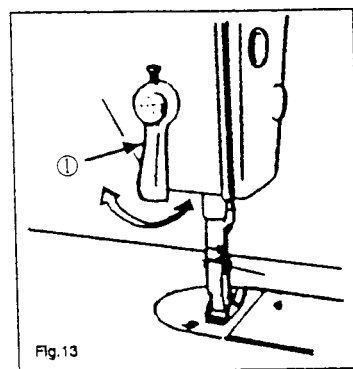

12. To adjust pressure on the presser foot (Fig. 14)

Turn the pressure regulating thumb screw clockwise to increase the pressure and counter clockwise to decrease.

For sewing on a general fabric, the height of the thumb screw will be approximately 27~30 m.m., giving a pressure of approximately 5 Kg.

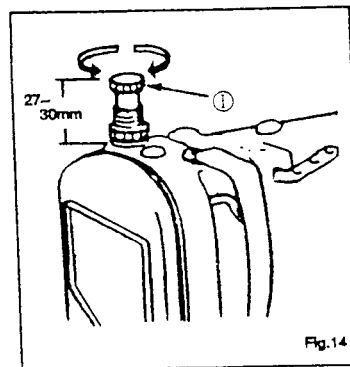

13. Height of feed dog (Fig. 15)

The top of the feed dog should be 0.7~0.8 m.m. above the top of the throat plate. When sewing light weight material it is extremely important that the feed dog be set to the correct height otherwise puckering of the fabric will result.

To adjust the height of the feed dog :

1. Loosen clamping screw ② of feed lifting rock shaft crank ①.
2. Move the feed bar up or down to obtain the correct feed dog height.
3. Retighten the feed rock shaft crank clamp screw.

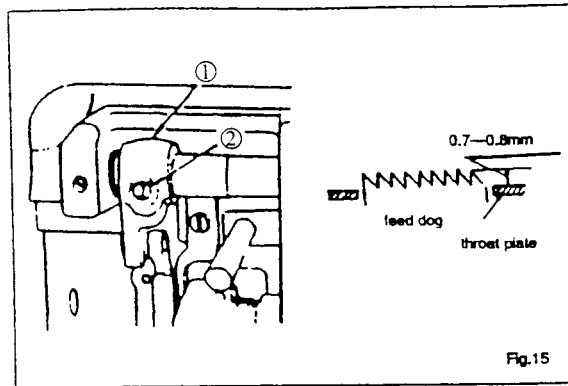

14. Needle and rotating hook relationship (Fig. 16)

Relationship between needle and rotating hook should be set as follows :

1. Turn handwheel until needle bar reaches it's lowest position.
2. In this position the line 'A' on the needle bar should align with the lower edge of the lower needle bush ③. If these two marks do not line up then the needle bar height has to be altered. Loosen needle bar connecting stud screw ① and reposition the height of the needle bar. With the two marks aligned, retighten the needle bar connecting stud screw ①.

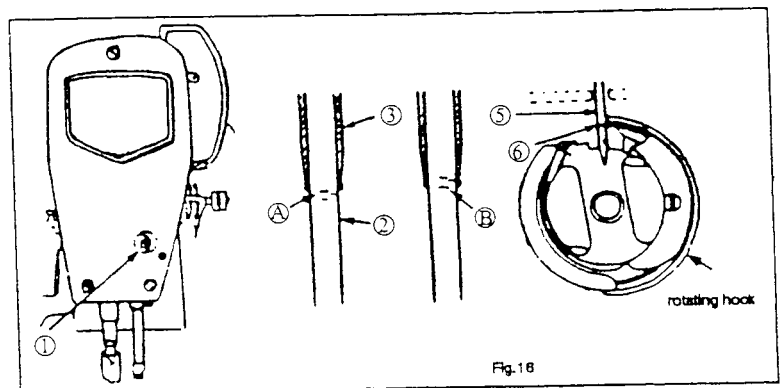

3. Loosen the two set screws on the hub of the rotating hook, and turn handwheel until the lower line 'B' on the needle bar ② aligns with the lower edge of lower needle bar bush ③.
4. Now turn the rotating hook on the hook shaft until the hook point ⑥ is in line with the center line of the needle ⑤. The clearance between the rotating hook and the needle in this position should be 0.02~0.05 m.m.. In this position retighten the two set screws on the hub of the rotating hook.

15. To adjust presser bar height (Fig. 17)

To adjust the height of the presser bar, loosen presser bar guide bracket clamp screw ① and raise or lower the presser bar. Retighten the clamping screw.

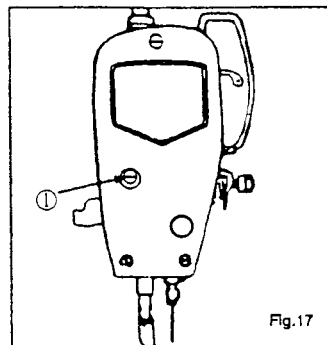

16. To adjust thread supply from take-up lever (Fig. 18)

When sewing heavy material, move the thread guide to the left to increase the amount of thread.

When sewing light weight material, move the thread guide to the right to decrease the amount of thread.

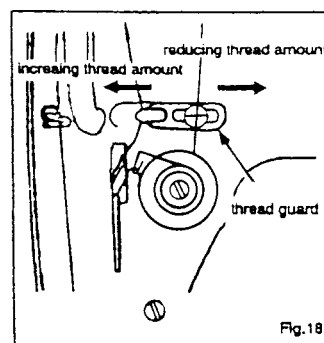

17. Specifications :

	2191D200A	2191D300A
Sewing Material	Light to Medium	Medium to Heavy
Sewing Speed	4,500 s.p.m.	4,000 s.p.m.
Max. Stitch Leng	4.0 m.m.	4.5 m.m.
Presser Foot Lift	12 m.m. (by knee)	12 m.m. (by knee)
Needle	Cat. 2270 (DBx1) #14	Cat. 2270 (DBx1) #18
Lubricating Oil	Type 'C'	Type 'C'

18. Mounting the Belt Guard and Bobbin Winder (Fig. 19)

1. Drill pilot holes for wood screws in table top at locations A, B, C, and D.
2. Assemble nut ① onto support ② and then screw support ② into the tapped hole in Arm.
3. Install front section of belt guard ③, positioning handwheel in the center of the cut.
4. Install the back portion of the belt guard at 'C' and 'D'.
5. Use screws ⑤ and ⑦ and washer ⑥ to fix the front portion of the belt guard to the support ②. Adjust the seating of the belt guard with nut ①.
6. Move the back portion of the belt guard ④ backwards until the rubber portion touches the front portion of the belt guard cover ③, continue moving it backwards another 0.5-1.00 m.m. and secure in this position with wood screws and washers.
7. Bobbin Winder ⑩ should be located at 'A' and 'B' and secured with wood screws.

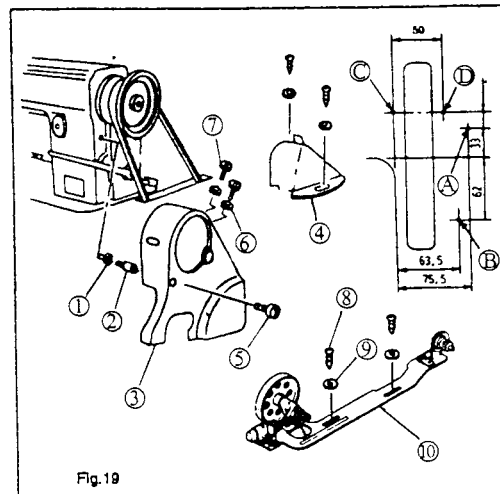

Model 2191D200A (for Light to Medium Weight Material)

1. Arm Bed Components

<u>Ref. No.</u>	<u>Part No.</u>	<u>Description</u>	<u>QTY.</u>
1	606006	Arm/Bed comp.	1
2	606007	Face Plate assm.	1
3	606238	Screw	3
4	606009	Rubber Plug	2
5	606010	Gasket	1
6	606011	Screw	8
7	606012	Side Plate	1
8	606013	Gasket	1
9	606014	Screw Hole Plug	1
10	606015	Rubber Plug	4
11	606015	Rubber Plug	1
12	606016	Rubber Plug	1
13	606017	Rubber Plug	1
14	606018	Hook Shaft Rubber Plug	1
15	606019	Rubber Plug	1
16	606020	Bed Support	1
17	606021	Nut	2
18	606022	Bed Stud (short)	1
19	606023	Bed Stud (long)	1
20	606024	Model Plate	1
21	606025	Model Plate Rivet	4

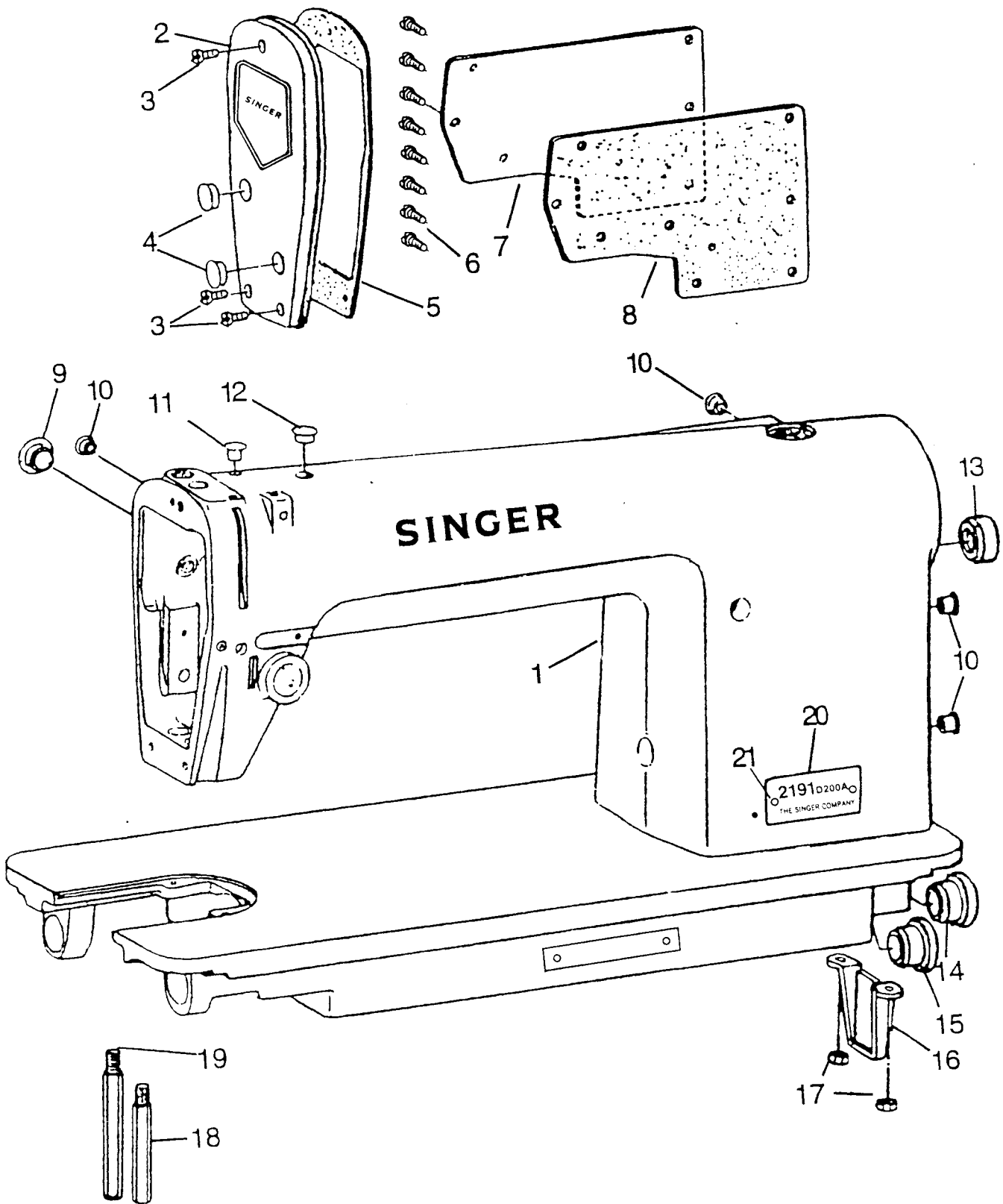

2. Main Shaft and Thread Take-up Components

<u>Ref. No.</u>	<u>Part No.</u>	<u>Description</u>	<u>QTY.</u>
1	606026	Thread Take-up Lever assm.	1
2	606027	Thread Take-up Lever Link	1
3	606028	Oil Wick	1
4	606029	Thread Take-up Crank Shaft Stud assm.	1
5	606030	Oil Wick	1
6	606031	Screw	1
7	606032	Needle Bar Crank	1
8	606033	Thread Take-up Crank Screw (left hand)	1
9	606034	Needle Bearing	1
10	606035	Main Shaft	1
11	606036	Oil Regulating Felt	1
12	606037	Crank Oil Adjusting Pin	1
13	606038	O-Ring	1
14	606039	Rubber Bushing	1
15	606040	Counterweight assm.	1
16	606041	Screw	1
17	606042	Screw	1
18	606043	Screw	1
19	606044	O-Ring	1
20	606211	Screw	1
21	606046	Counterweight Wear Plate	1
22	606047	Main Shaft Bushing (front)	1
23	606031	Screw	1
24	606049	Main Shaft Bushing (intermediate)	1
25	606220	Screw	1
26	606051	Thrust Collar	1
27	606211	Screw	2
28	606053	Main Shaft Bushing (rear)	1
29	606031	Screw	1
30	606055	Rubber Ring	1
31	606056	Handwheel	1
32	606057	Screw	2
33	606058	End Screw	1
34	606059	Thread Take-up Lever Cover	1
35	606060	Screw	1

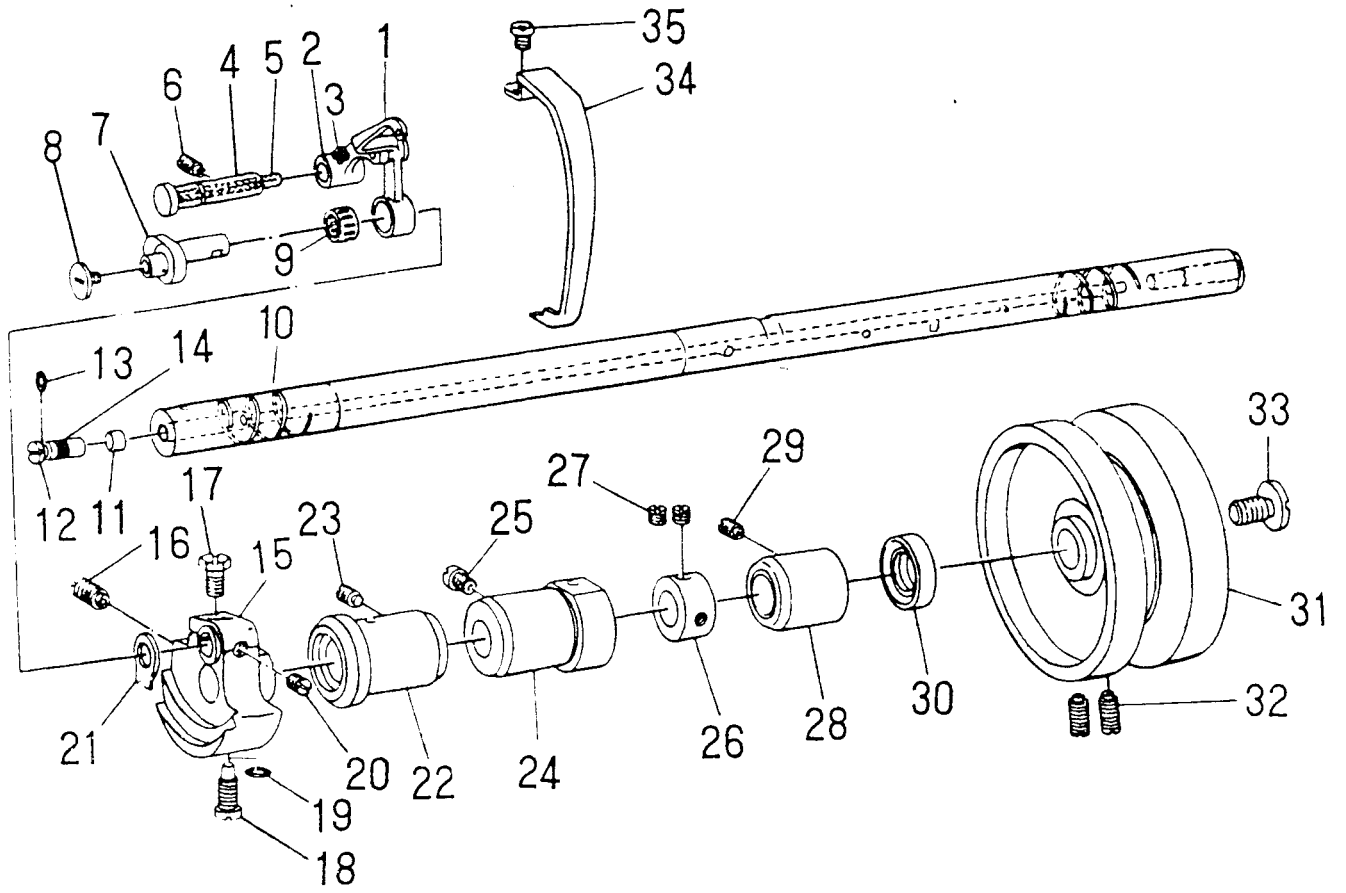

3. Needle Bar and Thread Tension Components

<u>Ref. No.</u>	<u>Part No.</u>	<u>Description</u>	<u>QTY.</u>
1	606061	Rubber Plug	1
2	606062	Needle Bar Bushing (upper)	1
3	606063	Screw	1
4	606064	Needle Bar Bushing (lower)	1
5	606065	Needle Bar	1
6	606066	Needle Bar Connection assm.	1
7	606067	Screw	1
8	606068	Needle Bar Crank Rod	1
9	606069	Needle Bar Guide Block	1
10	606034	Needle Bearing	1
11	606071	Thread Guide	1
12	606072	Thread Guide	1
13	606073	Screw	1
14	N2270#14	Needle	1
15	606074	Tension Release Aux. Pin	1
16	606075	Tension Release Pin	1
17	606076	Thread Tension Post Socket	1
18	606077	Screw	1
19	606243	Screw	1
20	606079	Take-up Spring	1
21	606080	Thread Tension Post	1
22	606081	Tension Disc	2
23	606082	Tension Release Disc	1
24	606083	Tension Spring	1
25	606084	Tension Disc Stopper	1
26	606085	Thread Tension Nut	1
27	606086	Needle Thread Guide Pin assm.	1
28	606087	Needle Thread Guide Pin	1
29	606088	Tension Disc	2
30	606089	Spring	1
31	606090	Stud	1
32	606067	Screw	2
33	606092	Presser Bar Clamp Thread Guide	1
34	606093	Nut	1
35	606094	Thread Guide	1
36	606095	Screw	1
37	606096	Thread Guide	1
38	606097	Screw	1
39	606098	Three Hole Thread Eyelet	1

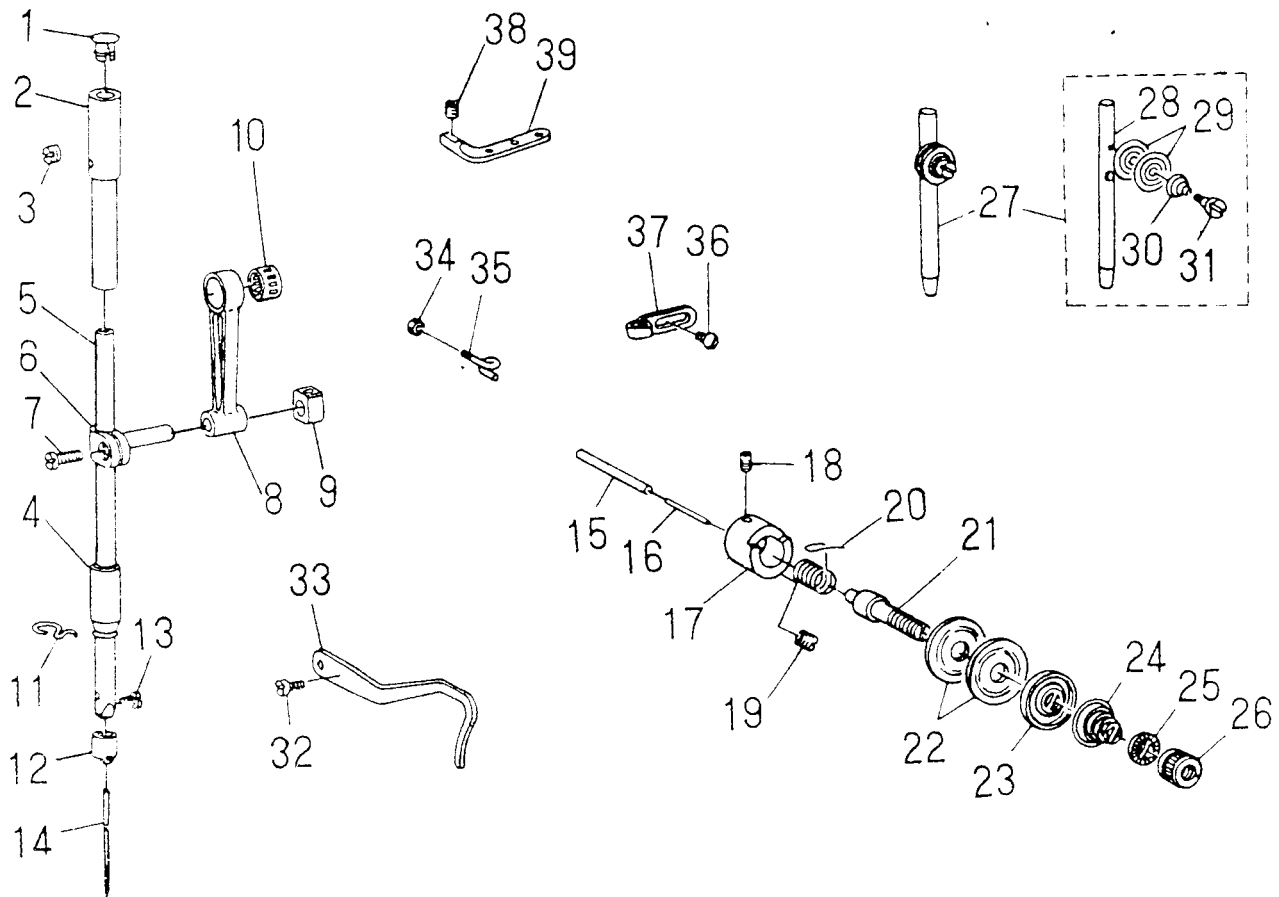

4. Presser Bar Components

<u>Ref. No.</u>	<u>Part No.</u>	<u>Description</u>	<u>QTY.</u>
1	606099	Pressure Spring Regulator Nut	1
2	606100	Pressure Spring Regulator	1
3	606101	Presser Guide Bar	1
4	606102	Presser Bar Spring	1
5	606103	Presser Bar	1
6	606104	Presser Bar Guide Bracket assm.	1
7	606105	Clamp Screw	1
8	606106	Presser Bar Bushing (lower)	1
9	606107	Screw	1
10	606002	Presser Foot	1
11	606108	Hand Lifter Lever	1
12	606109	Screw	1
13	606110	Washer	1
14	606111	Hand Lifter Cam assm.	1
15	606112	O-Ring	1
16	606113	Lifting Lever	1
17	606114	Hinge Screw	1
18	606115	Hinge Screw	1
19	606116	Hinge Screw	2
20	606117	Snap Ring	2
21	606118	Lifting Lever Link	1
22	606119	Shaft	1
23	606120	Gasket	1
24	606121	Snap Ring	1
25	606122	Snap Ring	1
26	606123	Lifting Lever Connecting Rod	1
27	606124	Lifting Lever Link Arm	1
28	606125	Hinge Screw	1
29	606126	Spring Screw	1
30	606127	Spring	1
31	606128	Screw	1
32	606117	Snap Ring	1
33	606130	Swivel	1
34	606131	Connecting Rod Nut	1
35	606132	Connecting Rod	1
36	606133	Finger Guard	1

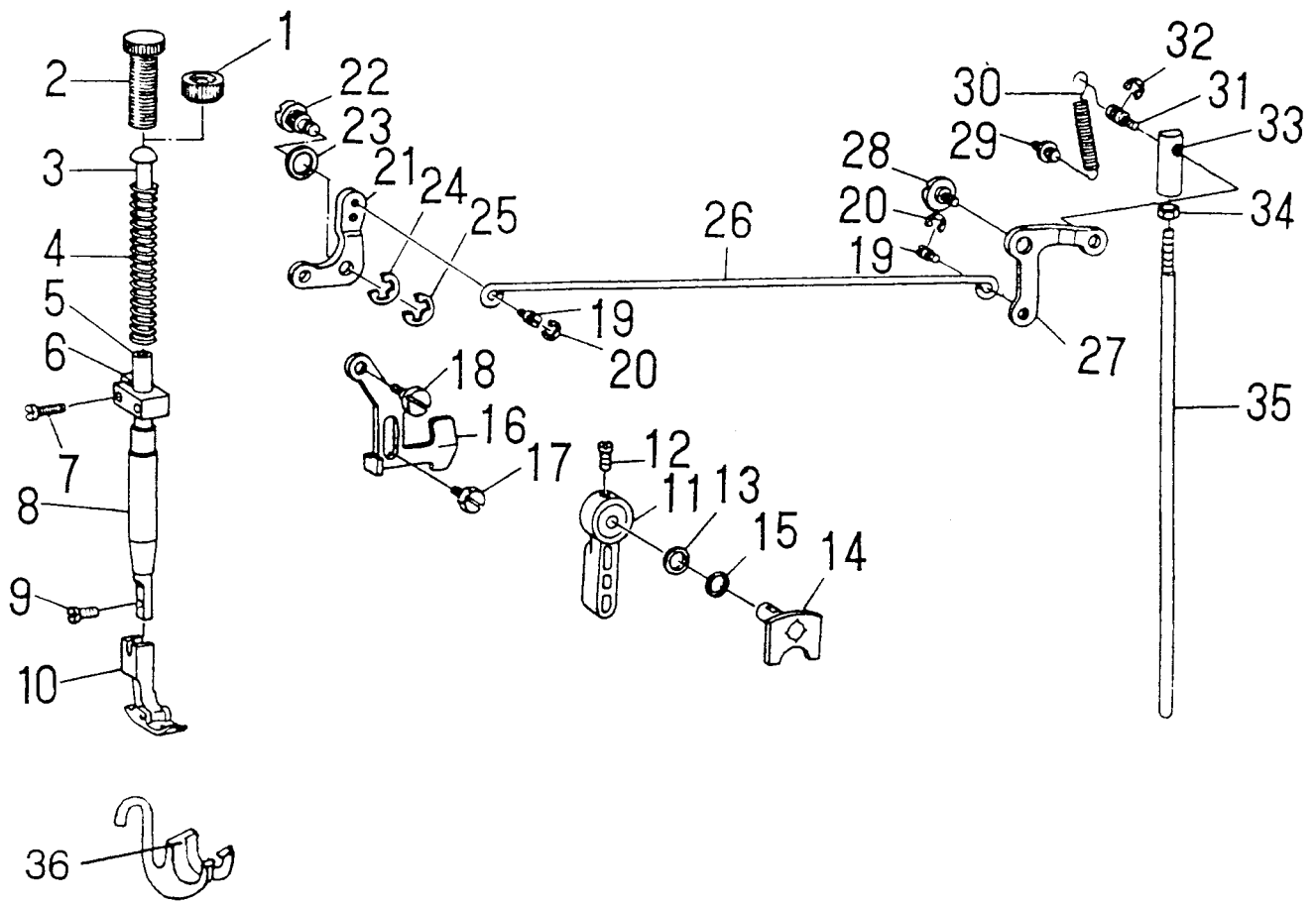

5. Hook Driving Shaft Components

<u>Ref. No.</u>	<u>Part No.</u>	<u>Description</u>	<u>QTY.</u>
1	606134	Bobbin Case assm.	1
2	606135	Bobbin	1
3	606136	Rotating Hook	1
4	606137	Screw	2
5	606138	Screw	2
6	606139	Thrust Collar	1
7	606140	Hook Driving Shaft Screw	1
8	606141	Oil Wick	1
9	606031	Screw	1
10	606143	Bushing (front)	1
11	606144	Bushing (intermediate)	1
12	606145	Hook Driving Shaft	1
13	606146	Thrust Collar	1
14	606138	Screw	2
15	606202	Screw	1
16	606149	Bushing (rear)	1
17	606150	Oil Felt	1
18	606151	Pinion assm.	1
19	606255	Screw	8
20	606153	Gear	1
21	606154	Upright Shaft	1
22	606155	Bushing (upper)	1
23	606156	Bushing (lower)	1
24	606031	Screw	2
25	606158	Gear	1
26	606159	Gear	1
27	606160	Positioning Finger	1
28	606161	Screw	1

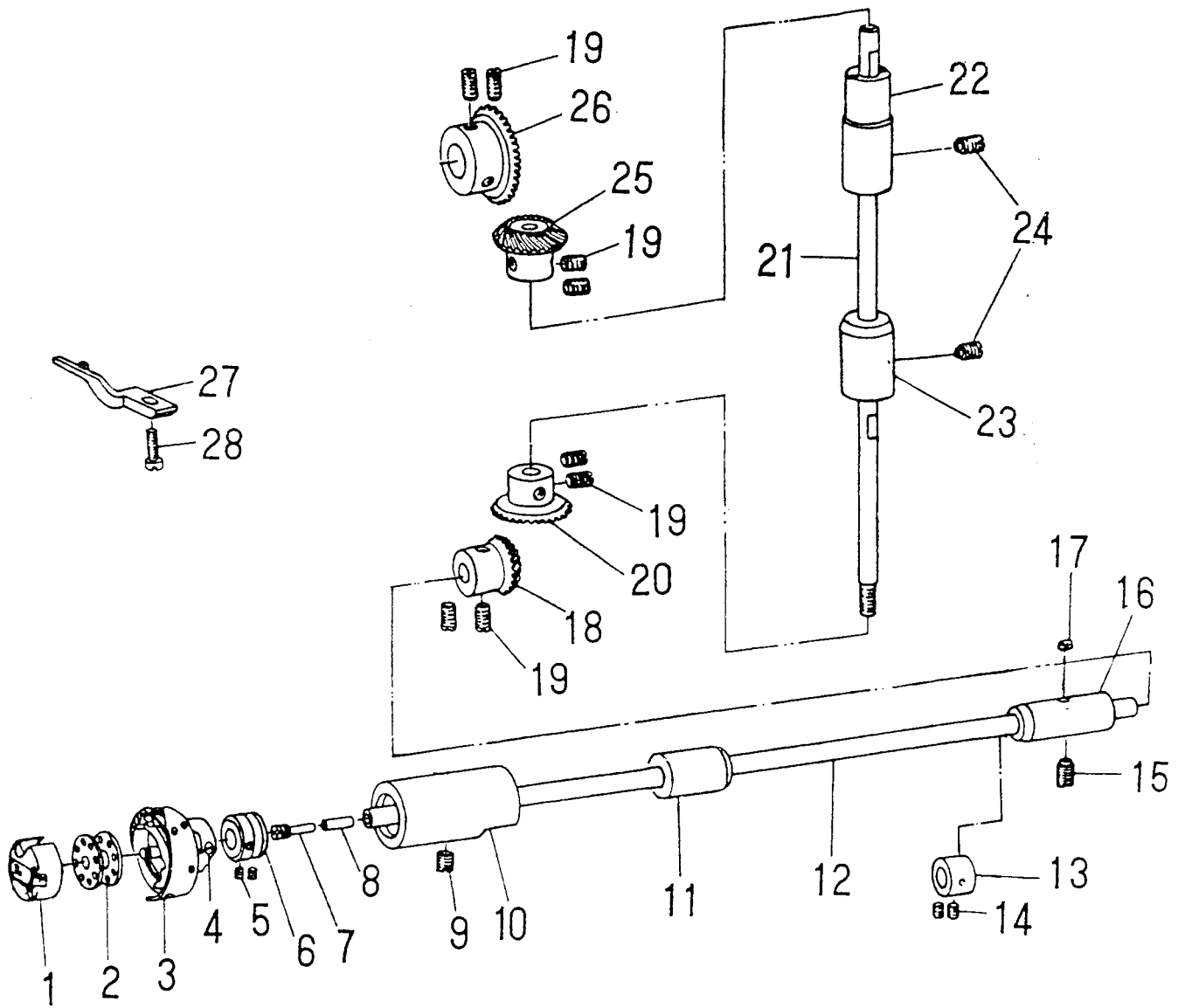

6. Feed Mechanism Components

<u>Ref. No.</u>	<u>Part No.</u>	<u>Description</u>	<u>QTY.</u>
1	606001	Throat Plate	1
2	606162	Screw	2
3	606163	Bed Slide assm.	1
4	606164	Spring	1
5	606165	Screw	2
6	606166	Screw	2
7	606000	Feed Dog	1
8	606167	Feed Bar assm.	1
9	606168	Shaft	1
10	606169	Oil Wick	1
11	606170	Screw	2
12	606171	Feed Rocker assm.	1
13	606172	Holder	1
14	606173	Screw	1
15	606174	Clamp Screw	1
16	606175	Washer	1
17	606176	Feed Rock Shaft	1
18	606177	Bushing (rear)	1
19	606209	Screw	1
20	606179	Feed Rock Shaft Crank	1
21	606213	Clamp Screw	1
22	606181	Hinge Screw	1
23	606215	Nut	1
24	606051	Thrust Collar	1
25	606211	Screw	2
26	606185	Bushing (rear)	1
27	606209	Screw	1
28	606187	C-Ring	1
29	606188	C-Ring	1
30	606189	Feed Driving Shaft Connecting Rod	1
31	606190	Feed Driving Eccentric	1
32	606191	Screw	2
33	606192	Feed Rock Shaft Connecting Rod	1
34	606193	Needle Bearing	1
35	606194	Feed Eccentric Thrust Washer	1
36	606195	Screw	3
37	606196	Connecting Rod	1
38	606197	Connecting Pin	1
39	606198	Screw	1
40	606199	Feed Driving Rocker Arm	1
41	606200	Feed Driving Shaft	1
42	606177	Bushing (rear)	1
43	606202	Screw	1
44	606203	Feed Rock Shaft Crank	1
45	606204	Screw	1
46	606205	Oil Wick	1
47	606206	Vinyl Tube	1
48	606187	C-Ring	1
49	606185	Bushing (rear)	1
50	606209	Screw	1
51	606051	Thrust Collar	1
52	606211	Screw	2
53	606212	Feed Driving Shaft Crank	1
54	606213	Clamp Screw	1
55	606181	Hinge Screw	1
56	606215	Nut	1
57	606216	Feed Driving Rocker	1
58	606217	Hinge Pin	1
59	606218	Screw	2
60	606219	Feed Driving Rocker Arm Hinge Pin	1
61	606220	Screw	1
62	606221	Hinge Stud	1
63	606204	Screw	1

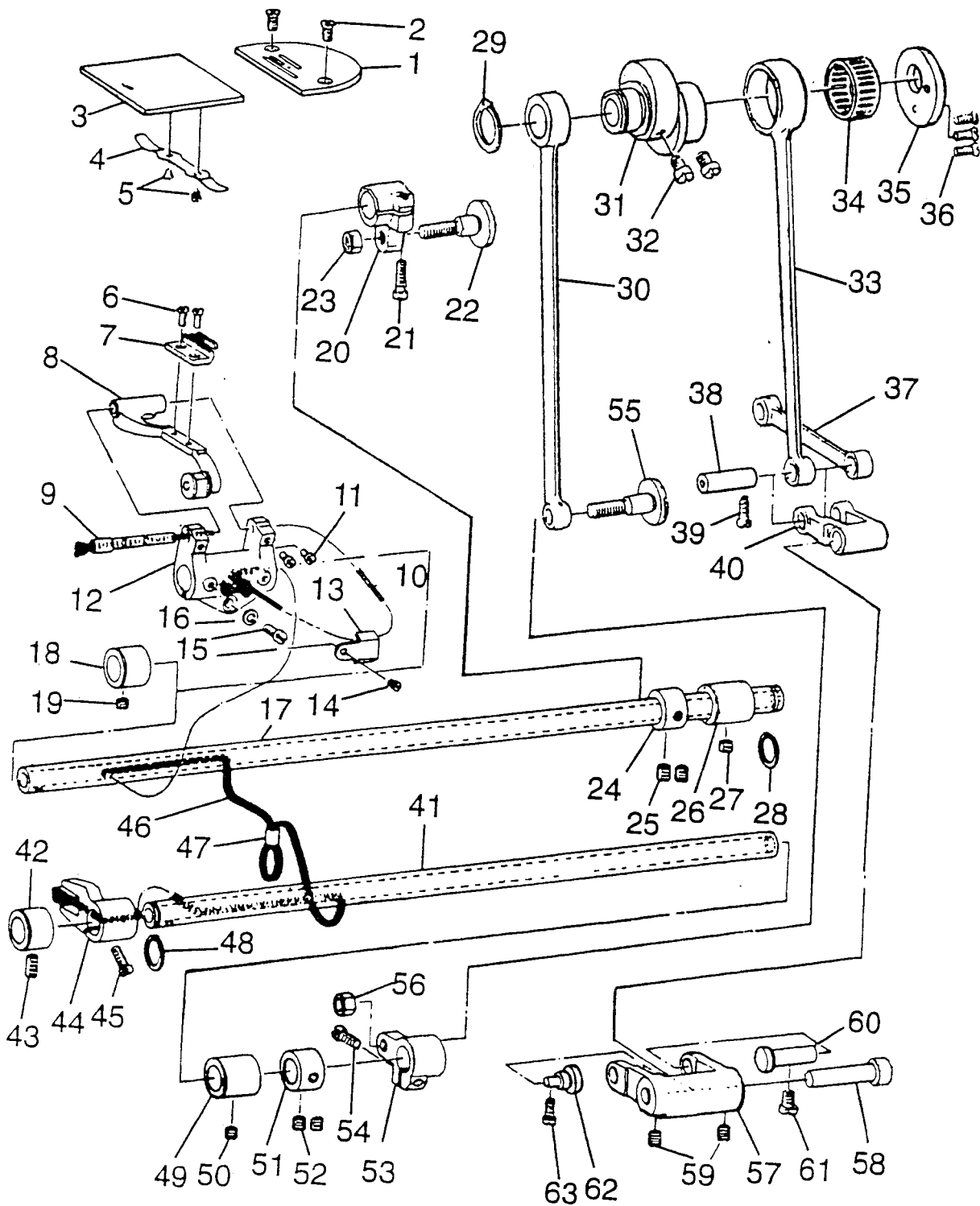

7. Feed Regulating Components

<u>Ref. No.</u>	<u>Part No.</u>	<u>Description</u>	<u>QTY.</u>
1	606223	Stitch Dial assm. Screw	1
2	606224	Stitch Dial assm.	1
3	606225	Feed Regulating Screw	1
4	606226	O-Ring	1
5	606227	Stitch Dial Lock Pin	1
6	606228	Stitch Dial Lock Spring	1
7	606229	Hinge Pin	1
8	606243	Screw	1
9	606231	Feed Regulator	1
10	606232	Feed Regulator Connecting Rod	1
11	606233	Hinge Screw	1
12	606253	Nut	1
13	606235	Tension Spring Stud	1
14	606236	Tension Spring	1
15	606237	Spring Bracket	1
16	606238	Screw	1
17	606239	Rubber Plug	1
18	606240	End Screw	2
19	606241	Tension Spring Crank	1
20	606249	Clamp Screw	1
21	606243	Screw	1
22	606011	Screw	1
23	606245	Feed Reverse Shaft	1
24	606246	Rubber Ring (large)	1
25	606247	Reverse Shaft Crank	1
26	606243	Screw	1
27	606249	Clamp Screw	1
28	606250	Feed Driving Rocker Arm Connecting Rod	1
29	606251	Hinge Screw	1
30	606252	Washer	1
31	606253	Nut	1
32	606254	Spring Washer	1
33	606255	Screw	1
34	606256	Screw	1
35	606257	Reverse Feed Lever	1

8. Lubrication Components

<u>Ref. No.</u>	<u>Part No.</u>	<u>Description</u>	<u>QTY.</u>
1	606258	Arm Oil Shield Screw	1
2	606259	Arm Oil Shield	1
3	606260	Oil Wick	1
4	606261	Oil Return Tube Holder	1
5	606262	Screw	1
6	606263	Oil Return Tube	1
7	606264	Oil Felt Retainer	1
8	606265	Oil Felt	1
9	606266	Oil Felt	1
10	606262	Screw	1
11	606268	Plunger Thrust Plate	1
12	606269	Plunger Spring	1
13	606270	Oil Return Pump Plunger	1
14	606271	Connecting Screw	1
15	606272	Oil Sight Window	1
16	606273	O-Ring	1
17	606274	Main Shaft Oil Tube	1
18	606275	Oil Pump assm.	1
19	606276	Oil Pump Base	1
20	606277	Rubber Connection	1
21	606278	Rubber Connection	1
22	606279	Oil Pump	1
23	606280	Oil Pump Impeller	1
24	606281	Oil Pump Impeller Cover	1
25	606282	Screw	3
26	606283	Washer	3
27	606284	Nut	3
28	606285	Oil Pump Cover	1
29	606286	Screw	5
30	606287	Screw	3
31	606288	Oil Tube	1
32	606289	Spring	1
33	606290	Oil Adjusting Screw	1

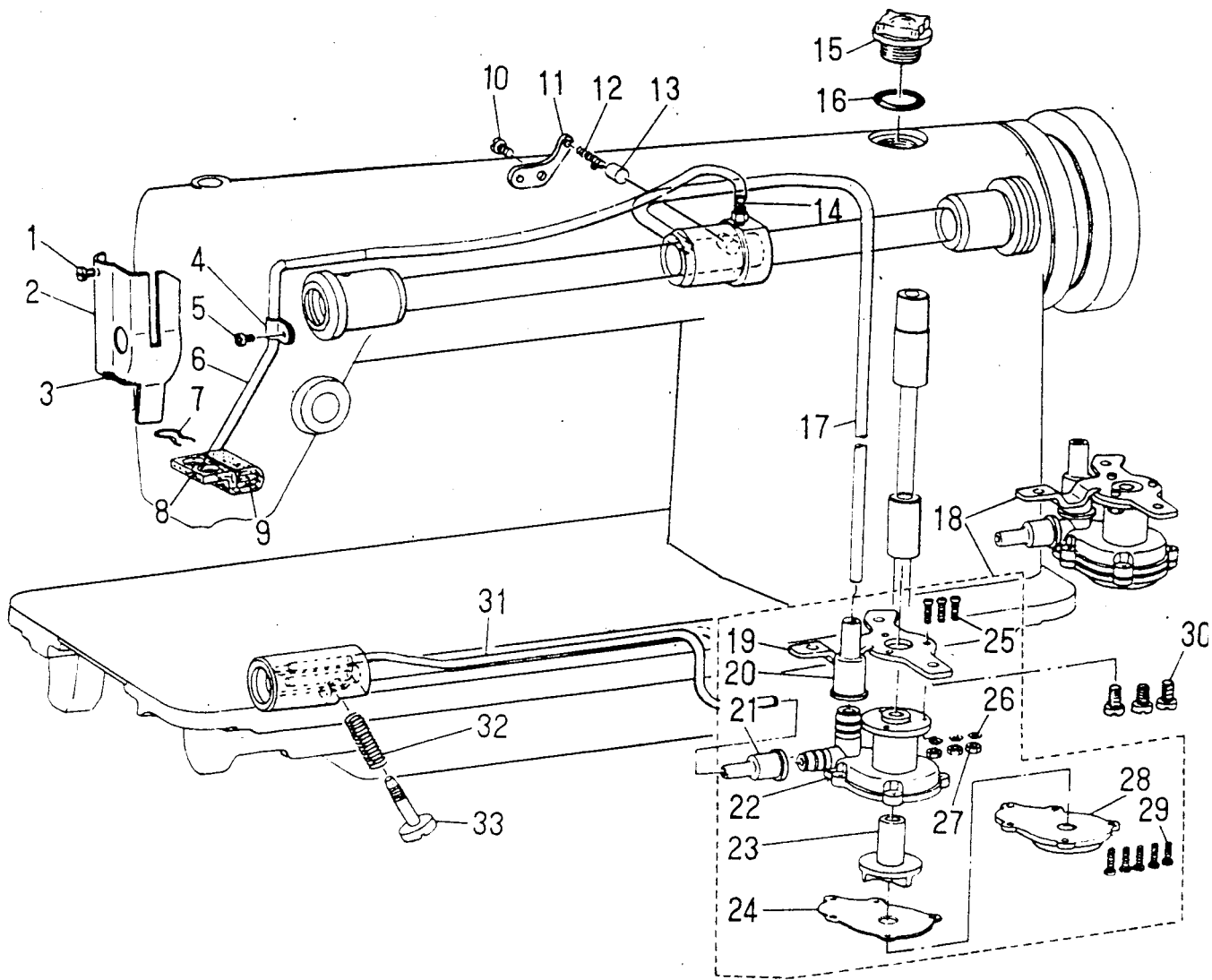

9. Oil Reservoir and Knee Lifter Components

<u>Ref. No.</u>	<u>Part No.</u>	<u>Description</u>	<u>QTY.</u>
1	606291	Oil Reservoir assm.	1
2	606292	Gasket	1
3	606293	Oil Reservoir Rubber Cushion	2
4	606294	Oil Reservoir Felt Cushion	2
5	606295	Rubber Cushion	4
6	606296	Nail	4
7	606297	Knee Press Lifting Rod	1
8	606298	Oil Reservoir Magnet	1
9	606058	Oil Drain Screw	2
10	606300	Oil Drain Cap Gasket	2
11	606301	Lifting Crank	1
12	606302	Positioning Screw	1
13	606303	Nut	1
14	606304	Positioning Screw	1
15	606303	Nut	1
16	606305	Lifting Crank Screw	1
17	606306	Spring	1
18	606307	Thrust Ring	1
19	606308	Knee Lifter Shaft	1
20	606309	Bearing Bracket	1
21	606310	Clamp Screw	1
22	606311	Knee Lifter Plate Rod	2
23	606312	Knee Press Plate Cover Joint	1
24	606042	Screw	1
25	606314	Knee Press Plate Spring	1
26	606315	Knee Press Plate assm.	1
27	606316	Screw	1
28	606317	Knee Press Plate Cover	1

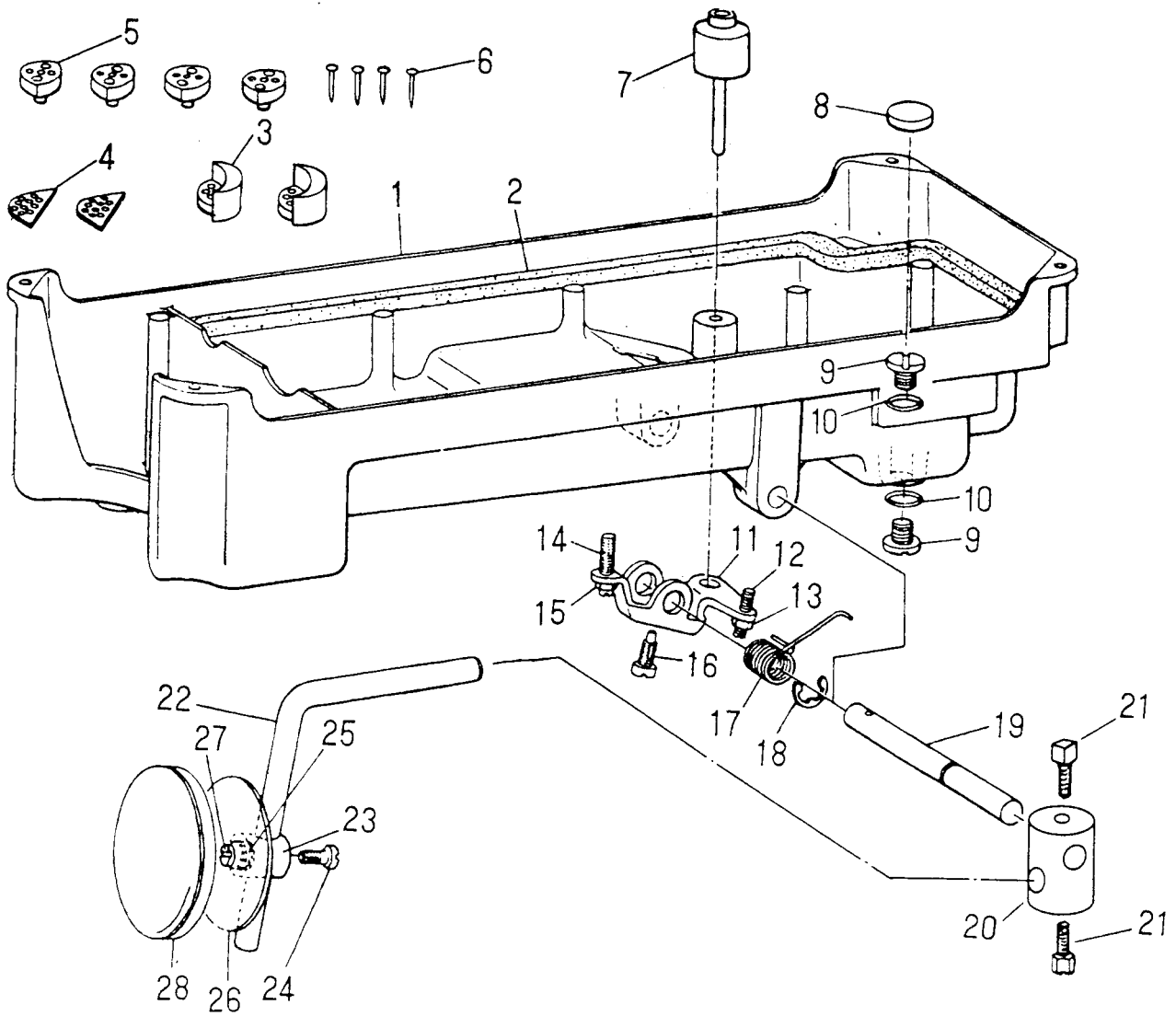

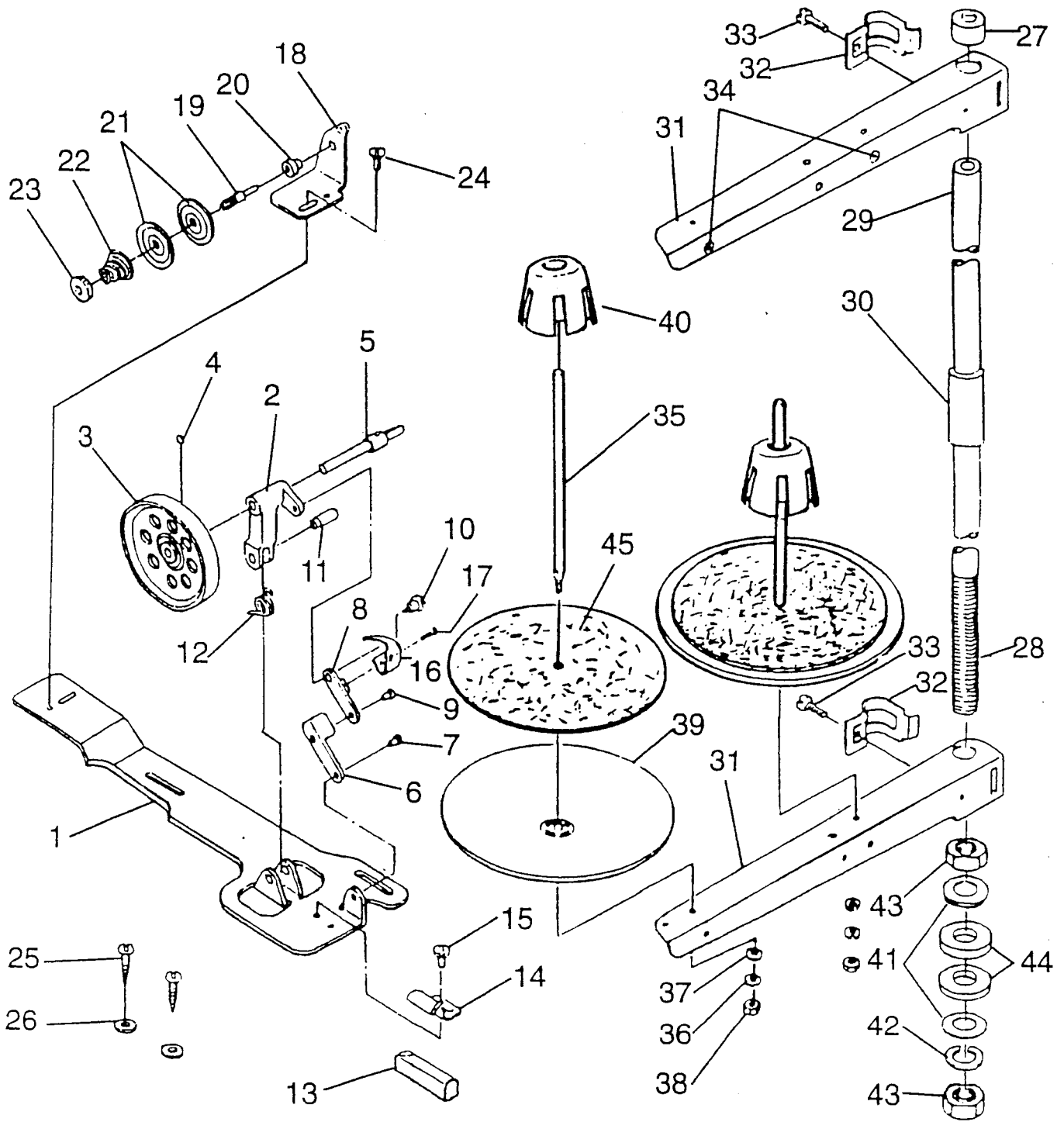

11. Machine Head Accessories

<u>Ref. No.</u>	<u>Part No.</u>	<u>Description</u>	<u>QTY.</u>
1	606362	Screw Driver (S)	1
2	606363	Screw Driver (M)	1
3	606364	Screw Driver (L)	1
4	606135	Bobbin	3
5	N2270#14	Needle	1 pack
6	606366	Oil Container	1
7	606367	Machine Rest Pin	1
8	606368	Machine Hinge Plate	2
9	606296	Nail	4
10	606370	Machine Hinge Plate assm.	2
11	606371	Belt Cover Support Stud	1
12	606372	Belt Cover (A)	1
13	606373	Screw	2
14	606374	Washer	2
15	606375	Belt Cover (B) Insert	1
16	606376	Nut	1
17	606377	Screw	1
18	606378	Belt Cover (B)	1
19	606341	Wood Screw	2
20	606342	Washer	2
21	606381	Machine Head Cover	1

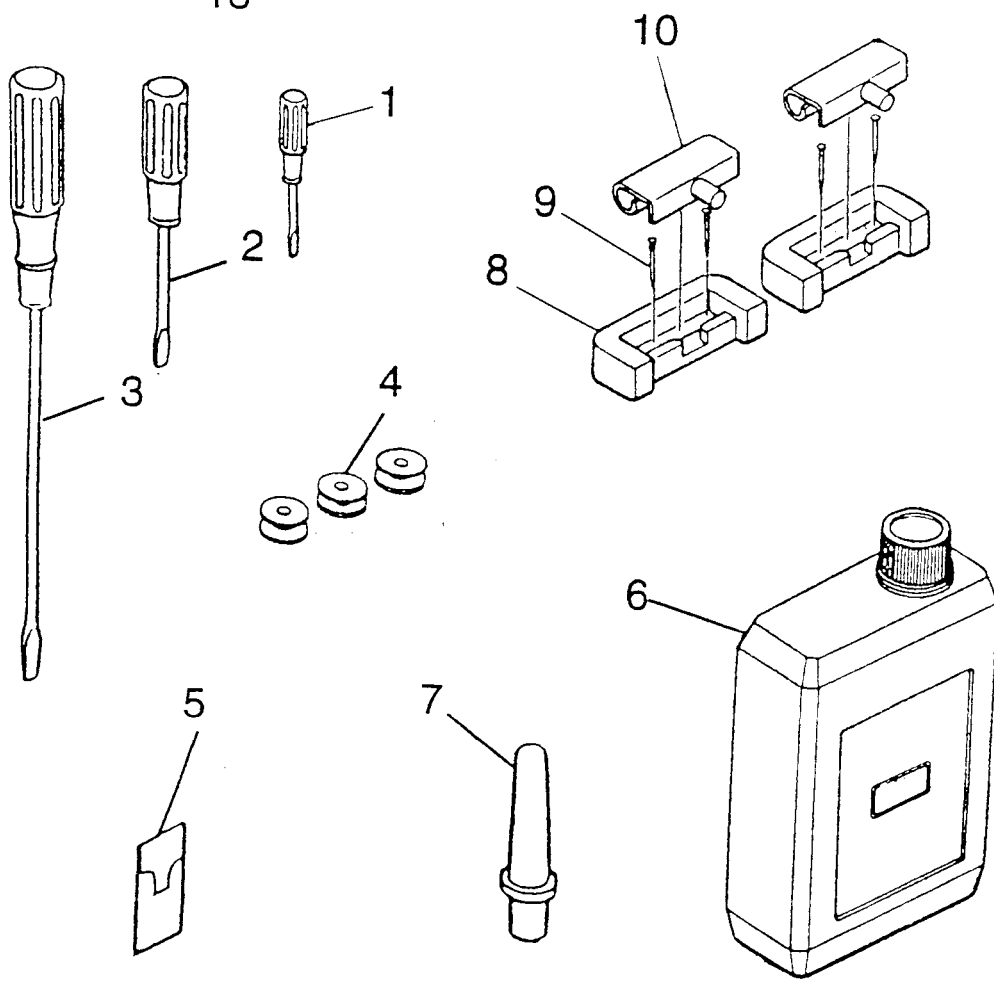
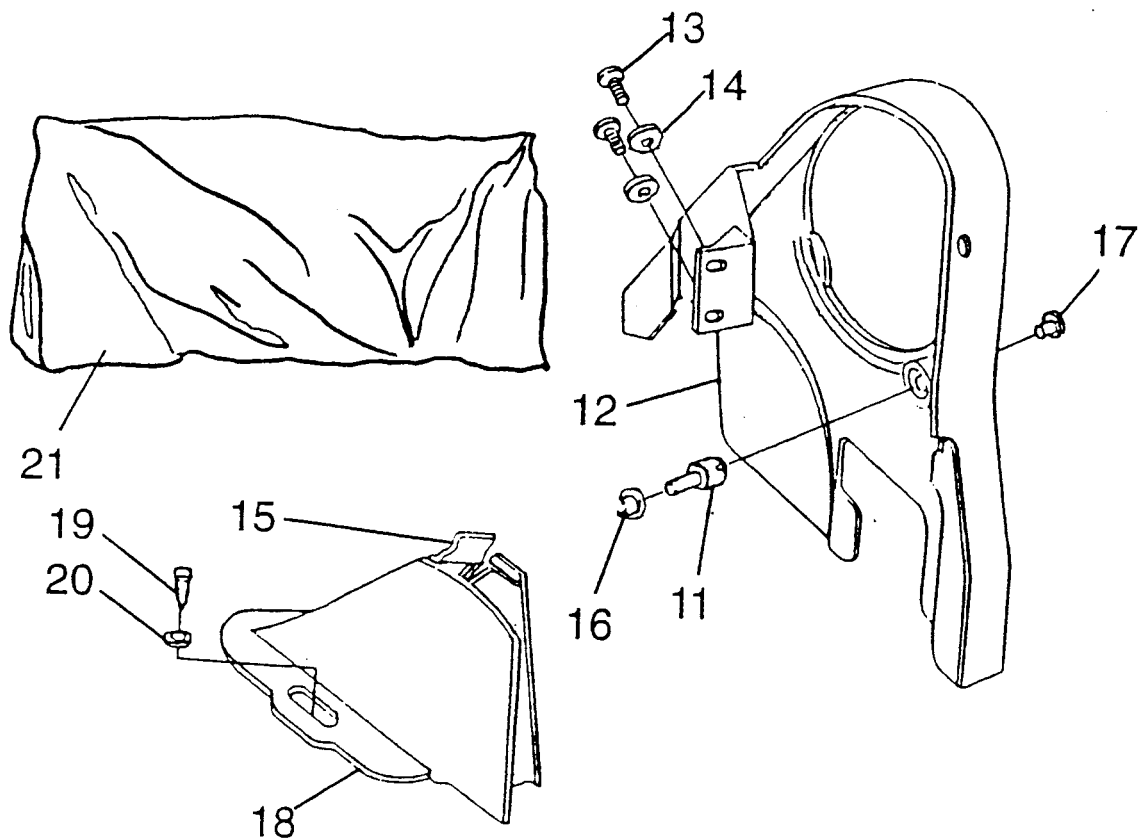

Model 2191D300A (for Medium to Heavy Weight Material)

<u>Ref. No.</u>	<u>Part No.</u>	<u>Description</u>	<u>QTY.</u>
1	606382	Counterweight assm.	1
2	606383	Needle Bar Crank	1
3	606384	Needle Bar Bushing (lower)	1
4	606385	Thread Guide	1
5	606386	Needle Bar	1
6	N2270#18	Needle	1
7	606387	Thread Guide (right)	1
8	606388	Tension Spring	1
9	606389	Thread Guide Pin	1
10	606390	Presser Bar Spring	1
11	606005	Presser Foot	1
12	606391	Hook Driving Shaft Screw	1
13	606392	Feed Driving Eccentric	1
14	606003	Feed Dog	1
15	606004	Throat Plate	1
16	606393	Stitch Dial assm.	1
17	606394	Arm Oil Shield Screw	1
18	606630	Model Plate	1

