

SINGER

177-2

USE ONLY
SINGER

“OIL FOR HIGH SPEED SEWING MACHINES
(Cloth and Leather)”

for general use

or

“STAINLESS OIL
FOR HIGH SPEED SEWING MACHINES”

where a stainless oil is desired.

These specially prepared oils are the result of extensive research. They ensure freedom from lubricating trouble and give longer life to sewing machines.

**THE IMPORTANCE OF USING
SINGER NEEDLES FOR
SEWING MACHINES**

The best stitching results will be obtained by using the needles furnished by the Singer Sewing Machine Company.

Singer Needles can be purchased from any Singer Shop for the Manufacturing Trade.

Genuine Singer Needles should be used
in Singer Machines.
These Needles and their Containers
are marked with the
Company's Trade Mark "SIMANCO." 1

Needles in Containers marked
"For Singer Machines"
are not Singer made needles. 2

Copyright, U. S. A., 1914, 1915, 1935, and 1936,
by The Singer Manufacturing Company
All Rights Reserved for all Countries

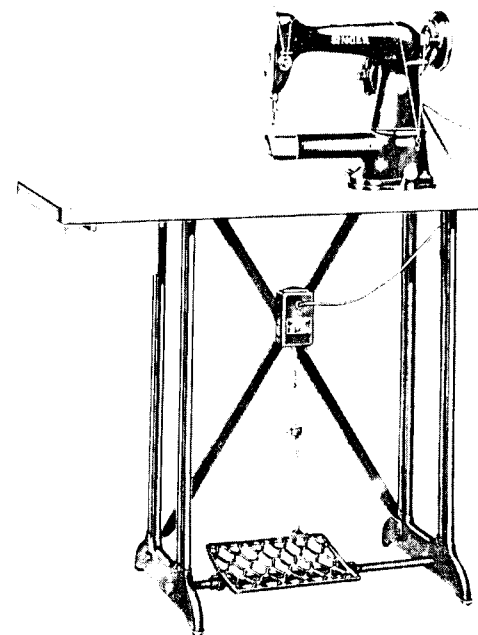

Machine 177-2 on
Table 29637 and Stand 46915

DESCRIPTION

MACHINE 177-2 has one needle and one shuttle, and makes the lock stitch for darning and mending towels, barbers' coats and many other articles. It has a cylinder 2 inches in diameter and there is a clearance of 7 1/2 inches from the needle to the base of the arm.

Flat Work Plate 176605 is furnished, on order, at an additional charge and can be easily applied to the cylinder so that all kinds of flat work such as tablecloths, napkins, towels, aprons, sheets, lace curtains, etc., can be quickly darned and mended.

Unless otherwise specified on the order, the machine will be furnished with a B. U. 307 motor for 25 to 75 cycles, 100 to 110 volts, alternating current. The motor can also be operated on a direct current of 100 to 110 volts.

To Oil the Machine

When the machine is received from the factory, it should be thoroughly cleaned and oiled. At least once a day, apply oil to

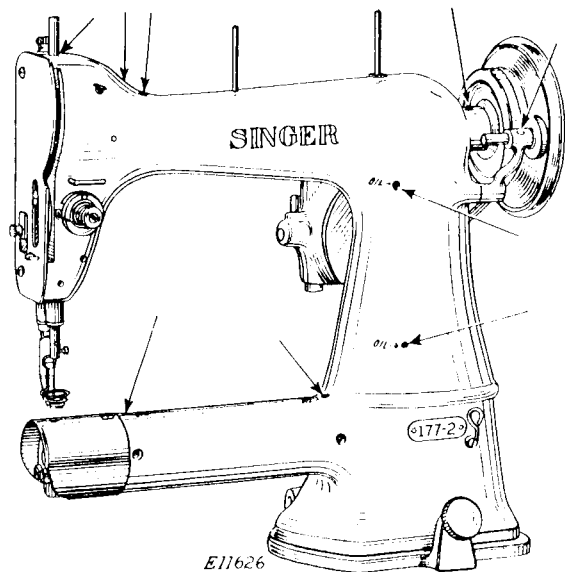

Fig. 2

all holes marked "OIL" and other places designated by arrows in Fig. 2. Remove the face plate and oil the parts indicated by arrows without references in Fig. 15. BE SURE to put a drop of oil daily in the raceway of the hook. The hook is the part which revolves around the bobbin case.

Use only Singer Motor Lubricant for lubricating the motor. When the machine is shipped from the factory, the two motor grease cups are filled with sufficient Singer Motor Lubricant for approximately six months' use, under ordinary circumstances.

At least once every six months thereafter, these grease cups should be refilled with the Singer Motor Lubricant. To do this, insert the tip of the motor lubricant tube into the grease cups (BB, Fig. 3) and squeeze into each cup a small amount of the lubricant.

To Adjust the Belt Tension

The tension on the belt should be just sufficient to keep the belt from slipping.

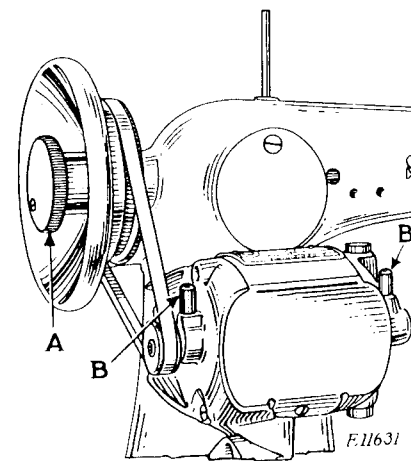

Fig. 3

To obtain the correct belt tension, loosen the screw which fastens the motor to the machine and move the motor downward for more tension, or upward for less tension. Then tighten the screw.

To Clean the Stitching Mechanism

At frequent intervals, depending upon how much the machine is being used, it is necessary to remove the accumulated thread or lint from the hook and bobbin case.

With a screwdriver, take out the screw holding the nickelled cap on the end of the cylinder of the machine, slide the cap off and clean out the accumulated lint and thread. Put the cap back and screw it tight after cleaning. Be sure to keep the machine clean and it will give excellent service.

Needles

Needles for Machine 177-2 are of Class and Variety 177xl and are furnished in sizes 12,14,16,18 and 20.

The size of the needle to be used should be determined by the size of the thread which must pass freely through the eye of the needle. If rough or uneven thread is used, or if it passes with difficulty through the eye of the needle, the successful use of the machine will be interfered with. Use the same size thread in both needle and bobbin.

Orders for needles must specify the QUANTITY required, the SIZE number, also the CLASS and VARIETY numbers separated by an x.

The following is an example of an intelligible order:

"100 No. 16, 177xl Needles."

The best results will be obtained when using the needles furnished by the Singer Sewing Machine Company.

Thread

Use left twist thread in the needle and bobbin.

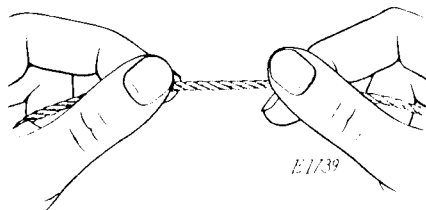

Fig. 4

Hold the thread as shown above. Turn the thread over toward you between the thumb and forefinger of the right hand; if left twist, the strands will wind tighter; if right twist, the strands will unwind.

To Set the Needle

Raise the needle bar to its highest point, loosen the needle clamp screw (C, Fig.5) and push the needle up into the bar as far as it will go with its long groove toward the left and the eye of the needle directly in line with the cylinder bed of the machine, then tighten the screw (C).

Never leave the needle clamp screw loose or the needle partly out of its socket in the needle bar. When inserting a new needle, be sure it is perfectly straight.

Upper Threading

Place the spool of thread on spool pin (1, Fig.5), then pass the thread through the thread guide (2), down, under and from

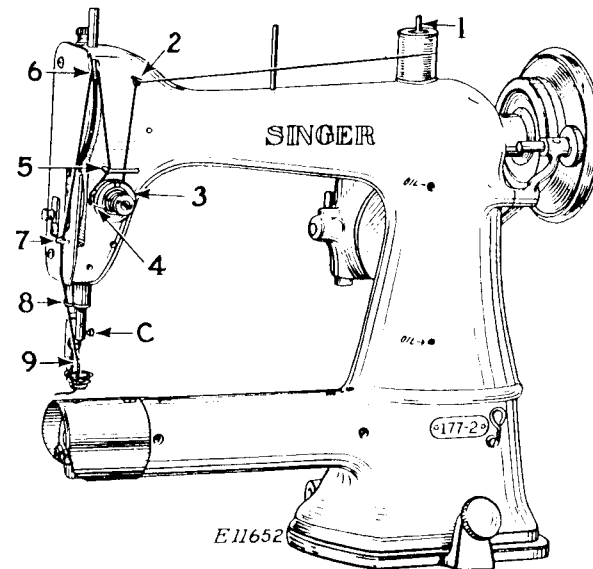

Fig. 5

right to left between the tension discs (3). With the right hand hold the spool to prevent it from turning, and with the left hand draw the thread up into the take-up spring (4) until the thread enters the retaining fork, then pass the thread up and into the thread guide (5), from right to left through the thread take-up lever (6), down through the thread guides (7 and 8) and from LEFT TO RIGHT through the eye of the needle (9).

To Remove the Bobbin

Turn the balance wheel by hand to raise the take-up (D, Fig. 6) to its highest point. Remove any work there may be in the machine and cut the thread. Raise the latch lever located just under the nickelled tubular cap, which will then release and open the latch, and the bobbin case can be easily lifted out.

To Wind the Bobbin

Lift the bobbin retaining latch and remove the bobbin from the bobbin case. Place the bobbin on the bobbin winder spindle and push it on as far as it will go.

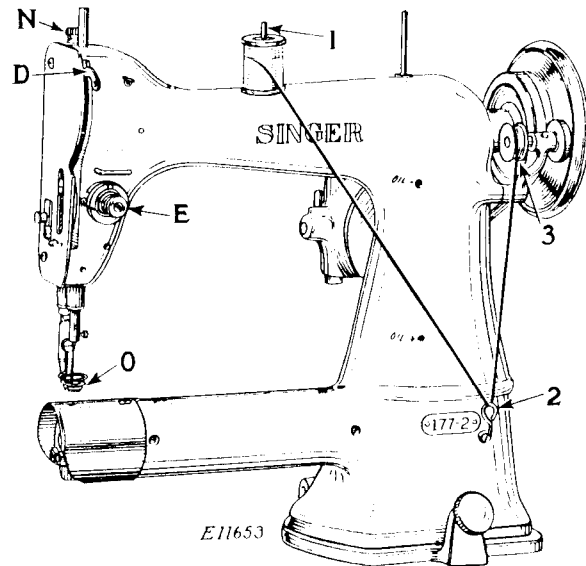

Fig. 6

Place the spool of thread on the spool pin (1), pass the thread down and through the guide (2), then up to the bobbin (3). Wind a few turns of thread around the bobbin and push the bobbin winder against the belt.

Loosen the thumb screw (A, Fig. 3) on the balance wheel, and press on the speed controller. Be sure to run the machine at moderate speed while winding the bobbin. Do not forget to tighten the thumb screw (A, Fig. 3) before attempting to sew.

To Thread the Bobbin Case

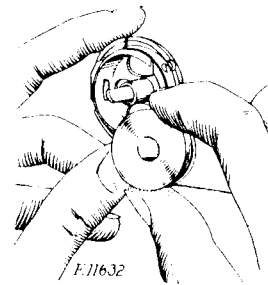

Fig. 7

With the left hand hold the bobbin case as shown in Fig. 7, the slot in the edge being near the top, and place the bobbin into it. Close the retaining latch.

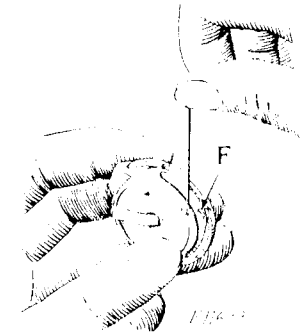

Fig. 8

Full the thread into the slot in the edge of the bobbin case (see Fig. 8), draw the thread under the tension spring and into the delivery eye as shown in Fig. 9.

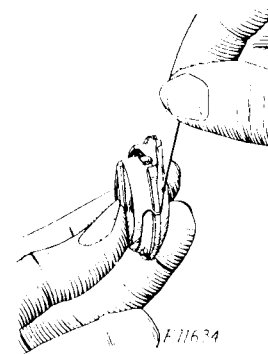

Fig. 9

Arrow in Fig. 8 indicates direction in which the bobbin should turn when unwinding.

To Replace the Bobbin Case

When replacing the bobbin case in the machine, have the take-up at its highest point. Be sure that the tip of the bobbin case is placed in the correct position so that it fits into the recess of the bobbin case latch. The latter will not close or latch until the bobbin case is correctly inserted.

To Regulate the Tension

Perfect stitching depends largely upon using the correct sizes of needle and thread, the proper adjustment of tensions, and the skill with which the work is guided through the machine.

On all stitching that is properly done, the threads will be drawn together and locked in the center as in Fig.10.

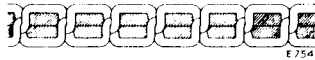

Fig. 10

If the thread should be straight along the under side of the goods, as in Fig.11, either the bobbin case tension is too tight, or the upper tension too loose.



Fig. 11

If the thread appears straight along the upper side of the fabric, as in Fig. 12, then the upper tension is too tight, or the bobbin case tension is too loose.

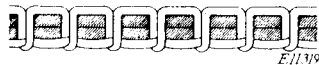

Fig. 12

The upper or needle thread tension can be tightened by turning the thumb screw (E, Fig.6) to the right, or loosened by turning this thumb screw to the left.

In most cases, adjustment of the upper tension is all that is required. However, if this does not produce the desired results, then the bobbin case tension needs adjustment. Using a small screwdriver, tighten the tension screw (F, Fig.8) on the bobbin case for more tension, or loosen the screw for less tension.

To Begin Sewing

After threading the machine and bobbin case, raise the presser foot (O, Fig.6) and turn the balance wheel slowly towards you with the right hand, holding onto the needle thread with the left hand. Keep on turning the balance wheel slowly, permitting the needle to descend and then rise, until the lower thread is drawn upward through the hole in the needle plate. Lay both threads under the presser foot, place the fabric under the foot, lower the foot and you are ready to darn or sew.

For practising the darning movement, use a few sewing rags in the beginning. Lift up the presser foot, putting the work under the foot at the place to be darned. Then lower the presser foot and apply slight pressure to the electric motor controller. You will note, as the machine starts to operate, that the presser foot will lift up at each stitch just as the needle is coming out of the throat plate. This is the correct time to move your goods forward, backward, or to the side. Of course, with a machine at high speed operation, the foot is being elevated very fast so it is necessary to get the hand motion for darning at about the same speed as the machine is operated. Go slow at first. After you learn to handle the machine you can darn or sew as fast as you wish.

Always, when darning a hole, be sure to first put one or two rows of stitching about 1/8 of an inch from the edge of the hole. After this is done keep on all the way across the hole, moving the work forward or backward until the entire hole is covered with straight lines of stitching close together. Now move the work from side to side so as to make rows of stitching across the stitching previously done, until the hole is completely darned.

It is best to use both hands in guiding the work. The feeding and length of stitch depends entirely on how the work is handled, or in other words, you must help the machine to carry the work through.

When sewing up a tear, or making a straight seam on garments or flat pieces, remember to help the work along and keep it moving at all times. With a little practise it will be an easy matter to do satisfactory work.

Flat Work Plate 176605, which is furnished at extra charge, can be easily applied to the cylinder so that all kinds of flat work such as tablecloths, towels, sheets, etc., can be quickly darned and mended.

In darning flat work it is advisable to use an embroidery hoop to hold the work.

To Set the Presser Bar

Lower the presser bar and needle bar and turn the presser foot regulating screw so that the block (G) is in the position shown in Fig.13. If the presser bar is set correctly, two thicknesses of material can be freely moved beneath the presser foot.

To set the presser bar, loosen screw (J, Fig.15) and move the presser bar up or down, as required. Then tighten screw (J). The presser bar should never be so low as to rest on the needle plate.

To Adjust the Thread Clearance Around the Bobbin Case

There should be just enough clearance between the bobbin case and the latch so that the largest size of thread ordinarily

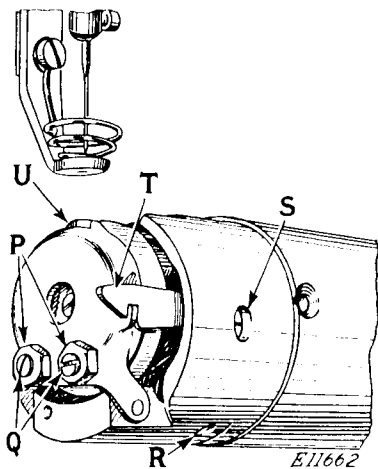

Fig. 16

used will slip around the bobbin case freely. Too much clearance will be a source of noise.

Loosen the two lock nuts (P) and adjust the screws (Q) until there is just enough room for the thread to pass easily under the rounded points of the screws. The clearance at the top of the latch (U) may be adjusted by loosening the set screw (R) and turning the eccentric screw (S) to move the latch lever (T) in or out until the latch is in the correct position.

Genuine Singer Needles should be used
in Singer Machines.
These Needles and their Containers
are marked with the
Company's Trade Mark "SIMANCO." 1

Needles in Containers marked
"For Singer Machines"
are not Singer made needles. 2