

SINGER
112W145,W146,W147

USE SINGER[®] OILS and LUBRICANTS

They insure freedom from lubricating trouble and give longer life to sewing equipment

The following are the correct lubricants for this machine:

TYPE B — MANUFACTURING MACHINE OIL, HEAVY GRADE

When an oil is desired which will produce a minimum of stain on fabrics, even after a long period of storage, use:

TYPE D — MANUFACTURING MACHINE OIL, HEAVY GRADE

OTHER SINGER LUBRICANTS

TYPE E — THREAD LUBRICANT

For lubricating the needle thread of sewing machines for stitching fabrics or leather where a thread lubricant is required.

TYPE F — MOTOR OIL

For oil lubricated motors and plain bearings in power tables and transmitters.

NOTE: All of the above oils are available in 1 quart, 1 gallon and 5 gallon cans.

GEAR LUBRICANT

This specially prepared grease is recommended for gear lubrication on manufacturing sewing machines.

BALL BEARING LUBRICANT

This pure grease is specially designed for the lubrication of ball bearings and ball thrust bearings of motors and electric transmitters, ball bearing hangers of power tables, etc. Furnished in 1 lb. and 4 lb. tins.

INSTRUCTIONS

FOR USING AND ADJUSTING

SINGER[®] SEWING MACHINES

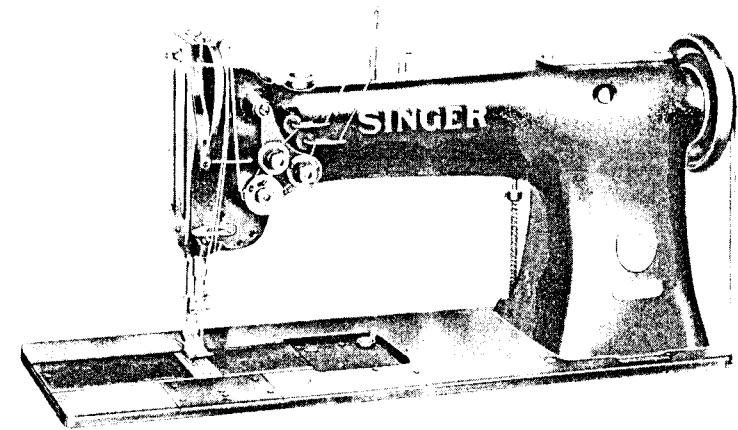

Machine 112w145

112w145, 112w146
and 112w147

THE SINGER MANUFACTURING COMPANY

DESCRIPTION

MACHINE 112W145 has two needles and two belt-driven rotary hooks and makes two parallel rows of lock stitching in light and medium weight fabrics such as shirts, smocks, underwear, overalls, etc. The machine has a drop feed.

The machine may be furnished in gauges from $1/32$ to $1-1/2$ inches, as ordered.

MACHINE 112W146 is similar to Machine 112W145 except that it is designed for vamping, foxing, space stitching, tipping and other operations on shoes, also for gloves and general leather work. It has a ball bearing roller presser and may be furnished in gauges $1/32$ to $1/4$ inch.

MACHINE 112W147 is similar to Machine 112W145 except it is fitted with staying presser foot, stay guide and strip reel for staying shoes. The machine may be furnished in gauges $3/32$ to $1/2$ inch.

Copyright © 1940 by The Singer Manufacturing Company

Speed

The machines should be driven at a speed not exceeding 3000 revolutions per minute for the first two or three days, after which they can be driven up to their maximum speed of 3500 revolutions per minute, according to the material being stitched and the continuity of operation of the machine. When the machines are in operation, the top of the machine pulley must turn toward the operator.

CAUTION:

After setting up, do not start a machine, not even to test the speed, until it has been thoroughly oiled, as instructed on pages 4 and 5.

To Oil the Machine

When the machine is received from the factory, it should be thoroughly cleaned and oiled.

Use "TYPE B" or "TYPE D" OIL, sold only by Singer Sewing Machine Company. For description of these oils, see inside front cover.

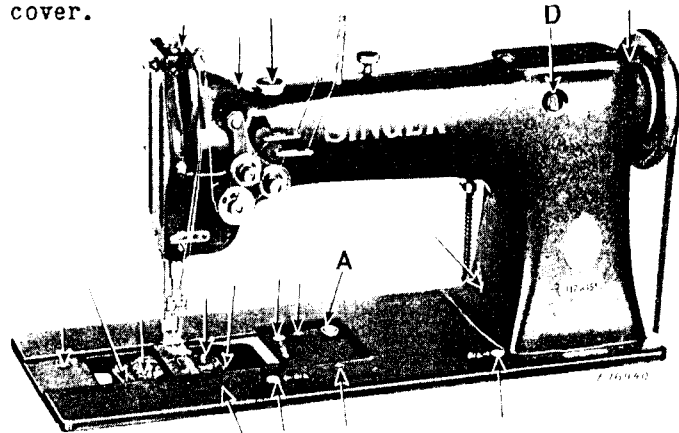

Fig. 2. Oiling Points at the Front of the Machine

All parts of these machines can be oiled without turning the machine back on its hinges. Oil should be applied at each of the places designated by arrows in Figs. 2, 3, 4 and 5. When a machine is in continuous use, it should be oiled at least twice a day. A new machine in continuous use, on long runs should be oiled more frequently. Pull out the attachment slide in front of the needles and oil the feed rock shaft through the large hole in the bed.

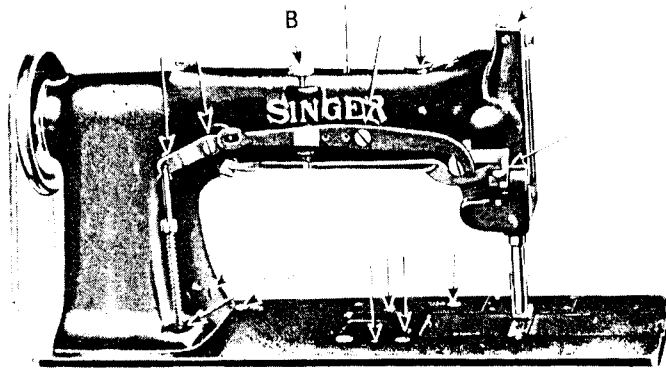

Fig. 3. Oiling Points at the Back of the Machine

Loosen the thumb screw in the upper end of the face plate, turn the face plate upward and oil the wick and moving parts which are

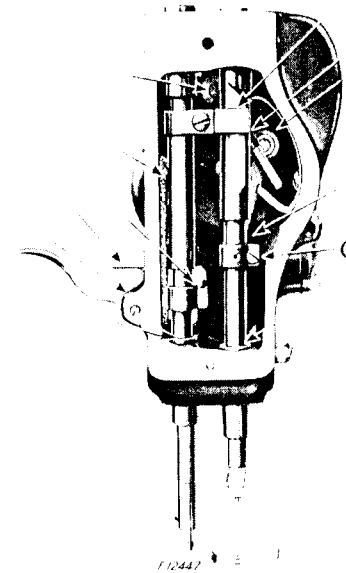

Fig. 4. End View of Machine, Showing Oiling Points

thus uncovered, then turn down the face plate and tighten the thumb screw.

HOOK LUBRICATION. The "X-ray" view, Fig. 5, shows the means for oiling the ball bearing hook saddles. Oil should be placed in the oil well (F, Fig. 5), from whence it will flow to both upper and lower bearings and also will lubricate the mechanical opener mechanism.

The small green felt pads (G, Fig. 7) on the side of each bobbin case should be kept wet with oil to lubricate the hook races. When these pads are wet they appear nearly black, and when they appear light green it indicates that they are dry. When a machine is new oil should be applied to these felt pads each time a bobbin is replaced.

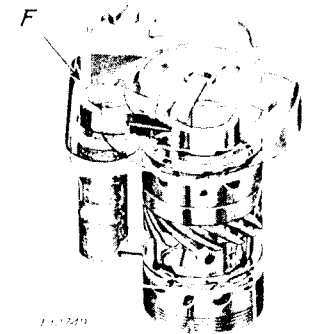

Fig. 5. Hook Lubrication

Needles

Needles for these machines are of the following Class and Variety numbers:

Machine	Class and Variety	Sizes
112W145	135x7	7,8,9,10,12,14,16,18,20,22 and 24
112W146 112W147	135x6	10,11,12,13,14,15,16,18,20,22,23 and 24

The size of the needles to be used should be determined by the size of the thread, which must pass freely through the eye of the needles. If rough or uneven thread is used or if it passes with difficulty through the eye of the needles, the successful use of the machine will be interfered with. Use smooth finish thread.

Orders for needles must specify the quantity required, the size number, also the class and variety numbers separated by the letter X.

The following is an example of an intelligible order:
"100 No. 14, 135x7 Needles."

The best results will be obtained in using the needles sold by the Singer Sewing Machine Company.

Thread

Use left twist thread for both needles. Either left or right twist thread may be used for the bobbins:

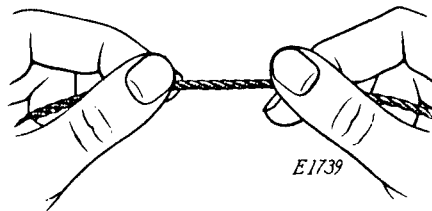

Fig. 6. How to Determine the Twist

Hold the thread as shown above. Turn the thread over toward you between the thumb and the forefinger of the right hand; if left twist, the strands will wind tighter; if right twist, the strands will unwind.

Relative Sizes of Needles and Thread

Size Numbers of Needles	Cotton Thread	Silk Thread
10	100 to 150	000 to 00
11	90 " 100	00
12	80 " 90	0
13	70 " 80	A
14	60 " 70	A
15	50 " 60	B
16	40 " 50	C
18	30 " 40	C
20	24 " 50	D
22	16 " 24	E

To Set the Needles

Loosen the set screws in the needle holder and put the needles up into the holder as far as they will go, with the long grooves of the needles facing each other, then securely tighten the set screws.

To Remove the Bobbins

Draw out the slide plates in the bed of the machine. Turn the machine pulley over toward you until the needle bar moves up to its highest point. Place the thumb or finger under the bobbin case latches as shown in Fig. 7, raise the latches and lift out the bobbins.

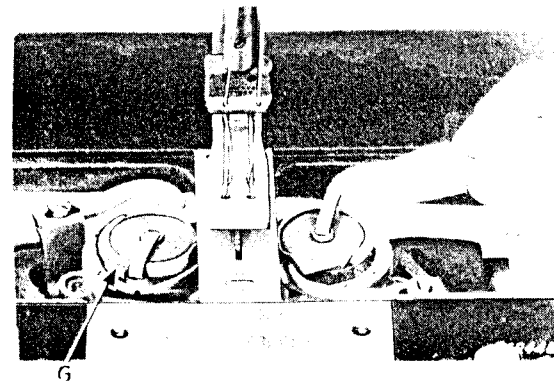

Fig. 7. Removing the Bobbins

To Wind the Bobbin

(See Fig. 8)

Fasten the bobbin winder to the table with its driving pulley in front of the machine belt, so that the pulley will drop away from the belt when sufficient thread has been wound upon the bobbin.

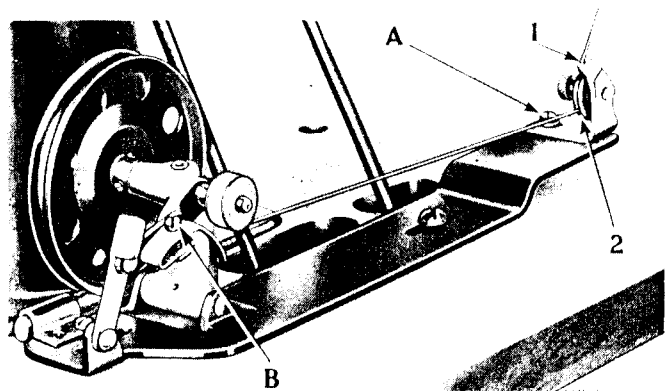

Fig. 8. Winding the Bobbin

Place the bobbin on the bobbin winder spindle and push it on as far as it will go.

Pass the thread down through the thread guide (1) in the tension bracket, around the back and between the tension discs (2). Then wind the end of the thread around the bobbin a few times, push the bobbin winder pulley over against the machine belt, and start the machine.

When sufficient thread has been wound upon the bobbin, the bobbin winder will stop automatically.

If the thread does not wind evenly on the bobbin, loosen the screw (A) in the tension bracket and move the bracket to the right or left, as may be required, then tighten the screw.

The amount of thread wound on the bobbin is regulated by the screw (B). To wind more thread on the bobbin, turn the screw (B) inwardly. To wind less thread on the bobbin, turn this screw outwardly.

Bobbins can be wound while the machine is stitching.

To Replace the Bobbins and Thread the Bobbin Cases

The following instructions apply to both bobbin cases.

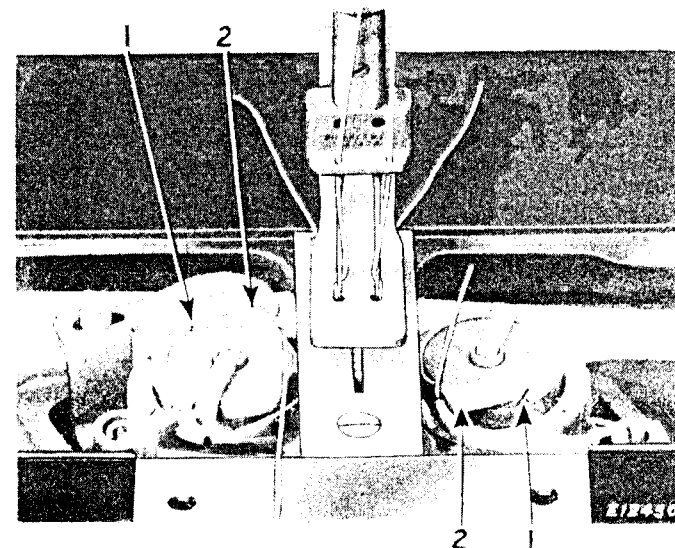

Fig. 9. Threading the Bobbin Cases

Hold the bobbin between the thumb and forefinger of the right hand, the thread drawing on the bottom from left to right, and place it on the center stud of the bobbin case, then push down the latch as shown in Fig. 9. Draw the thread into the slot (1) in the edge of the bobbin case and back of the projection (2) leaving a loose end of thread about two inches long above the slide. When closing the slides, leave just enough space for the threads to pass through.

Upper Threading

TO THREAD THE OUTSIDE NEEDLE OR THE ONE FARTHEST FROM THE UPRIGHT PART OF THE ARM, pass the thread from the left spool on the

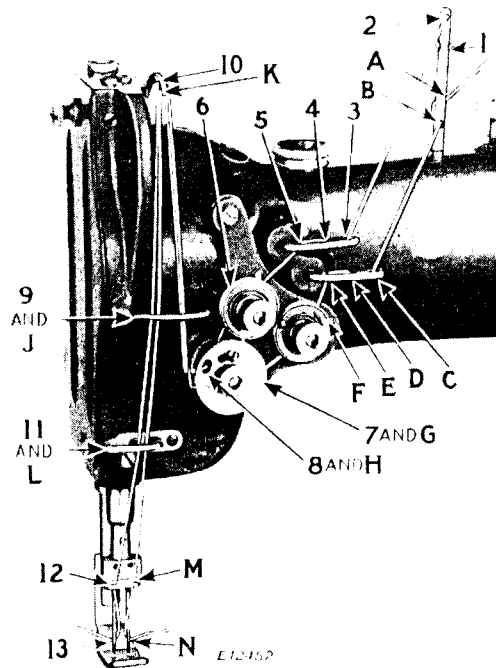

Fig. 10. Upper Threading

spool stand, through the left guide at the top of the spool stand, down and from right to left through the hole (1) in the pin on top of the machine, then from back to front through the hole (2) in the pin, down through the hole (3), up through the hole (4) and down through the hole (5) in the thread guide at the front of the machine, over from right to left between the left tension discs (6), down under from right to left around the thread controller (7), up into the fork (8) of the thread controller against the pressure of the wire controller spring, up through the thread guide (9), up and from right to left through the upper hole (10) in the end of the thread take-up lever, down through thread guide (9) again and through guide (11), down through the left hole (12) in the needle holder and from right to left through the eye of the left or outside needle (13).

TO THREAD THE INSIDE NEEDLE OR THE ONE NEAREST THE UPRIGHT PART OF THE ARM, pass the thread from the right spool on the spool stand, through the right guide at the top of the spool stand, down and from right to left through the hole (A) in the pin on top of the machine, then from back to front through the hole (B) in the pin, down through the hole (C), up through the hole (D) and down through the hole (E) in the thread guide at the front of the machine, under from right to left between the right tension discs (F), down under from right to left around the thread controller (G), up into the fork (H) of the thread controller against the pressure of the wire controller spring, up through the thread guide (J), up and from right to left through the lower hole (K) in the end of the thread take-up lever, down through the thread guide (J) again, down through guide (L), down through the right hole (M) in the needle holder and from left to right through the eye of the right or inside needle (N).

Draw about three inches of thread through the eye of each needle with which to commence sewing.

To Prepare for Sewing

With the left hand hold the ends of the needle threads, leaving them slack from the hand to the needles. Turn the

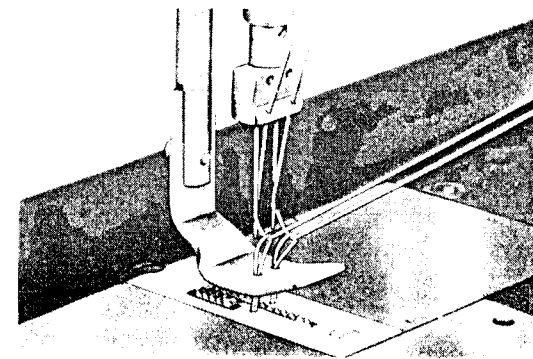
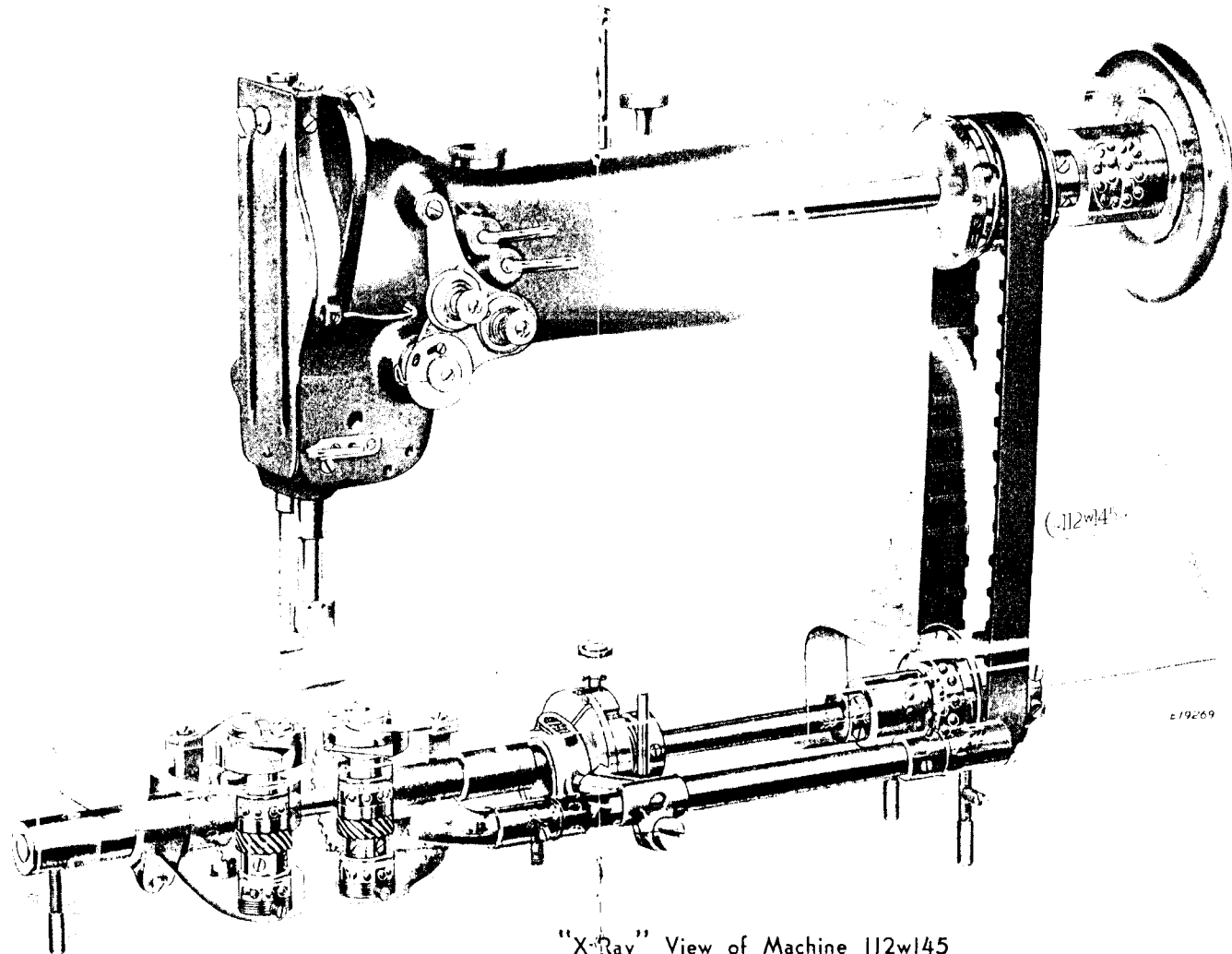

Fig. 11. Drawing Up the Bobbin Threads

machine pulley over toward you until the needles move down and up again to their highest point, thus catching the bobbin threads; draw up the needle threads and the bobbin threads will come up with them through the holes in the feed dog (see Fig. 11) Lay the threads back under the presser foot or roller presser and close the slides.



"X-Ray" View of Machine 112w145
Showing Ball Bearings and Simplified Feed Mechanism

To Commence Sewing

Place the material beneath the presser foot or roller presser lower the presser and commence to sew, turning the machine pulley over toward you.

To Remove the Work

Have the thread take-up lever at the highest point, raise the presser, draw the work back and cut the threads close to the goods. Lay the ends of the threads back under the presser foot or roller presser.

Tensions

The needle and bobbin threads should be locked in the center of the thickness of the material, thus:



Fig. 12. Perfect Stitch

If the tension on the needle thread is too tight, or if that on the bobbin thread is too loose, the needle thread will lie straight along the upper surface of the material, thus:



Fig. 13. Tight Needle Thread Tension

If the tension on the bobbin thread is too tight, or if that on the needle thread is too loose, the bobbin thread will lie straight along the under side of the material, thus:



Fig. 14. Loose Needle Thread Tension

To Regulate the Tensions

The tensions on the needle threads are regulated by the two thumb nuts (A2, Fig. 15) at the front of the tension discs on the front of the machine. To increase the tension, turn these thumb nuts over to the right. To decrease the tension, turn the thumb nuts over to the left.

The tensions on the bobbin threads are regulated by means of the screw nearest the center of the tension spring on the outside of each bobbin case. To increase the tension, turn the screw nearest the center of the tension spring over to the right. To decrease the tension, turn the screw over to the left.

To Regulate the Length of Stitch

The number of stitches per inch is stamped on the stitch indicating disc (D, Fig. 2) located on the arm shaft.

To change the length of stitch, press down the plunger (A, Fig. 2) in the bed of the machine and at the same time turn the machine pulley slowly until the plunger enters a notch in the adjustable feed eccentric cam. Still holding the plunger, turn the machine pulley over a part of a revolution until the number of the stitches per inch desired can be seen through the hole in the front of the arm at D, Fig. 2, then release the plunger (A).

To Regulate the Pressure on Material

The pressure on the material is regulated by the screw (B, Fig. 3) at the back of the machine, which acts on a flat spring. To increase the pressure, turn this screw downward. To decrease the pressure, turn this screw upward. The pressure should be only heavy enough to enable the feed to move the work along evenly.

INSTRUCTIONS FOR ADJUSTERS AND MECHANICS

Thread Controller

The function of the thread controller spring is to hold back the slack of the needle threads until the point of each needle reaches the goods in its descent, as without this controlling action of the spring, the slack thread or silk (more especially silk) will sometimes be penetrated by the point of the needle as the needle is descending.

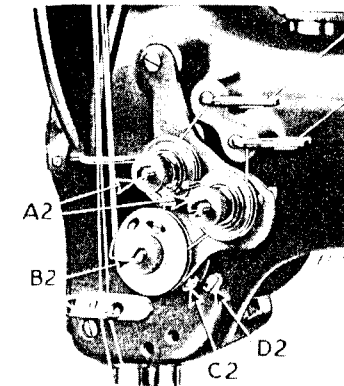

Fig. 15. Adjustment of Thread Controller

To change the thread controller stop for more controller action on the threads, loosen the set screw (C2, Fig. 15) and turn the thread controller spring stop to the right; for less action, turn the thread controller spring stop to the left, after which securely tighten the set screw (C2).

It may be found advisable to increase the tension of the spring for coarse thread, or to lessen it for fine thread.

To increase the tension of the thread controller on the threads, loosen the tension stud set screw (D2, Fig. 15), located nearly under the tension stud, and turn the tension stud (B2, Fig. 15) slightly to the left with a screw driver, or to decrease the tension, turn it to the right and retighten the stud set screw (D2).

To Set the Needle Bar

See that the needles are up in the holder as far as they will go. There are two lines across the needle bar about two inches above the lower end. When the needle bar is at its lowest position, the upper mark should be just visible at the end of the needle bar bushing.

In case the needle bar is not correctly set, loosen the needle bar connecting stud pinch screw (C, Fig. 4) and place the needle bar in the correct position as directed above, then retighten the screw (C).

TO SET A NEEDLE BAR WHICH HAS NO MARK. Set the feed eccentric so that there is no feeding motion, then set the needle bar so that when it rises .080 inch from its lowest position, and the points of the sewing hooks are at the centers of the needles, the eyes of the needles will be about 1/16 inch below the points of the hooks.

To Set the Sewing Hooks To or From the Needles

To prevent the points of the hooks from dividing the strands of the threads, they should run as close to the needles (within the scarf) as possible.

Turn the machine pulley over toward you until the points of the sewing hooks are at the centers of the needles. Loosen the four screws (P and Q, Fig. 16) underneath the bed of the machine and move the hook saddles to the right or left, as may be required, until the points of the hooks are as close to the needles as possible without striking them, then securely tighten the four screws (P and Q).

The function of the hook washer (needle guard) (AA, Fig. 18), which is attached to the bottom of the sewing hook, is to prevent the point of the hook from striking the needle if, when passing through the material, the needle is deflected toward the hook.

The needle guard can be bent with a small pair of pliers until it prevents the hook point from striking the needle, but it should not be bent outward enough to deflect the needle from its normal path.

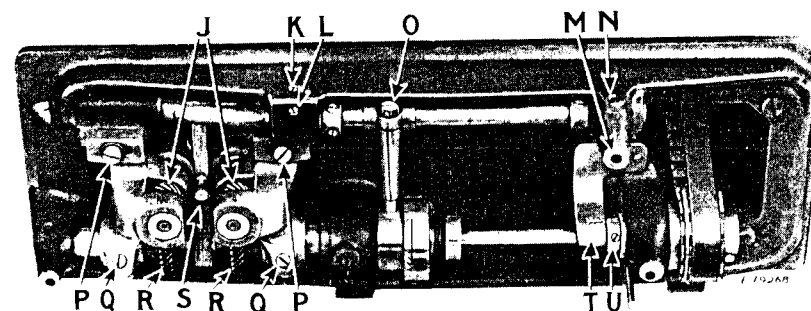

Fig. 16. Adjustments Underneath the Machine

To Time the Sewing Hooks

Remove the throat plate and turn the machine pulley over toward you until the lower mark across the needle bar is just visible at the end of the needle bar bushing on the upward stroke of the needle bar. If the needle bar and sewing hooks are correctly timed, the point of each hook will be at the center of its needle and about 1/16 inch above the eye.

In case the sewing hooks are not correctly timed, turn the machine pulley over toward you until the needle bar has descended to its lowest point and has risen until the lower timing mark across the needle bar is just visible at the end of the needle bar bushing. Loosen the two screws in the hub of each hook shaft gear (J, Fig. 16) and turn the hooks until the point of each hook is at the center of its needle. Then securely tighten the two set screws in each hook shaft gear (J).

To Adjust the Bobbin Case Opener

The bobbin case opener (V, Fig. 17) should be set so that it touches the bobbin case as lightly as possible, yet turns the bobbin case enough to make a sufficient opening for the free passage of the thread between the throat plate and the bobbin case.

To Remove the Bobbin Cases from the Sewing Hooks

Remove the four hook gib screws (W, Fig. 17) from the sewing hooks, lift off the hook gibs (Z, Fig. 18) and remove the bobbin cases (X, Fig. 17).

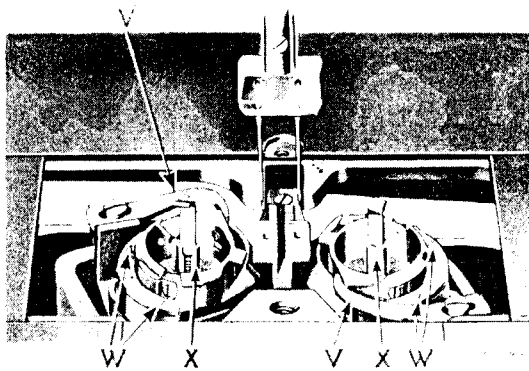

Fig. 17

To Remove the Sewing Hooks from the Machine

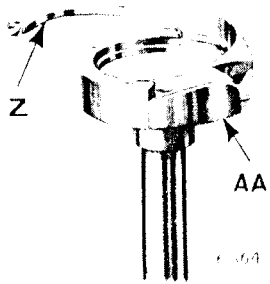

Fig. 18. Sewing Hook
Removed from Machine,
Showing Hook Washer

Remove the throat plate, feed dog, and the two bobbin case opening levers (V, Fig. 17). Then turn back the machine and loosen the four screws in the hubs of the hook shaft gears (J, Fig. 16) and place the end of a screwdriver against the shaft end of the hooks, tapping with the palm of the hand to drive out the sewing hooks.

To remove the ball bearing from the hook, rest the bearing on two pieces of sheet metal across the open jaws of a vise with the shaft end up, tap shaft until bearing is removed.

To Adjust the Feed Rock Shaft Bearings

The feed rock shaft is carried in split bushings which can be adjusted to take up any wear which may occur. Loosen the two lock screws (L and N, Fig. 16) and turn in the two adjusting screws (K and M) until all lost motion of the rock shaft has been eliminated, then securely tighten the lock screws (L and N).

To Raise or Lower the Feed Dog

Usually when the feed dog is at its highest position, it should show a full tooth above the throat plate.

Remove the throat plate; clean the lint and dust from between the feed points and replace the throat plate; tip the machine back and turn the machine pulley towards you until the feed dog is at its highest position; loosen screw (S, Fig. 16) in the feed lifting cam fork and raise or lower the feed dog, as may be required, then retighten the screw (S).

When raising or lowering the feed dog, be careful that its underside does not drop low enough to strike the sewing hooks.

The feed dog should be set so that it is centered in the slots in the throat plate when the feed eccentric is set for zero feeding movement. If it is not centered properly, loosen the pinch screw (O, Fig. 16) and adjust the feed dog as required, then securely tighten the pinch screw (O).

The Feed Eccentric

The feed eccentric is provided with a gib (B1, Fig. 19) which can be adjusted to take up any wear or loose motion between the feed eccentric and the eccentric body. To adjust the gib, loosen the two locking screws (C1, Fig. 19) nearest the gib, then turn in the two adjusting screws (D1) against the gib until all play is eliminated and the eccentric fits snugly in the slot in the eccentric body. Securely tighten the two locking screws (C1).

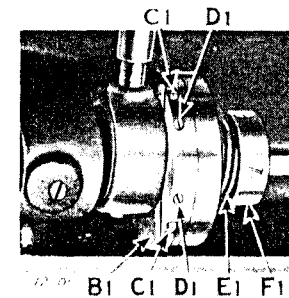

Fig. 19. The Feed Eccentric

The spring (E1, Fig. 19) presses against the feed eccentric cam to prevent it from moving out of position while the machine is operating. The collar (F1) may be moved to the right or left to change the spring pressure. It should ordinarily be set flush with the end of the hub of the eccentric body.

To Adjust the Stitch Length Indicator

Set the machine to produce eight measured stitches to the inch. Then loosen the set screw in the stitch indicating disc (D, Fig.2), press down the plunger (A, Fig.2) in the bed of the machine and at the same time turn the machine pulley slowly until the plunger enters the notch in the adjustable feed eccentric cam. With the machine in this position, the stitch indicating disc (D, Fig.2) should be set so that the figure "8" can be seen through the hole in the front of the arm, then tighten the set screw in the stitch indicating disc.

To Replace the Arm Shaft Connection Belt

Loosen the two set screws (at the right of the upper belt pulley in the arm) which fasten the inner race of the ball bearing to the arm shaft. After loosening these screws, remove the machine pulley, then remove the three screws in the flange of the ball bearing container adjacent to the machine pulley. The entire ball bearing assembly can then be removed from the machine. Remove the belt from the lower pulley, then lift the belt up through the arm cap hole as far as possible and draw it out through the space normally occupied by the ball bearing assembly.

Owing to the fact that the sewing hooks make two revolutions to one revolution of the hook shaft and that the feed eccentric is on the hook shaft, it is possible to have the sewing hooks correctly timed without having the feed eccentric correctly timed. To overcome this, the plate (T, Fig.16) is attached to the underside of the bed of the machine. This plate is marked with an arrow and the collar (U, Fig.16) on the hook shaft is also marked with an arrow.

After replacing the belt over the arm shaft, replace the arm shaft bearing and securely fasten it in position by the three screws in the flange, and the two set screws in the inner race; replace the machine pulley, place the belt on the upper pulley, and turn the machine pulley over toward you until the thread take-up lever is at its highest point. Then turn the hook shaft with the fingers until the arrow on the collar (U, Fig.16) is directly in line with the arrow on the plate (T). Now, without disturbing either the arm shaft or the hook shaft, slip the belt over the lower pulley. The feed will then be correctly timed with the needle bar.

CAUTION-DO NOT PINCH BELT in handling, as this will put a permanent kink in the wire reinforcements. Do not store near radiator or other hot place, preferably in a cool, dark place until belt is installed in machine.