

SINGER*
INDUSTRIAL PRODUCTS

107U202

Operator's Guide

Single Needle Lockstitch
Embroidery Machine

* A Trademark of THE SINGER COMPANY

LUBRICATION

Oil your machine. For best results, use SINGER "TYPE D" OIL. Apply a few drops of oil to all oiling points shown in Figs. 1 and 2.

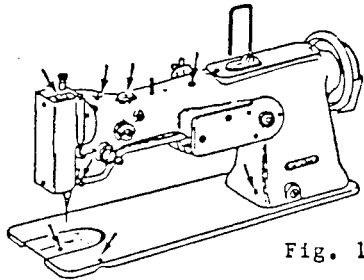

Fig. 1

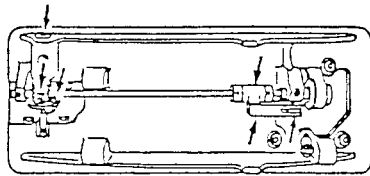

Fig. 2

When a machine is NEW or has been idle for several weeks, remove the face plate, swing open the arm top cover and oil the needle bar, take-up bearings and other parts which are in movable contact.

NOTE: 1. A machine in continuous use should be oiled frequently.
2. Apply a few drops of oil to the sewing hook each time the bobbin thread is replaced.

Introducing the Model 107U202 embroidery machine, the most dependable, top quality single needle lockstitch machine of its kind.

Quiet and smooth in operation, the 107U-202 was designed for your comfort, making sewing more pleasant, quicker and more profitable to you.

May we recommend that, before you begin to use your new embroidery machine, you discover the many advantages and ease of operation by going through this operator's guide.

SPEED

Maximum efficient speed is dependent upon the ability of the operator, the nature of operation and the type of thread and material being used.

The maximum speed recommended when stitching at 10mm bight or less is 2,000 SPM and 1,700 SPM when stitching at maximum bight of 12.7mm.

NOTE: 1. It is advisable to operate this machine at more moderate speeds at first until the parts which are in movable contact have become glazed by their action upon each other.

2. The machine pulley must always turn over toward the operator.

NEEDLE

Use Singer needles Catalog 1955-01 (or chrome finished 135x7, DPx7 needles). It is important that the needle be just right for the thread and material used and the work being done.

TO SET THE NEEDLE

Turn the machine pulley over toward you until the needle bar moves to its highest point.

After loosening the needle set screw, insert needle up into needle bar as far as it will go, with its long groove to the front of the machine, then tighten the needle set screw.

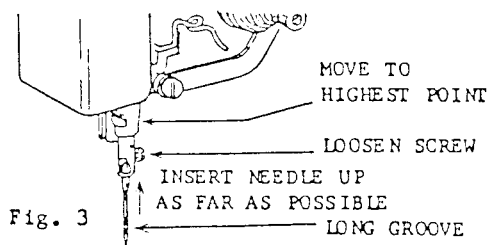

Fig. 3

TO REPLACE THE BOBBIN CASE

Turn machine pulley over toward you until the needle bar is at its highest point.



Fig. 11

Turn machine pulley over toward you until the needle bar is at its highest point. Take bobbin case by latch in left hand and place bobbin case on center stud of bobbin case holder and release latch. Press bobbin case back until latch catches

Press bobbin case back until latch catches groove near end of stud. Allow about 5 cm of thread to hang free.

TO REGULATE THE TENSION

The tension on the needle thread should be lighter than the bobbin thread so that the needle thread will lie on the bottom of the material as shown Fig. 12.



Fig. 12

Needle Thread

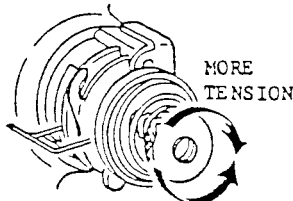

Fig. 13

Tension on the needle thread should be just enough to set the stitch properly in the material. To regulate the needle thread tension, turn thumb nut in front of the tension discs as instructed in Fig. 13.

Bobbin Thread

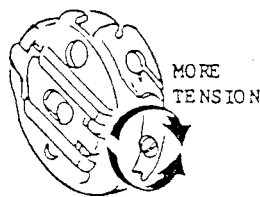

Fig. 14

Once the tension on the bobbin thread has been properly adjusted, a correct stitch can be obtained by varying the tension the needle thread only.

For average embroidery work, the tension on the bobbin thread should be very light.

To regulate the tension on the bobbin thread, remove bobbin case and turn the screw in the tension spring as instructed in Fig. 14 so that the bobbin thread will unwind by the weight of the bobbin case.

TO SET THE NEEDLE POSITION SELECTOR

Left, Center and Right needle positions can be obtained by setting the needle position selector lever on rear of machine to desired position.

To set the machine in left needle position, move selector lever to the right (looking at machine from front) and to set in right needle position, move selector lever to the left. (Fig. 15)

To set the selector lever (1) in desired setting, pull back knob (2), Fig. 16, and move selector lever (1) to either left or right until the selector lever pin clicks into the hole in the needle position plate.

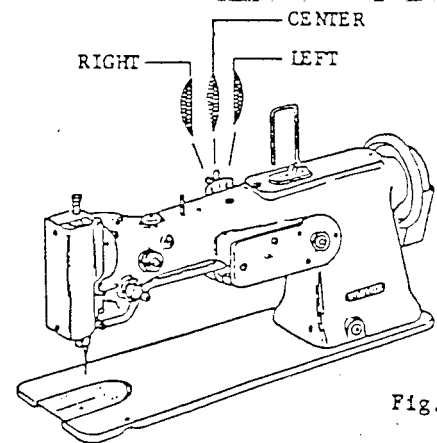

Fig. 15

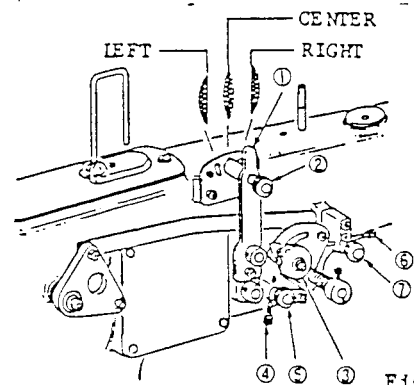

Fig. 16

TO REGULATE THE STITCH WIDTH

The width of zigzag stitch is controlled with the knee lever.

Stop screw is used to control the width of wider zigzag stitch and is locked in position with set screw (5) after setting to maximum width desired. (Fig. 16)

Stop screw (6) is used to control the narrower zigzag stitch and is locked in position with set screw (7) after setting to minimum width desired.

To set the machine for constant width zigzag stitch, tighten lock nut (3) shown in Fig. 16.

TO THREAD THE MACHINE

Turn machine pulley over toward you until the needle bar is at its highest point, then lead the thread from the thread stand through the threading points in the order shown in Fig. 4. Thread the needle from front to back through eye of needle. Draw about 5cm of thread through eye of the needle with which to start sewing.

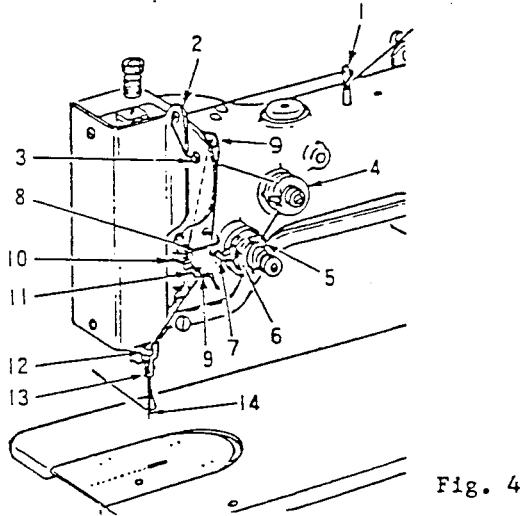

Fig. 4

TO REMOVE THE THROAT PLATE

Turn machine pulley over toward you until the needle bar is at its highest point, then reach under the bed of the machine and push throat plate upward as shown in Fig. 5 being careful not to touch the needle.

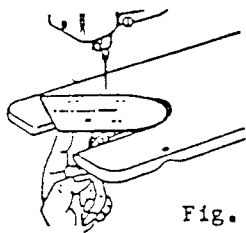

Fig. 5

TO REMOVE THE BOBBIN CASE

Turn machine pulley over toward you until the thread take-up lever is at its highest point. Remove throat plate. Reach under the bed of the machine with the left hand and remove the bobbin case as instructed in Fig. 6. To remove the bobbin case downward and the bobbin will drop out as shown in Fig. 7.

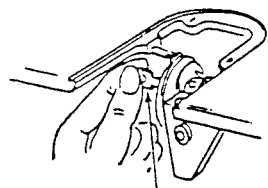

Fig. 6

OPEN LATCH

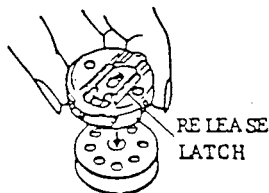

Fig. 7

BOBBIN DROPS OUT

NOTE: While the latch is kept open the bobbin will be retained in the bobbin case.

TO WIND THE BOBBIN

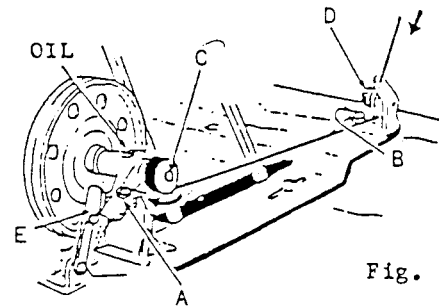

Fig. 8

Place bobbin on spindle (C), pushing it on as far as it will go and pass thread through threading points as shown in Fig. 8.

Wind end of thread around the bobbin a few times. Press down on thumb latch (E) and start machine.

The bobbin winder will stop automatically when the amount of thread for which it is regulated is wound upon the bobbin. For more thread on the bobbin, turn screw (A) clockwise; for less thread on the bobbin, turn screw (A) counterclockwise.

When winding a bobbin with fine thread, a light tension should be used. Adjust the knurled nut (D), Fig. 8, to regulate the tension.

If thread winds unevenly on bobbin, loosen screw (B) and move tension bracket to the left or right, as required. Tighten screw (B).

Bobbins can be wound while the machine is stitching.

NOTE: The amount of thread on the bobbin should be held to about 80% of its capacity and should be wound with light tension on the thread.

Oil your bobbin winder occasionally. Apply a few drops of oil to the oil hole in bobbin winder as shown in Fig. 8.

TO THREAD THE BOBBIN CASE

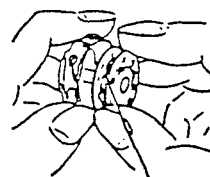

Fig. 9

Hold bobbin case as shown in Fig. 9 and place bobbin into bobbin case so that the thread will unwind in the direction shown in Fig. 9.

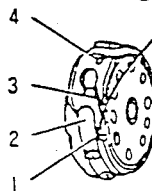

Fig. 10

Pull thread into slot 1 and under the tension spring 2. Then pull thread into slot 3 and draw it out from delivery eye 4. (Fig. 10)

TO INSTALL THE KNEE LIFTER ROCK SHAFT COMPLETE

Fasten knee lifter rock shaft complete to underside of table as shown in Fig. 17.

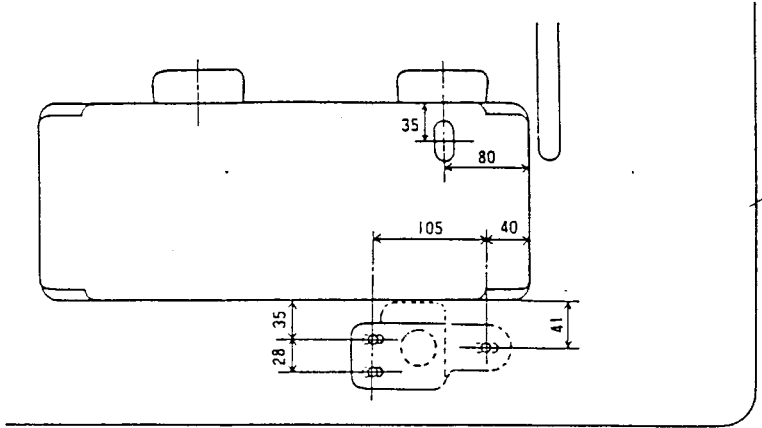

Fig. 17

Setting of knee lifter rod

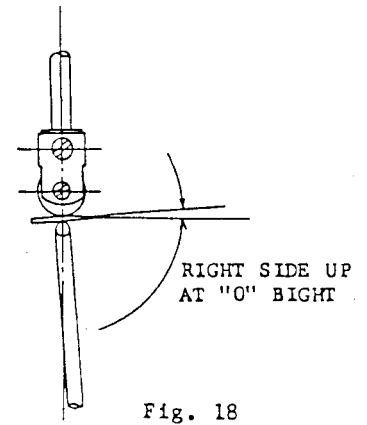

Fig. 18

Set bight to "0" and adjust knee lifter lever rod so that its plate portion will be tilted with the right side up as shown in Fig. 18.

NOTE: When making the above adjustment, every care should be taken to keep the roller in contact with the plate on the knee lifter lever rod.

SPECIFICATION

Machine	107U202
Stitch type	Lockstitch zigzag
Stitch width (mm)	0 - 12.7
Stitch width adjustment	Stitch width controlled by stop screws
Needle positions	Left, Center and Right
Speed (SPM)	Up to 10mm stitch width 2,000 Over 10mm and up to 12.7mm stitch width 1,700
Thread take-up lever	Sleeve type
Sewing hook	107 (DP) for embroidering
Attachment	Compass (attachment for cording available at additional charge)
Clearance at right of needle	260mm
Others	Provision made for presser mechanism. No feed mechanism. Throat plate with screws holes provided at 3mm interval for attaching the compass.