

SINGER
155B8BV

SINGER^{*}

OPERATOR'S GUIDE

MODEL 155B8BV

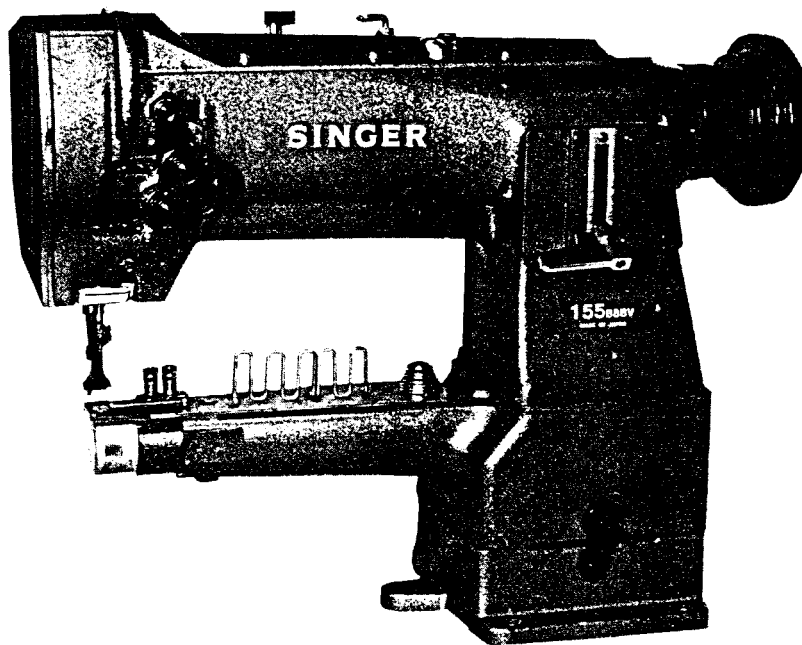

INSTRUCTIONS FOR USE OF SINGER MODEL 155B INDUSTRIAL SEWING MACHINES

SINGER 155B is a single needle, lock-stitching, compound feed & walking foot, semi-automatic lubrication system, narrow (46 ϕ) cylinder bed sewing machine.

Please read this guide thoroughly to insure the best performance.

SPECIFICATIONS

MAXIMUM SPEED: 3,000 s.p.m.

NEEDLE: CAT. NO. 3355, #11—#23 Standard Needle #16

NEEDLE POSITION: 9 mm (available 7 mm on order) from the left end of cylinder bed . . .

NEEDLE BAR STROKE: 33.2 mm

HOOK & BOBBIN: Rotating hook, 22 ϕ x 8.9 mm

STITCH LENGTH: Maximum 5 mm

FEED MECHANISM: Drop and Needle feed, and walking foot. With reverse stitch.

PRESSER FOOT: Alternating pressers

PRESSER BAR STROKE: 7 mm (by hand), 10 mm (by knee lifter)

THREAD TAKE UP: Slide motion type

DIAMETER OF CYLINDER BED: 46 ϕ

LUBRICATION: Semi-automatic lubrication

LUBRICATION OIL: White spindle oil

WORKING SPACE: 258 mm x 110 mm

WEIGHT: 29 KGS. (with BASE)

MOTOR: 1/3 HP or 1/2 HP Clutch motor. 2P

THREAD: Synthetic #50—#8

USE: All kinds of work in the clothing, footwear, upholstery, leather industry such as shoe, canvas products, dress shields, sleeve, sandals, gloves, sports goods, is suitable for various kinds of tape stitching with a edge binder which is interchangeable without having any alteration to any other parts.

SPARE PARTS LIST
(for one year)

Model 155B8BV

<u>PARTS NO.</u>	<u>NAME</u>	<u>Q'TY</u>
X 17033	Rotating hook complete	1 pc. /
X 17086	Vibrating presser foot	1 pc. /
X 17083	Lifting presser foot	1 pc. /
X 17089	Needle plate	1 pc. /
X 17073	Feed dog	1 pc. /
	Needle	100 pcs. /
X 10535	Needle set screw	3 pcs. ✓
S 15089	Needle bar thread guide	1 pc.
X 10760	Felt for thread guide	3 pcs. ✓
X 10689	Thread controller spring	3 pcs. ✓
Total:		115 pcs.

75 made (85)

SPARE PARTS LIST
(for two years)

Model 155B8BV

<u>PARTS NO.</u>	<u>NAME</u>	<u>Q'TY</u>
17033	Rotating hook complete	3 pcs.
17086	Vibrating presser foot	3 pcs.
17083	Lifting presser foot	3 pcs.
17089	Needle plate	3 pcs.
17073	Feed dog	3 pcs.
	Needle: #400	200 pcs.
10535	Needle set screw	6 pcs.
15089	Needle bar thread guide	3 pcs.
10760	Felt for thread guide	6 pcs.
10689	Thread controller spring	6 pcs.
Total:		236 pcs.

— INDEX —

CONTENTS

	Page
Setting up the machine	2
Oiling	2 - 3
Oil adjustment	3
Needle	4
Thread	4
Winding bobbin	5
Adjustment of the bobbin winder	5
Inserting and removing the bobbin	6
Threading the machine	7
Regulating the thread tension	7
Regulating the pressure on goods	8
Adjusting the stitch length and reverse stitch	9
Adjusting the lift of the alternating presser feet	9
Instructions for synchronized binder taping	10

INFORMATION FOR ADJUSTMENT

Adjusting the timing of the needle plate, needle and feeder	11	12
Adjusting the height of the needle bar	12	
Timing between the needle and the hook	13	
Timing between the needle and the feeder	14	
Adjusting the height of the presser feet	14	15
Timing of the vibrating presser foot	15	
Adjusting the thread controller spring	16	

2

SETTING UP THE MACHINE (Fig. 1)

* Before setting up the machine on the table, attach the relative parts to the table.

- | | | |
|------------------|--------------------|------------------|
| (1) Stand | (2) Motor | (3) Treadle |
| (4) Cotton stand | (5) Tape stand | (6) Machine head |
| (7) Knee lifter | and Machine base | (8) Chain |
| (9) V shape belt | (10) Bobbin winder | |

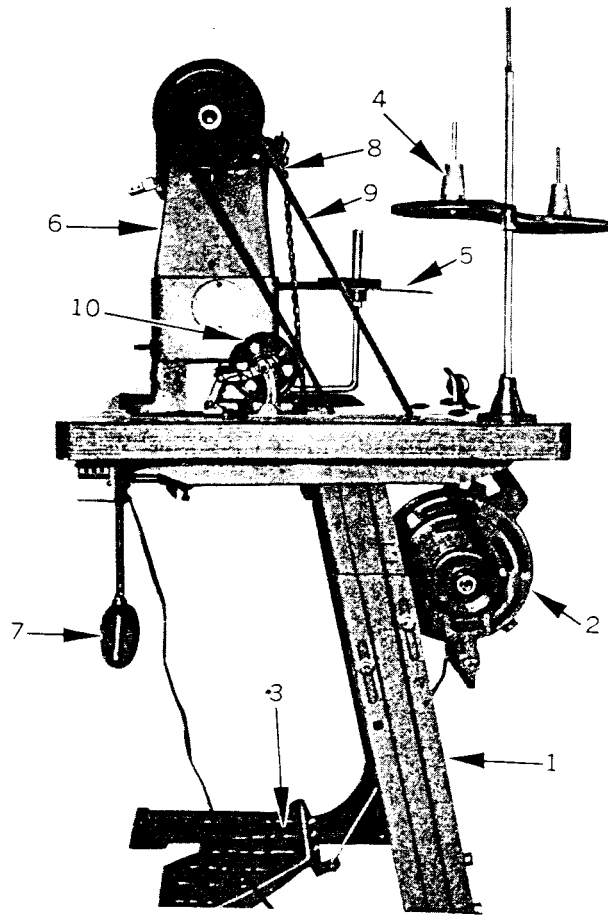

Fig. 1

OILING AND ITS ADJUSTMENT (Fig. 2)

* Do not operate the machine, even if for testing, unless it has been properly oiled.

To fill the oil reservoir on the top of the machine, pour oil through the oil filler hole (A), until oil level reaches to the upper reference line (B).

* Oiling is automatically made by the vibration of the machine while sewing, operating through the oiling wicks in the machine. Oil flow stops automatically when the operation of the machine ends.

* When starting the machine initially and after not being used for long periods of time check the oil volume through oil level indicator (B), and oil necessary parts before starting.

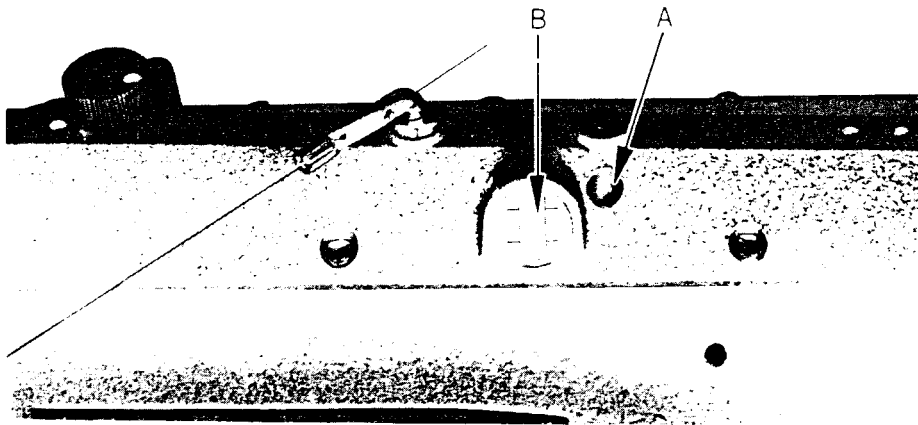
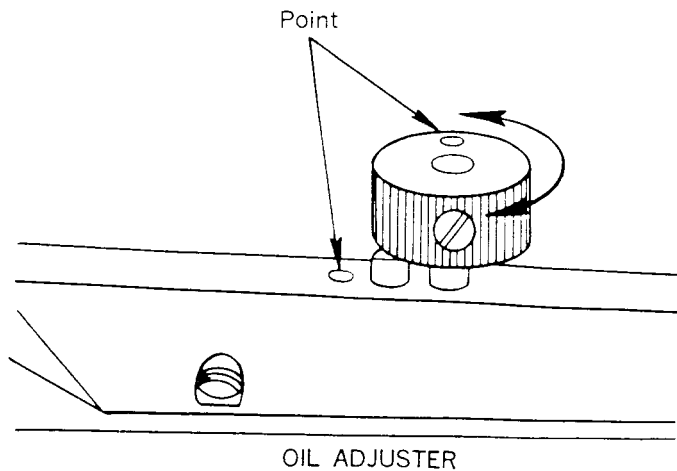

Fig. 2

OIL ADJUSTMENT

• While operating the machine, the lubrications to each spot of the machine are made.

When the machine is in continuous operation you may stop the oil flow by turning the dial until the two points come together as shown in the illustration below.



4

NEEDLE (Fig.3)

* The size of the needle to be used should be determined by the size of the thread, which must pass freely through the eye of the needle.

HOW TO ATTACH THE NEEDLE

1. Turn the machine pulley over toward you until the needle bar (1) moves up to it's highest point.
2. Loosen the needle set screw (2) and put the needle (3) up into the needle bar as deeply as it will go, so that the long groove of the needle faces left.
3. Tighten the needle set screw securely.

THREAD

- * Cotton, synthetic or silk thread can be used in thickness up to # 8.
- * Always use left twisted thread for upper thread, but you can use either right or left twisted thread for lower thread.

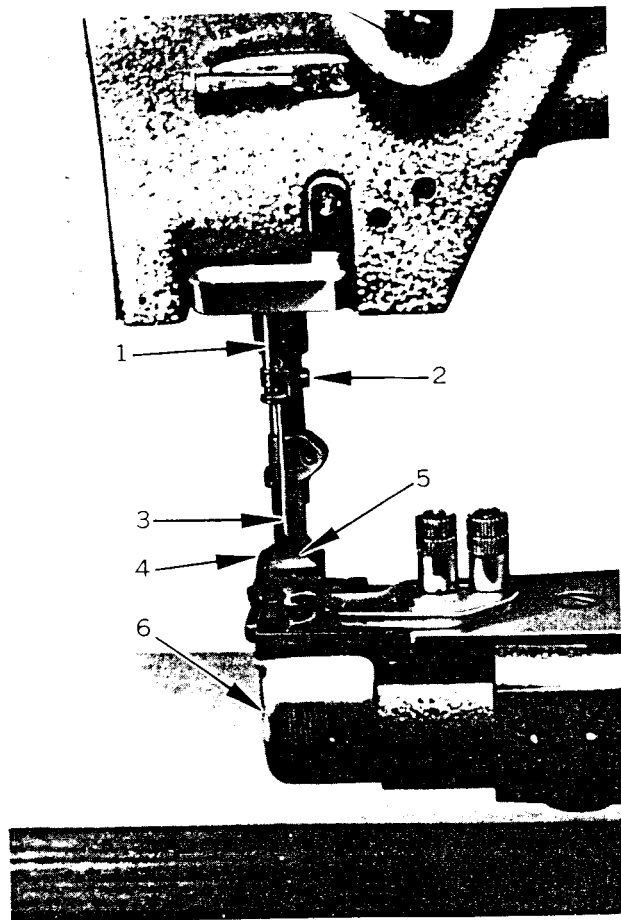

Fig. 3

WINDING THE LOWER THREAD ON THE BOBBIN (Fig. 4)

1. Push a bobbin on the bobbin winder spindle (1) as far as it will go.
2. Pass the thread from the thread stand downward through the eye (6) in the tension bracket, then between and around the back of the tension disc.
3. Bring the thread forward toward the bobbin and wind from below in clock-wise direction several times around the bobbin.
4. Push the lever (3) so that the pulley (2) and V belt (9, Fig. 1) will engage and then start the machine.
5. The pulley (2) will automatically be free from the belt and stopped after the bobbin is filled with thread.

THE ABOVE OPERATION CAN BE DONE WHILE SEWING.

ADJUSTMENT OF THE BOBBIN WINDER (Fig. 4)* **IN CASE OF UNEVEN WINDING**

If the thread does not wind evenly on the bobbin, loosen the screw (4) in the tension bracket and move the bracket to the right or left as may be required, then tighten the screw.

* **WINDING AMOUNT OF THREAD**

Adjustment screw (5) can be turned in or out to increase or decrease the amount of thread wound on the bobbin.

* **WINDING STRENGTH**

Strength of the winding can be adjusted with nut (6).

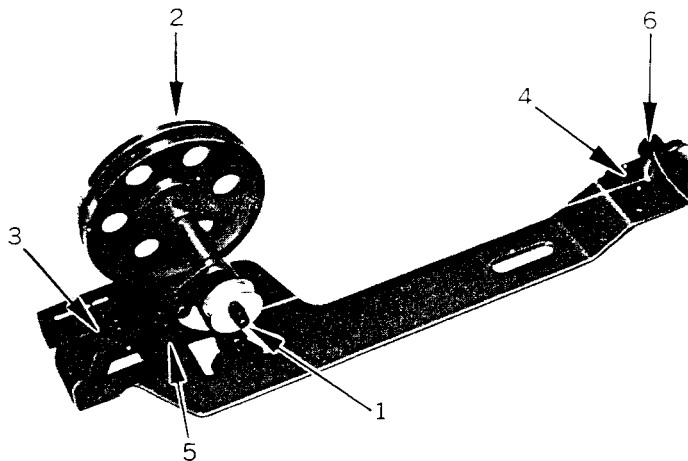

Fig. 4

6

INSERTING AND REMOVING BOBBIN (Fig. 5 and 6)

1. Raise the needle bar to its highest point. Draw out the end cover (6, Fig. 3)
2. Pull up the latch (1, Fig. 5) and draw out the bobbin from the bobbin case.
3. To insert a full bobbin (Fig. 6), hold it pulling out the end of thread by about 5 cm, and insert the bobbin into the bobbin case.
4. Lead the end of thread out through the slot of the bobbin case, and under the tension spring (1, Fig. 6) and then the thread guide.
* THREAD WINDING DIRECTION when fitting the bobbin into the bobbin case. Check the thread winding direction as shown Fig. No. 6.
5. Draw out about 5 cm of thread, pull up the latch (1, Fig. 5) keep the slot of the bobbin case facing up and fit the bobbin case into the hook as deeply as it will go. Push down the latch securely.
6. Close the end cover, but leave sufficient space for passage of the thread.

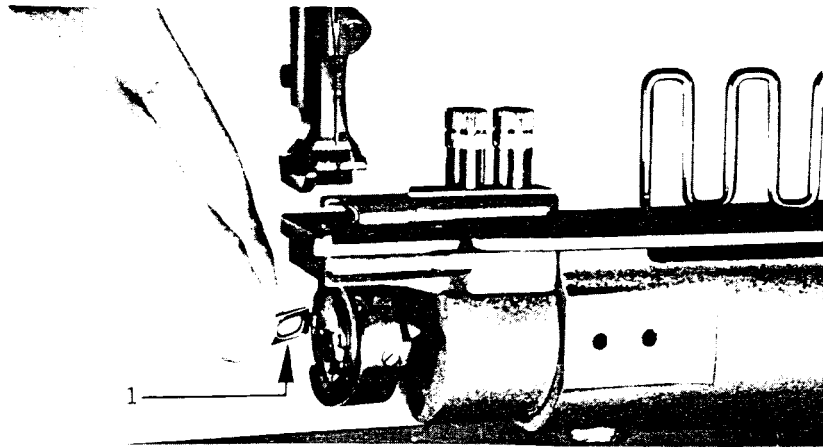

Fig. 5

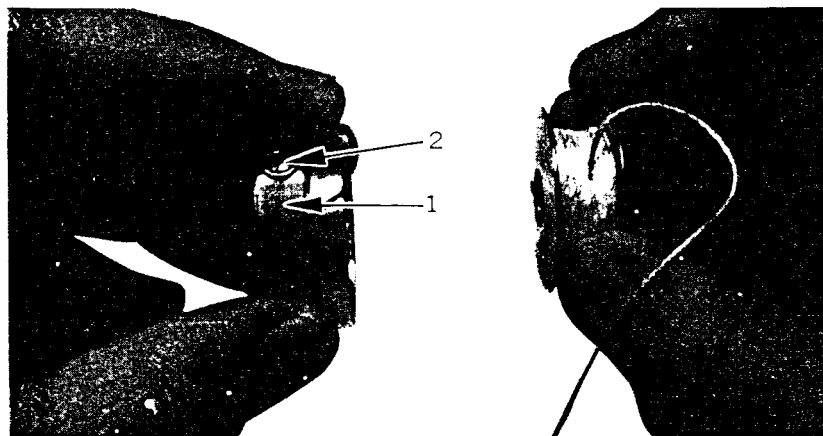

Fig. 6

THREADING THE MACHINE (Fig. 7)

1. Raise the needle bar to its highest point and lead the thread from the thread stand in the following manner.

From the thread stand, lead the thread to the thread guide (1) on the top of the machine arm, down to the upper guide hole of the thread guide (2) from right to left. Pass the thread in weaving fashion through the other two holes in (2) and from right to left over and between the tension discs (3). Now pull the thread downward from right to left beneath and around thread controller (4), continue to pull the thread upward through the fork in the thread controller and against the check spring (5) and through the thread guide (6), pull the thread upward through the eye in the take-up lever (7) down through the thread guide (6) again and then through the thread guide (8), (9) and (10), and from left to right through the eye of the needle.

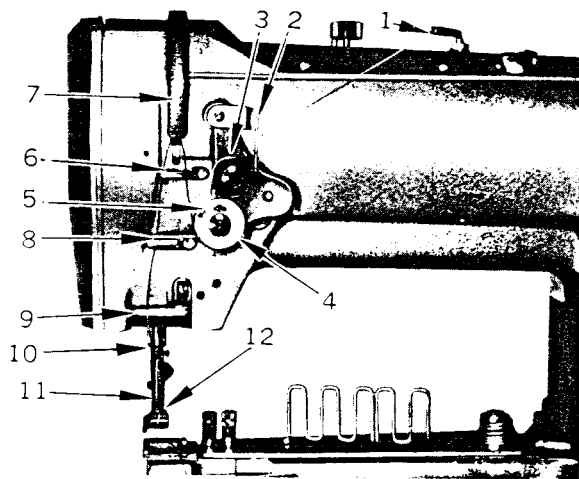

Fig. 7

2. After the above threading, hold the end of thread with your left hand, and turn the pulley with your right hand so that bobbin thread may be picked up by needle thread. And pull the ends of thread on the other side bed through and under the presser foot.

REGULATING THE THREAD TENSIONS

* For ordinary stitching, the tension of the upper and lower threads should be equal so as to lock both threads in the center of the fabric. If the tension on either thread is stronger than on the other, imperfect stitching will be the result.

* If the tension on the upper thread is stronger than that on the lower thread, it will be straight along the upper surface of the fabric.

* If the tension on the lower thread is stronger than that on the upper thread, the lower thread will lie straight along the underside of the fabric.

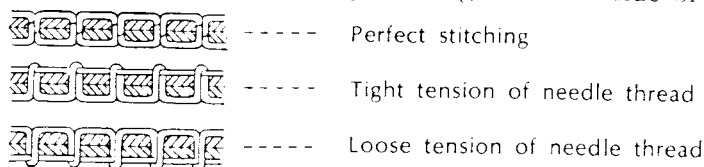
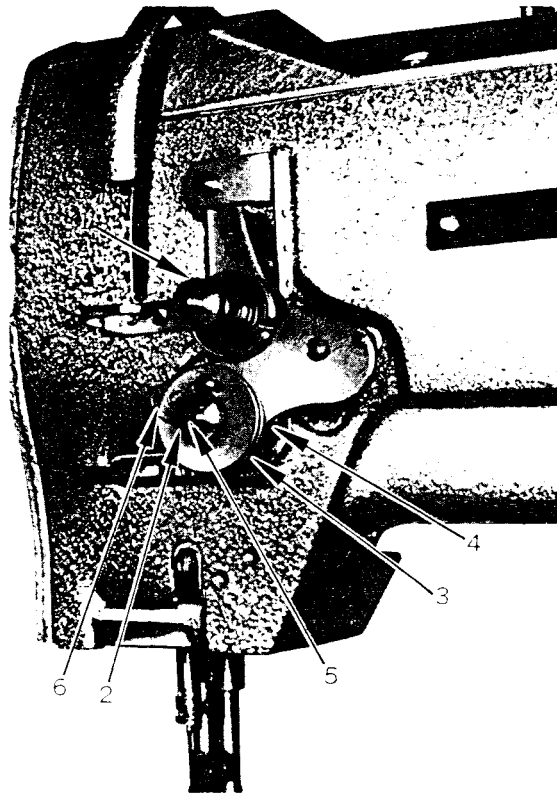

Fig. 8

8

HOW TO REGULATE THE THREAD TENSION (Fig. 9)



1. TENSION OF THE UPPER THREAD

To adjust the tension of the upper (needle) thread, turn the serrated nut (1) to the right for increasing tension. If you desire to decrease it, turn the nut to the left.

2. TENSION OF THE BOBBIN THREAD

To increase the tension, turn the screw (2, Fig. 6) to the right, and to decrease it, turn the screw to the left with a screw driver.

Fig. 9

ADJUSTMENT OF THE PRESSURE ON GOODS (Fig. 10)

The pressure of the presser feet is regulated by the adjusting screw (1).

- * To increase the pressure, turn the screw to the right.
- * To decrease it, turn the screw to the left.

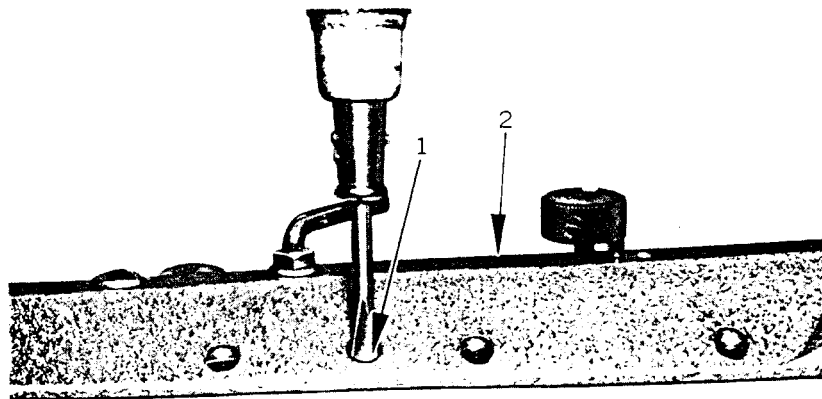

Fig. 10

ADJUSTING THE STITCH LENGTH (Fig. 11)

Stitch length is adjusted by turning the serrated nut (11) so that the reference mark on the collar (3) comes in line with the desired stitch length reference line on the plate (2).

- * If you desire to decrease the stitch length, turn the serrated nut to the right.
- * When you desire reverse stitch, push the lever (4) up as far as it will go.

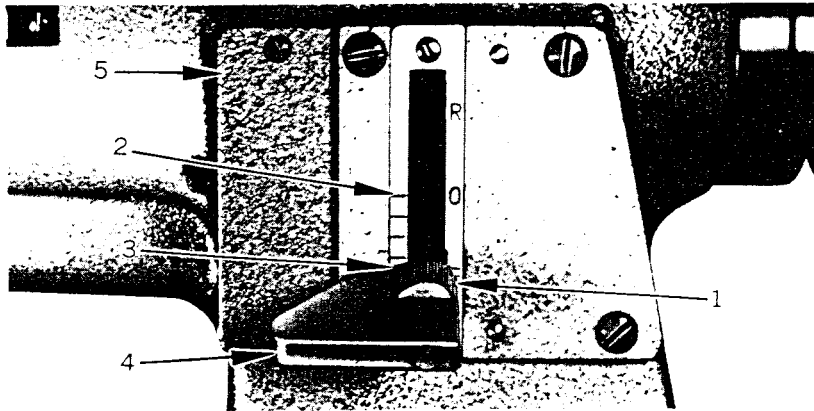

Fig. 11

ADJUSTING THE LIFT OF THE ALTERNATING PRESSER FEET (Fig. 12)

The thickness of the material sewn should control the height of the lift of the alternating presser feet.

It should normally be just high enough for clearance of the material. With normal adjustment both feet lift to equal height.

- * To adjust the lift, loosen the wing nut (1), move up the nut to raise the lift, and push down this nut to lower the lift.
- * When altering the lift of the lifting presser foot (4, Fig. 3) unequally against that of the vibrating presser foot (5, Fig. 3) or vice versa, see the instructions "ADJUSTING THE HEIGHT OF THE PRESSER FEET".

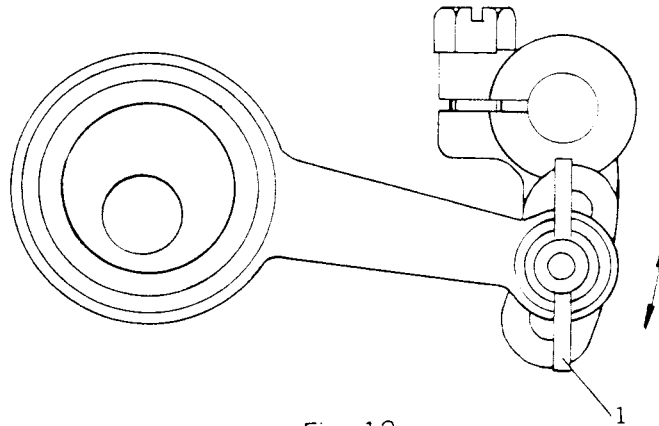

Fig. 12

10

INSTRUCTIONS FOR SYNCHRONIZED BINDER TAPING (Fig. 13)

HOW TO SET THE TAPE

1. Lift the two serrated nuts (1) slightly and open the plate (2) toward you.
 2. Pass the tape (3) alternately as indicated in the Fig. 28 through the tape guide (4).
 3. Cut obliquely the edge of the tape and pass it through the binder (5) and draw it out about 2 cm.
- * If the tape has a right and wrong side, pass tape the wrong side up.
4. Close the plate (2).

ADJUSTING THE BINDER (Fig. 13)

The setting position of the binder depends on the shape of the binder, tape width and thickness of goods.

Accordingly, it is determined through actual sewing test.

- * To adjust this, loosen the nuts (1), move the binder to the right or left to get proper position. Then, tighten the nuts.
- * AVAILABLE various kinds of binder

Binders, two-fold, three-fold and four-fold, are interchangeable without alteration to any other parts. Any kind of binder will be available on order.

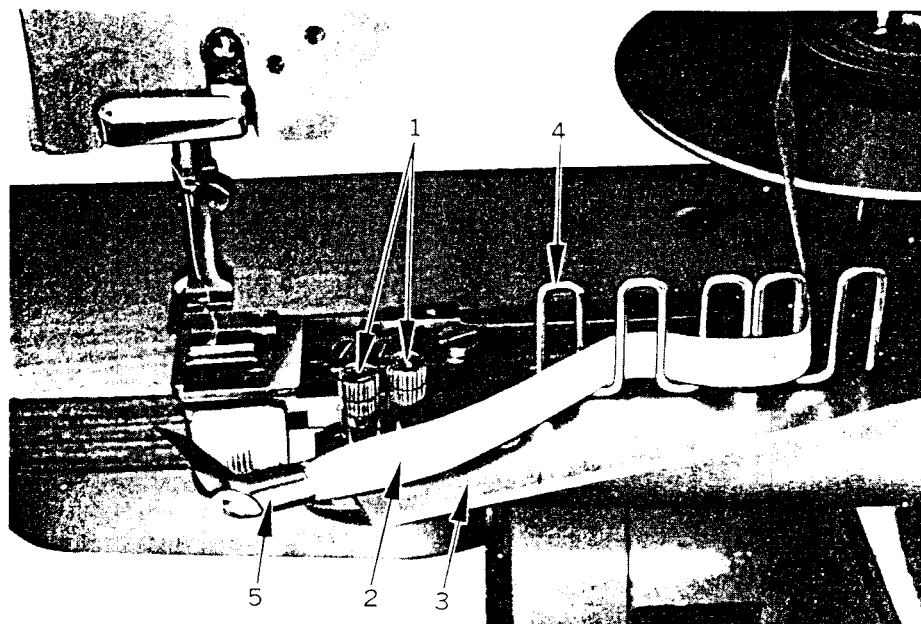

Fig. 13

ADJUSTING THE TIMING OF THE NEEDLE PLATE, NEEDLE AND FEEDER**1) RELATIVE POSITION OF THE FEEDER TO NEEDLE PLATE**

1. Lay down the machine and check that the screw (2, Fig. 16) is securely tightened on the V ditch (1, Fig. 16).
2. Adjust the feed motion to the maximum and loosen the screw (2, Fig. 19) with a hexagon wrench (standard accessories).
3. Set the position of the feeder so that both clearances between feeder and needle plate are equal before starting feed motion and after finishing the feed.
4. Securely tighten the screw (2, Fig. 19)

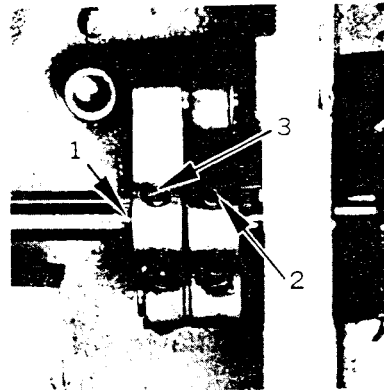

Fig. 16

12

2) THE POSITION OF THE NEEDLE AND NEEDLE HOLE OF THE FEEDER

- * To adjust this, turn the hand wheel to raise the needle bar to its highest point and put in a perfect needle.
- * Turning the hand wheel to lower the needle bar, slowly, check whether the needle descends to the center of the needle hole of the feeder or not.
- * If the needle does not enter into the center of the hole,
 1. Lay down the machine and check whether the screw (3, Fig. 14, Fig. 16) is securely tightened on the V ditch (1, Fig. 16).
 2. Remove the cover (5, Fig. 11)
 3. Loosen the screw (1, Fig. 17)
 4. Holding the bottom of the needle bar rock frame (1, Fig. 18), move it as may be required to get the correct position to the feeder.
 5. Tighten the screw and close the cover.

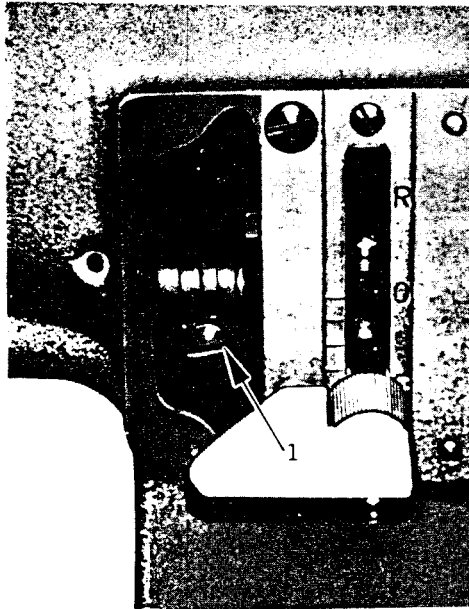

Fig. 17

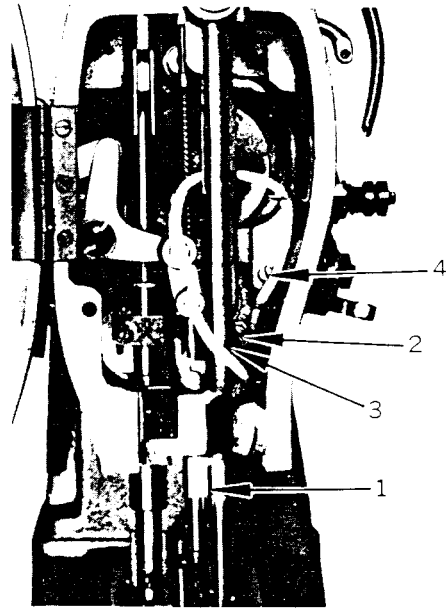

Fig. 18

ADJUSTING THE HEIGHT OF THE NEEDLE BAR

- * When the needle bar is at its lowest point, normally the measurement between the surface of the needle plate and the upper end of the needle eye is 12.6 mm.
- * To adjust this,
 1. Loosen the screw (2, Fig. 18)
 2. Move the setting position of the needle bar and needle bar connecting stud (3, Fig. 18) to get the correct position.
 3. Tighten the screw.

NOTE: These measurements are approximate standard, accordingly, following final adjustments, TIMING BETWEEN THE HOOK AND THE NEEDLE, are recommended.

TIMING BETWEEN THE HOOK AND THE NEEDLE

- After setting the needle bar height, confirm as follows:

Set the stitch length to 0, turn the hand wheel to lower the needle bar to its lowest point, turn the hand wheel toward you.

When the needle raises 2 mm from the lowest point of its travel, normally the hook point comes at the center line of the needle and the measurement between the hook point and the upper end of the needle eye should be 2 mm, furthermore the clearance between the hook point and the needle hollow should be about 0.05 to 0.1 mm.

- TIMING AND THE CLEARANCE ADJUSTMENT (Fig. 19)

1. Loosen the two screws (1).
2. Adjust the timing to conform to that shown in Fig. 20.
3. Also adjust the clearance by moving the hook to the right or to the left as required.
4. After adjustment, securely tighten the screws.

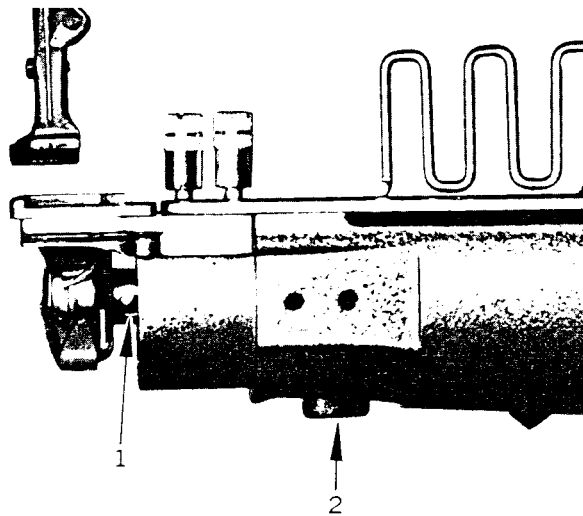

Fig. 19

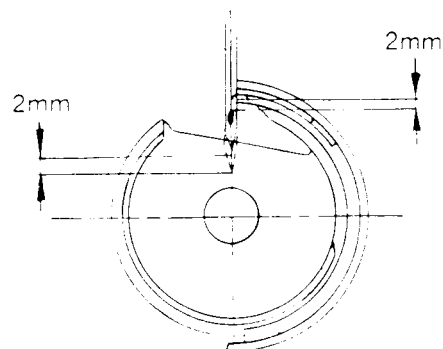

Fig. 20

14

TIMING BETWEEN NEEDLE AND FEEDER

* While the feeder feeds the material, the needle also moves together with the feeder and feeds the material.

* To adjust this,

1. Remove the top cover (2, Fig. 10)
2. Loosen the screws (1, Fig. 21) and move the cam (2, Fig. 21)

HOW TO ADJUST

1. Turn the hand wheel toward you to the point where the needle and the hook point cross.
2. Pushing the stitch length regulating lever (4, Fig. 11) up and down, turn the cam (2, Fig. 21) and set at the point both the needle and the feeder rest.
3. Tighten the screws securely and close the top cover.

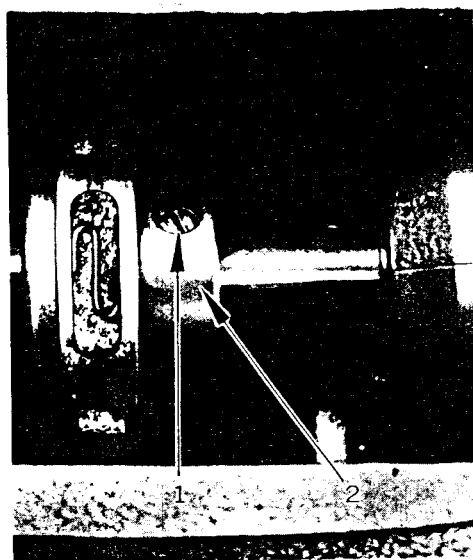

Fig. 21 LSC-8BV

ADJUSTING THE HEIGHT OF THE PRESSER FEET

* ADJUSTMENT OF THE PRESSER BAR LIFTER

1. Loosen the screw (1, Fig. 10) sufficiently.
2. Raise the presser bar lifter and loosen the set screw (1, Fig. 22).
3. Move the lifting presser foot (4, Fig. 3) up or down as may be required so as to get the correct height.
4. Tighten the screws securely.

* ADJUSTING THE LIFT OF ALTERNATING PRESSER FEET

If the height of the lifting presser foot changes, the momentums of the lifting and vibrating presser foot vary, thus the height of the vibrating presser foot must be adjusted.

HOW TO ADJUST:

1. Lower the presser bar lifter, holding the vibrating presser foot (5. Fig. 3)
2. Loosen the hexagon screw (2. Fig. 22) and move the presser foot up or down as may be required.
3. After setting the position, tighten the screw.

TIMING OF THE VIBRATING PRESSER FOOT

* Turn the hand wheel toward you, after lowering the presser bar lifter, the vibrating presser foot should reach the feeder earlier than the needle eye, and when the needle raises, the vibrating presser foot should leave the feeder after the needle eye has left the feeder.

The vibrating presser foot must tightly hold the goods while the needle is passing the goods to avoid irregular stitches.

* To adjust this,

1. Set the lift of the alternating presser feet so that they are equal.
2. Loosen the two screws (3. Fig. 22) and adjust the rotating position of the cam (4. Fig. 22) faster or slower as may be desired.
3. Tighten the screws.

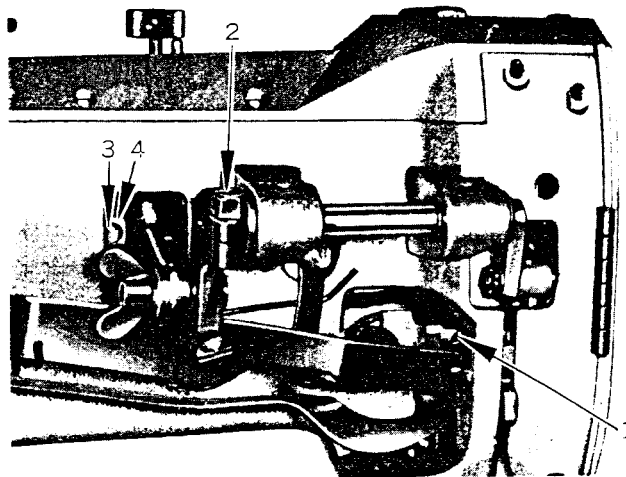

Fig. 22

16

ADJUSTING THE THREAD CONTROLLER SPRING

* Normally, the thread controller spring (2, Fig. 9) should take up the slack of the upper thread until the needle reaches the goods, and it should pause while the needle raises and the upper thread passes through the bobbin case.

* For more controlling action on the thread

1. Loosen the stop screw (3, Fig. 9)
2. Move the stop (4, Fig. 9) to the right. (For less action, move it to the left)
3. Tighten the screw.

* HOW TO ADJUST THE TENSION OF THE SPRING

1. Loosen the serrated nut (5, Fig. 9) slightly.
2. Loosen the screw (4, Fig. 18) slightly.
3. Turn the tension stud (6, Fig. 9) slightly to the left to strengthen the tension (to lighten the tension, turn to the right) with a screw driver.
4. Tighten the screw and the nut.