

SINGER

147-80,147-81,147-82,147-84,147-85

AND 147-86

USE ONLY **SINGER*** OILS and LUBRICANTS

*They insure freedom from lubricating trouble and
give longer life to sewing equipment*

The following are the correct lubricants for this machine:

TYPE B — MANUFACTURING MACHINE OIL, HEAVY
GRADE

When a stainless oil is desired, use:

TYPE D — MANUFACTURING MACHINE OIL, STAIN-
LESS, HEAVY GRADE

OTHER **SINGER** LUBRICANTS

TYPE E — STAINLESS THREAD LUBRICANT

For lubricating the needle thread of sewing machines for stitching fabrics or leather where a stainless thread lubricant is required.

TYPE F — MOTOR OIL

For oil lubricated motors and plain bearings in power tables and transmitters.

NOTE: All of the above oils are available in 1 quart, 1 gallon and 5 gallon cans or in 55 gallon drums.

GEAR LUBRICANT

This specially prepared grease is recommended for gear lubrication on manufacturing sewing machines.

BALL BEARING LUBRICANT

This pure grease is specially designed for the lubrication of ball bearings and ball thrust bearings of motors and electric transmitters, ball bearing hangers of power tables, etc. **Furnished in 1 lb. and 4 lb. tins.**

Copyright, U. S. A., 1923, 1931, 1936, 1940, 1941 and 1946
by The Singer Manufacturing Company
All Rights Reserved for all Countries

18987

INSTRUCTIONS

FOR USING AND ADJUSTING

SINGER* SEWING MACHINES

147-80, 147-81, 147-82, 147-84,
147-85 AND 147-86

ONE NEEDLE AND ONE LOOPER
TWO-THREAD CHAIN STITCH

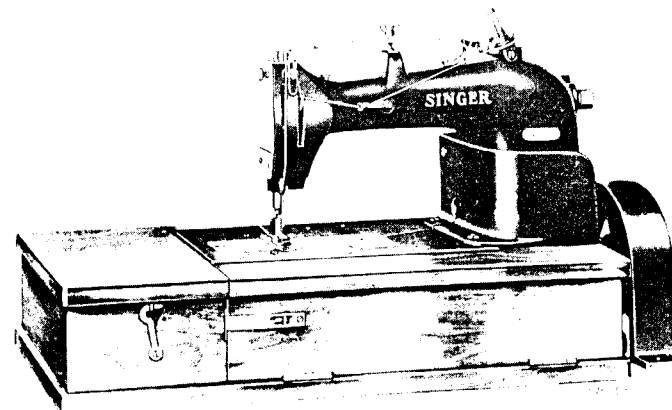

MACHINE 147-80

* A TRADE-MARK OF

THE SINGER MANUFACTURING CO.

TO ALL WHOM IT MAY CONCERN:

The improper placing or renewal of the Trade-Mark "SINGER" or any other of the Trade-Marks of The Singer Manufacturing Company (all of which are duly Registered Trade-Marks) on any machine that has been repaired, rebuilt, reconditioned, or altered in any way whatsoever outside a SINGER factory or an authorized SINGER agency is forbidden.

THE IMPORTANCE OF USING **SINGER*** PARTS AND NEEDLES IN **SINGER** MACHINES

The successful operation of SINGER machines can only be assured if SINGER parts and needles are used. Supplies are available at all SINGER Shops for the Manufacturing Trade, and mail orders will receive prompt attention.

SINGER Needles should be used
in SINGER Machines.
These Needles and their Containers
are marked with the
Company's Trade-Mark "SIMANCO.*" 1

Needles in Containers marked
"FOR SINGER MACHINES"
are NOT **SINGER** made needles. 2

DESCRIPTION

These machines have one needle and one looper and make the two-thread chain stitch. They are lubricated automatically, and the arm rotary shaft is counter-balanced and equipped with ball bearings for the intermediate and rear bearings adjacent to the balance wheel.

MACHINE 147-80 has a needle bar stroke of 1 1/8 inches and is adapted for general work in light weight material. Number of stitches to the inch is 10 to 25.

MACHINE 147-81 has a needle bar stroke of 1 7/32 inches and a greater feed lift and throw than Machine 147-80. It is adapted for seaming light and medium weight pants, seat covers, fabric gloves and similar work. Number of stitches to the inch is 6 to 25.

MACHINE 147-82 has a needle bar stroke of 1 5/16 inches and is used for seaming medium and medium-heavy pants, overalls and work of a similar nature. Number of stitches to the inch is 6 to 25.

MACHINE 147-84 has a needle bar stroke of 1 3/8 inches and is used for plain stitching on mattresses and studio couch work. Number of stitches to the inch is 6 to 18.

MACHINE 147-85 is similar to Machine 147-84, but is fitted for binding and plain stitching on mattresses and studio couches.

MACHINE 147-86 is similar to Machine 147-84, but is fitted for pants seaming on medium and heavy work.

To Set Up the Machine

Before placing the machine on the iron base, see that the rubber insulating bushings are in place in the four holes in the machine bed, and that the four felt pads are over the studs in the corners of the base. Place the machine on these pads, with the four studs through the rubber bushings.

CAUTION

AFTER SETTING UP, DO NOT START THE MACHINE UNTIL IT HAS BEEN THOROUGHLY OILED, AS INSTRUCTED ON PAGES 4 AND 5.

To Oil the Machine

These machines are equipped with an oiling system which automatically delivers the proper amount of oil to the principal bearings of the machine. (See large diagrams, pages 14 and 15).

Oil in the arm reservoir is splashed by the agitator on the connecting rod and lubricates the various bearings inside the arm. Cups within the arm distribute some of this oil through the connecting pipes and wicks to the principal bearings outside the arm.

IN ORDER THAT THIS SYSTEM MAY OPERATE, IT IS ABSOLUTELY NECESSARY THAT THE FOLLOWING INSTRUCTIONS BE OBSERVED TO THE LETTER. FAILURE TO DO THIS MAY RESULT IN SERIOUS DAMAGE TO THE MECHANISM OF THESE MACHINES.

Use "TYPE B" or "TYPE D" OIL, sold only by Singer Sewing Machine Company. For description of these oils, see inside front cover.

A MACHINE NEW FROM THE FACTORY, OR ONE THAT HAS NOT BEEN OPERATED FOR SOME TIME, MUST BE SERVICED AS FOLLOWS:

1st. Turn aside the cover (N, Fig. 3) and pour oil through the filler (P) until it reaches the oil level mark on the gauge in tube (A, Fig. 2). The oil in this tube indicates the oil level in the reservoir.

2nd. Prime the wicks at (O, Fig. 3) and at (C, B, H, G, F and E, Fig. 2) by filling the troughs with oil. When the machine is in daily use, no further hand oiling is required at these points as sufficient oil is supplied by the automatic lubricating system.

3rd. Fill oil holes at (S, Fig. 3) and at (D, Fig. 2).

4th. Apply a drop of oil at (J, Fig. 3).

5th. Fill the main oil pipe to **OVERFLOWING** through the oil hole at (M, Fig. 2).

NOTE: After the machine has been running at a moderate speed for about five minutes, it should be stopped and allowed to stand idle for a few minutes, then the oil in the reservoir should be checked and added to if necessary.

A MACHINE IN DAILY USE MUST BE SERVICED AS FOLLOWS:

1st. Check the oil level in the reservoir and, if low, add enough oil to bring it to the mark on the gauge in tube (A, Fig. 2). Never allow the oil in the reservoir to go more than 1/4 inch below the mark on the gauge.

2nd. Fill oil cup (D, Fig. 2) **LEVEL FULL** twice daily or as required.

3rd. Apply oil twice daily, or as required, to (S, Fig. 3).

NOTE: The slack thread regulator shaft and linkage on Machines 147-82, 147-84, 147-85 and 147-86 should be oiled twice daily.

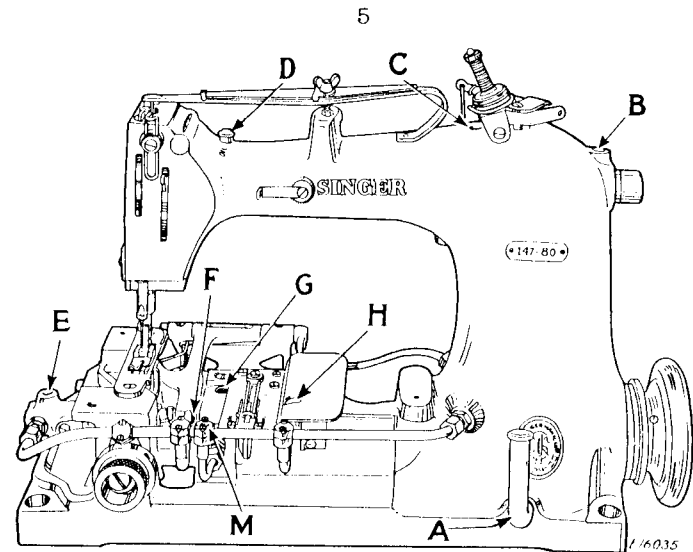

Fig. 2. Priming and Oiling Points at Front Side of Machine

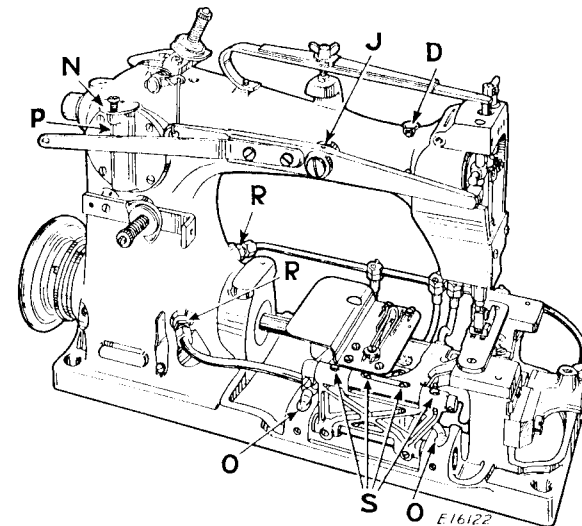

Fig. 3. Priming and Oiling Points at Rear Side of Machine

SPECIAL NOTICE

The letter "O" marked on oil pipe couplings (R, Fig. 3) must always be at the top. This is to insure that the oil spoon, attached to the inner end of the coupling, is open side up.

Speed

The maximum speed recommended for Machine 147-80 is 4300 R.P.M.; for Machines 147-81 and 147-82, 4000 R.P.M.; and for Machines 147-84, 147-85 and 147-86, 3800 R.P.M. The machines should be run somewhat slower than their maximum speed for the first few days until the parts which are in movable contact have become glazed by their action upon each other.

Needles

Needles for Machine 147-80 are of Class and Variety 62x47 and are made in sizes 13, 14, 16, 17, 18, 19, 20 and 21.

Needles for Machine 147-81 are of Class and Variety 62x43 and are made in sizes 13, 14, 16, 17, 18, 19, 20, 21 and 22.

Needles for Machines 147-82, 147-84, 147-85 and 147-86 are of Class and Variety 62x45 and are made in sizes 16, 17, 18, 19, 21, 22 and 23.

The size of the needle to be used should be determined by the size of the thread which must pass freely through the eye of the needle. The use of rough or uneven thread, or thread which passes with difficulty through the needle eye, will interfere with the proper operation of the machine.

Orders for needles must specify the Quantity required, the Size number; also the Class and Variety numbers separated by the letter x.

The following is an example of an intelligible order:

"100 No. 16, 62x47 Needles."

The best stitching results will be obtained when using the needles furnished by the Singer Sewing Machine Company.

To Set the Needle

Turn the balance wheel over from you until the needle bar moves up to its highest position, and loosen the set screw in the lower end of the needle bar. Place the needle up into the needle bar as far as it will go, with its single continuous groove toward you, then tighten the set screw.

Upper Threading on Machines 147-80 and 147-81

Pass the thread from the unwinder through the hole (1, Fig. 4) in the tension thread guide and between the tension discs (2) at the top

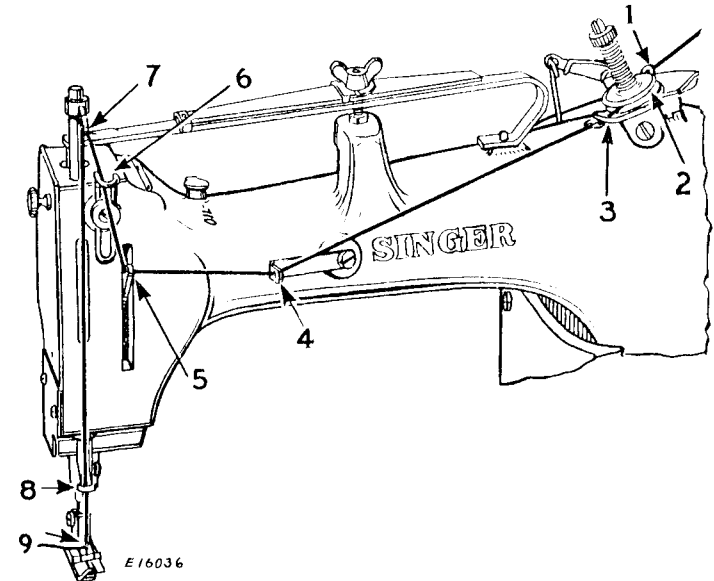

Fig. 4. Upper Threading

of the machine, through hole (3) in the tension thread guide, down through the eyelet in the thread guide (4), through eyelet in thread controller (5), up and through auxiliary thread take-up wire (6), through the hole in thread take-up (7), down through the hole (8) in the needle clamp and from front to back through the eye of the needle (9).

Draw about two inches of thread through the eye of the needle with which to commence sewing.

To Set the Needle Thread Take-up on Machines 147-80 and 147-81

When the needle bar is at its lowest point, the needle thread take-up (7, Fig. 4) should be set so as to have about 1/16 inch clearance from the upper needle bar bushing.

Upper Threading on Machines 147-82, 147-84, 147-85 and 147-86

Pass the thread from the unwinder through hole (1, Fig. 5) in the tension thread guide and between tension discs (2) at the top of the

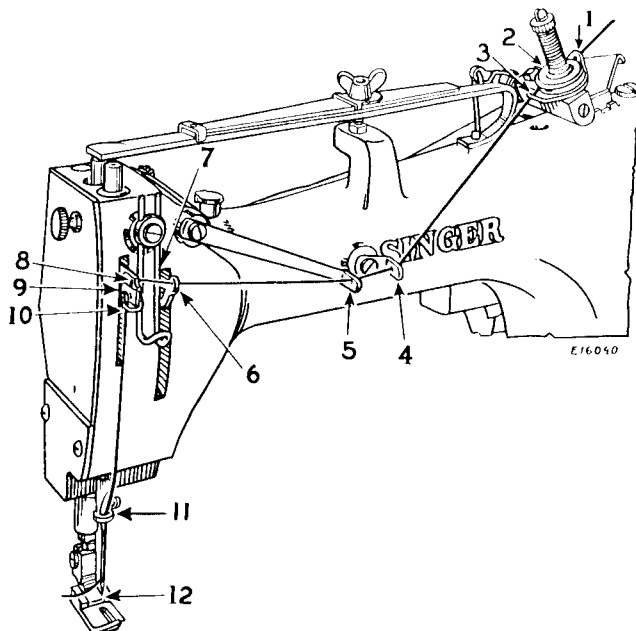

Fig. 5. Upper Threading

machine, through hole (3) in the tension thread guide, down through the thread guide (4), through eyelet in slack thread regulator (5), through eyelet in the thread controller (6), across front of auxiliary take-up wire (7) and through eyelet in thread take-up (8), under thread take-up plate (9), into the hole of thread guide (10), down through hole (11) in the lower end of the needle bar and from front to back through eye of needle (12).

Draw about two inches of thread through the eye of the needle with which to commence sewing.

To Set the Needle Thread Take-up on Machines 147-82, 147-84, 147-85 and 147-86

The needle thread take-up (8, Fig. 5) is usually set so that the bottom of the take-up is flush with the bottom of its holder.

Under Threading Operator Standing at the Front of the Machine (See Figs. 6 and 7)

Turn the balance wheel over from you until the needle bar moves down to its lowest point, then turn the knob (L, Fig. 7, page 10) to the left as far as it will go. This will bring the looper into position for threading.

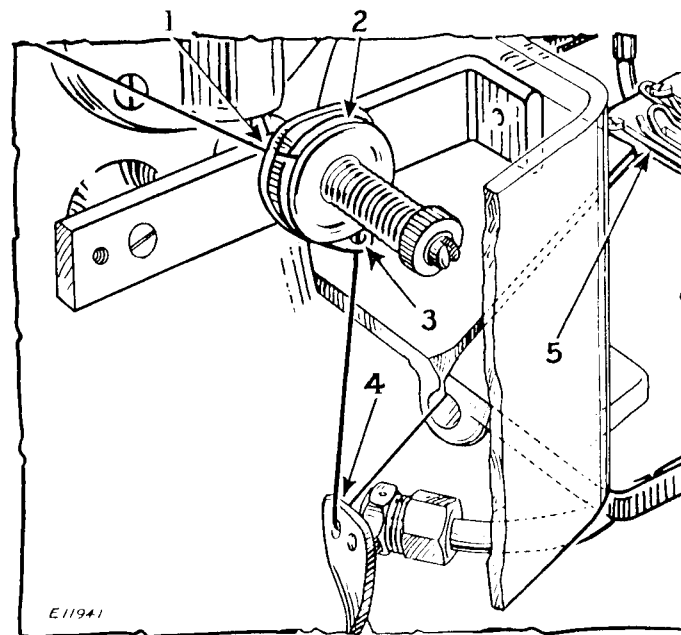

Fig. 6. Under Threading

Pass the thread from the unwinder through the hole (1, Fig. 6) in the tension thread guide at the rear of the machine, over between the tension discs (2), through hole (3) and down through the eyelet (4) in the thread guide that stands up from the bed of the machine. Pass the thread through the hole in the cloth plate guard and through the slot in the cloth plate. Then pass the thread through eyelet (5, Fig. 7),

under stripper (6), through eyelet (7), through hole (8) in the heel of the looper and from you through eye (9) of the looper.

Allow about two inches of thread to hang free from the eye of the looper with which to commence sewing and turn the knob (L, Fig. 7) back into sewing position.

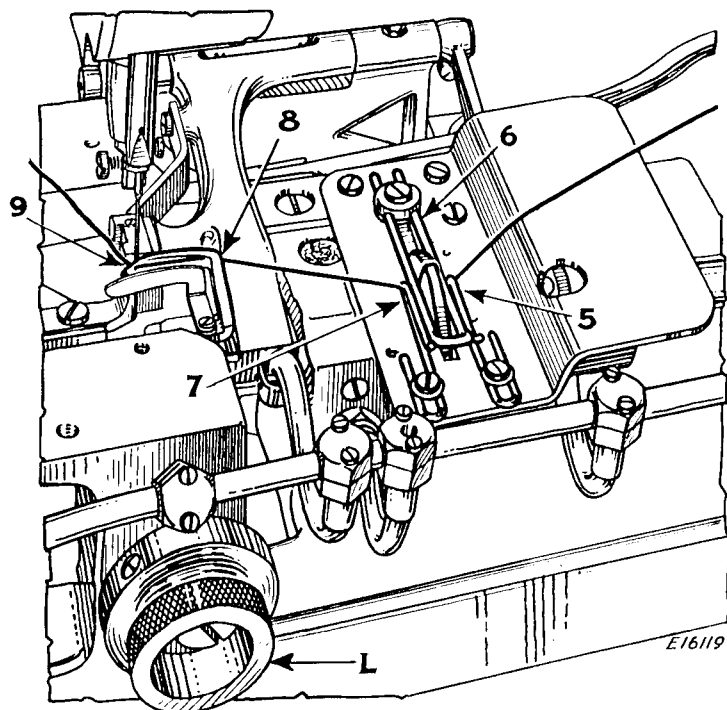

Fig. 7. Under Threading

To Regulate the Tensions

The tension on the needle thread is regulated by the thumb nut above the tension discs at the top of the machine. The needle thread requires sufficient tension to set the stitch properly in the goods.

The tension on the looper thread is regulated by the thumb nut at the back of the machine. The tension on the looper thread should be light, but sufficient to control the thread.

To Regulate the Pressure on the Material

The pressure of the presser foot on the material is regulated by means of the wing nut (D, Fig. 12, page 20) at the top of the machine. To increase the pressure, turn the wing nut (D) downward. To decrease the pressure, turn the wing nut upward.

To Regulate the Length of Stitch

The length of stitch is regulated by the large screw (A, Fig. 8) which projects beyond the body of the feed eccentric on the rotary

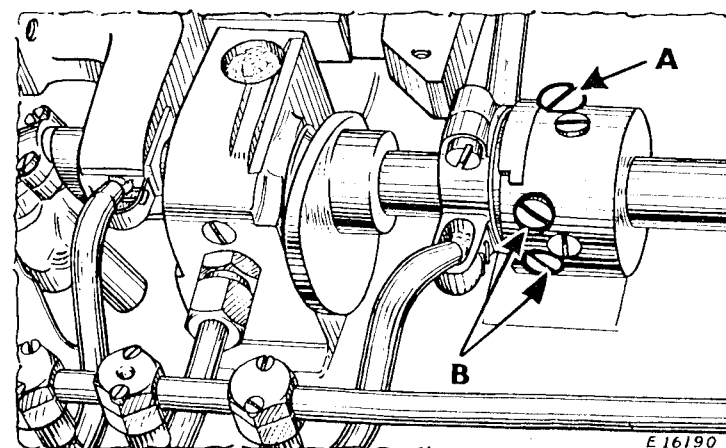

Fig. 8.

shaft. To increase the length of stitch, loosen the clamping screws (B, Fig. 8) and turn the large screw (A) over to the left or outward. To shorten the stitch, turn the large screw (A) over to the right or inward. When the desired length of stitch is obtained, securely tighten the clamping screws (B).

NOTE: If the machine is equipped with a movable needle guard, the guard must be reset as instructed on page 22 whenever the stitch length is changed.

To Set the Feed Dog at the Correct Height

When the feed dog is at its highest position, practically the full depth of the teeth should project through the slots in the throat plate. The height of the feed dog is determined by the stop screw (B, Fig. 14, page 22) which may be turned to the right or left as required after removing the feed dog. Note that the feed dog should always rest upon the stop screw (B).

To Level or Tilt the Feed Dog

The feed dog may be leveled, or tilted to any desired position after loosening feed dog screw (C, Fig. 14, page 22) and screw (A, Fig. 14).

When the feed dog is in the desired position, and resting upon the feed dog stop screw (B, Fig. 14), tighten feed dog screw (C), then tighten screw (A).

INSTRUCTIONS FOR ADJUSTERS AND MECHANICS

Diagrams
of Machine showing
wicks and bearings
oiled by automatic
splash, also bearings
oiled by gravity
through tubes on
outside of the
machine.

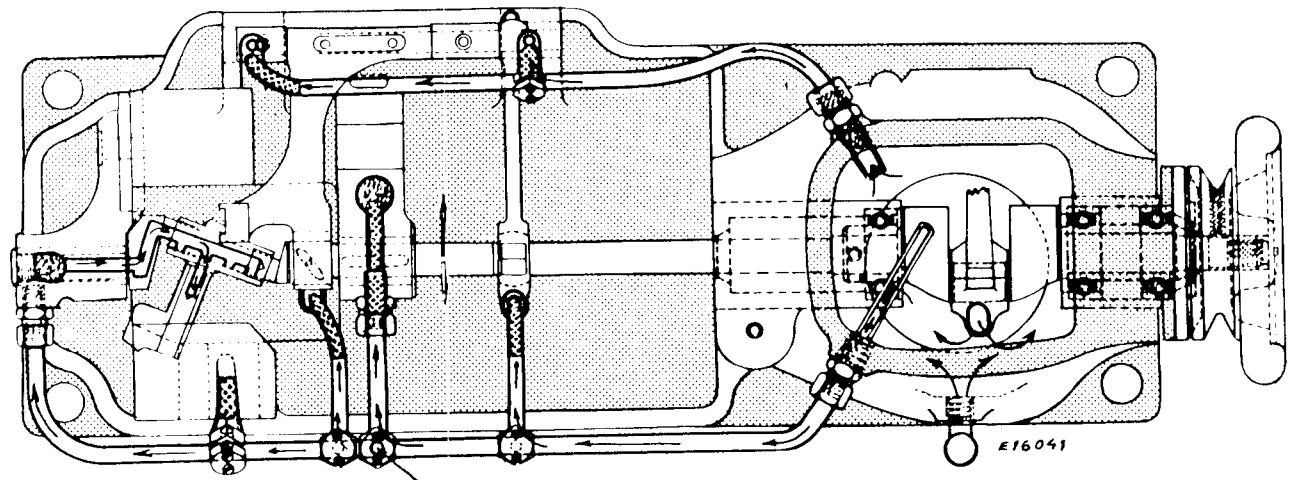
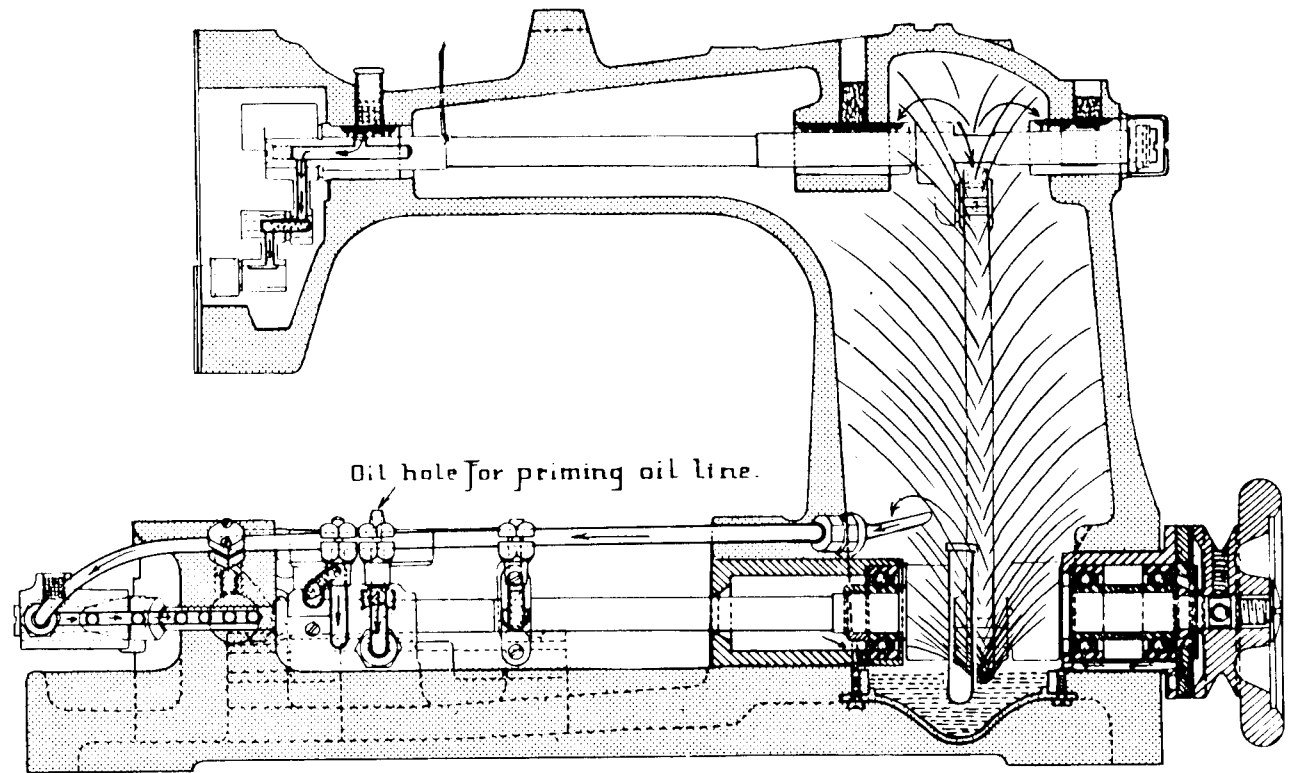

To Set the Loper the Correct Distance from Center of Needle

When the needle bar is at its lowest position, the distance from the center of the needle to the point of the looper should be $\frac{9}{64}$ inch.

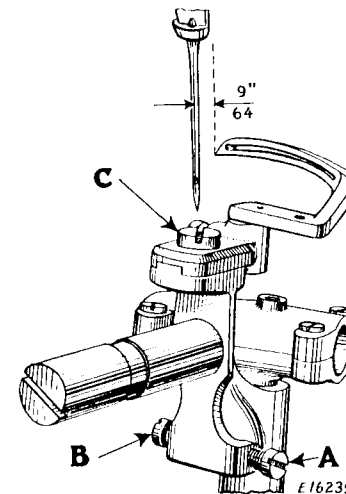

NOTE - When checking this distance, be sure that the looper is in its locked, or sewing, position. The correct position of the looper, for making this check, is insured by turning the knob (L, Fig. 7, page 10) over to the right (clockwise) as far as it will go. The only time when this knob (L) should be turned to the left (counter-clockwise) is to bring the looper into more convenient position for threading, as explained on page 9.

Fig. 9.

If the distance is less than $\frac{9}{64}$ inch, loosen the right hand screw (A, Fig. 9) in the looper holder bracket and tighten the left hand screw (B, Fig. 9). If the distance is more than $\frac{9}{64}$ inch, loosen the left hand screw (B) and tighten the right hand screw (A). When the correct distance from the center of the needle to the point of the looper is obtained, see that the two screws (A and B) are securely tightened.

To Change the Sidewise Position of the Loper in Relation to the Needle

The looper should be set to come equally close to the needle on its forward and backward strokes. To change the sidewise position of the looper in relation to the needle, loosen the screw (C, Fig. 9) and move the looper holder, as required, then securely tighten the screw (C).

To Set the Needle Bar in the Correct Position

Turn the balance wheel over from you until the point of the looper, on its forward stroke, reaches the center of the needle.

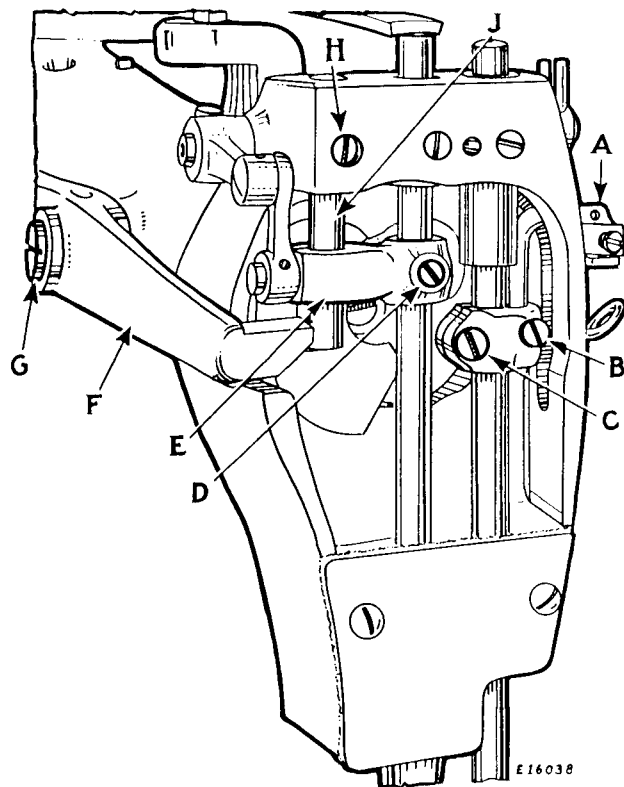

Fig. 10.

When the looper is in this position, the eye of the needle should be about $\frac{1}{8}$ inch below the point of the looper so that the eye of the needle and eye of the looper will be in perfect alignment when they pass each other on the loop-taking stroke. In case the needle bar is not set at the correct height, loosen the screw (C, Fig. 10) in the needle bar connecting stud and move the needle bar up or down, as required, then securely tighten the screw (C).

To Adjust the Slack Thread Regulator on Machines 147-82, 147-84, 147-85 and 147-86

The slack thread regulator (C, Fig. 11) on the front of the machine should be set so that when the looper is shedding the needle loop on its

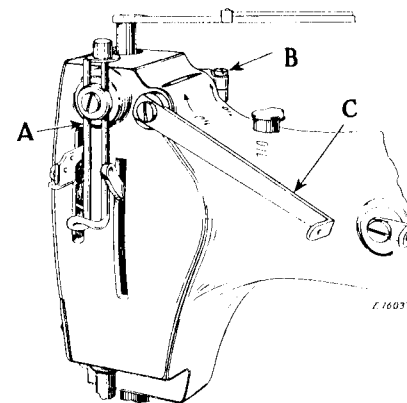

Fig. 11.

backward stroke, the thread will not snap from the point of the looper nor be drawn through the tension discs. To set the slack thread regulator, it is best to start with the regulator in a low position and then continue raising the regulator until the looper backs out of the needle loop with a little tension on the thread. To make this adjustment, loosen the clamping screw (B, Fig. 11) and raise or lower the slack thread regulator as may be required, then securely tighten the clamping screw (B).

To Adjust the Auxiliary Thread Take-up

The auxiliary thread take-up (A, Fig. 11) at the front of the machine should be set so that it takes up the slack of the needle thread after the looper has shed the needle loop and as the needle bar finishes its downward stroke and the stitch is set. To change the position of

the auxiliary thread take-up, loosen the screw which holds it in position and raise or lower it, as required, then tighten the screw.

For some threads it will be necessary to set the auxiliary thread take-up at a height different from that required by others, owing to the difference in finish, twist, elasticity, etc.

To Adjust the Needle Thread Tension Releaser

The function of the needle thread tension releaser is to release the tension on the needle thread when the presser foot is raised.

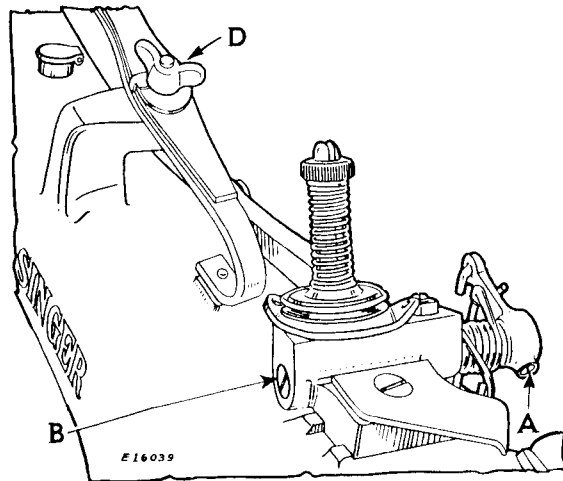

Fig. 12.

If the tension releaser does not release the thread when the presser foot is raised, or if the tension is partially released when the presser foot is down, loosen the set screw (A, Fig. 12) and turn the shaft (B, Fig. 12) to the right or left until the correct adjustment is obtained, then tighten the set screw (A).

To Adjust the Under Thread Guides

The purpose of the thread guides (B, Fig. 13) is to position the threads on the rotary take-up. The guides (B) should be set about flush with the front edge of the stripper plate as shown in Fig. 13.

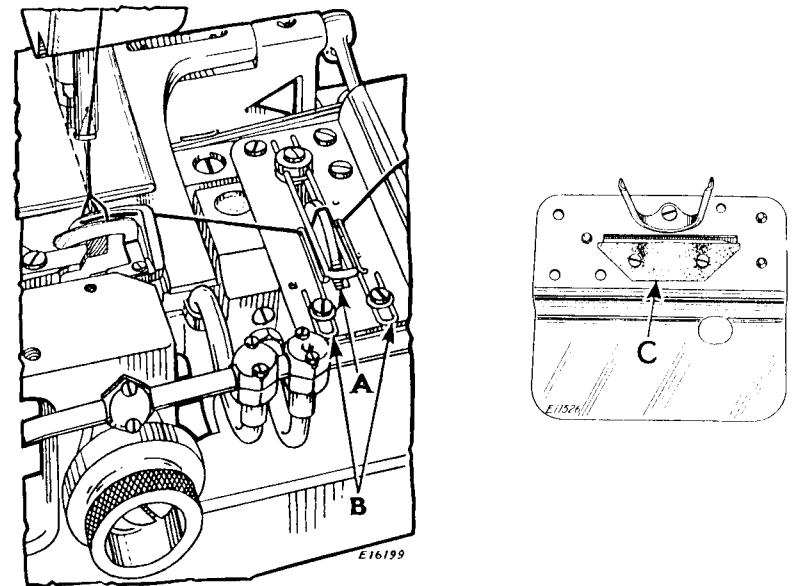

Fig. 13.

To Time the Under Thread Take-up

The looper thread take-up should be set to contact the thread just as the looper is commencing its backward stroke or loop shedding motion and keep the thread taut until the point of the needle, on its downward stroke, has entered the triangle formed by the looper blade, the looper thread and the needle loop (Fig. 13). The looper thread take-up (A) can be correctly timed after loosening the screw which holds it in position on the rotary shaft.

Under Thread Rotary Take-up Guard (Fibre)

The underside view, included in Fig. 13, of the stripper plate shows the fibre guard (C) attached. The take-up should be set in close contact to this guard to prevent the ends of the thread, in case of breakage, from being carried around the take-up.

To Set the Movable Needle Guard

The function of the needle guard (D, Fig. 14) is to prevent the needle springing into the path of the looper when the looper is on its forward stroke. If the machine is equipped with a movable needle guard, the guard must be reset each time the stitch length is changed.

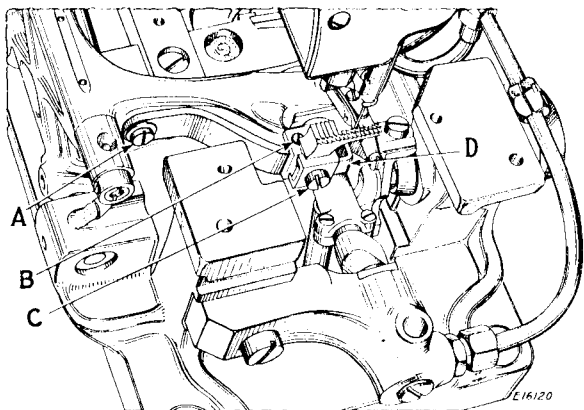

Fig. 14.

Use caution when setting the movable needle guard as it is attached to the feed bar and should be set only when the feed is all the way forward and the needle is on its upstroke.

To set the movable needle guard, loosen screw (C, Fig. 14) and move the needle guard (D) toward or away from the needle so that the guard is as close as possible to the needle without actually touching it.

Press the feed dog down upon the stop screw (B, Fig. 14), then tighten the screw (C).

To Set the Stationary Needle Guard

The stationary needle guard should be set as close as possible to the needle without actually touching it. To set the stationary needle guard, loosen the set screw (L, Fig. 19, page 26) and move the guard (C, Fig. 19) to or from the needle, as may be required, then securely tighten the set screw (L).

The stationary needle guard can be adjusted sidewise to clear the feed dog after loosening the screw (A, Fig. 19).

The function of the needle guard is to prevent the needle springing into the path of the looper when the looper is on its forward stroke.

To Change the Amount of Needle-Avoiding Motion of the Looper

The amount of sidewise movement of the looper is regulated by moving the rotary shaft endwise, toward the needle for less sidewise motion

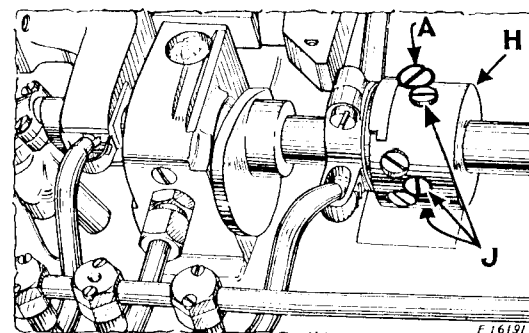

Fig. 15.

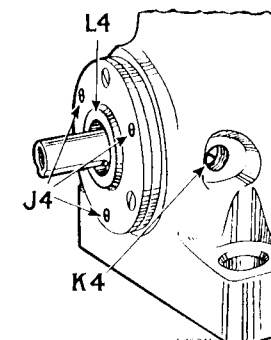

Fig. 16.

and away from the needle for more sidewise motion. The looper should pass as close to the needle as possible on its forward and backward stroke, without touching the needle. To adjust, loosen the set screw in the under thread take-up which holds it in position on the rotary shaft; also loosen the three set screws (J, Fig. 15) in feed eccentric (H, Fig. 15), and loosen the two screws (E Fig. 17, page 24) in the rock shaft crank. Take off the balance wheel by loosening the two set screws in the groove and removing the cap screw. Loosen ball bearing case screw (K4, Fig. 16). To move the rotary shaft toward the needle, turn three position screws (J4, Fig. 16) uniformly inward, and tap ball bearing case (L4) until desired amount of sidewise motion is obtained. To bring the shaft away from the needle, turn the three position screws outward, as evenly as possible, then tighten ball bearing case screw. Replace balance wheel. Turn the balance wheel a few times by hand to allow rock shaft and feed eccentric to align themselves, then securely tighten screws (E, Fig. 17) against their flats; time the feed eccentric (H, Fig. 15) as instructed below, then time the under thread take-up as instructed on page 21.

To Time the Feed

For correct timing of the feed, the first two of the three screws (J, Fig. 15) must be tightened against the two flats on the rotary shaft. The first of these three screws is the one nearest the stitch regulator screw (A, Fig. 15), the second being the one which follows the first when the balance wheel is turned over from the operator. After tightening these two screws against their flats, tighten the third screw against the shaft. Then time the under thread take-up as instructed on page 21.

To Centralize the Feed Dog in the Throat Plate Slots

The feed dog should be centered in the throat plate slots so that it moves equi-distant from both ends of the slots during its feeding movement.

To centralize the feed dog, loosen clamp screw (B, Fig. 18) and rotate the hinge pin (D), as required. Then tighten clamp screw (B).

To Align the Feed Dog in the Throat Plate Slots

Loosen the three screws (J, Fig. 15, page 23) in the feed eccentric (H, Fig. 15), also loosen the two set screws (E, Fig. 18) in the feed rocking frame bushings. Then tap the inside edge of the feed frame lug at (F) to move the feed dog to the left, or tap at (G) to move it to the right.

Take out excessive end play by tapping the opposite bushing toward the feed frame, but use caution when making this adjustment as there should always be a slight amount of end play between the two bushings.

To Remove the Arm Rock Shaft

Remove the face plate and needle, and take out the needle screw from the needle bar. Loosen set screw (B, Fig. 10, page 18)

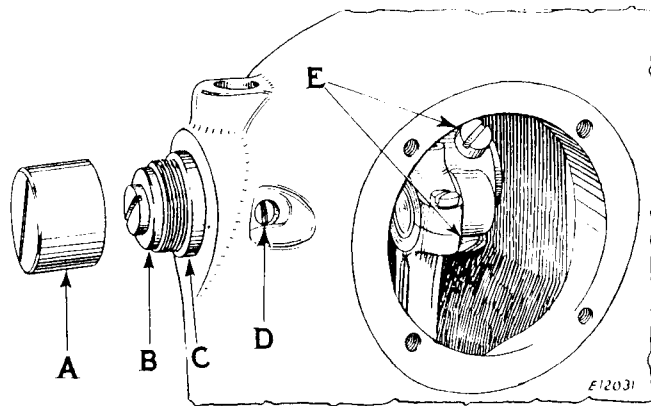

Fig. 17.

and remove the thread take-up (A, Fig. 10). Loosen screw (C, Fig. 10) and remove the needle bar from the top of the machine.

Remove the presser foot and presser foot screw, then loosen screw (D, Fig. 10) and take out the presser bar from the top of the machine. Loosen screw (H, Fig. 10) and remove presser bar

guide (J, Fig. 10), and presser bar lifting bracket (E, Fig. 10). Take out the needle bar connecting link. Take out screw (G, Fig. 10) and remove foot lifting lever (F, Fig. 10).

Remove cap (A, Fig. 17) and screw and washer (B, Fig. 17) at the end of the rock shaft. Remove the round cover plate at the back of the arm, carefully saving the gasket. Loosen the two screws (E, Fig. 17) in the rock shaft crank and, with the connecting rod at the midway point, withdraw the rock shaft from the needle bar end of the arm.

When replacing the rock shaft, have the connecting rod at the midway point. Replace screw and washer (B, Fig. 17) in the end of the shaft, then turn the balance wheel a few turns by hand to allow the rock shaft to align itself before tightening the two screws (E) on their flats.

The amount of end play in the rock shaft is regulated by loosening set screw (D) and moving bushing (C) endwise. Use caution when making this endwise adjustment, as there should be a little end play in the rock shaft when cold to allow for expansion which takes place when the machine is warmed up.

To Remove the Feed Mechanism

Remove the presser foot, cloth plate, throat plate, needle guard and feed dog. Loosen the clamp screw (B, Fig. 18) in the feed connecting

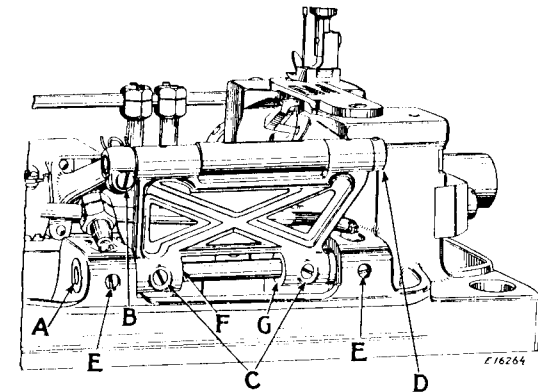

Fig. 18.

rod and slip the feed bar hinge pin (D, Fig. 18) out far enough to release the connecting rod. Loosen the two set screws (C, Fig. 18) in the feed rocking frame and remove the hinge pin (A, Fig. 18). The feed assembly can now be removed from the machine.

After replacing the feed mechanism, the feed dog should be centered in the slots in the throat plate as instructed on page 24.

To Remove the Loper Mechanism

Remove the presser foot, throat plate, thread guard, cloth plate and feed dog.

Take out the screw (E, Fig. 19) and remove the looper holder

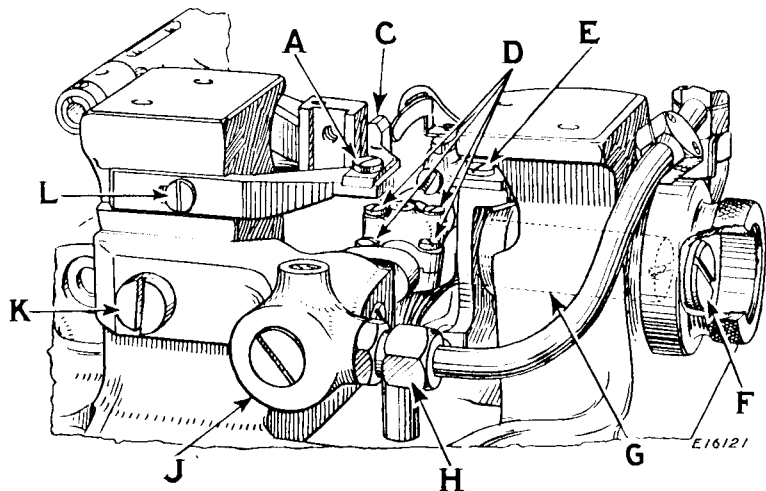

Fig. 19.

together with the looper. Take out the screw (L, Fig. 19) and remove the needle guard holder. Take out the four screws (D, Fig. 19) in the looper shaft connection and remove the cap. Remove the cap screw (F, Fig. 19), then insert a screwdriver into the hole and unscrew the shaft (G, Fig. 19) from the looper carrier. Remove the looper assembly from the machine.

To Remove the Loper Shaft

(See Fig. 20)

To remove the looper shaft (M, Fig. 20) from the machine, first remove the feed bar as instructed under "To Remove Arm Rotary Shaft", page 27. Unscrew the oil pipe coupling nut (H, Fig. 19), take out the screw (K, Fig. 19) and remove the bracket (J, Fig. 19), then turn the balance wheel until the looper shaft screw (N, Fig. 20) is at the top. Take out this screw and remove the looper shaft from the rotary shaft by tapping the flange of the feed eccentric (P, Fig. 20) with a piece of brass. Be careful not to spring this shaft when removing or replacing it, as this would cause it to bind and heat when the bracket (J) is replaced.

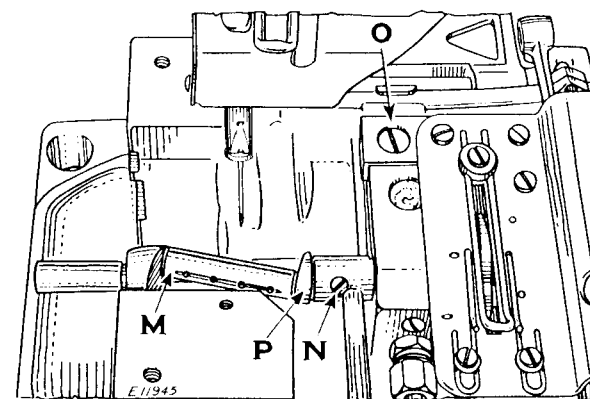

Fig. 20.

To Remove the Arm Rotary Shaft

Remove the presser foot, needle, cloth plate, throat plate and feed dog. Take out screw (E, Fig. 19) and remove the looper

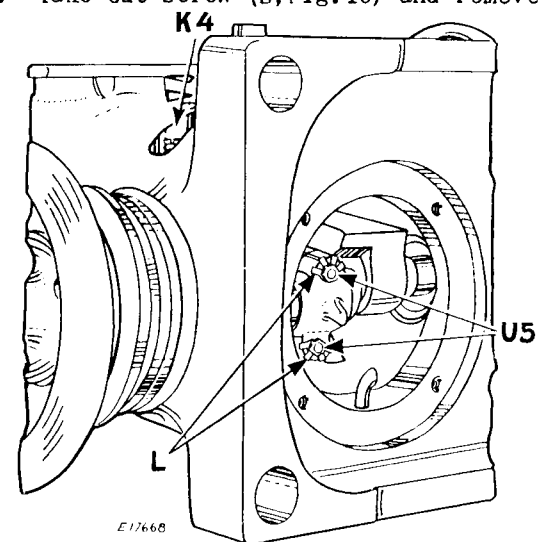

Fig. 21.

holder together with the looper. Take out screw (O, Fig. 20) and remove the stripper plate and bracket. Loosen the clamp screw (B, Fig. 18, page 25) in the feed connecting rod and slip out the feed bar hinge pin (D, Fig. 18) and remove the feed bar. Remove

the screw (N, Fig. 20) which holds the looper shaft to the rotary shaft. Remove the oil sump at the under side of the machine bed, being careful to prevent injury to the gasket. Through the opening thus exposed (see Fig. 21), take out the two hexagon nuts (U5, Fig. 21) together with the lock washers (L, Fig. 21), and remove the connecting rod cap. Loosen the three set screws (J, Fig. 15, page 23) in the feed eccentric (H, Fig. 15), also loosen the set screw in the hub of the looper thread take-up (A, Fig. 13, page 21). Loosen the ball bearing case screw (K4, Fig. 21) and tap the inside rim of the balance wheel to remove the rotary shaft together with the ball bearing case.

When making replacement, tighten the three set screws (J, Fig. 15) in the feed eccentric (H, Fig. 15) in the order mentioned under "To Time the Feed" page 23. Make certain that the flat of the ball bearing case is in such position that the ball bearing case screw (K4) will be tightened against it.

To replace the connecting rod cap, first have the two cap screws in place, then apply the lock washers (L, Fig. 21), then the hexagon nuts (U5). Do not tighten these nuts too much as this would cause binding of the shaft. When the nuts (U5) have been properly tightened, bend up the lugs of the washers (L). Also make sure, in replacing the sump, that the gasket is properly in place, to prevent leakage of oil, before tightening the four fastening screws.

SINGER Needles should be used
in SINGER Machines.
These Needles and their Containers
are marked with the
Company's Trade-Mark "SIMANCO.*" 1

Needles in Containers marked
"FOR SINGER MACHINES"
are NOT **SINGER** made needles. 2