

SINGER
114w103 & 114w104

USE SINGER' OILS and LUBRICANTS

They insure freedom from lubricating trouble and give longer life to sewing equipment

The following are the correct lubricants for this machine:

TYPE B — MANUFACTURING MACHINE OIL, HEAVY GRADE

When an oil is desired which will produce a minimum of stain on fabrics, even after a long period of storage, use:

TYPE D — MANUFACTURING MACHINE OIL, HEAVY GRADE

OTHER SINGER LUBRICANTS

TYPE E — THREAD LUBRICANT

For lubricating the needle thread of sewing machines for stitching fabrics or leather where a thread lubricant is required.

TYPE F — MOTOR OIL

For oil lubricated motors and plain bearings in power tables and transmitters.

NOTE: All of the above oils are available in 1 quart, 1 gallon and 5 gallon cans.

GEAR LUBRICANT

This specially prepared grease is recommended for gear lubrication on manufacturing sewing machines.

BALL BEARING LUBRICANT

This pure grease is specially designed for the lubrication of ball bearings and ball thrust bearings of motors and electric transmitters, ball bearing hangers of power tables, etc. Furnished in 1 lb. and 4 lb. tins.

1594w

INSTRUCTIONS FOR USING **SINGER*** SEWING MACHINES 114w103 AND 114w104

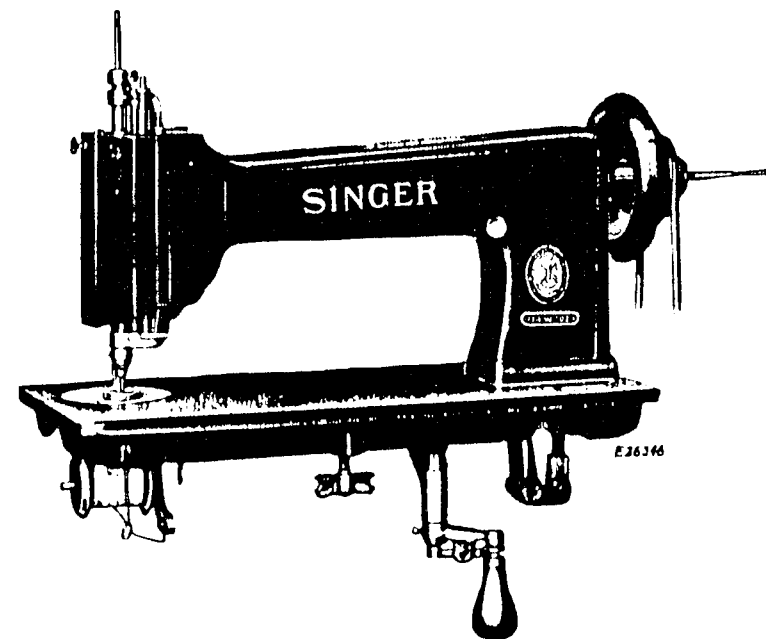

THE SINGER MANUFACTURING COMPANY

*A Trade Mark of THE SINGER MANUFACTURING COMPANY

DESCRIPTION

Machine 114w103 makes the single thread chain stitch and can be quickly adjusted to make the drop or moss stitch without unthreading the machine. It is designed for ornamenting or embroidering curtains, upholstery, cloaks, dresses, mantel scarfs, glove backs, table covers, lace, etc. The machine also can mark linen and towels for hotels, etc., by stitching a name into the material.

The thread may be of cotton, wool, worsted, silk, metal and other threads of similar adaptability. A large variety of fabrics can be embroidered, ranging from fine chiffon to china silk and cloth.

The usual method of producing embroidered designs is to follow a pattern that has been perforated, stamped or traced on the fabric, but with practice the operator can produce embroidery designs without pre-marking the fabric.

Machine 114w104 differs from **Machine 114w103** only in that it is adapted for heavier work, such as army blankets, etc.

SPEED

When first operating these machines, the best results can be obtained by running the machines at approximately 600 stitches per minute. The speed can be increased as the operator becomes more proficient and the nature of the work permits.

TO OIL THE MACHINE

To insure easy running and prevent unnecessary wear of the parts which are in movable contact, the machine requires oiling.

Use "TYPE B" or "TYPE D" OIL, sold by Singer Sewing Machine Company. For description of oils, see inside of front cover of this book.

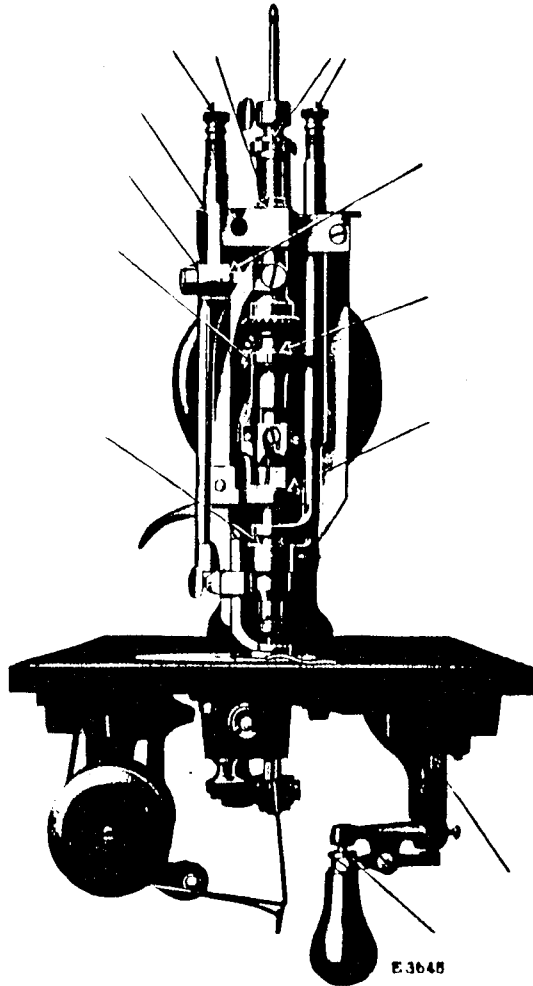

Fig. 2. End View of Machine Showing Oiling Points

Oil should be applied to the places designated by unlettered arrows in Figs. 2, 3, 10 and 11.

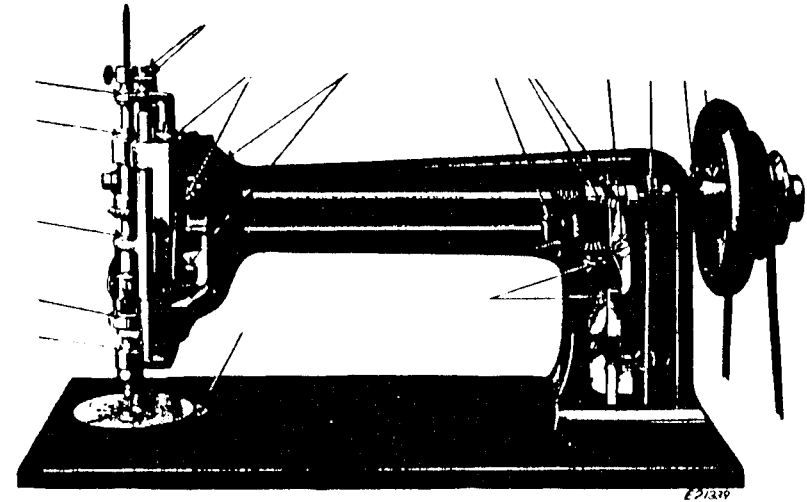

Fig. 3. Oiling Points at the Front of the Machine

Fig. 3 shows the arm cover removed for the purpose of oiling. This arm cover can be removed after taking out thumb screw W, Fig. 9.

If the machine is used continuously, oil should be applied at least once each day.

NEEDLES, NIPPLES AND THREAD

Needles for Machines 114w103 and 114w104 are of Class and Variety 137 x 1, and are furnished in special number Sizes from 1 to 12. These needles have hooks similar in appearance to those of hand crochet needles.

The needle must be selected according to the thickness and the style of the thread to be used. The thread must not only fill the opening of the hook in the needle but must slide freely therein.

To correspond with the needle used in the machine a suitable nipple must be selected, as the needle in forming the stitch has to operate through the nipple. The needle must fit in the nipple and slide freely without side play. Nipples are furnished in size numbers similar to those of the needles, viz., 1 to 12, and for general work the number of the nipple should be the same as that of the needle.

NOT REG. IN M/C ANY MORE ⁶ ¹¹ ³ ¹⁰
 TO WIND THE SPOOL ON MACHINE NO. 114w103

Remove the screw at the right of the machine pulley, then screw into the machine pulley the taper spindle V, Fig. 9 for winding the spool (six special spools are furnished with each machine).

Place the machine spool on the taper spindle V, Fig. 9 and push it on as far as it will go. Wind the embroidery thread evenly on the spool, the thread being taken from a cone or spool, held by the hand.

TO REMOVE, REPLACE AND SET NEEDLE AND NIPPLE

When it is necessary to change the needle and nipple on the machine, first select another needle and corresponding nipple. Then lower the presser bar, loosen wing screw B, Fig. 4 and remove needle holder A and needle from top of machine. Unscrew nipple N, using the small wrench provided.

Select the correct needle hole in needle plate D.

NOTE: The needle hole should be slightly larger than the needle, so that the thread, when laid around the needle, will have sufficient space to pass without touching the sides of the needle hole.

Loosen thumb screw L and turn plate D until correct needle hole is in line with needle, then tighten thumb screw L.

Next, screw selected nipple into the lower end of nipple carrier O and tighten securely with the small wrench. Screw selected needle into either end of needle holder A and tighten with pliers provided. Replace needle holder A down into sleeve and adjust its height so that the fabric to be embroidered can just pass under the point of the needle.

Be sure handle K is as far to the front as possible and that the hook of the needle faces the front. Then tighten wing screw B, which also should face the front.

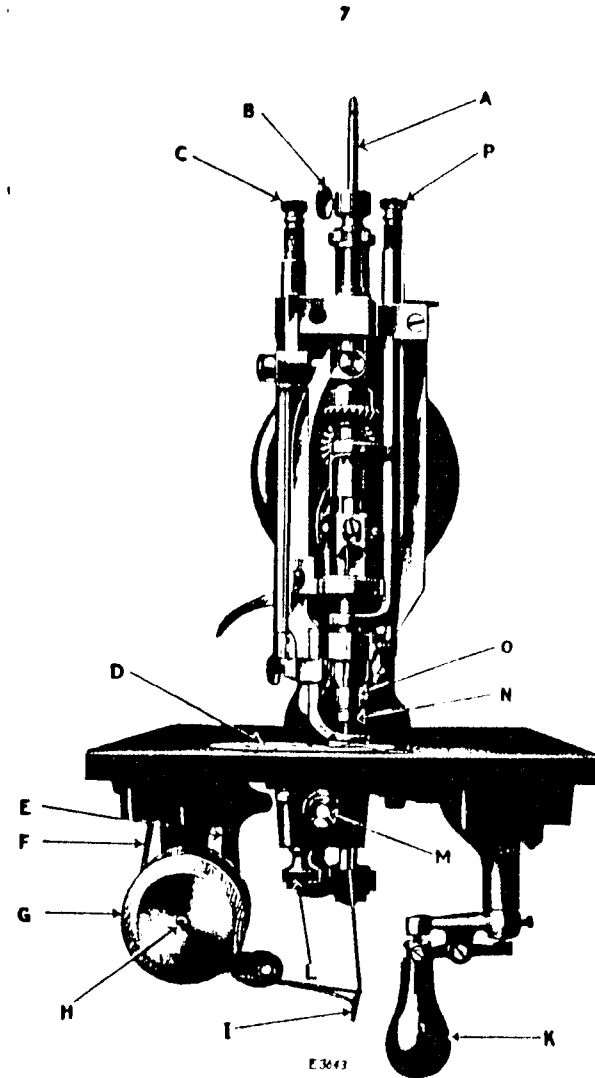

Fig. 4. Adjustments on the Machine

- | | |
|--|--|
| A. Needle Holder | I. Thread Controller |
| B. Wing Screw for Needle Holder | K. Handle for Directing Feed and Operating Stop Motion |
| C. Thumb Screw for Regulating Pressure on Presser Foot | L. Thumb Screw for Holding Needle Plate |
| D. Needle Plate | M. End of Looper Shaft |
| E. Lever for Regulating Tension on Spool | N. Nipple |
| F. Tension Blade | O. Nipple Carrier |
| G. Spool | P. Thumb Screw for Regulating Pressure on Nipple |
| H. Spool Pin | |

TO THREAD MACHINE 114w103

Place spool G, Fig. 5 on spool pin H with thread drawing from underside of spool. Draw thread from spool to thread controller I, turn handle K to the front or slightly to the left, raise presser foot and insert threading wire S in the forward hole of needle plate. With the left hand, catch thread on hook of threading wire S and draw wire and thread up through hole of needle plate. With the left hand, hold end of thread with a slight tension.

With the right hand, turn handle K straight to the left and, having started the machine, quickly bear down and up on handle K so that the needle will pick up the thread for one stitch. Keep handle K in same position and, with the threading wire, draw thread directly toward you, laying end of thread loosely on needle plate after it comes up through needle hole. The machine is then ready for operation.

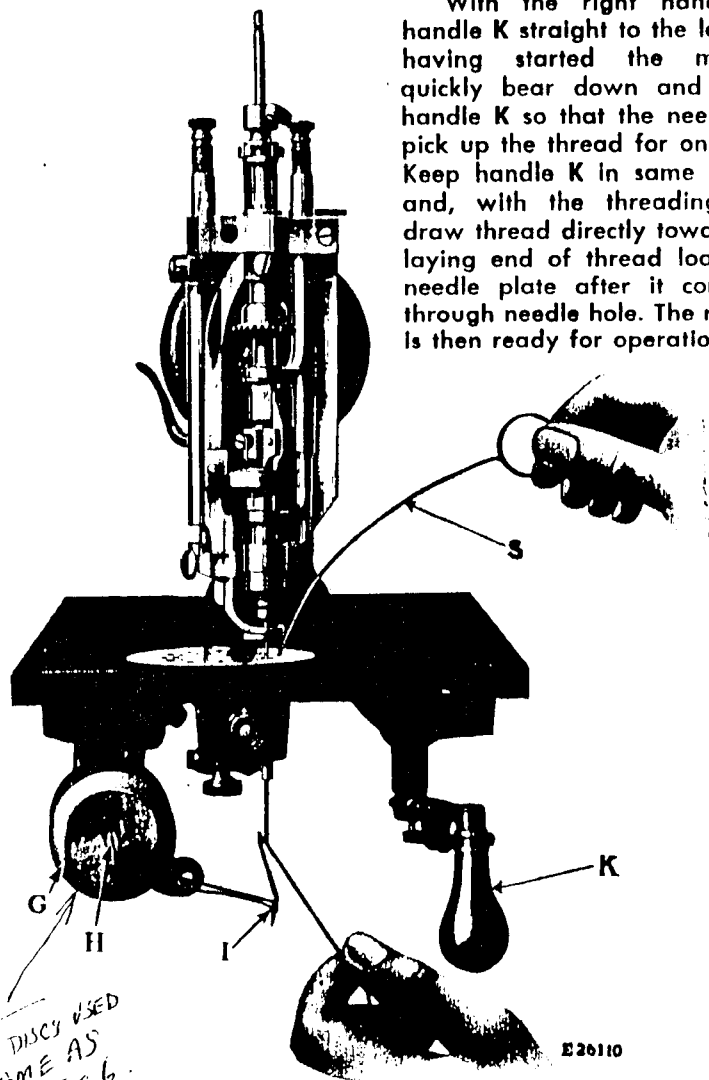

Fig. 5. Threading Machine 114w103

REG
TYPE
TENSION DISCS USED
W-SAME AS
1107 FIG 6.

TO THREAD MACHINE 114w104

Place the cone of thread in a convenient position on the floor.

Three thread eyelets are furnished with the machine. These eyelets should be fastened to the underside of the table as shown at 1, 2 and 3, Fig. 6. Eyelet 1 should be located directly above the cone of thread.

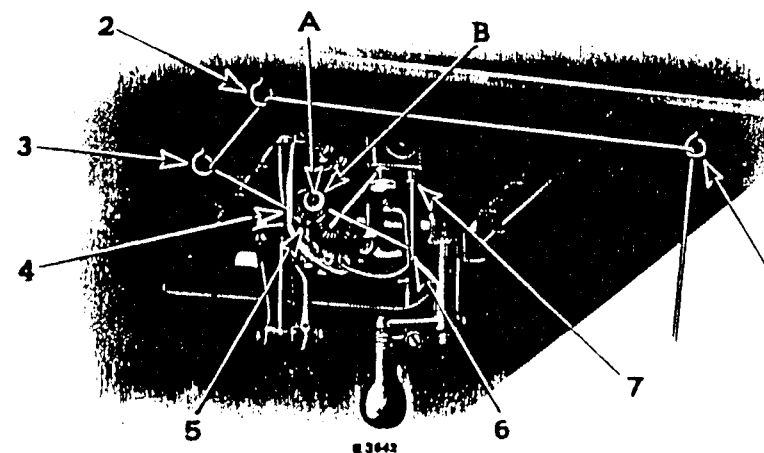

Fig. 6. Threading Machine 114w104

Pass the thread up from the cone and through eyelets 1, 2 and 3, then through hole 4, over between tension discs 5, through thread controller 6 and then up through hole 7, as instructed for Machine 114w103.

When desired, Machine 114w104 can be used with a small spool of thread by inserting spool pin (furnished with each machine) in place of tension stud A, Fig. 6. In this case, the threading will be the same as for Machine 114W103.

LEARNING TO OPERATE THE MACHINE

NOTE: When in operation the machine pulley must always turn over away from operator.

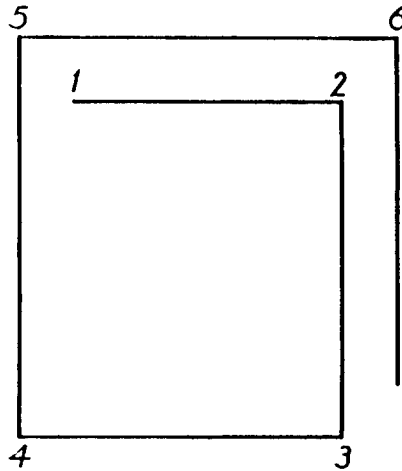

Fig. 7. Diagram for Practice

Mark a design (see Fig. 7) on a 12 inch square piece of cloth. Place cloth under presser foot so that needle will enter cloth at point 1. Turn handle K, Fig. 4 to the right and the hook of the needle will be turned in the same direction. Lower presser foot, start machine pulley by turning it over away from you, grasp handle K and pull it down to start the machine. With handle depressed and to the right, cloth will be fed to point 2; then turn handle to the front and cloth will be fed to point 3; turn handle to the left and cloth will be fed to point 4, etc.

To stop machine raise handle K. Machine will stop with needle at its highest point.

TO OPERATE THE MACHINE

The operator should practice embroidering designs similar to those illustrated below.



Fig. 8. Designs for Beginners

These designs can be sketched on white material such as lawn, and by following them, the operator can soon become proficient enough to attempt more intricate designs or patterns.

TO REGULATE THE PRESSURE ON THE PRESSER FOOT

The pressure on the presser foot is regulated by the thumb screw C, Fig. 4. To increase the pressure, turn the thumb screw over to the right or downward. To decrease the pressure, turn the thumb screw over to the left or upward.

TENSIONS

If stitches are too tight, raise needle holder approximately 1/16 inch.

Various effects can be produced by changing the height of the needle holder as well as by adjusting the length of stitch.

On Machine 114w103 the tension on the spool is regulated by the tension blade F, Fig. 4, which is adjusted by the lever E, Fig. 4, at the right of the spool. This tension should be only tight enough to prevent the skipping of stitches.

On Machine 114w104 the tension on the thread is regulated by the thumb nut B, Fig. 6, at the left of the tension discs. To increase the tension turn this nut over toward you. To decrease the tension turn this thumb nut over from you. This tension should be only tight enough to prevent the skipping of stitches.

TO ADJUST THE LENGTH OF STITCH

The length of stitch is adjusted by screw **T**, Fig. 9. To lengthen the stitch, loosen locking lever **U** and turn screw **T** over to the left, or upward, then tighten locking lever **U**.

To shorten the stitch, loosen locking lever **U** and turn the screw **T** over to the right, or downward, then tighten locking lever **U**.

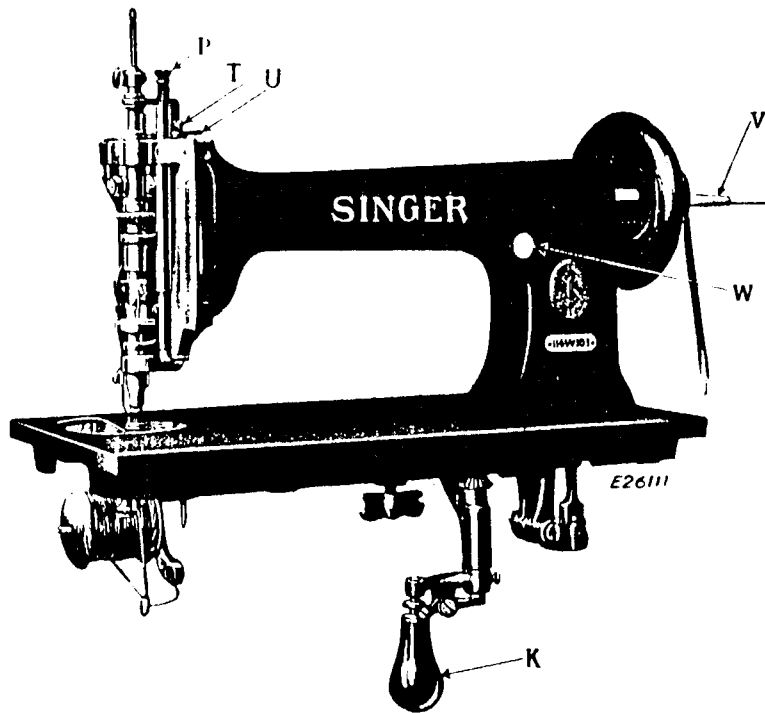

Fig. 9. Adjustments on the Machine

TO REGULATE THE PRESSURE ON THE NIPPLE

The pressure on the nipple is regulated by the thumb screw **P**, Fig. 9 at the top of the machine. To increase the pressure, turn this thumb screw over to the right or downward. To decrease the pressure, turn this thumb screw over to the left or upward.

NOTE: Too much pressure on the nipple may cause the thread to break.

When sewing fine net, it is sometimes necessary to prevent the nipple from touching the needle plate.

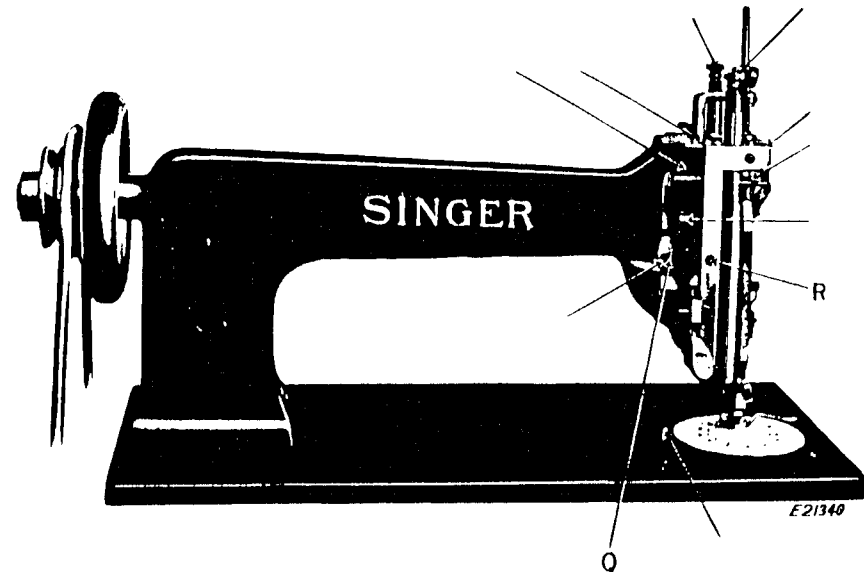

Fig. 10. Oiling Points and Adjustments at the Back of the Machine

To raise the nipple, insert a screw driver in hole **R**, Fig. 10, and loosen the set screw therein. The eccentric adjusting stud **Q** can then be turned so that the nipple can be set at the desired height; then tighten the set screw in hole **R**.

THE LOOPER

Allow the stop motion to throw the machine out of action and make sure that it is securely held in its locking position. Raise the needle holder to avoid breaking the point of the needle, remove the needle plate after removing the thumb screw **L**, Fig. 11, and

observe the notch in the looper which, when in its correct position should be at the rear, slightly to the right of the needle on Machine 114w103, and at the rear about 3/16" to the left of the needle on Machine 114w104, while the handle K is toward the front.

TO SET THE LOOPER

Turn the machine back on its hinges and turn handle K, Fig. 11, and wing screw B, Fig. 4 to the front. Loosen set screw X, Fig. 11 of the operating worm gear Y, and turn the gear slightly, until the notch in the looper is in its correct position as instructed above. After having set the worm gear flush with the end of the looper shaft M, tighten the set screw X.

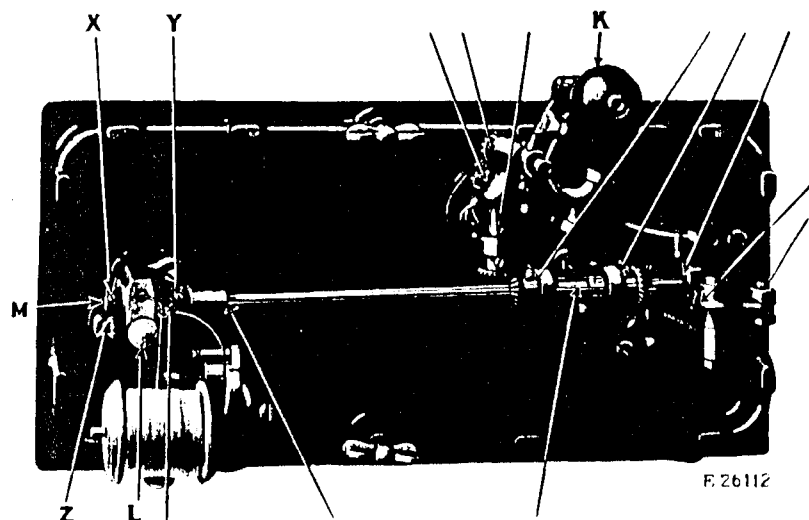

Fig. 11. Oiling Points and Adjustments in Base of Machine

PILE OR MOSS STITCH

The raised pile or moss stitch is produced by adjusting the machine so that it will drop the stitches in loose loops on the material. To accomplish this, turn handle K to the front, loosen the wing screw B, Fig. 4 and turn the needle holder so that the hook of the needle will point directly to the back of the machine, then tighten the wing screw.

Reach under the bed of the machine with the left hand, grasp the knurled end Z, Fig. 11, of the operating worm gear, draw the worm gear to the left and while holding it turn handle K around

to the right directly to the back, then release the knurled end of the gear.

The looper will then be set in the opposite direction to that which is required for the chain stitch, or with the notch of the looper at the front of the needle while handle K is at the front.

By operating the machine and turning handle K rapidly, so as to make very small circles of dropped stitch loops laid one on the other, raised pile work is produced. The higher the needle is set the longer the loop will be. The size of the thread and thickness of the material used will have to be considered when adjusting the machine for pile stitching.

TO EMBROIDER WITH WOOL THREAD

Set a No. 7 needle and a No. 8 nipple in the machine, turn the needle plate so that a large needle hole will be under the needle and proceed with the work.

The size of the thread used for embroidery, its finish and color, have much to do with producing varied embroidered effects on manufactured articles, and the needle and nipple should match each size of thread.