

**SINGER**  
**11W3,W4,W5**

1250 w

# INSTRUCTIONS

FOR USING

## Singer Sewing Machines

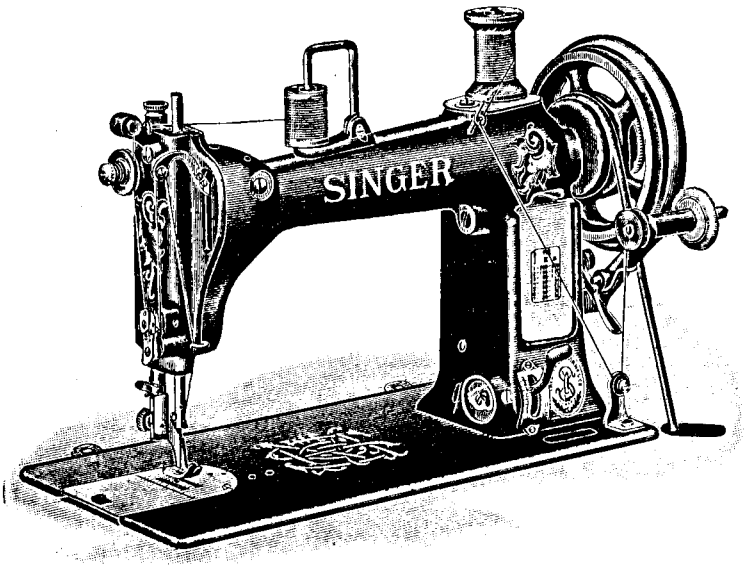

Machine No. 11 w 3

Nos. 11 w 3, 11 w 4 and 11 w 5

FOR

FAMILY USE,

HOME MANUFACTURING AND EMBROIDERY

---

The Singer Manufacturing Co.

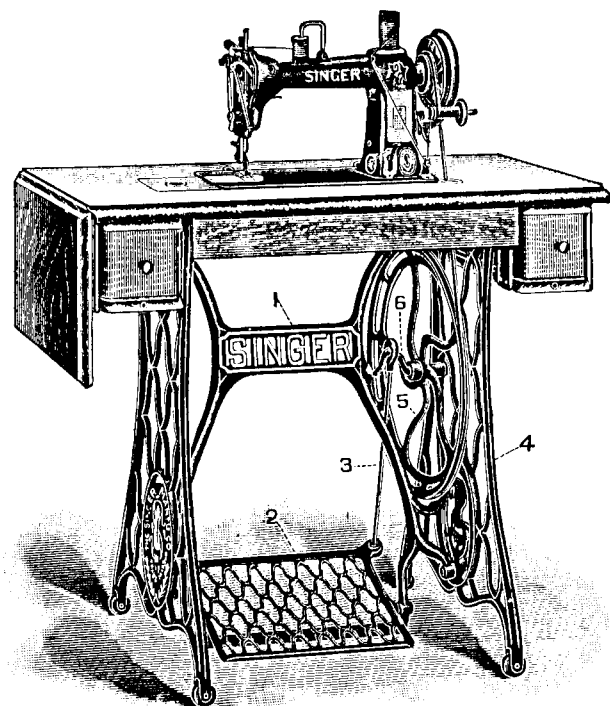

Fig. 3

- 1—Brace.
- 2—Treadle.
- 3—Pitman.
- 4—Leg.
- 5—Band Wheel with two grooves.
- 6—Band Wheel Crank.

The stand must be oiled at each end of the treadle where the pivot screws enter, and at each end of the pitman and band wheel shaft.

If the machine runs hard after standing for some time use a little kerosene or benzine in the oiling places, run the machine rapidly, then wipe clean and oil as before directed. If the machine still runs hard it is certain that some bearing has been overlooked in cleaning and oiling.

## INSTRUCTIONS

### TO OPERATE THE TREADLE

First loosen the stop motion clamping screw outside the balance wheel (24 and 25, see Fig. 2). Then place your feet upon the treadle with the heels back against the rim and the instep over the brace underneath it, turn the balance wheel over **from** you with the right hand, allowing the feet to move freely with the motion thus commenced and continue this motion by an alternate pressure of the heel and toe until a regular and easy movement is obtained.

Do not attempt to sew until you are proficient in the use of the treadle, so that you can start and stop it without turning the balance wheel in the wrong direction. After becoming familiar with the treadle movement, tighten the stop motion clamping screw, raise the presser foot with the lifter, start the balance wheel **over from** you and continue the motion with the feet as above described. After becoming proficient in this motion place a piece of cloth between the feed and presser foot, let down the foot upon it and operate the machine in this way until you have become accustomed to guiding the material.

### THE BELT

The leather belt which gives motion to the machine should always be tight enough not to slip and no tighter; not so tight as to prevent the easy motion of the machine. If the belt is too long, uncouple it and cut off squarely from one end to the desired length; make another hole about  $\frac{1}{4}$  inch from the cut end.

**To Throw Off the Belt.** Turn the band wheel toward you and slip the belt off by pressing it to the right.

**To Throw On the Belt.** The right hand grooves in the wheels are for slow speed, and the left for high. Place the belt in a groove of the balance wheel and let it hang loosely, then press it into a groove of the band wheel.

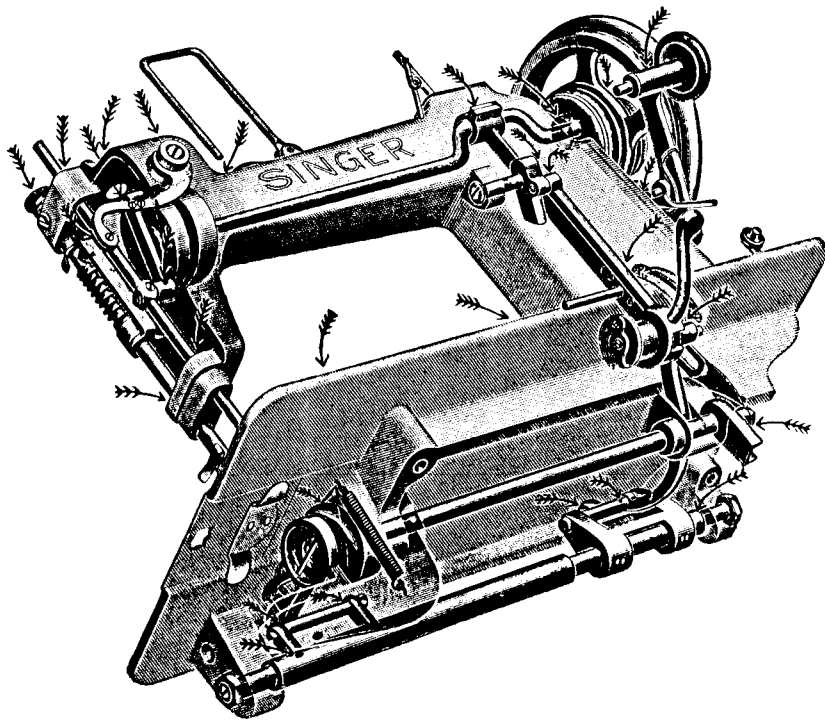

Fig. 4

### TO OIL THE MACHINE

All places where one part of the machine is in movable contact with another require oiling, and oil holes are provided for all bearings which cannot be reached without them. Put a drop of oil in each of the oil holes indicated by arrows in the illustration above. The bobbin winder spindle should be oiled through the oil hole in its arm. Be careful to use no more oil than is needed, a single drop being sufficient at any point.

To remove the face plate loosen screw (11, see Fig. 2) and push the face plate up over the head of the screw.

Do not let the roller in the thread controller at (3) or the roller in the take-up lever at (4, see Fig. 2) become clogged. Oil the stud screws on which they revolve so that they may turn freely.

Never run the machine with the presser foot down except when sewing, as it will scratch the presser foot and dull the feed dog.

### NEEDLES

Needles for Machines Nos. 11 w 3, 11 w 4 and 11 w 5 are of Class and Variety 15 N 17 and are made in sizes suitable for the different sizes of thread commonly used.

The size number of the needle is marked upon its shank.

Orders for needles must specify the quantity required, the size, also the class and variety numbers separated by N.

The following are details of an intelligible order:

"One Doz. No. 14—15 N 17 needles."

### RELATIVE SIZES OF NEEDLES AND THREAD

SIZES OF NEEDLES	CLASS OF WORK TO SEW	SIZE of COTTON LINEN or SILK
9	Very light Fabrics.	200 to 300 Cotton
10	Very thin Muslin, Cambrics, Linens, etc.	100 to 180 Cotton OOO, OO Silk Twist
12	Very fine Calicoes, Linens, Shirtings, fine Silk Goods, etc.	80 to 100 Cotton O Silk Twist
14	Shirtings, Sheetings, Bleached Calicoes, Muslins, Silk and general domestic goods and all classes of general work.	60 to 80 Cotton A. & B. Silk Twist
16	All kinds of heavy Calicoes, light Woolen Goods, heavy Silk, Seaming, Stitching, etc.	50 to 60 Cotton, C Silk Twist
18	Tickings, Woolen Goods, Trousers, Boy's Clothing, Corsets, Cloaks, Mantles, etc.	30 to 50 Cotton D Silk Twist 60 to 80 Linen

To make a smooth, even stitch with your machine, it is necessary to use good, firmly twisted and smoothly finished thread, that passes freely through the eye of the needle; no other needles will give as good results and satisfaction as those recommended above.

Supplies of parts or needles for the machine can be purchased at any Singer Shop, or ordered by mail; money, or a post office order covering their value, including postage should be enclosed with the order, which will then receive immediate attention, be promptly filled and forwarded by mail or express.

### TO SET THE NEEDLE

Turn the balance wheel from you until the needle is at its highest point, loosen the needle set screw, insert the needle in the needle bar with the long groove to the right, push the needle up in the bar as far as it will go, and secure it firmly with the needle set screw. It may be necessary to turn the long groove of the needle slightly toward you if stitches are missed.

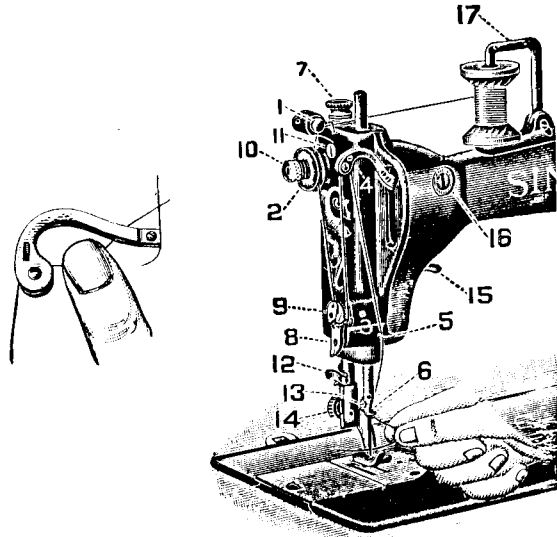

Fig. 5

### TO THREAD THE NEEDLE

Place the spool of thread on the spool holder, pass the thread under the thread retainer guide wire, into thread retainer (1), down in front and **once around** tension pulley (2), thence under thread controller spring (3) and raise the spring until the thread is caught over the projection above the spring, thence up into take-up lever (4), down into thread guide (5) and needle bar thread guide (6), then thread the needle from right to left as shown in Fig. 5, and when the take-up lever is at its highest position draw two or three inches of thread through the eye of the needle, with which to commence sewing. When using fine silk wind it twice around the tension pulley should it slip without turning the pulley.

Do not let thread retainer (1) or tension pulley (2) become clogged with lint, dirt or knots of thread.

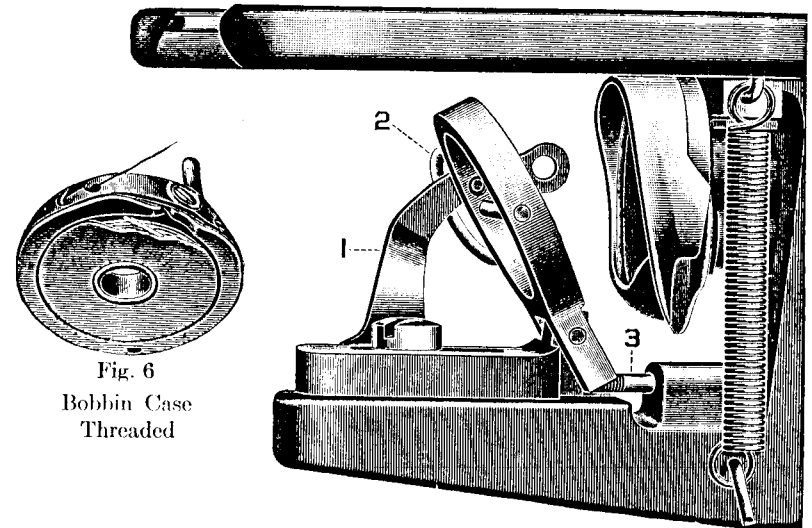

Fig. 6  
Bobbin Case  
Threaded

Fig. 7

### TO REMOVE THE BOBBIN CASE

Draw the slide out from the bed of the machine. Reach down with the thumb and push against spring (1), then with the forefinger draw down drop (2) and lift the bobbin case out, see Fig. 7.

**To Thread the Bobbin Case.** Place the bobbin within the bobbin case so that the thread will draw in the direction indicated in the above cut, then draw the thread into the slot in the edge of the bobbin case and under the tension spring until out through the delivery eye as shown in Fig. 6.

**To Replace the Bobbin Case.** Turn the balance wheel until the needle is at its lowest position, then lay the bobbin case upon the drop with the bobbin next to the hook and push the drop up until secured by the catch.

**Note.** Before inserting the bobbin, the inside of the bobbin case should be wiped with an oiled rag, to remove lint or dirt and to slightly oil the inside of the bobbin case. The hook should also be cleaned.

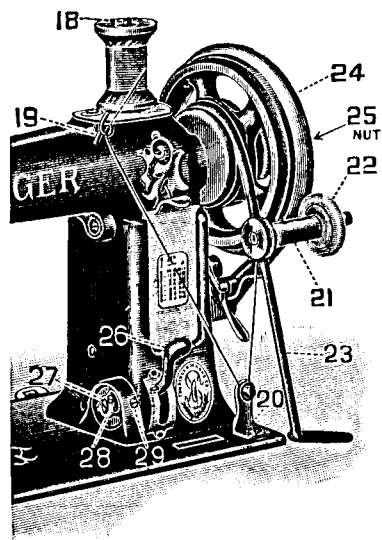

Fig. 8

### TO WIND THE BOBBIN

Loosen the stop motion clamping screw (25) outside of the balance wheel (24). Place the bobbin on the bobbin winder spindle. Put the spool of thread on spool pin (18), draw the free end of the thread into eyelet (19), thence down between the tension discs (20) and up around the bobbin. The free end of the thread must be held by the hand until a few coils are wound and should then be broken off. Fig. 8 shows the bobbin winder properly threaded and in position for winding.

There need be no time lost while winding bobbins as the machine will wind the bobbin while being operated for regular work.

If the bobbin does not fill evenly, move the tension bracket (20) a trifle to the right or left as necessity may require.

**Caution.** Stop winding when the bobbin is nearly full—within three layers of thread from the top edge of the bobbin.

After winding the bobbin push down on the bobbin winder and tighten clamping screw (25) securely.

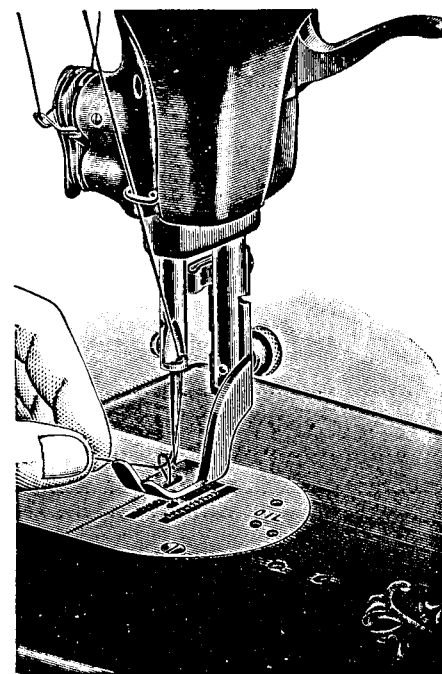

Fig. 9

### TO DRAW UP THE UNDER THREAD

Let the thread extend through the needle two or three inches when the take-up lever is at its highest position. Hold the end of the upper thread slack and turn the balance wheel carefully from you while the needle goes down and up, and its point down to the presser foot (see Fig. 5), bringing the take-up lever to its highest position. Keep your feet on the treadle, as foot pressure on the treadle holds the take-up lever at its highest position, then draw the upper thread and the under thread will come up with it (see Fig. 9). Pass both threads back under the presser foot and up into the thread cutter, which will hold them, thus preventing the accidental unthreading of the needle (See Fig. 10).

**Note.** Form the habit of stopping the machine when the point of the needle gets down to the presser foot when held up by the lifter (see Fig. 5), as the take-up lever is then at its highest position, the tension is released, the work draws out easily, and the needle will not become unthreaded when starting to sew, even if only a short end is left through the needle.

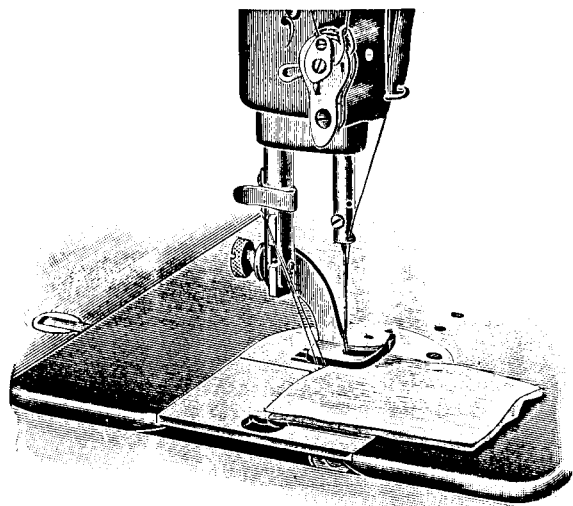

Fig. 10

### TO COMMENCE SEWING

Have both threads passed under the presser foot and drawn up into the thread cutter, as shown in Fig. 10, place the cloth under the presser foot and let down the presser lifter. Start the machine by turning the balance wheel from you. Do not pull or push the work, the machine moves it.

### TO REGULATE THE TENSIONS

The tension on the under thread is regulated by the screw in the center of the bobbin case tension spring, with the small screw driver, turn to the right to increase, or in the opposite direction to diminish the tension. When once properly regulated it will seldom require a change for any kind of thread in common use, as a perfect stitch can usually be obtained by regulating the tension on the upper or needle thread. The upper tension is released and inoperative when the presser bar lifter is raised, and becomes operative when the lifter is lowered; turn the small thumb nut (10, see Fig. 5) in front of the tension spring over toward you to increase the tension or from you to diminish it.

For ordinary stitching the upper and under threads should be locked in the centre of the thickness of the material, thus: 

Fig. 11. Perfect Stitch

If the tension on the upper thread is too tight, or if that on the under thread is too loose, the thread will lie straight along the upper surface of the material, thus: 

Fig. 12. Tight Upper Tension

If the tension on the under thread is too tight, or if that on the upper thread is too loose, the thread will lie straight along the under side of the material, thus: 

Fig. 13. Loose Upper Tension

**Note.** The under tension must not be so loose as to allow the bobbin case to turn with the hook, nor tight enough to require so much tension on the upper thread that it will break or pucker the work. If the under tension becomes too tight while sewing, it is because the bobbin case has caught so much lime or lint from the cloth that the bobbin does not turn freely, and should be cleaned.

### FOR SEWING FLANNEL OR BIAS SEAMS

Use as short a stitch and as light a tension as possible so as to leave the thread loose enough to stand the strain of stretching the goods.

### A STITCH TO RAVEL EASILY

can be had, if desired, by having the upper tension so loose that the under thread will not draw into the goods, but lie straight, as shown in Fig. 13.

### TO ALTER THE LENGTH OF STITCH

When the feed regulating handle (26, see Fig. 8) stands at (o) on the graduated scale, there is no movement of the goods, but as the handle is raised the goods feed forward, or if the handle is lowered below (o) the goods feed backward (toward you) to tack or make fastening off stitches.

The upward movement of the feed regulating handle may be stopped at any position desired, by setting stop (27) for the purpose. Loosen screw (28) and set stop (27) so that the handle cannot be raised above (2) on the graduated scale and retighten screw (28), then, after a few forward stitches are taken, if the handle is pushed down as far as it will go the feed will reverse and move the goods toward you with the same length of stitch as when feeding from you. Other adjustments can be made for other lengths of stitches.

### TO CHANGE THE PRESSURE OF THE PRESSER FOOT ON THE MATERIAL

Turn presser bar thumb screw (7, see Fig. 5) inward to make the pressure heavier or outward to make it lighter; the pressure should be only heavy enough to prevent the material from rising with the needle and to insure the feed moving the work along evenly; a heavier pressure would make the machine run harder and be of no benefit.

### TO TURN A CORNER

Stop the machine while the needle is rising, but before it is out of the material, raise the presser foot and turn the corner, using the needle as a pivot.

### TO REMOVE THE WORK

To remove the work, raise the presser lifter; turn the balance wheel from you until the point of the needle going down reaches the presser foot, bringing the take-up lever to its highest position. Draw the work from you until you can draw the threads into the thread cutter. If the threads do not draw out easily, the needle is not in position, as directed.

### TO REMOVE THE PRESSER FOOT

Raise the presser lifter and remove the presser foot screw (14, see Fig. 2), then draw the presser foot down and out.

### THREAD CONTROLLER

The function of the thread controller spring (3, see Fig. 5), is to hold back the slack of the upper thread until the eye of the needle reaches the goods in its descent.

It may be found advantageous to vary the position of the thread controller spring stop, which has a handle for moving the stop up for less or down for more controller action on the thread.

It may be found necessary to vary the tension of the spring for special requirements.

To vary the tension of the controller spring, loosen the set screw (above 3, see Fig. 5), remove the face plate, then from the inside turn the stud forward or backward as required and tighten the set screw. In any case where an unusually light tension is used, the tension on the controller spring should be correspondingly light. The coils of the controller spring should be oiled occasionally.

**To Place a New Thread Controller in Position.** Remove the entire thread controller by taking out screw (8, see Fig. 2) and release the spring by removing screw (9). (Be careful not to lose the small roller.) Place the new spring, the roller and screw in their positions. Next put the entire thread controller on the face plate, taking care to slide the little tail, on the coil of the spring, into the notch in the stud over which the coil slides.

Oil the small roller occasionally.

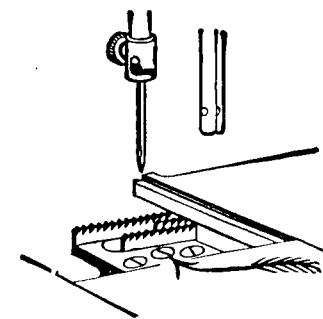

Fig. 14

### TO CLEAN THE FEED

Remove the needle, presser foot and throat plate. Clean all of the parts about the feed bar, hook and bobbin case, and oil all of the parts where there is friction.



### TO RAISE OR LOWER THE FEED DOG

Should the feed dog or feed bar become worn by long use, leaving the points too low, they may be raised by turning the middle screw to the right. (See arrow point in Fig. 14.) Turning the screw to the left will lower them. The points should rise about  $\frac{1}{32}$  inch above the throat plate, or enough to raise the hemmer slightly when it is in the machine.

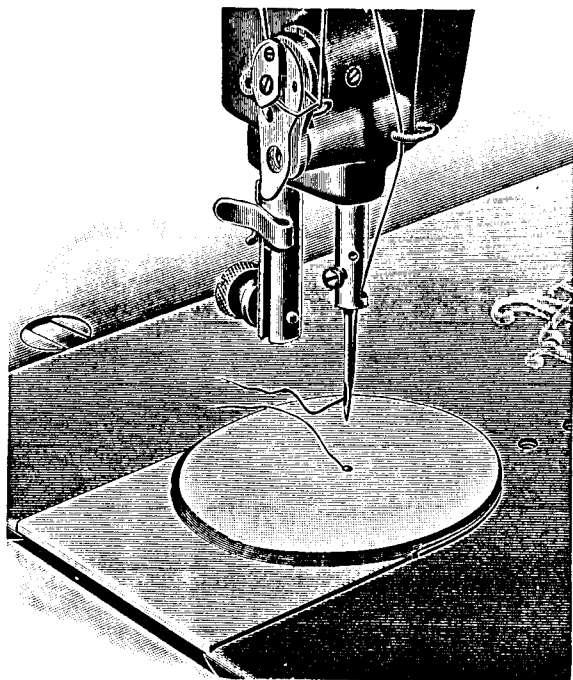

Fig. 15

### THE FEED COVER PLATE

Shown in position for embroidery work.

The feed cover plate slips over the feed dog and its position pin drops into a hole in the bed plate (back). To remove the feed cover plate, tilt or lift its round end slightly and draw it out of the machine.

### TO EMBROIDER

The feed regulating handle (26, see Fig. 2) should stand at (o) on the graduated scale while operating for embroidery.

The fabric with stamped pattern which is to be embroidered should be stretched taut in embroidery hoops and passed under the needle. Some hoops are so thick that it is necessary to hold them in a perpendicular position while passing them under the presser bar and needle. The goods so held are to be moved by the operator from side to side of the pattern while operating the treadle slowly so that a stitch can be taken after each movement of the hoops.

Should some embroidery threads be so thick that they will not pass between the sewing hook and the bar of the bobbin case drop holder, remove the drop holder and turn screw (3, see Fig. 7) slightly outward so that the thread can pass freely and the bobbin case be held in sewing position properly, then tighten the screw firmly which holds the drop holder in position. For fine thread be sure to return screw (3) to its original position.

### INSTRUCTIONS FOR ADJUSTERS

Should the needle bar or hook be moved accidentally, so that the machine will not sew properly, then read the following:

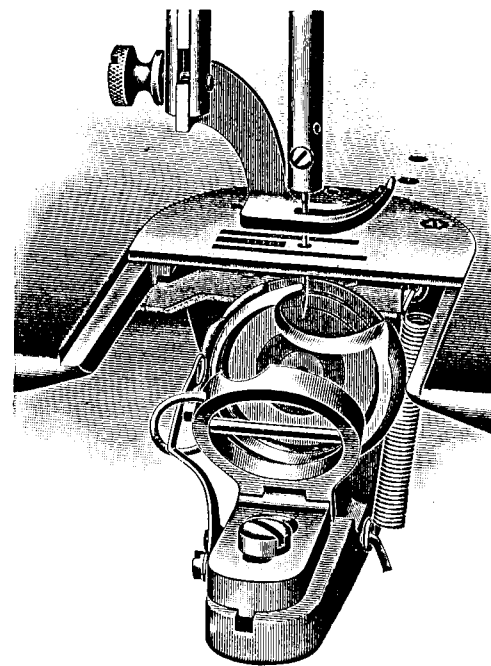

Fig. 16

When the needle is up in the needle bar as far as it will go, and the needle bar is down to its lowest position, the center of the eye of the needle should be in line with the lower mark on the hook washer, if it is not, then adjust the needle bar, up or down, at the needle bar stud.

When the needle is in time and the balance wheel is turned from you until the point of the hook is at the center of the needle, the center of the eye of the needle should be in line with the upper mark on the hook washer. If it is not, bring it into time by adjusting the hook shaft crank on the end of the hook shaft, and see that the hook shaft has no end play after the adjustment is made, as shown in Fig. 16.

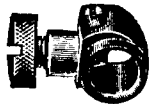

Fig. 17

**NEEDLE BAR THIMBLE**

No. 221756

When the use of the tucker or the ruffler is required, it is necessary to remove the needle set screw and substitute this needle bar thimble. Some operators prefer to leave the thimble on the needle bar for all purposes.

**INSTRUCTIONS**

FOR USING

**A T T A C H M E N T S**

WITH

**Singer Sewing Machine****No. 11 w 3**

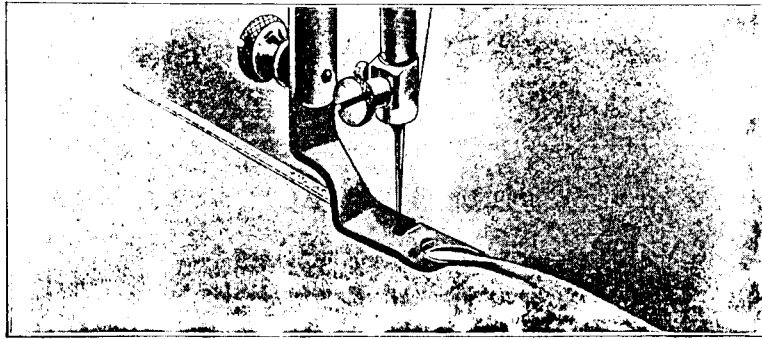

### THE FOOT HEMMER—HEMMING

To hem, clip off the right hand corner, and turn over the cloth about  $\frac{1}{4}$  inch, insert it in the hemmer and draw or push it along until under the needle hole. Let down the hemmer, take two or three stitches and draw gently on the ends of the threads to help the work along until the feed catches it. In guiding, should the edge of the goods begin to run out of the hemmer, move the hand to the right, but if too much cloth turns in, move to the left. In order to have the seam the proper distance from the edge of the hem, the hemmer can be adjusted from right to left by loosening the screw that holds the hemmer in the presser bar. To make what is known as a bag fell, hem the edges of two pieces of fabric together.

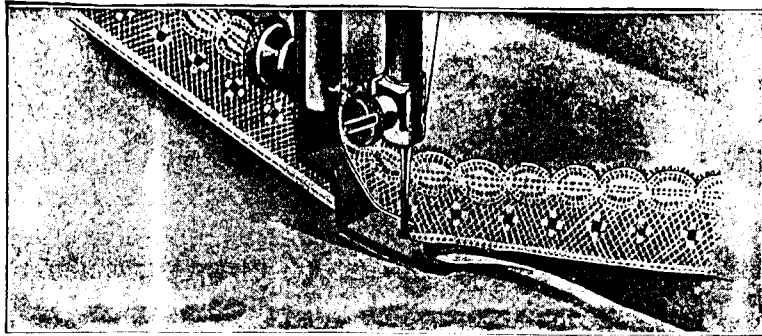

### THE FOOT HEMMER—HEMMING AND SEWING ON LACE

Start the hem as previously explained and when well started, raise the needle to its highest point. Then raise the hemmer and pass the end of the lace down through the slot in the side of the hemmer and under the needle. Care should be taken that the hem is not displaced in the hemmer, and that the needle goes down through the lace and the hem while sewing.

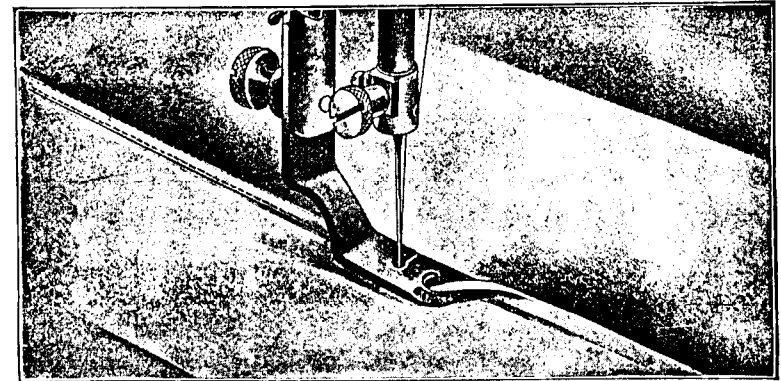

### THE FOOT HEMMER—FELLING

To fell, stitch two pieces of cloth together, with the edges to the right, guide them so that the under piece runs even with the right side of the hemmer and the upper piece so the seam will be about  $\frac{1}{8}$  inch from the edge. When stitched, open the work out flat, the edges standing up straight. Clip off the corners and taking the edges near the starting point in the right hand, and the ends of the threads in the left hand, draw the edges into the hemmer, without disarranging the work. Slightly lengthen the stitch.

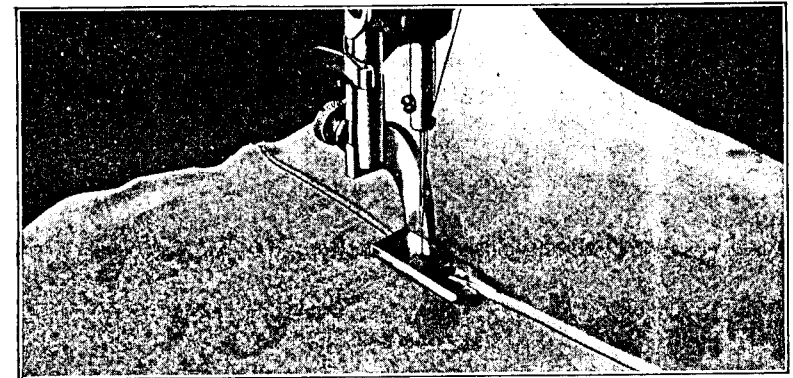

### TO STITCH DOWN BAG FELLS

Use the regular foot hemmer to hem two pieces of cloth together, making a bag fell, then spread them apart, substitute the tongueless feller and insert the hem into the feller, as shown in the cut above, and fell down the hem for a strong seam.

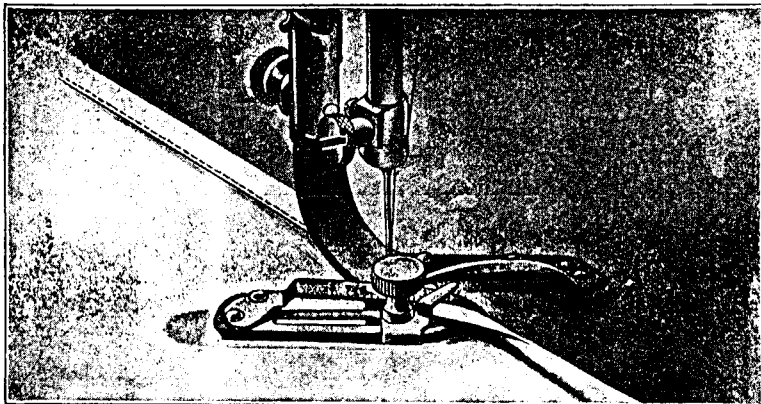

### THE ADJUSTABLE HEMMER—HEMMING

To hem, fold over the right hand corner of the cloth about  $\frac{1}{8}$  inch wide and about one inch long, push the folded end into the scroll of the hemmer and under the needle hole. In guiding, give the hemmer enough cloth, so that the raw edge will turn under. By adjusting the guide in front to the width desired the hemmer will make any width of hem from  $\frac{3}{16}$  to  $\frac{7}{8}$  inch.

Hems can also be made from one inch to three inches or more, by removing the adjustable guide from the hemmer. To make hems above one inch, fold the hem by hand to the width desired, fold the raw edge under about  $\frac{1}{8}$  inch at the starting point, then pass the folded edge into the scroll of the hemmer and under the needle hole.

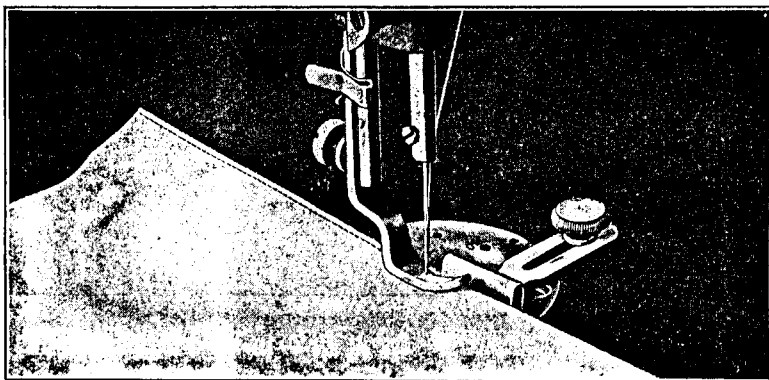

The above illustration shows the presser foot and gauge for close edge stitching in position on the machine, ready to commence sewing.

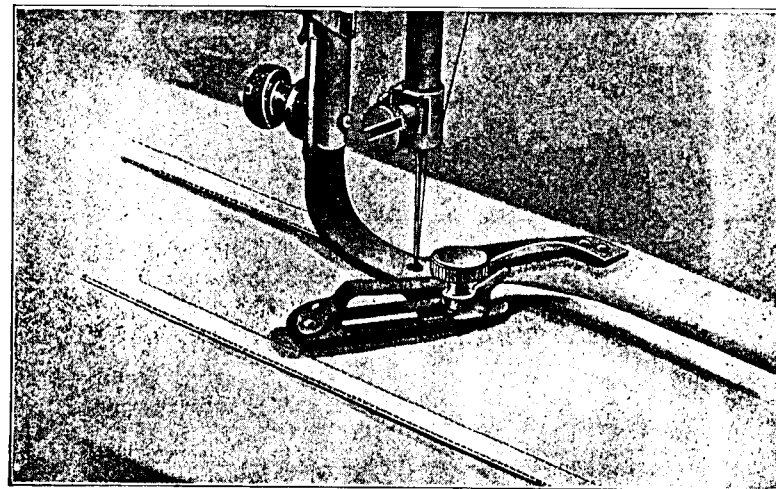

### THE ADJUSTABLE HEMMER—FELLING

To fell, first adjust the guide to width of fell desired. Stitch two pieces of cloth together, guide the under piece even with the outer edge of the adjustable guide and the upper piece so that the seam will be about  $\frac{1}{8}$  inch from the needle. Open the work out flat, the edges standing up, and pass it into the hemmer to fell the seam. This hemmer, being adjustable, will make any width of fell from  $\frac{3}{16}$  to  $\frac{7}{8}$  inch.

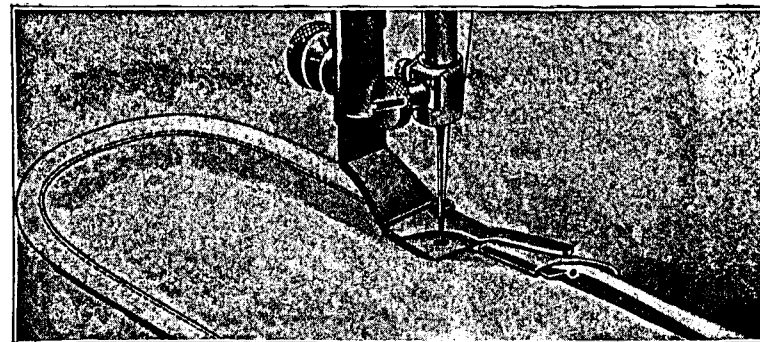

### THE BINDER

To bind, pass the binding through the scroll of the binder and under the needle hole. Place the edge of the goods to be bound between the scrolls of the binder and under the needle hole. Bias binding must be cut  $\frac{7}{8}$  inch wide. Two pieces of cloth may be joined with the binder, thus obtaining a finish on both sides. To bind with Dress Braid pass the braid from

the right, through the slot in the binder and scroll until under the needle hole. The dress braid must be  $\frac{1}{2}$  inch wide.

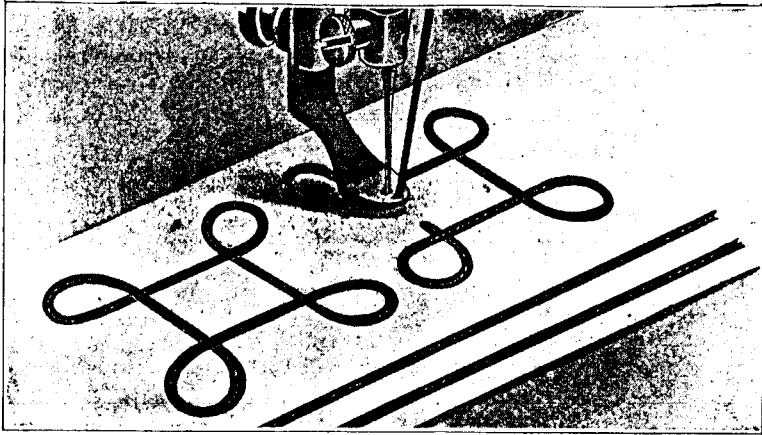

### THE BRAIDER

To braid, place the braid in the upper right hand open drawer of the machine, pass it up and around the arm cap screw at the left of the balance wheel into the guide in front of the needle, down through the braider foot and under the needle hole.

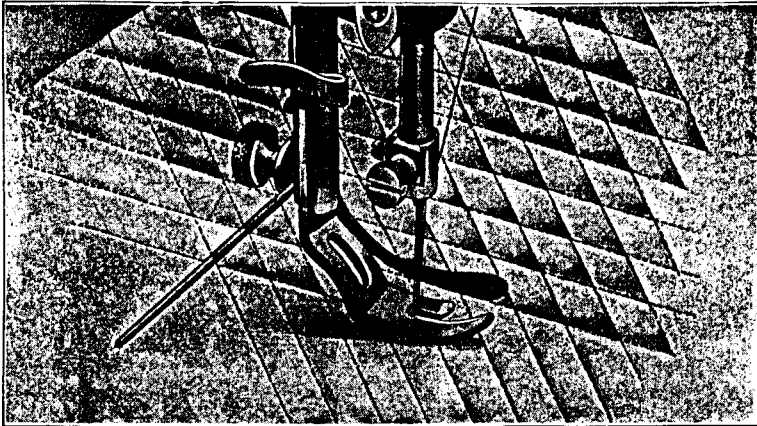

### THE QUILTER

Attach the quilter under the presser foot thumb screw as shown above. To regulate the distance between the rows of stitching, move the quilter as far from the needle as the distance required between the rows, raising the quilter enough to allow the goods to pass freely under it.

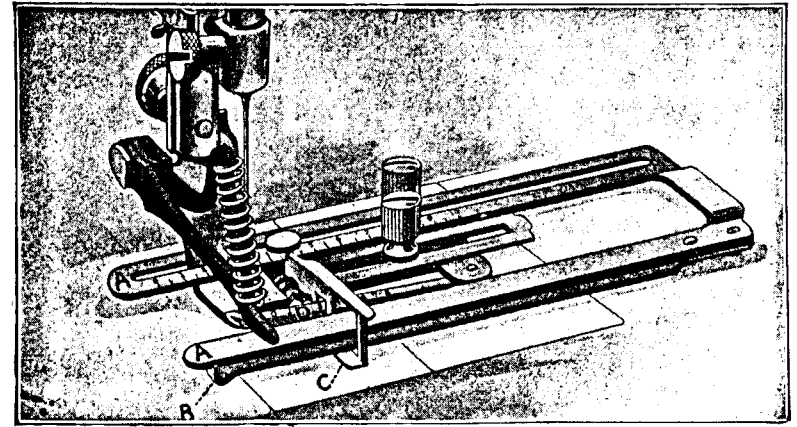

### THE TUCKER

A—Marking Frame. B—Creaser Blade. C—Tuck Guide.  
D—Guard

The width of the tuck is obtained by moving the tuck guide toward or from the needle. The space between the tucks is obtained by moving the marking frame toward or from the needle. To tuck, fold the goods by hand where the first tuck is desired, place the folded edge between marking frame (A) and creaser blade (B), against tuck guide (C), under guard (D) and under the needle hole. While sewing, keep the folded edge against the tuck guide. For the next and following tucks, fold the fabric where it is creased. Place the work in the tucker with the tucks underneath as shown below.

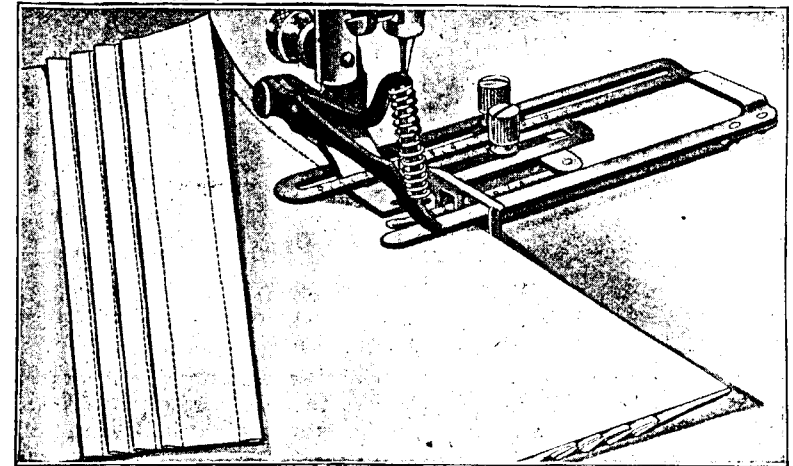

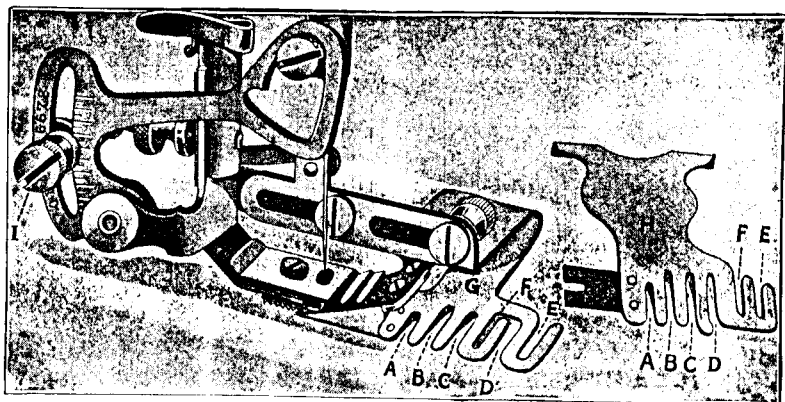

### TO ATTACH THE RUFFLER ON THE MACHINE

Raise the needle to its highest point. Hold the ruffler in the left hand and pass it to the right until the needle is over the needle hole. Swing the ruffler around into the slot of the presser bar, with the operating lever loop over the needle set screw, let down the presser lifter and then fasten the ruffler in the presser bar by tightening the thumb screw firmly with the screw driver.

The shirring plate (H) is used for shirring and for ruffling where more room is required than can be obtained with ruffler guide (G). To use the shirring plate remove the ruffler guide and place the shirring plate under the ruffler, screw it to the bed of the machine at the right of the needle.

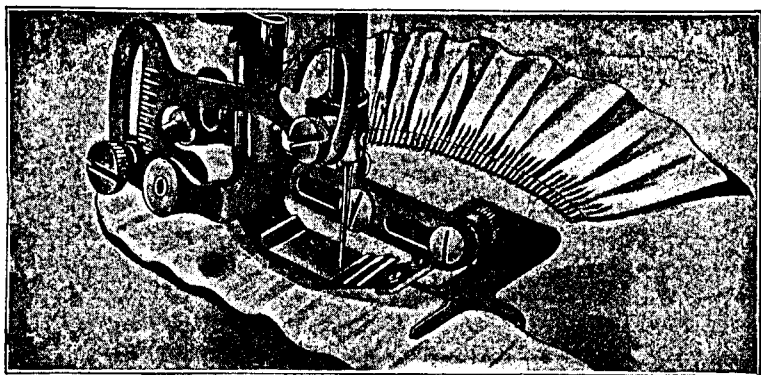

### PLAIN RUFFLING

Pass the edge of the cloth to be ruffled, down through slot (C) up through slot (B) and between the crimping and guide blades. The fullness of the ruffle is regulated by adjusting thumb screw (I). Raise it to make full and lower it to make scant ruffles. The fineness is governed by length of stitch, as in ordinary sewing.

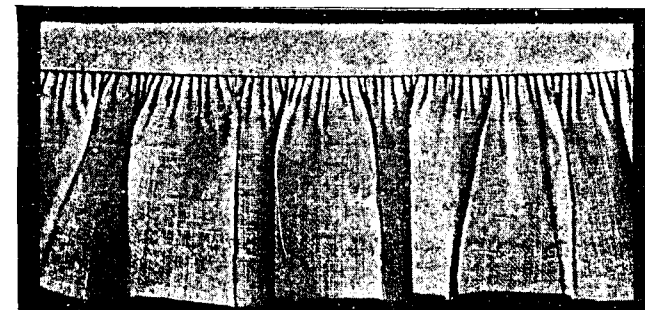

### RUFFLING AND SEWING ON FOR A BLIND STITCHED BAND ON THE RUFFLE

Guide the edge of the cloth down through slot (D, see page 26) and under the ruffler. Pass the strip to be ruffled down through slot (C) and up through slot (B), between the crimping and guide blades. When sewed turn the ruffle back.

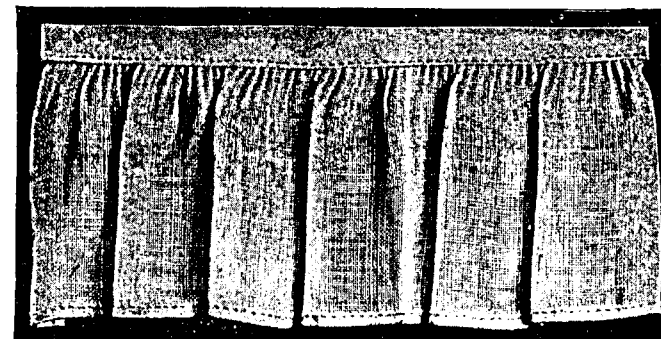

### RUFFLING AND SEWING ON FOR AN EDGE STITCHED BAND ON THE RUFFLE

Insert the edge of the strip to be ruffled from the right down through slot (D) and up through slot (F, see page 26) if not too wide for guide (G). If too wide, use shirring plate (H) in place of the guide, inserting the strip up through slot (F) and between the crimping and guide blades. Fold the edge of the band under, about  $\frac{1}{4}$  inch, and insert, with the folded edge under, from the top through the slot nearest the needle hole in the ruffler foot.



### RUFFLING BETWEEN TWO PIECES OF CLOTH

Fold the edge of the under band over and the edge of the upper band under. The under band with the folded edge up should be passed up through slot (B, see page 26) and down through slot (A) under the ruffler. Insert the strip to be ruffled from the right down through slot (D) up through slot (F) and between the crimping and guide blades. Place the upper band with the folded edge under, through the slot nearest the needle hole in the ruffler foot.

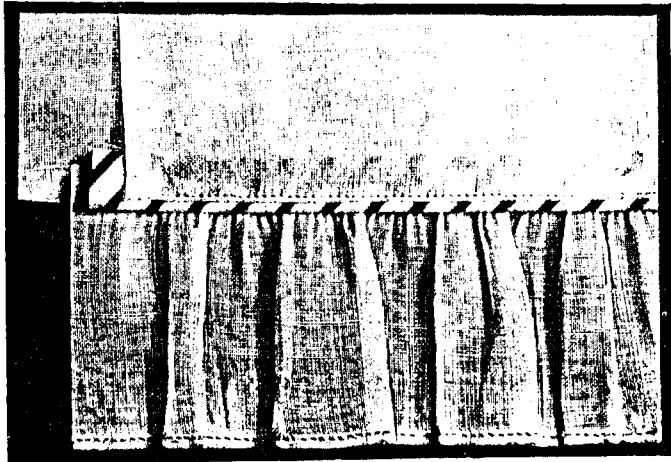

### RUFFLING BETWEEN TWO PIECES OF CLOTH WITH PIPING INSERTED

Proceed in the same manner as directed above.

Before placing the upper band in position insert the piping through the second slot from the needle hole in the ruffler foot. Then insert the upper band as directed.

### TO EDGE STITCH A RUFFLE ON CLOTH

Place the cloth under the entire ruffler. Turn the edge of the ruffle under by hand about  $\frac{1}{4}$  inch, pass the folded edge down through slot (D, see page 26), up through slot (A) and between the crimping and guide blades.

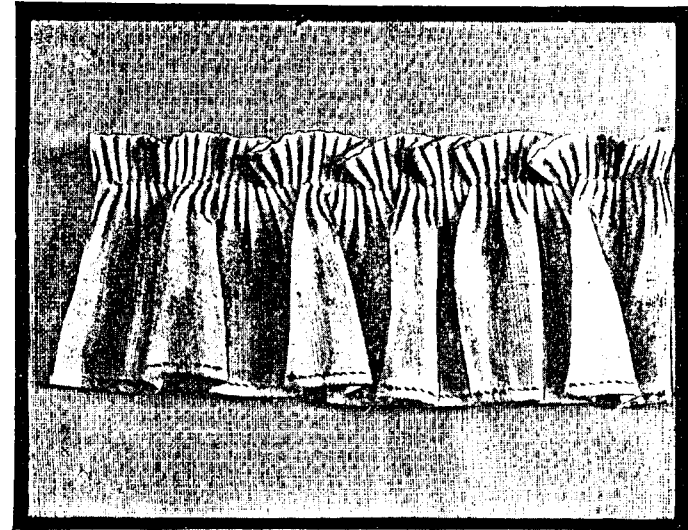

### TO STITCH A RUFFLE ON CLOTH WITH A HEADING

Place the cloth under the entire ruffler. Turn the edge of the ruffle under by hand about  $\frac{3}{8}$  inch, pass the folded edge down through slot (D, see page 26), up through slot (B) and between the crimping and guide blades.

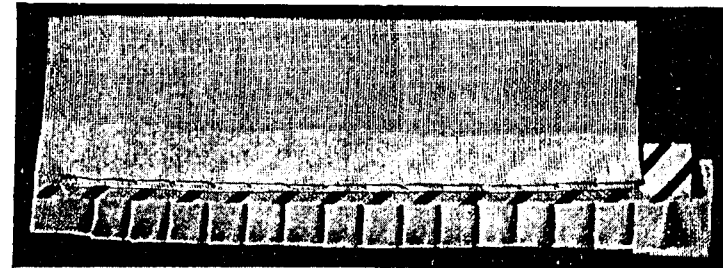

### TO PLAIT WITH THE RUFFLER AND INSERT PIPING

Pass the folded strip down through slot (D, see page 26) up through slot (B) and between the crimping and guide blades. The piping is passed down through the second slot from the needle hole in the ruffler foot. Fold the edge of the top band under about  $\frac{1}{4}$  inch and pass it down through the first slot from the needle hole in the ruffler foot. This work requires a long stitch.

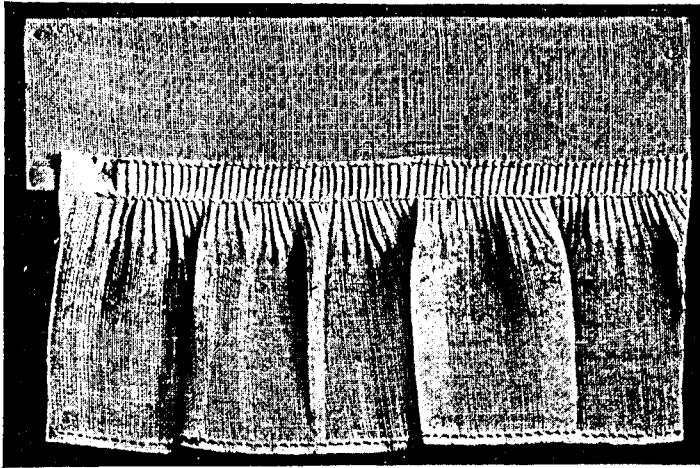

#### TO SEW A FINISHED RUFFLE ON THE EDGE OF MATERIAL FOR WINDOW DRAPERY, ETC.

Fold the edge of the material under about  $\frac{1}{4}$  inch where the ruffle is desired, pass it with the folded edge down, up through slot (B, see page 26) and down through slot (A). In starting be sure that the needle passes through the under piece. The ruffle is also folded under about  $\frac{1}{4}$  inch. Guide the ruffle down through slot (D) and up through slot (C) and between the crimping and guide blades. When stitched flatten out the material and ruffle, remove the ruffler from the machine, place the regular presser foot in its place, and sew down the top of the ruffle.

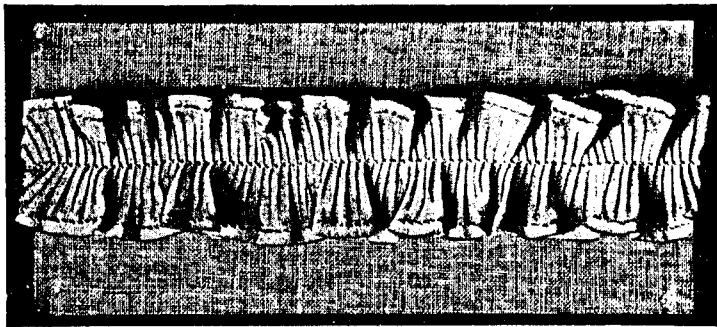

To produce the result shown above, place the cloth under the entire ruffler and guide the strip to be ruffled so that the seam will be in the middle.

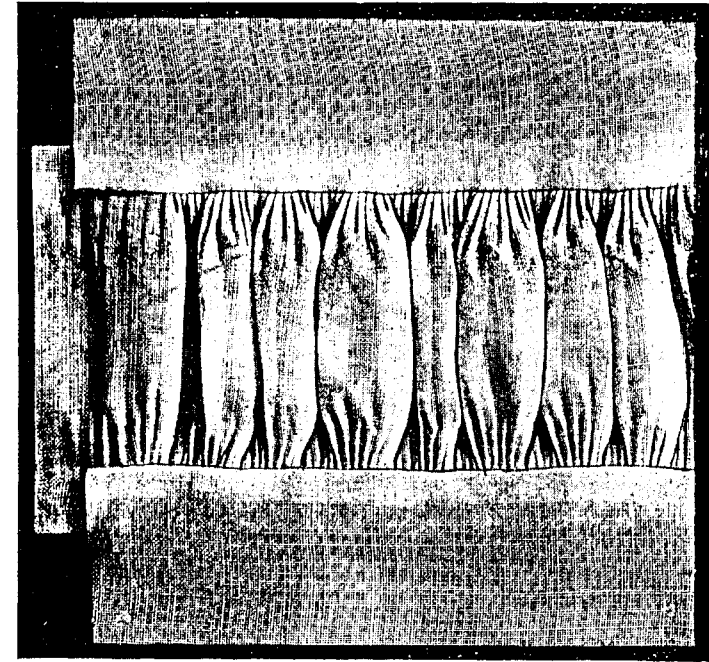

#### RUFFLING (OR PUFFING) BETWEEN TWO PIECES OF CLOTH

Pass the cloth down through slot (D, see page 26) and under the ruffler. The ruffling is passed down through slot (C) up through slot (B) and between the crimping and guide blades. When one side is done, turn the work end for end and do the other side. In doing the opposite or second seam, be careful to have the fullness equal to the first.

With ruffler guide (G) a ruffle can be made up to  $2\frac{1}{2}$  inches wide. If a wider ruffle is desired attach the shirring plate as directed on page 26.



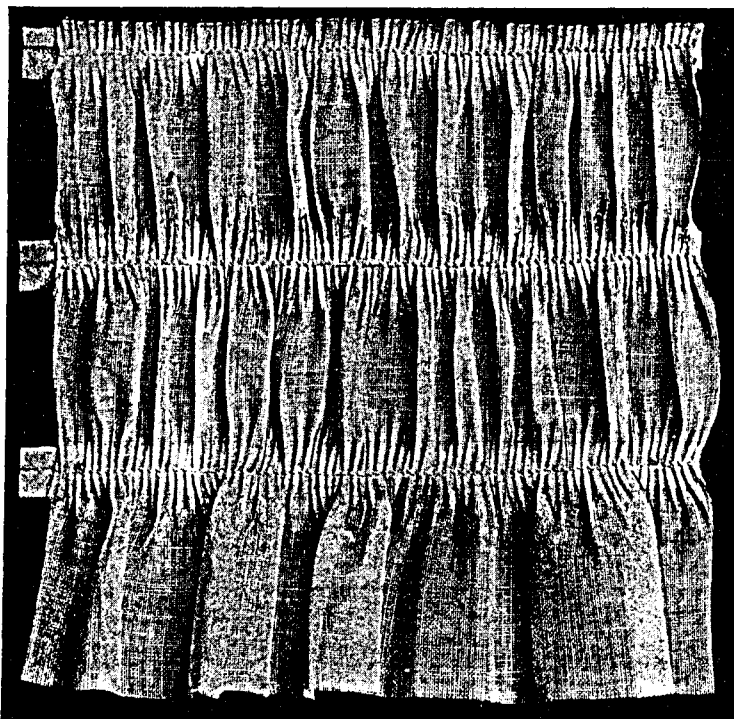

### SHIRRING WITH THE RUFFLER AND SHIRRING PLATE

Remove guide (G, see page 26) from the ruffler and screw shirring plate (H) to the bed of the machine at the right of the needle. In shirring, place the cloth over the shirring plate, and under the ruffler. The quilter may be used as a guide. (See page 26.)

### RUFFLING STITCHED UPON A BRAID OR STRIP TO ADD STRENGTH

Remove guide (G, see page 26) from the ruffler, and screw shirring plate (H) to the bed of the machine at the right of the needle. The braid or strip is passed up through slot (F) down through slot (B) and under the shirring plate. Place the cloth to be shirred over the shirring plate and under the ruffler.