

PFAFF

9371-SPS

Instruction Manual

This Manual is a Description of the Operation Method and Other Details Having to do With the Operation for the Proper Use of the SPS/A (SPS/B) Series Electronically Controlled Bartacking /Button Sewing Machine. Please Read the Manual Thoroughly Before Operation.



■ Don't use in case of power voltage is 380V in European area.

1. The safety regulations in this manual are indicated as DANGER, WARNING, and CAUTION. They indicate that ignorance of the rules may bring injures, physical damages, or machine breakdown.
2. Please don't use this machine for other uses and ways that are not described in this manual. We don't take responsibility for machine damage and physical injury due to the ignorance of the rules.
3. Part of the content might be different from reality due to change for functional improvement of the product.

PFAFF Industrie Maschinen AG

Postfach 3020

D-67653 Kaiserslautern

Königstr. 154

D-67655 Kaiserslautern

Organization of the BARTACK S/M MODEL

1) Electronic Presser Foot Rising Device Attached Type

9371-SPS / A - B 1 2 0 1 - H

① Pattern System

② Series Classification
A: Belt Type
B: Direct Motor Type

③ Bartack Sewing Machine

④ Material Type

H : For Heavy weight Materials
M : For normal Materials
L : For Thin Materials
K : For Kint

2) Pneumatic Presser Foot Rising Device Attached Type

9371-SPS / A - B 1 2 0 1 HA -

① Pattern System

② Series Classification
A: Belt Type
B: Direct Motor type

③ Bartack Sewing Machine

④ Pneumatic Presser Foot Rising Device

⑤ Classification of Presser Foot Driving Mode
20: Serial type of presser foot driving
22: Separate type of presser foot driving

⑥ Classification of Option
W: Electronic wiper attached type
TH: Upper thread holding device attached type

BUTTON S/M MODEL

9371-SPS / B - B 1 2 0 2 - 0 1

① Pattern
System

② Series
A: Belt Drive Type
B: Direct Drive Type

④ Button Type
01 : Small-Size Button
(Mechanical Type Wiper)
02: Large-Size Button
(Mechanical Type Wiper)
03 : Small & Large Size Button
(Solenoid Type Wiper)

③ Button S/M Model Name

Instruction Manual

Section 1

Contents

.....

1. Machine safety regulations	6
2. Machine Specifications	9
3. Machine Structure	10
1) Names of each part of the machine	10
2) Inside structure of control box	11
4. Machine Installmant	12
1) Machine installment conditions	12
2) Electric installment conditions	12
3) How to safely install the table	12
4) Connection of Connector	14
5) The assembly of peripheral parts	15
6) Installation Method of Air Pressure Specifications(HA type)	16
7) Mounting Option Wiper and Adjusting Method(HY Type)	19
8) Connecting the power code	23
9) Changing the voltage	23
5. Preparations before operating the machine	24
1) How to supply oil	24
2) How to install the needle bar	25
3) How to thread the upper thread	26
4) Threading the lower thread	26
5) How to take bobbin case on and off	26
6) How to adjust the tension of the upper thread and the lower thread	27
7) How to wind the lower thread	27
8) How to operate a pedal	28
9) Pedal Operation Method(for HA Type)	28
10) Disposing the waste oil	28
11) Compressed air input and air pressure adjusting method(HA Type)	29
12) Adjusting method of upper thread holding device (Option)	29

6. How to repair the machine	30
1) Adjusting the height of needle bar	30
2) Adjusting the needle and shuttle	30
3) Adjusting the lower shaft gear and rocking shaft gear	31
4) Adjusting the position of shuttle upper spring	31
5) Adjusting the height of work clamp foot	32
6) Adjusting the parts of thread release	32
7) Adjusting the parts of wiper	34
8) Adjusting the parts for trimming	34
9) Adjusting the devices for main thread adjustment	37
10) Adjusting the winder devices	37
11) Setting up the synchro position	37
12) Setting up the X-Y origin	38
13) Cleaning the filter	39
14) Exchanging the fuse	39
7. Cause of Breakdown and Troubleshooting	40
8. Pattern List	42
9. Drawing of Table	43
10. Gauge List	44
11. Option List	45
12. Pneumatic Diagram	47
1) SPS/A-B1201HA-20 Air System Circuit Diagram	47
2) SPS/A-B1201HA-22 Air System Circuit Diagram	48



MACHINE SAFETY REGULATIONS

Safety instruction on this manual are defined as Danger, Warning and Notice.
 If you do not keep the instructions, physical injury on the human body and machine damage might be occurred.

Danger : This indication should be observed definitely. If not, danger could be happen during the installation, conveyance and maintenance of machines.

Warning : When you keep this indication, injury from the machine can be prevented.

Notice : When you keep this indication, error on the machine can be prevented.

<p>1-1)Machine Transportation</p> 	<p>Those in charge of transporting the machine should know the safety regulations very well. The following indications should be followed when the machine is being transported.</p> <ul style="list-style-type: none"> Ⓐ More than 2 people must transport the machine. Ⓑ To prevent accidents from occurring during transportation, wipe off the oil on the machine well.
<p>1-2)Machine Installation</p> 	<p>The machine may not work well or breakdown if installed in certain places, Install the machine where the following qualifications agree.</p> <ul style="list-style-type: none"> Ⓐ Remove the package and wrappings starting from the top. Take special notice on the nails on the wooden boxes. Ⓑ Dust and moisture stains and rusts the machine. Install an airconditioner and clean the machine regularly. Ⓒ Keep the machine out of the sun. Ⓓ Leave sufficient space of more than 50cm behind, and on the right and left side of the machine for repairing. Ⓔ EXPLOSION HAZARDS Do not operate in explosive atmospheres. To avoid explosion, do not operate this machine in an explosive atmosphere including a place where large quantities of aerosol spray product are being used or where oxygen is being administered unless it has been specifically certified for such operation. Ⓕ The machine were not provided with a local lighting due to the feature of machine. Therefore the illumination of the working area must be fulfilled by end user. <p>[Refer] Details for machine installment are described in 4. Machine Installment.</p>
<p>1-3)Machine Repair</p> 	<p>When the machine needs to be repaired, only the assigned troubleshooting engineer educated at the company should take charge.</p> <ul style="list-style-type: none"> Ⓐ Before cleaning or repairing the machine, close down the motive power and wait 4 minutes till the machine is completely out of power. Ⓑ Not any of the machine specifications or parts should be changed without consulting the company. Such changes may make the operation dangerous. Ⓒ Spare parts produced by the company should only be used for replacements. Ⓓ Put all the safety covers back on after the machine has been repaired.

1-4) Machine Operation



Warning

SPS/A-B1201 Series is made to sew patterns on fabrics and other similar material for manufacturing.

Follow the following indications when operating the machine.

- Ⓐ Read through this manual carefully and completely before operating the machine.
- Ⓑ Wear the proper clothes for work.
- Ⓒ Keep hands or other parts of the body away from the machine operation parts (needle, shuttle, thread take-up lever, and pulley etc.) when the machine is being operated.
- Ⓓ Keep the covers and safety plates on the machine during operation.
- Ⓔ Be sure to connect the earthing conductor.
- Ⓕ Close down the electric motive power and check if the switch is turned "off" before opening electric boxes such as the control box.
- Ⓖ Stop the machine before threading the needle or checking after work.
- Ⓗ Do not step on the pedal when turning the power on.
- Ⓘ Be sure to connect the earthing conductor.
- ⓫ If possible, install the machine away from loud noises such as high frequency welding machines

[Warning]

Belt will crush or amputate finger or hand, keep cover in place before operating, turn off power before inspecting or adjusting.

1-5) Caution Mark Position



Do not operate without finger guard and safety devices. Before threading, changing bobbin and needle, cleaning etc., switch off main switch on.



Hazardous voltage will cause injury. Turn off main switch and unplug power cord before opening this cover.

Caution mark is attached on the machine for safety.

When you operate the machine, observe the directions on the mark.

Position of Warning Mark

[View from the right-front]

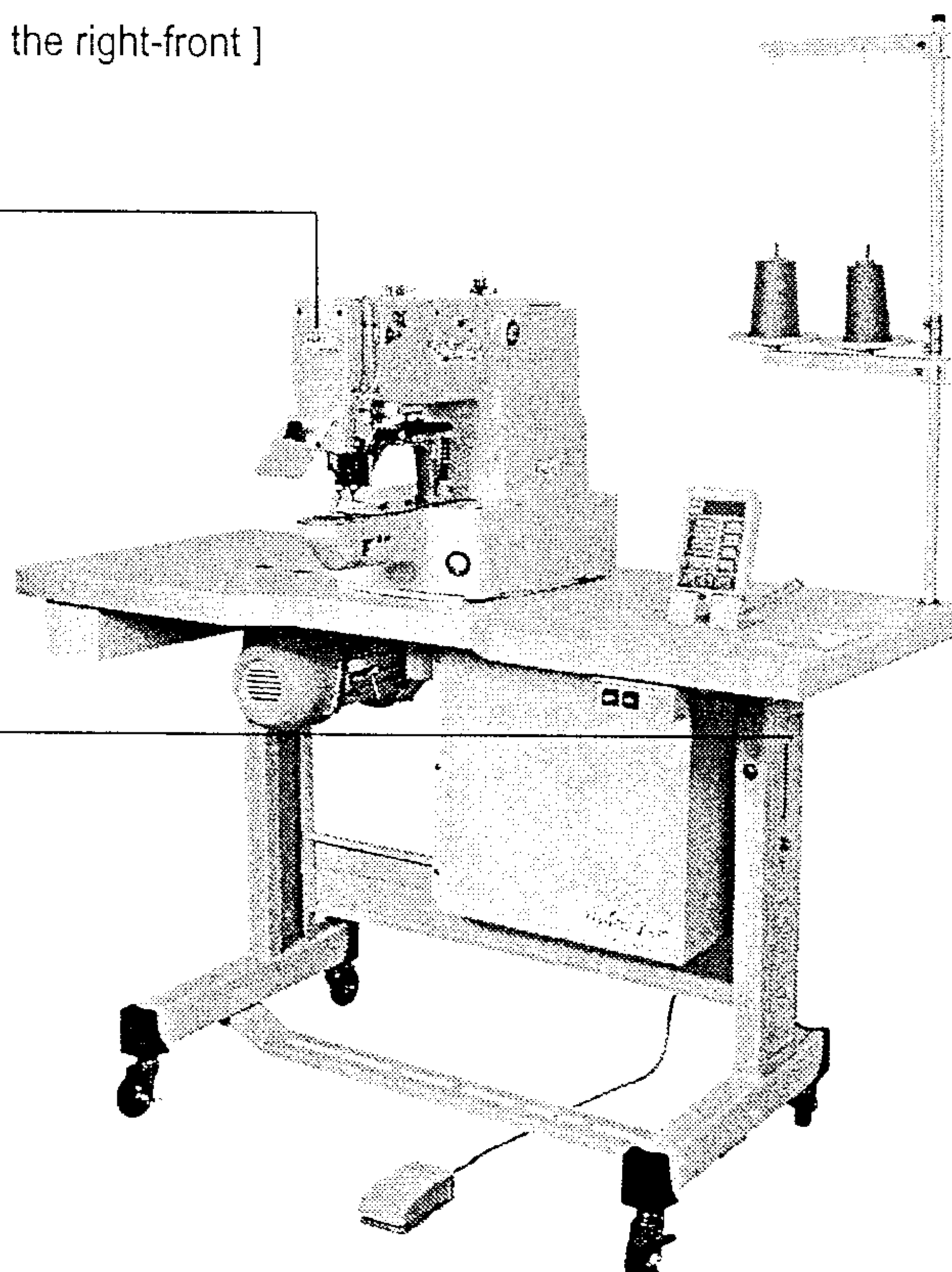



1-6) Contents of Marks





Caution

1)

 CAUTION 

Do not operate without finger guard and safety devices. Before threading, changing bobbin and needle, cleaning etc., switch off main switch on.

2)

 CAUTION 

Hazardous voltage will cause injury. Turn off main switch and unplug power cord before opening this cover.

2

MACHINE SPECIFICATIONS

Name of model	SPS/A-B1201HA	SPS/A-B1201H	SPS/A-B1201 M	SPS/A-B1201 L	SPS/A-B1201 K
Sewing area	X : 40mm Y : 20mm				
Maximum Sewing speed	Max. 2,200spm	Max. 2,700spm		Max. 2,000spm	
Stitch Length	0.1~10mm				
Feeding system	Feeding by Stepping Pulse Motor				
Needle bar Stroke	41.2mm				
Needle	DP×17 #23	DP×17 #19	DP×5 #16	DP×5 #11	
Height of work clamp foot	Max. 20mm	Max. 17mm			
Input Available Stitch	Max. 10,000 stitches				
Input Available Pattern No.	Max. 99 patterns (Standard: 32Patterns)				
Shuttle	Standard Shuttle Hook				
Memory	P-ROM				
Enlargement/ Reduction	20% ~ 200%				
Max. Speed Limit	Adjustment of speed limit is available from 100~2,700 spm by outer switch				
Pattern Selection	Selection of pattern number is available from 1~99.				
Main Motor	550W AC Servo Motor				
Consumption Power	600VA				
Proper Temperature of machine running	5°C ~ 40°C				
Proper Humidity of machine running	20% ~ 80%				
Voltage	1φ 100~240V, 3φ 200~440V, 50/60HZ				
	0.49Mpa (5kgf/cm ²)				
Airborne noise level	L = 78.8LAeq				

※ Remark : The Airborne Noise Level given above was measured in accordance with the prEN/ISO10821 with the respective machine operating at maximum speed without any material being positioned.

MACHINE STRUCTURE

1) Names of each part of the machine

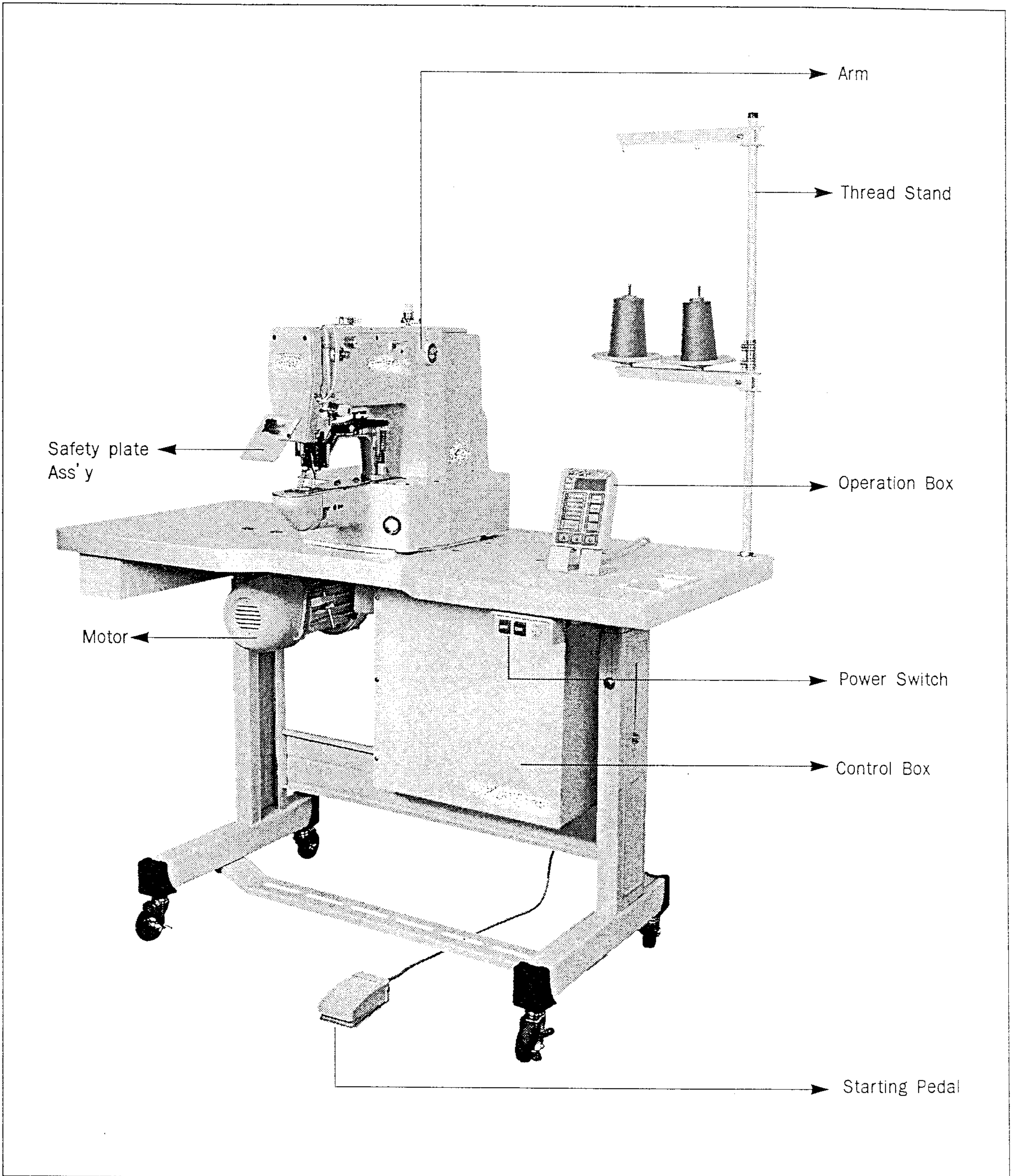

2) Inside structure of control box

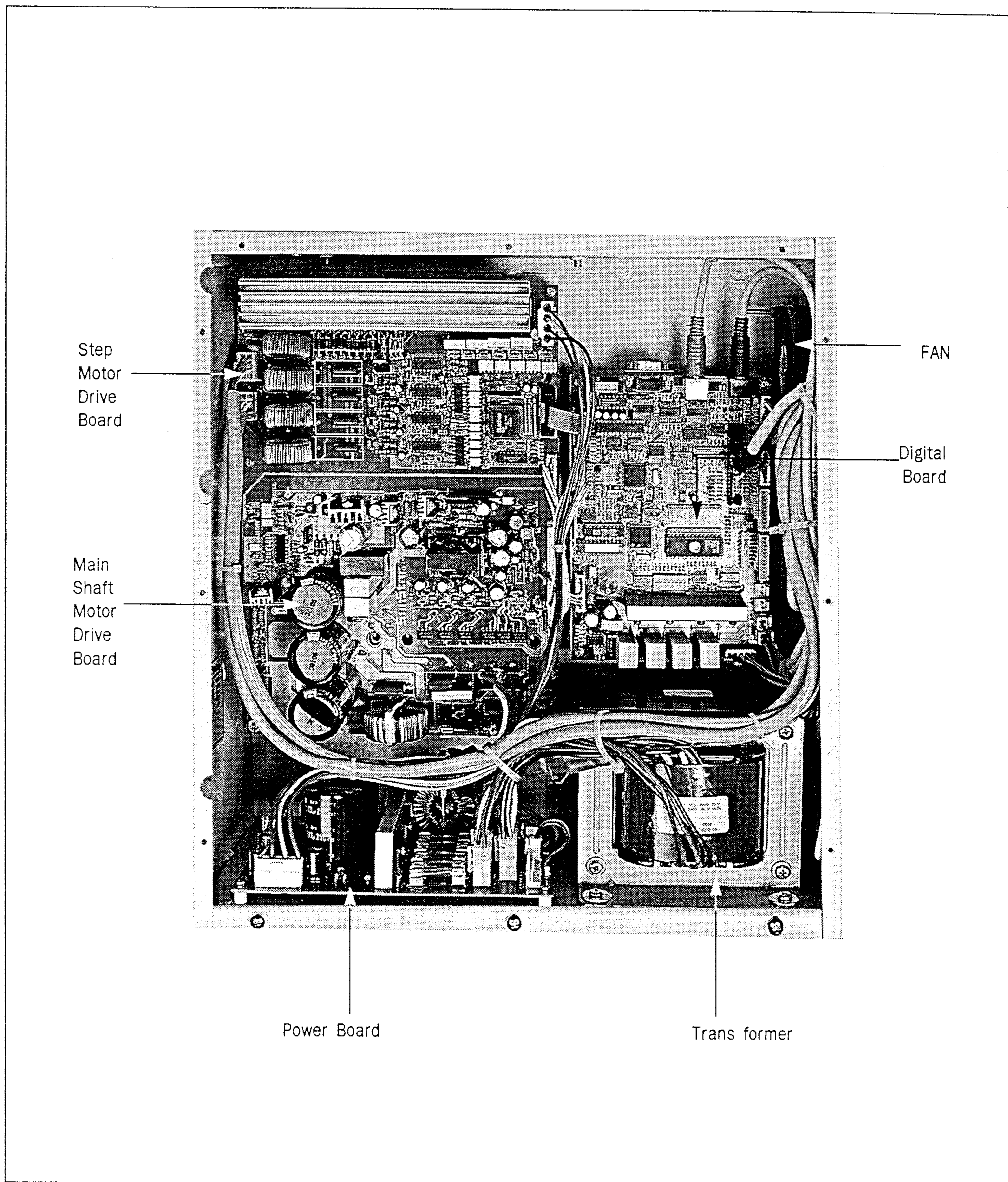

4

MACHINE INSTALLMENT

1) Machine installment conditions

- A. Do not use the machine where the voltage is over regular voltage $\pm 10\%$ to prevent accidents.
- B. For safe operation of the machine, use the machine under the following conditions.
 - ☐ Surrounding Temperature During Operation : $5^{\circ}\text{C} \sim 40^{\circ}\text{C}$
 - ☐ Surrounding Temperature During Maintenance : $-10^{\circ}\text{C} \sim 60^{\circ}\text{C}$
- C. Humidity : Between 20~80%(Relative humidity)

2) Electric installment conditions

- A. Power Voltage
 - The power voltage must be between regular voltage $\pm 10\%$.
 - The frequency of the power should be regular frequency (50/60HZ) $\pm 1\%$.
- B. Electromagnetic Wave Noise
 - Use separate power with strong magnetics or high frequency products, and do not leave the machine near them.
- C. Use low voltage when supplements or accessories are being adhered.
- D. Be careful not to have water or coffee be spilled into the Controller and Motor.
- E. Do not drop the Controller or Motor.

3) How to safely install the table

- A. Fix the oil tub holder ①, oil holder ②, control box ③, main switch ④ and motor ⑤ on the table.

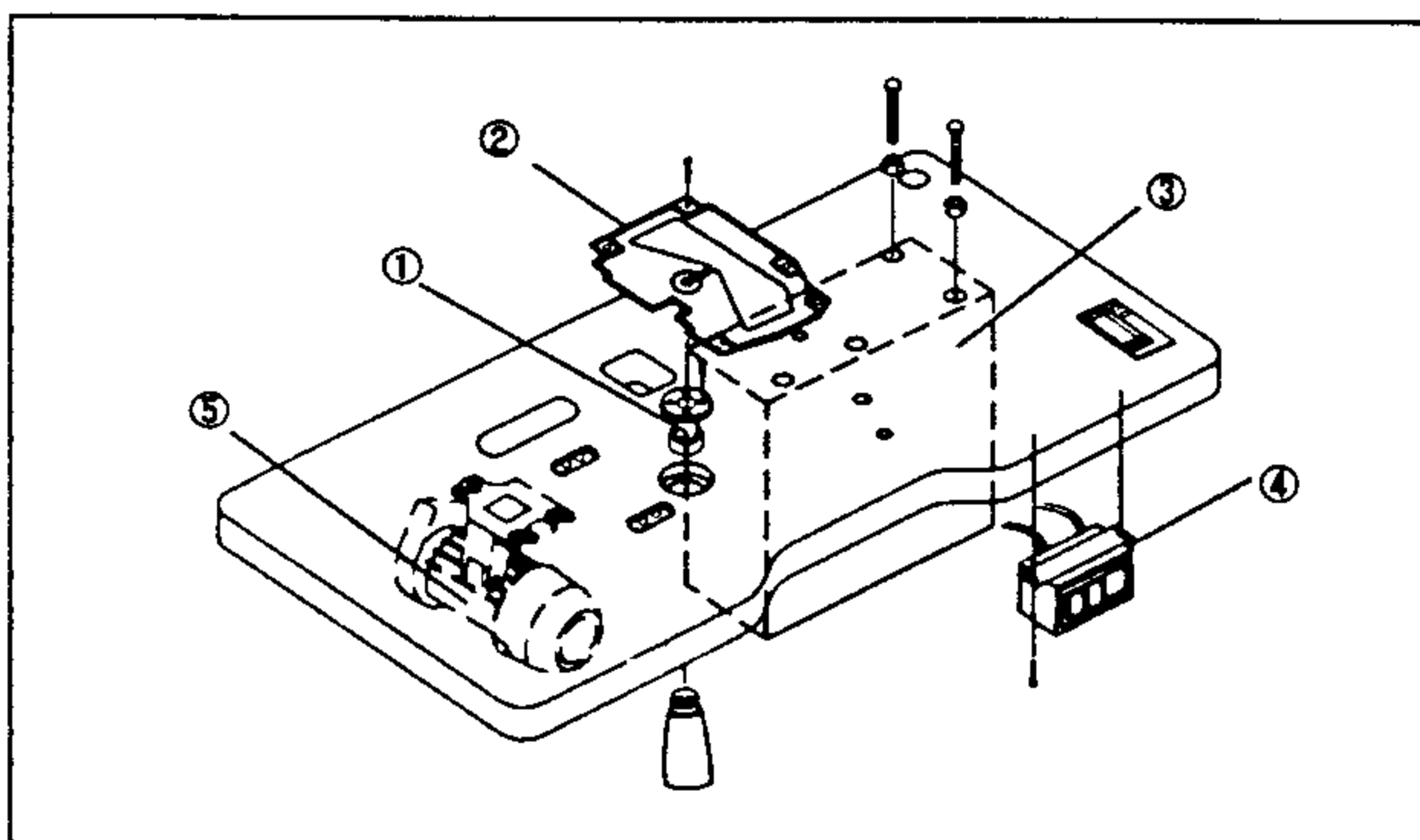

[Fig. 1]

- B. Attach the bed cushion rubber to the table.

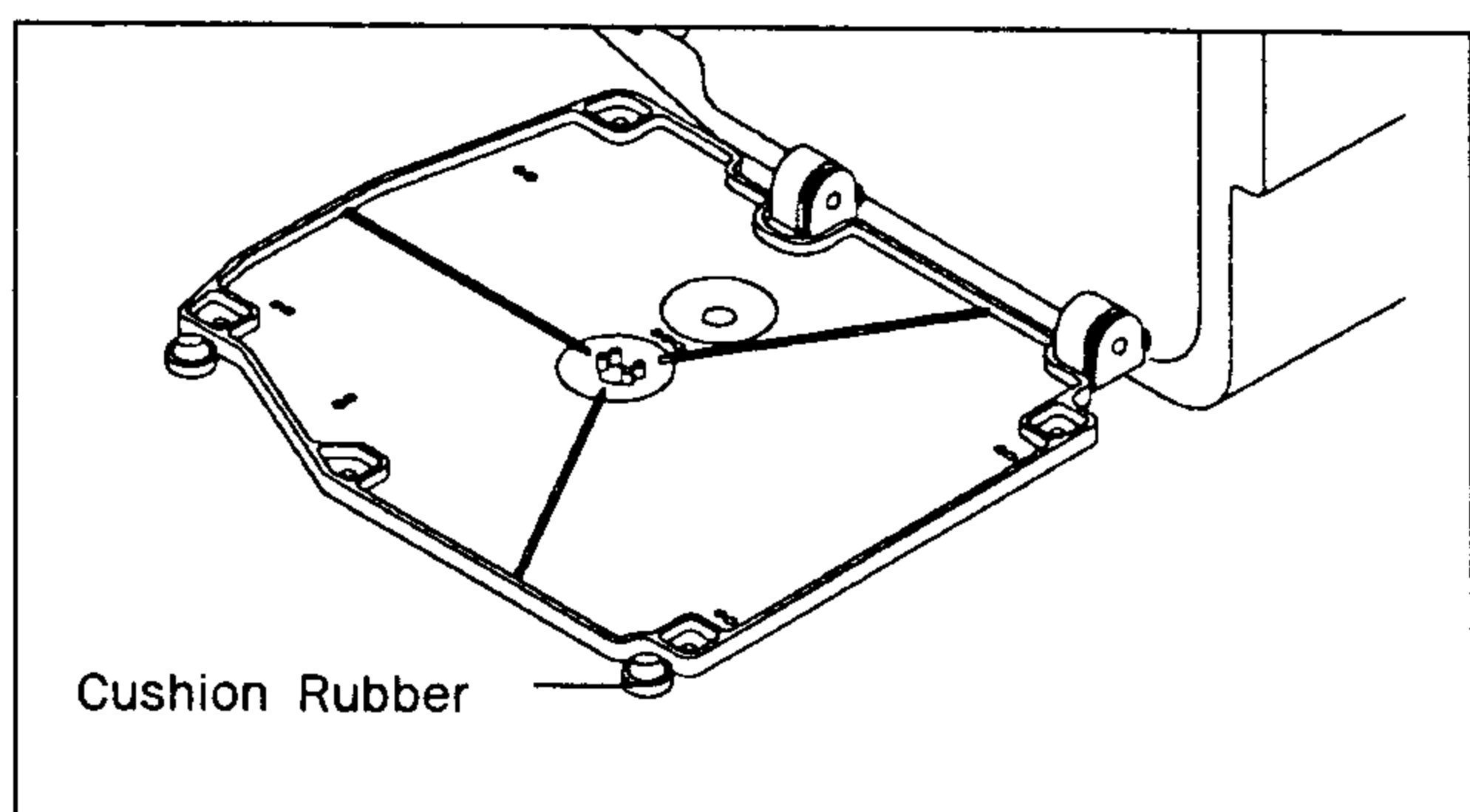

[Fig. 2]

- C. Add the hinge metal and hinge rubber to the bed. Then insert the fixing bolt into the hinge metal hole of point ① and fix the table as shown in the picture.

[Danger]
The machine should be carried by more 2 persons for safety

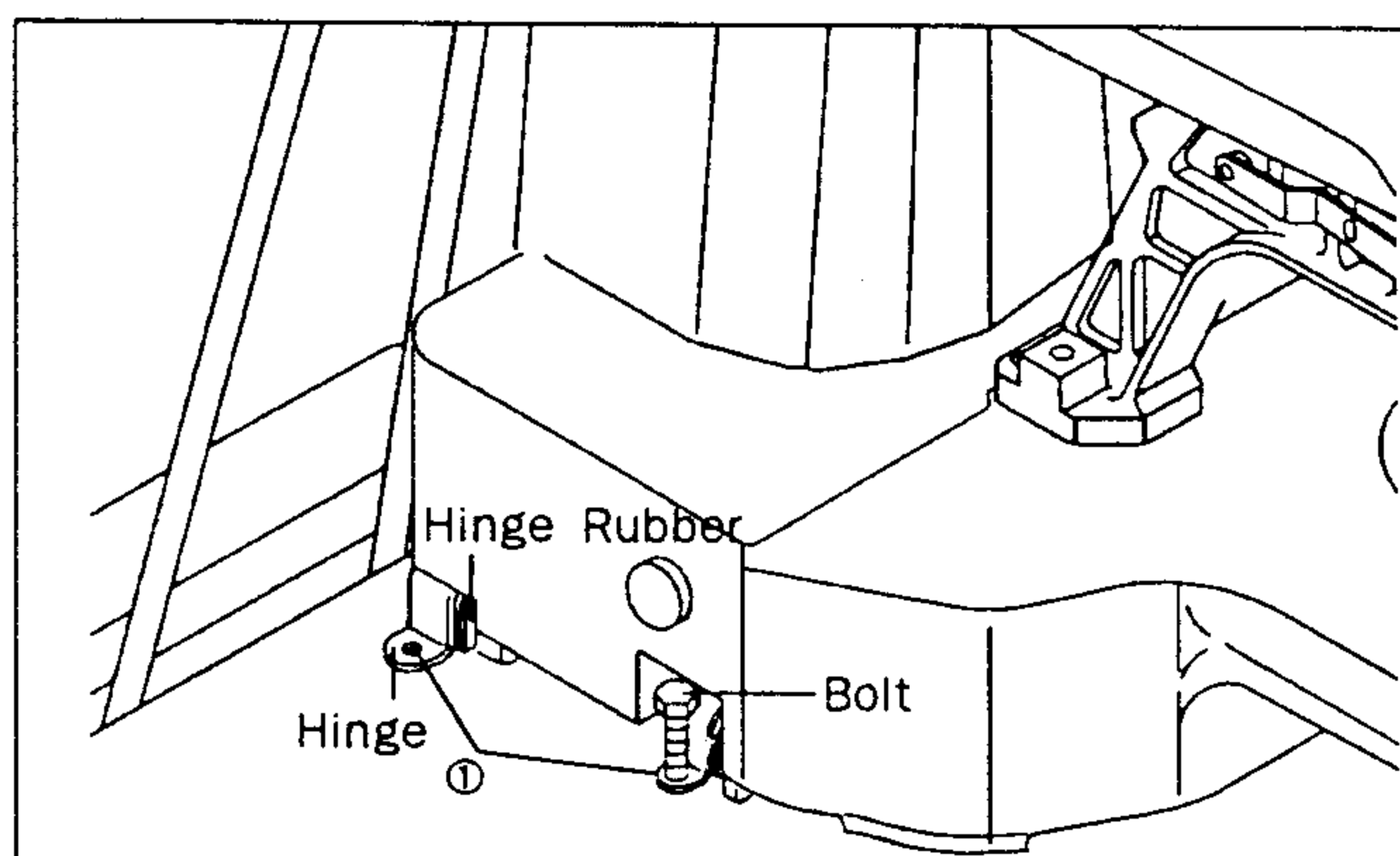

[Fig. 3]

D. Stand the machine as shown in the picture, and then fix the machine on the table after inserting the fixing bolts into the hinge metal holes of point ①.

[Danger]

Since the machine is not perfectly installed on the table, extreme care is needed when you make the machine stand up not to have any accident occurred.

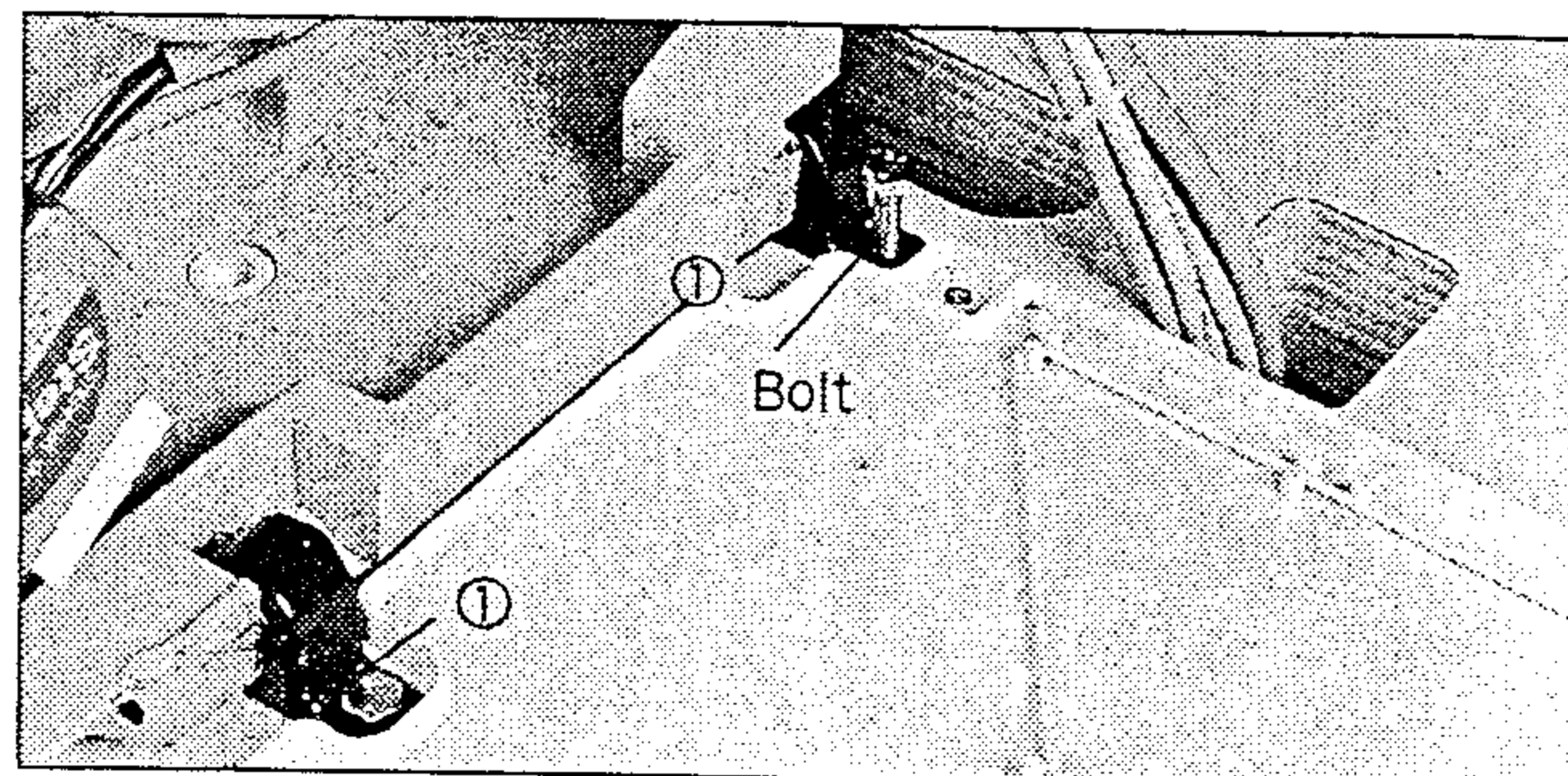

[Fig. 4]

E. Put the "V"-Belt in between the pulley and the motor while the machine is standing as in the picture.

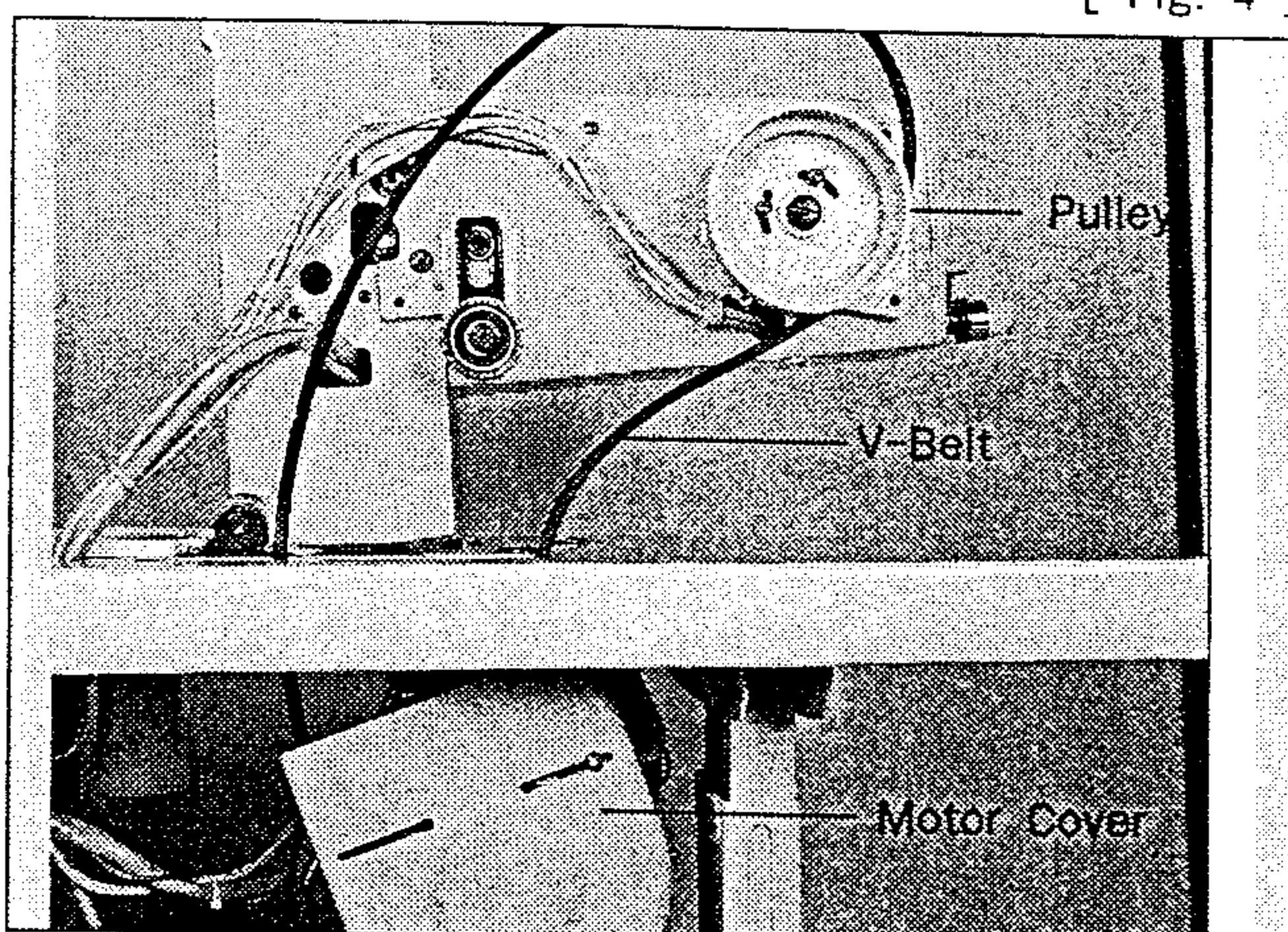

[Fig. 5]



[Warning]

Belt will crush or amputate finger or hand, keep cover in place before operating, turn off power before inspecting or adjusting.

F. After connecting the "V"-Belt, if the fixing nuts ① and ② are vertically unfastened sufficiently tension occurs in belt D due to the weight of motor C. At this point, first screw in fixing nut ① A, then nut ② in fixing screw B tightly.

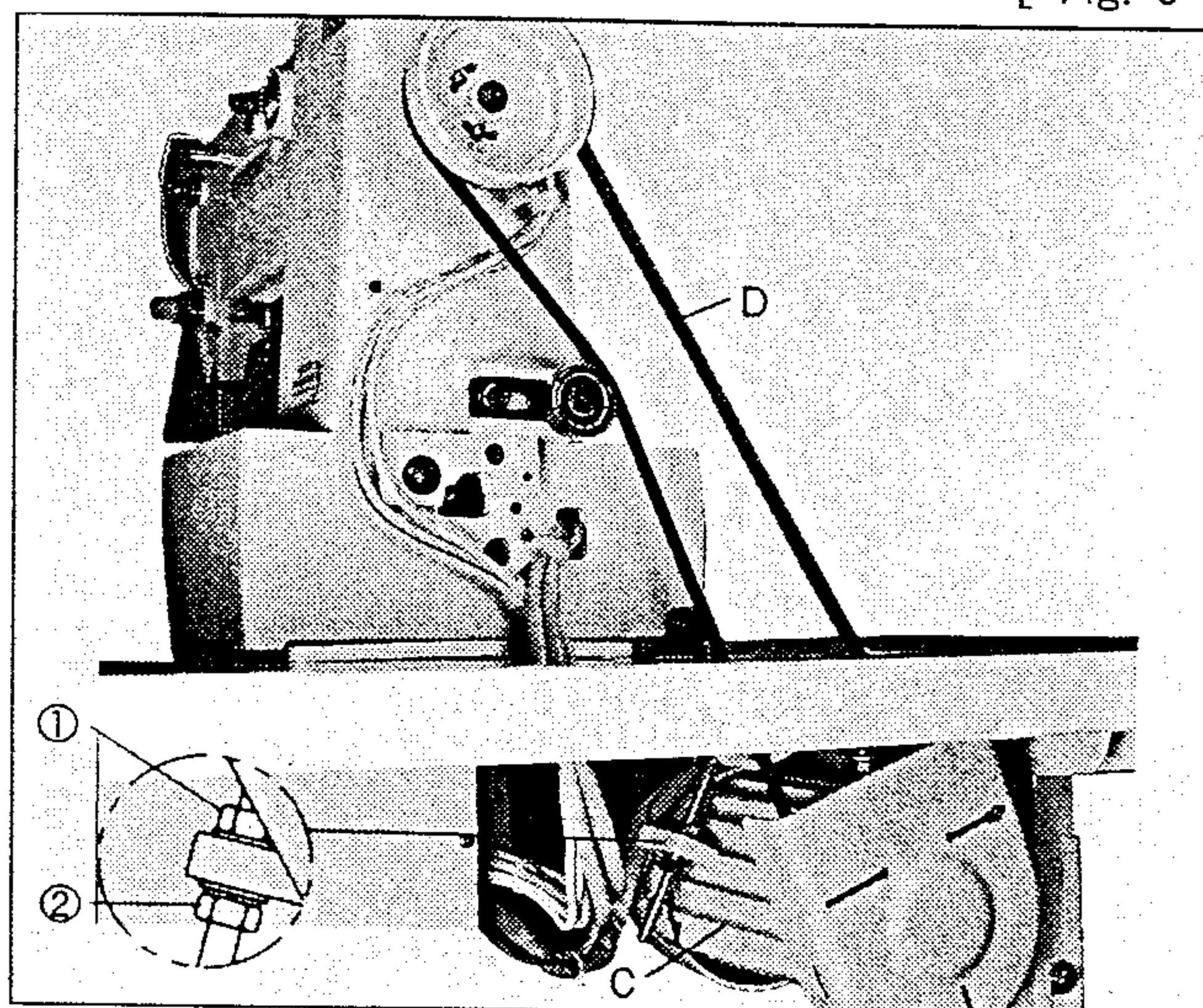

[Fig. 6]

G. Be sure to connect the earthing conductor (green) between the sewing machine and the motor. And also, connect the earthing conductor between the control box and the motor.

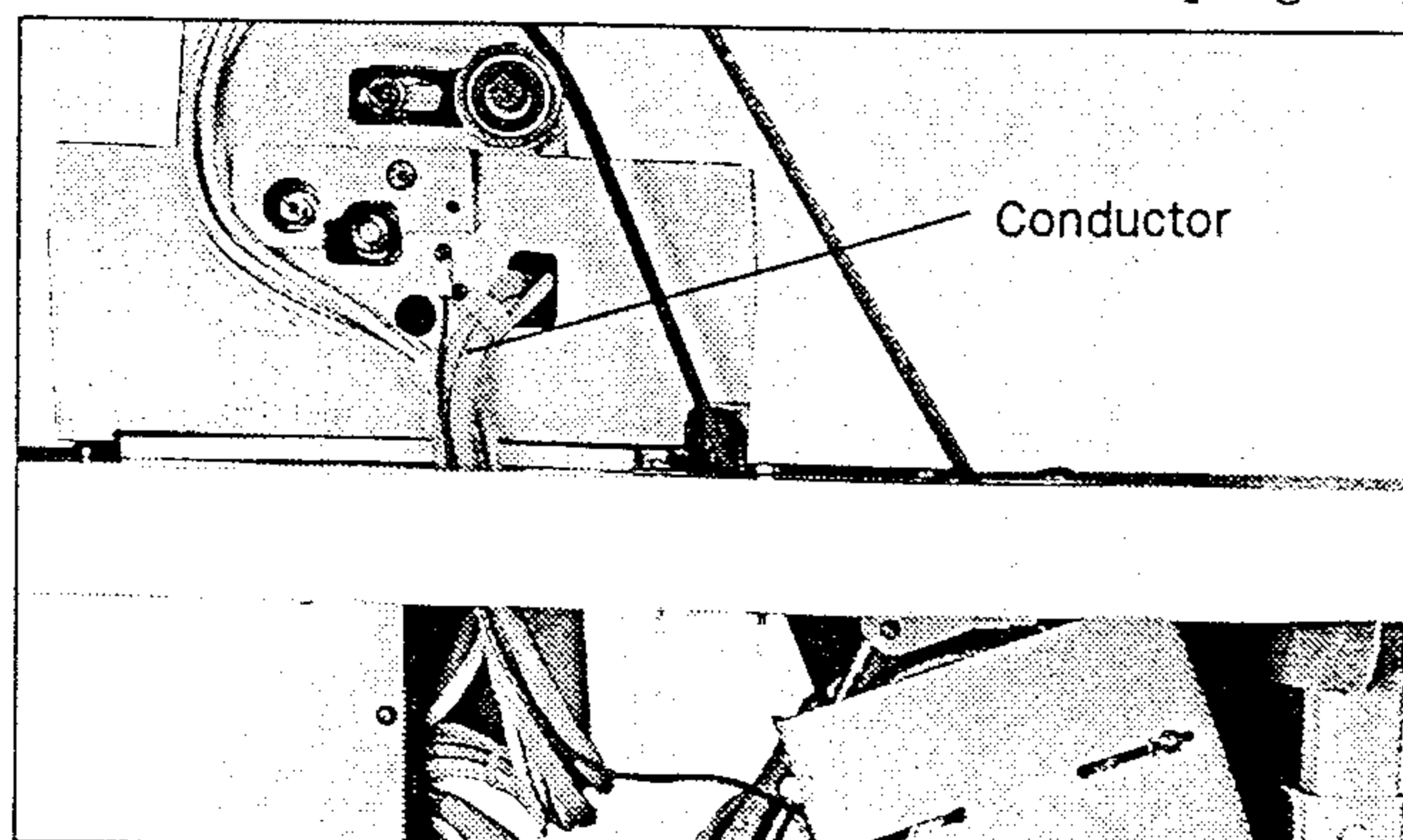

[Fig. 7]

4) Connection of Connector

Please connect the connectors of each cable connected to the machine with the control box as following \chart.

● How to link the cable

Name of Cable	Machine	Control Box
Sensor Cable	④	J10
Synchro Cable	⑤	J13
Encoder Cable	⑥	J14
Feeding Frame Solenoid Cable	⑦	J5
Trim Solenoid Cable	⑧	J6
Main Motor Cable	⑪	P1,2,3,4

Name of Cable	Machine	Control Box
X-Step Motor Cable	⑫	J2
Y-Step Motor Cable	⑬	J3
Pedal Switch Cable	③	J12
Operation Box Cable	①	J15
Air Pressure I/O Cable	⑳	J9, J11

- [Caution]
- ① MUST hold the connector to insert or pull out.
 - ② Turn off the power when you plug in or plug out.
 - ③ Should keep the cable away from 'V' belt or machine parts.

A. In case of the general, the heavy materials, thin materials, and knit(M ,H ,L ,K Type)

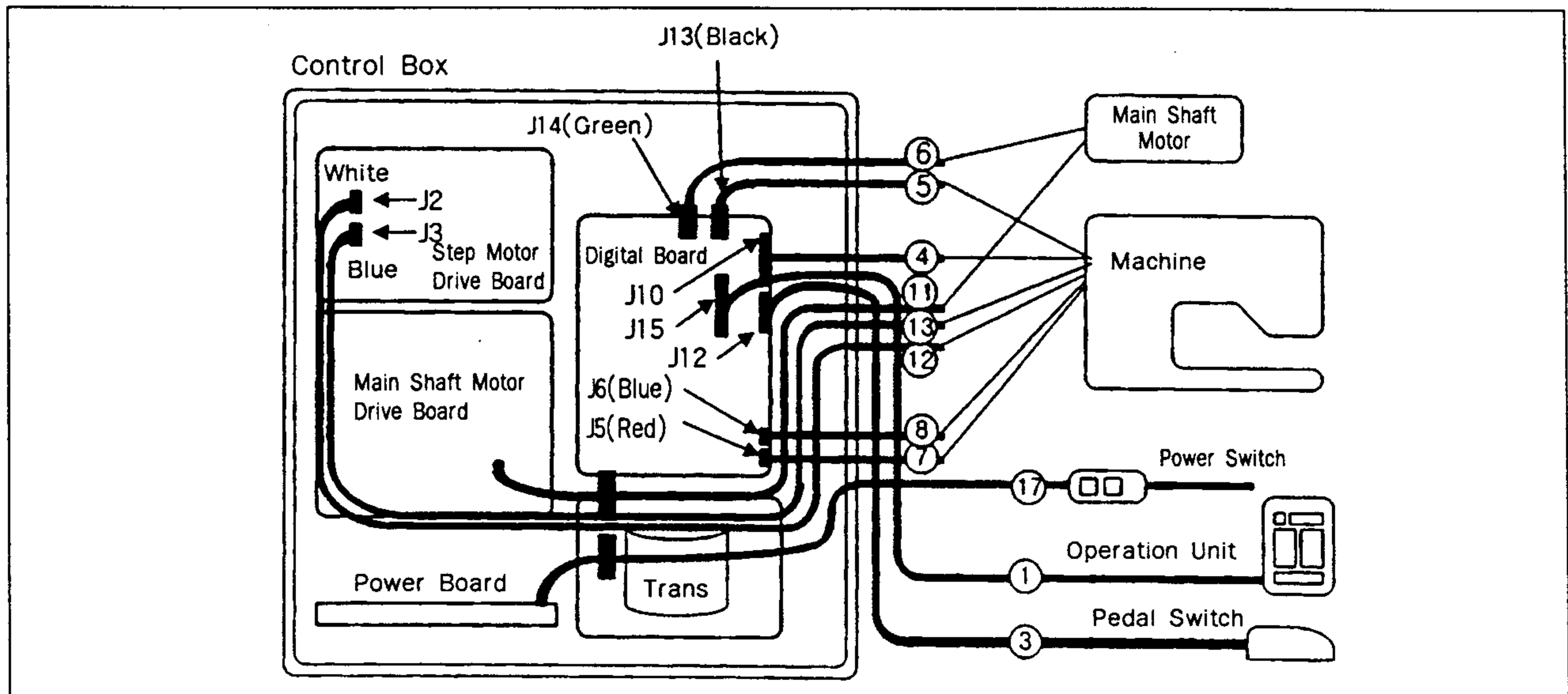

[Fig. 8-1]

B. In case of air pressure specifications

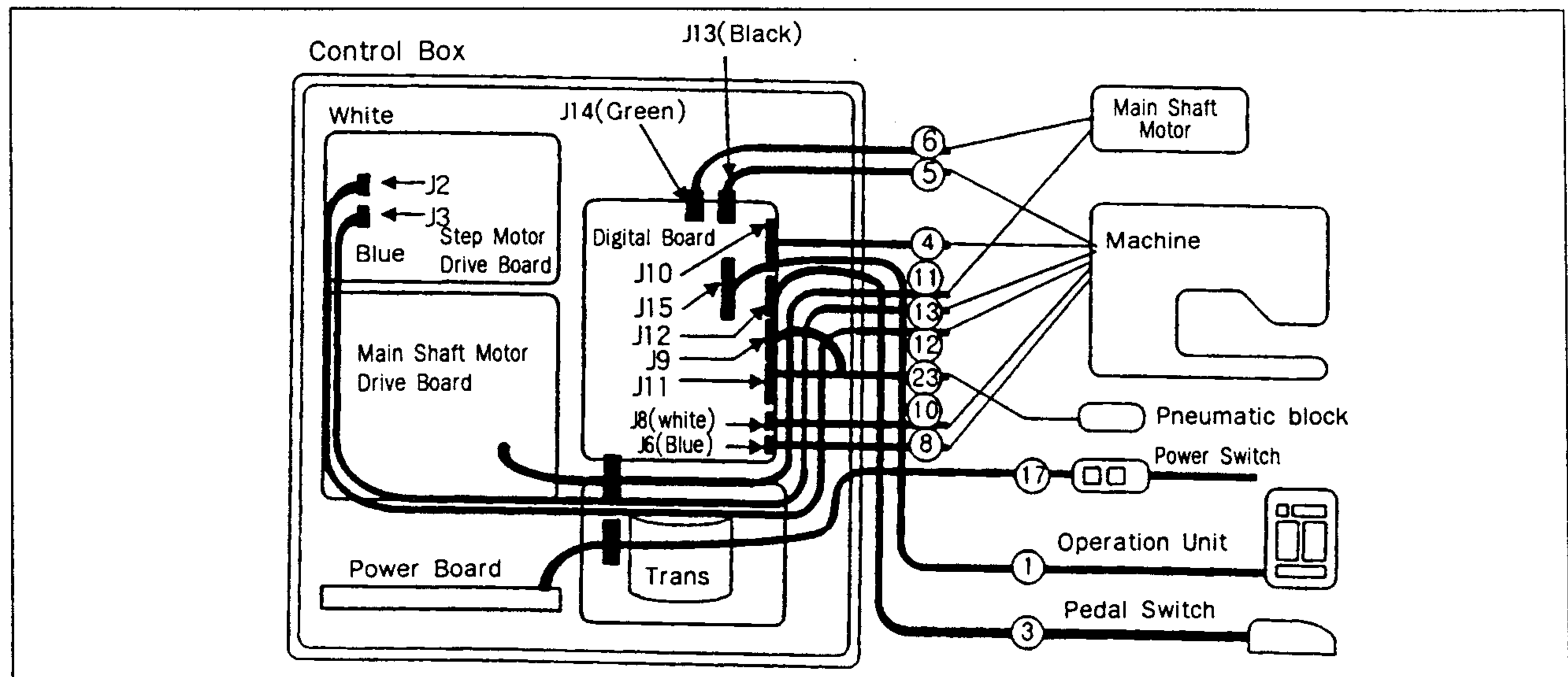

[Fig. 8-2]

- I. After the cable connections between the machine and the control box is finished, fix the cable wiring under the table as shown in the picture. (Adjust the length of the wire considering the situation of standing the machine.)

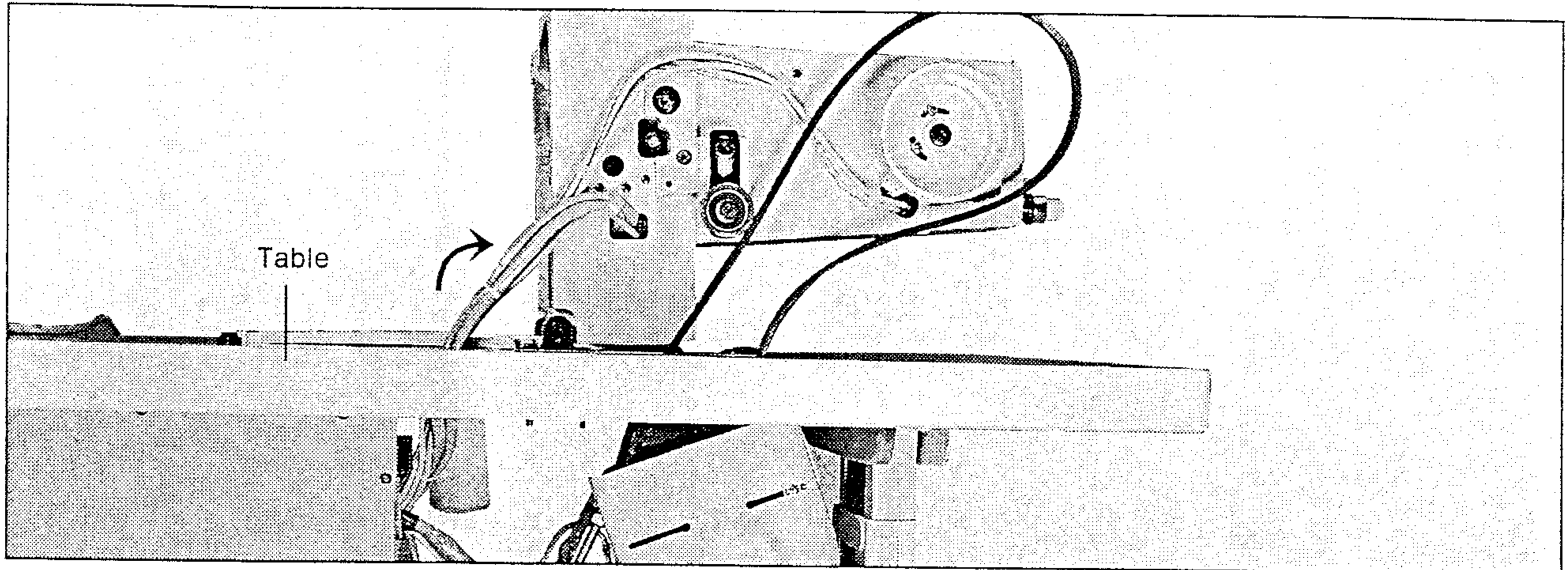

[Fig. 9]

5) The assembly of peripheral parts

- A. Attach the belt cover to the back side of machine (3 pcs) and sides (2 pcs) by using fixing bolt.

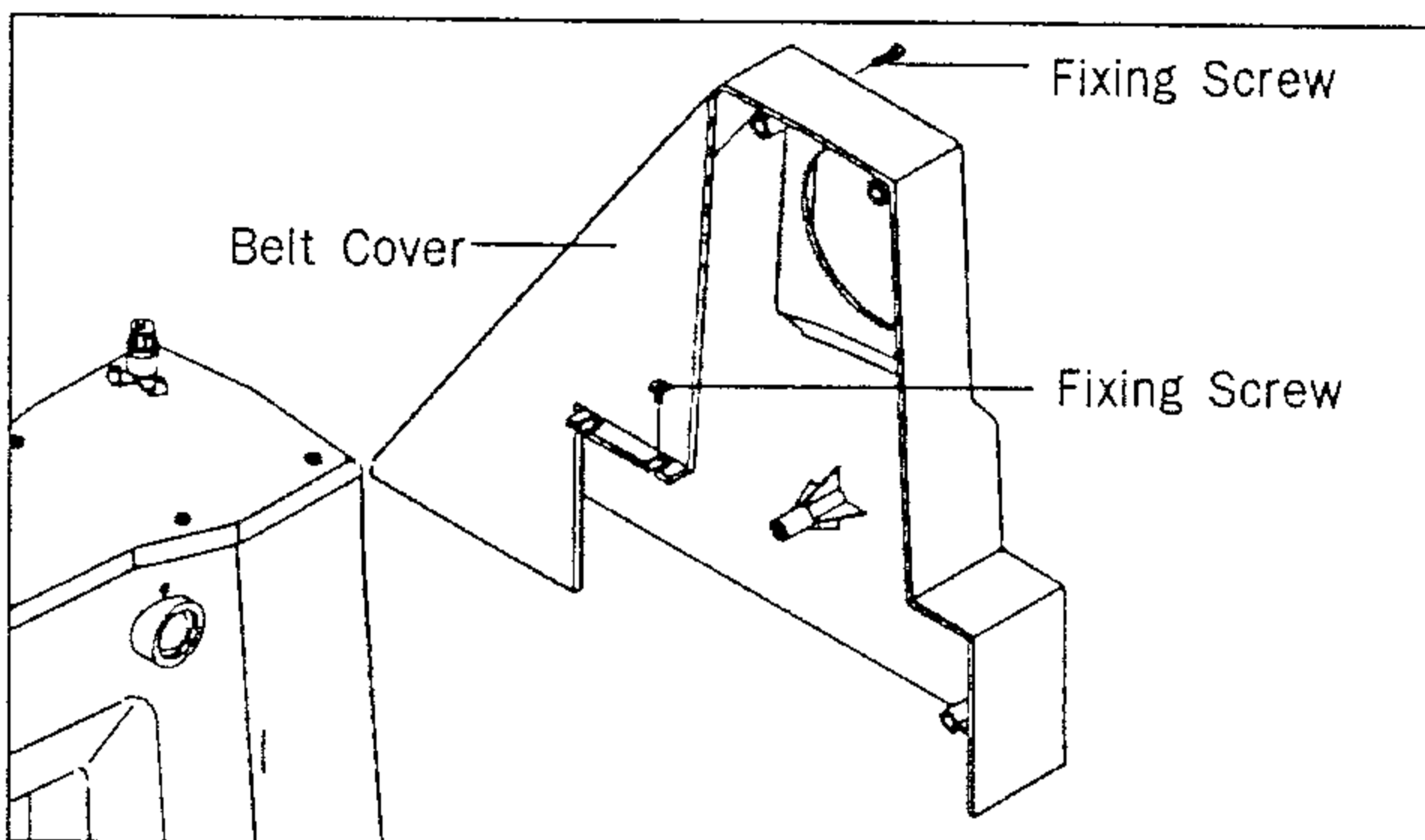

[Fig. 10]

- B. Attach the safety plate to the back side of arm by using fixing bolt.

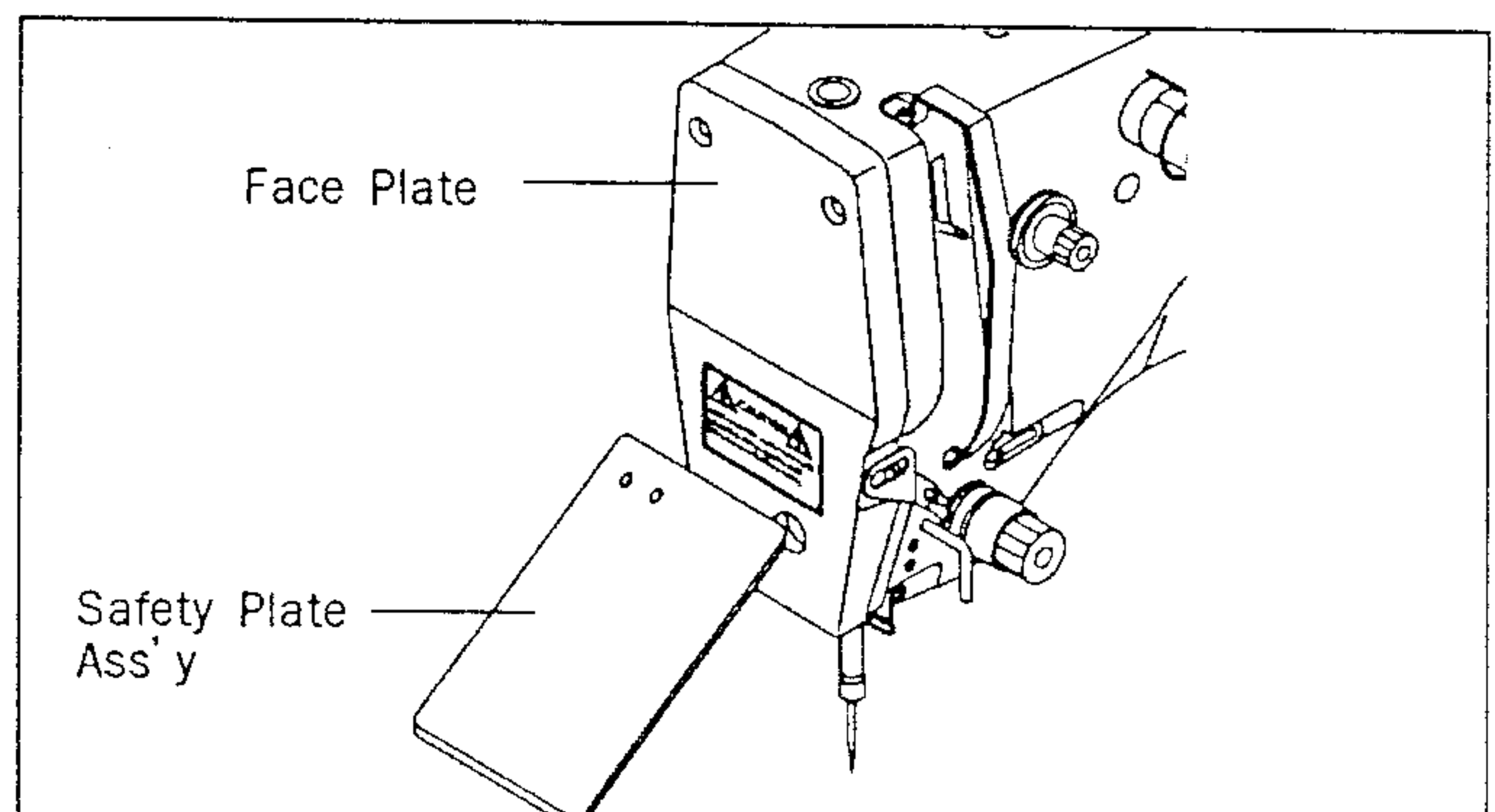

[Fig. 11]

[Caution] For safety, have the plate on during operation.

- C. Install the thread stand on the table.

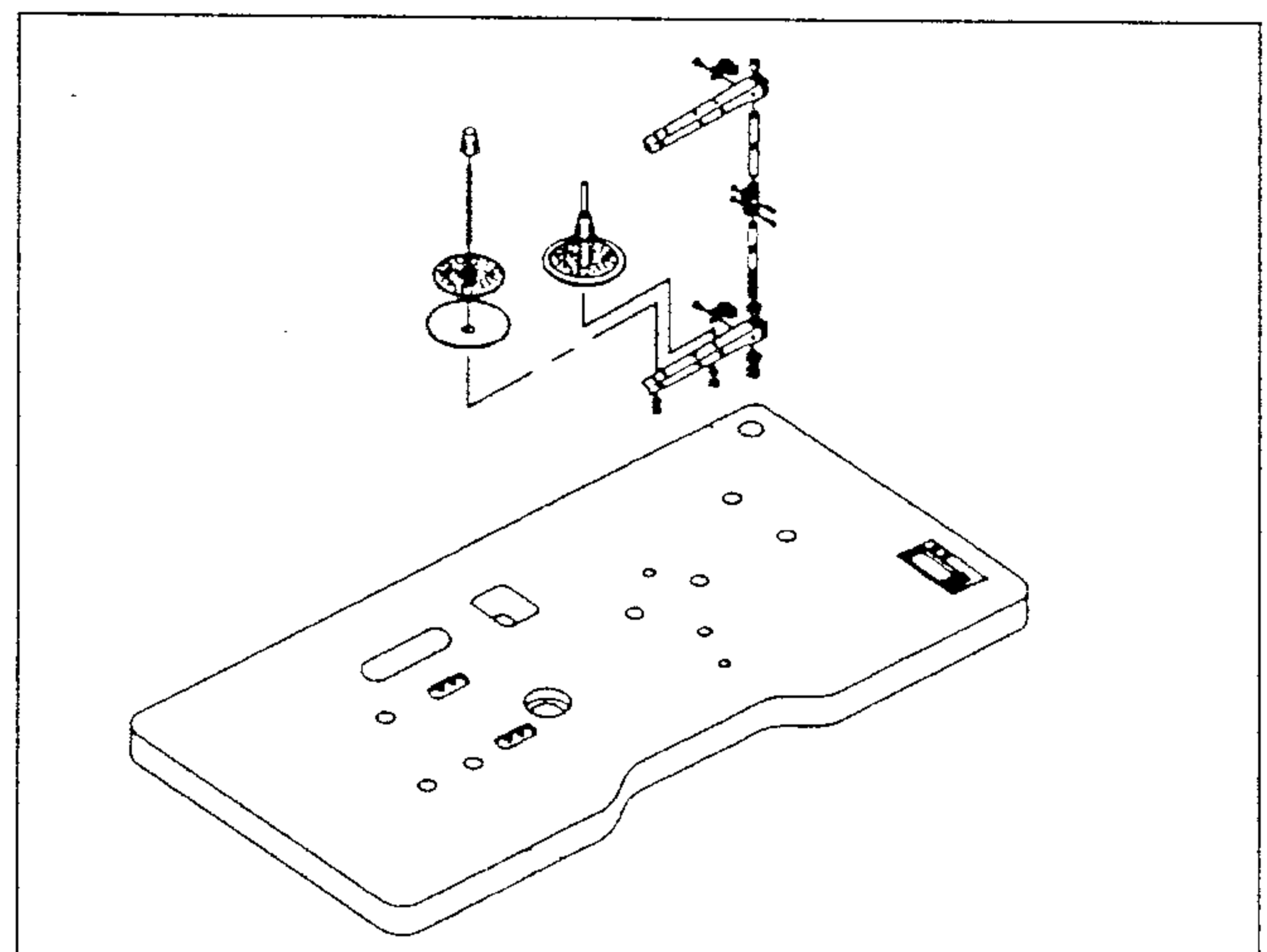

[Fig. 12]

6) Installation Method of Air Pressure Specifications (HA Type)

- 1) Assembly Method of Filter Regulator
Attach to right side of the table leg by using a bolt as shown in the figure.

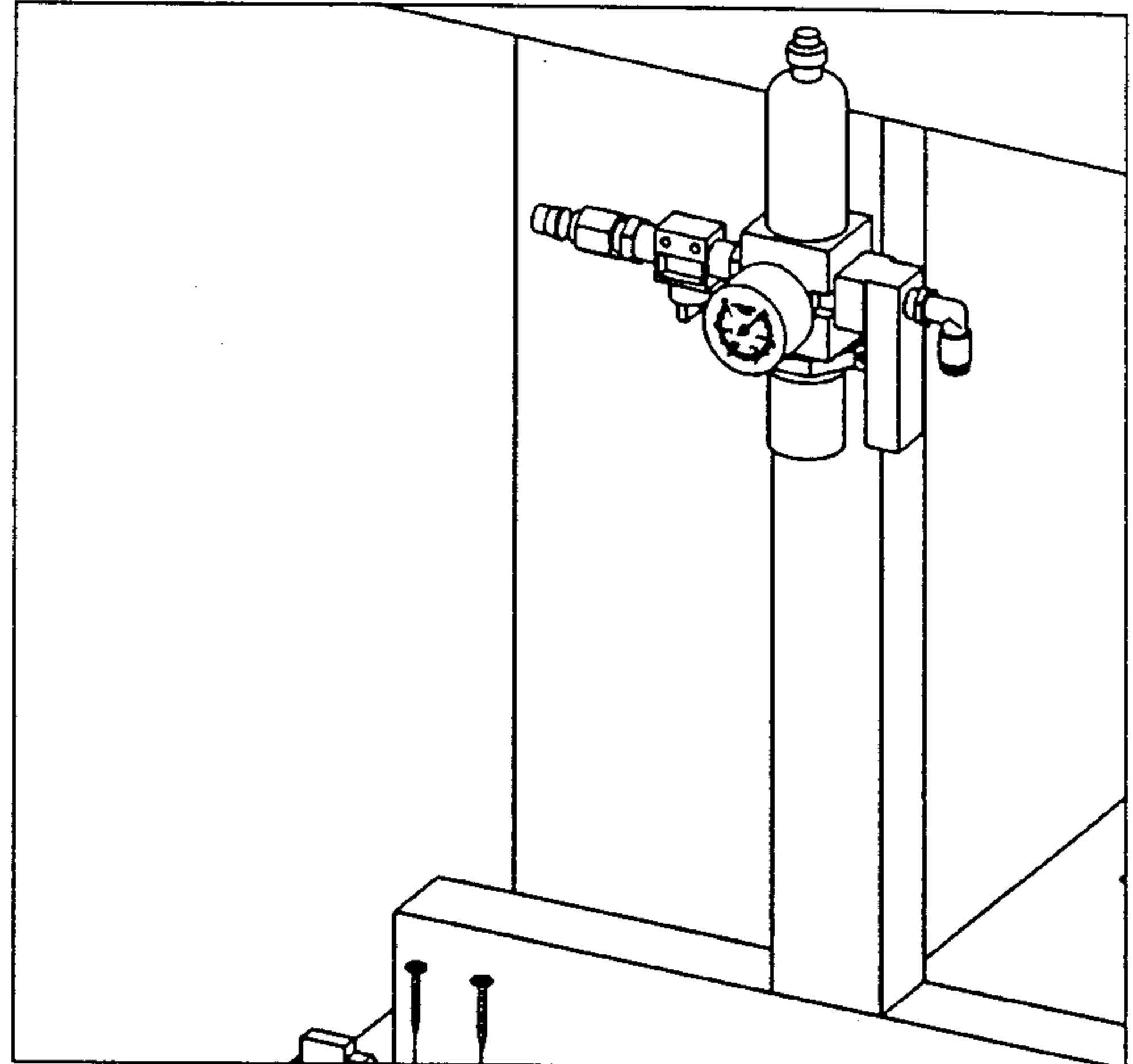

[Fig. 13]

- 2) Assembly Method of Solenoid Valve
Fix it tightly at the proper location of the table bottom by using the fixing screw.

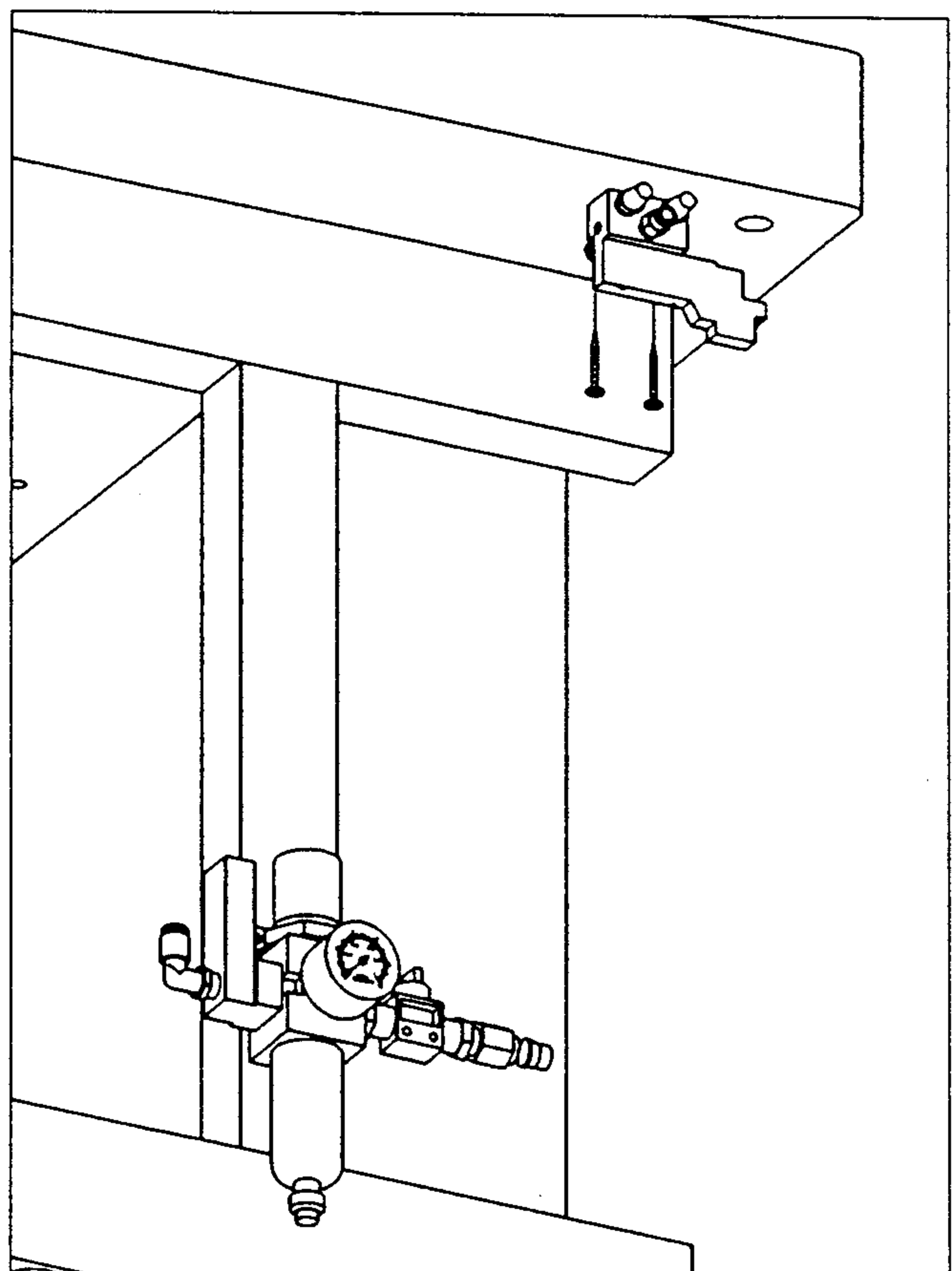

[Fig. 14]

3) Pneumatic routing for monolithic driven presser foot (HA-20 Model)

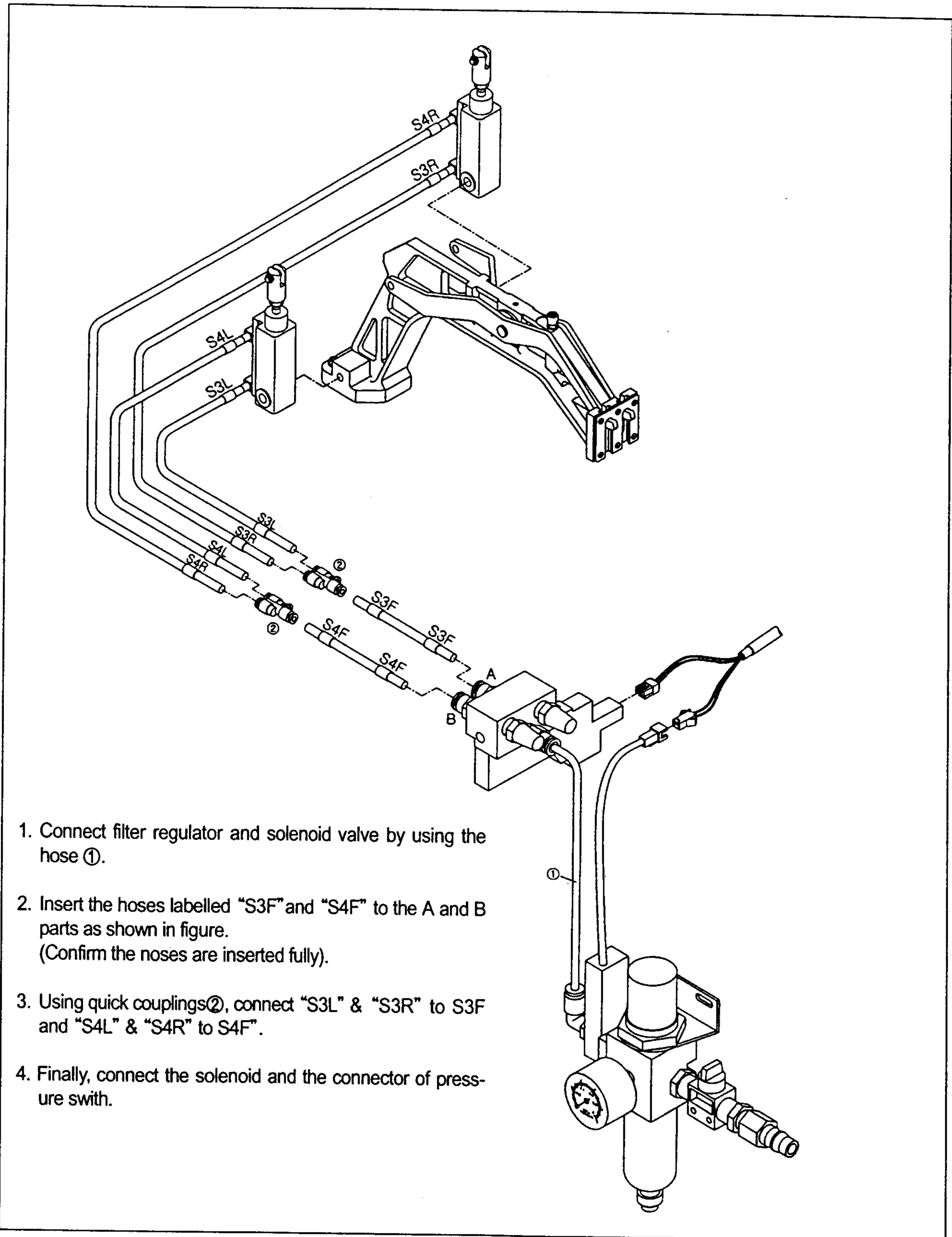

1. Connect filter regulator and solenoid valve by using the hose ①.
2. Insert the hoses labelled "S3F" and "S4F" to the A and B parts as shown in figure. (Confirm the noses are inserted fully).
3. Using quick couplings②, connect "S3L" & "S3R" to S3F and "S4L" & "S4R" to S4F".
4. Finally, connect the solenoid and the connector of pressure switch.

[Fig. 15]

4) Distribution Type of Pressure Foot

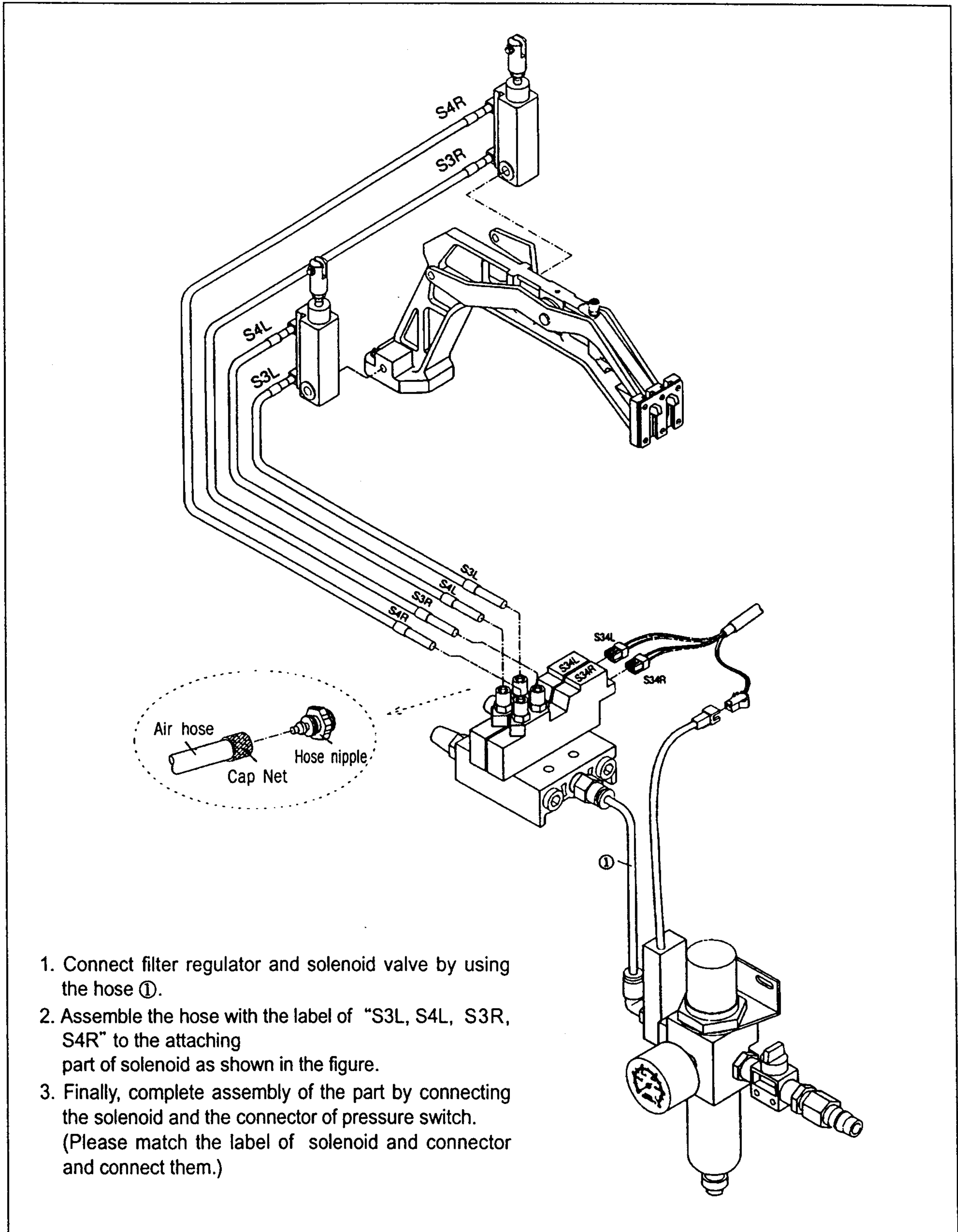

[Fig. 16]

7) Mounting Option Wiper and Adjusting Method(HY Type)

- A. Fix the wiper base plate with screw as shown in the figure.

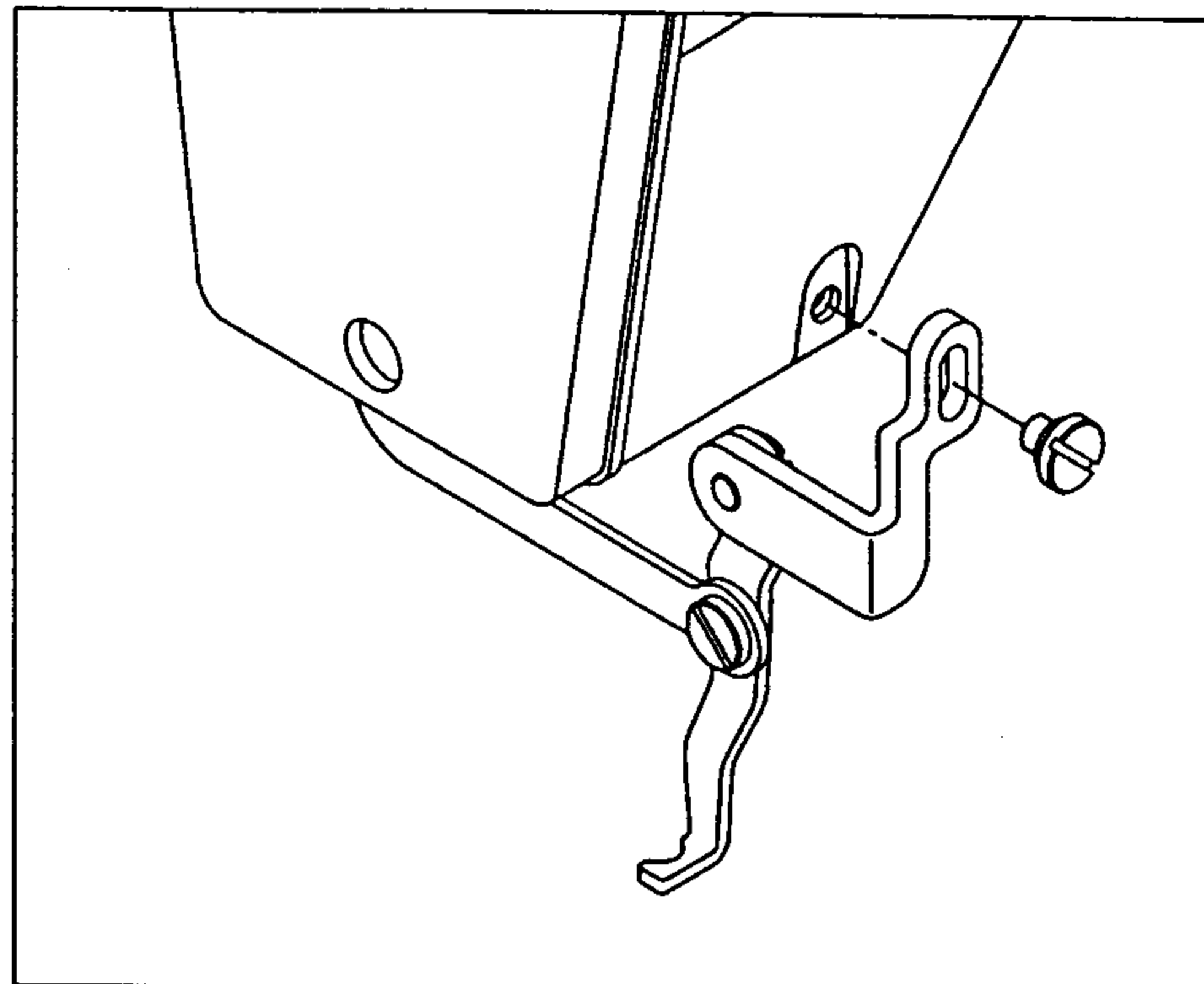

[Fig. 17]

- B. Fix the wiper base at the opposite direction with two screws as shown in the figure.

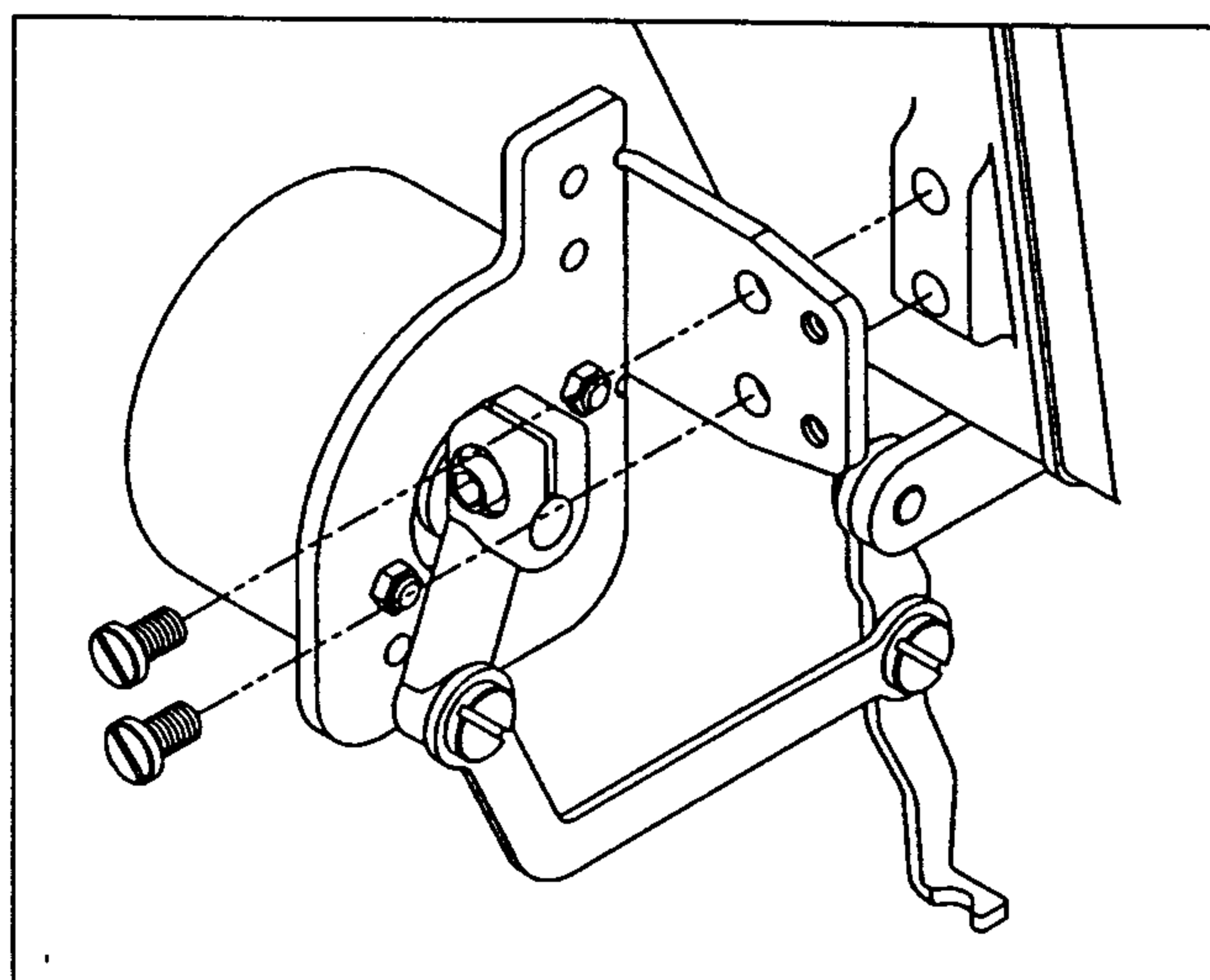

[Fig. 18]

- C. Connect the connector located at solenoid with the connector came out from arm.

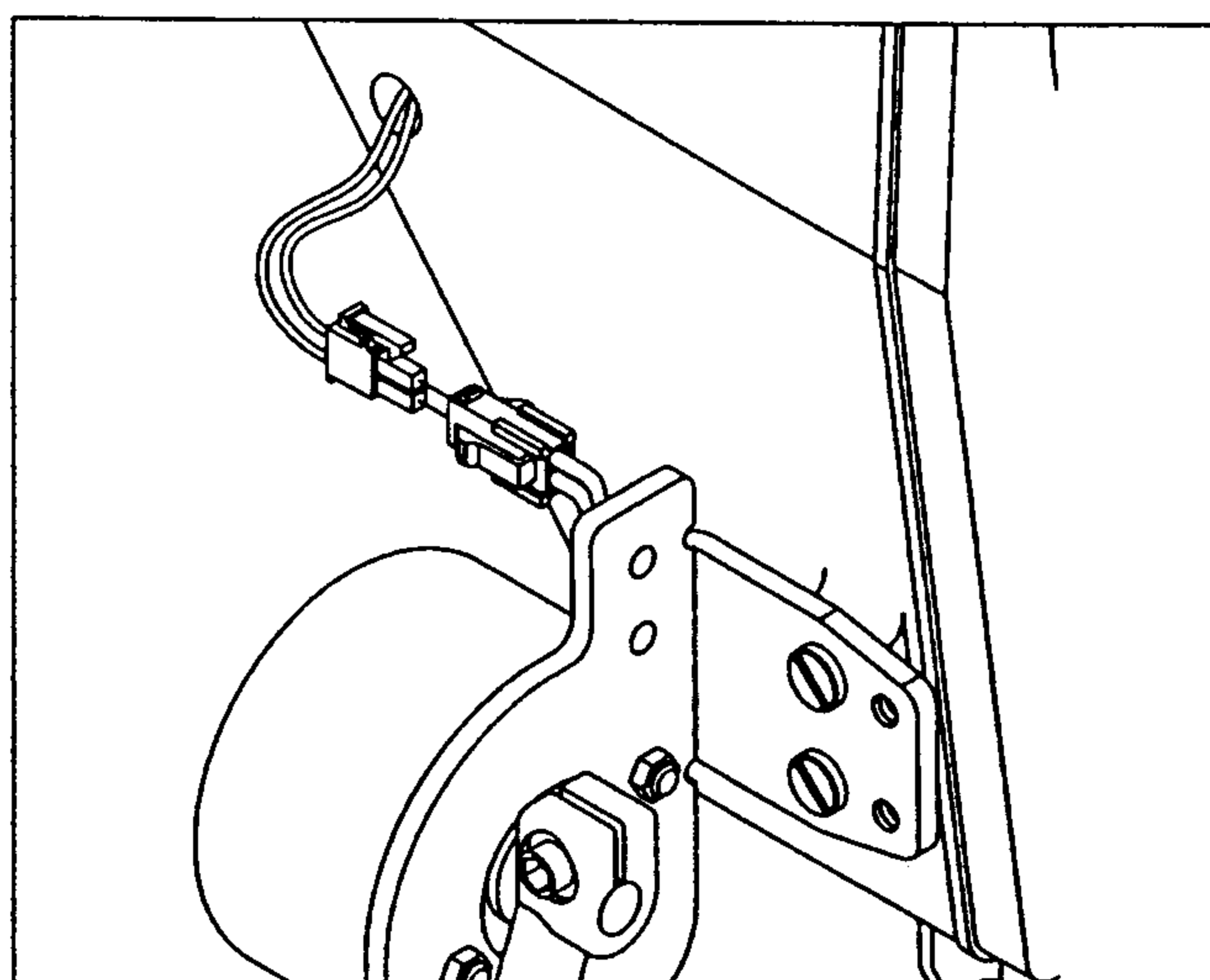

[Fig. 19]

- D. Unfasten the joint screw② of wiper base plate and when the needle center becomes a straight line, adjust the wiper base plate③ up and down that the interval between joint screw② and the wiper becomes 14.5~15.5mm, then fasten the joint screw②.

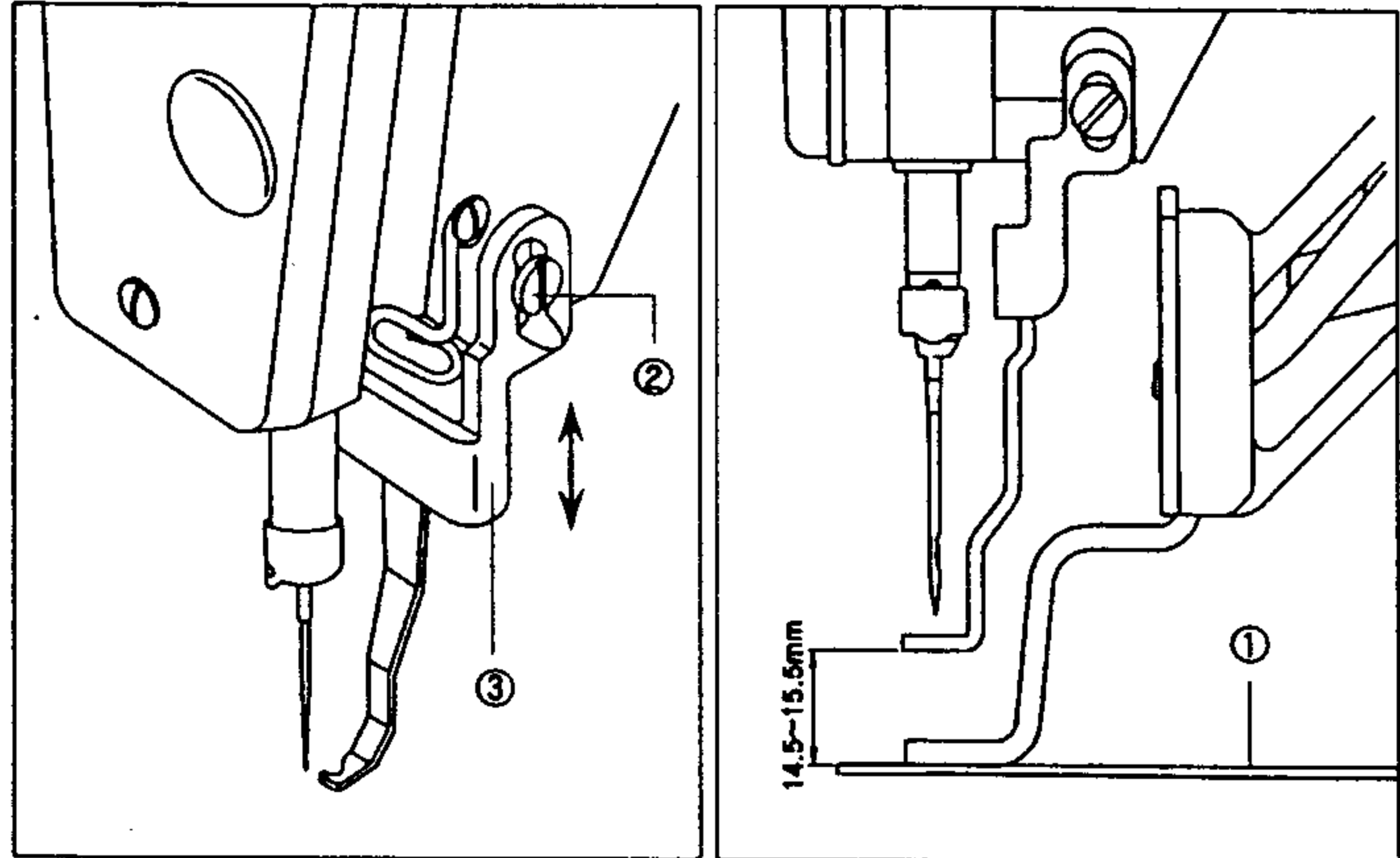

- E. Unfasten wiper crank joint screw④, and when maximum operation of wiper, after adjusting wiper crank⑤ to the right and left that the interval between needle center and wiper becomes 25mm, then fasten the crank joint screw④.

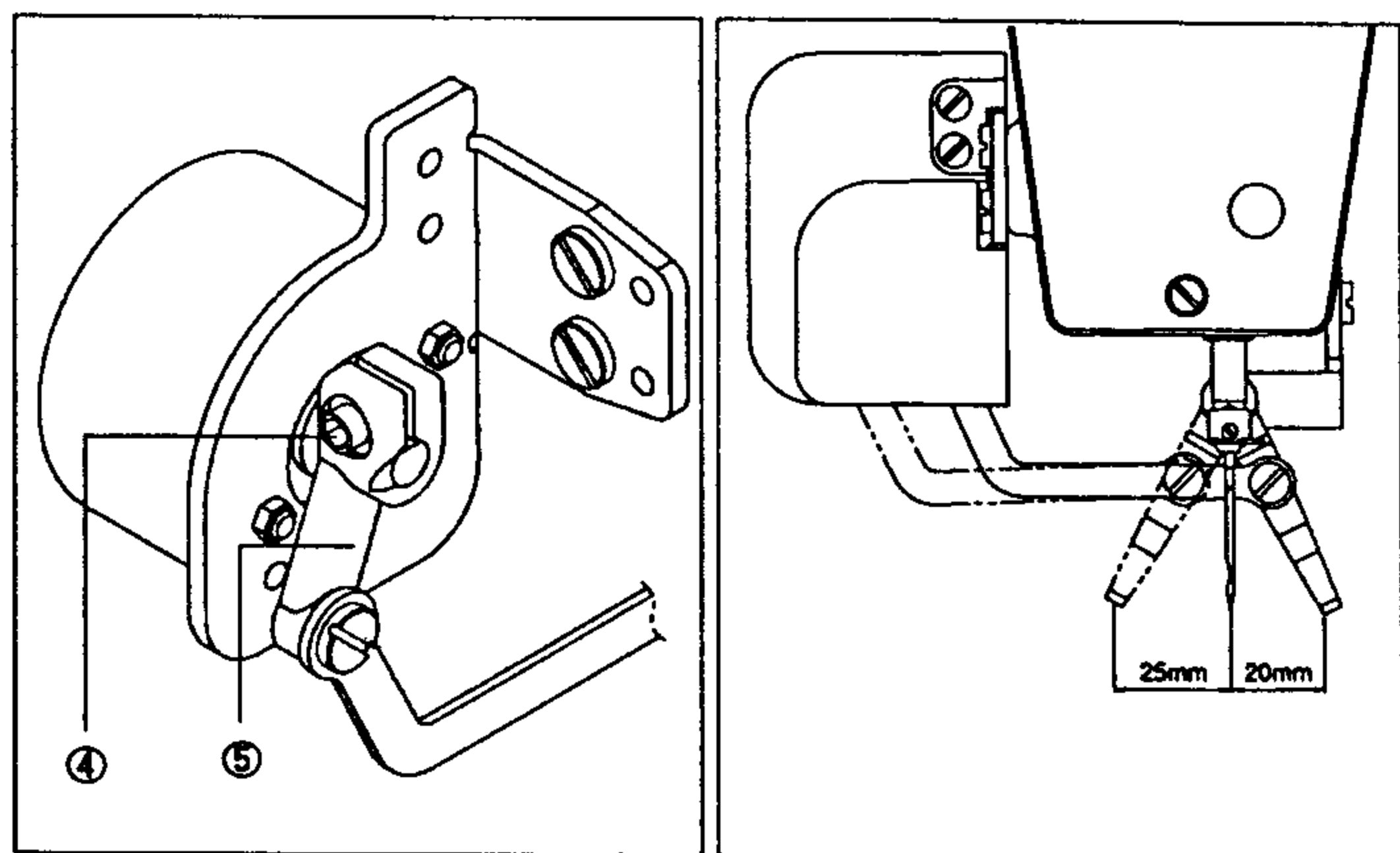

- F. Finally, after arranging the connector as shown in the figure, attach the wiper cover⑥ by using wiper cover joint screw⑦.

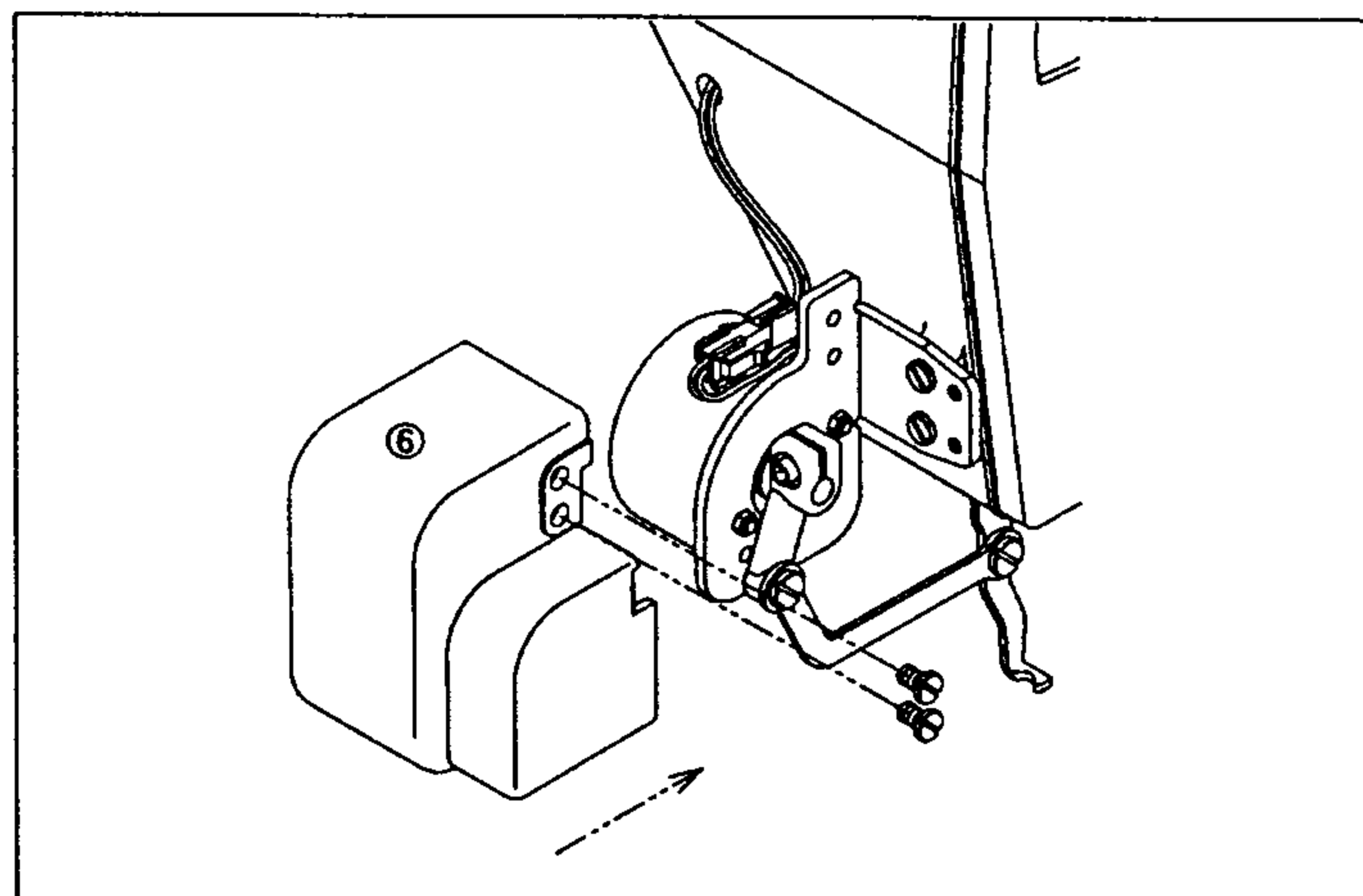

[Caution]

You should set function number A-18 related to general sewing machine at "100" in order to use wiper solenoid.

WIRING AND GROUNDING

1) Specification of the power plug

① Single Phase AC95V~125V

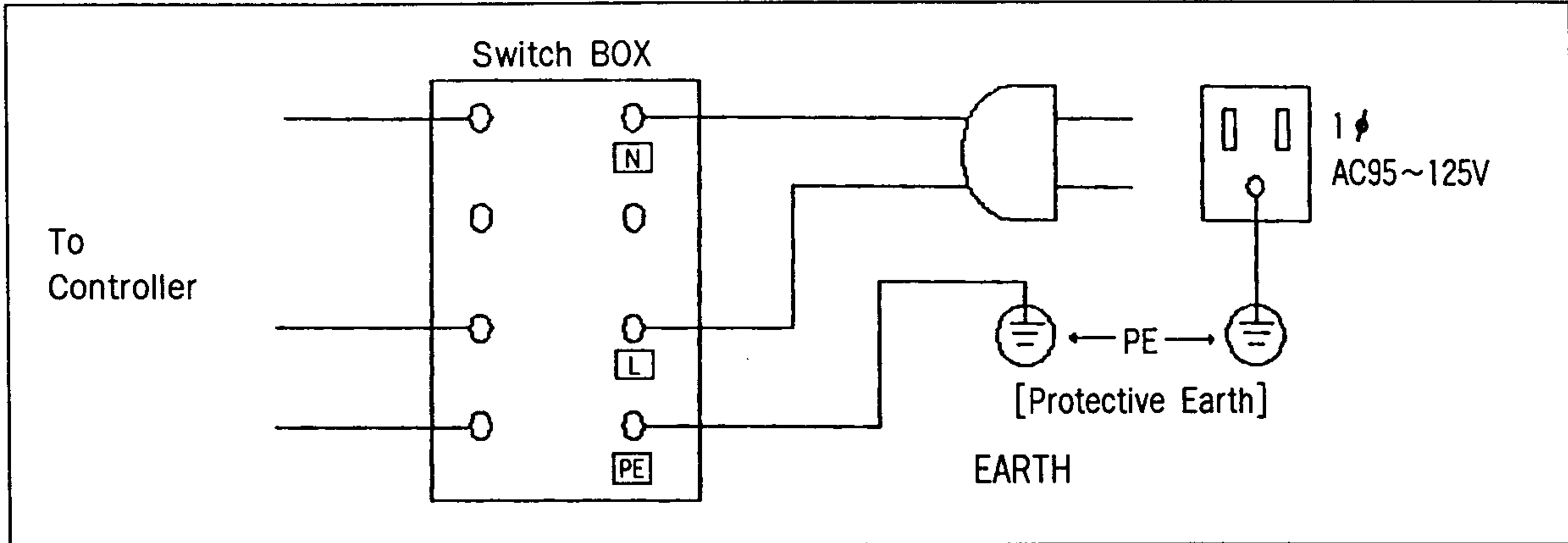

② Single Phase AC190V~230V

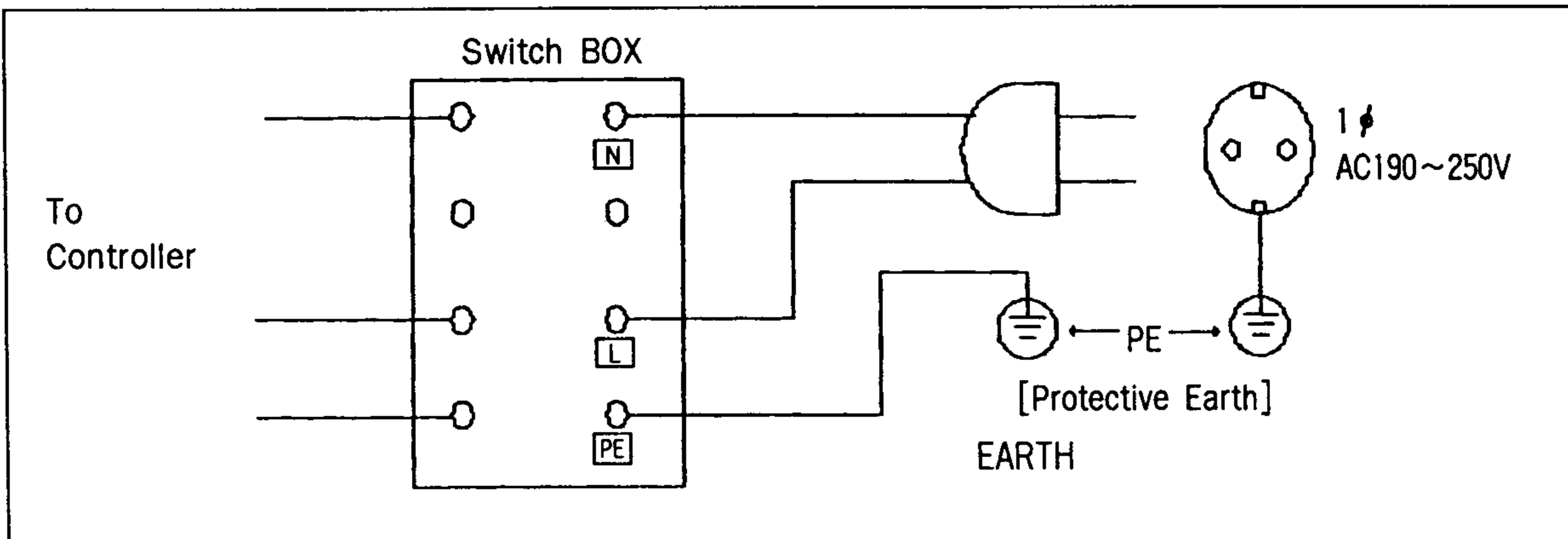

③ Three Phase AC190V~480V (Note: This diagram is not for european market)

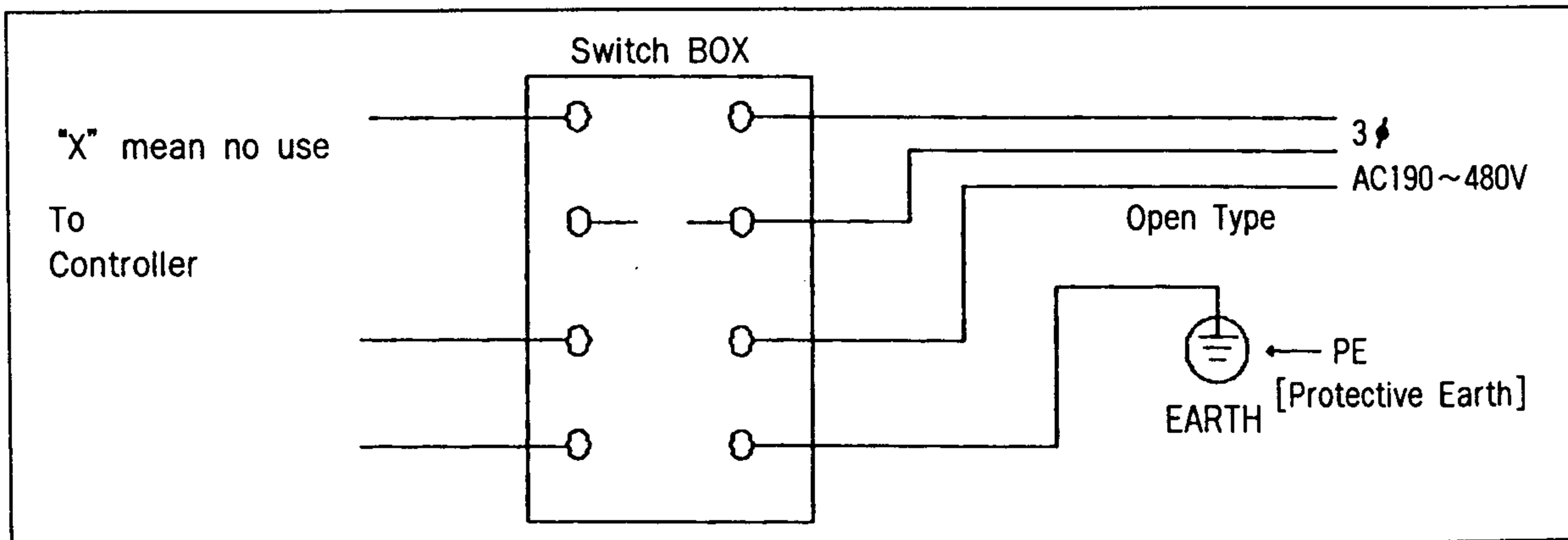

- * Be sure to econnect Protective Earthing
- * Make sure to use the circuit braker on the input line if you use 3 phase

2) Specification of electric current in wiring of power plug

Be sure to use wiring materials which can stand electric current of higher then 15A

Each Fuse capacity (Bartack 1201Series)

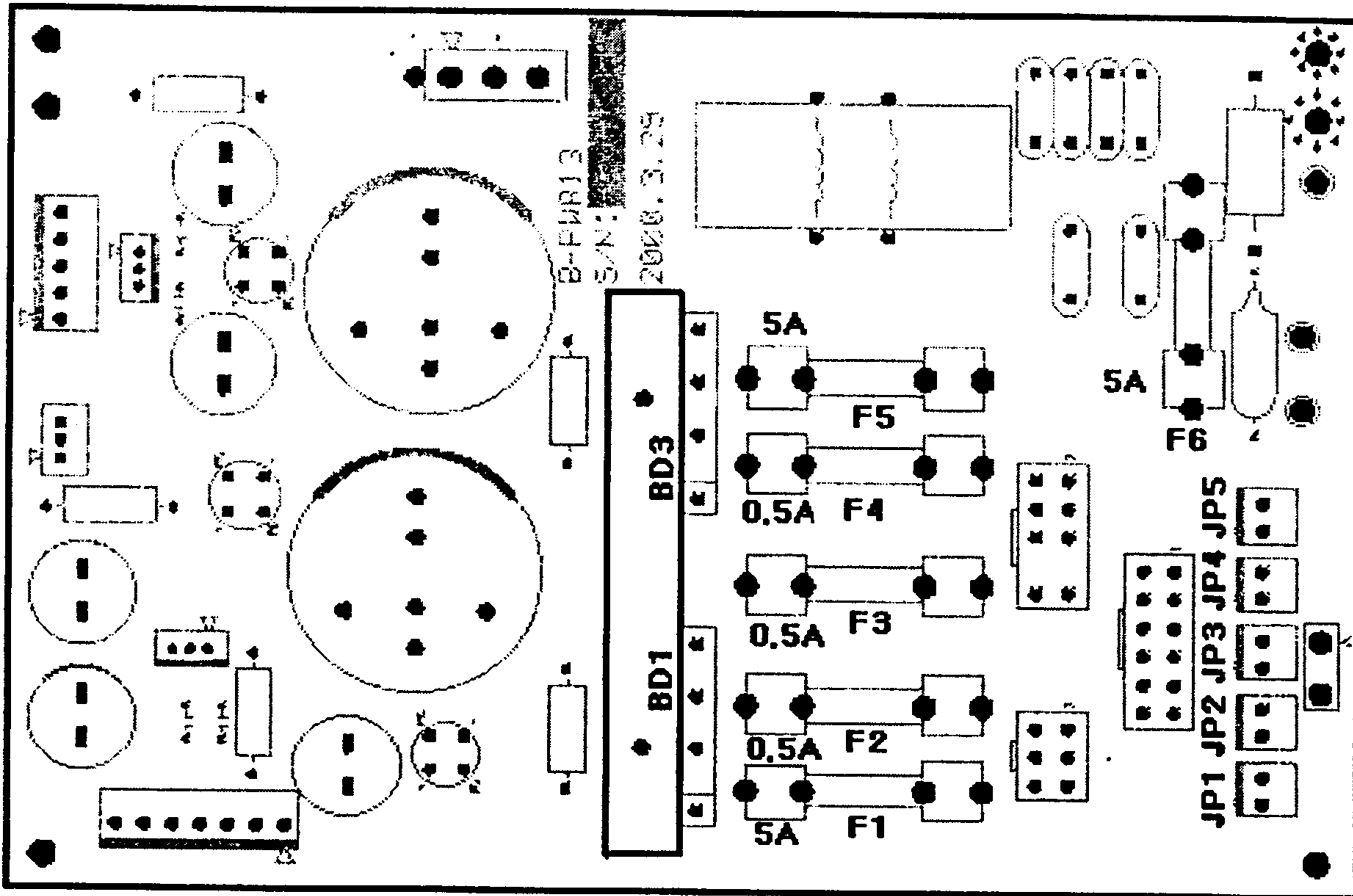

NO	DEVICE NO.	FUSE CAPACITY		FUNTION	ETC.
		VOLTAGE	CURRENT		
1	F1	AC250V	5A	STEP MOTOR	
2	F2	AC250V	0.5A	STEP OPERATING	
3	F3	AC250V	0.5A	FAN	
4	F4	AC250V	0.5A	DEGTAL B/D OPERATIONG	
5	F5	AC250V	5A	SOLENOID	
6	F6	AC250V	5A	BARTACK MAIN	

When you change the Fuse you should TURN OFF the POWER

8) Connecting the Power Code

- Specification of Voltage
Indication of voltage is described as below in the tag of power code.
 1. Never use in different voltage from standard.
 2. When changing the using voltage, refer to the 「Changing the Voltage」
- Connection of single phase
(100V, 110V, 120V, 200V, 220V, 240V)
- Connection of three phase
(200V, 220V, 240V, 380V 440V)

V

The Electric Specification of This Machine is
Connected Under Marked

1) (1 Phase), (3 Phase)

2) 110V, 220V, 240V, 380V, 415V

9) Changing the Voltage

In the voltage of 95~230V and 190~480V, you can change the voltage with only changing the position of the power voltage connector.

- Voltage Change of 95~230V
Model of Transformer : SPS-1201-110

Input Voltage	Connector position of Power Voltage
95V ~ 105V	JP3
106V ~ 115V	JP4
116V ~ 125V	JP5
190V ~ 210V	JP1
211V ~ 230V	JP2

- Voltage Change of 190~480V
Model of Transformer : SPS-1201-220

Input Voltage	Connector position of Power Voltage
190V ~ 210V	JP1
211V ~ 230V	JP2
231V ~ 250V	JP3
345V ~ 415V	JP4
416V ~ 480V	JP5

■ If the power voltage connector is set up badly, the control box can be damaged.
 If you want to change 100V~220V into 200~440V, or vice versa, you should exchange the transformer.

■ Don't use in case of power voltage is 380V in European area.

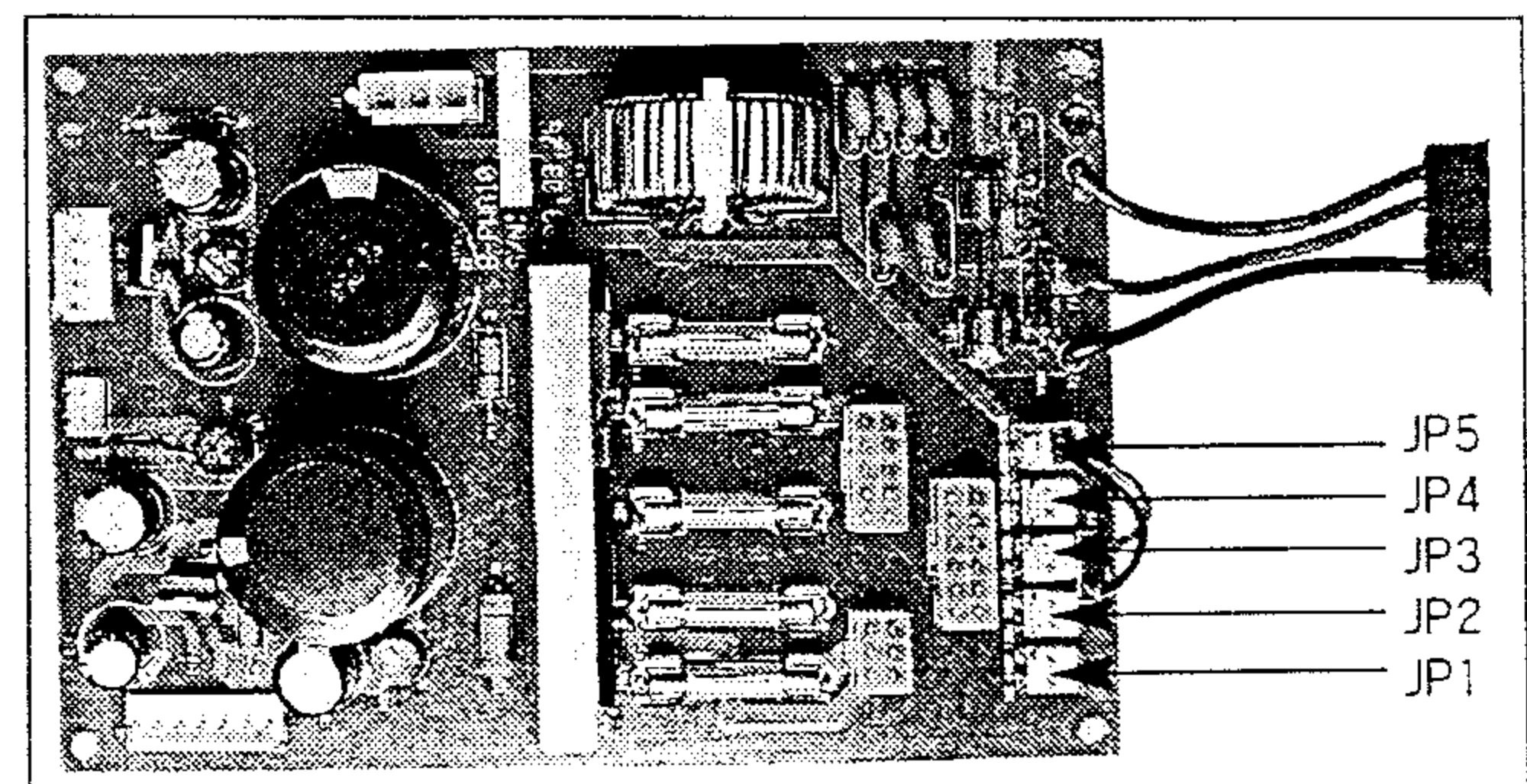

[Fig. 20]

5

PREPARATIONS BEFORE OPERATING THE MACHINE

1) How to supply oil

- A. Check the amount of oil left in the oil tank which is installed on the arm and supply oil sufficiently.

[CAUTION]

Be sure to supply oil when operating the machine for the first time or when the machine has not been used for a long time.

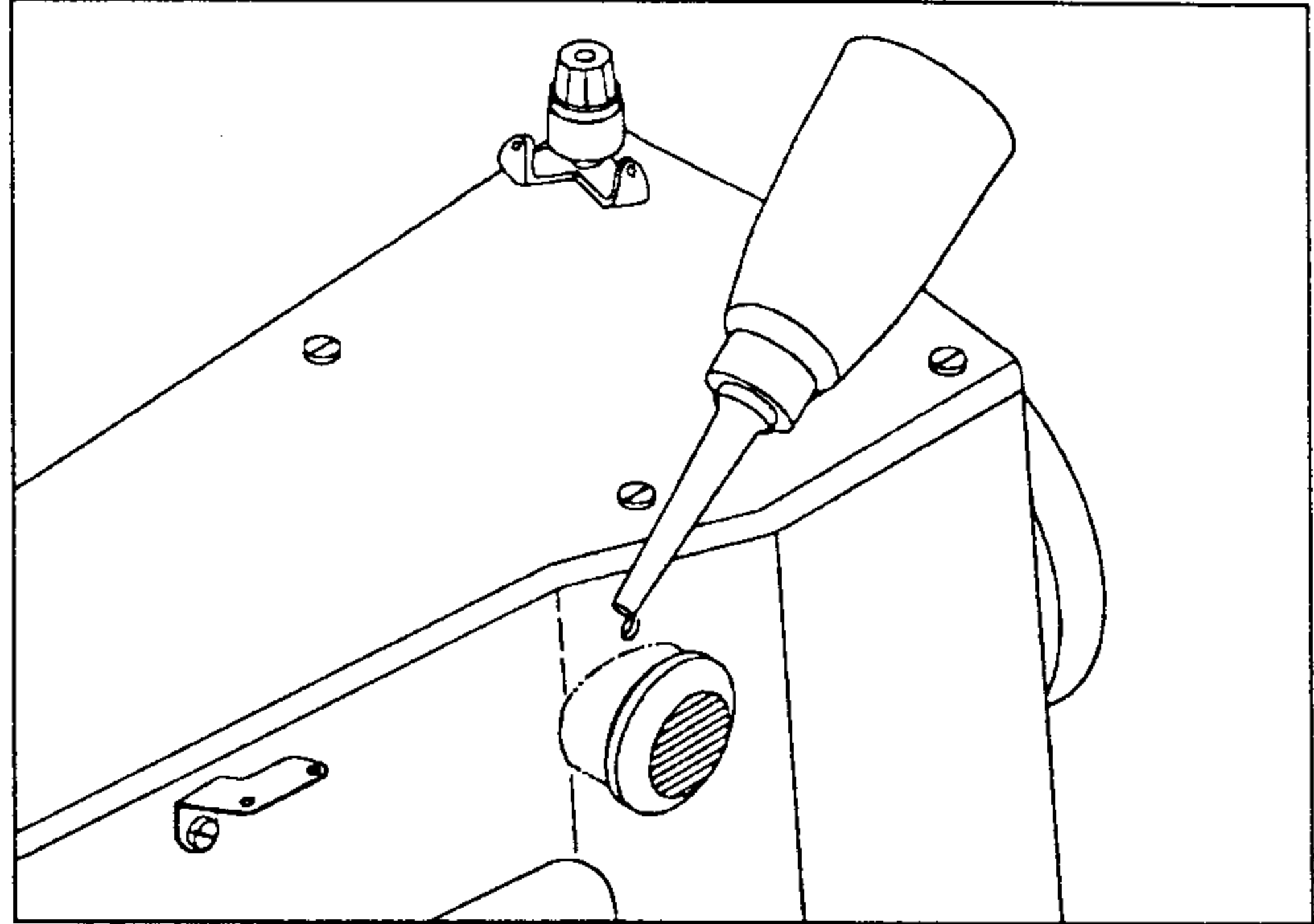

[Fig. 21]

- B. Check the remained amount of oil from the right window(Oil gauge window) of oil tank installed on the bed as seen in the figure, then supply oil enough through the lubrication hole on the bed cover.

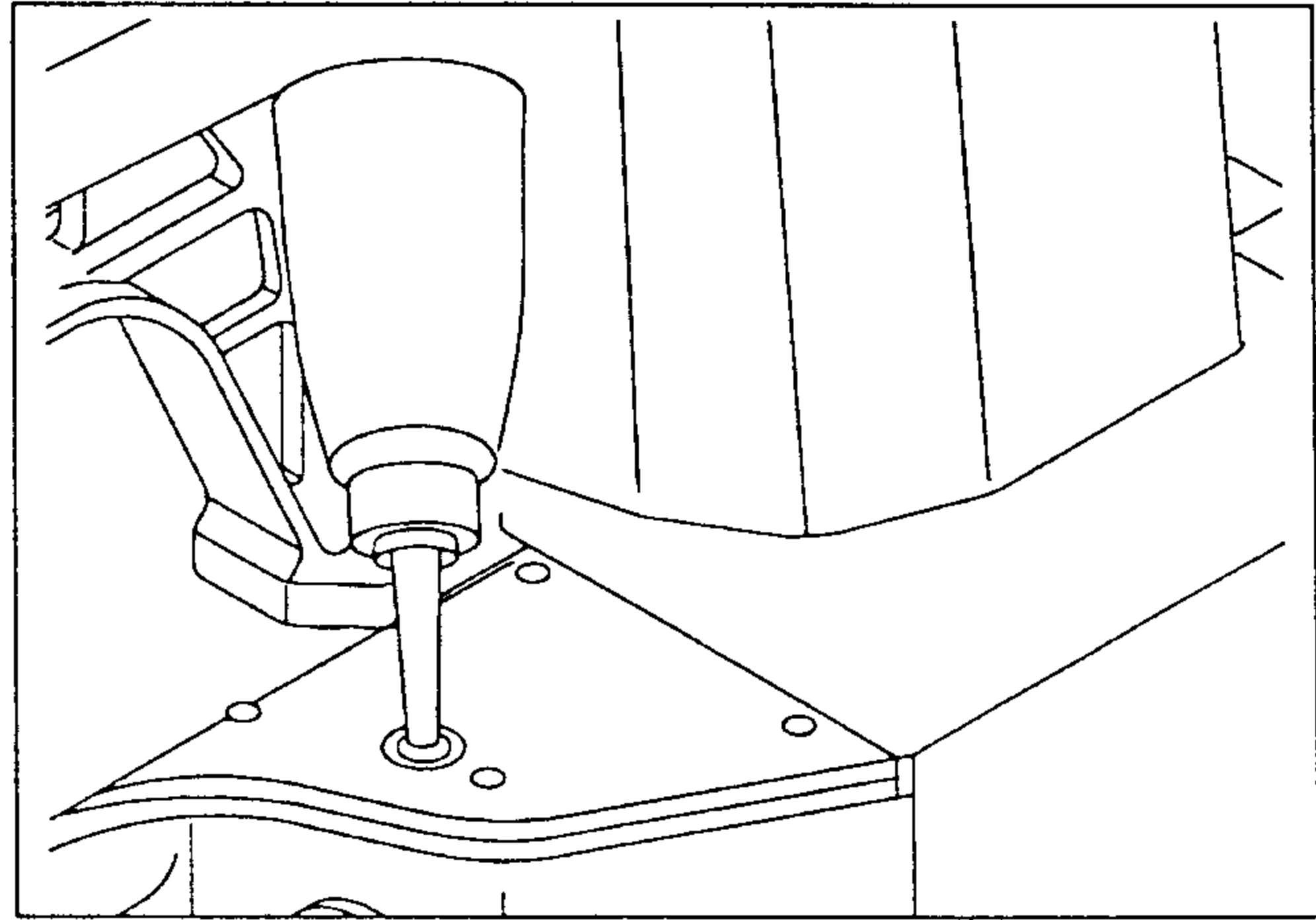

[Fig. 22]

- C. Supply oil into the hole in the upper part of the arm.

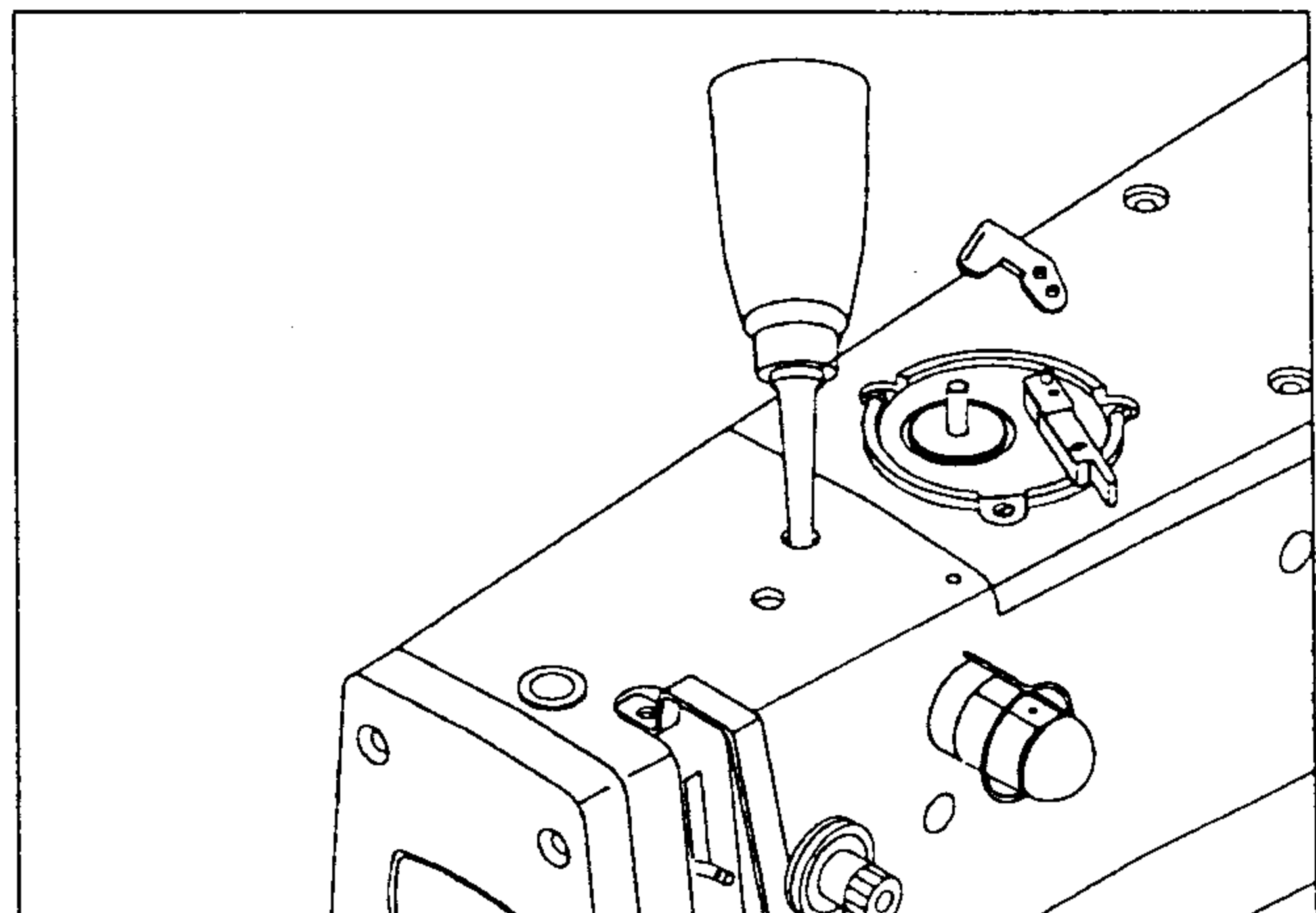

[Fig. 23]

- D. Open the hook cover and supply oil till the shuttle race ring is surrounded by oil.
Put the hook cover back on after finishing.

[Caution]
For safety, keep the hook cover covere during operating.

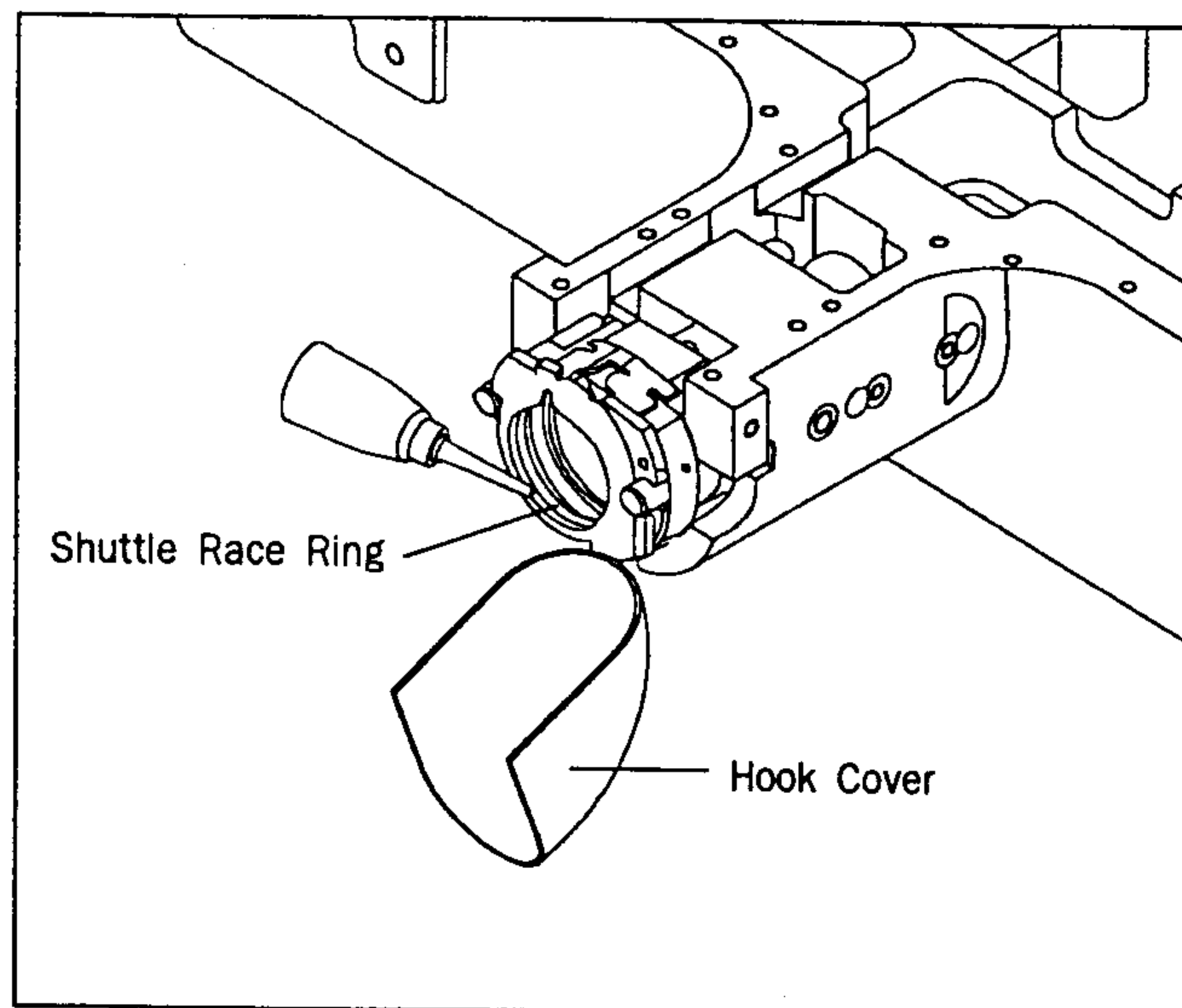

[Fig. 24]

- E. Supply silicon oil into the silicon oil tank which is installed on the right side of the arm.

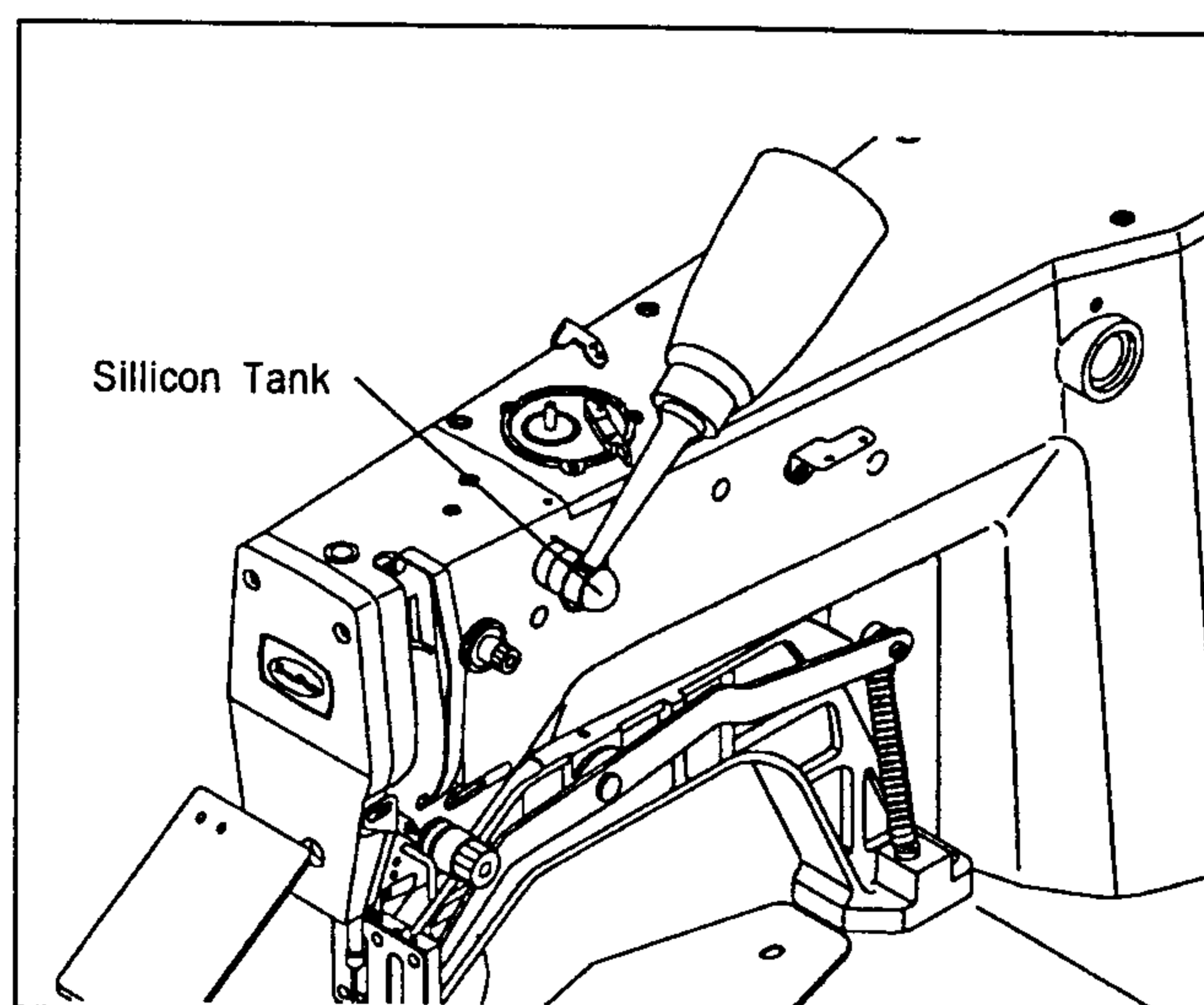

[Fig. 25]

2) How to install the needle bar

Unfasten the needle fixing screw on the needle bar.
Then, with the needle groove facing forward, push the needle until the upper end touches the needle hole of the needle bar. Fix the needle in with the needle fixing screw.

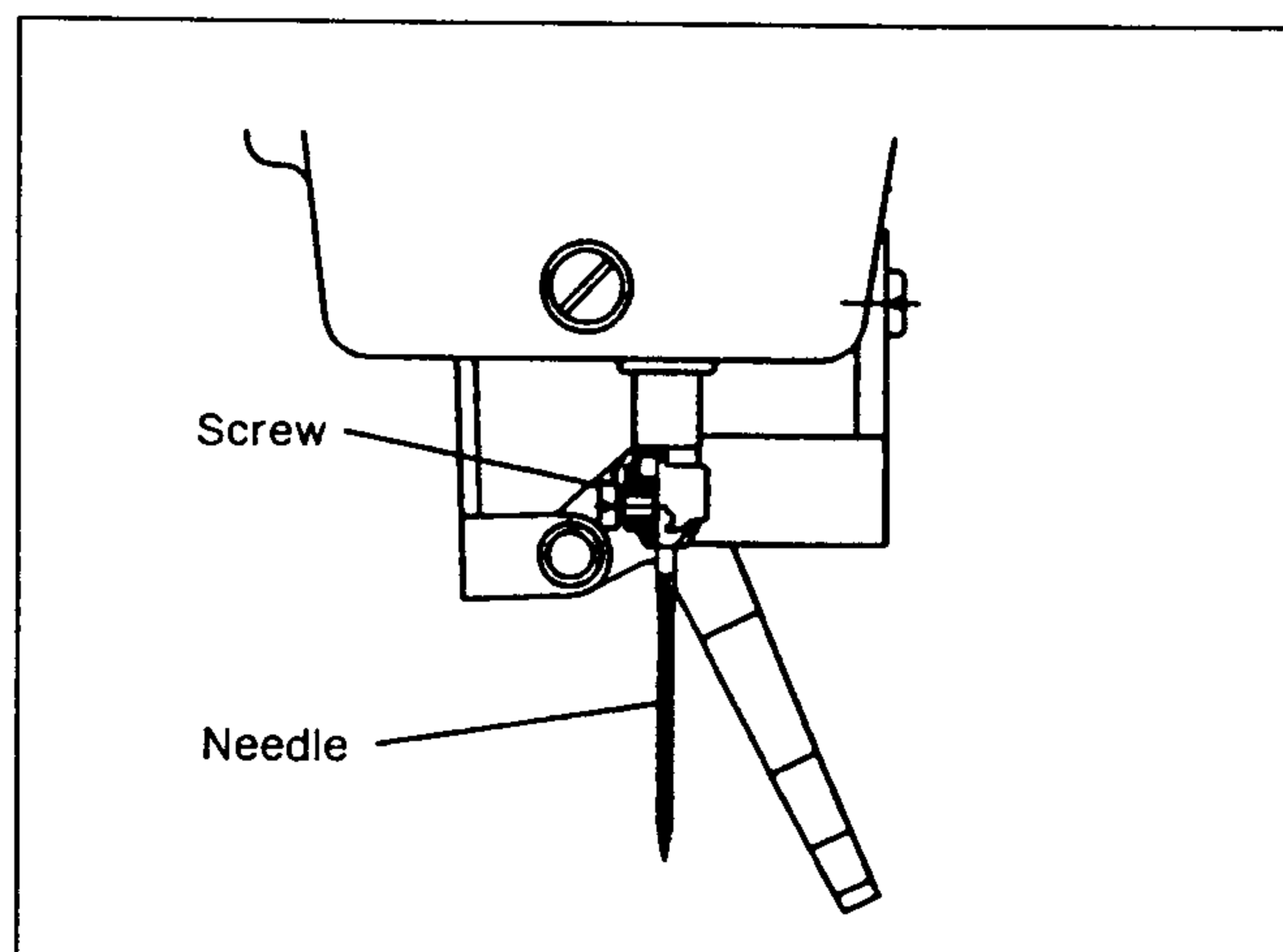

[Fig. 26]

3) How to thread the upper thread

- A. Place the take up lever on the highest position, then hang thread as seen in the figure.
 In case of thread guide of needle bar, hang the thread for thick materials as seen in the figure ①, and hang the thread for thin and general materials as seen in the figure ②.

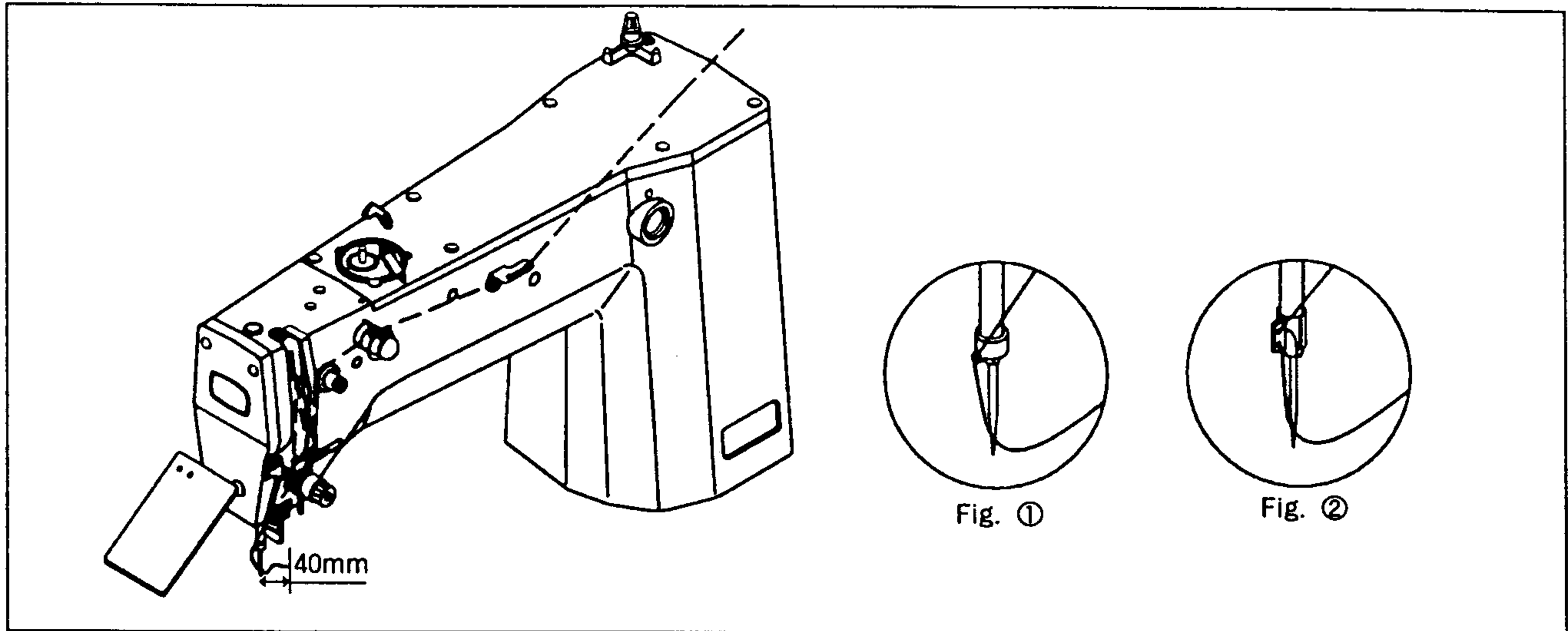

[Fig. 27]

4) Threading the lower thread

- A. Insert bobbin ① into bobbin case ② as shown in the picture.

[CAUTION]
 Insert the bobbin to turn clockwise when seen from behind the bobbin case

- B. After setting the lower thread through the crack of the bobbin case, insert the thread through thread hole ③.
 C. Adjust the lower thread to hang 25mm out of thread hole ③.

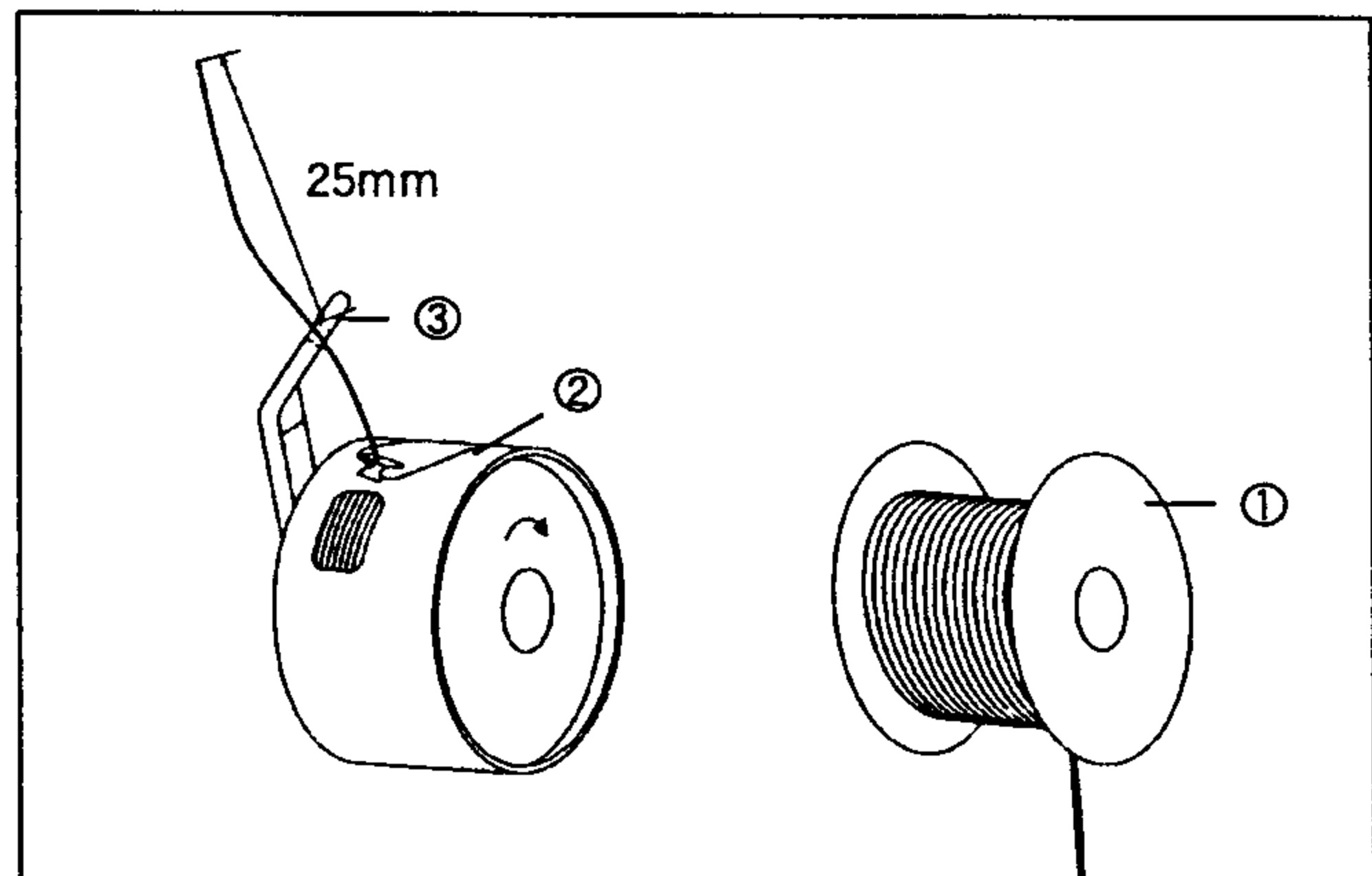

[Fig. 28]

5) How to take the bobbin case on and off

Opening the hook cover, hold the knob ① of bobbin case and push into the shuttle until sounding.

[Caution]
 If you start operating the machine when bobbin case is not perfectly installed, thread can be tangled or the bobbin case would be protruded.

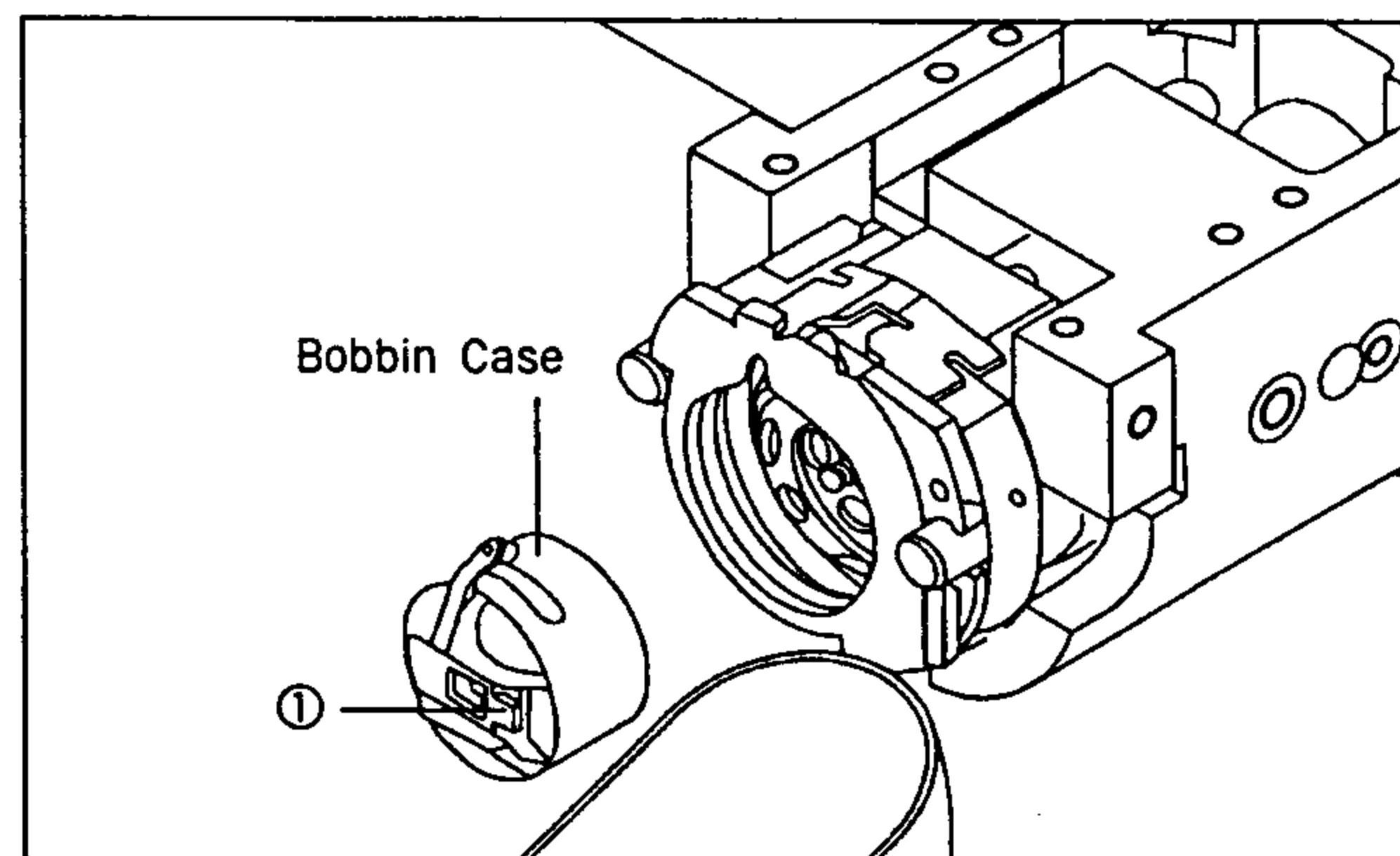

[Fig. 29]

6) How to adjust the tension of the upper thread and the lower thread

A. Adjusting the Tension of the Upper Thread

When the tension adjusting nuts ③ and ④, of thread tension adjusting unit ① and sub-tension adjusting unit ②, are turned clockwise the upper thread is tightened. And loosens when turned the other way around.

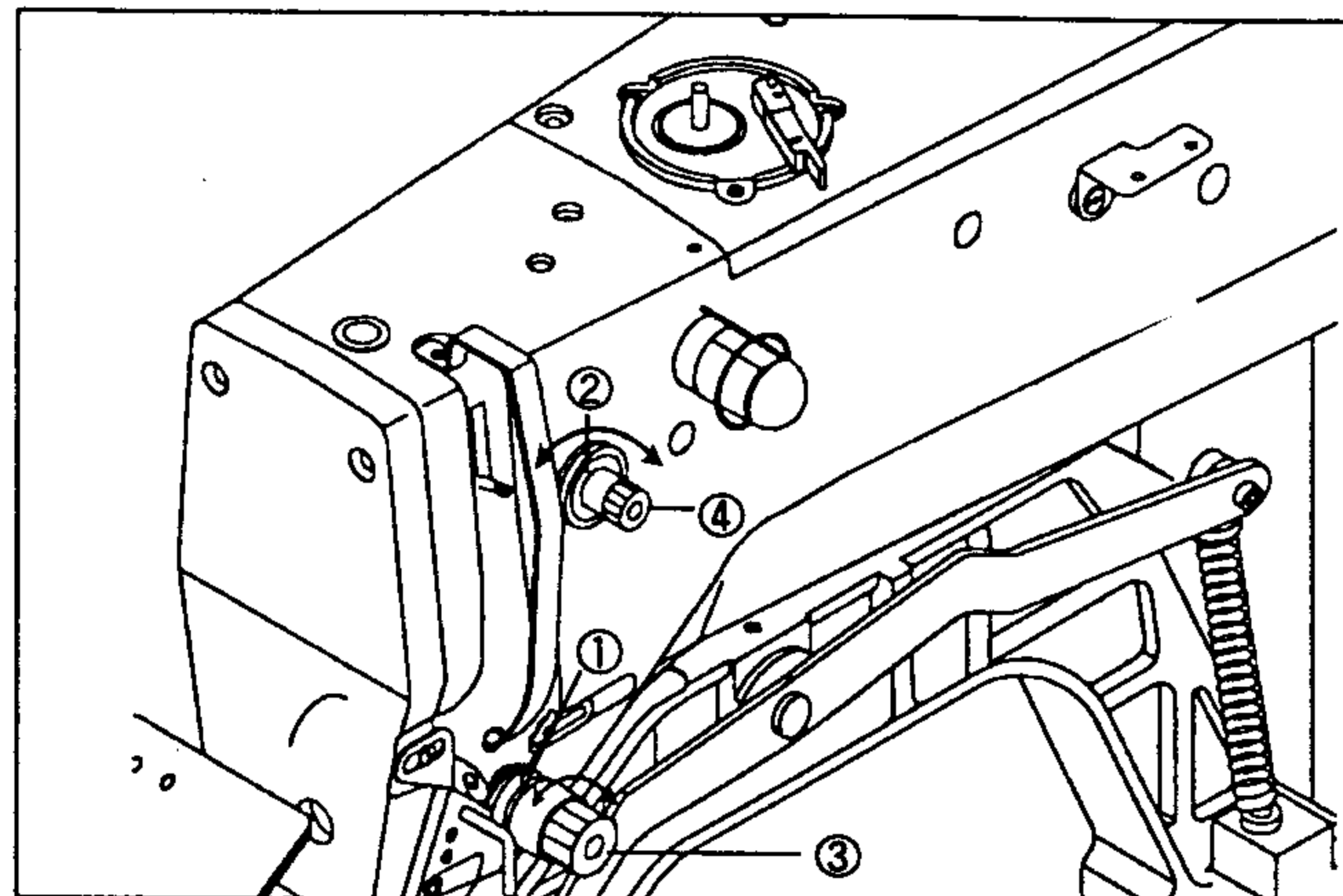

[Fig. 30]

B. Adjusting the Tension of the Lower Thread

The lower thread becomes tight when tension adjusting screw ① is turned clockwise, as shown in the picture. When the screw is turned the other way around the lower thread is loosened.

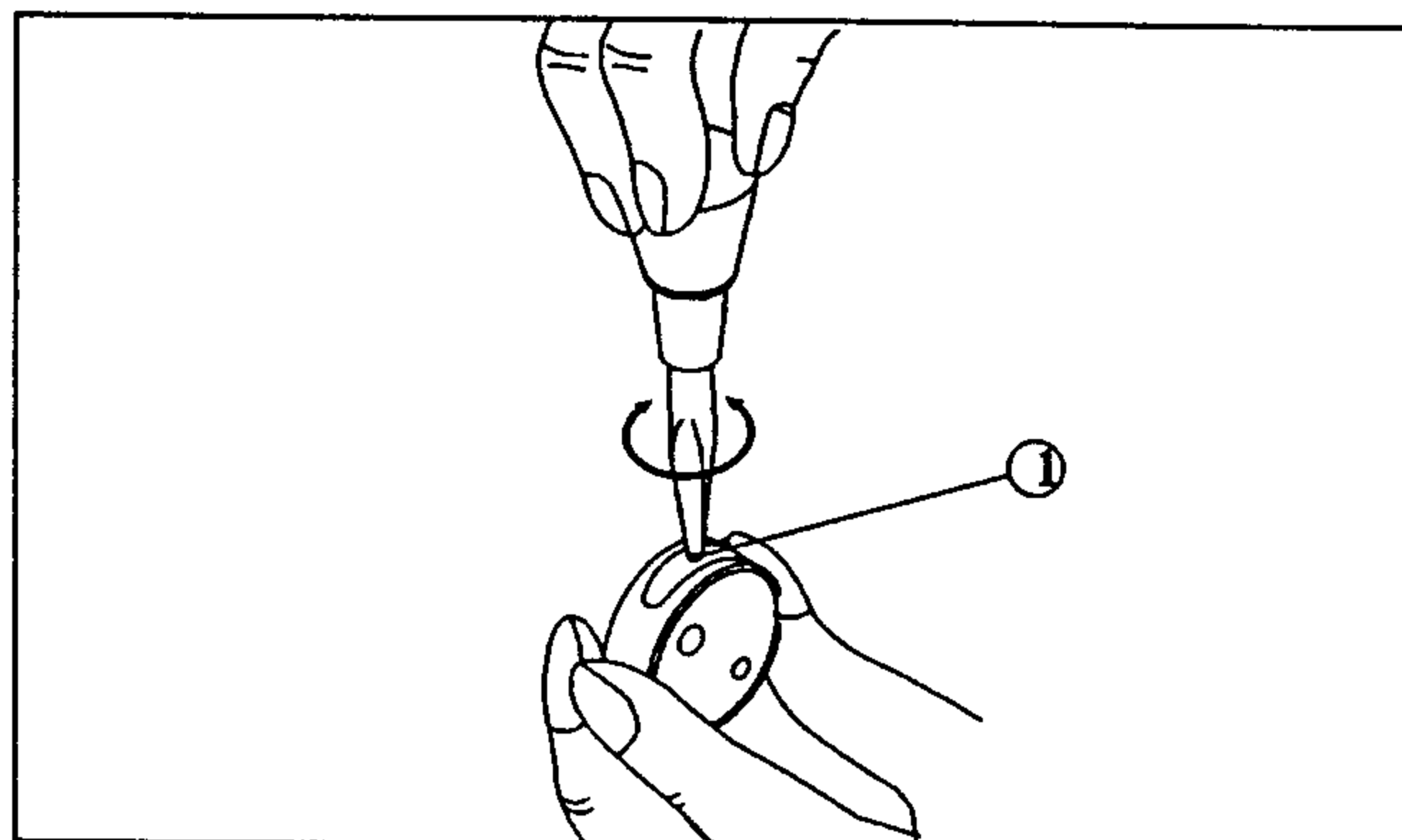

[Fig. 31]

7) How to wind the lower thread

A. Press **SELECT** on operation box and select  WINDER

B. Insert the bobbin into the thread winder drive shaft ② on thread winder base ①, attached to the upper cap.

C. Adhere the bobbin winder lever ③ closely to a bobbin, then let the machine run by pressing pedal.

D. After the bobbin winder lever takes off from a bobbin, cut the thread of bobbin by using bobbin winder knife ④.

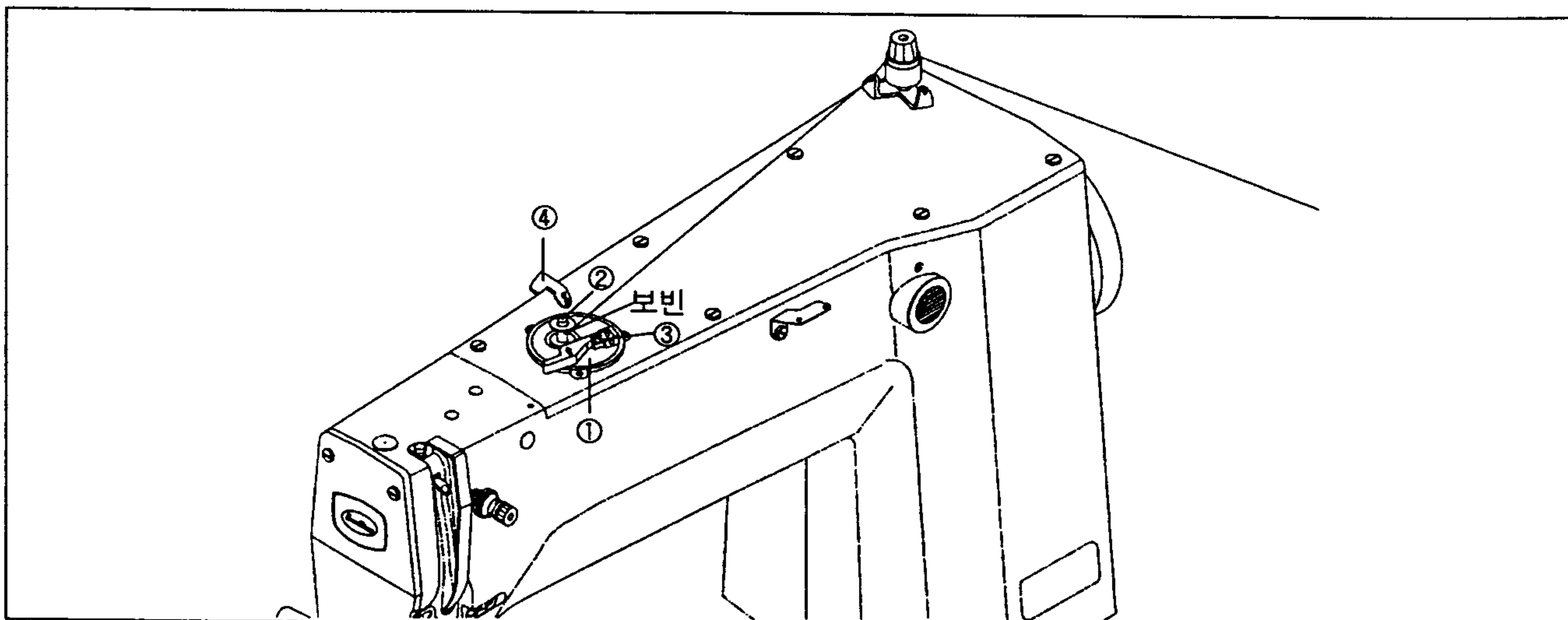

[Fig. 32]

8) How to operate a pedal

- A. Install a pedal switch in the proper position for the convenience of work.
- B. If you step on pedal one time, the presser foot descends, and if take off your feet from the pedal, it ascends.
- C. If you step on twice the pedal switch after stepping on it one time, the sewing starts, and after finishing it, the presser foot ascends.

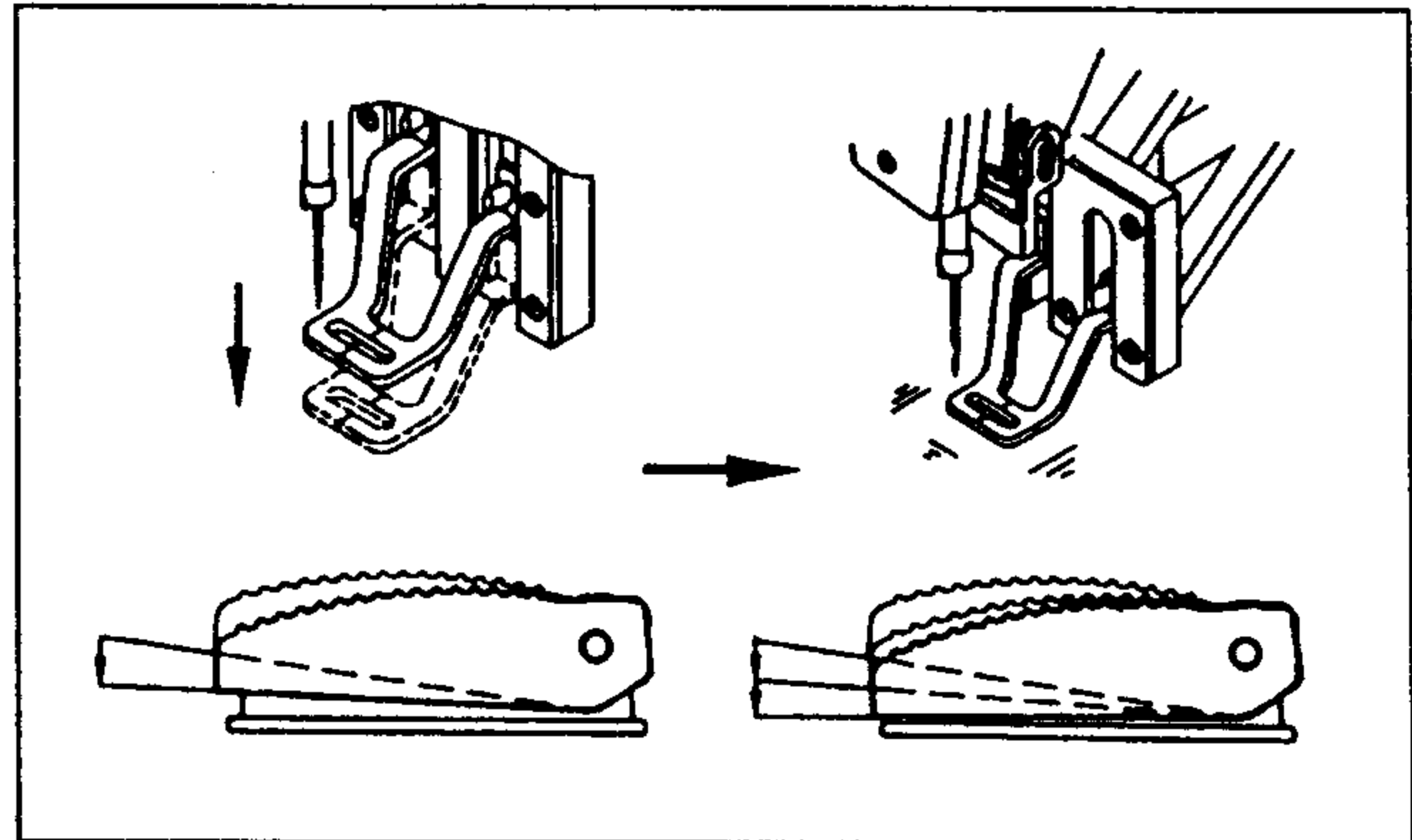

[Fig. 33]

9) Pedal Operation Method (for HA type)

- A. SPS/A-B1201 HA-20 (Serial type of presser foot driving)
It is same to the pedal operation method of electronic Bataek type in Article 8).
- B. SPS/A-B1201 H-22 (Separate Type of Presser Foot Driving)
 - ① Two footplates of pedal switch is provided and if you step on the right pedal, the right presser foot goes downward and if you step on again, the right presser foot goes upward.
 - ② Upon stepping on the left pedal, the left presser foot goes downward and if you step off, it goes upward again.
 - ③ After stepping on the pedal one-step and then continues to step on two steps, sewing is started and if sewing ends, the presser foot goes upward automatically.
 - ④ Operating process of the left and the right presser foot is available only by parameter selection. Refer to electronically controlled part page 18 on changing method.

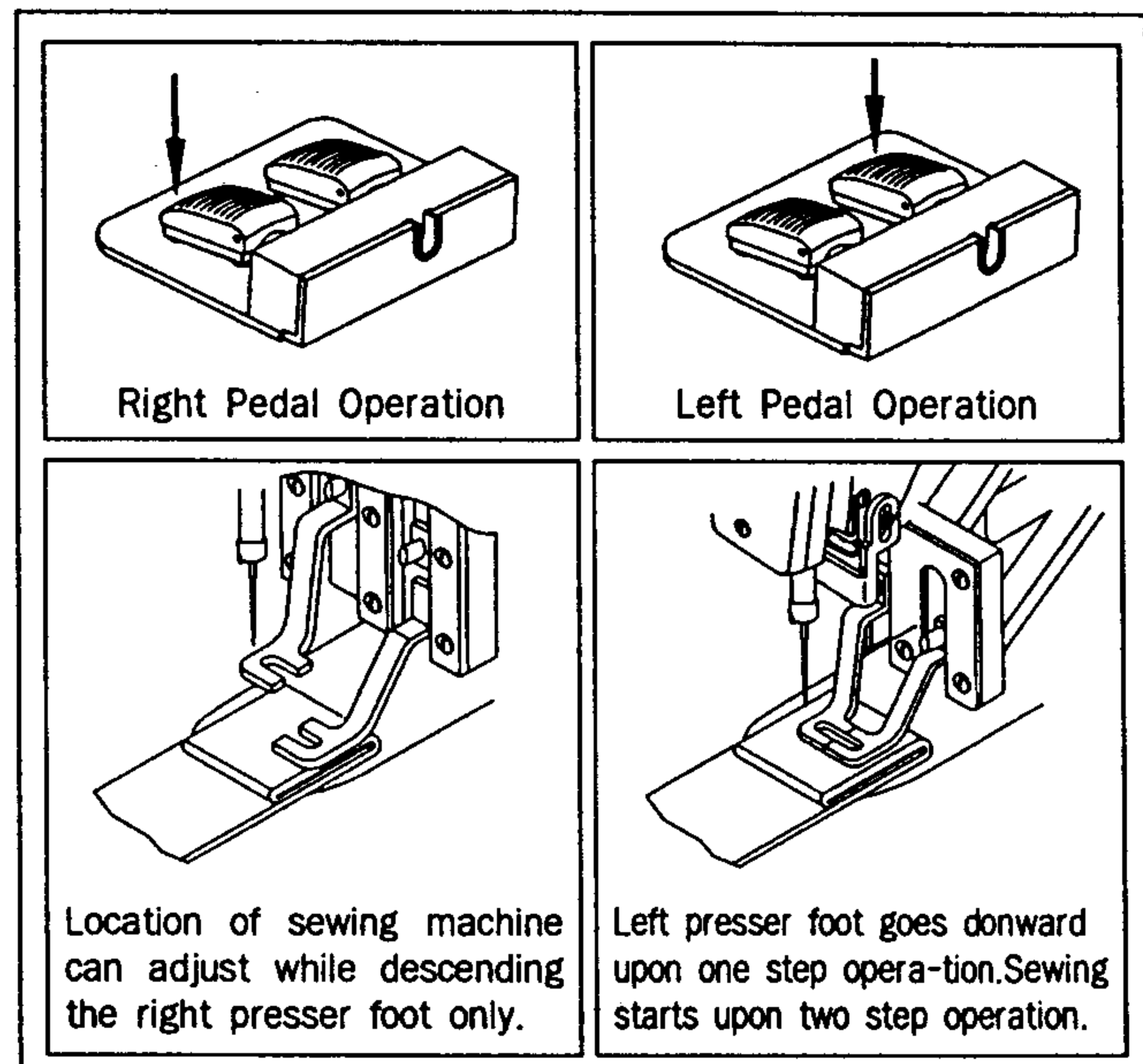

[Fig. 34]

10) Disposing the waste oil

When the oil receiving oiler at the bottom of the table is full, take it off to empty.

[Caution]

Spread out some fabrics or papers on the floor when you attach or remove the oil receiving container.

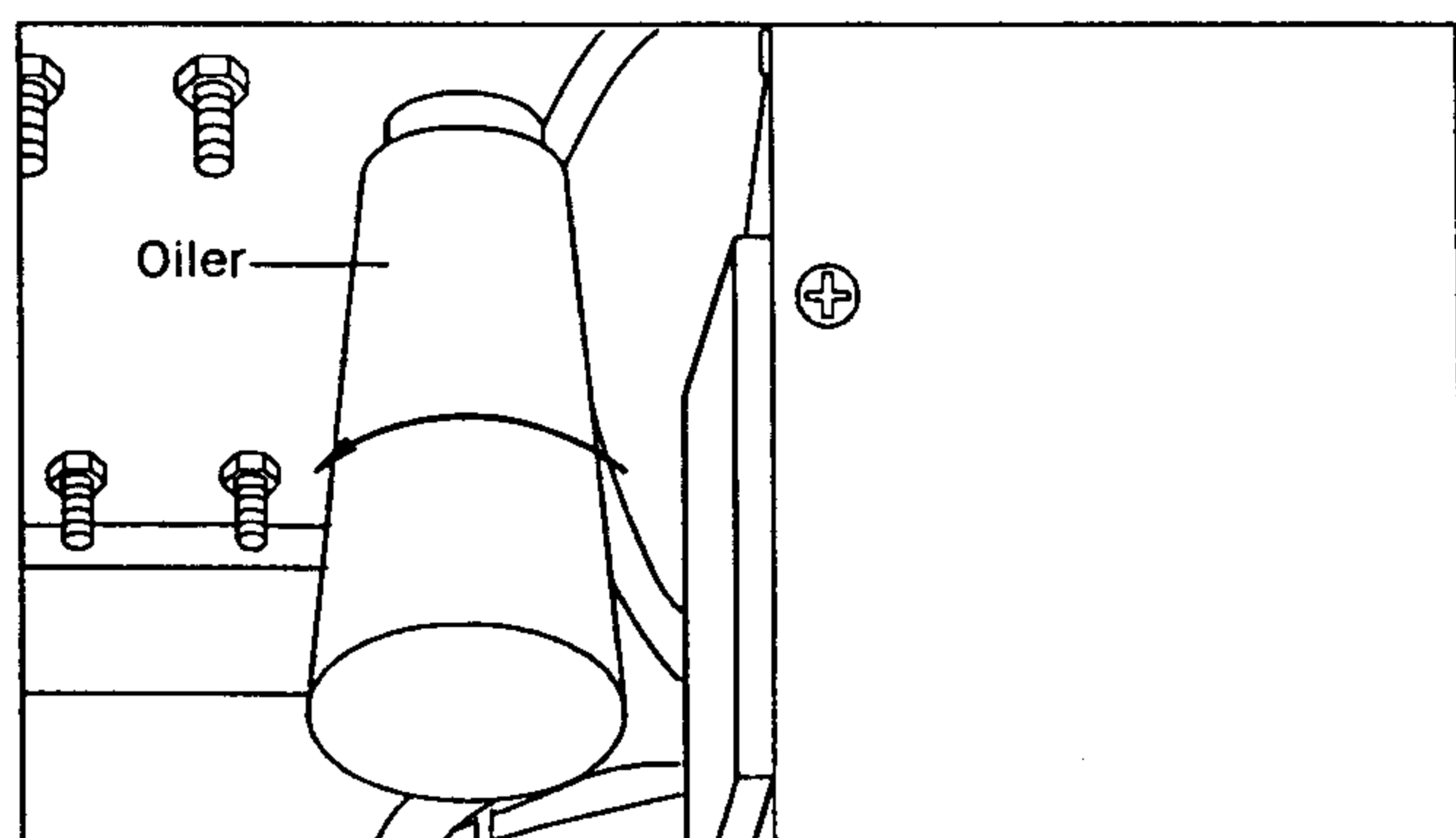

[Fig. 35]

11) Compressed Air Input and Air Pressure Adjusting Method(HA Type)

[Note] Please Operate under power-off status for prevention of safety accident.

A. Please connect quick joint socket ① that pressed air was connected to the quick joint plug ② attached to the table.

B. Open the finger valve ③ and input the pressed air.

[Reference]

If you close the finger valve after you use it, automatically discharge the remained air and the remained pressure is indicated as 0 Mpa(0 kgf/cm²).

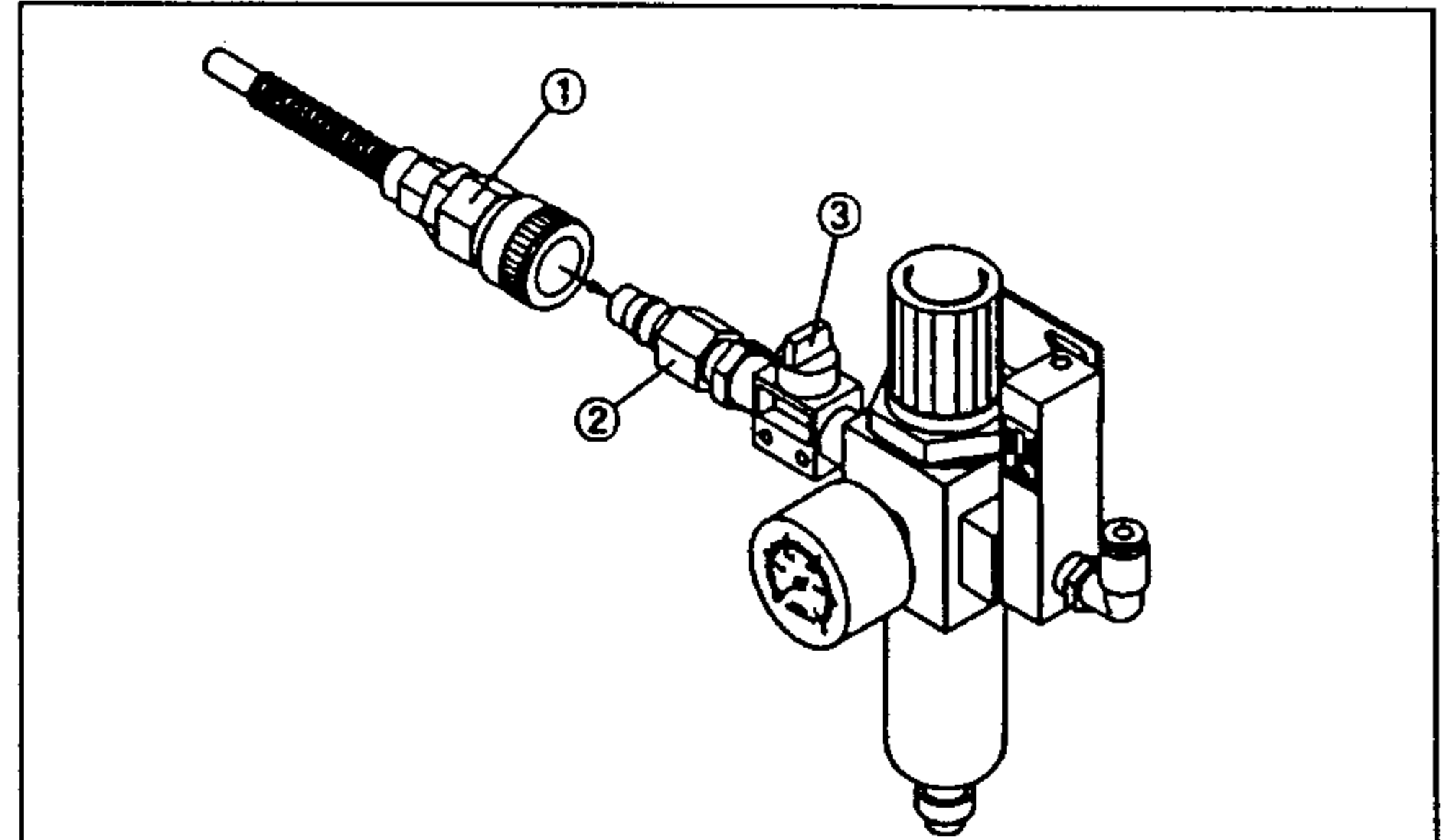

[Fig. 36]

C. After pulling the adjusting handle located on the upper part of filter regulator as shown in the right figure, if you turn it to clockwise direction, the pressure rise and if you turn it to counter clockwise direction, the pressure drops. Therefore, after adjusting to the proper pressure 0.49~0.54Mpa (5~5.5kgf/cm²) indicated on the pressure gauge, press the adjusting handle to the original location and fix it.

[Note]

If the air pressure drops while using it (less than 4 kgf/cm²), it shall be indicated as "error" and operation of the machine shall stop. [Er07]

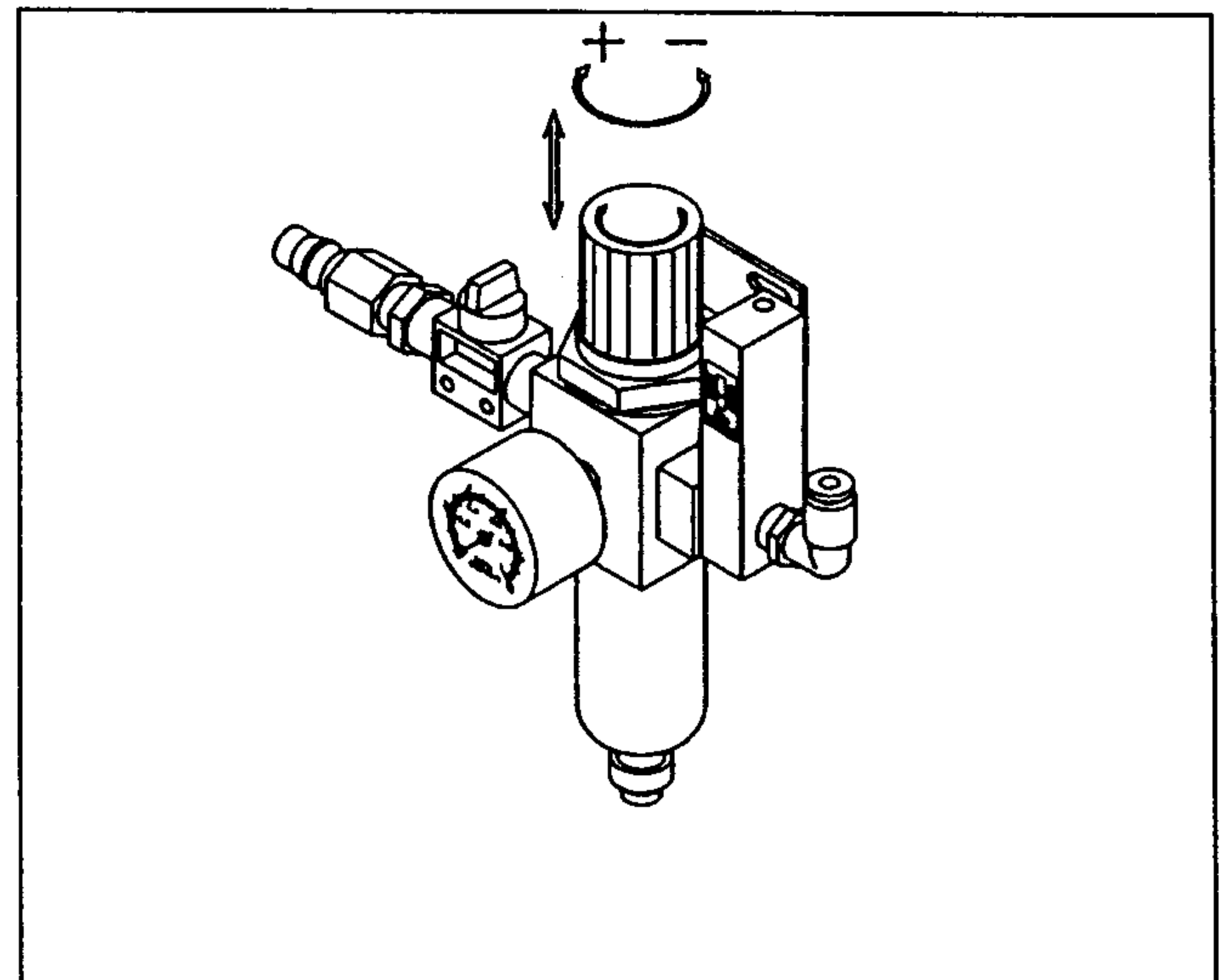

[Fig. 37]

12) Adjusting Method of Upper Thread Holding Device (Option)

A. Please confirm if upper thread holder pin cylinder knuckle ① and cap ② are located in the center of upper thread passage.

B. If they are not located in the center, unfasten two pieces of joint screw ④ of upper thread holder pin cylinder bracket ③ and adjust to be located in the center. Then unfasten two joint screw ④ and adjust to be located in the center and fasten joint screw ④ tightly.

C. Standard distance between end of knuckle cap ② and ARM ⑤ should be 4mm.

D. In order to adjust this, unfasten two pin cylinder nut ⑥ and adjust distance of front and back. Then if adjustment is finished, fasten two nut ⑥ tightly.

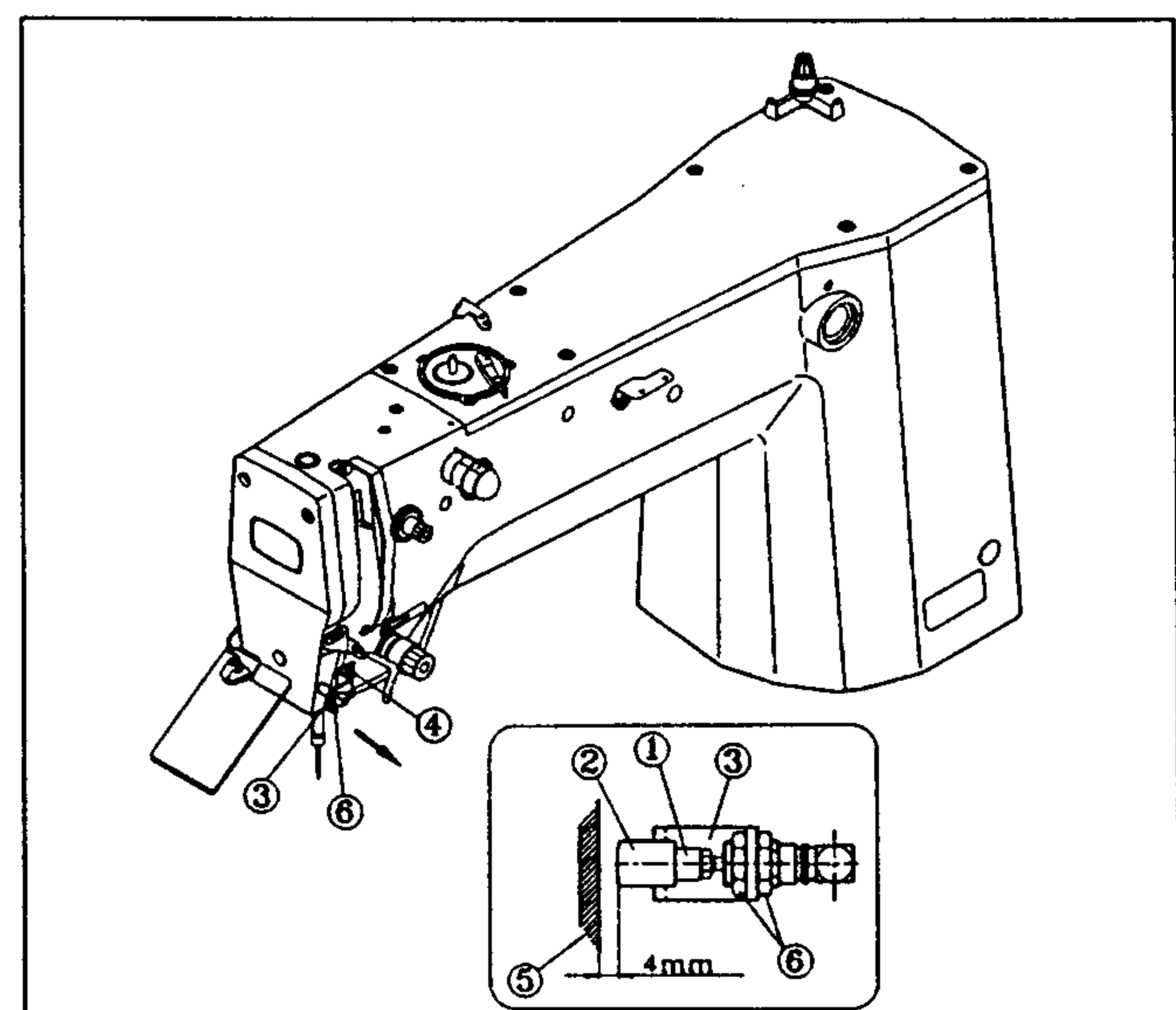

[Fig. 38]

6

HOW TO REPAIR THE MACHINE

Caution

The machine is set to be the best condition at the factory. Do not make any discrete adjustments on the machine and replace genuine parts approved by the company only.

1) Adjusting the height of the needle bar

When the needle bar is at its lowest position, unfasten the needle bar holder screw ①. Adjust the desired height by making the specified upper carving line fit in with the needle bar bushing. Then, tighten the needle bar holder screw back on firmly.

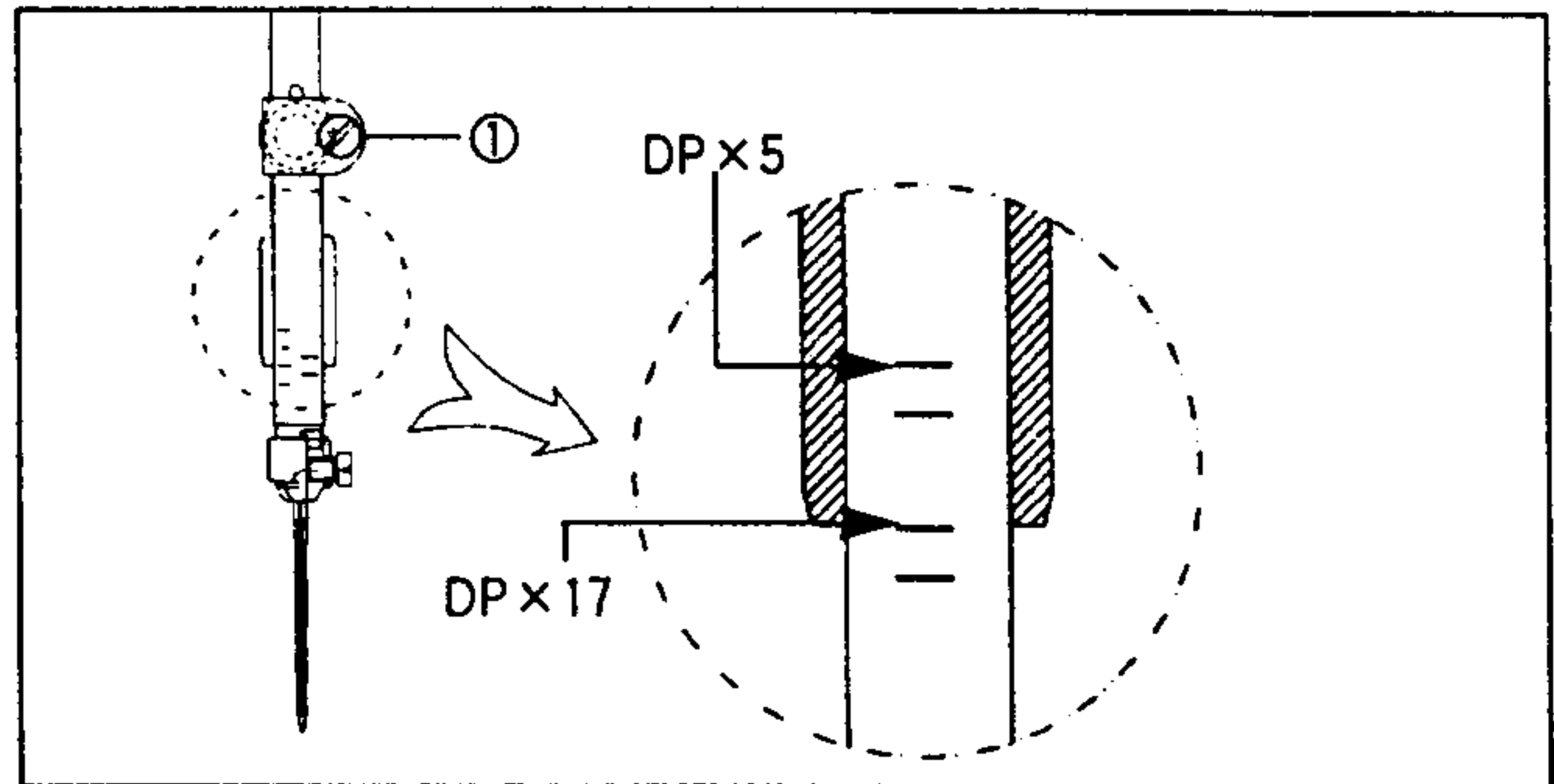

[Fig. 39]

2) Adjusting the needle and the shuttle

A. Have the lower carving line for the needle that is applied when the needle bar goes up fit in with the lower side of the needle bar bushing as shown in the picture.

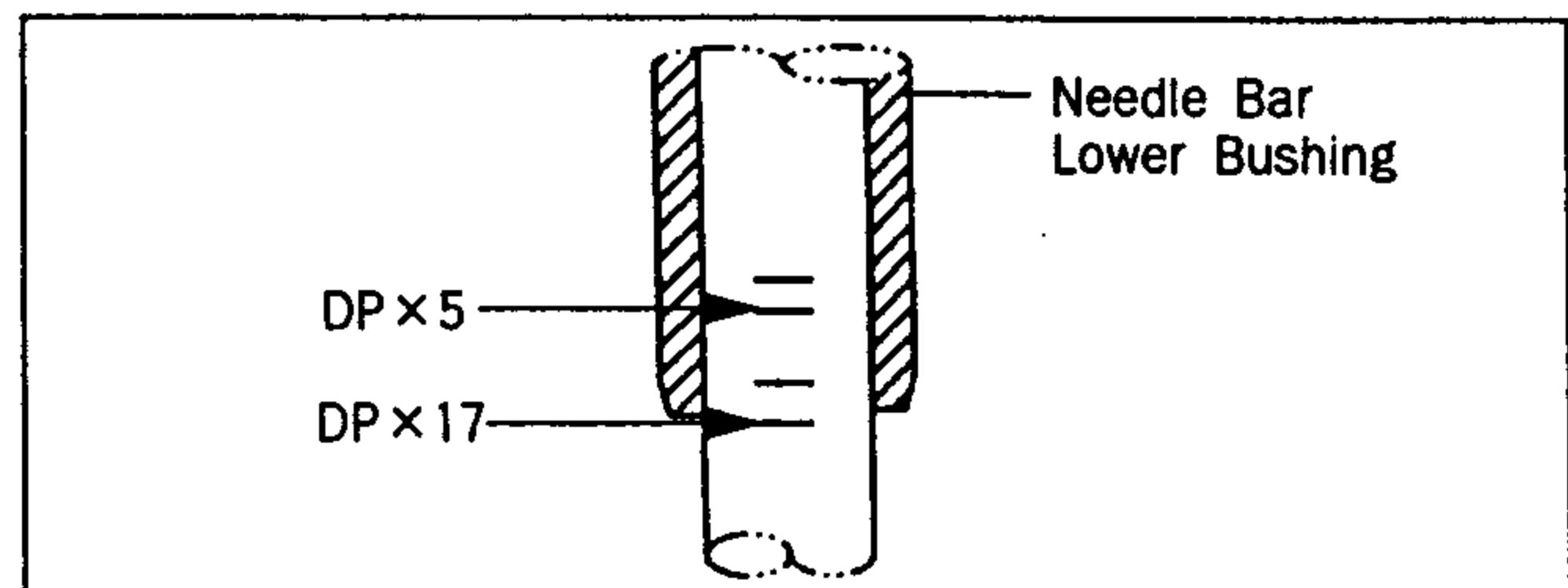

[Fig. 40]

- B. After unfastening the shuttle drive screw ①, open the inner hook pressure bar ② left to right and remove the shuttle Race ring ③ from the (large) shuttle ④.
- C. Make the shuttle hook point ① accord with the center of the needle. And make the needle and the front face of the shuttle drive ② connect each other to prevent the needle from curving. Then, tighten the drive screw ① firmly.
- D. After unfastening the (large) shuttle screw ⑤, turn the large hook adjustment shaft ⑥ to the left to right and adjust the (large) shuttle ④ so that the needle and the shuttle hook point ① is 0.05~0.1mm apart from each other.
- E. After adjusting the (large) shuttle ④ in place, adjust the rotary direction of the (large) shuttle ④ so the needle and the (large) shuttle ④ is 7.5mm apart from each other. Then, tighten the (large) shuttle screw ①.

[Caution]

For safety, make sure all the screws are tightened firmly after adjusting the (large) shuttle.

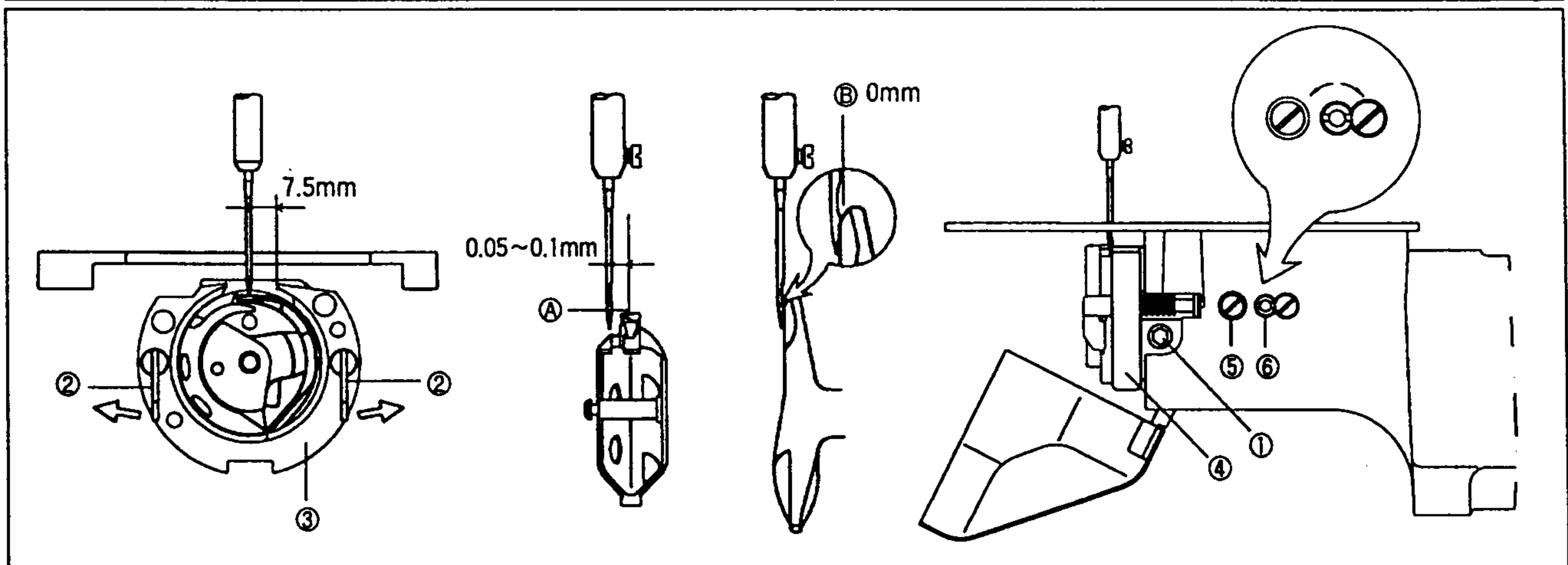

[Fig. 41]

3) Adjusting the lower shaft gear and the rocking shaft gear

- A. Unfasten screws ① and ② ③.
- B. While having the upper shaft turning, move the rocking shaft gear in the direction of the arrow to the position where it will move easily without load.

[Caution]

The machine may not operate when the rocking shaft gear is not in the right position.

- C. Have the oscillator shaft collar(right) stick to the bed surface ④, and then tighten the collar screw.
- D. Turn the oscillator shaft collar(right), still sticking to the bed surface ④, in the direction of the arrow and make adjustments so the end of the shuttle drive will rotate smoothly with the backlash of under 0.1mm.

[Caution]

If there is too much backlash the machine may make more noise than usual during operation. And if there is not enough backlash, the machine may not operate.

- E. Tighten screw ① and ③ back on firmly.

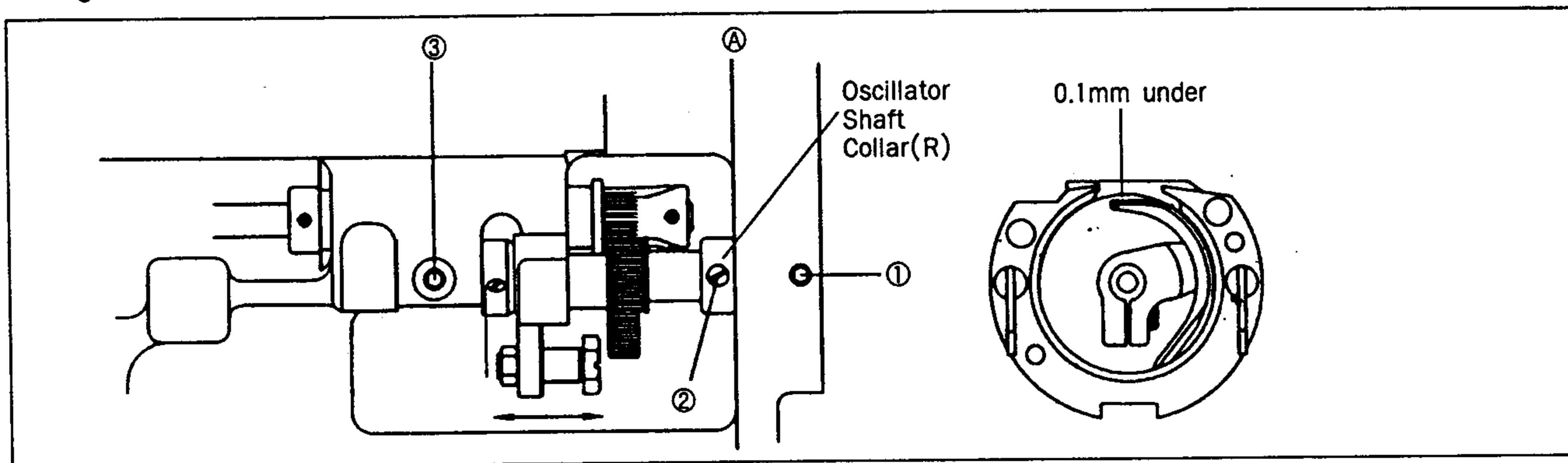

[Fig. 42]

4) Adjusting the position of shuttle upper spring

After removing the lower feed plate and the needle plate from the machine, unfasten the screw of the shuttle upper spring. Then, adjust the shuttle upper spring so that the backside of the needle and comes to point ④ in the vertical direction, and the center of the needle will come to the middle of interval ⑤ horizontally. After the adjustment is done, tighten the screw back on firmly.

[Caution]

The thread may be disconnected or the thread strand may be unfastened if there are scratches or if the surface is rough around the Shuttle upper spring. Always check the surface of the spring before operating the machine.

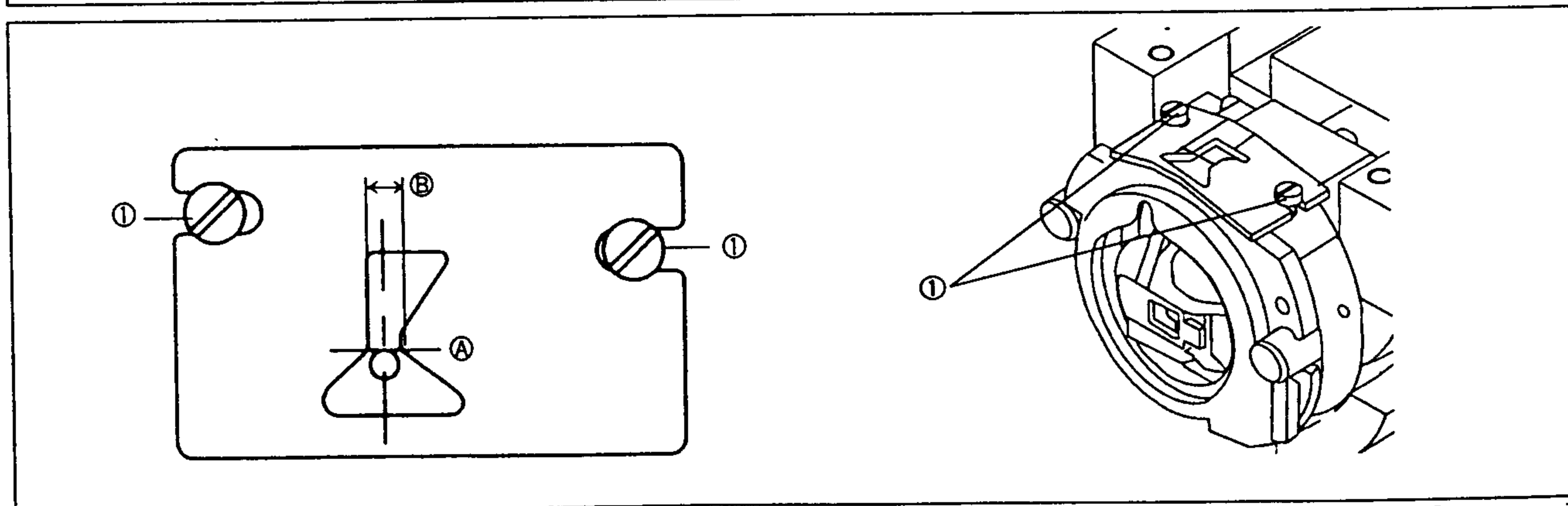

[Fig. 43]

5) Adjusting the height of work clamp foot

After unfastening the lift lever adjusting plate bolt ② on the right and left side of feed bracket ①, if you lift the adjusting plate ③ up to the A direction, the height of work clamp foot ④ becomes lower, and if you lower it to the B direction, the height of presser foot ④ becomes to set up highly. After finishing the adjustment of work clamp foot ④ height, fix the lift lever adjusting plate bolt ② tightly. (The maximum work clamp lift amount is 17mm from the Top to the needle plate).

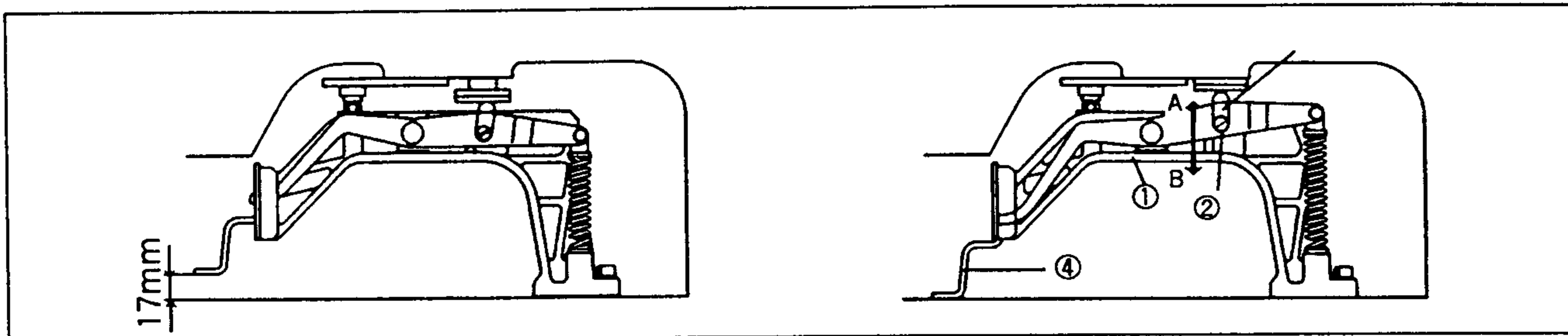

[Fig. 44]

[Caution]

After finishing the adjustment of work clamp foot, fasten each bolt perfectl.

B. In case of Air Pressure (HA type)

Unfasten the cylinder knuckle joint nut ③ attached to the left and the right cylinder ② of feed bracket ①, and take up the cylinder knuckle ⑤ toward A direction by rotating the cylinder axis ④, then the height of presser foot ⑥ becomes low and the height of the presser foot ⑥ is set high. When the height adjusting of presser foot is completed, fix the cylinder knuckle joint nut tightly.

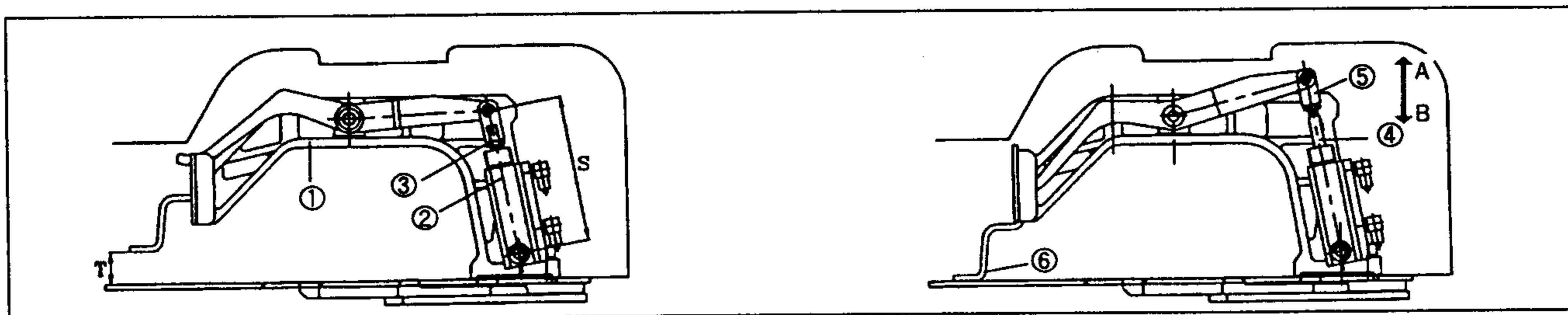

[Fig. 45]

T	14	15	16	17	18
S	85.4	84.5	83.7	82.8	82.0

[Note]

When you should adjust the rise of presser foot over the maximum value (14mm), please remove the wiper unit.

6) Adjusting the parts of thread release

A. How to Set the Thread release Notch Place the notch so that the right side of the slot of the thread release notch ① touches circumference of the notch screw ②, and then fix with a screw.

[Caution]

The remaining amount of thread may not be enough or not be regular and the thread may be unfastened from the needle if the notch is not set in the right position.

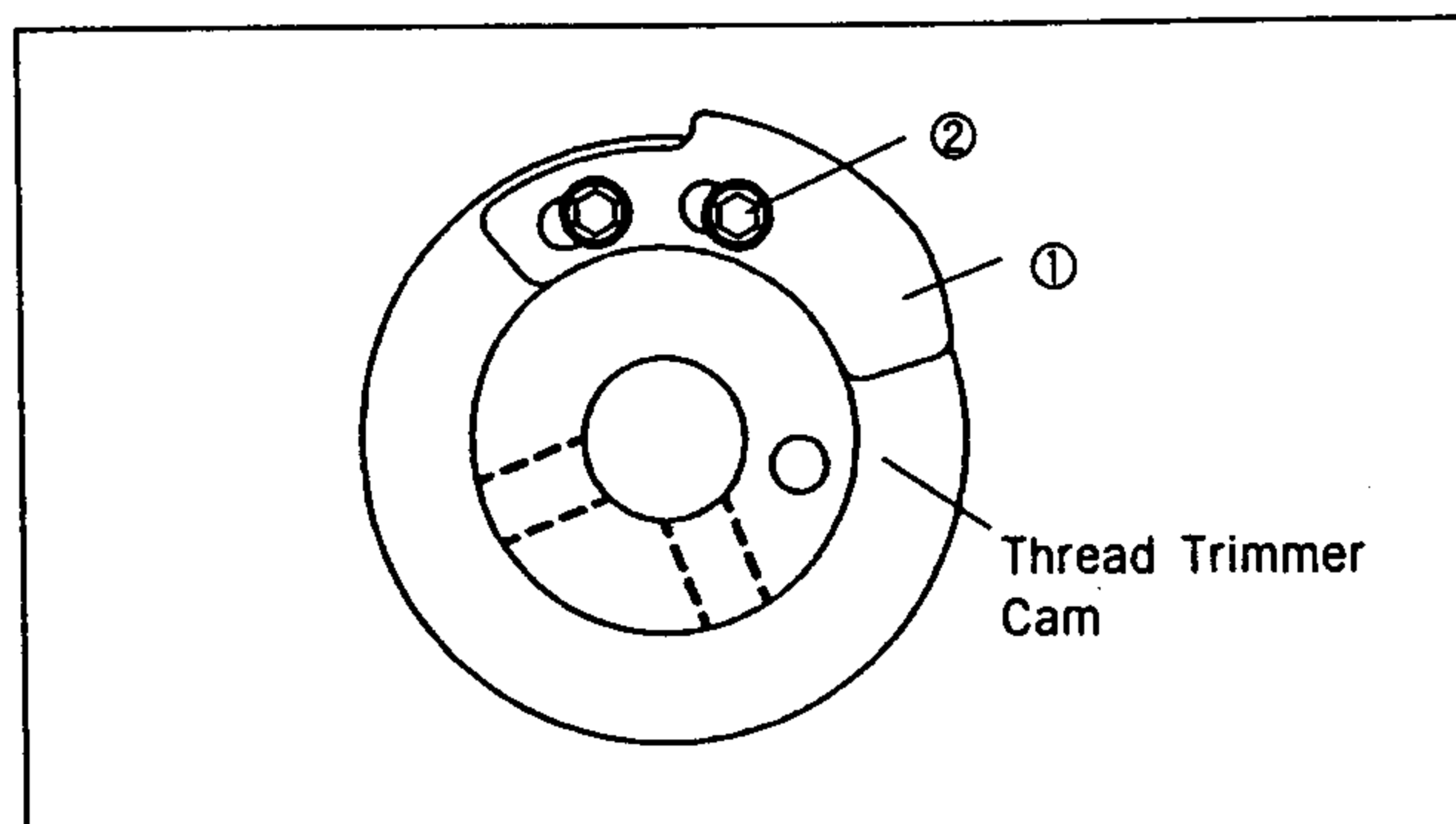

[Fig. 46]

B. How to Set the Thread Release Stopper

- Ⓐ Remove the thread release return spring.
- Ⓑ After unfastening the thread release stopper screw, adjust the trimming drive link and the thread release lever pin 0.3mm apart from each other. Then, attach the arm to the thread delay stopper completely. When the thread release stopper is pushed to the right, the space between the trimming drive link and the thread release lever pin is reduced. And it is enlarged when the stopper is pushed to the left.
- Ⓒ Hang on the thread release return spring.

[Caution] Use a tool when removing or attaching the thread delay spring to prevent accidents.

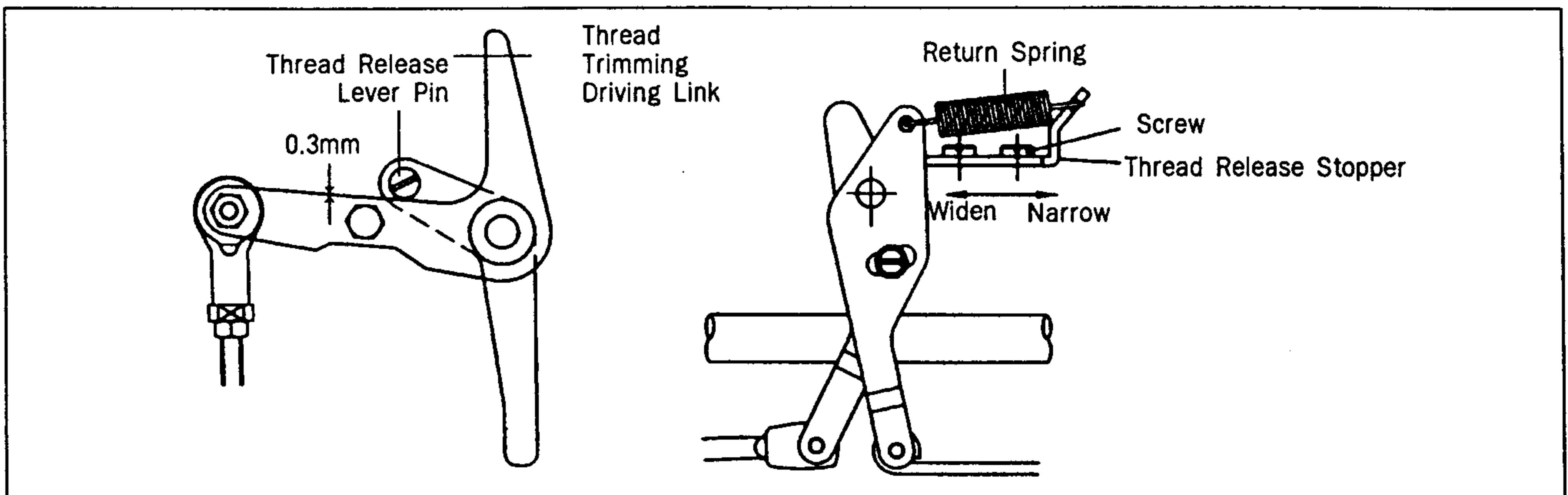

[Fig. 47]

C. How to adjust the opening capacity of the thread guide disk

- Ⓐ Unfasten the thread release adjusting plate screw.
- Ⓑ Open the thread guide disk by operating the trimming devices.
- Ⓒ Adjust the opening capacity to 0.6~0.8mm for normal material and 0.8~1mm for heavy material. To increase the opening capacity, widen the angle between the thread release plate and narrow the angle to reduce the opening capacity.
- Ⓓ Tighten the screw after the adjustment.

[Caution]

If the disk is not opened appropriately, the amount of remaining thread may be not enough or not regular, and the disk may not be closed completely.

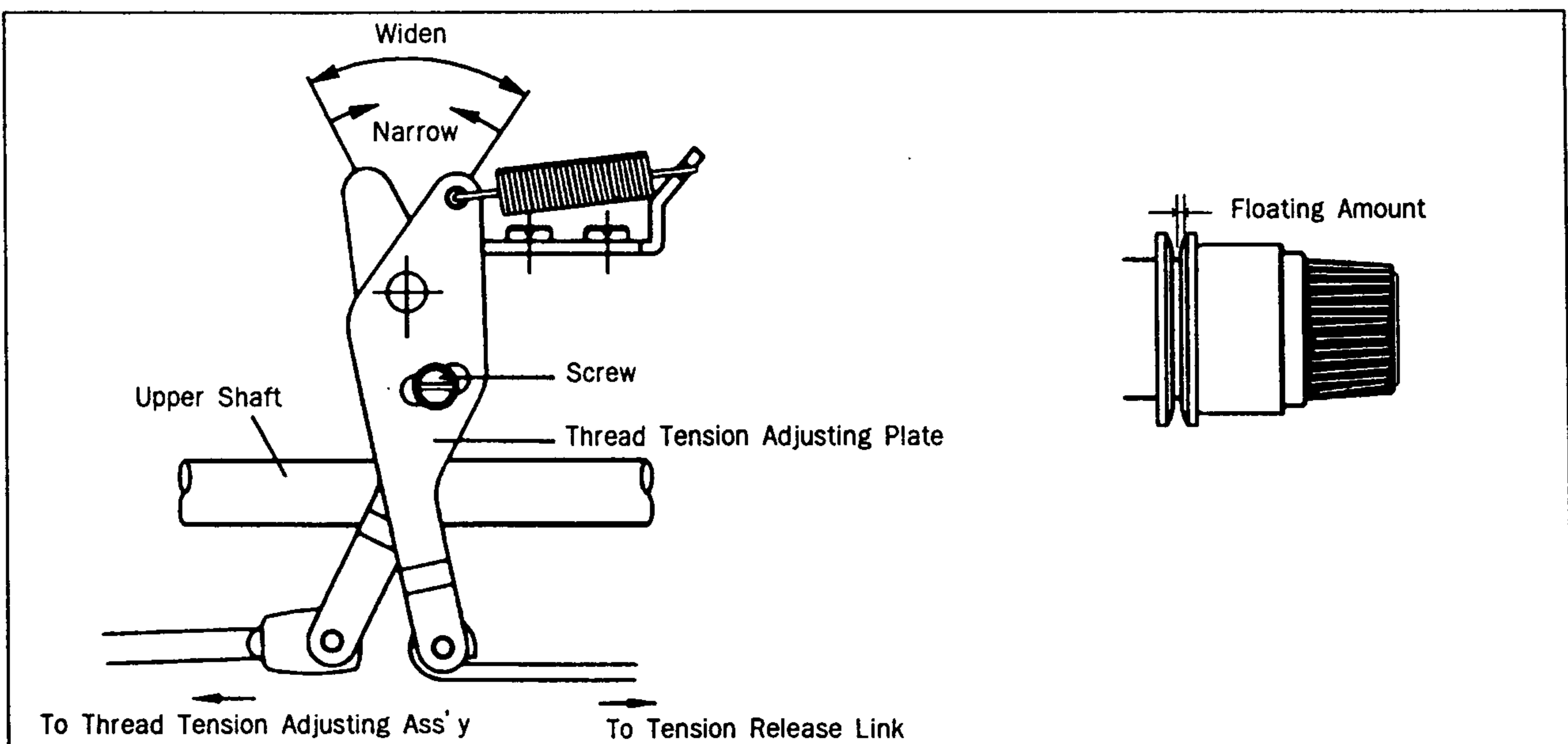

[Fig. 48]

7) Adjusting the parts of wiper

- Ⓐ Unfasten the wiper base plate bolt ②.
- Ⓑ When the wiper and center of needle are on a straight line, adjust the wiper base plate ③ up and down to make the distance between needle plate ① and wiper become 14~15mm, then fasten the bolt ②.
- Ⓒ Unfasten the wiper rod bolt ④.
- Ⓓ When the wiper runs to the maximum, adjust the wiper linkage rod ⑤ up and down to make the center of needle and wiper become 25mm, then fasten the wiper rod bolt ④ tightly.

[Caution]

If the wiper is not placed in the right position, the wiper may collide with the presser foot or needle during the operation, and the wiper may not move properly.

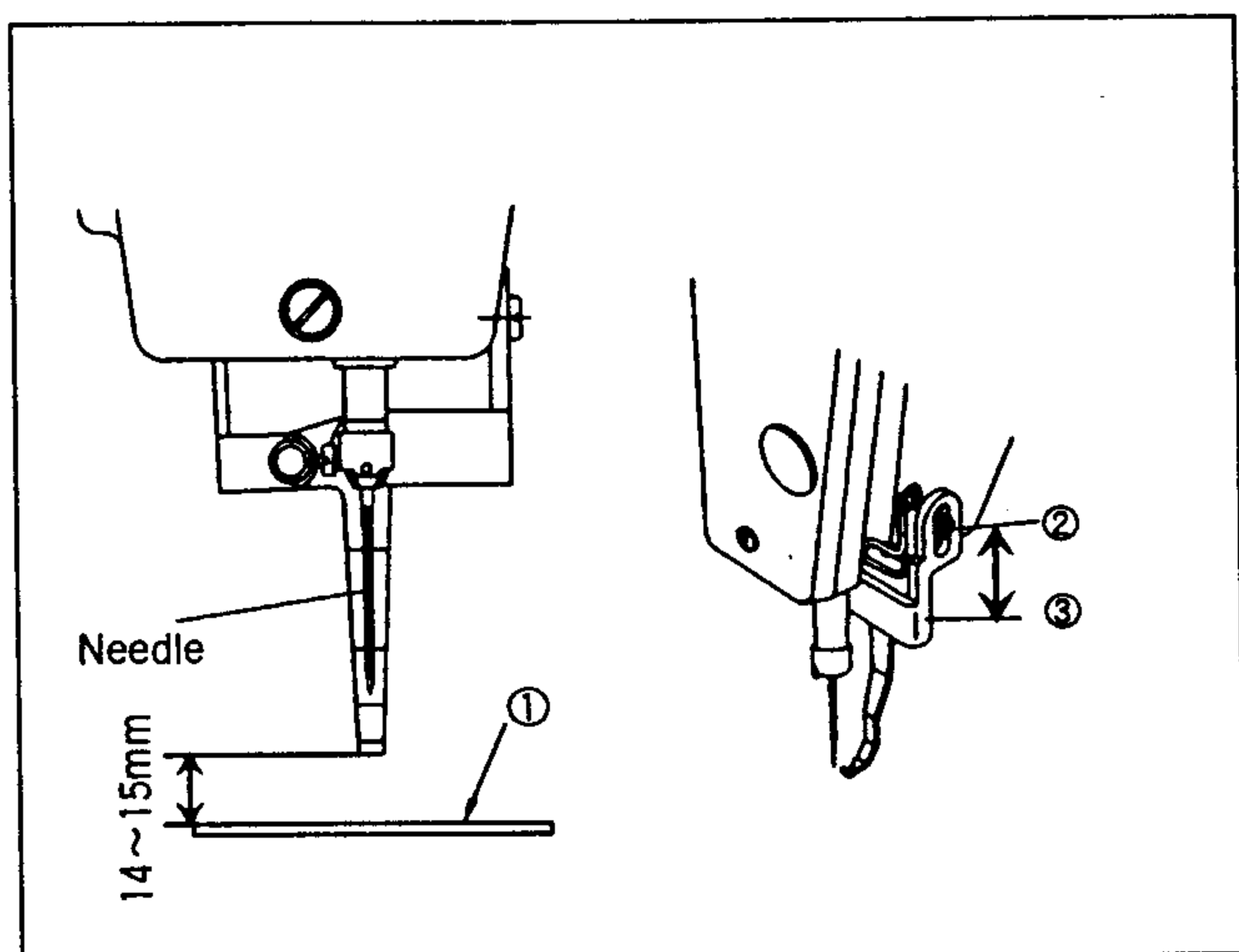

[Fig. 49]

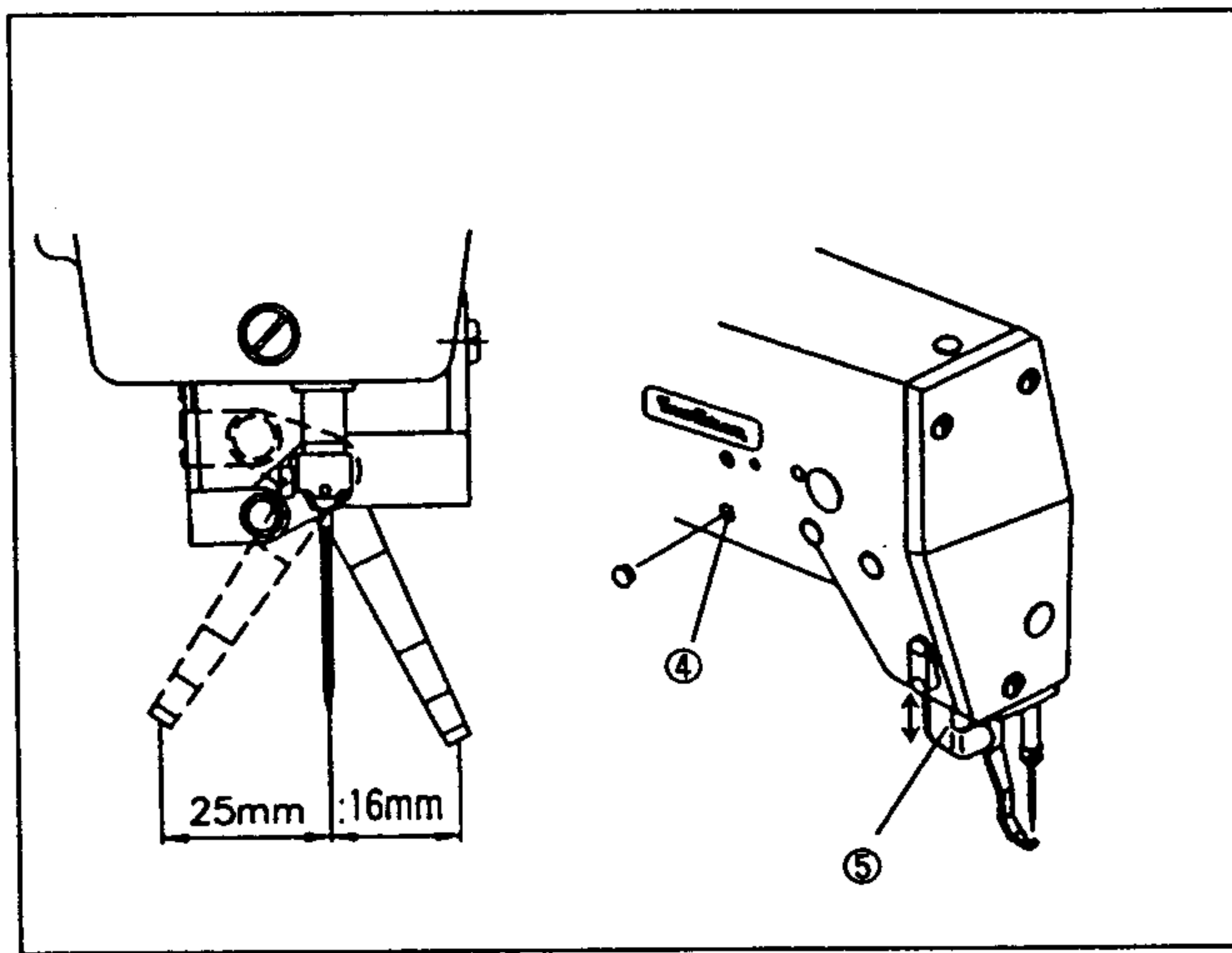

[Fig. 50]

8) Adjusting the parts for trimming

A. Setting the position of the trimming Cam

Set the upper shaft collar and the trimming cam 1.7mm apart from each other and place the trimming cam where the trimming cam carving line accords with the upper shaft carving point. Then, tighten screw ①.

[Caution]

If the trimming cam is not placed in the right position, the trimming operation may not be made correctly or the machine may be lock.

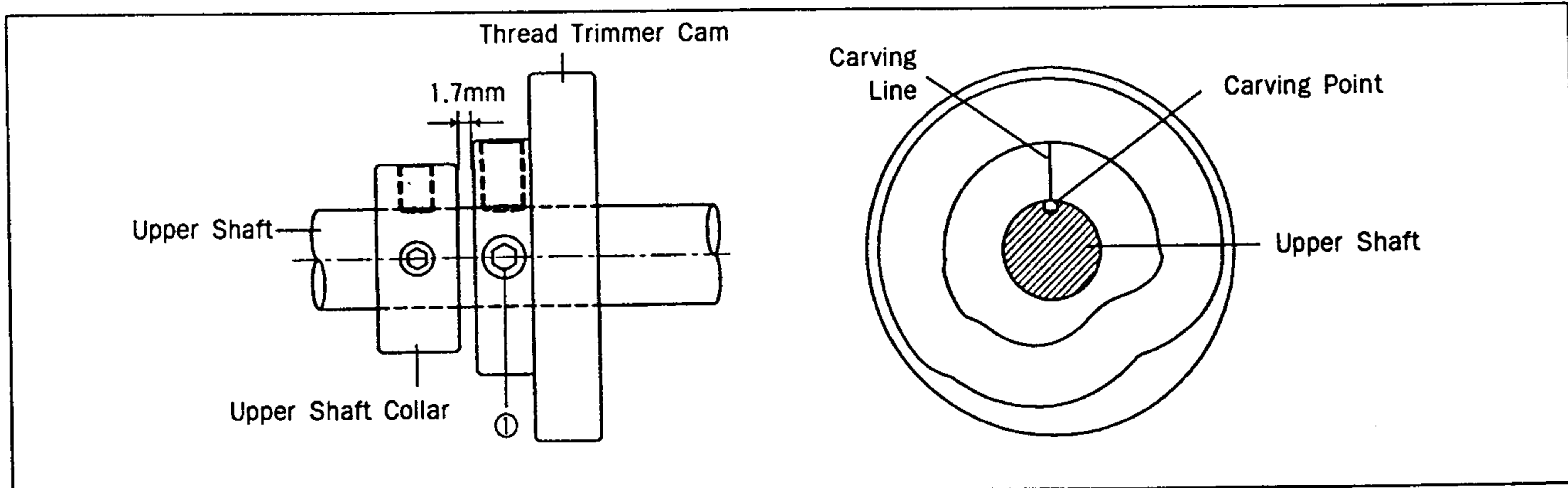

[Fig. 51]

B. How to adjust the link stopper

- Ⓐ With the needle bar in its lowest position, check if there is enough clearance between the trimming cam roller and both ends of the trimming cam when the trimming drive link is pushed in the direction of the arrow(⇐) within the trimming cam moving part.

[Caution]

If there is not enough clearance between the trimming cam roller and both ends of the trimming cam, trimming may not be operated correctly or the machine may be lock when beginning to sew or trimming.

- Ⓑ Make the end of the link stopper screw touch part Ⓐ of the trimming link stick when the trimming cam roller is inserted into the trimming cam moving part. Then, tighten the nut.

[Caution]

If the position is not set appropriately, the return to the previous point after trimming may be delayed and the first stitch may not be tight enough.

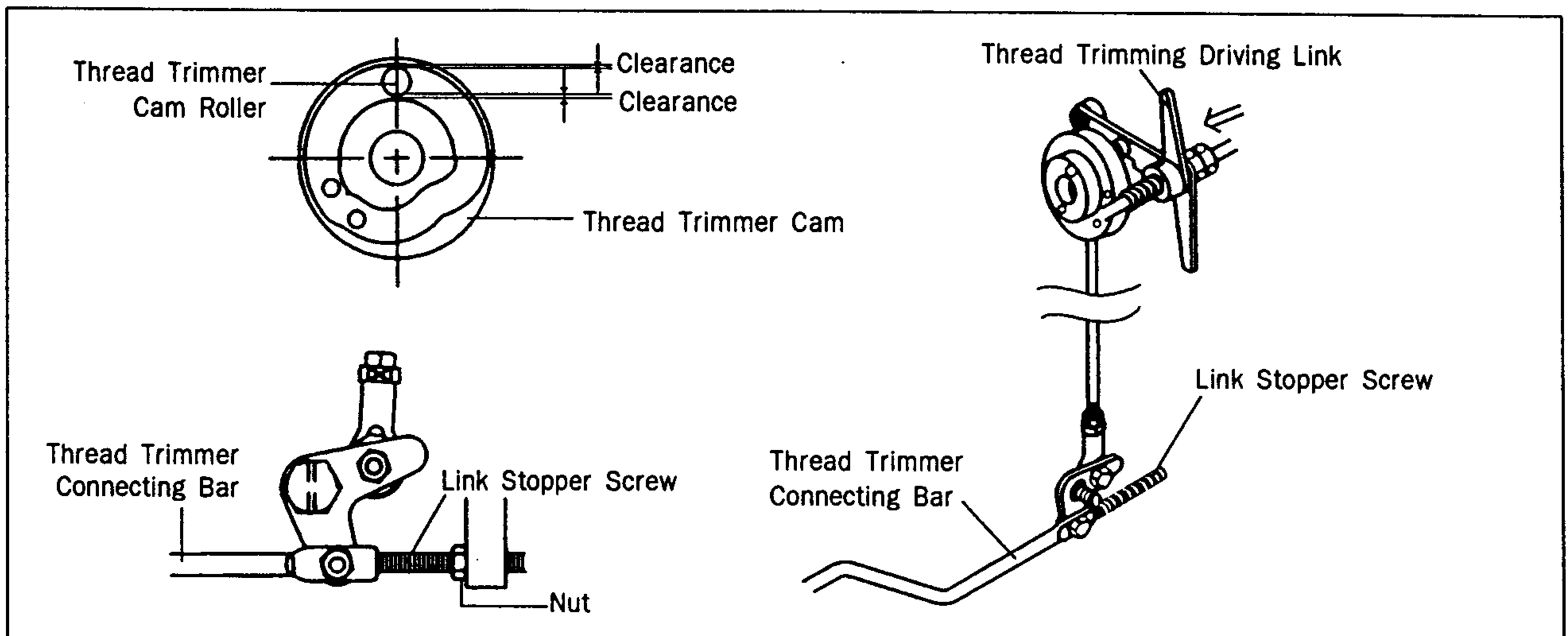

[Fig. 52]

C. Setting the trimming shaft in place

- Ⓐ Unfasten the trimming drive link screw and the trimming shaft collar screw.
 Ⓑ Make the trimming shaft tip accord with part Ⓐ of the arm.
 Ⓒ Tighten the screws.

[Caution]

If the position is not adjusted appropriately, trimming may not be operated correctly or the machine may be lock.

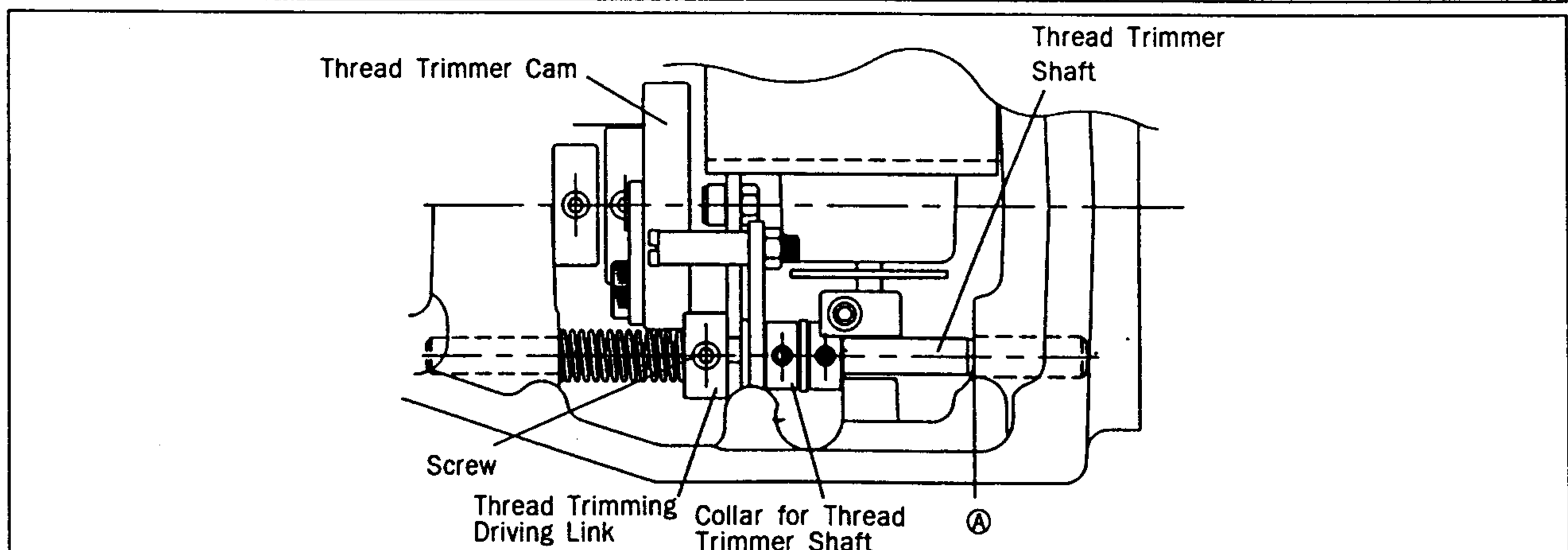

[Fig. 53]

D. Setting the Link Stopper in Place

- Ⓐ Unfasten the trimming drive link stopper screw while trimming is not operated and have the trimming drive link and the trimming drive link stopper notch 0.3mm apart from each other.
- Ⓑ Tighten the screw.

[Caution]
If the link stopper is not set in the right position,trimming may not be operated correctly and the machine may be lock.

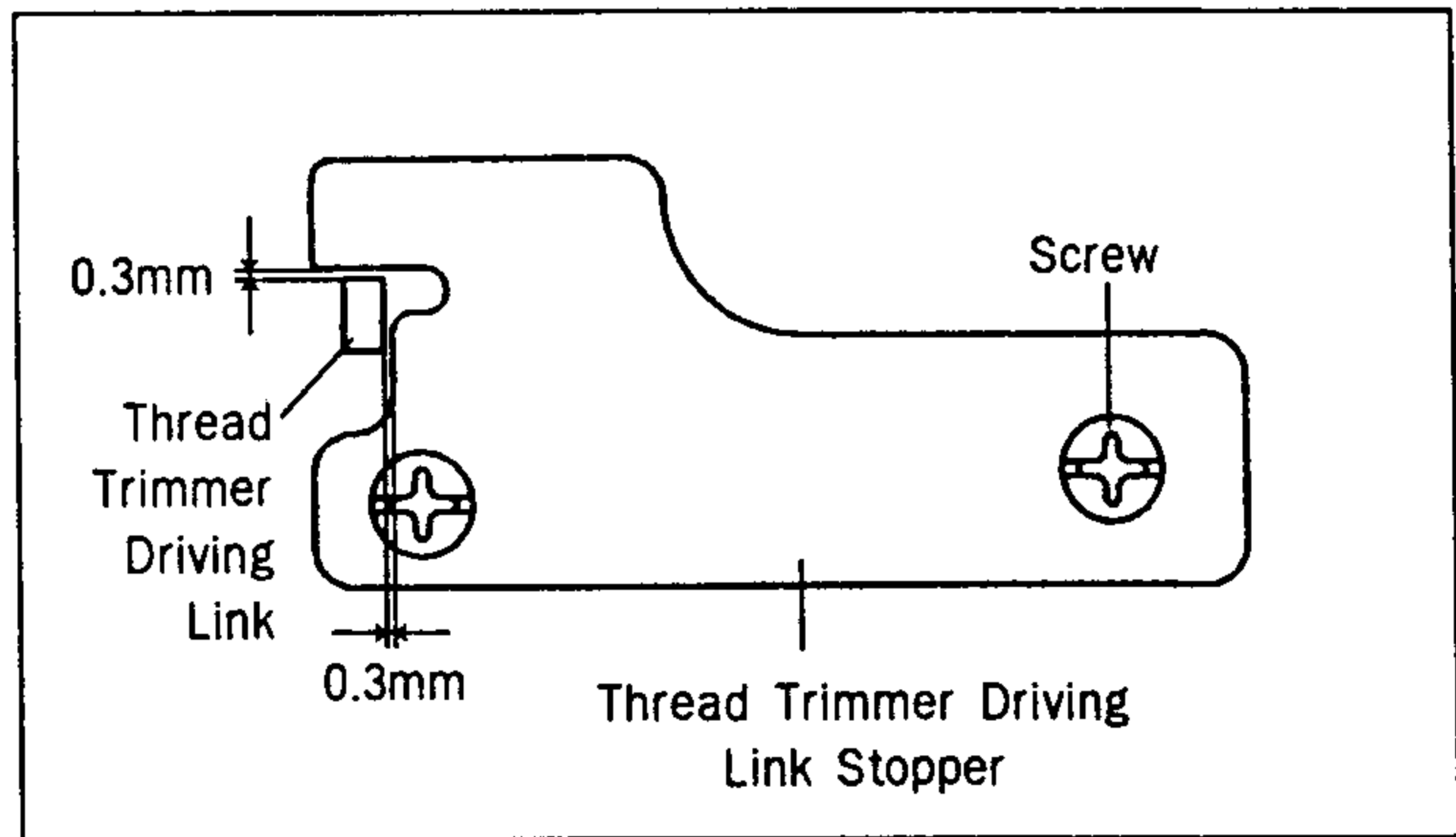

[Fig. 54]

E. Setting the Thread Trimming Solenoid in Place

- Ⓐ After unfastening the thread trimming solenoid bracket screw, have the trimming shaft and th thread trimming solenoid rotary link 0.5mm apart from each other and tighten the screw back on.
- Ⓑ Unfasten the thread trimming solenoid rotary link screw and drive the thread trimming solenoid rotary link manually to move the trimming shaft collar 6.8mm in the direction of the arrow. Then, tighten the screw back on.
- Ⓒ Check if the trimming shaft collar returns to its place when the thread trimming solenoid rotary link returns.

[Caution] If the position is not set right, the trimming return or the thread delay may be delayed to bring poor sewing quality.

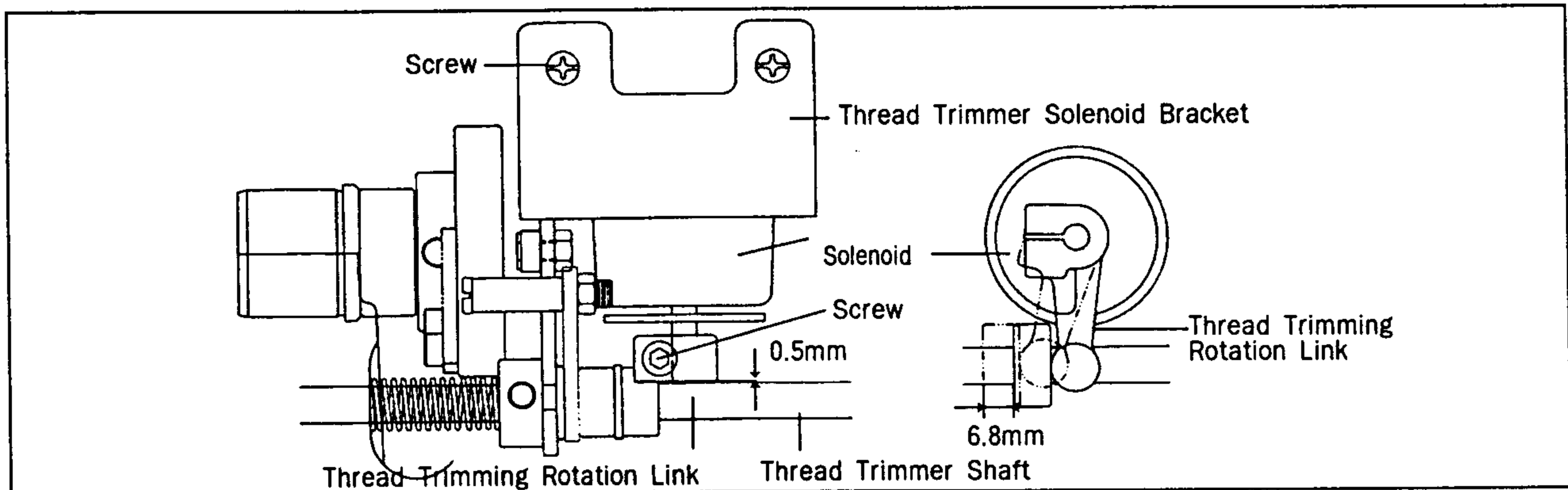

[Fig. 55]

F. Adjusting the Moving Mes and the Fixed Mes

- Ⓐ When the needle bar stops at the upper position, use the trimming lever adjustment screw to adjust space A between the thread separation point of the moving mes and the throat plate hole as indicated in the table.
- Ⓑ Use the fixed mes screw to adjust space B between the fixed plate and the throat plate cover as indicated in the table.
- Ⓒ after the adjustment, check the position of the mes by manual trimming operation.

[Caution]
Trimming may not be operated or there may not be enough remaining thread if the mes is not set appropriately.

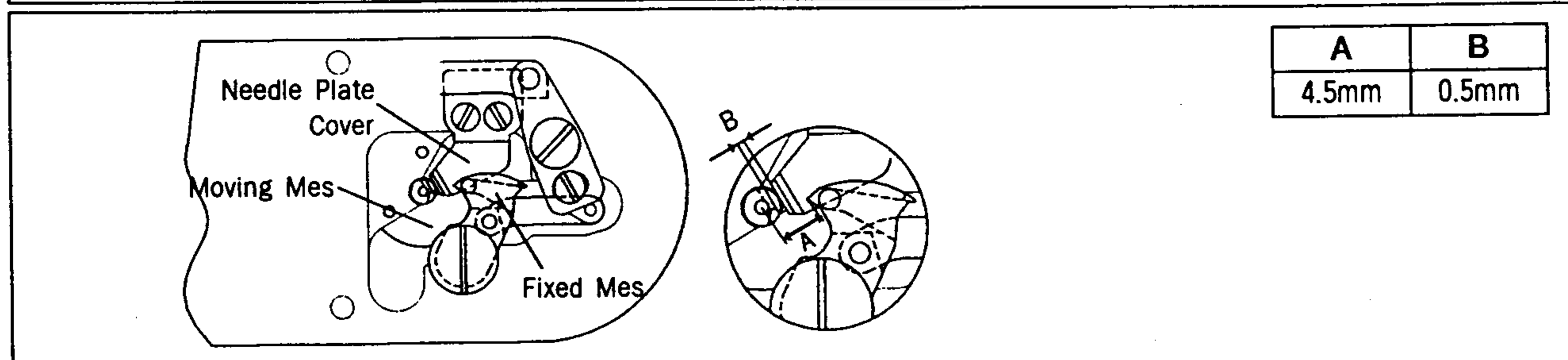

[Fig. 56]

9) Adjusting the devices for main thread Adjustment

- A. When the tension control nut ① of the thread control device is turned clockwise, the upper thread is tightened and becomes loose as the nut is turned counterclockwise. Adjust the tension according to the sewing conditions such as material, thread, number of stitches etc.
- B. To tighten the take-up lever spring, use a driver to turn the groove ② on the edge face of the thread tension control device shaft clockwise. And to make the spring relax, turn it counterclockwise. (Standard operating quantity is 6 ~ 8mm, and tension is about 30g~50g.)

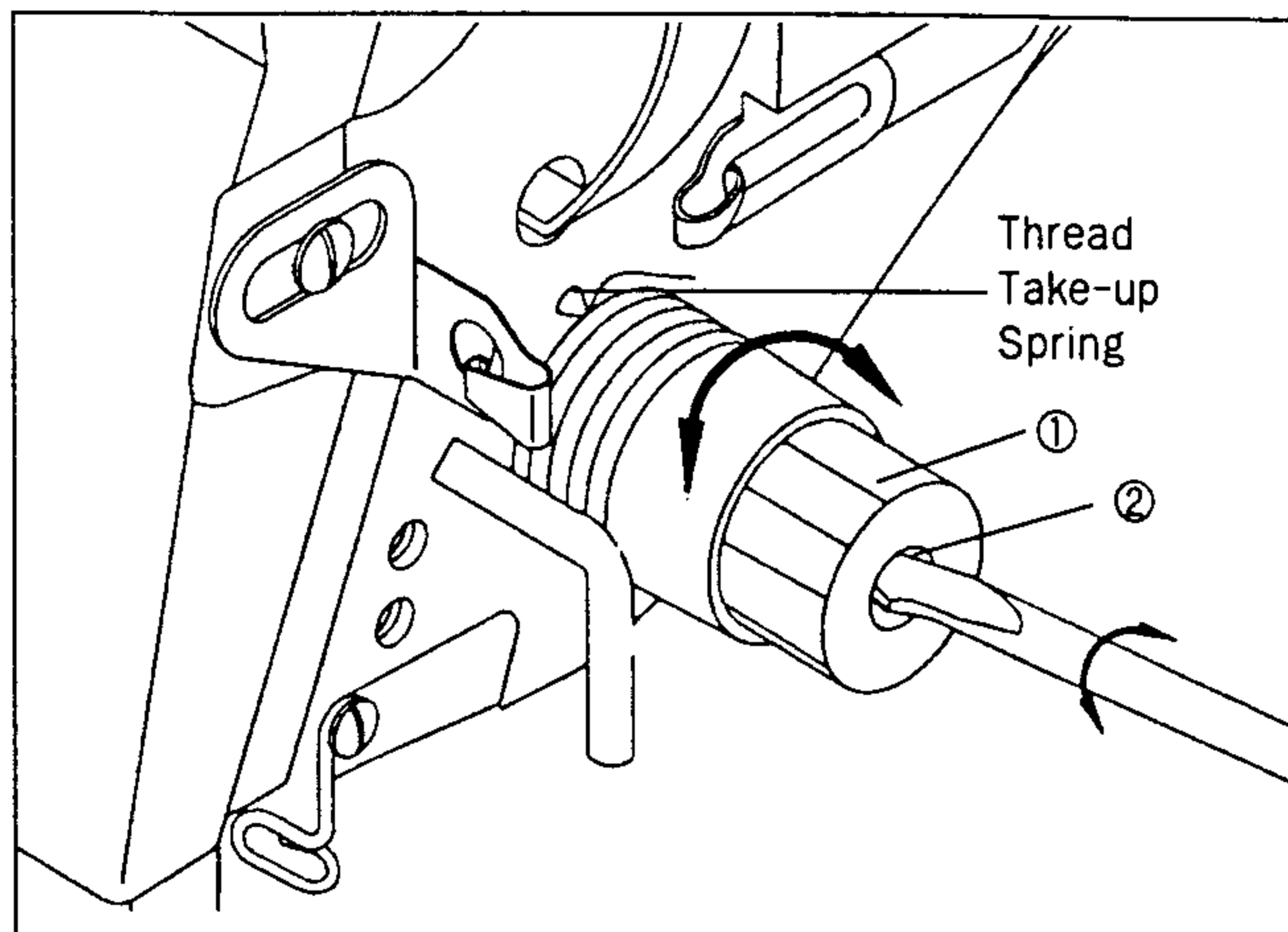

[Fig. 57]

10) Adjusting the winder devices

- A. To adjust the winding capacity of the bobbin, use the beginning position of the winding control plate, and after unfastening the screw, turn the plate in direction A for large winding capacity and turn in direction B for small winding capacity.

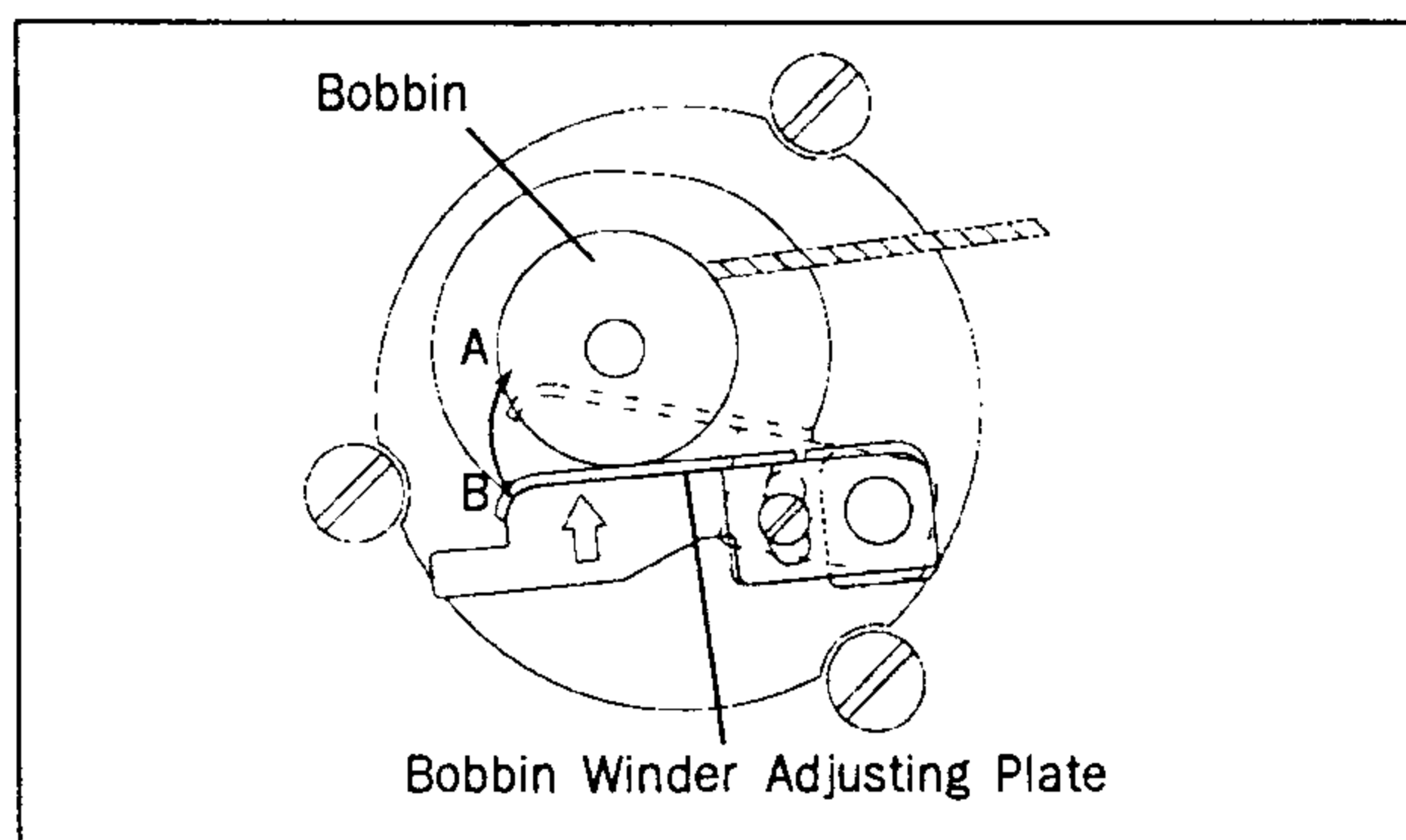

[Fig. 58]

- B. Please fasten the joint screw after adjusting location of thread winder driving wheel to be 4mm from upper shaft bushing.

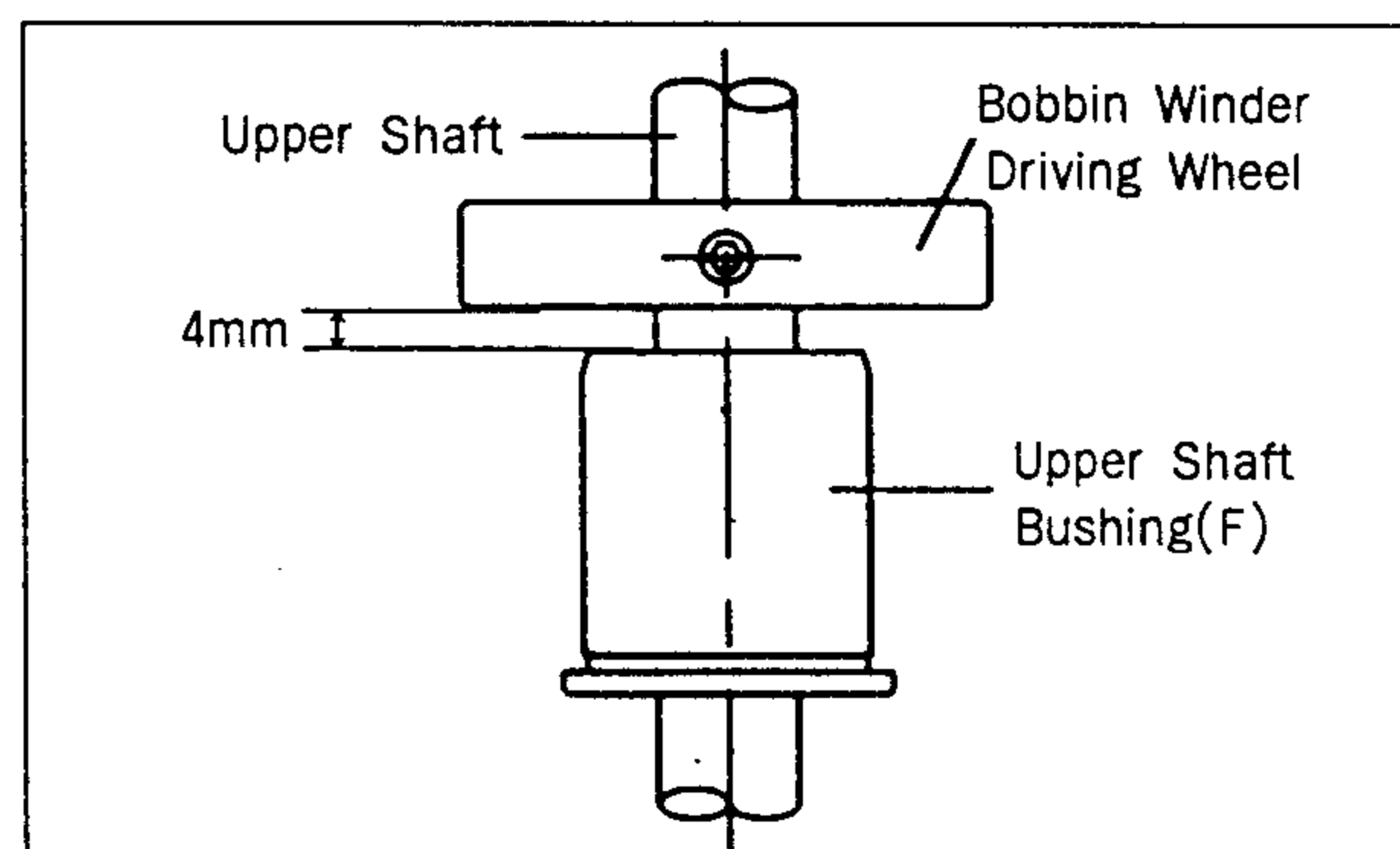

[Fig. 59]

11) Setting up the synchro position

- A. Installing the synchronizer
- ① Fix the synchronizer on the back side of arm.
 - ② Adjust the gap between pulley and synchronizer to be 2.5mm, then fasten the fixing screw for pulley.

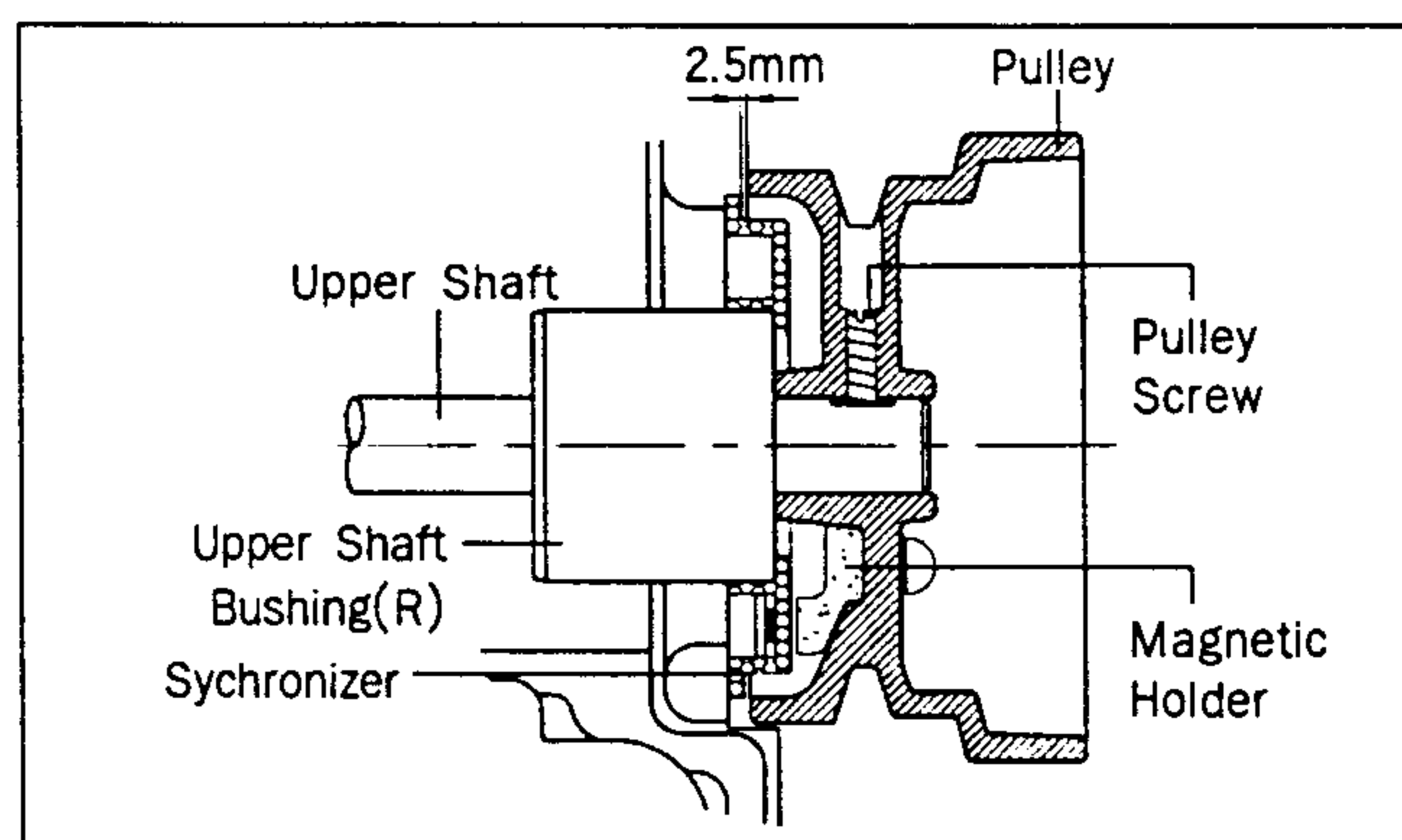

[Fig. 60]

B. Adjusting the position of position detector

- Ⓐ Adjust the position of take-up lever to be same as Fig. 12 by turning the pulley. At this time, the white carving sign ④ of pulley should be straight line with the carving sign ③ of arm.
- Ⓑ Unfasten the screw ① on the N.U carving sign of pulley to be located on the center of space, and fasten the screw again.
- Ⓒ Unfasten the screw ② on the N.D carving sign and move to the right and left, then let it suspend on the place where the needle bar just start ascending from the bottom.

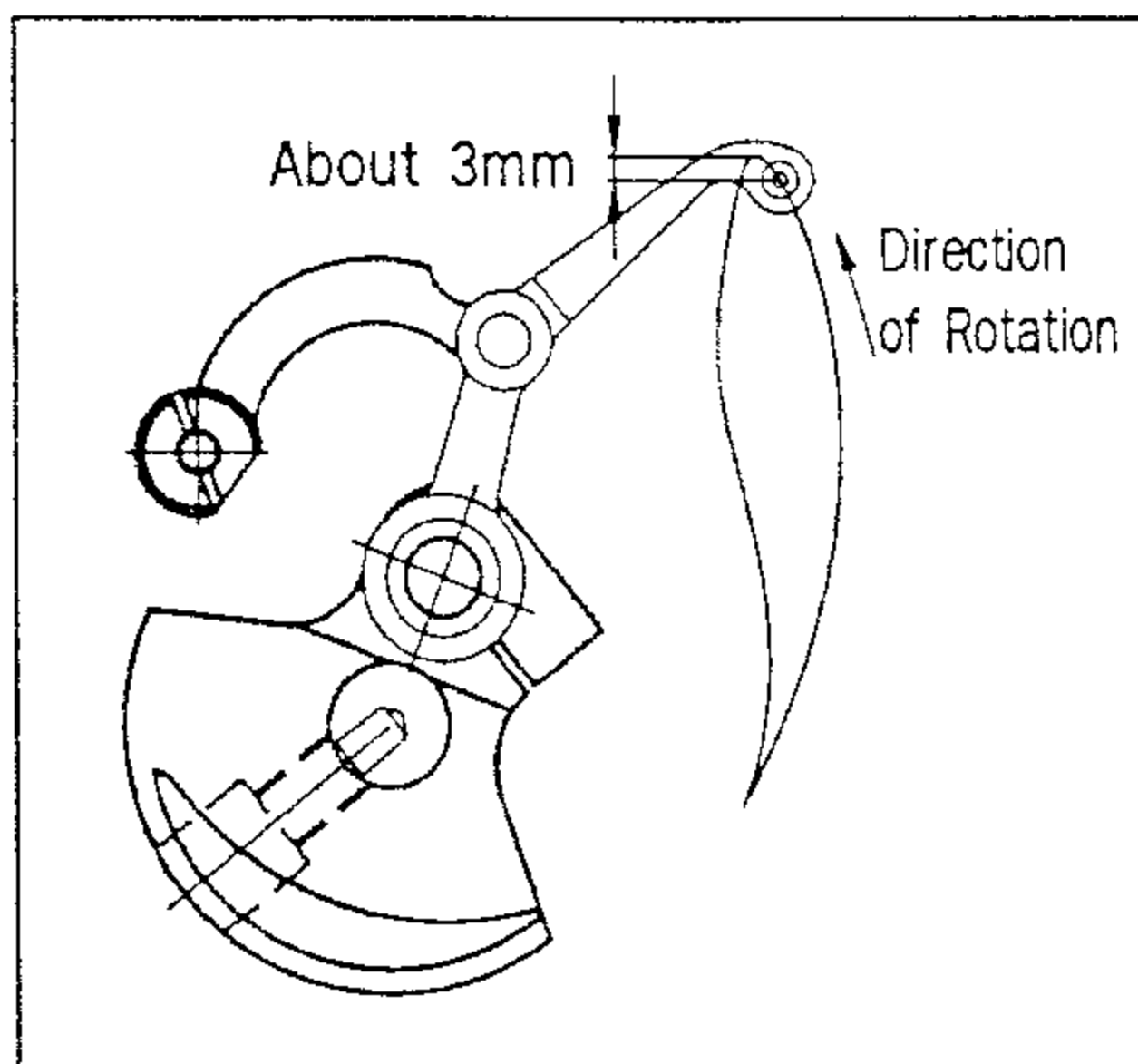

[Fig. 61]

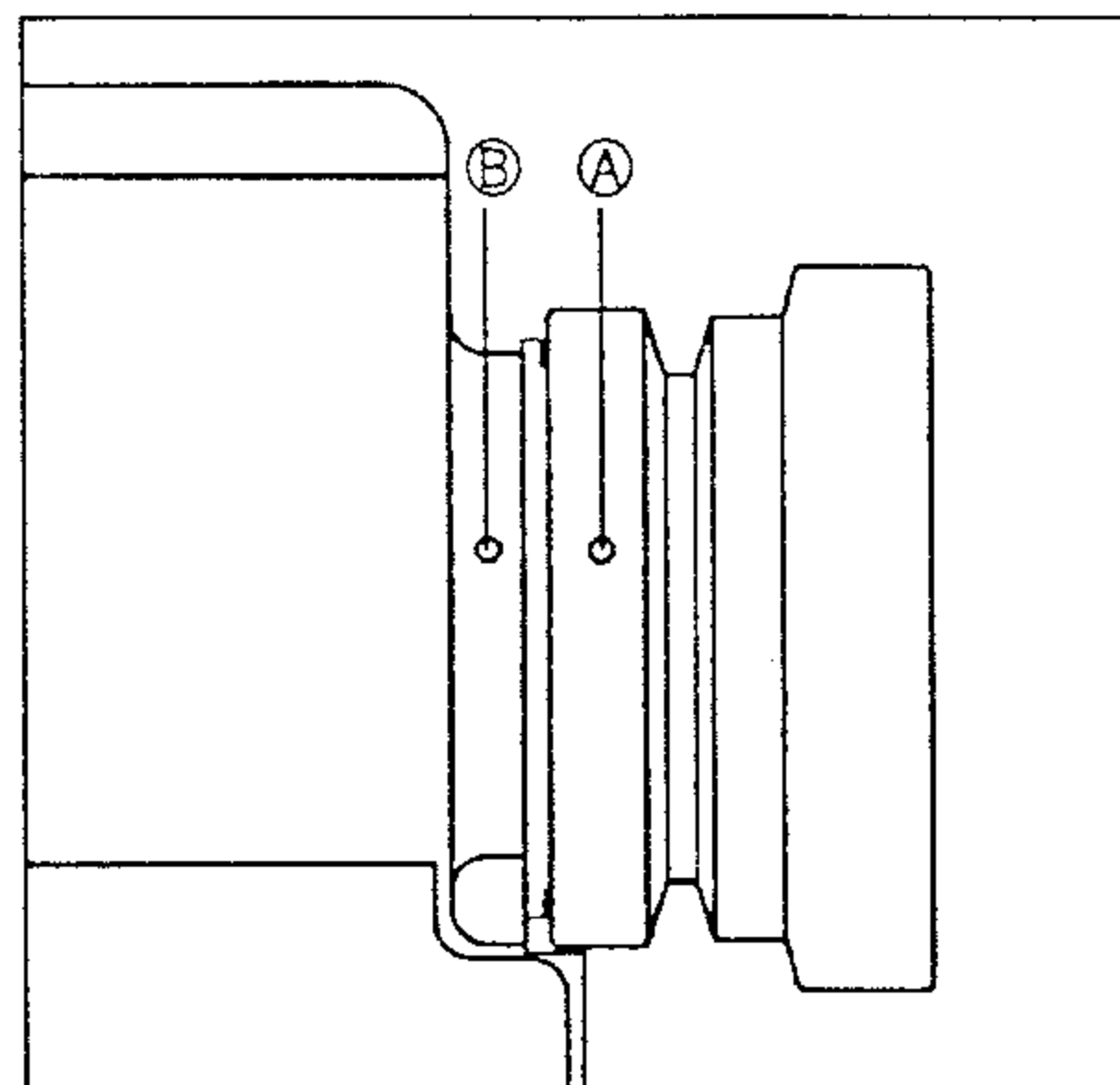

[Fig. 62]

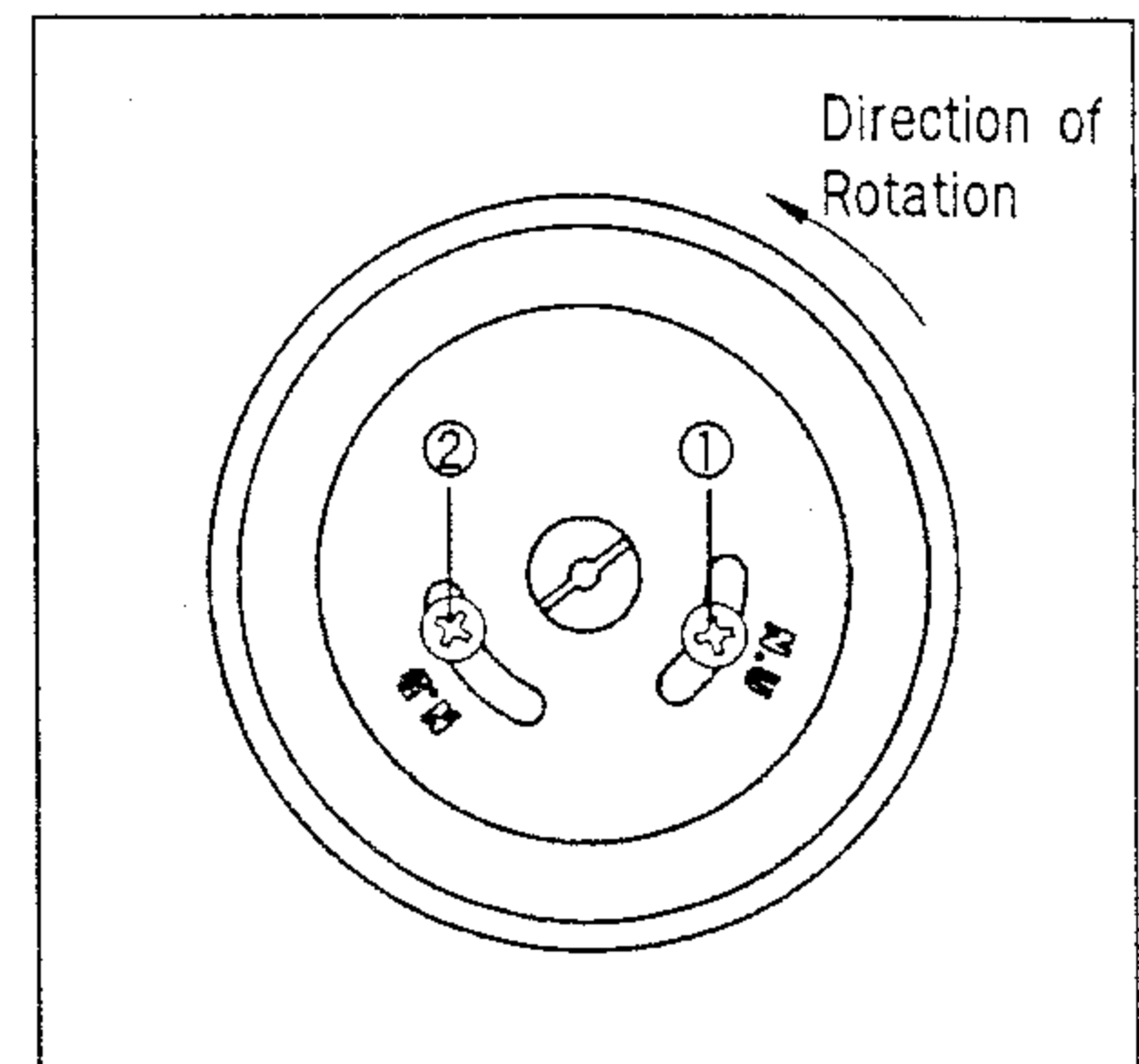

[Fig. 63]

12) Setting up the X-Y Origin

A. How to set up X-axis Origin

- Ⓐ Separate a bed cover (left).
- Ⓑ Move the center of work clamp foot to be placed on the center of X-axis.
- Ⓒ As seen in the figure, unfasten the bolts of X-sensor plate and let the end of X-sensor plate locate on the center of sensor, then fasten the bolts with screw-driver.

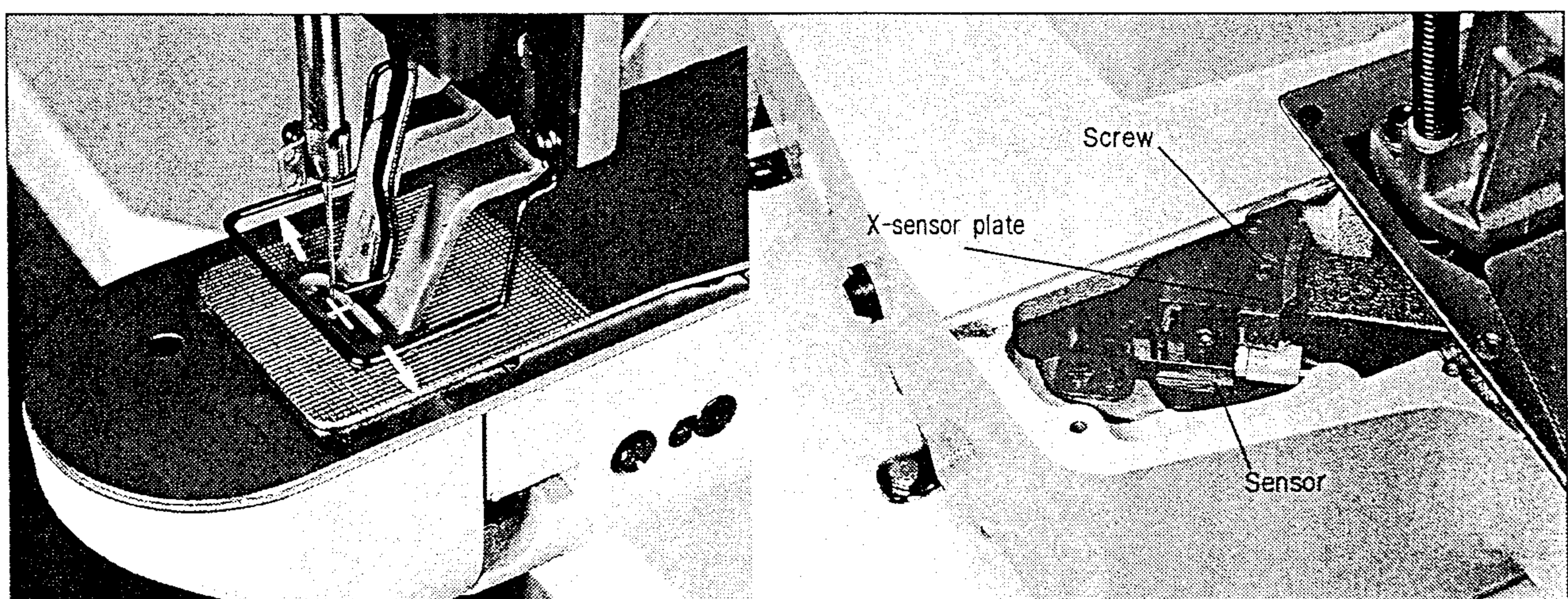

[Fig. 64]

B. How to set up Y-axis Origin

- Ⓐ Separate a bed cover (right).
- Ⓑ Move the center of work clamp foot to be placed on the center of Y-axis.
- Ⓒ As seen in the figure, unfasten the bolts of Y-sensor plate and let the end of X-sensor plate locate on the center of sensor, then fasten the bolts with screw-driver.

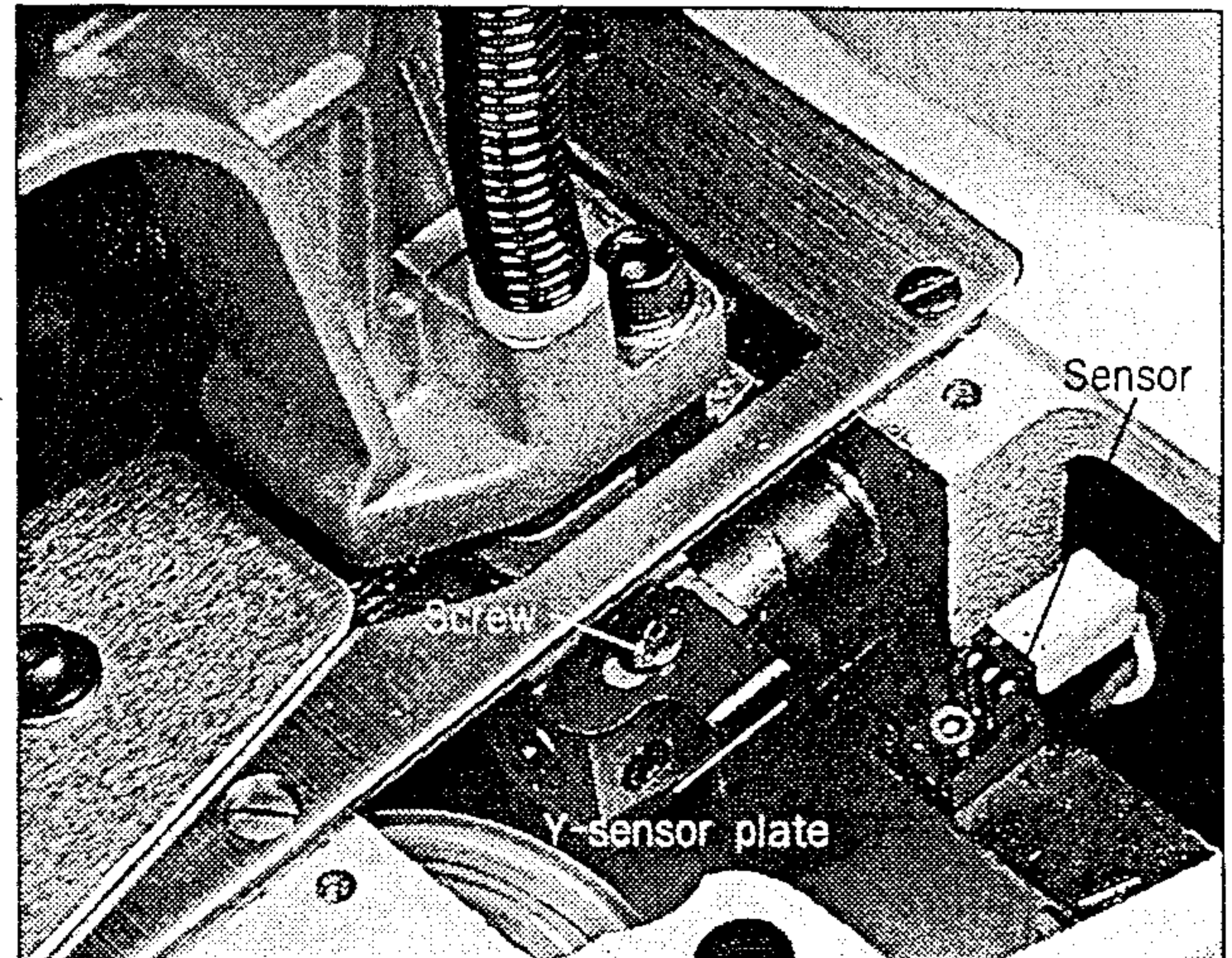
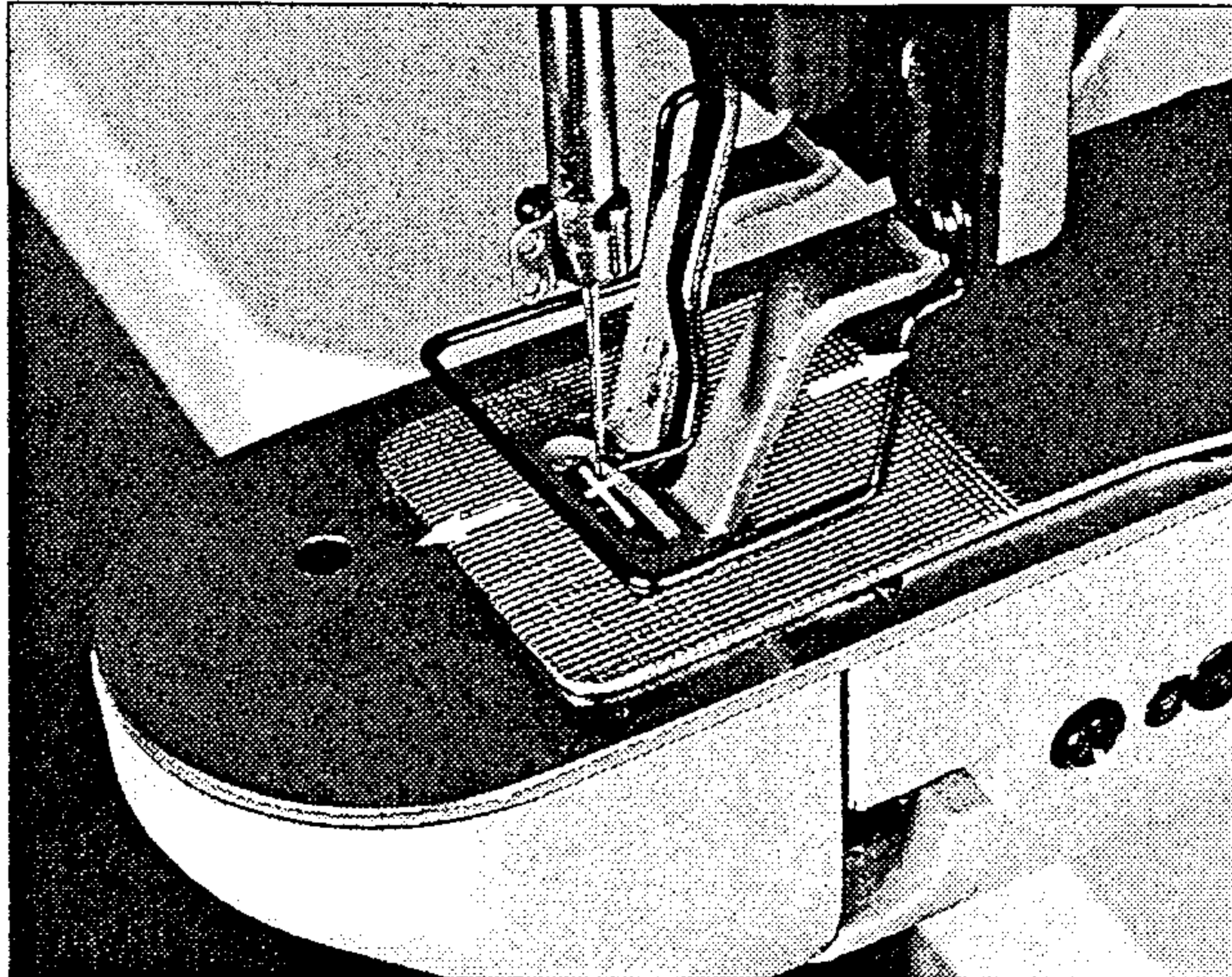

[Fig. 65]

13) Cleaning the Filter



Caution

■ Turn off the power and clean it to prevent from unexpected accident.

Clean up the filter ② of cooling fan once every week.

- 1) Pull out the cover ① of cooling fan to the direction of arrow.
- 2) Wipe out filter ② with flowing water
- 3) Insert the cover ① of cooling fan and filter ② again.

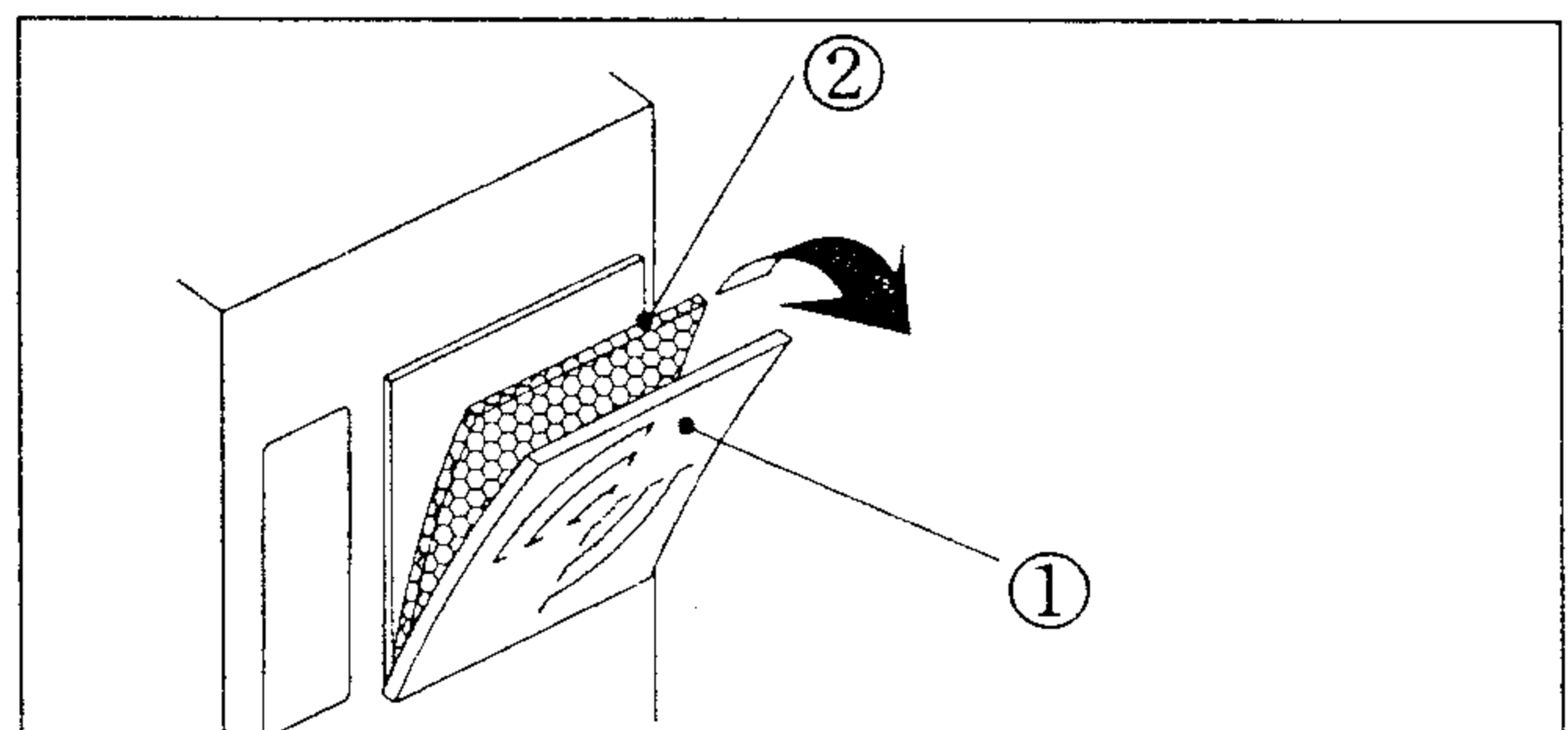

[Fig. 66]

14) Exchanging the Fuse



Caution

■ To prevent from electric shock, turn off the power and wait 5 minutes, then open the cover.

■ Be sure to turn off the power and exchange into the fuse of the designated quantity after opening the cover of control box.

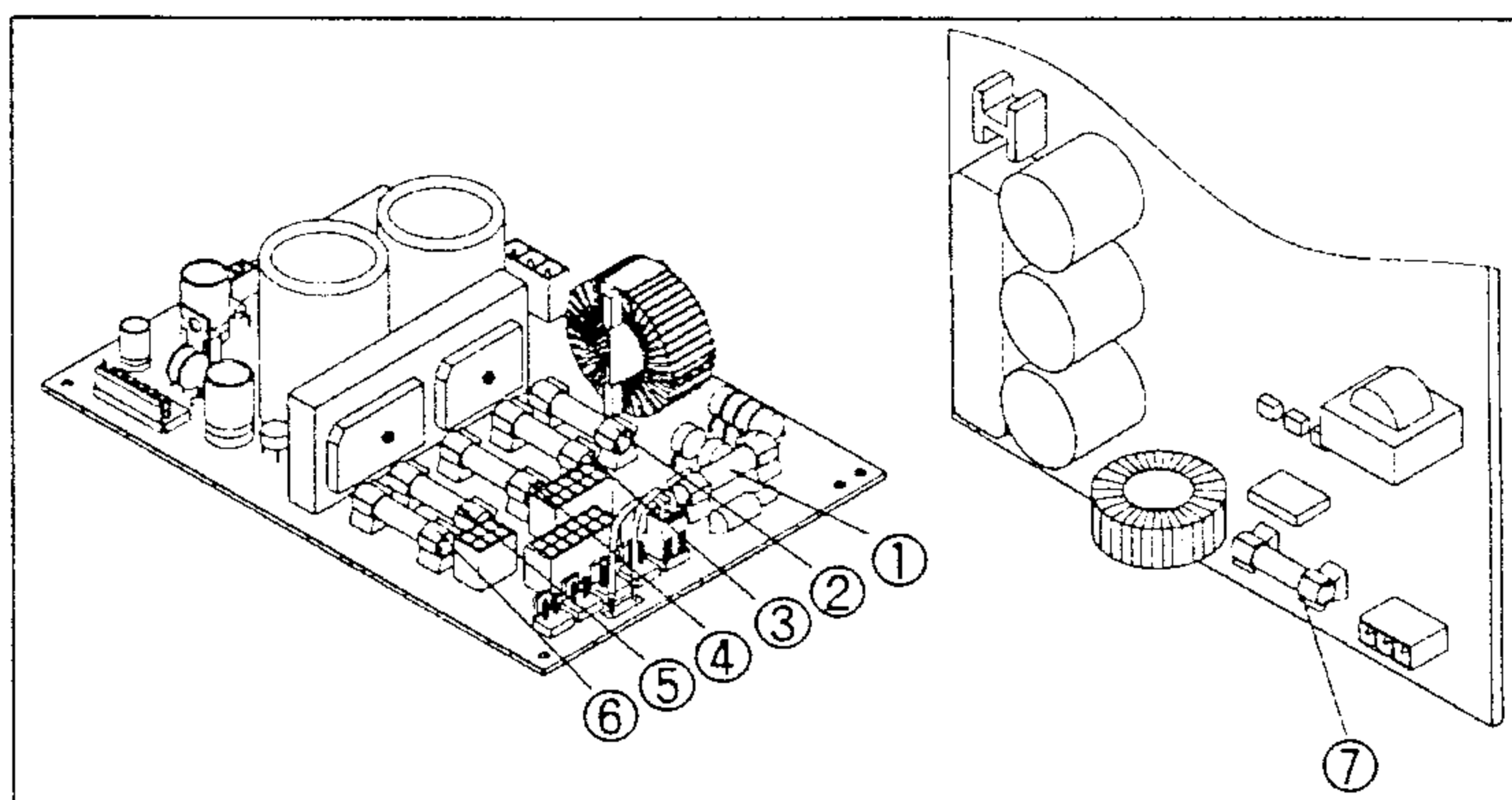

7 fuses are used.

No.	Quantity	Use
①	5A	For the Protection of main power
②	5A	For the Protection of solenoid
③	0.5A	For the protection of air valve
④	0.5A	For the protection of cooling fan
⑤	0.5A	For protection of step motor
⑥	5A	For the protection of step motor drive board control power
⑦	15A	For the protection of servo mote

[Fig. 67]

7

Cause of Breakdown and Troubleshooting

(1) Machine Part

No.	Condition of Breakdown	Cause of Breakdown	Troubleshooting
1	Error on operation or drive of machine	Loosing of belt tension and damage on belt	Adjust the belt tension or exchange it
		Fuse shortage for main power or circuit	Check the fuse shortage of main shaft drive motor in a controller box or exchange it
		Deviation from Y and Y limit of feed bracket	Move the feed bracket to normal place (inside limit switch)
2	Bad position of stopping position	Slackness of main drive belt	Adjust the belt tension
		Due to improper synchro position	Adjust setting position of synchro
3	Needle bent	Damage on needle(Bending of needle, cracks on needle hole or groove, and abrasion or transformation of needle tip)	Exchange the needle
		Wrong installation of needle	Install the needle properly
		Contact of needle with shuttle	Adjust the distance properly between a needle and shuttle
4	Thread is cut	Wrong insertion of thread	Insert the thread properly
		Wrong installation of needle (Height of needle or direction of needle)	Reinstall the needle.
		Damage on needle (Bending of needle, cracks on needle hole or groove, and abrasion or transformation of needle tip)	Exchange the needle.
		Excessive tension of upper thread and under thread	Adjust the tension
		Excessive tension and stroke of take-up lever spring	Adjust the tension and stroke of take-up lever spring
		Crack on the controlling hole of shuttle surface spring	Exchange the shuttle surface spring
5	Stitch skipping	Use of bending needle	Exchange the needle.
		Use of improper sized needle compared with using thread	Exchange the needle.
		Wrong installation of needle	Reinstall the needle.
		Improper timing for needle and shuttle	Readjust the timing for needle and shuttle
		Improper gap between groove and shuttle point	Readjust the timing for needle and shuttle
		Excessive tension of take-up lever spring and stroke	Adjust the tension of take-up lever spring and stroke

No.	Condition of Breakdown	Cause of Breakdown	Troubleshooting
6	Error in thread tightening	Weak tension of upper thread	Readjust the tension of upper thread.
		Weak tension of lower thread	Readjust the tension of lower thread.
		Improper timing for needle and shuttle	Readjust the timing for needle and shuttle
7	Error in trimming	Laxity of exchanging tension between movable mes and fixed mes	Readjust the tension of fixed mes.
		Abrasion and crack on blade of movable mes and fixed mes	Exchange the movable mes and fixed mes.
		Wrong position of trimming cam.	Readjust the position of trimming cam

Pattern List

Application	No.	Pattern	Stitch Number	Range of Sewing	
				X(mm)	Y(mm)
For Heavy and General Materials	1		28	10	2
	2			16	2.5
	3		36	10	2
	4			16	2.5
	5		42	10	2
	6			16	2
	7			16	2.5
	8		56	24	3
	9			24	3
	10			24	3
For Thin Materials	11		21	6	2.5
	12		28	6	2.5
	13		36	6	2.5
Knit	14		14	8	2
	15		21	8	2
	16		28	8	2
Straight Line	17		21	10	0

Application	No.	Pattern	Stitch Number	Range of Sewing	
				X(mm)	Y(mm)
Straight Line	18		28	10	0
	19			25	0
	20		36	25	0
	21		41	25	0
	22		44	35	0
Half Moon	31		42	11	7
	32		42	11	7

Vertical				
No.	23	24	25	26
Pattern				
Stitch Number	28	36	42	56
Range of Sewing	X (mm)	4	4	4
	Y (mm)	20	20	20

Linear Vertical				
No.	27	28	29	30
Pattern				
Stitch Number	18	21	21	28
Range of Sewing	X (mm)	0	0	0
	Y (mm)	20	10	20

Note) 1. It is available to provide 67 patterns except 32 patterns.





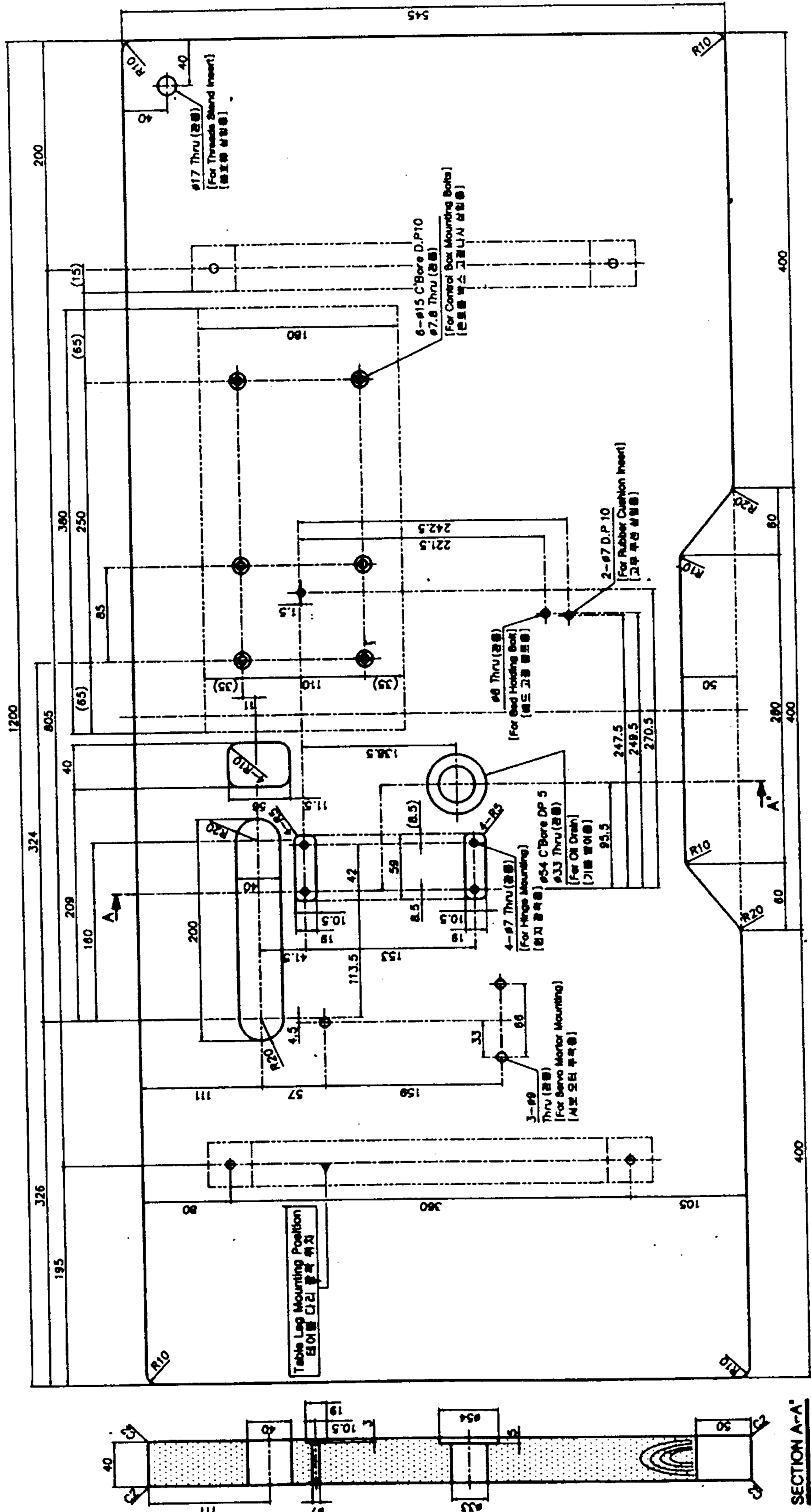





2. Select a presser foot and feeding plate suitable for the sewing method of pattern which you want to use.

Drawing of Table



10

Gauge List

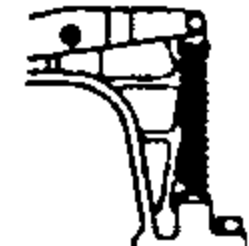
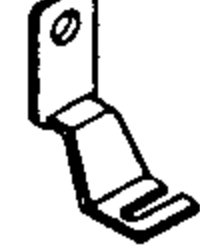
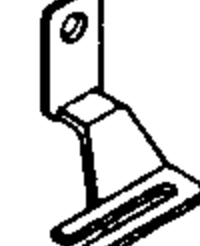
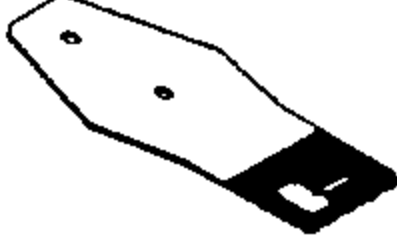
NO.	Name parts	SPS/A-B1201□			
		H(For Heavy weight Materials)	M(For Normal Materials)	L(For Thin Materials)	K(For Knit)
1	Thread Take up Lever Ass'y 	▽ 08S001P-306H		△ 08S001S-306H	
2	Link cam 		02-002A-120H		△ 02S002S-306H
3	Thread Guide of Needle Bar 	04-007A-120H		04-008A-120M	
4	Needle 	DP×17 #19	DP×5 #16 (DP×5 #14)	DP×5 #11	
5	Shuttle Race Ring 	07-021A-120H	07-022A-120H	07-023A-120L	
6	Shuttle 	07-028A-120H		07-029A-120M	
7	Shuttle Upper Spring 		◇ 07S040S-306G	07-041G-120L 07-040G-120L	
8	Thread tension Adjusting Ass'y 	○ 40S001S-306H		◇ 40S001S-306G	
9	Needle Plate Cover 	10-041A-120H	10-042A-120M	10-043A-120K	
10	Trimming Lever-B 			◇ 10S055S-306G	
11	Spring for Lifting Lever 	22-016G-120H		22-016G120M	
12	Work Clamp Foot (Left) 	22-019A-120H	22-021A-120M	22-023A-120L	22-023A-120K
					22-123A-120K
13	Work Clamp Foot (Right) 	22-019A-120H	22-022A-120M	22-024A-120L	22-024A-120K
					22-124A-120K
14	Feeding Plate 	22-029A-120H	22-030A-120M	22-033A-120L	22-035A-120K
				22-034A-120L (without knurling)	22-135A-120K (without knurling)

NOTE) ○ : Common Use with SPS/A-1306H() kinds (Heavy weight materials).
 ◇ : Common Use with SPS/A-1306G() kinds (Normal materials).
 △ : Common Use with SPS/A-1306()S kinds (Standard Stitch).
 ▽ : Common Use with SPS/A-1306()P kinds (Perfect Stitch).

11

Option List

● Standard

Part Name	SPS/A(B)-B1201 <input type="checkbox"/>				
	HA		H		M
WORK CLAMP FOOT					
Ass'y	22-501A-120H		-		-
Left	U:22-601A-120H D:22-602A-120H		22-019A-120H		22-021A-120M
Right	U:22-603A-120H D:22-604A-120H		22-020A-120H		22-022A-120M
FEED FLATE					
	22-143A-120H		22-029A-120H	22-146A-120H	22-030A-120M

Part Name	SPS/A(B)-B1201 <input type="checkbox"/>				
	L(For Thin Materials)		K(For Knit)		
WORK CLAMP FOOT			Without Knurling 	Without Knurling 	
Left	22-023A-120L		22-023A-120K	22-123A-120K	
Right	22-024A-120L		22-024A-120K	22-124A-120K	
FEED FLATE		Without Knurling 	t=0.8 	t=0.8 Without Knurling 	Without Knurling
	22-033A-120L	22-034A-120L	22-035A-120L		22-035A-120K

● Option Type

	Option-1	Option-2	Option-3	Option-4	Option-5	Option-5-1	Option-6
WORK CLAMP FOOT							
(Left)	22-119A-120H	22-121A-120H	22-126A-120H	22-135A-120H	22-141A-120H	22-502A-120H (Ass'y)	22-144A-120H
(Right)	22-120A-120H	22-122A-120H	22-127A-120H	22-136A-120H	22-142A-120H		22-145A-120H
FEED FLATE							
	22-129A-120H	22-130A-120H	22-128A-120H	22-030A-120M	22-143A-120H		22-147A-120H

	Option- Lengthwise	Option-Halt Moon		Option-Circle		
WORK CLAMP FOOT						
(Left)	22-123A-120L	22-131A-120H	22-231A-120H	22-138A-120H	22-238A-120H	22-539A-120H (Ass'y)
(Right)	22-124A-120L	22-132A-120H	22-232A-120H	22-139A-120H	22-239A-120H	
FEED FLATE	Without Knurling 					
	22-133A-120L	22-134A-120H	22-234A-120H	22-140A-120H	22-240A-120H	
FINGER GUARD		—	—			
	22-125A-120H	—	—	22-125A-120H		

12

Pneumatic Diagram

1) SPS/A-B1201HA-20

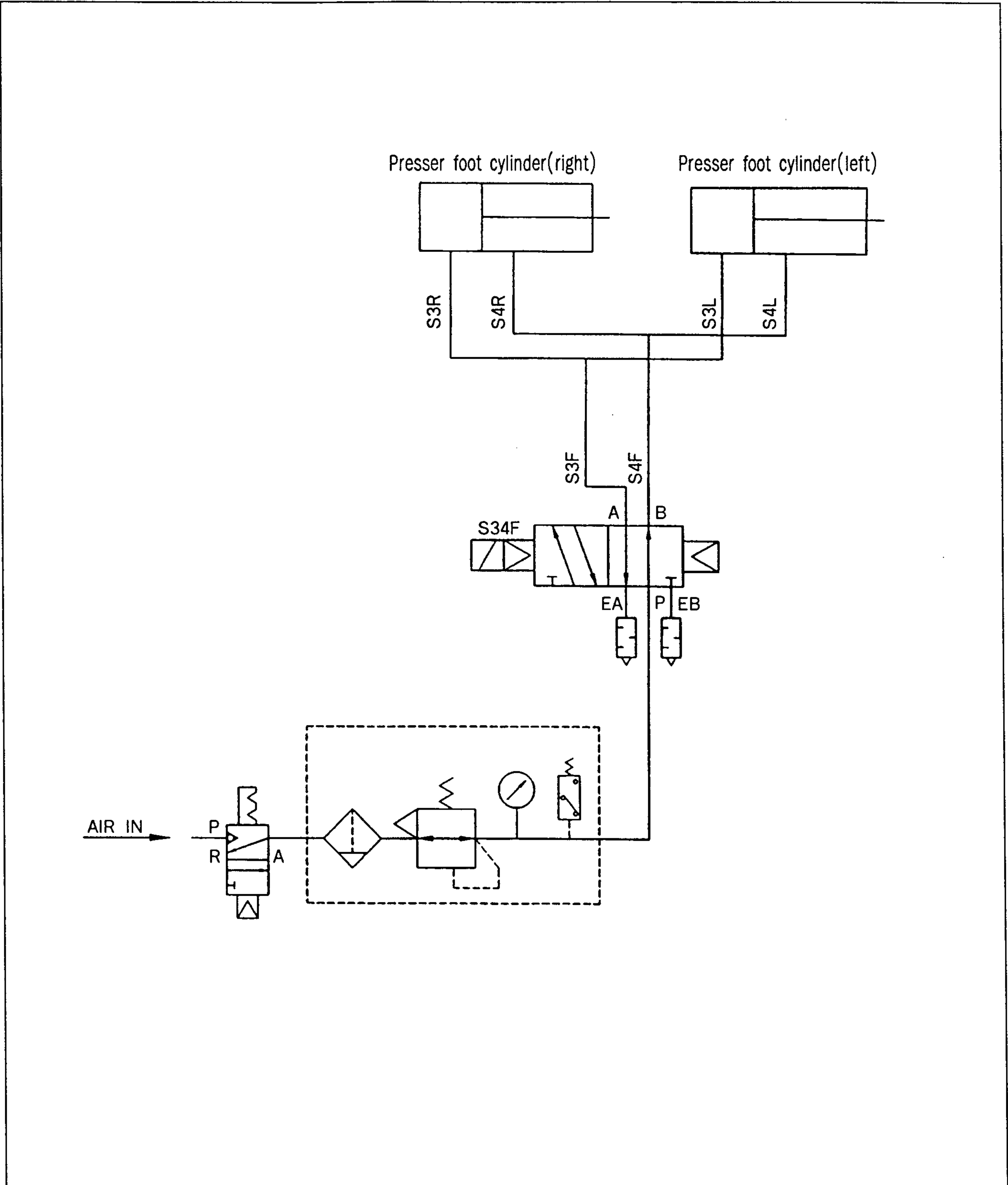

2) SPS/A-B1201HA-22

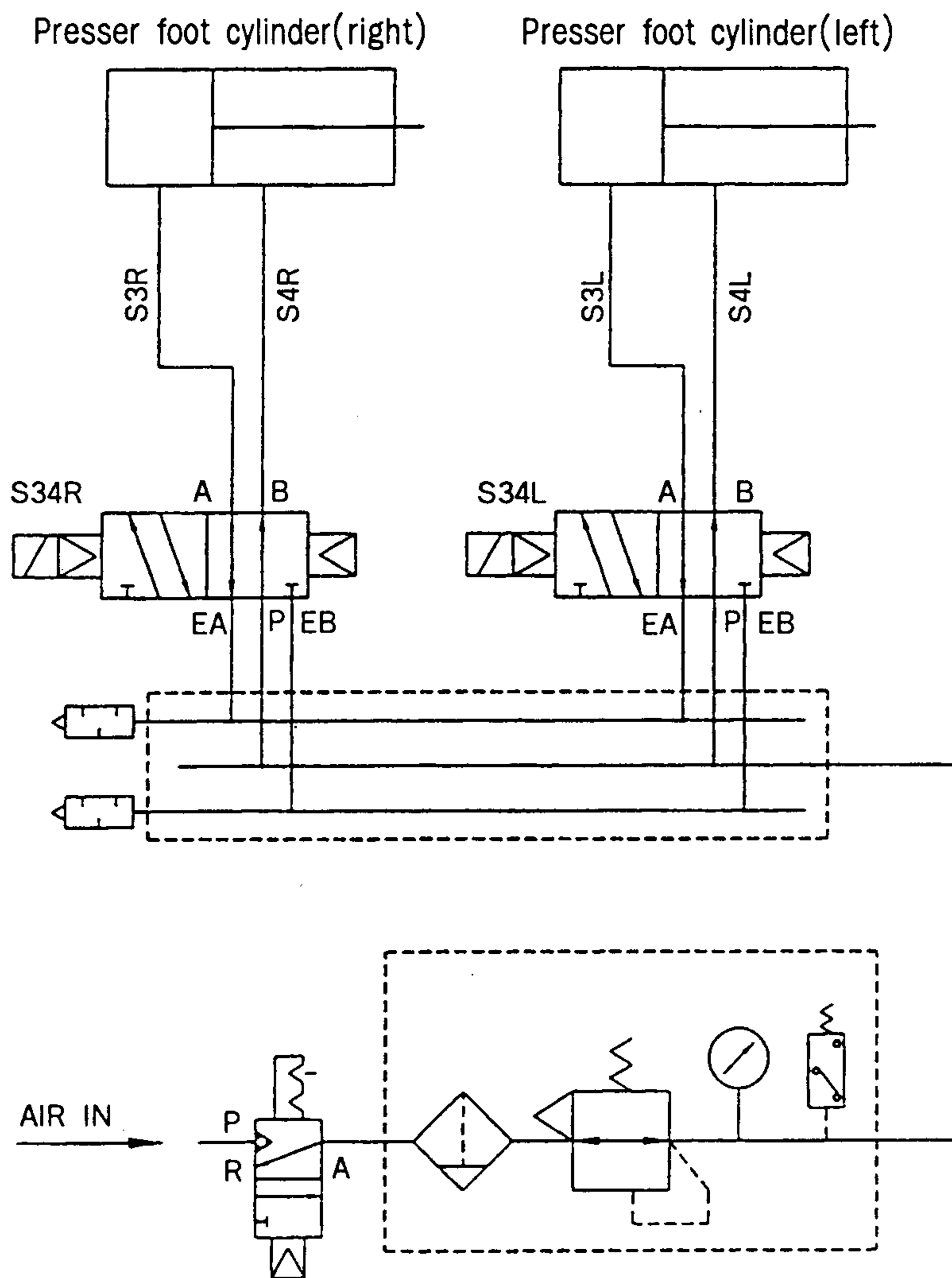

Instruction Manual

Section 2

To program refer to section 2, page 11. In order to sew using the combination of patterns, you must first program the pattern using the P1 thru P7. Each one of the P is a certain type of tack. (refer to section 2 page 11 to program the P. To do this turn the machine off, hold the (select) button and turn the machine on. Now use the (A button for P1), (B button for P2), (C button for P3) and combinations of the A,B C buttons to get P4 thru P7. Now press the select button again and use the forward or backward to select the type of tack to be assigned to the P1. or which ever P has been selected. Use the select button to set up how the tack is to be configured.

To use the combination program. refer to section 2 page 12. To do this turn the machine off and hold the select button and A while you turn on the machine.

Contents

.....

1. Operation of sewing machine (Basic) -----	6
1) Name and Role of Operation Box Keys -----	6
2) Setting the item data -----	7
3) Confirming the Pattern-----	9
4) Sewing -----	9
5) Changing the sewing pattern -----	10
6) Winding the bottom thread -----	10
2. Operation of sewing machine (application) -----	11
1) Using the user's programs-----	11
2) Sewing to use the function of combination -----	12
3) Sewing used with bottom thread counter -----	13
4) Cautions -----	14
3. How to use the memory switch -----	15
1) Running the memory switch -----	15
2) Examples of setting up the memory switch -----	15
3) Function chart of memory switch -----	19
4. The Rest -----	22
1) Testing the Machine -----	22
2) Using Other Function-----	24
3) ROM Mounting and Alternation Method -----	25
5. Breakdown and Troubleshooting-----	30
(Electrical Parts)	
6. Error List -----	31
7. Electronic Circuit Diagram -----	32
8. How Select the Sewing Pattern List -----	35
and the Sewing Lange	
1) B1201 Series -----	35
2) B1202 Series -----	36
9. Basic Manual -----	37



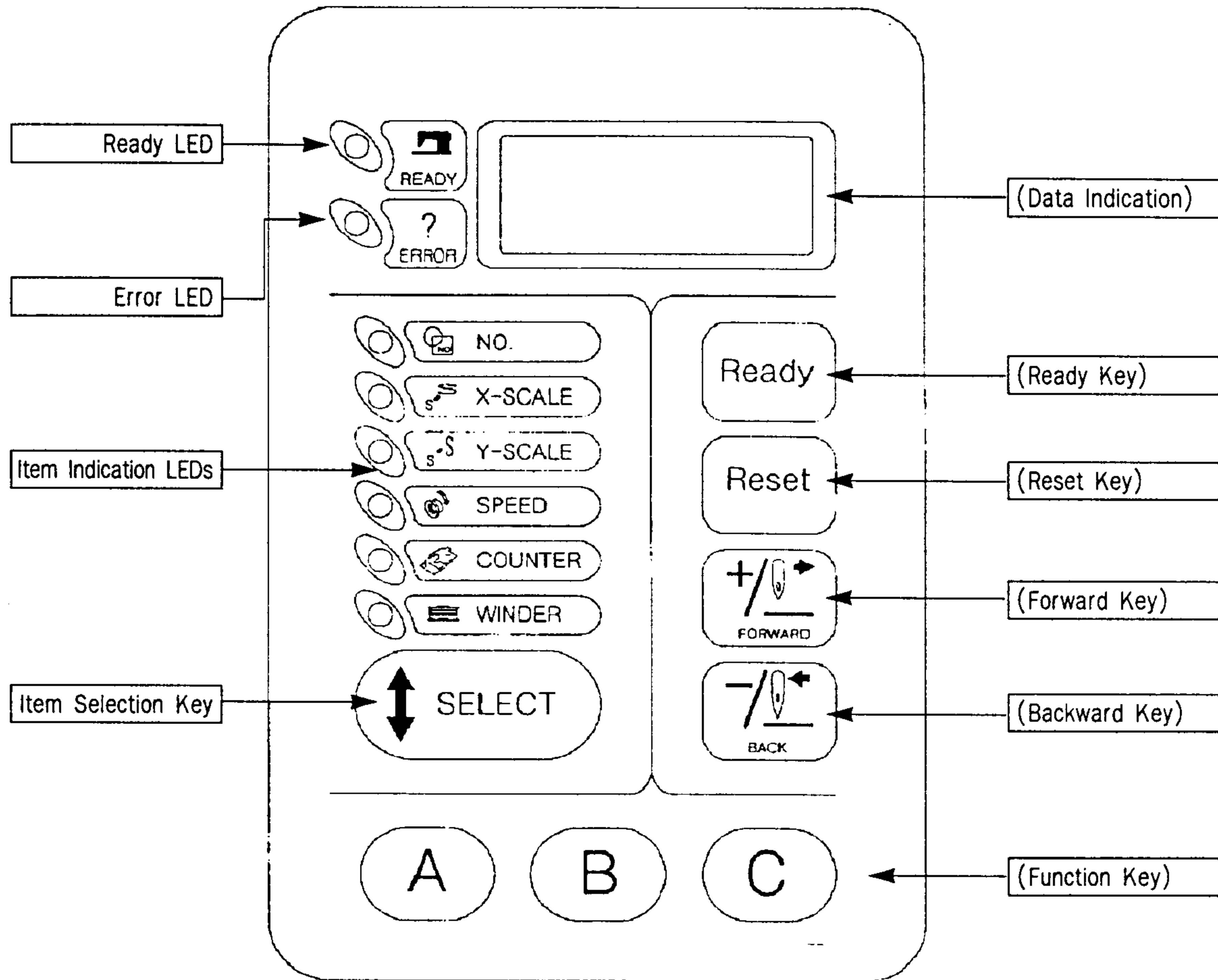

Operation of sewing Machine (Basic)

1) Name and Role of Operation Box keys

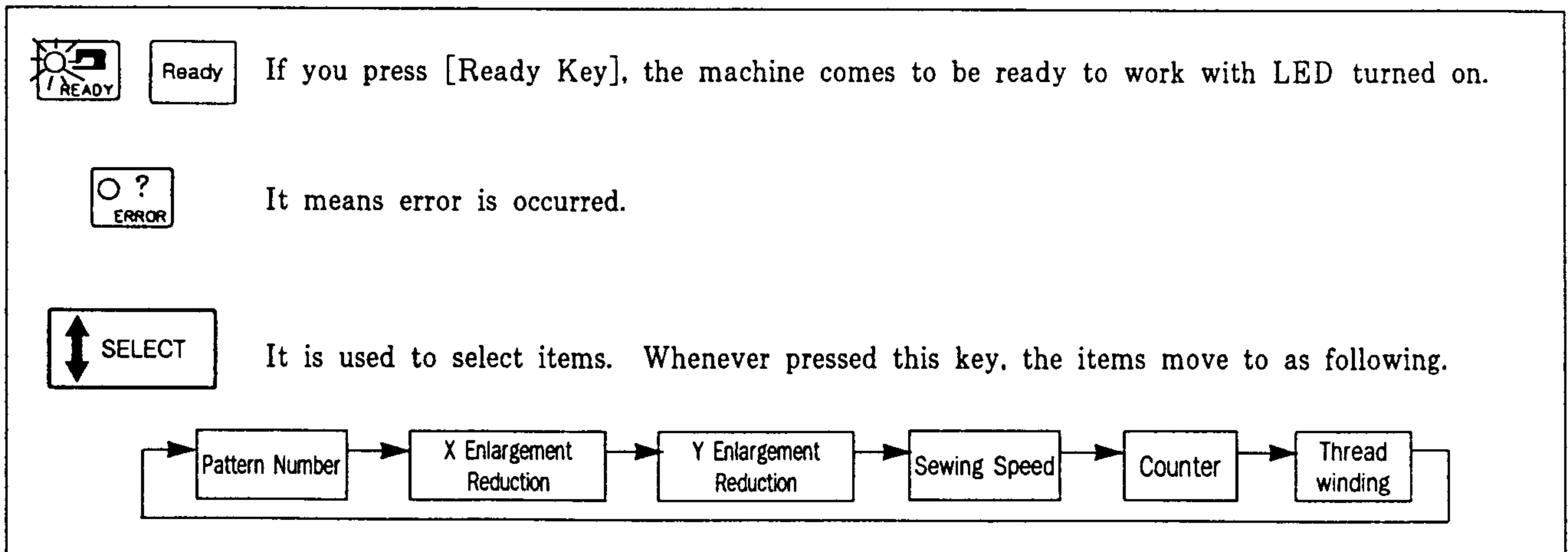

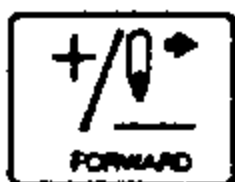
※ First if you turn on power, the pattern number performed previously appears.
The role of LED and keys are as follows.

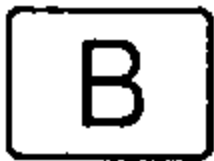

	It is used to back to the initial state.
 	It is used to increase and decrease the value or forward and backward the needle bar.
  	It is used to call a specific pattern with only a key operation.

2) Setting the Item Data

Set up each item as below.

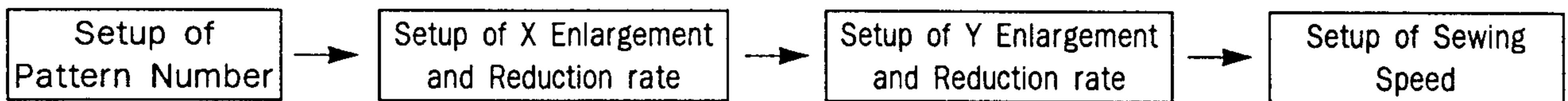

A. Turn on the main switch.

The lamp in the pattern number is turned on, and the pattern number performed previously is indicated.

B. Setup of pattern number

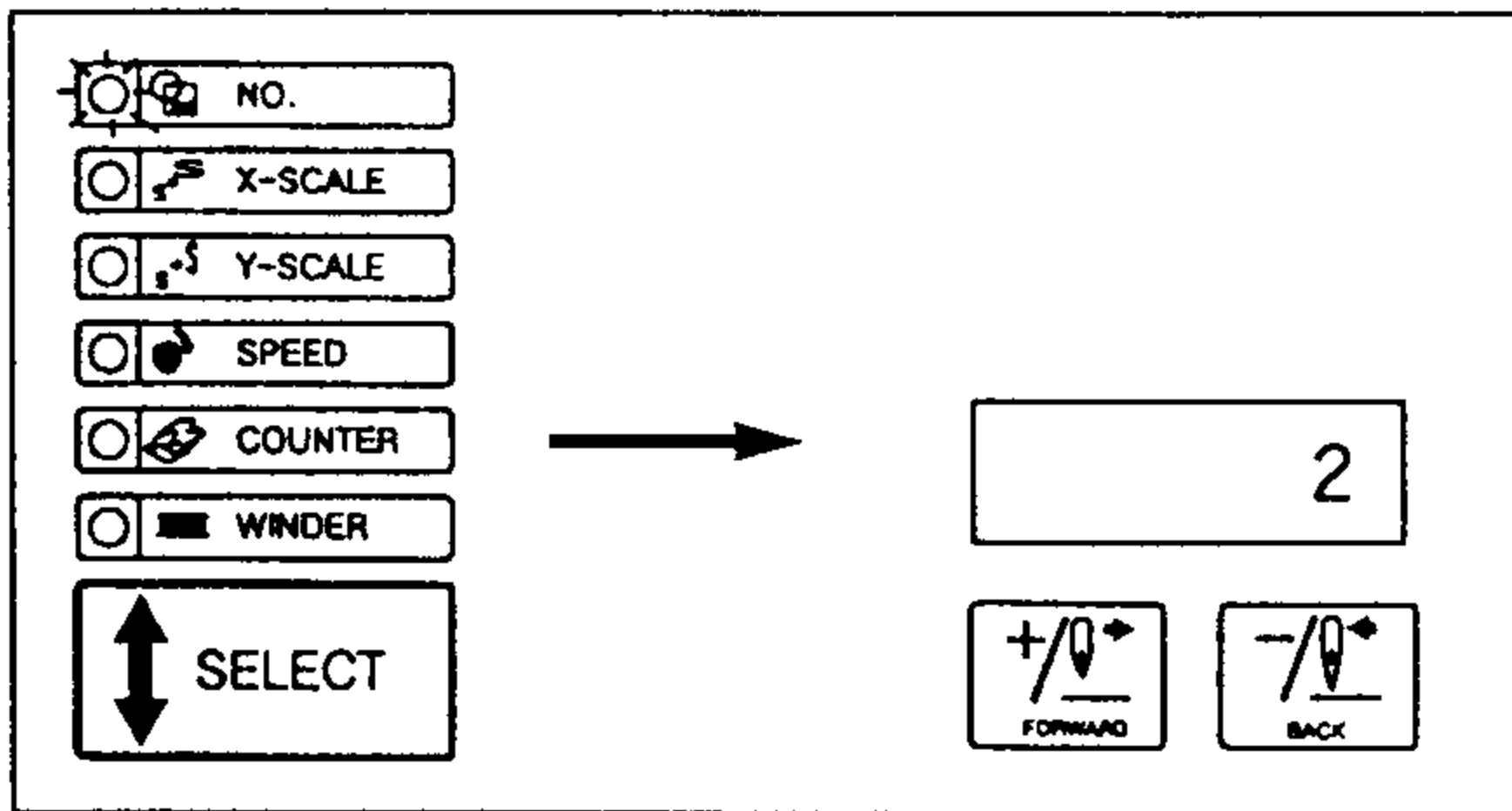

1. Press **SELECT** until NO item is indicated.
2. Press **+ / FORWARD** **- / BACK** until "2" is indicated on the screen.

※ Please refer to annexed program list.

C. Setup of X Enlargement and Reduction

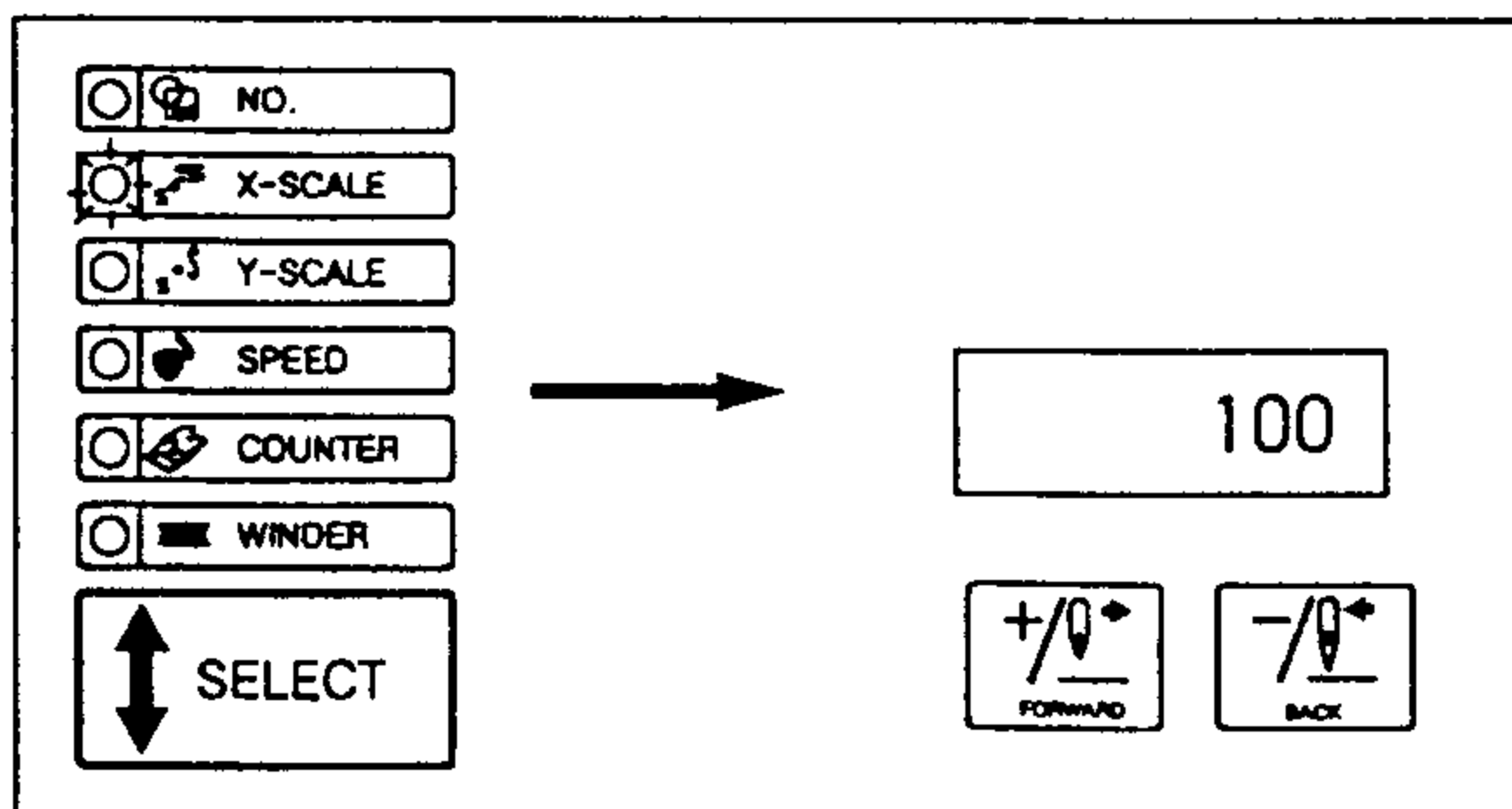

1. Press **SELECT** until X-SCALE item is indicated.
2. Press **+ / FORWARD** **- / BACK** and set the scale within 20% ~ 200%

D. Setup of Y Enlargement and Reduction

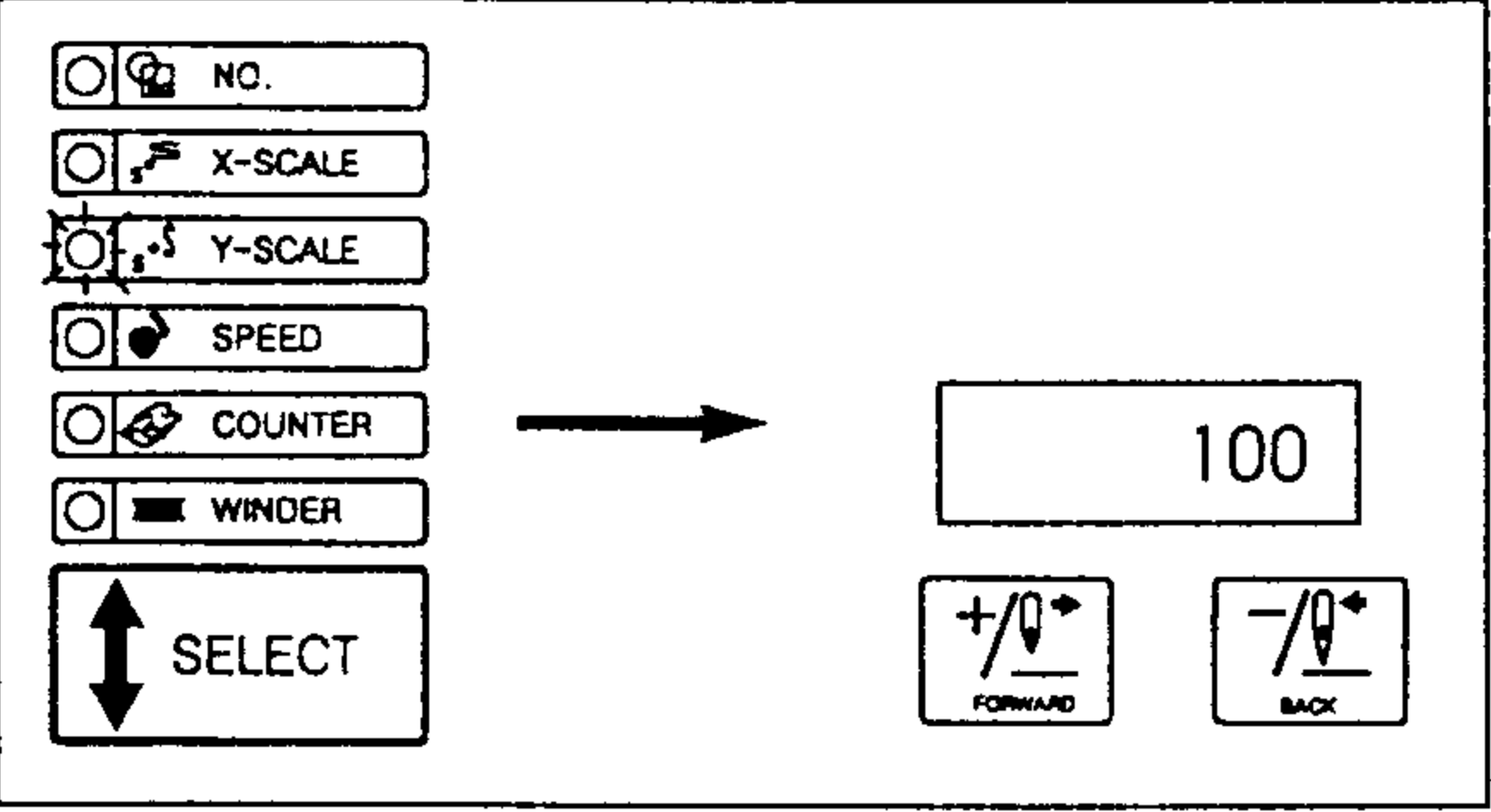

1. Press **SELECT** until Y-SCALE item indicated.
2. Press **+/FORWARD** **-/BACK** and set up the scale within 20% ~ 200%

E. Setup of Sewing Speed

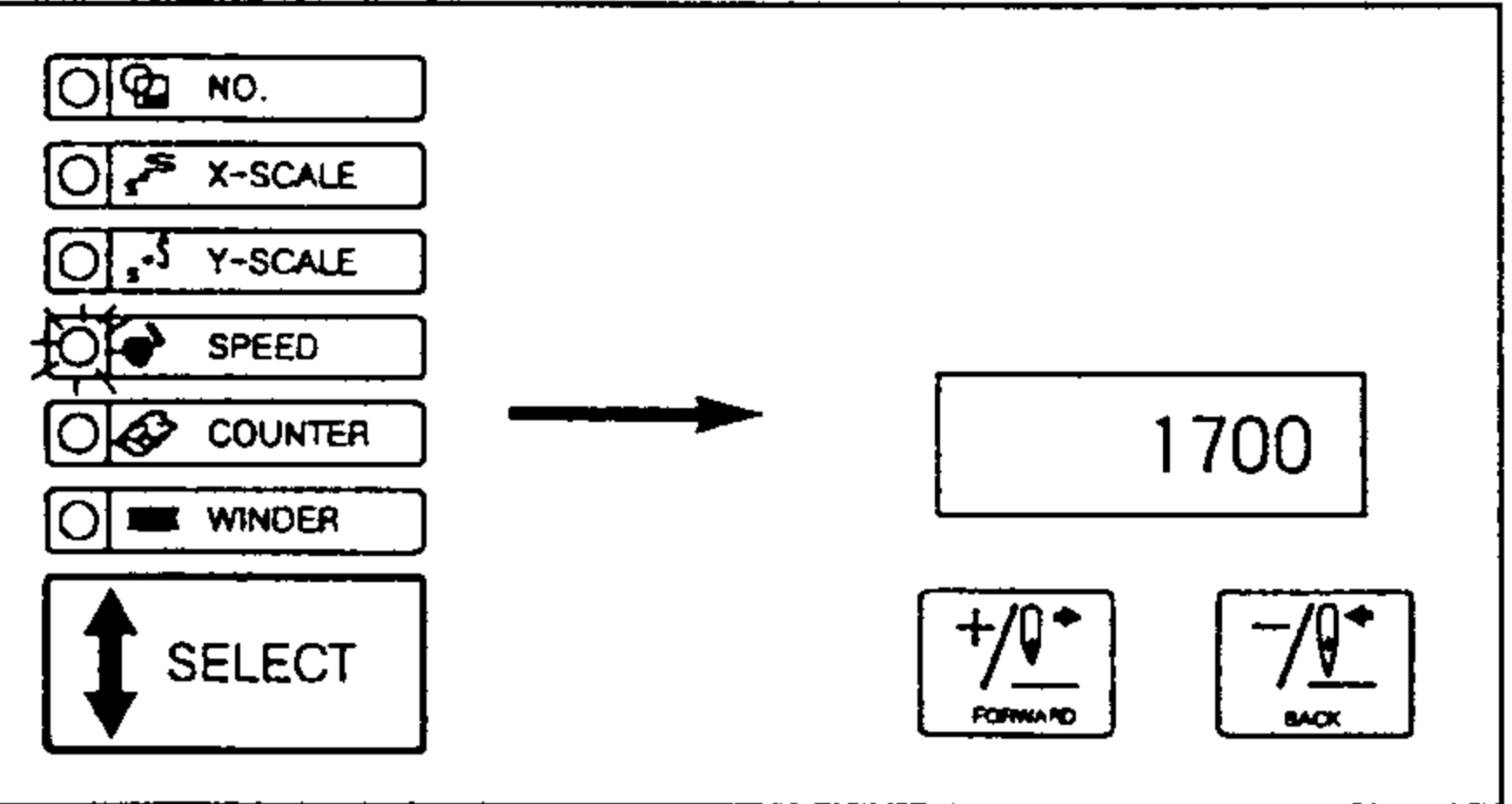

1. By Pressing **SELECT** to make SPEED appear on the screen.
2. By pressing **+/FORWARD** and **-/BACK** to "1700" appear on the screen.

F. Completion of setup

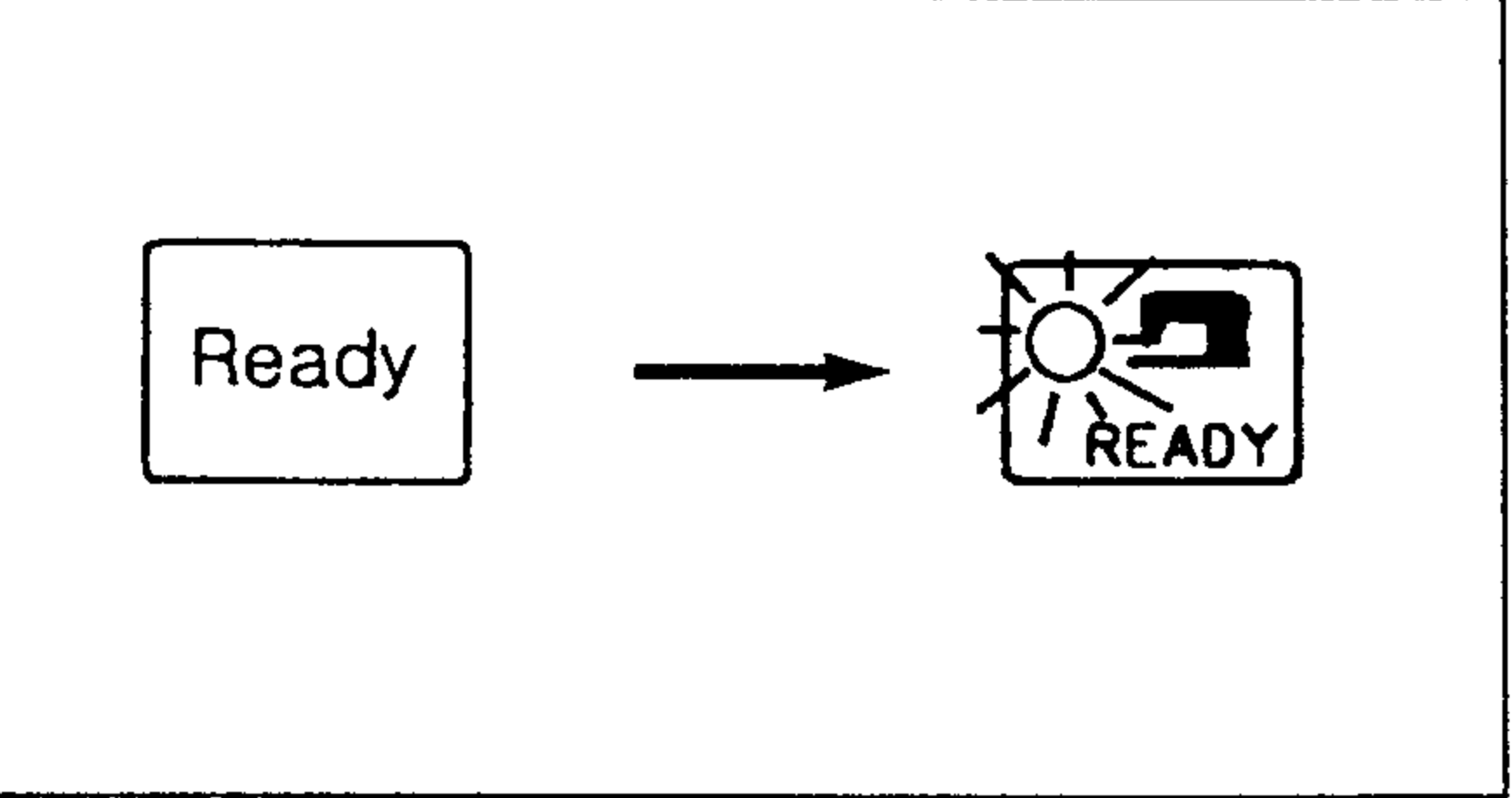

1. Press **Ready**.
2. After the feeding frame moves and ascends, the lamp on Ready turns on and becomes sewing available state.
 - * It is possible to reconfirm the setting value by pressing **SELECT**.

[Caution]

Confirm the pattern number.

If you press **Ready** at the state of pattern No. "0" (factory-installed condition), the machine moves to the origin. Use this pattern to confirm the origin.

If you select pattern number that does not have any data, "E-01" error is marked. At this time, set up another pattern number.

3) Confirming the pattern



Caution

- After selecting a pattern number, confirm the pattern. If the pattern gets out of feeding limit of feeding of feeding frame, serious problems can be occurred including needle breaking since the needle is involved in the feeding frame.
- During checking the pattern, do not press the pedal switch to the 2nd step. When the pedal switch is pressed to the 2nd step, the sewing machine comes to move.

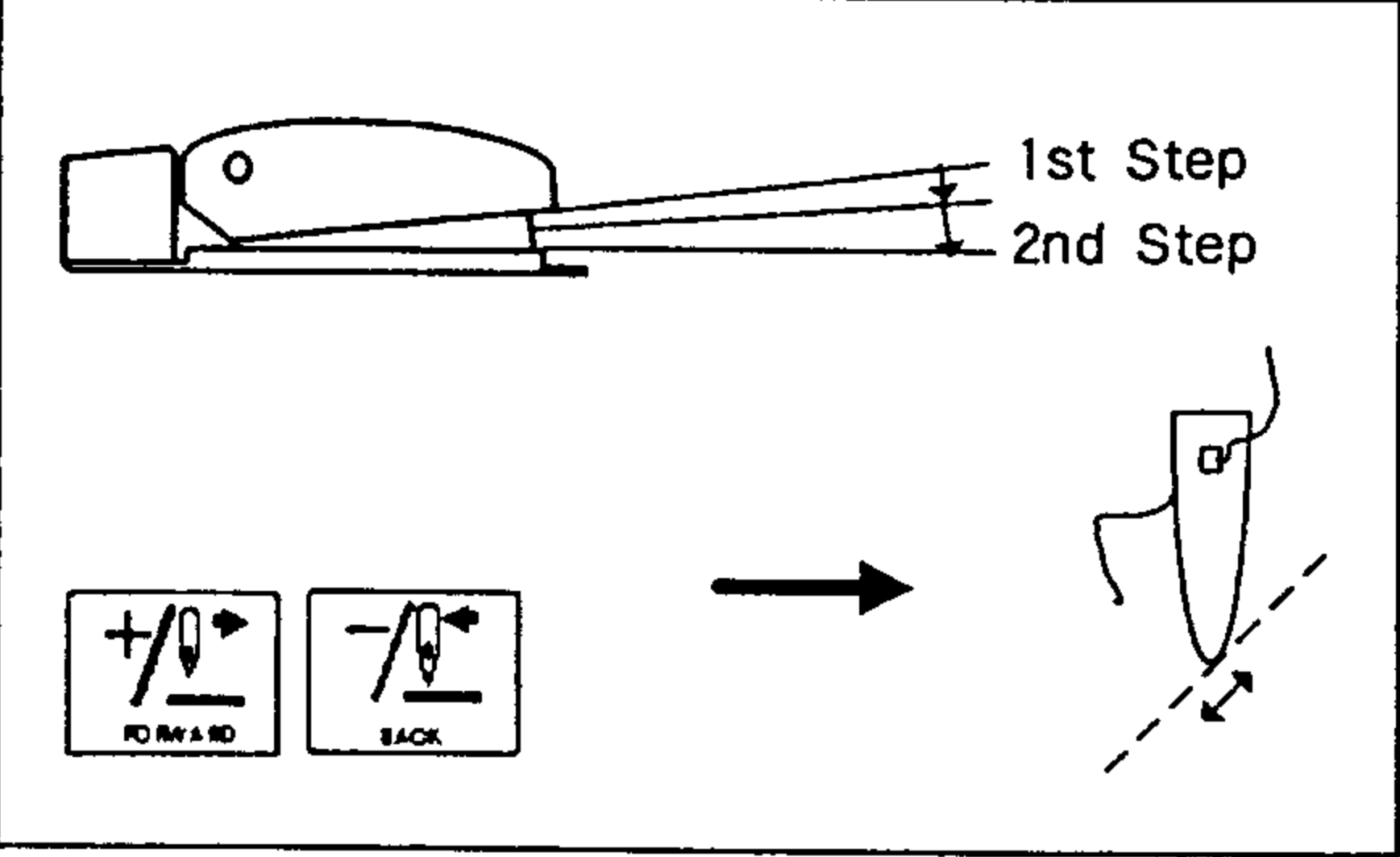

1. On condition that sewing was prepared, step the pedal switch to the step 1 and take down the Pressure Plate.
2. Whenever you press **+/FORWARD** and **-/BACK**, the feeding frame moves to each stitch. During pressing continuously, the feeding frame moves without cease.
3. If you press **Reset**, the needle backs to the sewing start point, then the feeding frame ascends.
 - * When a needle moves for a while, take off your feet from the pedal.

4) Sewing

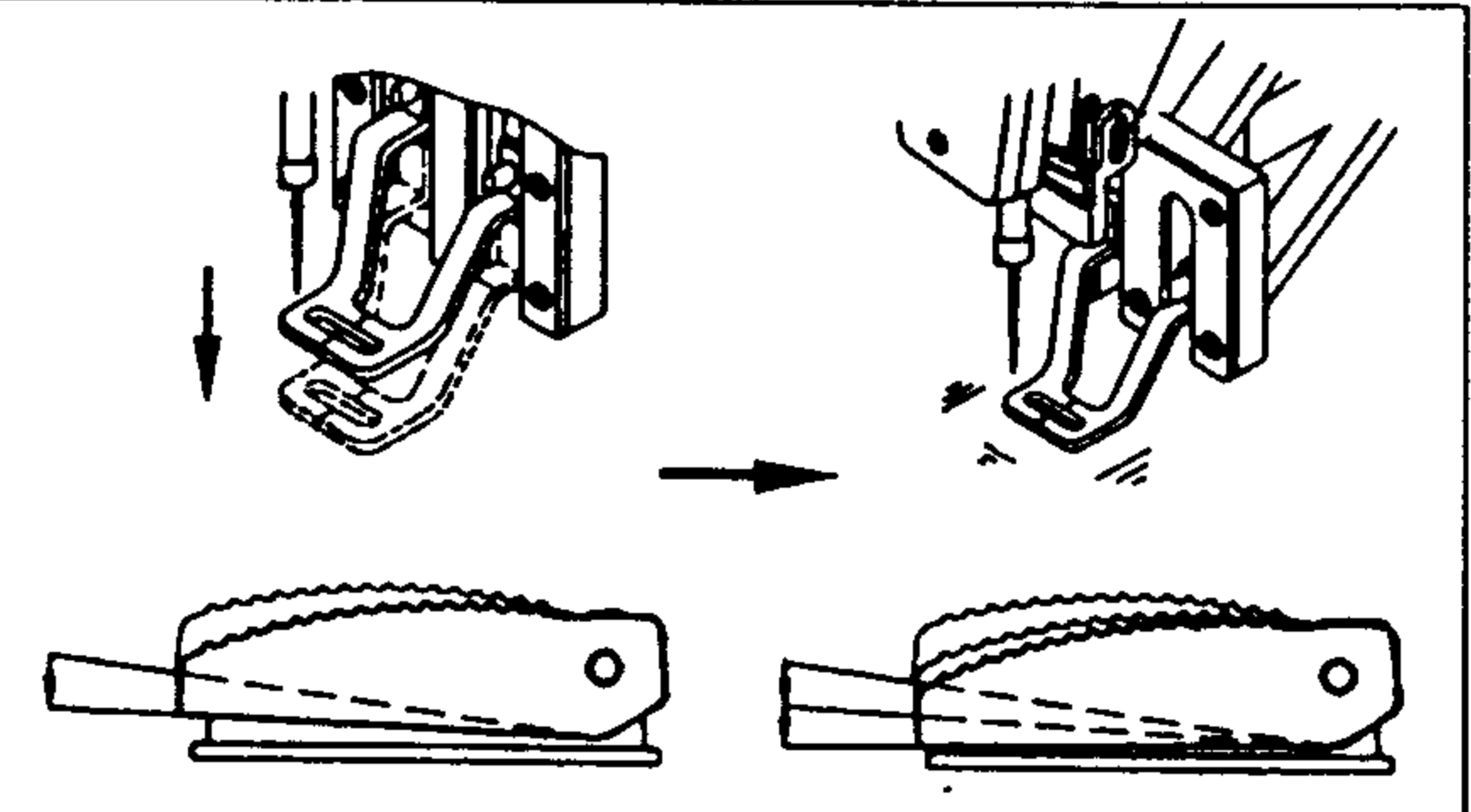

1. Place the sewing materials on feeding frame.
2. If you press a pedal switch to the 1st step, the feeding frame descends. If you take off your feet from the pedal switch, the feeding frame ascends.
3. When the feeding frame is in downward state, if you press pedal switch to the 2nd step, the sewing is started.
4. When finishing sewing, the feeding frame ascends and moves to the sewing start point.

■ Block diagram for standing pedal

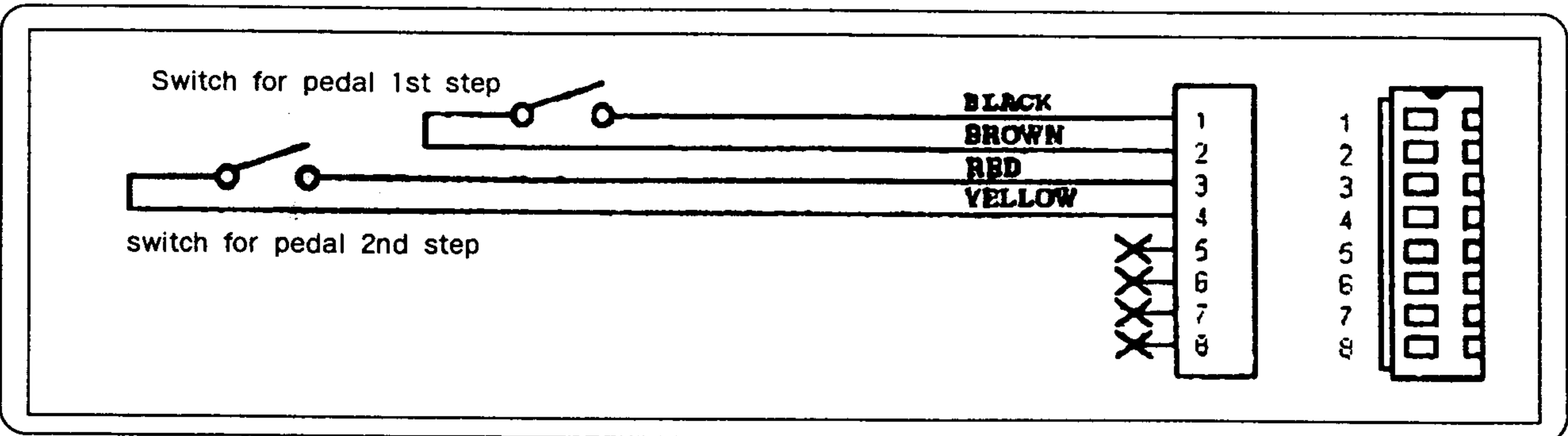

1st step : Feed clamp operation
 2nd step : Machine starts operation

5) Changing the sewing pattern

<input type="radio"/> NO.
<input type="radio"/> X-SCALE
<input type="radio"/> Y-SCALE
<input type="radio"/> SPEED
<input type="radio"/> COUNTER
<input type="radio"/> WINDER
<input type="checkbox"/> SELECT

→

+ / 0
FORWARD

- / 0
BACK

1. Press **Ready**. Then the ready lamp is turned off.
2. Press **SELECT** and make No. item is indicated.
3. Set up 2-(B) ~ (F), moves to the [Confirming the pattern] item.

6) Winding the Bottom Thread

A. When winding is performed during sewing.

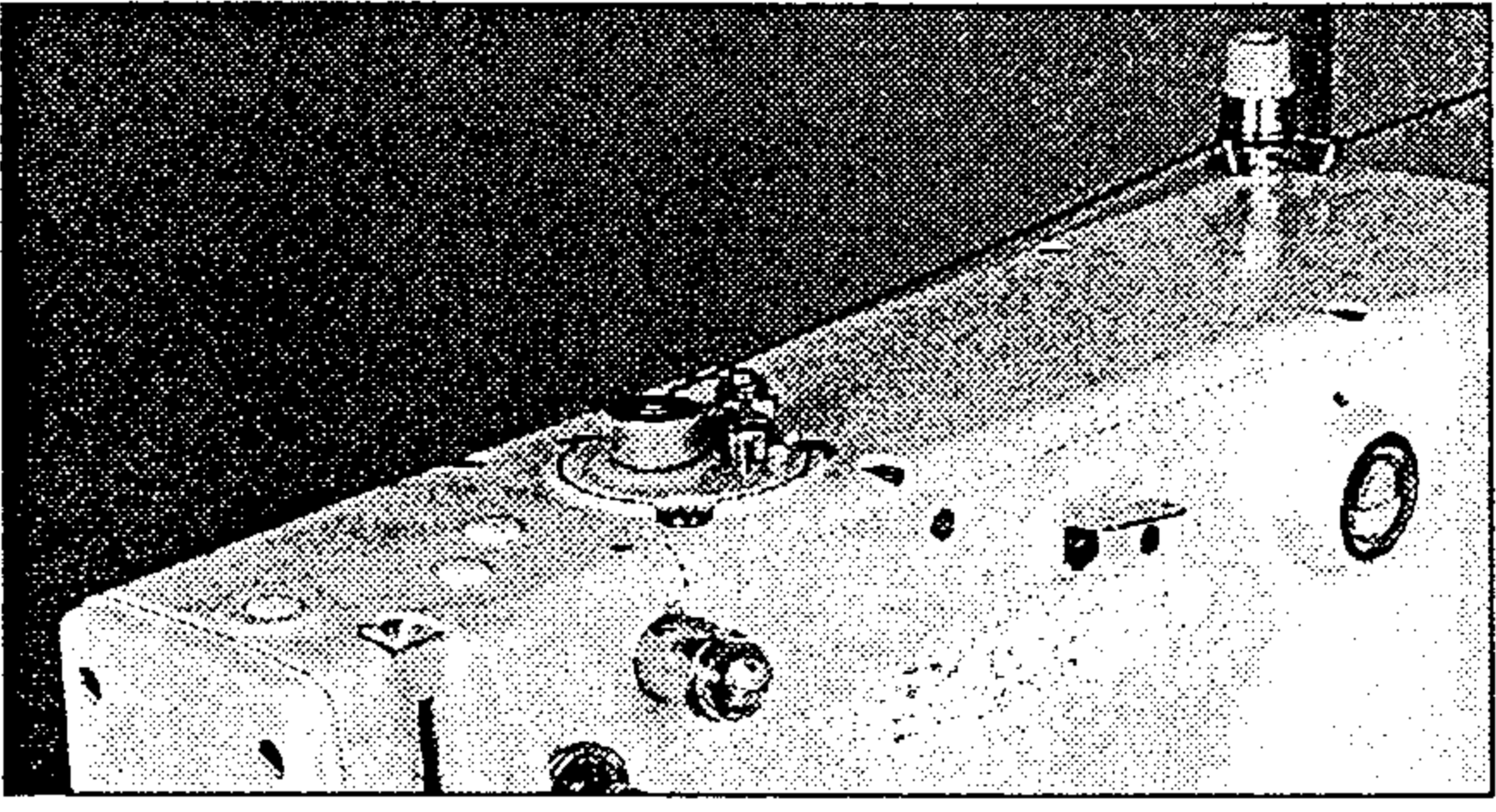

Insert thread as seen in the fig. and wind the bottom thread.

B. When only bottom thread is winded



caution

■ During the bottom thread is winding, the feeding plate does not move, but a needle moves. So, do not put anything under the needle.

<input type="radio"/> NO.
<input type="radio"/> X-SCALE
<input type="radio"/> Y-SCALE
<input type="radio"/> SPEED
<input type="radio"/> COUNTER
<input checked="" type="radio"/> WINDER
<input type="checkbox"/> SELECT

→

bbIn

Ready

1. Press **SELECT** and select WINDER item.
* When the Ready lamp turns on, it can not be selected.
2. Press **Ready**
3. Press a pedal switch to the 2nd step. Then bobbin winder starts thread winding.
4. Press a pedal switch to the 2nd step again, then thread winding is stopped.
5. Press **Ready** to stop thread winding.

2

Operation of Sewing Machine (Application)

1) Using the User's Programs

In programs for users, the 7 different programs (P1~P7) are registered and used.

In the 7 user's programs, the pattern number, the setup of X Enlargement and Reduction rate, the setup of Y Enlargement and Reduction rate, and the sewing speed are registered.

It is comfortable to register the repeatedly-used patterns.

(1) Register of user's programs

Setup example) Register the following items as P1.

Pattern No. : 3
X Enlargement and Reduction rate : 50%
Y Enlargement and Reduction rate : 80%
Limit to sewing speed 1800spm

A. With pressing **SELECT**, turn on the power.



P---

B. Press **A** key.



P1--

C. Press **SELECT** until No. item is indicated.

With **+ / FORWARD** **- / BACK**, set up the pattern No. as 3



3

D. After pressing **SELECT**, using with **+ / FORWARD** **- / BACK**,
set up the X Enlargement and Reduction rate to be 50%,

Y Enlargement and Reduction rate to be 80%, and the sewing speed
to be 1800spm.



50

80

2000

E. By pressing **Ready**, complete the register.

* If you want to register at P2~P7, select P2~P7 in the process
of B and practice the process of C~E.



P---

F. When the register is completed, turn off the power and turn on again.

(2) Selection of user's program

P1 : Press **A**.

P2 : Press **B**.

P3 : Press **C**.

P4 : Press **A** and **B** at the same time.

P5 : Press **B** and **C** at the same time.

P6 : Press **A** and **C** at the same time.

P7 : Press **A**, **B** and **C** at the same time.

* When selecting P4,P5,P6 and P7, combine **A**, **B**, **C** keys.

(3) Operation of Sewing

Operation example) Sew the registered contents of P1, then the contents of P3.

- A. Turn on the power.
 - B. Press **A**.
 - C. By pressing **Ready**, the Ready lamp is turned on, then a feeding plate ascends after movement.
 - D. Confirm the patterns. (Refer to the 「Confirming the Pattern」)
 - E. If the result of confirmation on the patterns is good, sewing can be available.
 - F. After completing sewing, if you press **C**, the feeding plate moves to the sewing start position after moving the origin. (By using function keys, the change of pattern is available with only a key operation although the Ready lamp is turned on.)
 - G. Performs D. and E. process above.
- ※ P1~P7 is indicated when changing patterns by pressing **+ / FORWARD** and **- / BACK**.

→ 0 to 99 ↔ P1 to P7 ← Unregistered P1~P7 are not indicated.

2) Sewing to use the function of Combination

It is available to change patterns in the orders whenever sewing is completed by arranging the already registered users' program in Cnb1, Cnb2 and Cnb3.

※ The maximum combination of P1~P7 available to register in Cnb1, Cnb2 and Cnb3 are 15.

(1) Register of Combination

Setup example) Register in the order of P1, P2 and P3 with combining in Cnb1.

A. With pressing **A** and **SELECT**, turn on the power.



Cnb1

B. After pressing **SELECT**, press **A**.



1-P1

C. After pressing **SELECT**, press **B**.



2-P1

D. After pressing **SELECT**, press **C**.



3-P1

E. By pressing **Ready**, complete the register.



Cnb1

F. If the power is turned on in the process off.

※ ① If the power is on in **A** process, press **B** or **C** and **SELECT**. If you press B, the register comes to be Cnb2, and press **C**, the register comes to Cnb3.

※ ② If you want to register P4~P7, press **A**~**C** at the same time.

※ ③ 10~15 are indicated as A~F.

[Caution]

Patterns not registered in Function key (P1~P7) can not be combined.

(2) Operation of Sewing

A. Turn on the power.

B. With **+ / FORWARD**, **- / BACK** key, Make the pattern No. as "C1-1 ~ C3-F".

Change like followings when the key is pushed.

→ 0 to 99 ↔ P1 to P7 ↔ C1-1 to C3-F ←

* P1 ~ P7, Cnb1 ~ Cnb3 not registered are not indicated.

C. By pressing **Ready**, the Ready lamp is turned on, then a feeding plate ascends after movement.

D. If the result of confirmation on the patterns is good, sewing can be available.

E. Whenever the sewing is completed, each stage is made according to the combination.

When a sewing in a cycle is completed, it goes to the initial stage. Sewing is repeated.

* ①. During sewing, if you want to back to the previous or goes to the next stage, when ready lamp is turned on, press **+ / FORWARD**, **- / BACK**.

The contents of indication in No. item comes to change, and the feeding plate moves to the initial point of sewing.

* ② If the contents of P1 ~ P7 are changed after registering the Cnb1 ~ Cnb3, great attention should be paid since the contents of P1 ~ P7 used in Cnb1 ~ Cnb3 are changed.

* ③ Confirm each pattern. (Refer to 「Confirming the pattern」)

* ④ Within one item (for example, Cnb1), a pattern will be changed into next pattern automatically.

3) Sewing Used with Bottom Thread Counter

The counter for working capacity can be used as Bottom Thread Counter. In case of sewing with same pattern is repeated, when the quantity reaches the number that one bobbin can sew, the machine stops working. At this time, the bottom thread counter should be setup decreasing type.

[Caution]

The machine is set up as working capacity counter system (Increment type) when factory- installed. When the bottom thread counter is installed, the memory switch should be changed. (Refer to 「Use of Memory Switch」)

A. Press **SELECT** when the ready lamp is turned off to "COUNTER" should be indicated.

B. Press **Reset** key.

C. Press **+ / FORWARD**, **- / BACK** to set up sewing available times with a bobbin.

D. After completing each sewing, the counter value decreases each.

E. When the sewing is completed as much as setup times, the machine does not work even pedaling.

F. After exchanging into new bobbin, press **Reset**.

G. Repeat D. ~ F.

4) Cautions

- A. When inserting the thread or running the machine, start sewing after the thread tension plate is closed.
- B. In case of turning on the error lamp, take up proper measure according to the cause of trouble.
- C. Do not pull the sewing materials during running, since the position of needle is distorted. In that case, press **Ready** key twice to make the needle locate in right position.
- D. Do not turn off the power when the needle is descending.

■ Sewing speed according to materials

	Speed (SPM)
Denim 8pcs	Below 2,200 ~ 2,700
Denim 12pcs	Below 2,200 ~ 2,500
Clothes	Below 2,200 ~ 2,700
Clothes (Synthetic)	Below 2,000 ~ 2,300
Knit	Below 1,800 ~ 2,000
Underclothes	Below 1,800 ~ 2,000

- E. To prevent from thread cutting by heat, set up properly the sewing speed according to sewing materials referring to the above table.
- F. When sewing materials such as underclothes, lower the height of needle bar to prevent from stitch jumping. (Refer to 「Adjusting the Height of Needle Bar」)

3

How to Use the Memory Switch

1) Running the Memory Switch

The function of memory switch is divided into two groups. One is the general sewing related function to change general operation of sewing machine, the other is the control related one to change the operation of servo motor.

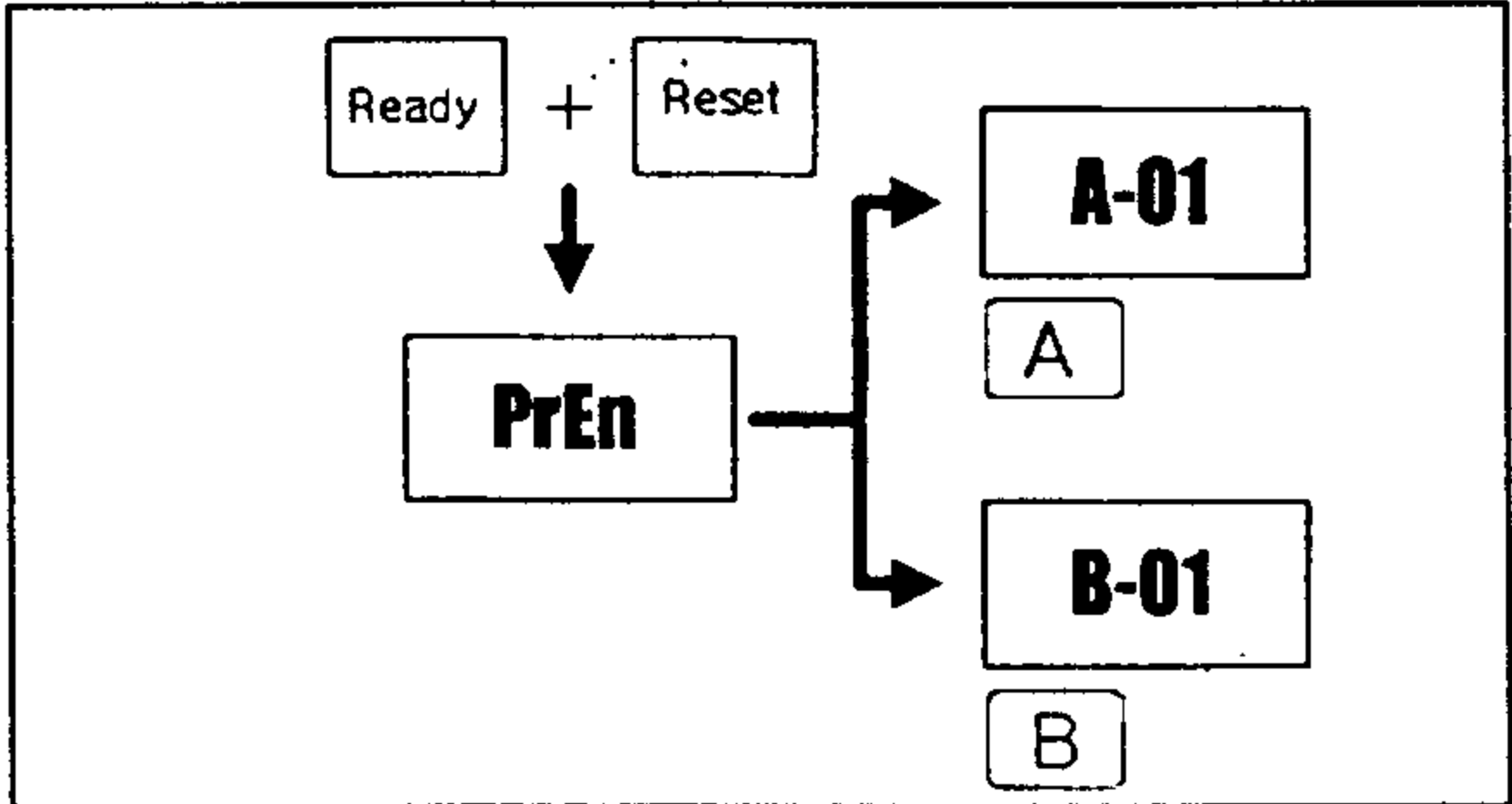

1. Turn on the power with pressing **Ready** and **Reset**.
2. Press **A** to change the general sewing related function.
3. Press **B** to change the servo motor related function.

2) Examples of Setting up the Memory Switch

(1) Upper Limit Setup of Sewing Speed

Ex) Change 2000spm to 1800spm.

1. Press **+ / FORWARD** to make "A-01" appears on the screen after running memory switch. A - 01

2. If you press **Ready**, the present setting value is indicated. 2000

3. Press **- / BACK** to change the setting value into "1800" 1800

4. Register it with **Ready**. A - 01

(2) Setting up the Soft Start Speed for start sewing

The speed for 1~5 stitches for start sewing can be changed with a unit of 100 spm.

	Setup Range	Initial Setup
The 1st Stitch	100~900	400 spm
The 2nd Stitch	100~2,000	900 spm
The 3rd Stitch	100~2,000	1,800 spm
The 4th Stitch	100~2,000	1,800 spm
The 5th Stitch	100~2,000	1,800 spm

The value above can be varied according to the machine type.

[Caution]

A 01, the general sewing related function (Upper Limit setup Sewing Speed) has priority.

Ex) Change the 1st stitch from 400 into 900, and the 2nd stitch from 900 into 1,200.

A. After running the memory switch,

Press **+ / FORWARD** to make "A-02" appear on the screen.

A-02

B. Press **Ready** to set up present setting value.

(The 1st stitch speed, 400 spm is indicated.)

1-04

C. Press **+ / FORWARD** to make "1-09" appear on the screen.

(change into 900 spm.)

1-09

D. Press **SELECT**.

(The 2nd stitch speed, 900 spm is indicated.)

2-09

E. Press **+ / FORWARD** to make "2-12" appear on the screen.

(Change into 1,200 spm.)

2-12

F. Register it with **Ready**.

A-02

(3) Setting up the pattern Data Calling

It makes the unneeded pattern calling impossible to prevent from calling of unavailable pattern by mistake. In addition, it possible to call needed pattern to use.

Ex) It makes calling of pattern 1,2 impossible.

<p>A. After running the memory switch. Press + / FORWARD to make "A-03" appear on the screen.</p>	<p>A - 03</p>
<p>B. Press Ready to set up present setting value. Indication Ⓐ : Pattern No. Indication Ⓑ : 0 : Calling impossible 1 : Calling possible</p>	<p>01 - 1 Ⓐ Ⓑ</p>
<p>C. Press - / BACK to change indication Ⓑ from "1" into "0".</p>	<p>01 - 0</p>
<p>D. Press SELECT to change indication Ⓐ from "1" into "2".</p>	<p>02 - 1</p>
<p>E. Press - / BACK to change indication Ⓑ from "1" into "0".</p>	<p>02 - 0</p>
<p>F. Register it with Ready.</p>	<p>A - 03</p>

(4) Setting up the Counter Operation

Ex) Production counter(Increment type) changes into Bobbin Thread Counter(Decrement type).

<p>A. After running the memory switch, Press + / FORWARD to make "A-05" appear on the screen.</p>	<p>A - 05</p>
<p>B. Press Ready to set up present setting value.</p>	<p>Ⓐ</p>
<p>C. Press + / FORWARD to change indication Ⓐ from "0" into "1" Indication Ⓐ : Pattern No. : 0 : Product Counter : 1 : Bobbin Counter</p>	<p>0</p>
	<p>1</p>
<p>D. Register it with Ready.</p>	<p>A - 05</p>

(5) Selecting Upper Thread Holding Device Function

Please change parameter to use upper thread tension adjusting function in pneumatic type.

A. After running the memory switch press +/FORWARD to make "A-32" appear on the screen.	A - 32
B. Press READY to set up present setting value. Indication @ Part: 0: Not use holding device 1: Use holding device	@
	0
C. Press +/FORWARD to change indication @ from "0" into "1".	1
D. Register it with READY key.	A - 32

(6) Selecting Method of Serial/Separate Type Pedal

Please change parameter to use separate type of pedal in HA-22 Model.

Ex) When using separate type pedal	
A. After running the memory switch, Press +/FORWARD to make "A-33" appear on the screen.	A - 33
B. Press READY to set up present setting value. Indication @ Part: 0: Monolithic type pedal 1: Separate type pedal	@
	0
C. Press +/FORWARD to change indication @ from "0" into "1".	1
D. Register it with READY key.	A - 33

Note: If you want to use separate type pedal as series type pedal, change indication **@** "1" → "0" by pressing **-/BACK** when going from step B to step C. Register with **READY** key.

3) Function Chart of Memory Switch (A Group)

1) Turn on the power with pressing **Ready** and **Reset** simultaneously, then operate it by pressing **A**.

NO.	Function and Description	Setup Range	Initial Setup	Unit
A-01	Upper Limit of Sewing Speed	Normal Materials: 100~2700 Heavy weight materials: 100~2700 Thin materials: 100~2000 Kint: 100~2000 Pneumatic type: 100~2200 Button Sewing: 100~2500	2300 spm 2300 spm 1800 spm 1800 spm 1800 spm 2200 spm	100 spm
A-02	Set the speed of 1-5 stitches of sewing start (soft start set, different by machine type)	1 stitch : 100~900 2 stitch : 100~2000 3 stitch : 100~2000 4 stitch : 100~2000 5 stitch : 100~2000	400 spm 900 spm 1800 spm 1800 spm 1800 spm	100 spm
A-03	Set whether to call the patter data (Available to set each pattern individually)	0: Calling Impossible 1: Calling Possible	1201 Series 1~22:1 23~99:0	1202 Series 1~33:1 34~99:0
A-04	Set X and Y extension and reduction rate, indication of maximum speed limit and possibility of change(prevention of wrong operation)	0 : Impossible 1 : Possible	1	
A-05	Set the counter action Production Counter: addition counter Lower Thread Counter: reduction counter	0 : Addition counter 1 : Deduction counter	0	
A-06	Set the datum point of extension and reduction	0 : Origin 1 : Sewing Start Position	0	
A-07	Set whether to practice retrieval of original point after completion of sewing (in case of sewing by normal pattern number)	0 : Not performed 1 : Performed	0	
A-08	Set whether to practice retrieval of original point after completion of sewing (in case of sewing by function combination)	0 : Not performed 1 : Performed	0	
A-09	Set the standard of extension and reduction.	0 : Unlimited 1 : Limit to feeding range	1	
A-10	Set the start angle of XY transfer	0~255°	0°	1°
A-11	Set the thread trimmer speed	200~400spm	400spm	1000spm
A-12	Set the reverse rotation after thread trimming	0 : Not performed 1 : Performed	0	
A-13	Set the reverse rotation after thread trimming	0~70°	0°	1°
A-14	Set whether to call the electronic wiper	0: Calling impossible 1:Calling Possible	0	
A-15	Function to reduce raising time of presser foot after thread trimming	0 : Not performed 1 : Performed	1	
A-16	Function to retrieve the original point after work of a certain time (Retrieve the original point after working as many as the times set at A-17)	0 : Not performed 1 : Performed	0	
A-17	The number of work for retrieval of original point	0~1000	1000	4
A-18	Set the ON time of electronic wiper	4~1020ms	100ms	4ms
A-19	Function to cancel thread trimming	0 : Not performed 1 : Performed	0	
A-20	Presser Plate Solenoid Full On Time	4~1020ms	100ms	4ms
A-21	Thread Trimmer Solenoid Full On Tim	4~1020ms	100ms	4ms
A-22	Auxiliary Solenoid Full On Time	4~1020ms	100ms	4ms
A-23	Wiper Solenoid Full On Time	4~1020ms	100ms	4ms
A-24	Presser Plate Solenoid Duty	1~25%	10%	1%
A-25	Thread Trimmer Solenoid Duty	10~25%	20%	5%
A-26	Auxiliary Solenoid Duty	10~25%	20%	5%
A-27	Wiper Solenoid Duty	10~25%	20%	5%
A-28	Presser Plate Solenoid Rise Detecting Time	4~1020ms	HA type	Other M/C type
A-29	Presser Plate Solenoid Drop Detecting Time		100ms	500ms
A-30	Set the Off-Time of Electronic Wiper	4~1020ms	40ms	4ms
A-31	Set Up/Down After Trimming	0: down 1: Up	1	
A-32	Set Whether to practice retrical the upper thread holding device in pneumatic type	0: Not Pertormed 1: Pertormed	0	
A-33	Set Whether to select by monolithic and separte type pedal	0: Monolithic Type 1: Separete Type	0	

2) Function Code related servo motor control (B Group)

After turning on the power with pressing **Ready** and **Reset** simultaneously, operate it by pressing B.

N0.	Function and Description		Name fo Function		Setup Range		Initial State	Unit
B-01	Position sensing speed to stop		Pos-spd		2 ~ 510		220spt	2spt
B-02	Speed right before stop		end spd2		0 ~ 255		16spt	1spt
B-03	Delay time to place rightly at stop position		Stop Delay		4 ~ 1020		80ms	4ms
B-04	Sensing distance of the 1st position		DIST1		0 ~ 255		150Pulse	1Pulse
B-05	Distance benefit A		KC1A		0 ~ 255		10	1
B-06	Distance benefit B		KC1B		0 ~ 255		2	1
B-07	Destance benefit C		KC1C		0 ~ 255		10	1
B-08	Whole level on distance benefit		KC2		0 ~ 255		100	1
B-09	Speed benefit A		KF1A		0 ~ 255		160	1
B-10	Speed benefit B		KF1B		0 ~ 255		80	1
B-11	Speed benefit C		KF1C		0 ~ 255		180	1
B-12	Velt Type	Direct Type	Velt Type	Direct Type	Velt Type	Direct Type	100	1
	Whole level on speed benefit		Speed Unit	KF2	Spd-unit	0 ~ 255		
B-13	Power when pulley is fixed		KH1		10 ~ 100		40	1
B-14	Repairing distance when pulley is fixed		KH2		10 ~ 100		20	1
B-15	Reduce rate from stop signal to position sensing speed		accelA		2 ~ 100		54	1
B-16	Speed decrease rate (the more the faster reduce)		accelB		10 ~ 100		80	1
B-17	SpeedReduce Rate (Larger Late Faster Decreased)		accelC		10 ~ 100		30	1
B-18	Speed increase rate (the more the faster acceleration)		accelD		2 ~ 100		4	1
B-19	Inertia of Sewing Machine		Inertia		0 ~ 255			Not in use
B-20			SPMUPPER					Not in use
B-21			UPPosition					Not in use
B-22			IND-REFM					Not in use
B-23			TRStartM					Not in use
B-24			TREndM					Not in use
B-25	Sewing machine pulley size		PULY-SIZEN					Not in use
B-26			CutSartM					Not in use
B-27			CutEndM					Not in use
B-28	Synchronizer sensor sensing time		SlockTmM		5 ~ 1275		40×0.1	0.5s
B-29	Overload sensing time		OvLoadM		5 ~ 1275		30×0.1	0.5s
B-30	Sewing machine pulley fix En/Dis		HOLD-FG		0: Disable 1: Enable		0: Disable	
B-31	Servo motor rotary direction		DIR-MODE		0: Reverse 1: Forward		1: Forward	
B-32	Sensing Time of Origin Sensor		Orgtm		4 ~ 1020		500	4ms

※ Description on shade area

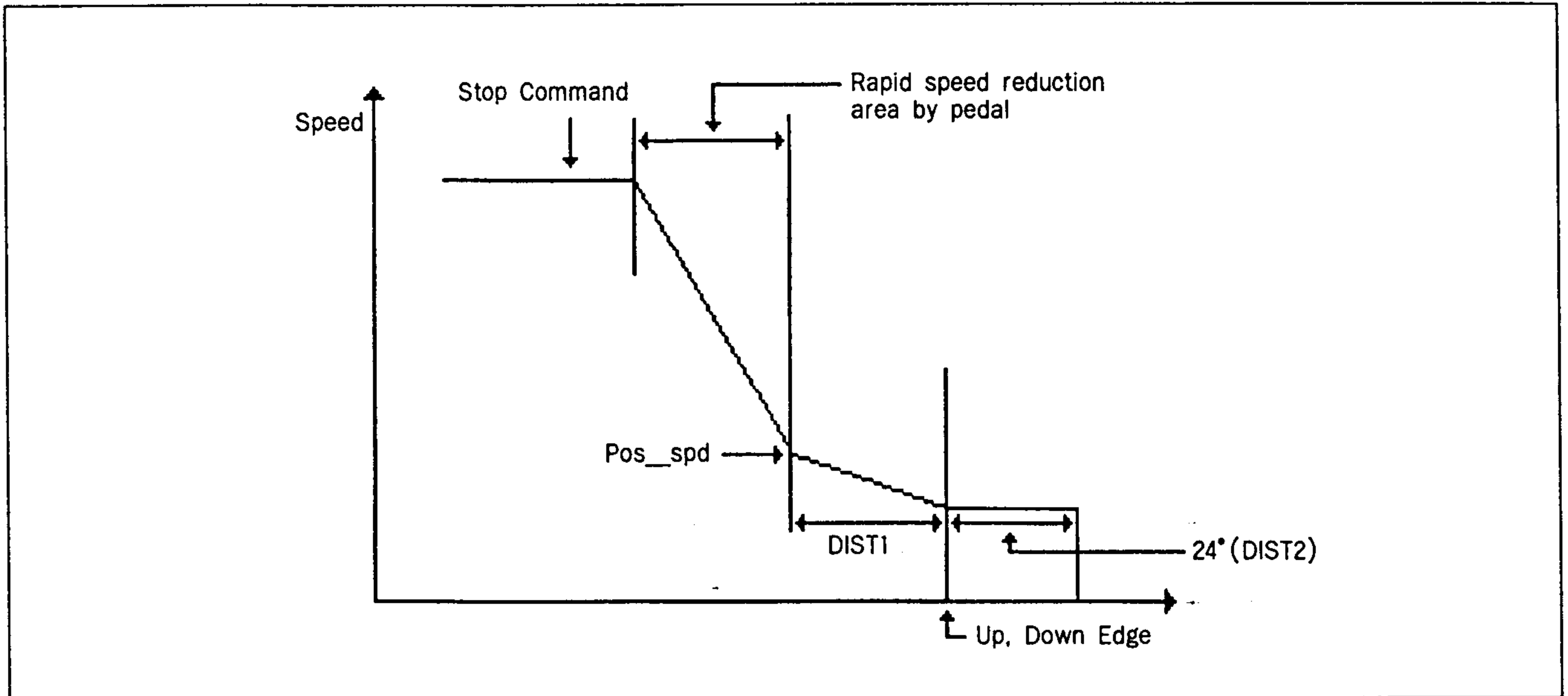

- B-04 (DIST1) : The figure shows the position that rapid speed reduction is completed when stop working.
Stable rapid speed reduction can be made as the figure increases.
- B-08 (KC2) : It can be saved by inertia turning, and chase to distance gets slower as this figure increase.
(General user and engineer are not permitted to use.)
- B-12 (KF2) : It can be saved by inertia trning, and chase to distance gets slower as this figure increases.
(General user and engineer are not permitted to use.)
- B-15 (accelA) : It can be saved by inertia tuning, and it is a speed reduction until rapid speed reduction is completed after inputting stop signal of pedal. The more this value increases, the less rapid speed reduction is made, but if the value extremely increase, the rapid speed reduction can not be available.
- B-16 (accelB) : It shows the value how rapidly the speed increases during the accelerating by pedal, and the acceleration to the aim speed gets faster, but speed change at the reaching aim speed can be increased.
- B-17 (accelC) : It shows the value how rapidly the speed increases during the decelerating by pedal, and the speed reduction to the aim speed gets faster, but speed change at the reaching aim speed can be increased.

※ Example to use the function in shade area

- ① When the emergency stop is not easily available and one more stitch is proceeded.
 - This case is occurred when the sewing machine drives in very high speed or rapid speed reduction in short time is not available owing to the overload of sewing machine. Increase the value of B-04 and B-15 properly.
- ② During increasing or decreasing the sewing speed, the time that motor follows speed is slow
 - This case can be occurred when the increase and decrease rate is less than increase and decrease load of sewing machine. Increase the value of B-16 and B-17 properly.

4

The Rest

1) Testing the Machine

It is available to check each part of sewing machine. If the machine does not work normally, take follow-up measure after checking the cause of trouble in electric system.

※ After running the function of machine test if you want to move to other item of machine test, press **SELECT**, then press **+/FORWARD** and **-/BACK**.

(1) Operation of machine test

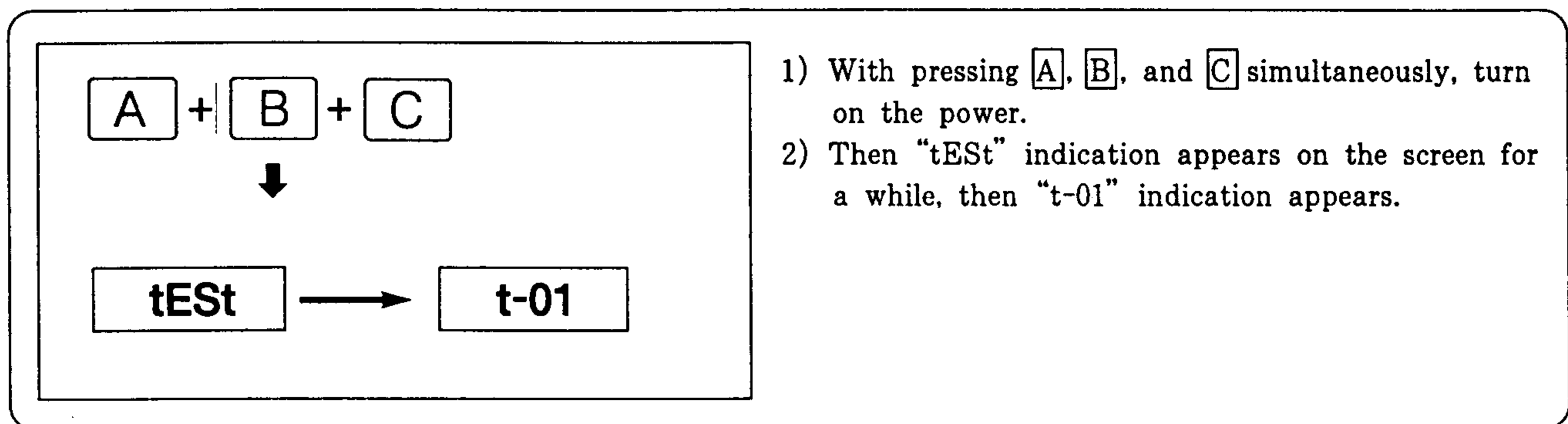

(2) Move the step motor and origin sensor test

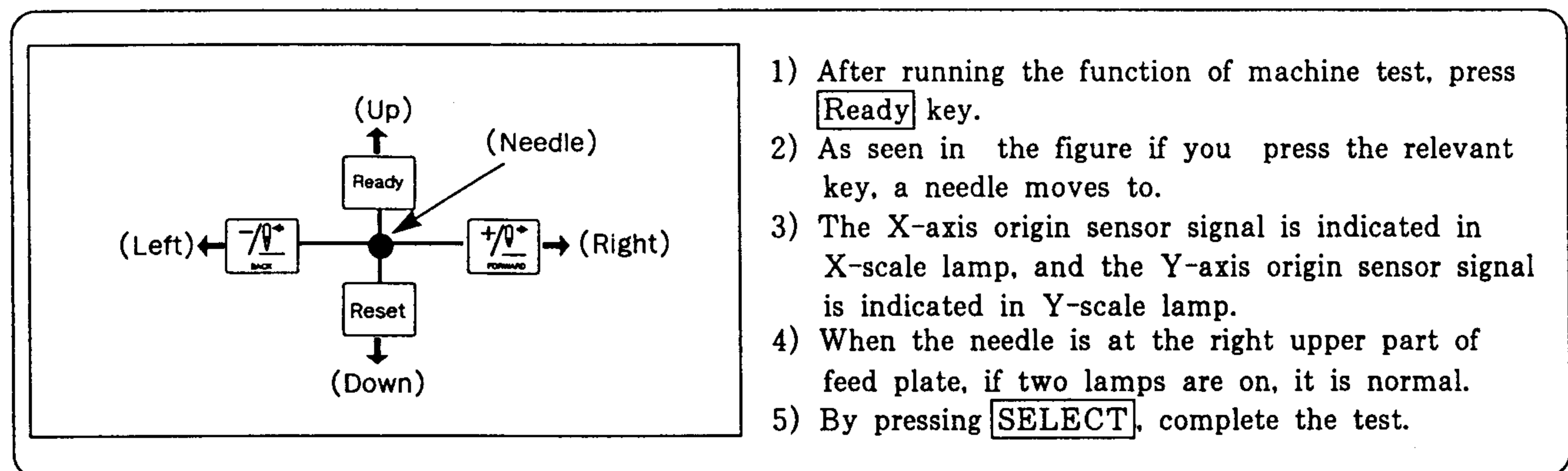

(3) Solenoid Test

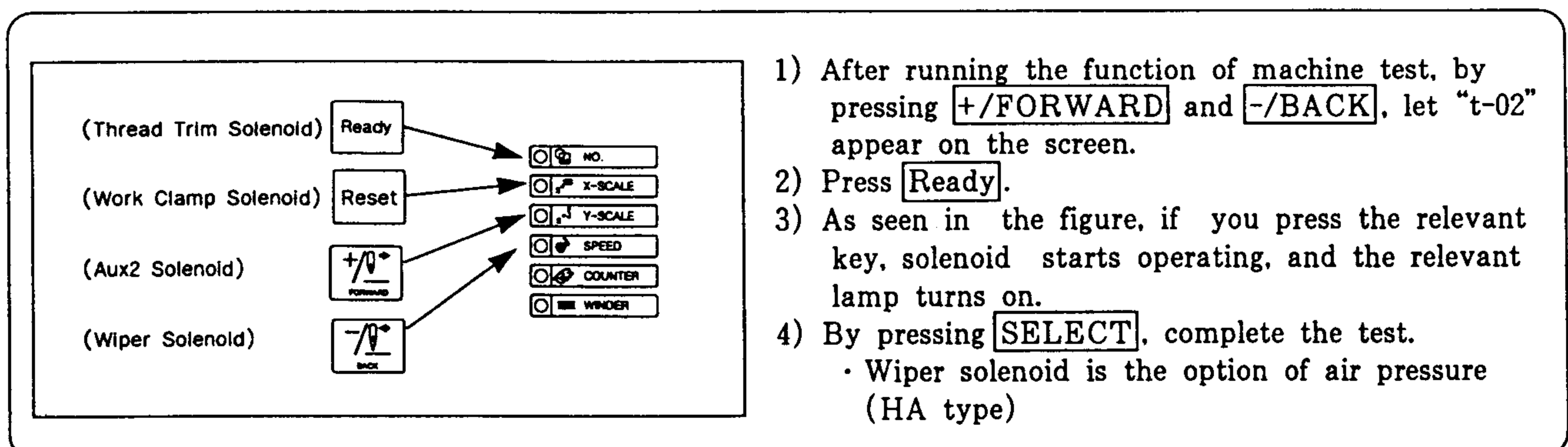

(4) Main Motor Test

(Main Motor Run/Stop) Ready

(Increase the speed) + / /

(Decrease the speed) - / /

1200

 (Motor Speed)

- 1) After running the function of machine test, by pressing + / FORWARD and - / BACK, let "t-03" appear on the screen.
- 2) Press Ready.
- 3) If you press Ready, motor starts running. The speed of main motor is indicated on the window. If you press Ready again, the machine stops operating.
- 4) Adjust the speed with + / FORWARD and - / BACK.
- 5) By pressing SELECT, complete the test.

(5) Encoder Test

135

 (Encoder Angle)

- 1) After running the function of machine test, by pressing + / FORWARD and - / BACK, let "t-04" appear on the screen.
- 2) Press Ready.
- 3) If you turn pulley manually, the encoder angle is indicated on the window, and NO lamp turns on.

◀Note▶ If the value is not changed, there may be a problem in encoder including connector.

- 5) By pressing SELECT, complete the test.

(6) Synchronizer Test

5

 (No. of Circulation)

- 1) After running the function of machine test, by pressing + / FORWARD and - / BACK, let "t-05" appear on the screen.
- 2) Press Ready.
- 3) If you turn pulley manually, the time of circulation is indicated on the window and the synchronizer signal is indicated on No. lamp.

◀Note▶ If the value is not changed although you turn more than one time, there may be a problem in synchronizer including connector.

- 5) By pressing SELECT, complete the test.

(7) Pedal Input Test

(1st Step) →

(2nd Step) →

Aux1 Switch →

Aux2 Switch →

NO.
X-SCALE
Y-SCALE
SPEED
COUNTER
WINDER

- 1) After running the function of machine test, by pressing + / FORWARD and - / BACK, let "t-06" appear on the screen.
- 2) Press Ready.
- 3) If you press pedal to the 1st step, the NO lamp turns on, and pedal to the 2nd step, the X-SCALE lamp turns on. If you press Aux1 switch, the Y-SCALE lamp turns on, and press Aux2 switch, the SPEED lamp turns on.
- 4) By pressing SELECT, complete the test.

(8) Auxiliary Output Test

(Aux. output On/Off)

Ready

(End of test)

SELECT

- 1) After running the function of machine test, by pressing **+/FORWARD** and **-/BACK**, let "t-07" appear on the screen.
- 2) Press **Ready**.
- 3) If you press **Ready** the 8 Aux. outputs (J11 on digital circuit board) turn on, then if you press **Ready** one more time, all turn off.
- 4) By pressing **SELECT**, complete the test.

(9) Auxiliary Input Test

Aux8 Input	→		READY
Aux7 Input	→		?
Aux6 Input	→		ERROR
Aux5 Input	→		NO.
Aux4 Input	→		X-SCALE
Aux3 Input	→		Y-SCALE
Input of air pressure drop	→		SPEED
User program external change input	→		COUNTER
			WINDER

- 1) After running the function of machine test, by pressing **+/FORWARD** and **-/BACK**, let "t-08" appear on the screen.
- 2) Press **Ready**.
- 3) According to the signal of the 8 Aux. (J9 of digital board) input, the relevant lamp turns on.
- 4) By pressing **SELECT**, complete the test.
 - Use the input of air pressure drop in case the machine is pneumatic type.

(10) Step Motor Jump Test

(Test Run/Stop)

Ready

10

(Times of test)

(Increase the times of test)

+/FORWARD

(Decrease the times of test)

-/BACK

- 1) After running the function of machine test, by pressing **+/FORWARD** and **-/BACK**, let "t-09" appear on the screen.
- 2) Press **Ready**.
- 3) If you press **Ready**, the machine stops after testing 10 times automatically.

◀Note▶ By using **+/FORWARD** and **-/BACK**, the times of test can be changed.
- 4) By pressing **Reset**, complete the test.

2) Using Other Function

(1) Initialization of Memory Switch

It is the function to return the setting of memory switch that the user has changed to the shipping status.

Reset

+

+/FORWARD

+

-/BACK

↓

Init

- 1) Turn the power on pressing **+/FORWARD**, **-/BACK**, and **Reset key** at the same time.
- 2) If the following screen appears, return the memory switch setting to factory shipping status.
- 3) After a moment, it returns to the initial screen.

◀Note▶ Pay attention that the memory switch setting that the user has changed should not be erased.

(2) Inertia Tuning

The controller automatically practices inertia tuning to meet the load of machine.

Please don't use unless tracing of sewing speed is too late or inner stitch goes faster.

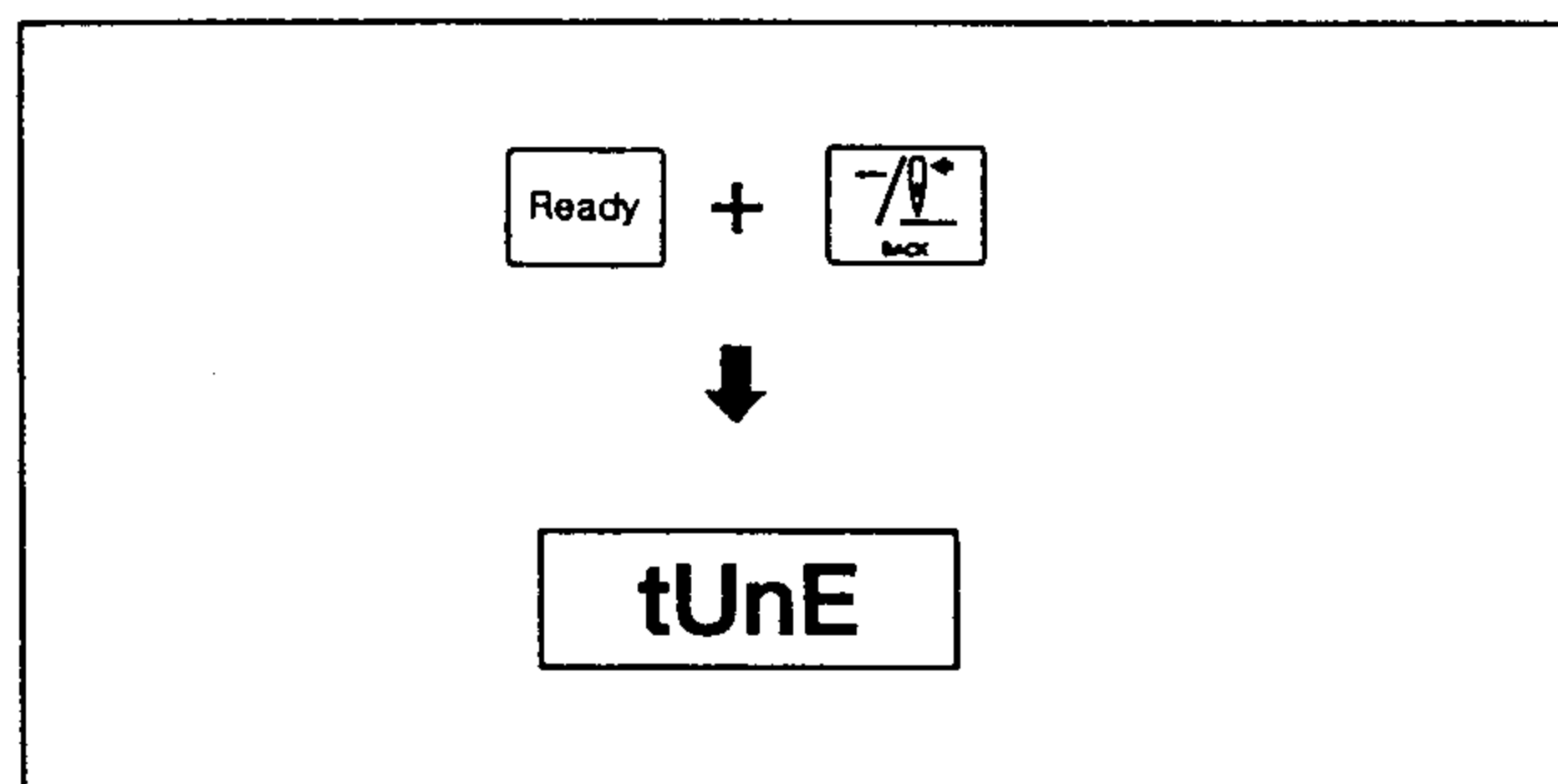

1. Turn the power on while pressing **Ready** and **-/Back** key at the same time.
 2. Then the following screen shall appear.
 3. If you step on the foot plate switch up to step 2, automatically inertia tuning is practiced.
- ※ As the needle bar stops at a temporary location after practice of inertial tuning, turn off the power after placing the needle bar at the right location and then turn the power on again.

(3) Check Program Version

If you turn the power on, the following screen appears for about 0.5 seconds and disappears, and here, dH indicates machine model and 11 indicates the version in the ROM side figure.

dH11

Model	Item	"Er05" presser foot error	air pressure use,	"Er07" air pressure error	Maximum sewing speed	Version indication in case of power on	
						Direct Type	Belt Type
B1202	Button Sewing	○	×	×	2500[spm]	db11	bb11
B1201 H	For Heavy	○	×	×	2700[spm]	dH11	bH11
B1201 M	For Normal	○	×	×	2700[spm]	dN11	bN11
B1201 L	For Thin	○	×	×	2000[spm]	dL11	bL11
B1201 K	For Kint	○	×	×	2000[spm]	dh11	bh11
B1201HA	For Heavy	×	○	○	2200[spm]	dA11	bA11

3) ROM Mounting and Changing

(1) Type and classification of ROM

- ① Extension Pattern ROM: As the ROM input the sewing pattern manufactured to meet the user's request, it is not mounted at the time of factory shipping. Upon request of user, it is separately dispatched and mounted for use.

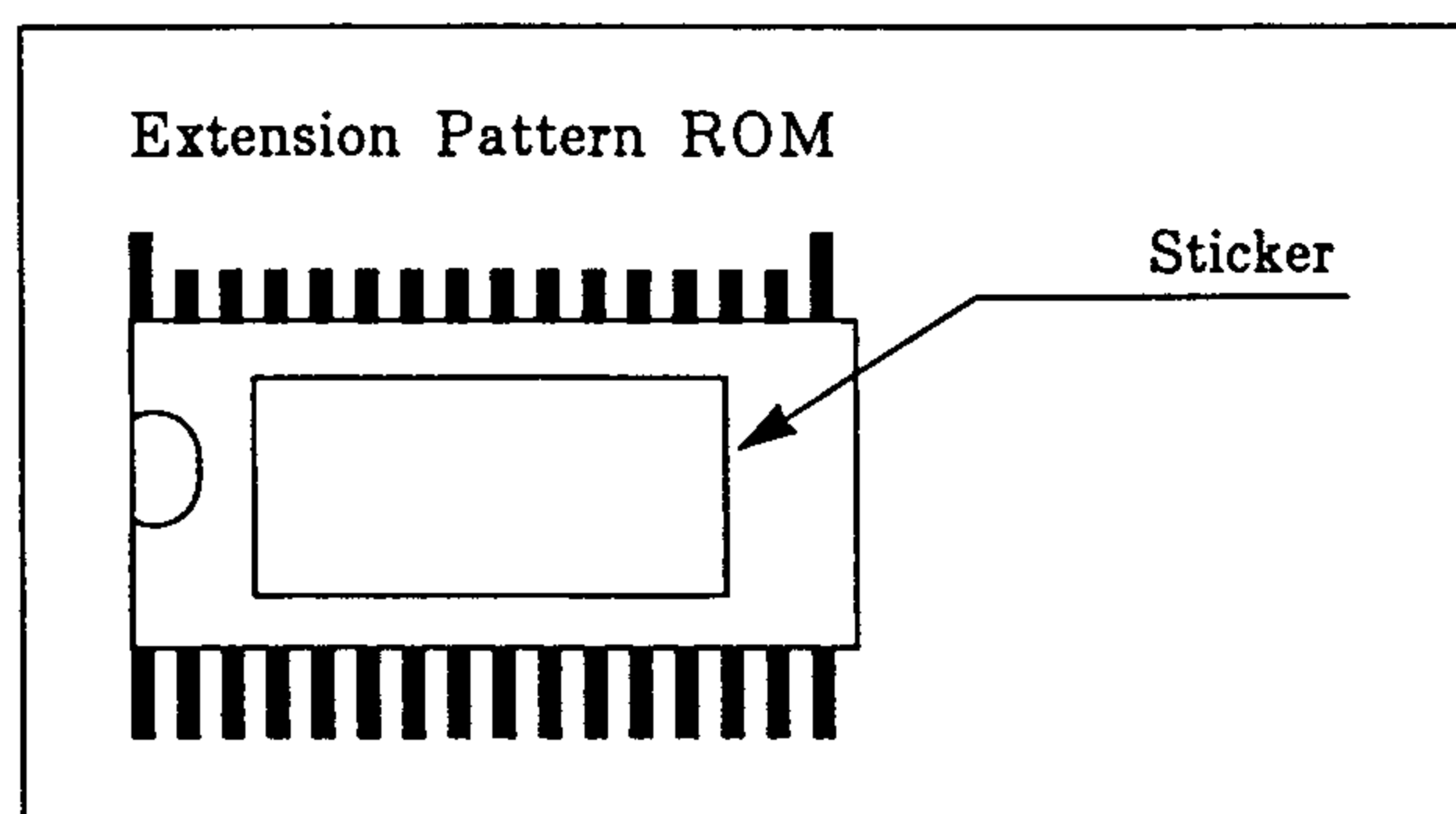

- Sticker Indication: Generally indicate by eight figures, but indication differs by design.
Ex) bc000928, bj000390...

② Program ROM: As the ROM input the program required to operate sewing machine, it is basically mounted at the time of factory shipping. However, in case of adding or changing the function, you should replace with new version of program ROM and use it.

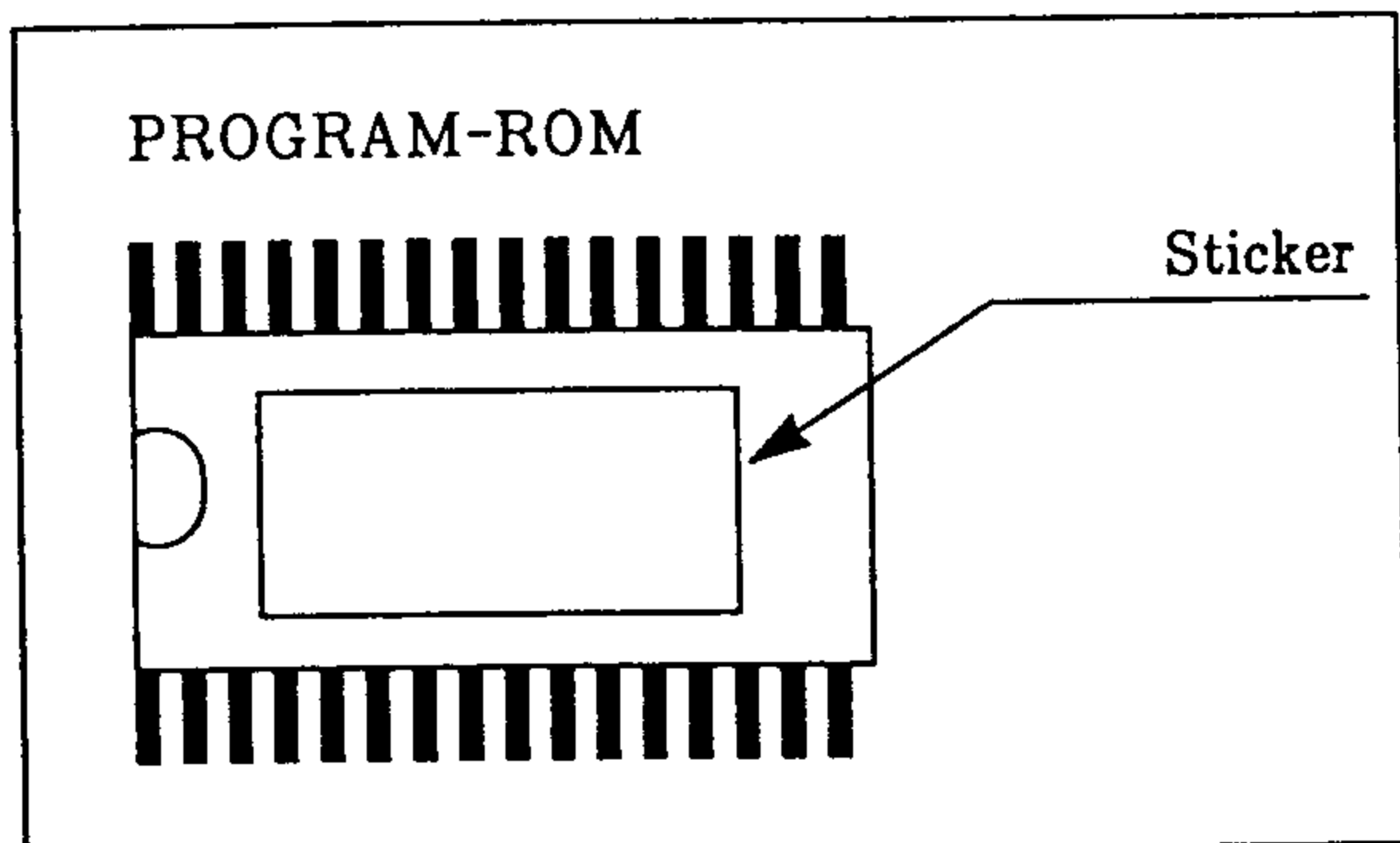

• Sticker Indication: Indicate by four figure as follows.

Ex) b005, b006, b□07

ROM Name	Indication of digital board	ROM Type	Number of Pin
Extension Pattern ROM	U9 (Upward Socket)	27C256	28 Pin
Program ROM	U8 (Downward socket)	27C512	28 Pin

Kind of ROM and Installing Position

(2) Notes and Mounting Location in case of ROM Changing

◀Note▶

- 1) You must turn off the power and after the indication on the operation board screen disappeared, practice mounting or replacing the ROM.
- 2) If you mount the direction marking incorrectly, ROM might be damaged.
- 3) Must mount that location of pin meet with socket correctly.
- 4) When you remove the existing ROM, use the IC removing tool or a small (-) rule driver that the board should not be damaged.

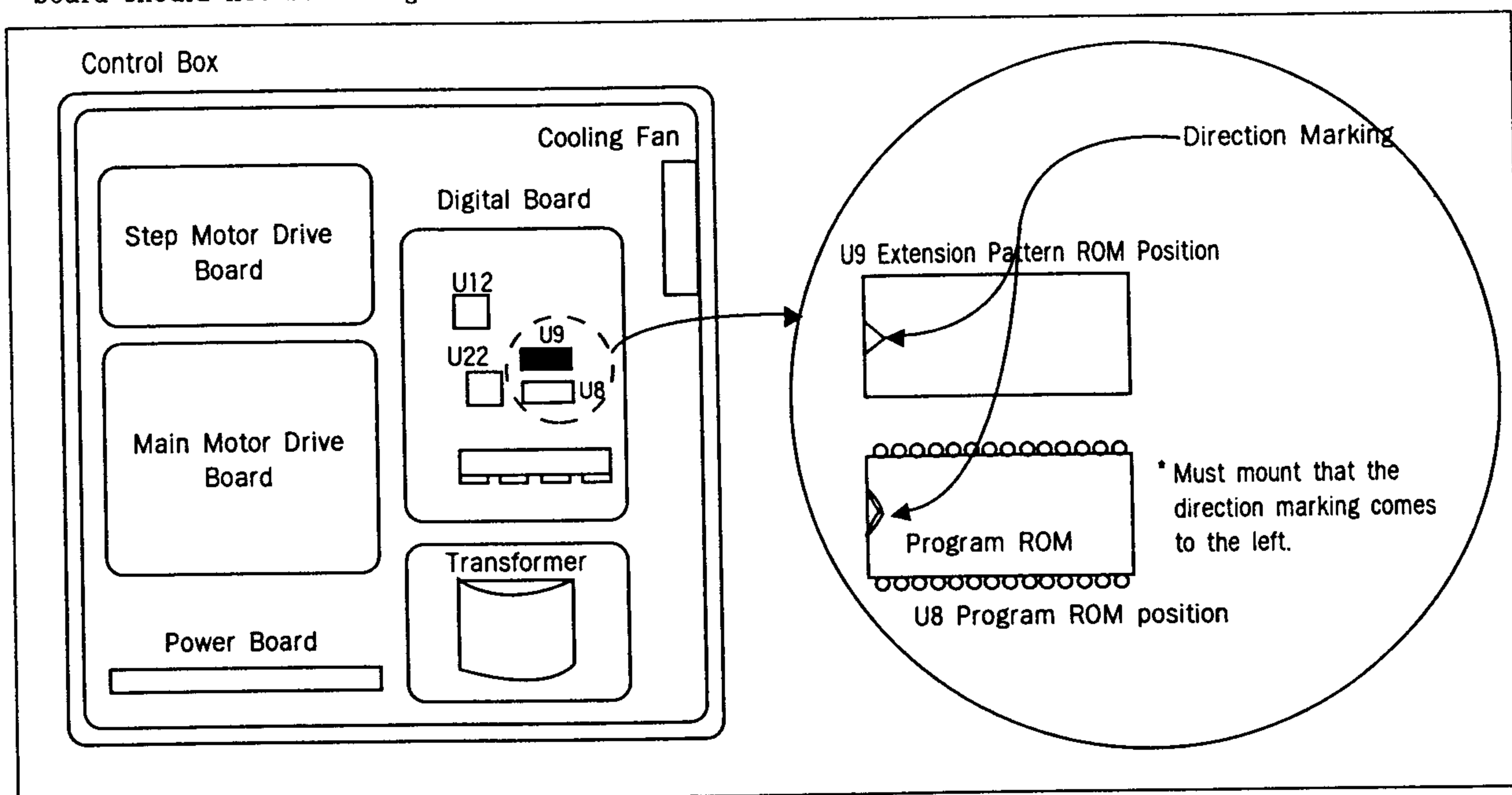

ROM Installing Position

(3) Using Method of Extension Pattern

① Mounting Method of Extension Pattern ROM

- 1) Separate the cover of Bartack control box
- 2) Mount the separately supplied extension design ROM at the location of "U9" on the digital board that the ROM pins enter into the socket correctly matched with the direction indicated at the board(that the direction marking comes to the left).
- 3) Press the extension design ROM tightly with fingers that it can enter into the socket

② Using Method of Extension Pattern

[Note]

- 1) If there is a pattern number set as "impossible to call" at the time of factory shipping, it can't use. Therefore, should use after set the pattern number to use as "possible to call".
- 2) Should use after confirming the pattern shape whether the needle and presser plate are not interfered.

B1201 Series

Setting Ex) Change the pattern number 33 and 34 into "possible to call".

A. After turning the power on pressing **Ready** and **Reset** key, press **A** key and press **+/FORWARD** key in order to indicate "A-03" on the screen.



A-03

B. Indicate the present set value by pressing **Ready** key.

Indication ① part: Pattern number ,

Indication ② part: 0: impossible to call 1: possible to call



01-1

①

②

C. Press **SELECT** key to make indication ① part to "01" - "33".



33-0

D. Press **+/FORWARD** key to make indication ② part to "0" - "1".



33-1

E. Press **SELECT** key to make indication ① part to "33" - "34".



34-0

F. Press **+/FORWARD** key to make indication ② part to "0" - "1".



34-1

G. Register by **Ready** key.



A-03

H. Turn off the power and then turn it on again.

B1202 Series

Setting Ex) Change the pattern number 34 and 35 into "possible to call".

A. After turning the power on pressing **Ready** and **Reset** key, press **A** key and press **+ / FORWARD** key in order to indicate "A-03" on the screen.



A - 03

B. Indicate the present set value by pressing **Ready** key.

Indication **ⓐ** part: Pattern number ,

Indication **ⓑ** part: 0: impossible to call 1: possible to call



01 - 1

ⓐ

ⓑ

C. Press **SELECT** key to make indication **ⓐ** part to "01" → "34".



34 - 0

D. Press **+ / FORWARD** key to make indication **ⓑ** part to "0" → "1".



34 - 1

E. Press **SELECT** key to make indication **ⓐ** part to "34" → "35".



35 - 0

F. Press **+ / FORWARD** key to make indication **ⓑ** part to "0" → "1".



35 - 1

G. Register by **Ready** key.



A - 03

H. Turn off the power and then turn it on again.

5. Breakdown and Trouble Shooting (Electronical Parts)

No.	Condition of Breakdown	Cause of Breakdown(1)	Cause of Breakdown(2)	Troubleshooting	
1.	No indication operating plate.	1) No power is supplied.	A) Cable No. 17 is disconnected. (Main circuit Board)	Insert the Cable.	
			B) Cable No. 19 is disconnected. (Main Circuit Board)		
			C) Cable No.15 is disconnected. (Drive Circuit Board)		
			D) F6 Fuse is cut. (Main Circuit Board)		After removing the cause of fuse cut, exchange the fuse (15A).
			E) F1 Fuse is cut. (Drive Circuit Board)		
			C) Cable No.1 is omitted. (Digital Circuit Board)		Insert the cable.
2.	All keys in operating plate do not work.	1) Switch is not connected between operating plate and membrane switch. 3) Circuit Board is out of order.	A) Switch cable inside of operating plate is disconnected.	Insert the cable of membrane switch again.	
				Exchange them in the order of drive circuit board and operating plate.	
3.	Movement is not available with READY key.	1) Power is not supplied into step motor drive plate. 2) Drive board is not connected to step motor. 3) Drive signal of step motor is not transmitted. (Digital circuit board→ Drive board) 4) Circuit board is out of order.	A) Cable No. 20 is omitted.	Insert th cable.	
			B) F1 Fuse is cut. (Main Circuit Board)	After removing the cause of fuse cut, exchange the fuse.	
			C) F2 Fuse is cut. (Main Circuit Board)		
			D) Cable No. 12 is disconnected.	Insert the cable.	
			E) Cable No. 13 is disconnected.		
			F) Cable No. 14 is disconnected.	Exchange them in the order of drive circuit board and digital circuit board.	
4.	If you press READY key, the machine exceeds feed limit.	1) Sensor signal is not transmitted 2) Circuit board is out of order.	A) Cable No. 4 is disconnected.	Insert the cable.	
			B) Sensor is out of order.	Exchange the sensor.	
				Exchange the digital circuit board.	

No.	Condition of Breakdown	Cause of Breakdown(1)	Cause of Breakdown(2)	Troubleshooting
5.	Feed plate does not ascend with READY key.	1) +33V is not supplied in digital circuit board. (In case of using electronic solenoid)	A) Cable No.18 is disconnected. (Main circuit board)	Insert the cable.
			B) F5 fuse is out. (Main circuit board)	After removing the cause of fuse cut, exchange the fuse.
		2) +24V is not supplied in IO circuit board. (In case of pneumatic type)	C) Cable No.18 is disconnected. (Main circuit board)	Insert the cable.
		3) Air pressure is not entered. (In case of pneumatic type)	D) F4 fuse is out. (Main circuit board)	After removing the cause of fuse cut, exchange the fuse.
		4) Solenoid cut		Insert the cable.
		5) Pneumatic switch and pneumatic cylinder are out of order. (In case of pneumatic type)		After measuring and confirming with tester, exchange solenoid.
		6) Circuit board is out of order.		Exchange the pneumatic switch and pneumatic cylinder.
6.	If you step on pedal for start sewing, the machine turns at one spot.	1) Signal for synchronizer is not available.	A) Cable No. 5 is disconnected.	Exchange the digital circuit board.
		2) Synchronizer is out of order.		Insert the cable.
		3) Circuit board is out of order.		Exchange the synchronizer.
7.	Sewing machine does not run even with pedalling.	1) Belt is disconnected.		Exchange them in the order of digital circuit board and drive circuit board.
		2) Drive circuit board is not connected to servo motor.	A) Cable No. 11 is disconnected. (Error occurs in No. 129.)	Insert the belt.
		3) Main motor circuit board is not connected to encoder.	B) Cable No. 6 is disconnected. (Error occurs in No. 128)	Insert the cable.
		4) Digital circuit board is not connected to pedal switch.	c) Cable No. 3 is disconnected.	
		5) Circuit board is out of order.		Exchange the encoder.
		6) Circuit board is out of order.		Exchange the pedal switch.
		7) Circuit board is out of order.		Exchange them in the order of drive circuit board and digital circuit board.

No.	Condition of Breakdown	Cause of Breakdown	Cause of Breakdown(2)	Troubleshooting
8.	Cooling fan does not run.	1) Power is not supplied to cooling fan. 2) Cooling fan is out of order. 3) Circuit board is out of order.	A) F3 fuse is cut. (Main circuit board)	After removing the cause of fuse cut, exchange the fuse. Exchange the cooling fan. Exchange the circuit board.
9.	If you step on pedal for start sewing, the machine turns at one spot.	1) Digital circuit board is not connected to drive circuit board. 2) Circuit board is out of order.	A) Cable No. 16 is disconnected.	Insert the cable. Exchange them in the order of digital circuit board and drive circuit board.
10.	OTHERS	1) Keys does not operate partly. 2) Circuit board is out of order.	A) Sewing machine is in the sewing available state.	Get out of the sewing available state by pressing READY key. Feeding error : Exchange them in the order of drive circuit board, main circuit board and digital circuit board. Other errors except feeding : Exchange the digital circuit board.

6

Error List

Use	Indication	Description	Occurrence of noise
1	Er01	Pattern calling is not available	x
2	Er02	Error in enlargement/Reduction	x
3	Er03	Error in needle bar position	x
4	Er04	Error in feed limit	x
5	Er05	Error in clamp position	x
6	Er06	When the origin movement is not available within the expected Time	x
7	Er07	In case of air pressure specifications (HA Type), if the air pressure is less than the regulated value	x
8	Er8	Error in ROM version according to new digital board	O
9	61	Error in synchronizer connection	O
10	128	Error in encoder connection	O
11	129	Overload in main motor	O
12	130	Error in synchronizer signal	O
13	EEPr	Error in EEPROM	O
14	1000~9999 CE17,LC18 BC20,AC19	Communication error in CPU circuit board	O

※ In the item of Occurrence of noise → O : Occurrence of buzzer, X : No Buzzer

Electronic Circuit Diagram

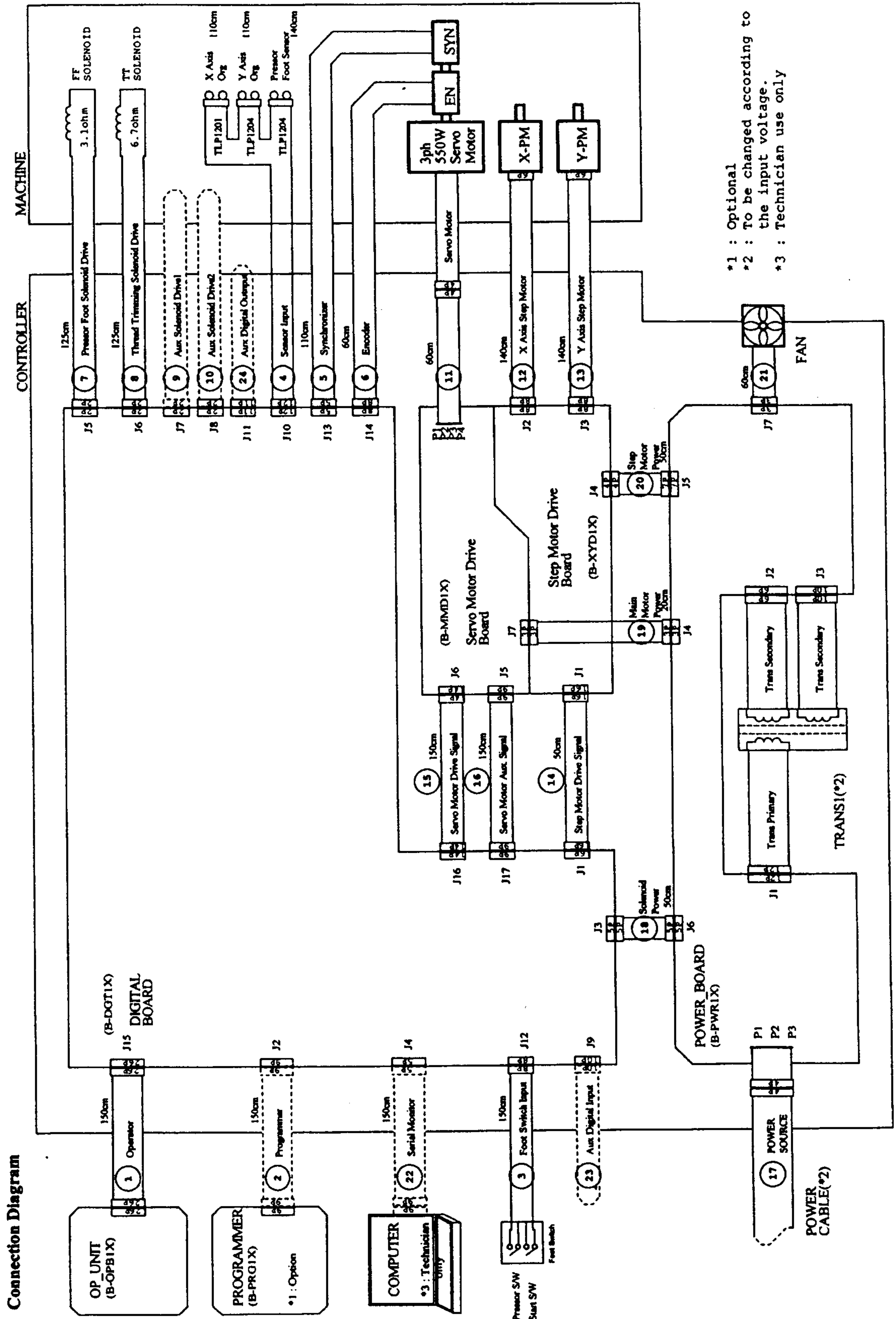

* Input voltage type POWER DIAGRAM

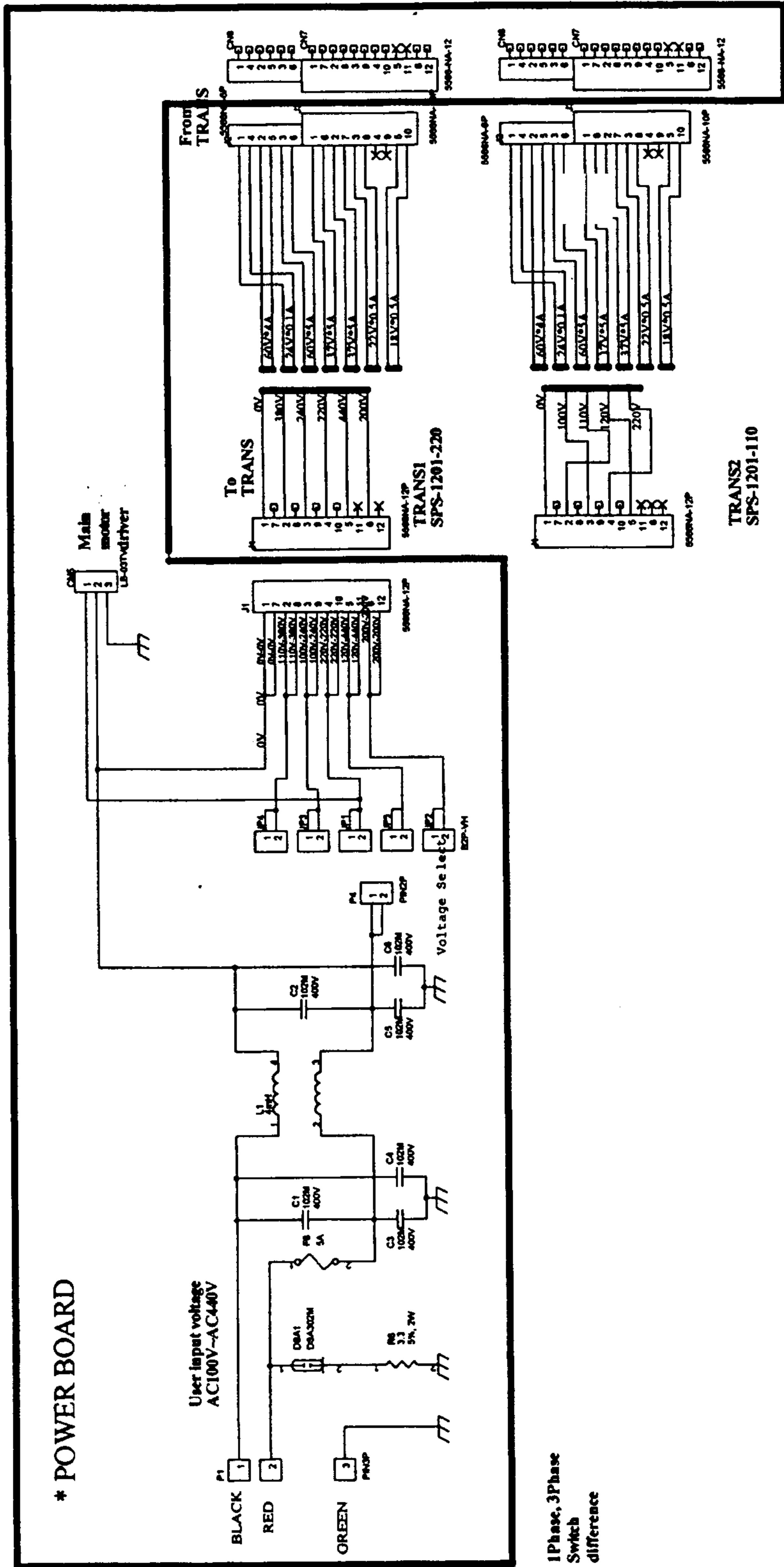

*** BARTACK 1201 SERIES
BLOCK DIAGRAM**

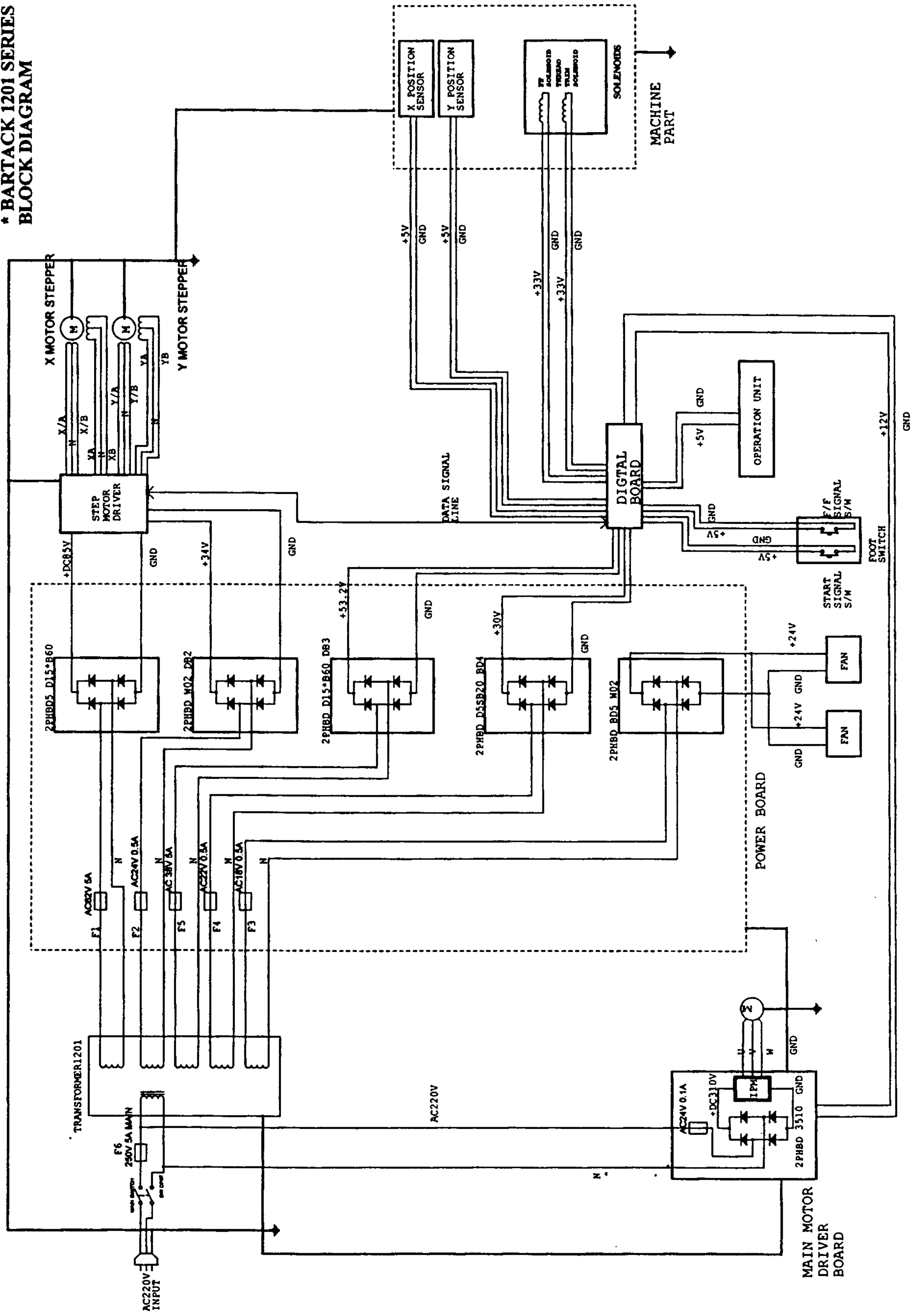

8

How Select the Sewing Pattern List and the Sewing Lange

1) B1201 Series

Application	No.	Pattern	Stitch Number	Range of Sewing	
				X(mm)	Y(mm)
For Heavy and General Materials	1		28	10	2
	2			16	2.5
	3		36	10	2
	4			16	2.5
	5		42	10	2
	6			16	2
	7			16	2.5
	8		24	3	
	9		56	24	3
	10		64	24	3
For Thin Materials	11		21	6	2.5
	12		28	6	2.5
	13		36	6	2.5
Knit	14		14	8	2
	15		21	8	2
	16		28	8	2
Straight Line	17		21	10	0

Application	No.	Pattern	Stitch Number	Range of Sewing	
				X(mm)	Y(mm)
Straight Line	18		28	10	0
	19			25	0
	20		36	25	0
	21		41	25	0
	22		44	35	0
Half Moon	31		42	11	7
	32		42	11	7

Vertical				
No.	23	24	25	26
Pattern				
Stitch Number	28	36	42	56
Range of Sewing	X (mm)	4	4	4
	Y (mm)	20	20	20

Linear Vertical				
No.	27	28	29	30
Pattern				
Stitch Number	18	21		28
Range of Sewing	X (mm)	0	0	0
	Y (mm)	20	10	20

Note) 1. It is available to provide 67 patterns except 32 patterns.

2. Select a presser foot and feeding plate suitable for the sewing method of pattern which you want to use.

2) B1202 Series

Pattern No.	Pattern	No of Threads	Range of Sewing		Pattern No.	Pattern	No of Threads	Range of Sewing	
			X (mm)	Y (mm)				X (mm)	Y (mm)
1		6-6	3.4	3.4	18		6	3.4	0
2		8-8	3.4	3.4	19		8	3.4	0
3		10-10	3.4	3.4	20		10	3.4	0
4		12-12	3.4	3.4	21		12	3.4	0
5*		6-6	3.4	3.4	22		16	3.4	0
6*		8-8	3.4	3.4	23		6	0	3.4
7*		10-10	3.4	3.4	24		10	0	3.4
8*		12-12	3.4	3.4	25		12	0	3.4
9		6-6	3.4	3.4	26		6-6	3.4	3.4
10		8-8	3.4	3.4	27		10-10	3.4	3.4
11		10-10	3.4	3.4	28*		6-6	3.4	3.4
12		6-6	3.4	3.4	29*		10-10	3.4	3.4
13		8-8	3.4	3.4	30		5-5-5	2.9	2.5
14		10-10	3.4	3.4	31		8-8-8	2.9	2.5
15*		6-6	3.4	3.4	32		5-5-5	2.9	2.5
16*		8-8	3.4	3.4	33		8-8-8	2.9	2.5
17*		10-10	3.4	3.4					

* The magnifying and reduction range (X and Y) of standard sewing shown above is 100%
66 patterns including 33 patterns can be additionally provided.

* In case of the pattern of "*" mark of Sewing Pattern No., a thread is trimmed after finish of first sewing to remove a line through sewing patterns. In case of SPS/A(or SPS/B)B1202-01 and 02, press the pedal once more after finish of first sewing, or continuously press and release the pedal until second sewing begins. In case of SPS/A(or SPS/B)-B1202-03, just one time pressing of the pedal will do.

A. If the central distance between use buttonholes does not conform for the standard sewing range of Sewing Pattern No., magnify or reduce the sewing range to adjust it.

B. After the Sewing Pattern Number and the sewing range (X, Y) are changed, don't forget to check if the needlepoint conforms to the buttonhole with regard to [Checking Pattern Shape].

C. Rate of magnifying and reduction according to the sewing range















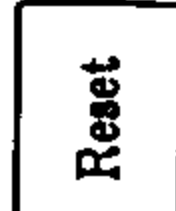

Sewing Area X,Y(mm)	2.4	2.6	2.8	3.0	3.2	3.4	3.6	4.0	4.3	4.5	4.7	5.2	5.6	6.0	6.2	6.4
Expansion & Reduction (%)	71	76	82	88	94	100	106	118	126	132	138	153	165	176	182	188

9. BASIC MANUAL

SPS/A(or SPS/B) -B Series

- 1 General Sewing: Sew by setting the sewing pattern, extension and reduction rate and sewing speed.
- 2 Use of Using Program: Conveniently call the sewing pattern that you frequent use.
- 3 Use of combined function: Sew by combining the sewing pattern in the order that you want.
- 4 Sewing Pattern Confirming

Reference: Turn the power on while pressing the switch.

- 1. User Program Registration

- 2. Use of Combined Function
 +   
Select the group by pressing only one from the three.
- 3. Parameter
 + 
- 4. Parameter Initialization
 +   + 
- 5. Machine Test
 +  + 
- 6. Inertia Tuning
 + 

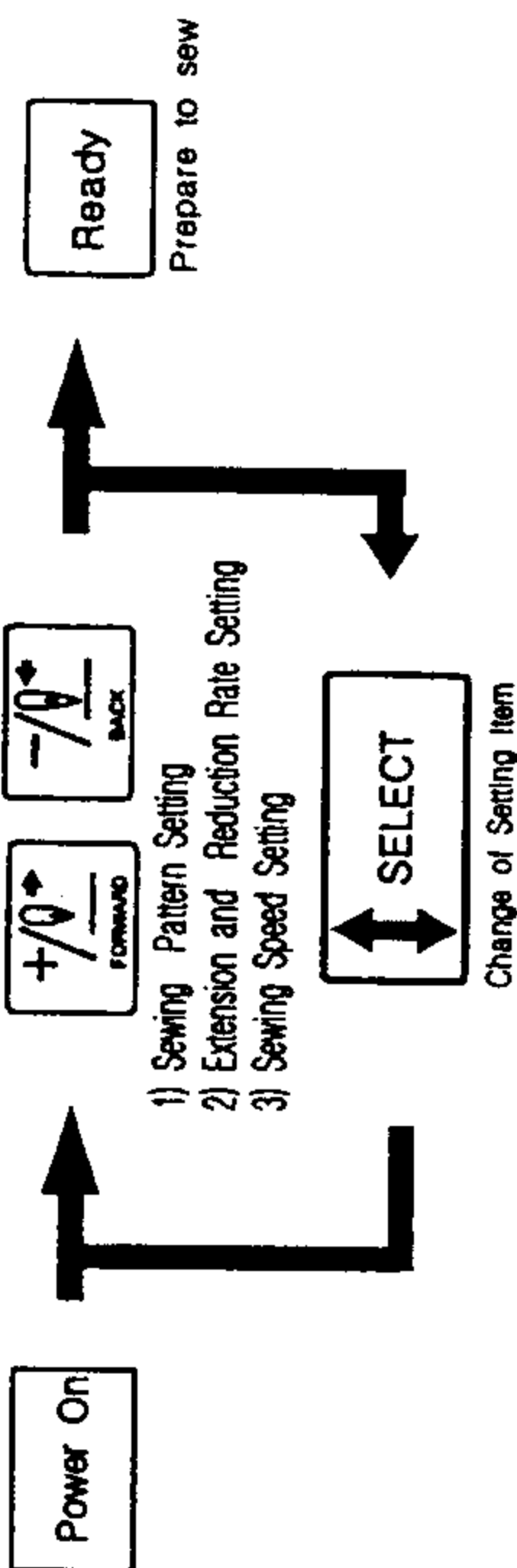
1 General Sewing: Sew by setting the sewing pattern, extension and reduction rate and sewing speed.

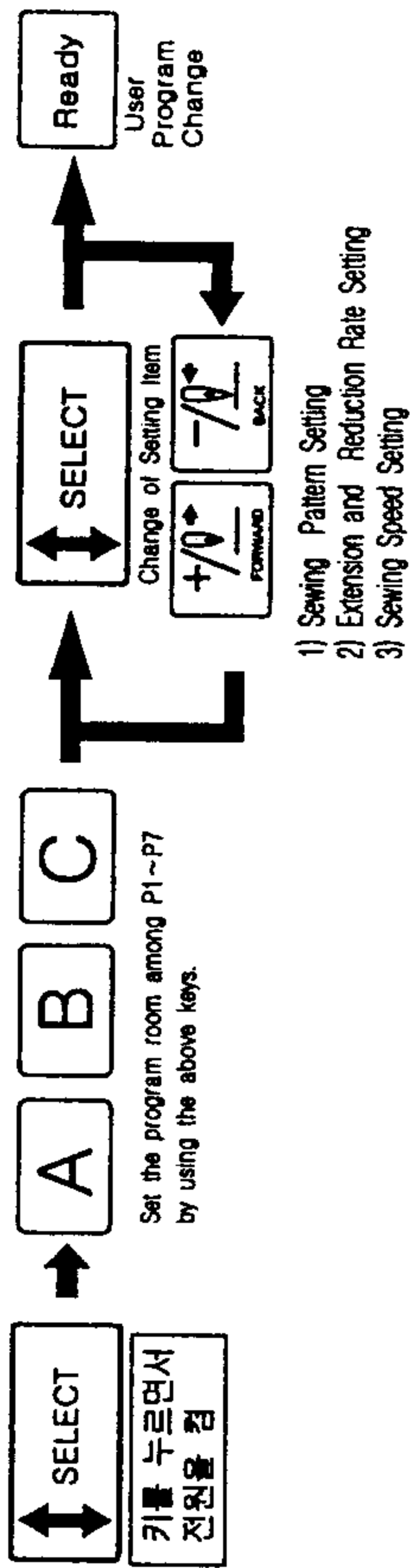

2 Use of Using Program: Conveniently call the sewing pattern that you frequent use.



3 Use of combined function: Sew by combining the sewing pattern in the order that you want.

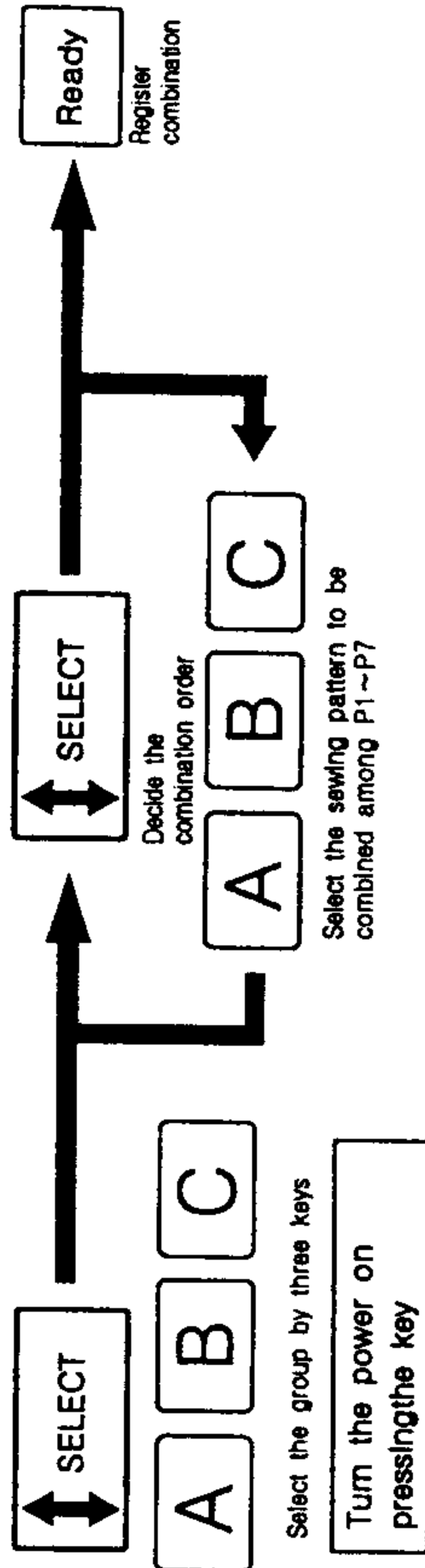

4. Sewing Pattern Confirming: Confirm whether the sewing pattern and parameter are interfered.

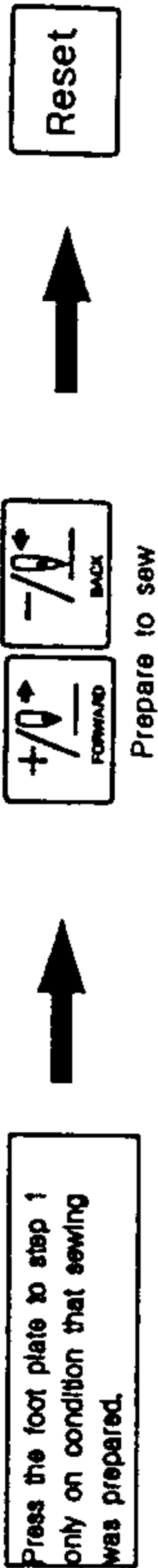

PFAFF

PFAFF Industrie Maschinen AG

Postfach 3020
D-67653 Kaiserslautern

Königstr. 154
D-67655 Kaiserslautern

Telefon: (0631) 200-0
Telefax: (0631) 17202
E-Mail: info@pfaff-industrial.com

Gedruckt in der BRD
Printed in Germany
Imprimé en R.F.A.
Impreso en la R.F.A.
Отпечатано в ФРГ