

PFAFF[®] **5642**

Service Manual

Contents

	Page
Notes on safety	1
The most important adjustment data in brief	1-2
1 Preliminary adjustment of needle bar height	3
2 Looper drive eccentric	4
3 Feed lifting eccentric	6
3.1 On machines with 33 mm needle bar stroke	6
3.2 On machines with 36 mm needle bar stroke (model H)	7
4 Spreader drive eccentric	8
5 Feed driving eccentric and needle bar frame drive	9
5.1 On machines with 33 mm needle bar stroke	9
5.2 On machines with 36 mm needle bar stroke (model H)	10
6 Feed dog position	11
6.1 Crosswise to sewing direction	11
6.2 In sewing direction on machines with 33 mm needle bar stroke	12
6.3 In sewing direction on machines with 36 mm needle bar stroke (model H)	13
7 Feed dog height	14
8 Position of needle in needle hole	15
8.1 Crosswise to sewing direction	15
8.2 In sewing direction	16
9 Looper-to-needle clearance	17
9.1 In sewing direction	17
9.2 Crosswise to sewing direction	18
10 Needle bar height	19
11 Spreader position	20
11.1 In sewing direction	20
11.2 Crosswise to sewing direction and looper	21
12 Needle guard	22
13 Regulating the looper thread	23
14 Needle thread regulation and take-up lever guard	24
15 Stitch length limitation	25
16 Fabric clearance	26
17 Knee lever rest position and stroke limitation	28
18 Tension release	29

Notes on safety

The machine must only be used for the purpose it was designed for.
When converting it to another version, all valid safety regulations have to be considered.
Adjustment and repair work must only be carried out by persons instructed accordingly.
Apart from permissible deviations according to DIN 57 105 and VDE 0105, work on live parts is not permitted.

Please note:

This service manual applies for the single-needle- as well as for the multi-needle version.
Divergencies in the illustrations have no bearing on the adjustments.

Tools, gauges and other equipment needed for adjustment

Set of screwdrivers with blades from 2 to 10 mm
Set of allen keys from 1.5 to 6 mm
Adjustment pin, 3 mm dia. (flattened to 2.3 mm at one end), part No. 61-111 643-55
Positioning pin, 5 mm dia., part No. 13-030 341-05
Positioning pin, 6 mm, with 3 mm end dia., part No. 61-111 643-53
C-clamp, part No. 08-880 137-00
Adjusting gauge (5 and 7 mm), part No. 61-111 643-54
Metal rule, part No. 08-880 218-00
Packet of system 5640 needles
Sewing thread and testing fabric

The most important adjustment data in brief

Step-by-step
adjustment
in section

- 1 Position of needle in needle hole
at b.d.c. of needle bar

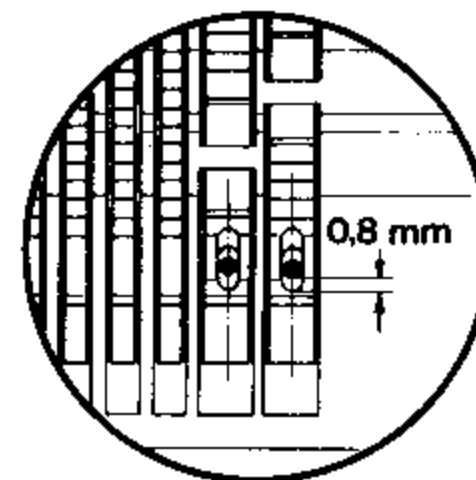

8

- 2 Feed dog height at
b.d.c. of needle bar

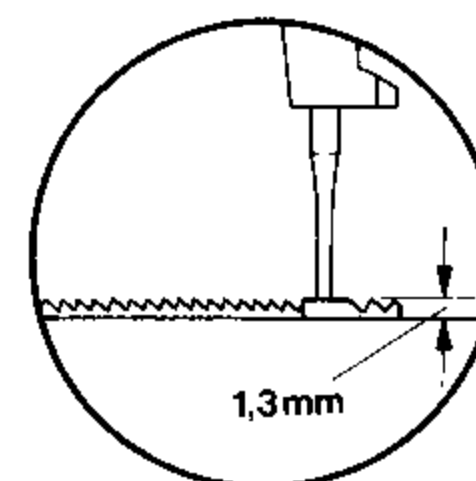

7

- 3 Feed driving motion
at needle rise position (5 mm past b.d.c. of needle bar) upon actuation
of the stitch condensation lever rest position of feed dog

5

- 4 Feed dog lifting motion
at b.d.c. of needle bar = highest position of feed dog

3

5 Looper drive eccentric
at b.d.c. of needle bar
for stitch lengths
over 4.5 mm

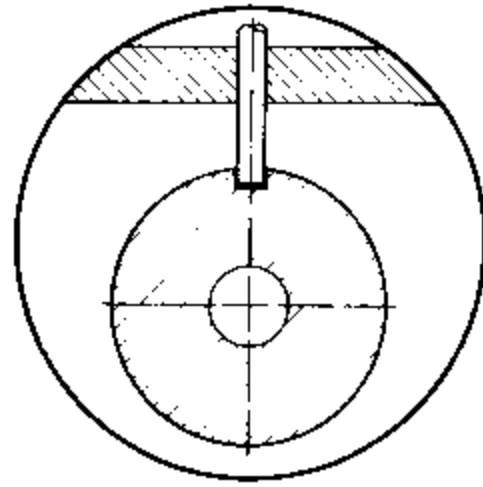

at b.d.c. of needle bar
for stitch lengths
up to 4.5 mm

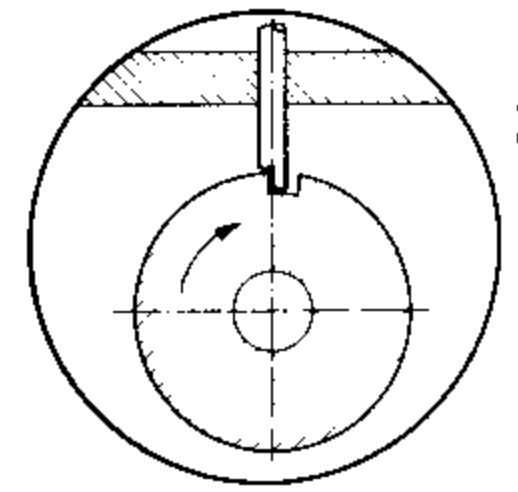

2

6 Needle rise 5 mm

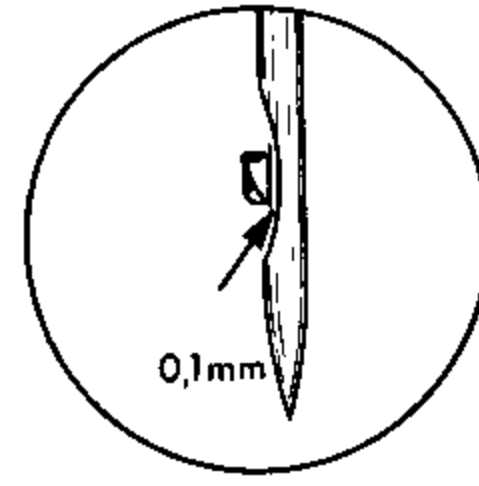
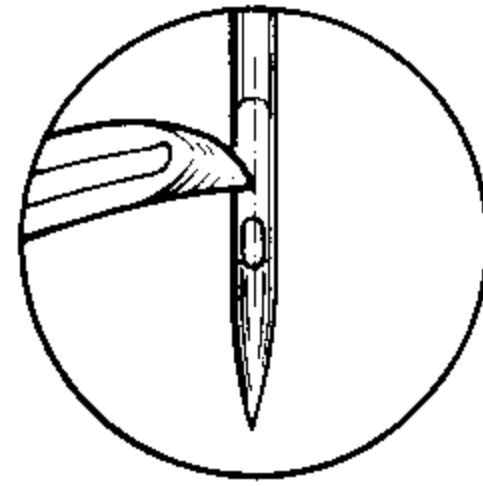

2

7 Looper-to-needle
clearance

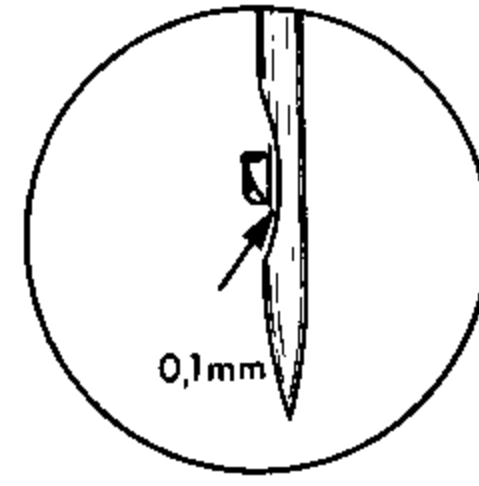
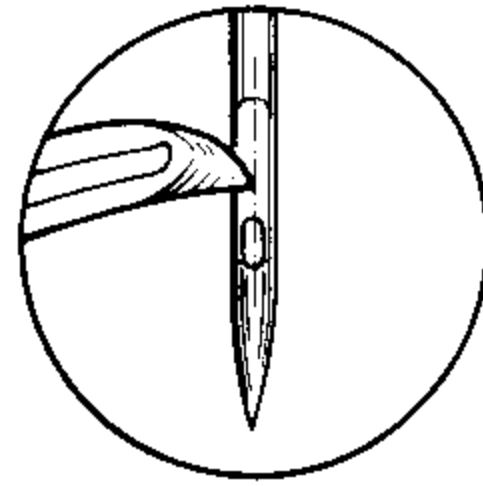

9

8 Needle guard

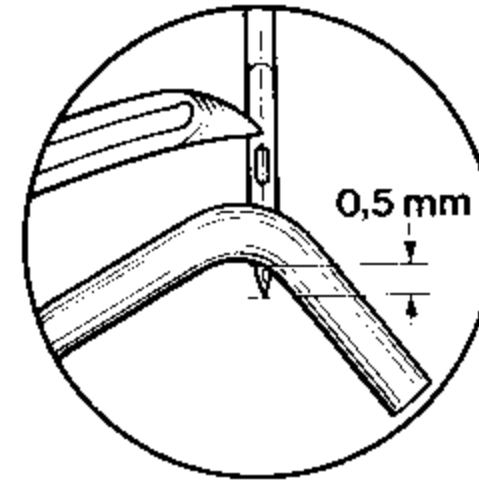
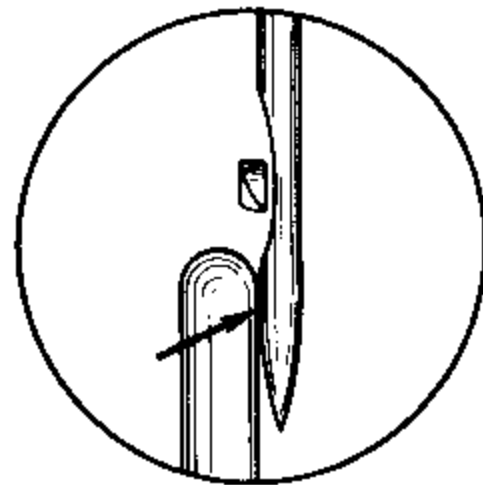

12

9 Needle height

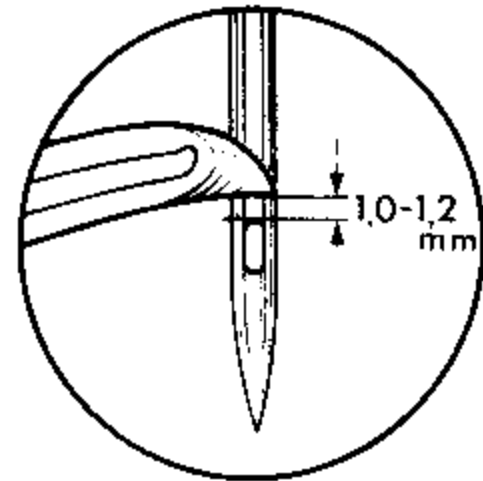

10

10 Spreader stroke
5.5 mm
4.5 mm for needle gauge 4.8 mm

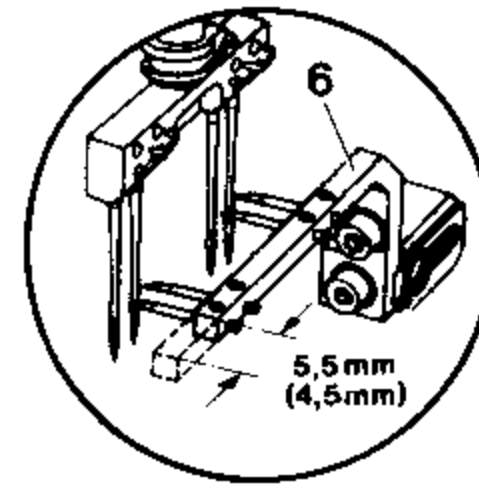

4

11 Spreader timing
at b.d.c. of needle bar

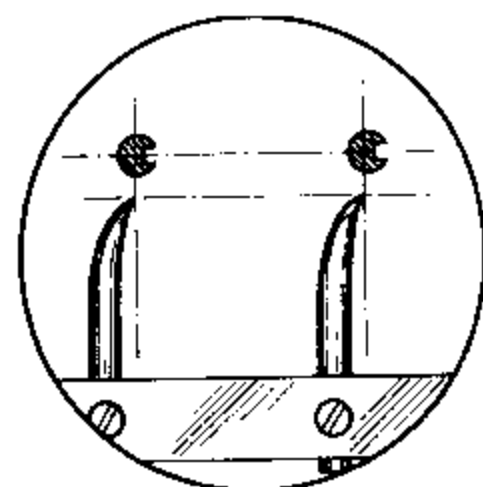

4

12 Spreader position
in sewing direction

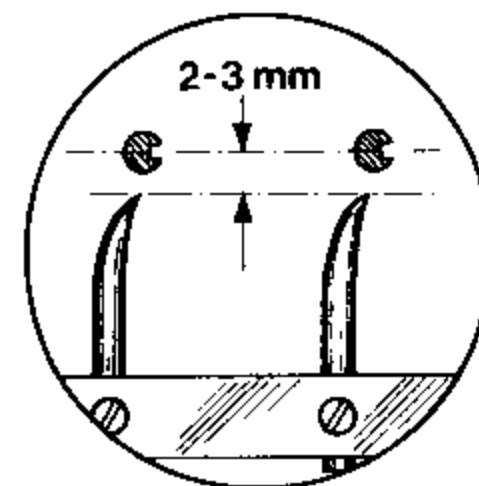
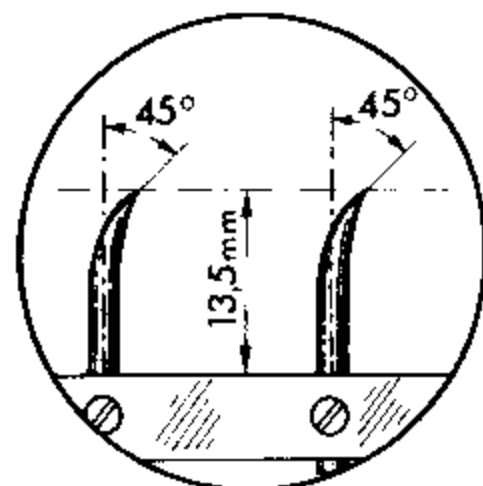

11

crosswise to sewing direction

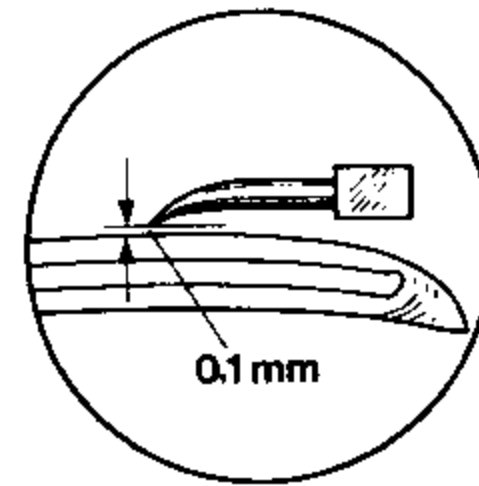
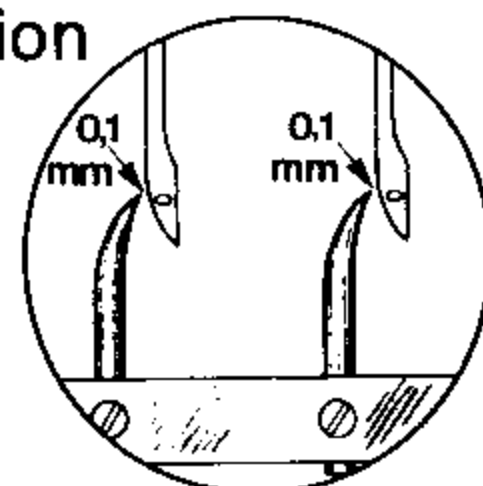

2

1 Preliminary adjustment of needle bar height

Setting:

With the needle bar at t.d.c., the clearance between needle point and needle plate must be **11 mm** or **13 mm**, depending on the needle bar stroke.
33 mm needle bar stroke = 11 mm
36 mm needle bar stroke = 13 mm

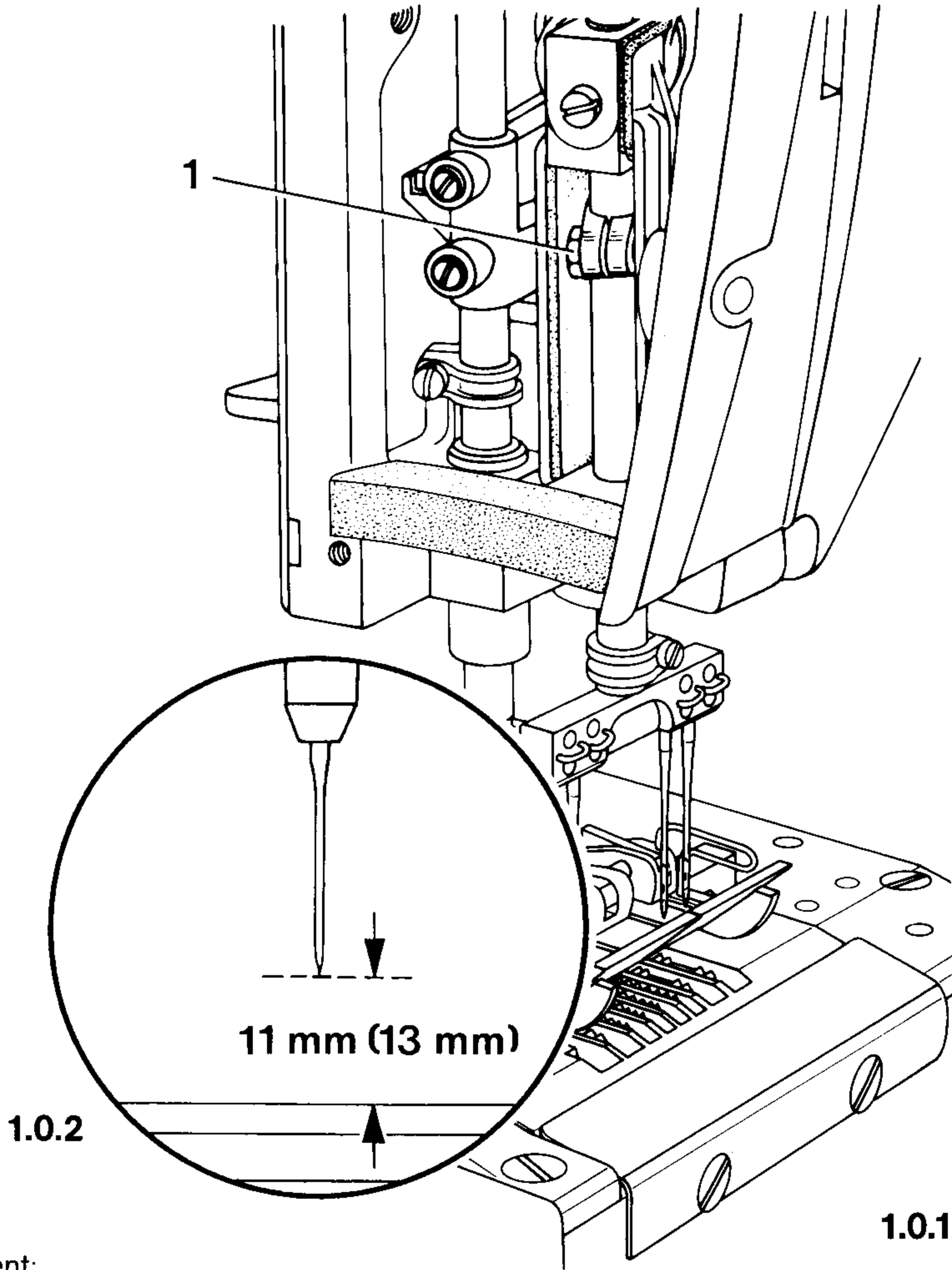

Adjustment:

- 1.1 Unscrew face plate.
- .2 Set needle bar at t.d.c.
- .3 Loosen screw 1.
- .4 **Reposition needle bar vertically until the clearance between needle point and needle plate is 11 mm or 13 mm (see "Setting").**
- .5 Tighten screw 1.

Setting:

For stitch lengths longer than 4.5 mm:

With the needle bar at b.d.c., the rounded end of the 3-mm-thick adjustment pin must enter groove 7 when the pin is inserted through hole 6 (see Fig. 2.0.4).

For stitch lengths up to 4.5 mm:

With the needle bar at b.d.c., the flattened end of the adjustment pin inserted through hole 6 must enter groove 7 in such a way that the flat section of the pin contacts the rear edge of the groove (see Fig. 2.0.3).

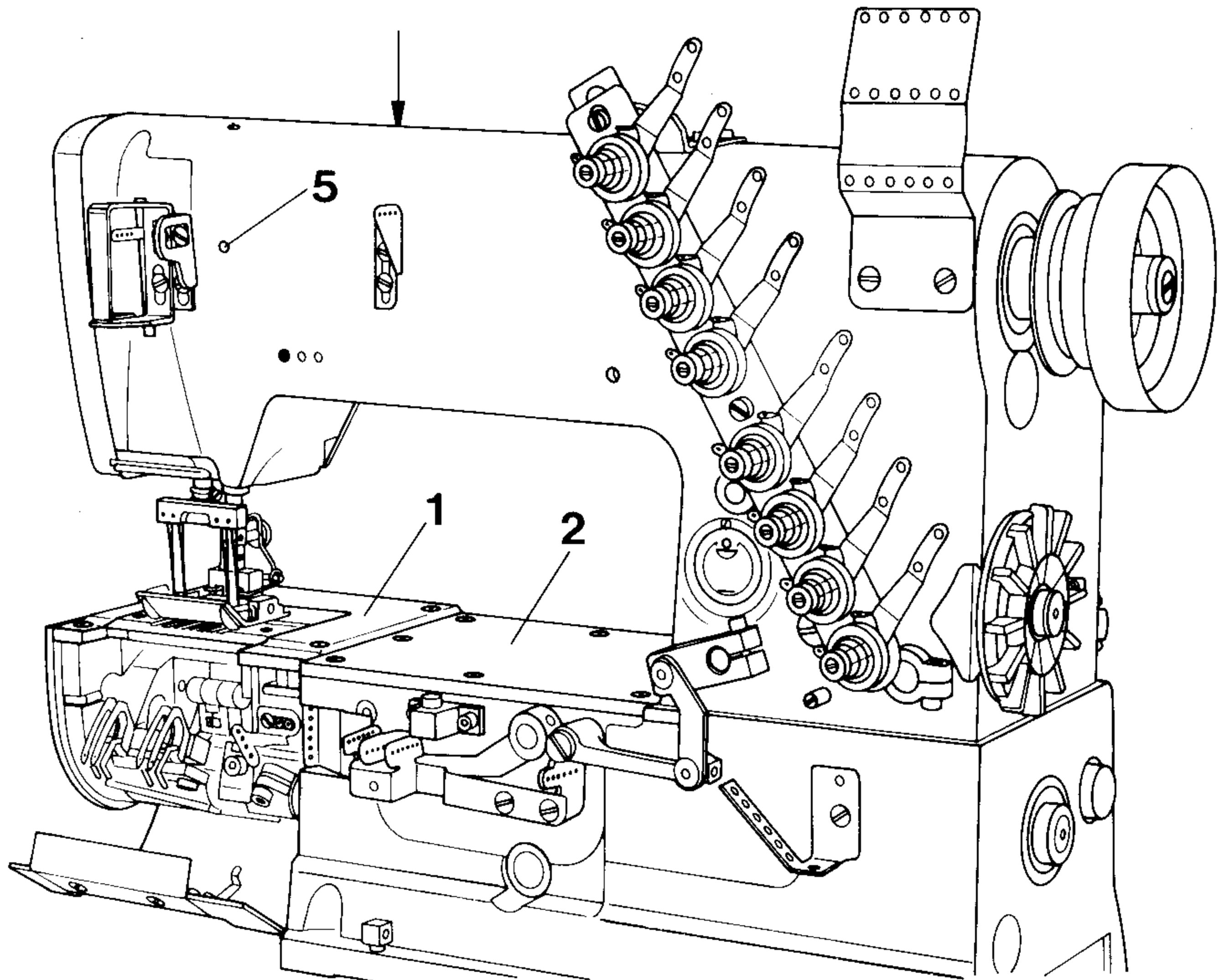

2.0.1

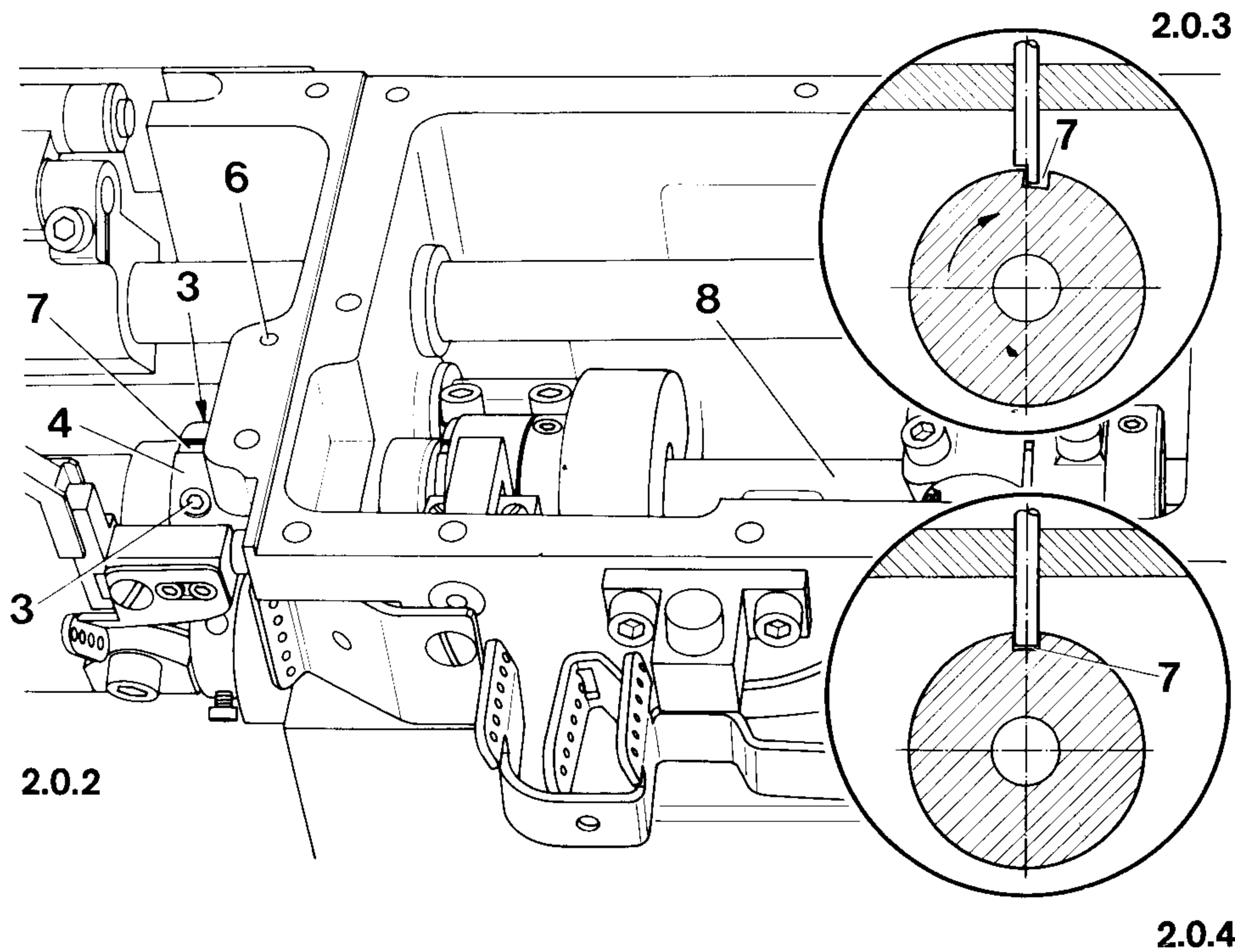

Adjustment:

- 2.1 Unscrew presser foot and cover plate 1.
- .2 Loosen screw 3 so that eccentric 4 can be turned against resistance.
- .3 Set needle bar at b.d.c. and insert the 5-mm adjustment pin in hole 5 (to block the machine).
- .4 **For stitch lengths longer than 4.5 mm**, turn eccentric 4 so that groove 7 is positioned vertically above looper drive shaft 8.
When using the 3-mm adjustment pin, turn eccentric 4 so that the rounded end of the pin inserted through hole 6 can enter groove 7.
- For stitch lengths up to 4.5 mm**, turn eccentric 4 so that the rear edge of groove 7 (as seen in the direction of rotation) is positioned vertically above looper drive shaft 8. When using the 3-mm adjustment pin, turn eccentric 4 so that the rear edge of groove 7 contacts the flat section of the pin.
- .5 Tighten screws 3 and remove the adjustment pins from holes 5 and 6.

3 Feed lifting eccentric

3.1 On machines with 33 mm needle bar stroke

Setting:

With the needle bar at b.d.c., groove 4 must be positioned vertically above looper drive shaft 5.

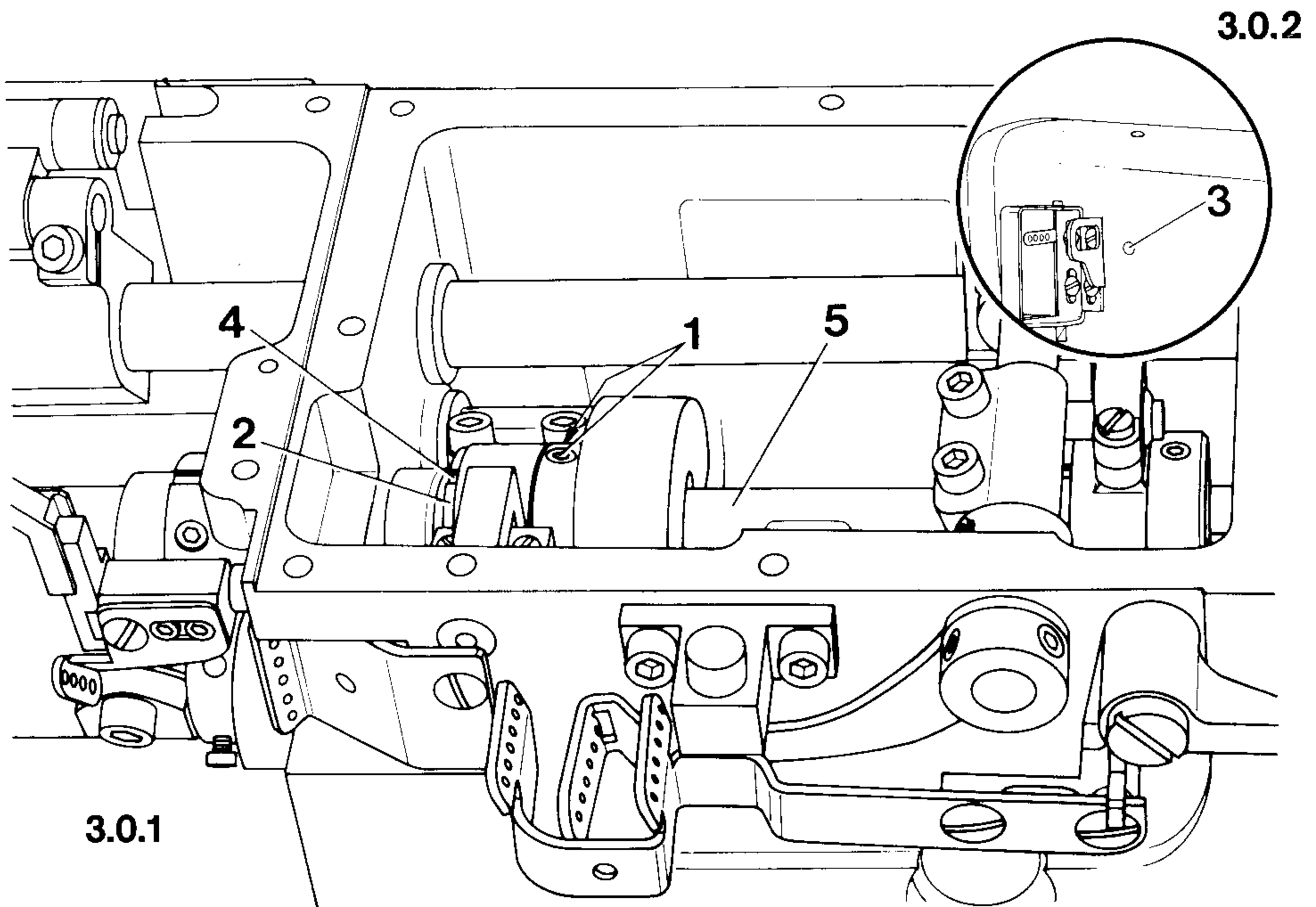

Adjustment:

- 3.1.1 Unscrew cover 2 (Fig. 2.0.1) and loosen screws 1 so that eccentric 2 can be turned against resistance.
- .2 Set needle bar at b.d.c. and insert the 5-mm adjustment pin in hole 3 (to block the machine).
- .3 **Turn eccentric 2 on the shaft so that groove 4 is positioned vertically above looper drive shaft 5.**
- .4 Tighten screws 1 and take the adjustment pin out of hole 3.
- .5 Check this adjustment (see "Setting").

3.2 On machines with 36 mm needle bar stroke (model H)

Setting:

With the needle bar at a position 0.9 mm before b.d.c., groove 4 must be positioned vertically above looper drive shaft 5.

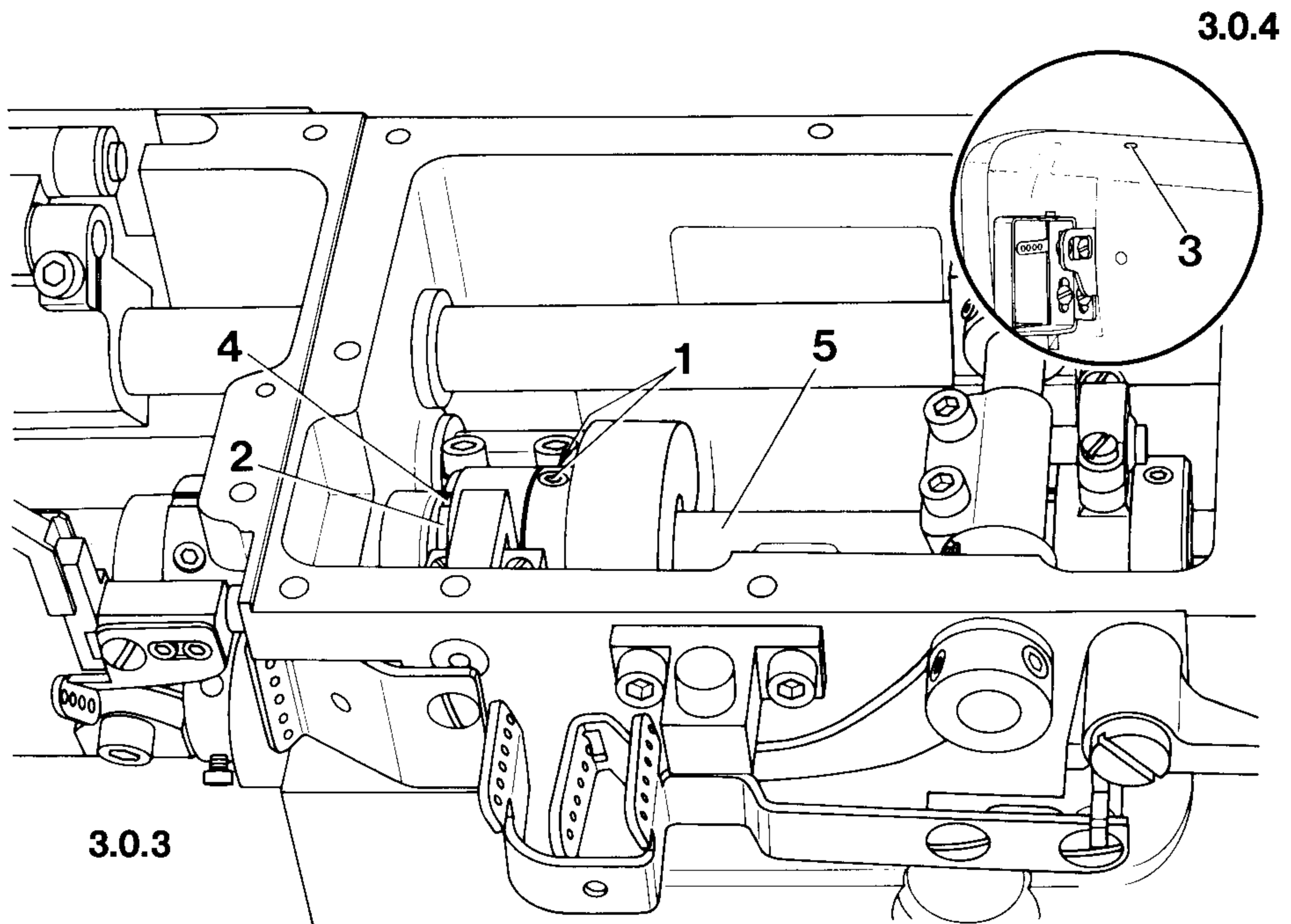

Adjustment:

- 3.2.1 Loosen screws 1 so that eccentric 2 can be turned against resistance.
- .2 Set needle bar at 0.9 mm before b.d.c. and insert the 5-mm adjustment pin in hole 3 (to block the machine).
- .3 **Turn eccentric 2 on the shaft so that groove 4 is positioned vertically above looper drive shaft 5.**
- .4 Tighten screws 1 and take the adjustment pin out of hole 3.
- .5 Check this adjustment (see "Setting").

4 Spreader drive eccentric

Setting:

With the needle bar at b.d.c., groove 4 of eccentric 2 must be positioned vertically above looper drive shaft 5. The stroke of spreader bracket 6 must be **5.5 mm**. On machines with 4.8 mm needle gauge, or needle gauge combinations in which the needle gauge of 4.8 mm is contained, this stroke must be **4.5 mm**.

4.0.2

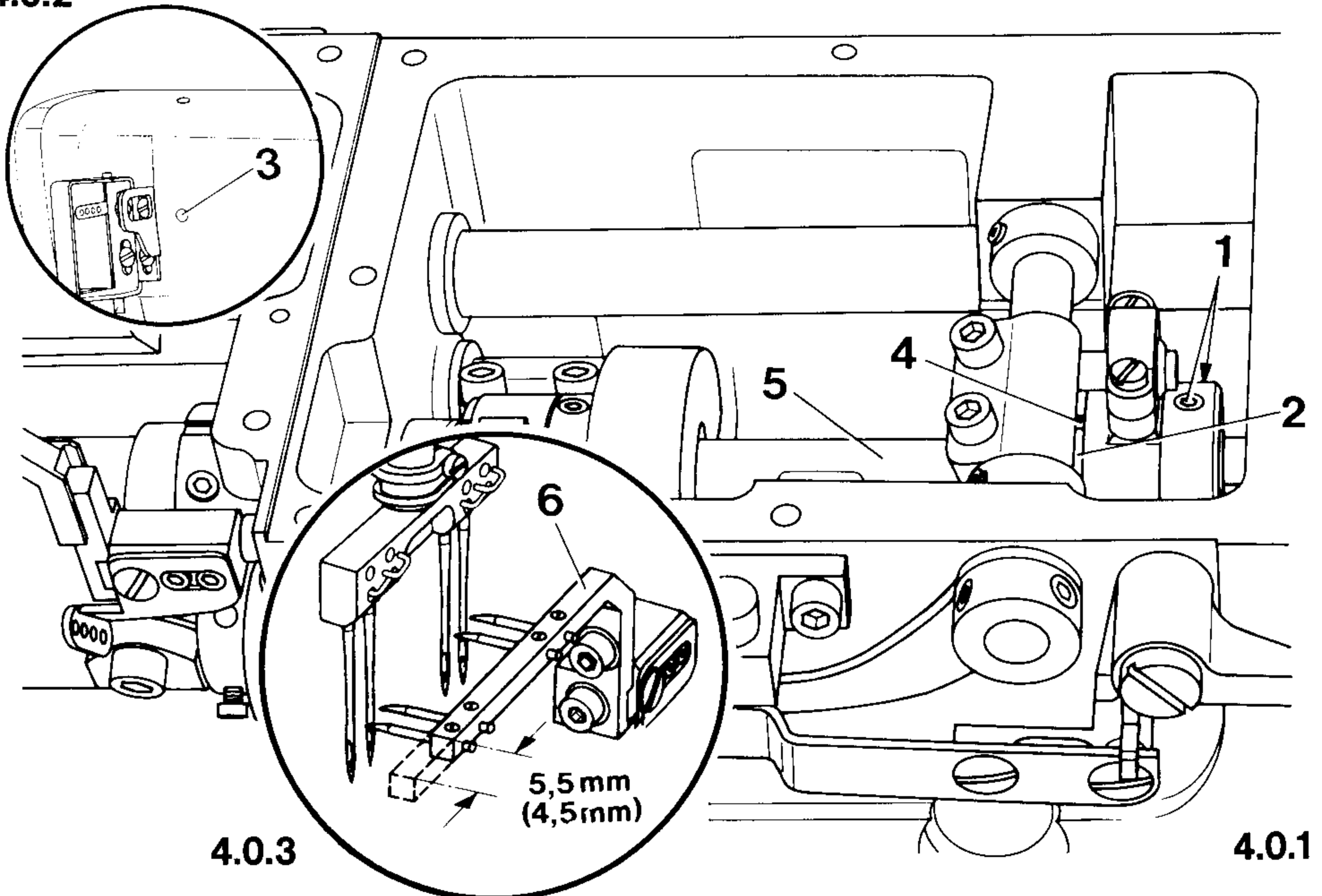

Adjustment:

- 4.1 Loosen screws 1 so that eccentric 2 can be turned against resistance.
- .2 Set needle bar at b.d.c. and insert the 5-mm adjustment pin in hole 3 (to block the machine).
- .3 **Turn eccentric 2 on the shaft so that groove 4 is positioned vertically above looper drive shaft 5.**
- .4 **Reposition eccentric 2 axially so that the stroke of spreader bracket 6 is 5.5 mm (4.5 mm) (see "Setting").**
- .5 Tighten screws 1 and take the adjustment pin out of hole 3.
- .6 Check this adjustment (see "Setting").
- .7 Fit the cover to the gear case.

5 Feed driving eccentric and needle bar frame drive

5.1 On machines with 33 mm needle bar stroke

Setting:

With the needle bar at b.d.c., groove 4 of feed driving eccentric 2 must be positioned exactly above shaft 5 (see Fig. 5.0.1). In this position, the imaginary center lines of crank 8 and connecting rod 7 must be parallel to each other (see Fig. 5.0.3).

5.0.2

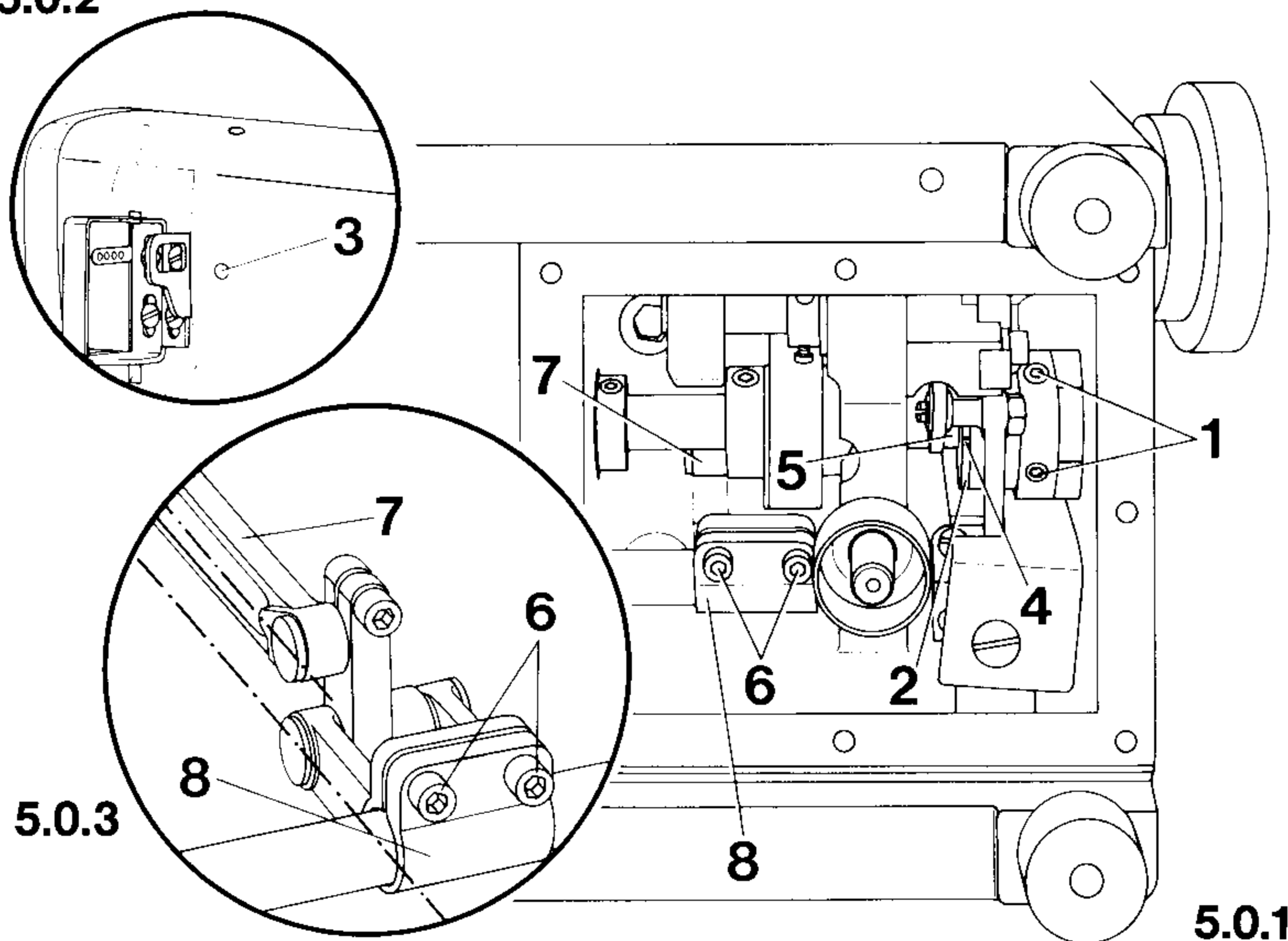

Adjustment:

- 5.1.1 Unscrew the gear cover at the underside of the machine stand.
- .2 Loosen screws 1 so that eccentric 2 can be turned against resistance.
- .3 Set needle bar at b.d.c. and insert the 5-mm adjustment pin in hole 3 (to block the machine).
- .4 **Turn feed driving eccentric 2 on its shaft so that groove 4 is positioned exactly above the center of shaft 5.**
- .5 Tighten screws 1.
- .6 Loosen screws 6 and, **making sure that connecting rod 7 does not contact the housing** (see arrow in Fig. 8.0.3), **turn drive crank 8 so that the imaginary center lines of drive crank 8 and connecting rod 7 are parallel to each other** (see Fig. 5.0.3).
- .7 Tighten screws 6 and take the adjustment pin out of hole 3.
- .8 Check this adjustment (see "Setting").
- .9 Replace gear cover.

5.2 On machines with 36 mm needle bar stroke (model H)

Setting:

At a needle bar position 0.9 mm before b.d.c., groove 4 must be positioned vertically above looper drive shaft 5 (see Fig. 5.0.4).

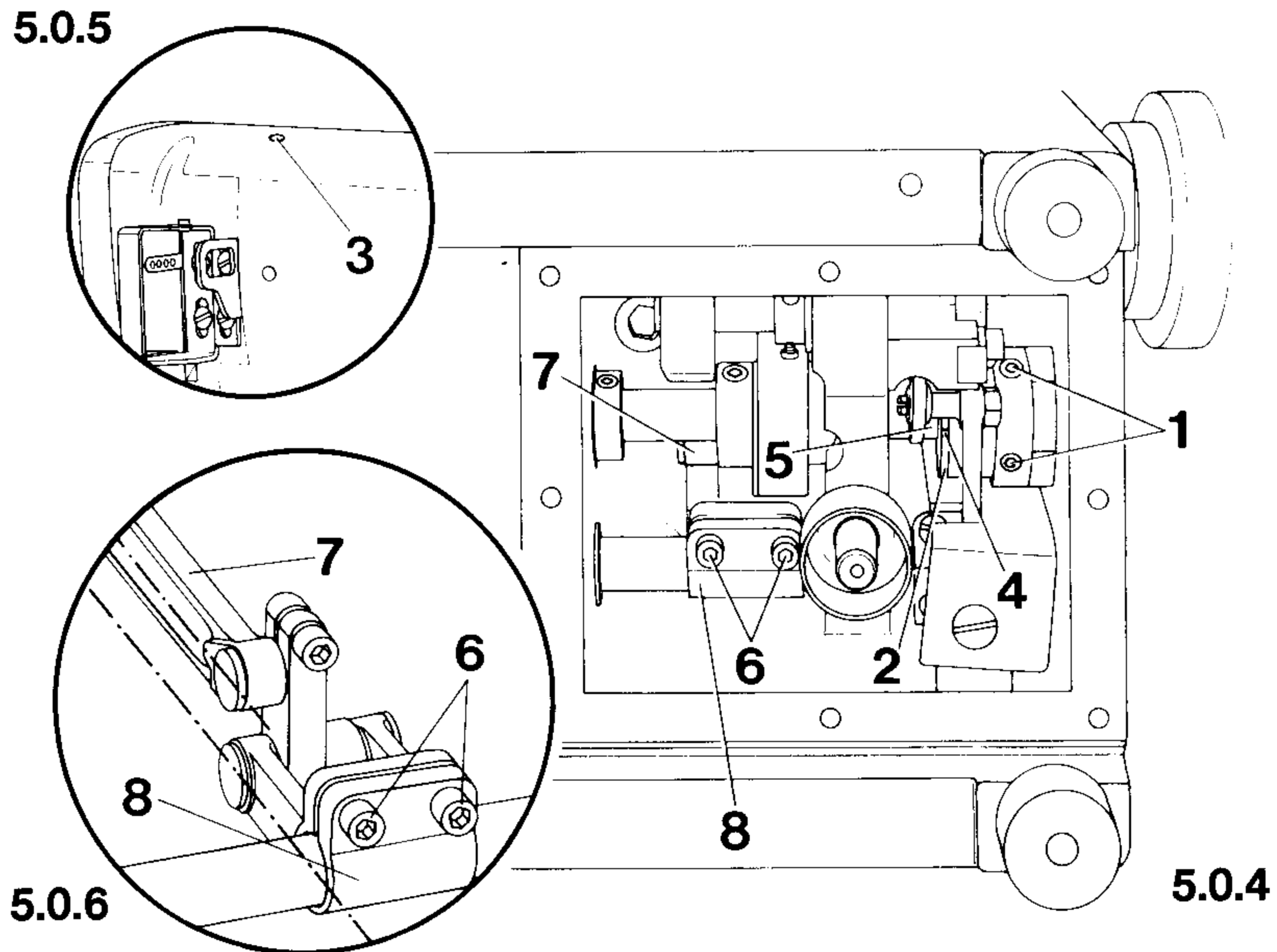

Adjustment:

- 5.2.1 Unscrew the gear cover at the underside of the machine stand.
- .2 Loosen screws 1 so that eccentric 2 can be turned against resistance.
- .3 Set needle bar at a position 0.9 mm before b.d.c. and insert the 5-mm adjustment pin in hole 3 (to block the machine).
- .4 **Turn feed driving eccentric 2 on its shaft so that groove 4 is positioned exactly above the center of shaft 5.**
- .5 Tighten screws 1.
- .6 Loosen screws 6 and, **making sure that connecting rod 7 does not contact the housing** (see arrow in Fig. 8.0.3), **turn drive crank 8 so that the imaginary center lines of drive crank 8 and connecting rod 7 are parallel to each other** (see Fig. 5.0.6).
- .7 Tighten screws 6 and take the adjustment pin out of hole 3.
- .8 Check this adjustment (see "Setting").
- .9 Replace lower gear cover.

6 Feed dog position

6.1 Crosswise to sewing direction

Setting:

The feed dog must be centered in the needle plate slots and move freely in them.

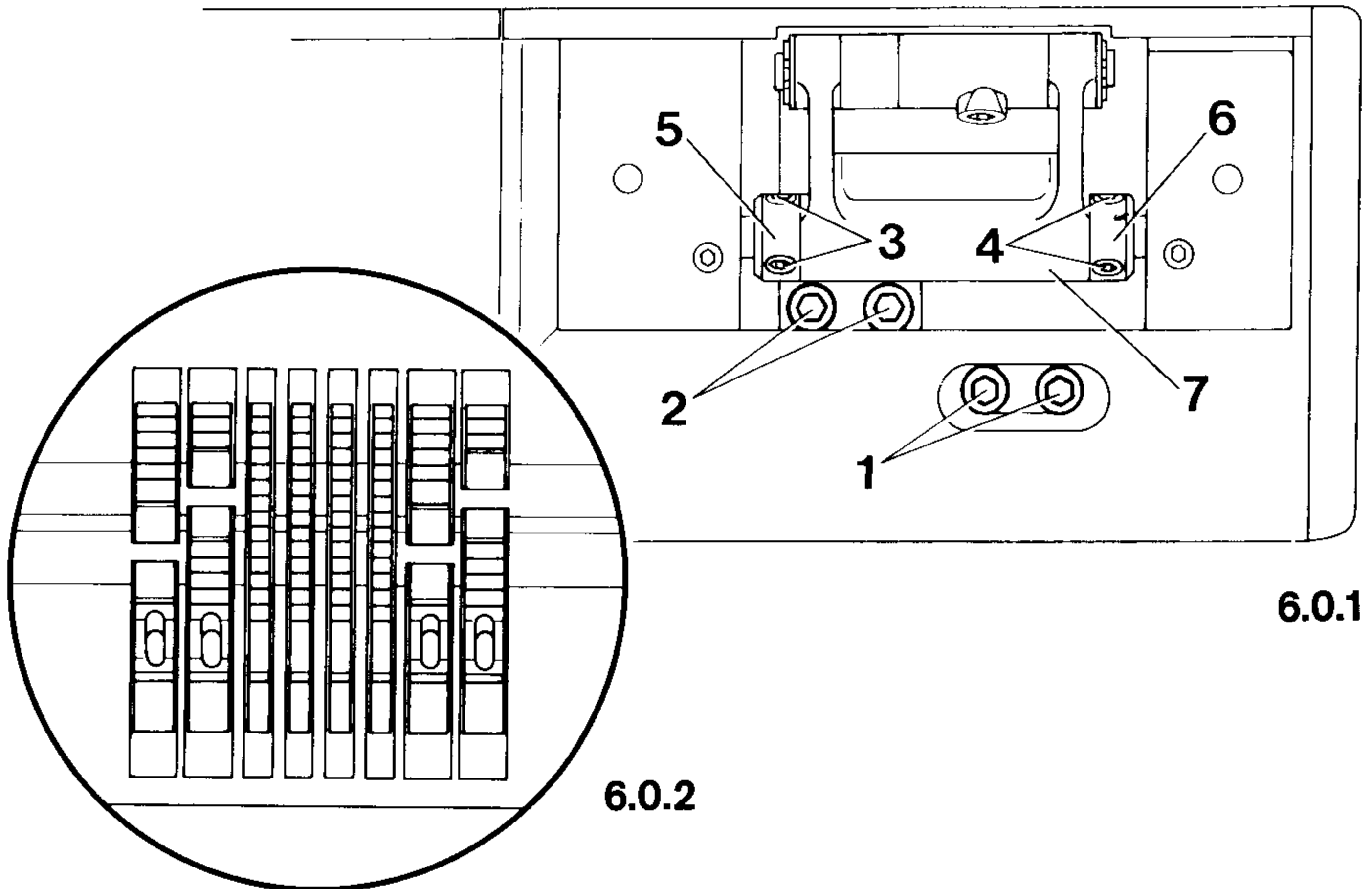

Adjustment:

- 6.1.1 Unscrew cover plate at the back of the arm-bed.
- .2 Loosen screws **1**, **2**, **3**, and **4**.
- .3 Set the maximum stitch length.
- .4 Fit cover plate together with needle plate.
- .5 **Position feed mechanism 7 so that the feed dog is laterally centered in the feed slots.**
- .6 Push fixing collars **5** and **6** up against feed mechanism **7** and tighten screws **3** and **4**.
- .7 Check this adjustment (see "Setting").

6.2 In sewing direction on machines with 33 mm needle bar stroke

Setting:

With the needle bar at b.d.c. and the maximum stitch length set, the 6-mm adjustment pin must fit into hole 4 with its 3-mm end.

6.0.5

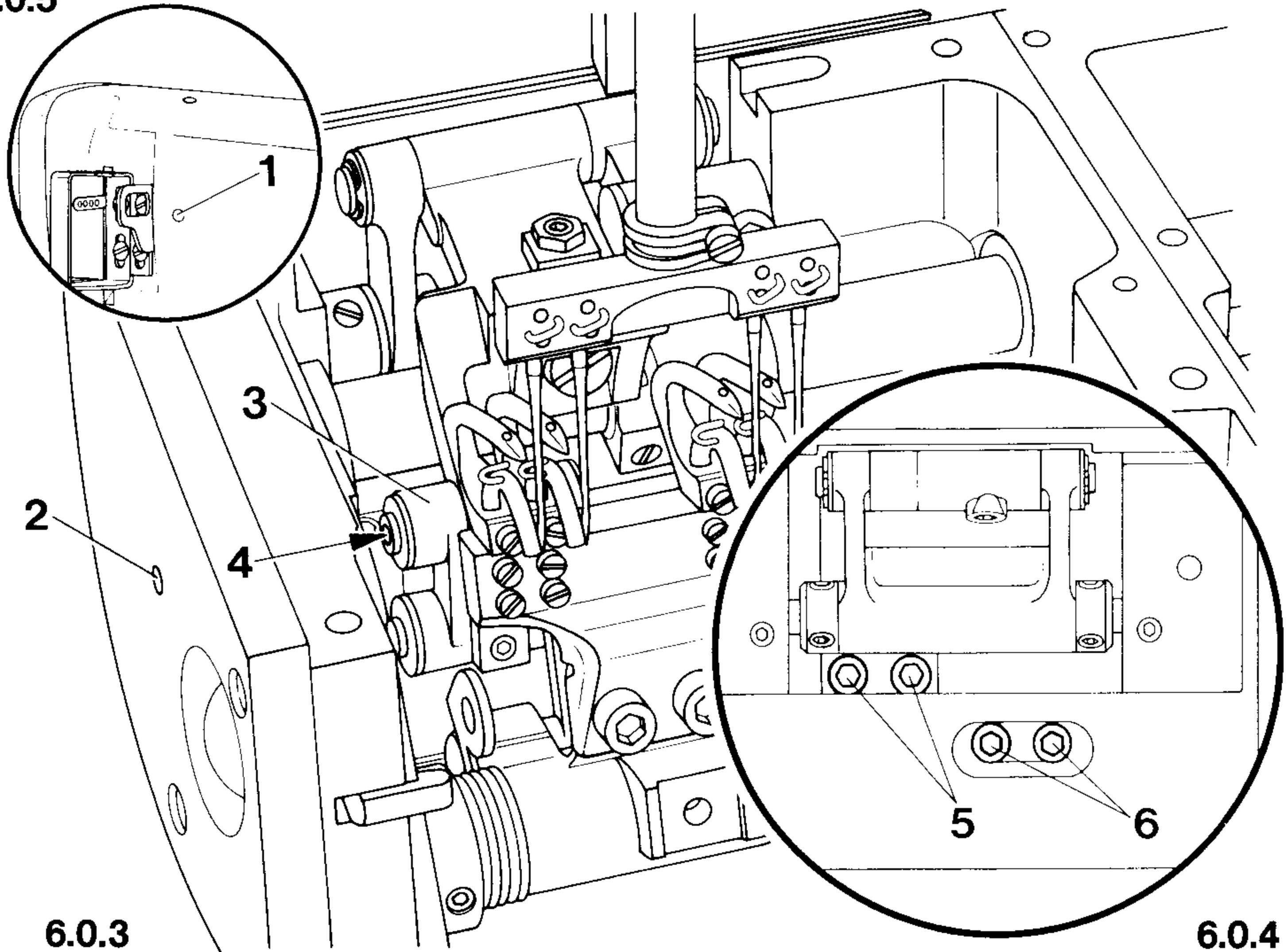

Adjustment:

- 6.2.1 Set the maximum stitch length and position the needle bar at b.d.c.
- .2 Insert the 5-mm adjustment pin in hole 1 (to block the machine).
- .3 **Insert the 6-mm adjustment pin in hole 2, repositioning connecting pin 3 so that the 3-mm end of the adjustment pin fits into hole 4.**
- .4 Tighten screws 5 and 6, and take the adjustment pins out of holes 1 and 2.
- .5 Check this adjustment (see "Setting").

6.3 In sewing direction on machines with 36 mm needle bar stroke (model H)

Setting:

At a needle bar position 0.9 mm before b.d.c. and with the maximum stitch length set, the 6-mm adjustment pin must fit into hole 4 with its 3-mm end.

6.0.8

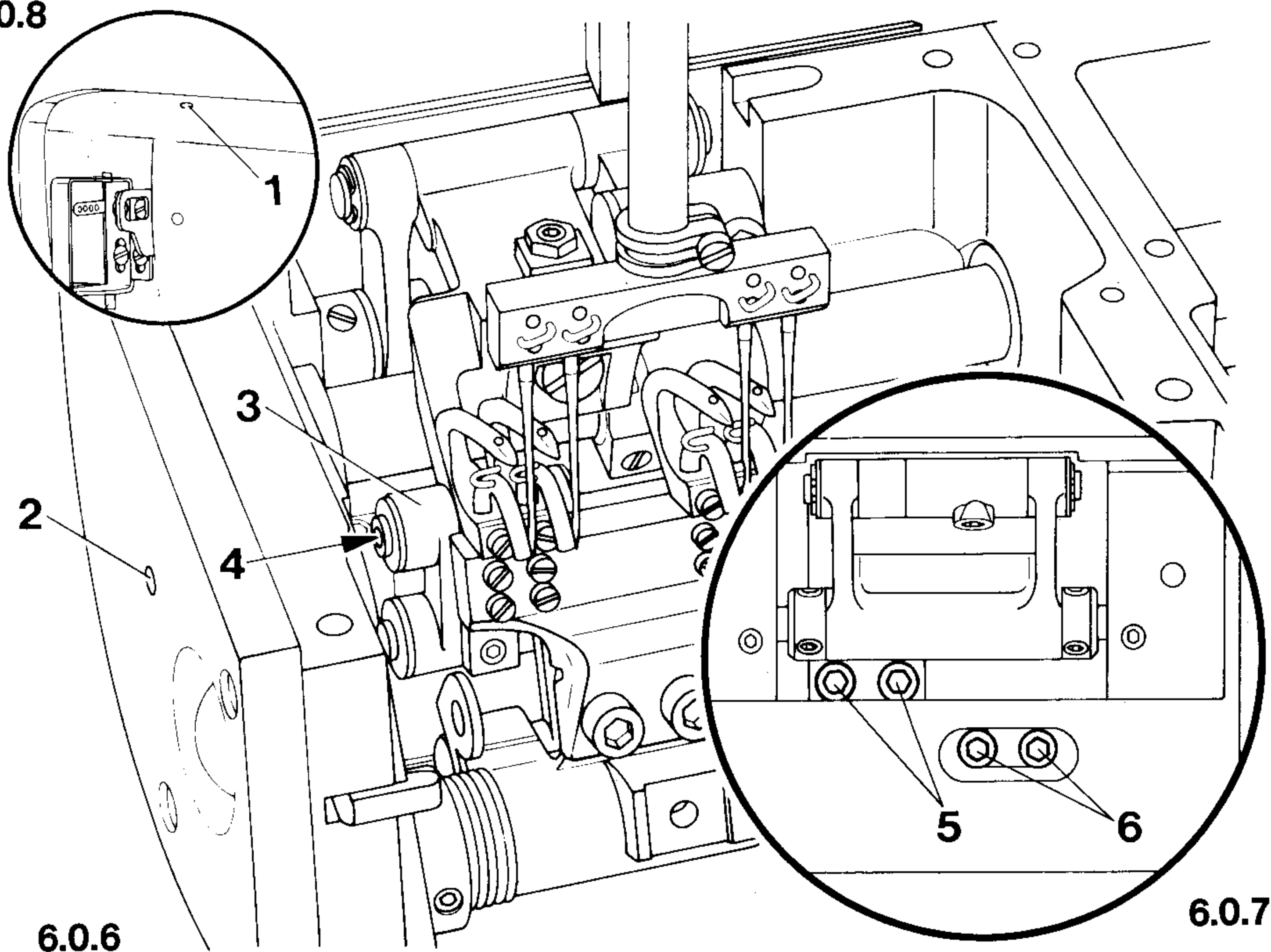

Adjustment:

- 6.3.1 Set the maximum stitch length and position the needle bar 0.9 mm before b.d.c.
- .2 Insert the 5-mm adjustment pin in hole 1 (to block the machine).
- .3 **Insert the 6-mm adjustment pin in hole 2, and reposition connecting pin 3 so that the 3-mm end of the adjustment pin fits into hole 4.**
- .4 Tighten screws 5 and 6, and take the adjustment pins out of holes 1 and 2.
- .5 Check this adjustment (see "Setting").

7 Feed dog height

Setting:

With the needle bar at bottom dead center and the maximum stitch length set, the front teeth of the feed dog must protrude from the needle plate by **1.3 mm** (see Fig. 7.0.3).
When using the adjustment gauge, the teeth of the feed dog must in this position contact the gauge (see Fig. 7.0.4).

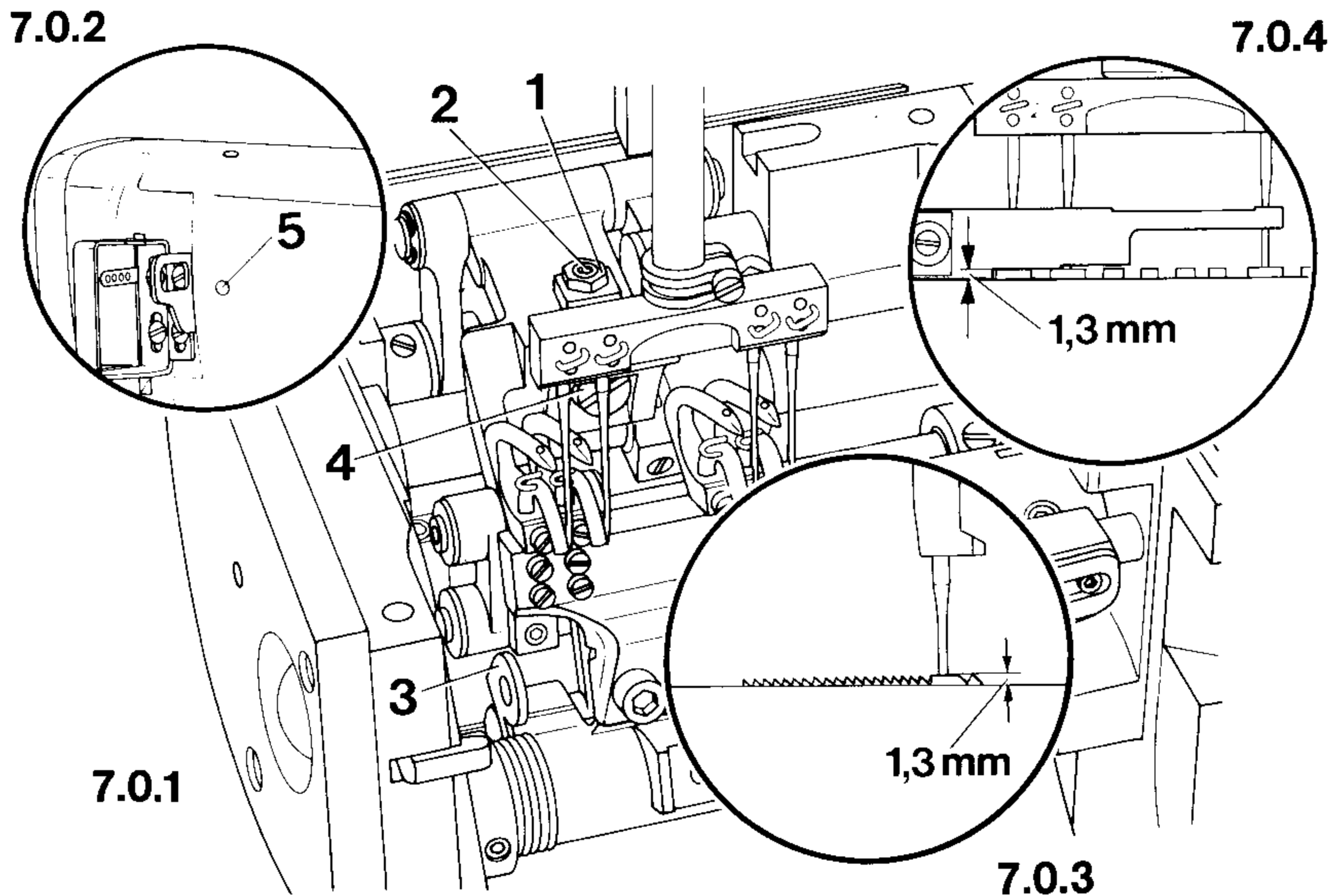

Adjustment:

- 7.1 Unscrew the cover plate and the needle plate.
- .2 Loosen nut 1 and turn out regulating screw 2 by 2 to 3 turns.
- .3 Set needle bar at t.d.c., push locking lever 3 to the left and swing out the looper
- .4 Loosen screw 4, replace cover plate and needle plate, and set the maximum stitch length.
- .5 Set needle bar at b.d.c. and insert the 5-mm adjustment pin in hole 5 (to block the machine).
- .6 Tighten screw 4 just lightly.
- .7 **Tighten regulating screw 2 through the hole in the needle plate until the front teeth of the feed dog (as seen in feeding direction) protrude from the needle plate by 1.3 mm or, when using gauge No. 61-111 643-37, contact the gauge. (The inclination of the feed dog results from this procedure.)**
- .8 Remove cover plate and needle plate.
- .9 Lock regulating screw 2 with nut 1, tighten screw 4, and take the 5-mm adjustment pin out of hole 5.
- .10 Replace cover plate and needle plate and fix them with the screws.
- .11 Check this adjustment (see "Setting").

8 Position of needle in needle hole

8.1 Crosswise to sewing direction

Setting:

Crosswise to the sewing direction, the needles must enter the needle holes in the center (see dash-dot line in Fig. 8.0.4).

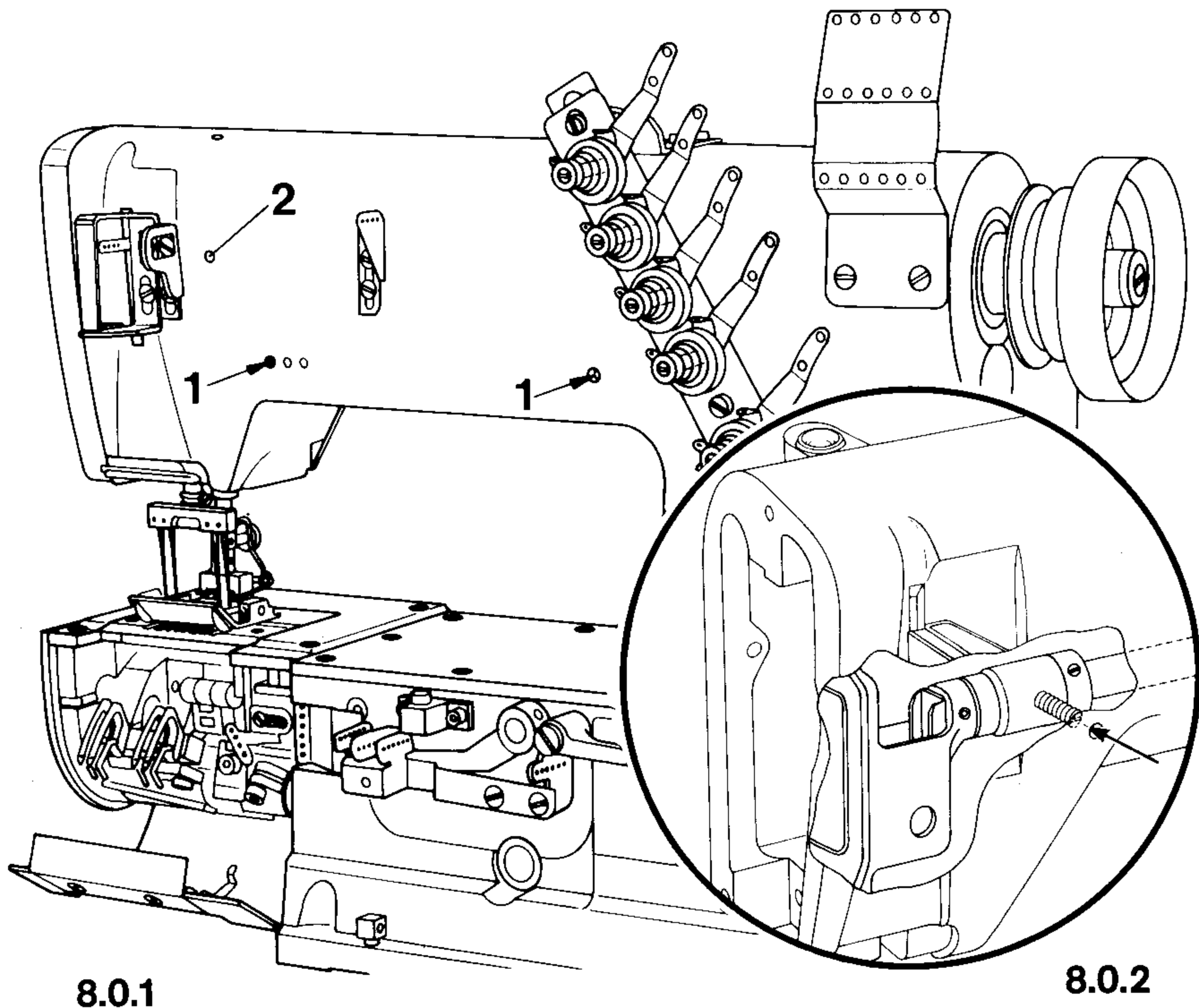

Adjustment:

- 8.1.1 Insert new (system 5640) needles (the long groove must face to the right).
- .2 Loosen screws 1 (see arrows in Figs. 8.0.1 and 8.0.2) and screw 3 (see Fig. 8.0.3).
- .3 Turn the balance wheel to set the needles just above the needle holes.
- .4 Make sure that the needles are the same distance from the front edges of the needle holes (as seen in feed direction); adjust the needle holder, if necessary.
- .5 **Adjust the needle bar frame so that, crosswise to the feed direction, the needles are exactly centered in the needle holes.** If the take-up lever strikes against its cutout, adjust it accordingly.
- .6 Tighten screws 1.

8.2 In sewing direction

Setting:

With the needle bar at b.d.c., there must be a distance of **0.8 mm** between the needles and the front edges of the needle holes.

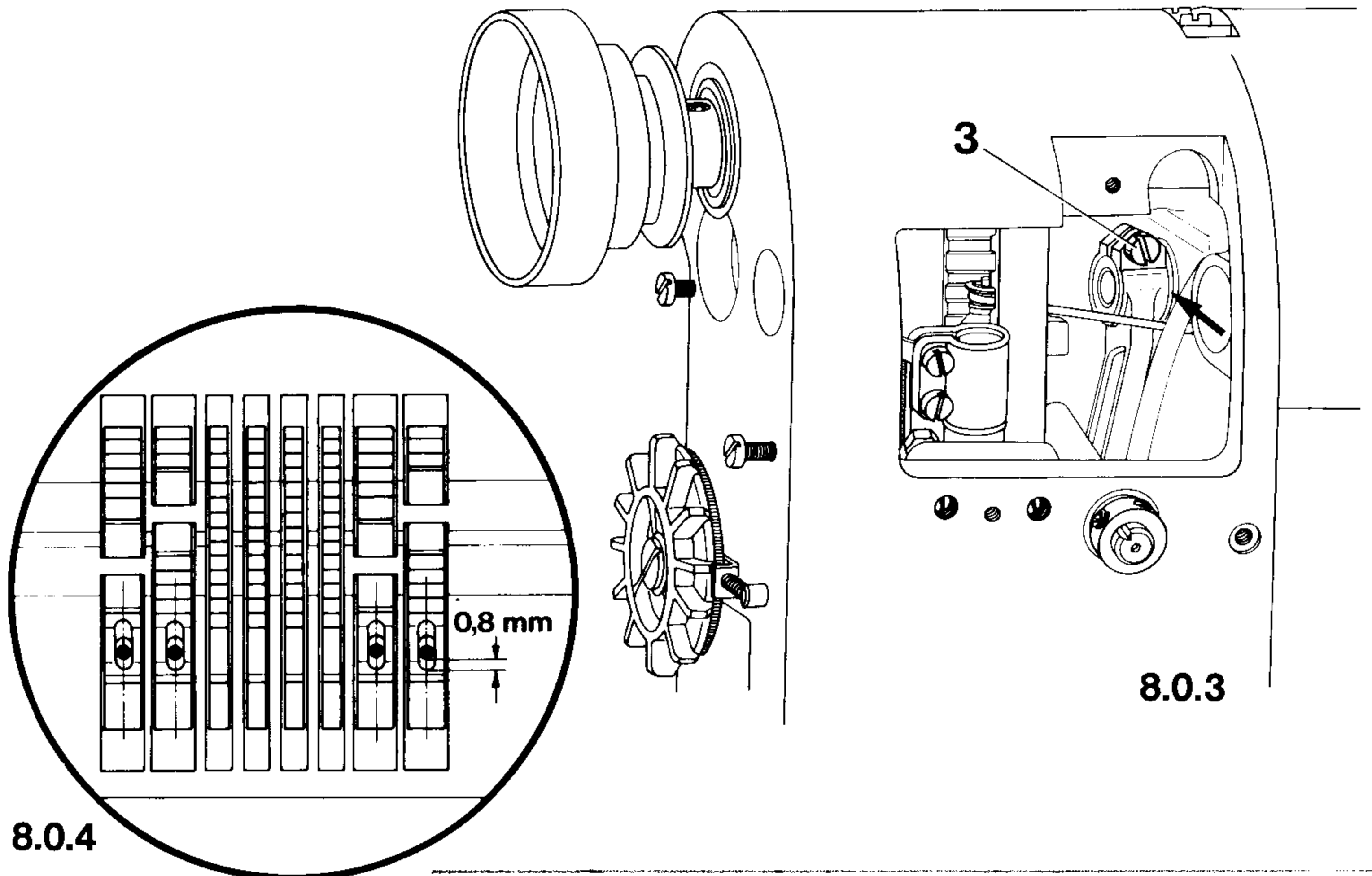

Adjustment:

- 8.2.1 Set the needle bar at b.d.c. and insert the 5-mm adjustment pin in hole 2 (to block the machine).
- .2 Unscrew the cover at the back of the machine.
- .3 **Loosen screw 3 and position the needle bar in sewing direction so that there is a distance of 0.8 mm between the needles and the front edges of the needle holes (Fig. 8.0.4).**
- .4 Tighten screw 3 and take the adjustment pin out of hole 2.
- .5 Check this adjustment (see "Setting").

9 Looper-to-needle clearance

9.1 In sewing direction

Setting:

At a needle bar position 5 mm past b.d.c., the looper points must be positioned exactly at the needle center lines.

Requirement: The loopers must be inserted fully in the guide slot of the looper holders.

9.0.2

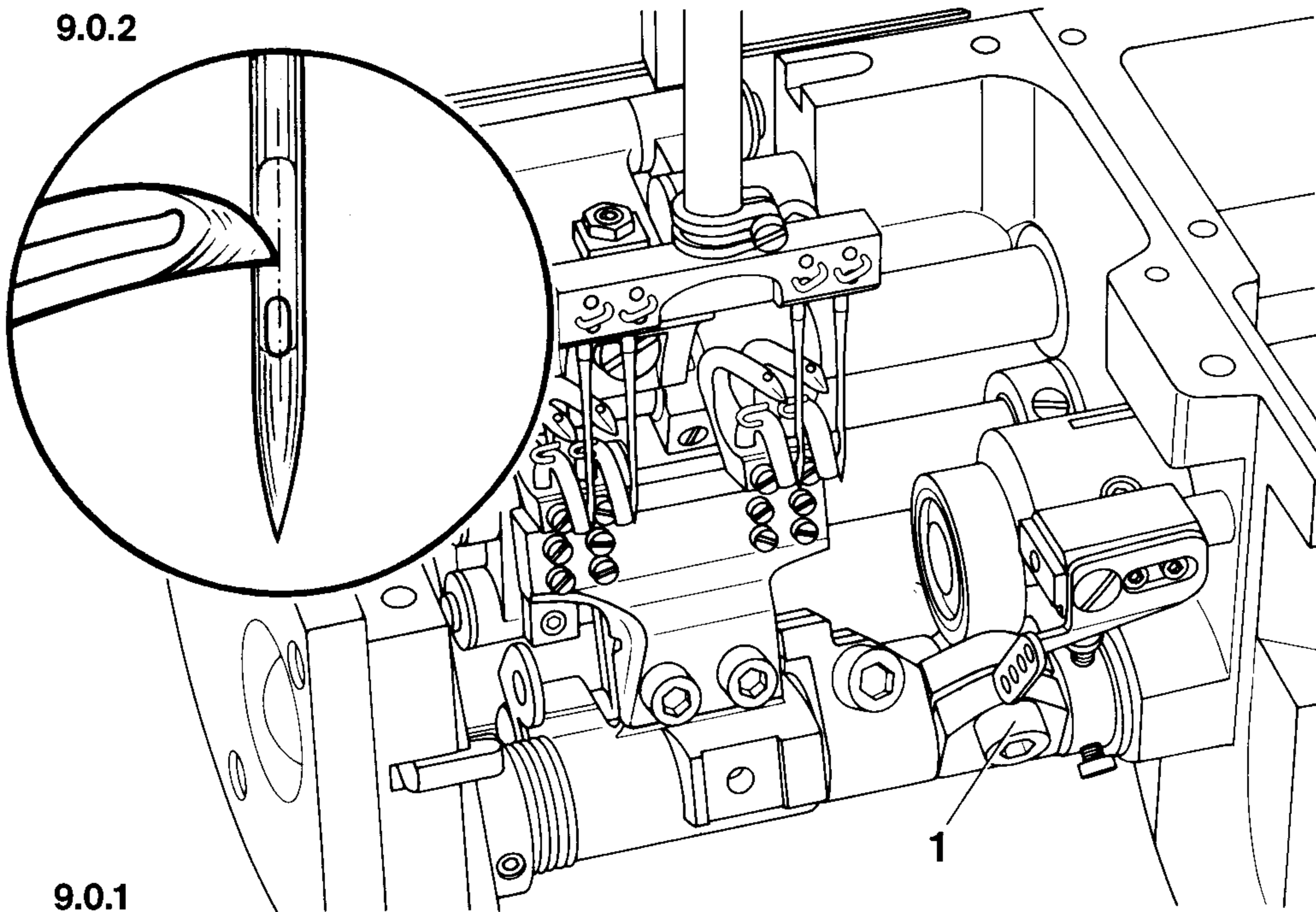

9.0.1

Adjustment:

- 9.1.1 Remove cover plate with needle plate and unscrew the feed dog.
- .2 Set needle bar at a position 5 mm past b.d.c. and loosen screw 1.
- .3 Adjust the looper holders so that the looper points are opposite the needle center lines.
- .4 Tighten clamp screw 1.

9.2 Crosswise to sewing direction

Setting:

When the looper points are opposite the needle center lines, there must be a clearance of **0.1 mm** between looper points and needles.

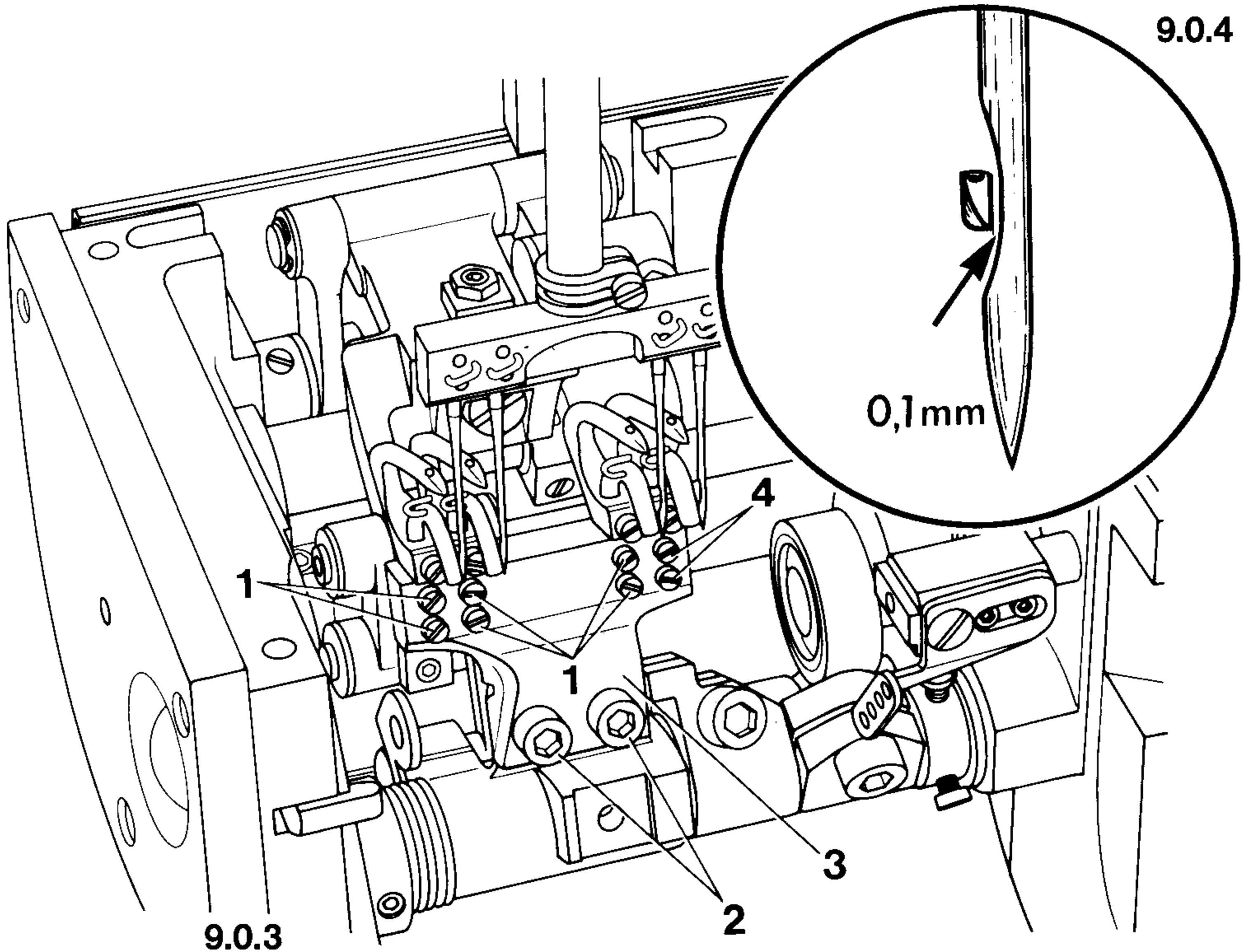

Adjustment:

- 9.2.1 Loosen screws 1 and take out the loopers (except the right one). The right looper is placed in a groove in holder 3.
- .2 Loosen screws 2.
- .3 Making sure that the looper point is opposite the needle center line, re-position looper holder 3 so that the looper point contacts the needle.
- .4 Tighten screws 2.
- .5 Loosen screws 4 of the right looper just a little.
- .6 **Adjust the looper so that between its point and the needle there is a clearance of 0.1 mm.**
- .7 Tighten screws 4.
- .8 Replace the other loopers and tighten screws 1 lightly.
- .9 **Adjust the loopers so that between their points and the needles there is a clearance of 0.1 mm.**
- .10 Tighten screws 1.
- .11 Check this adjustment (see "Setting").

10 Needle bar height

Setting:

When the points of the advancing loopers are flush with the fronts of the needles, there must be a clearance of **1 to 1.2 mm** between the underside of the looper blade and the top of the needle eye.

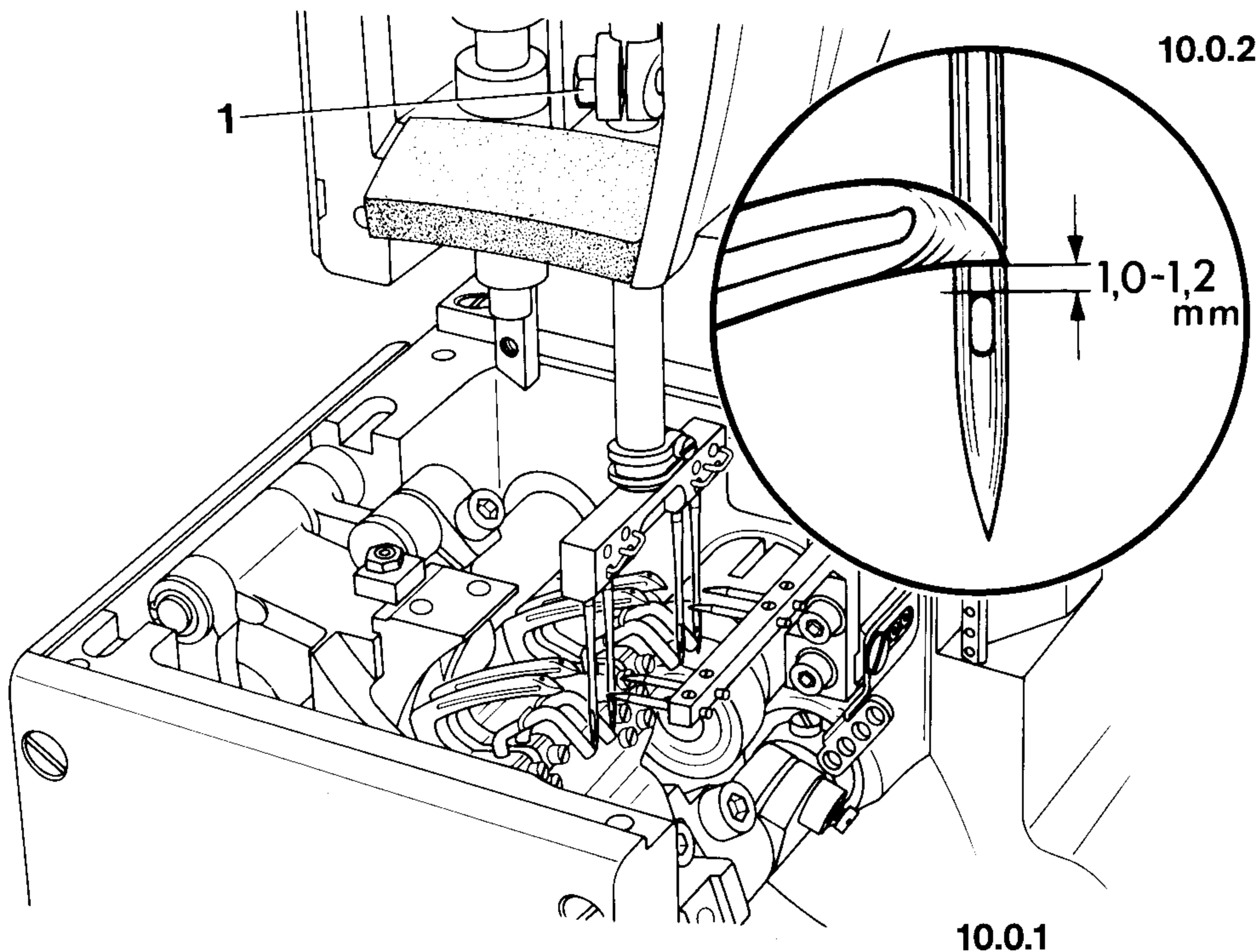

Adjustment:

- 10.1 Turn the balance wheel until the points of the advancing loopers are flush with the front of the needles.
 - .2 Loosen clamp screw 1.
 - .3 **Adjust the height of the needle bar, without turning it, so that there is a clearance of 1 to 1.2 mm between the underside of the looper blade and the top of the needle eye.**
 - .4 Tighten clamp screw 1.
 - .5 Check this adjustment (see "Setting"), and also check the setting under section 9.2.
- If the take-up lever strikes against its slot, adjust its height accordingly.

11 Spreader position

11.1 In sewing direction

Setting:

The spreader points must have a **45°**-inclination to the right, and they must be **13.5 mm** away from the spreader bracket.
Also, with the maximum stitch length set and the needle bar at b.d.c., the distance from the spreader points to the needle centers must be **2 to 3 mm**.

Note:

The looper threads must be retained by the spreaders until the needle points are flush with the underside of the loopers.

However, before the needle thread drops off the looper, the looper thread must have dropped off the spreader.

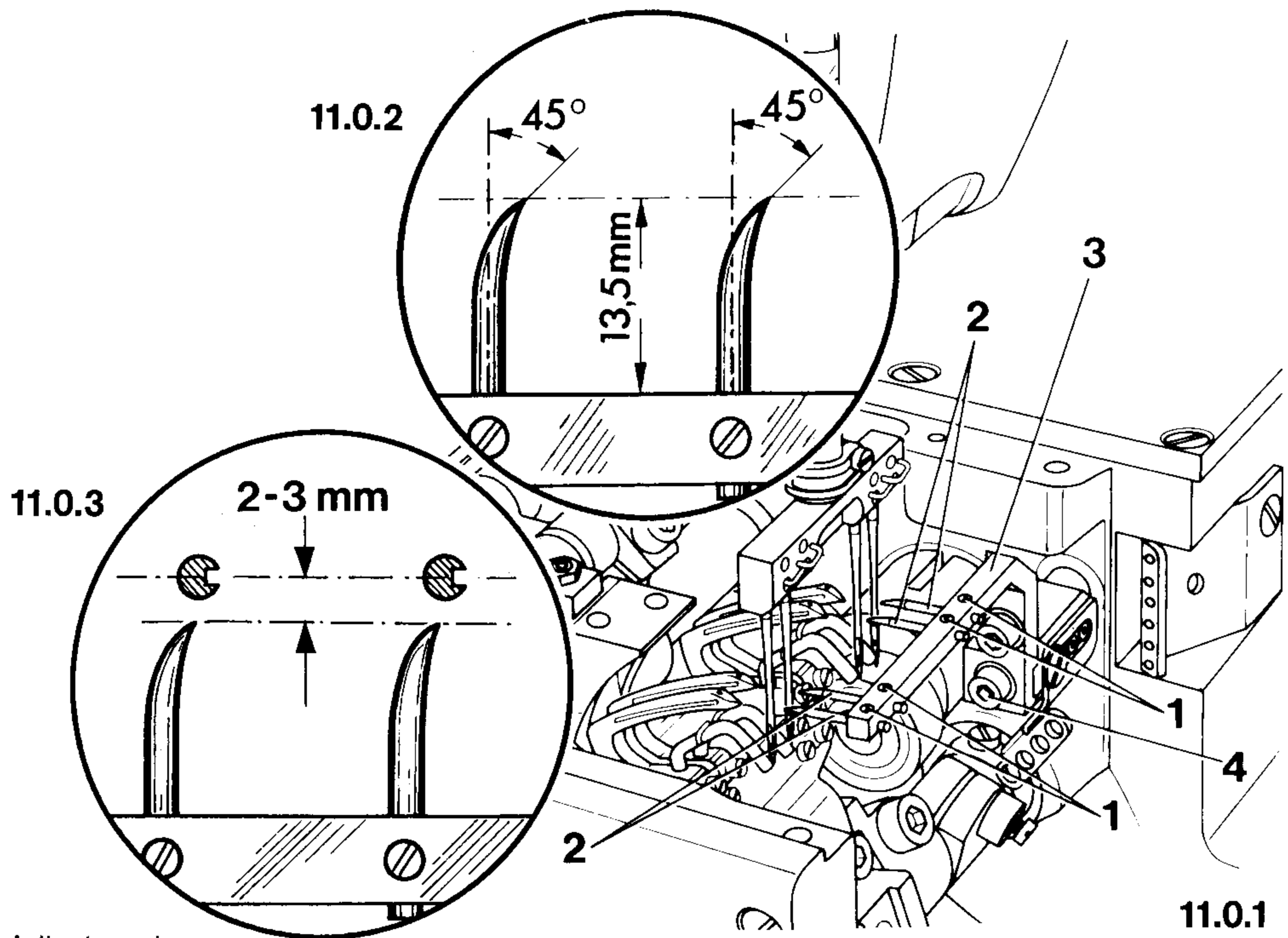

Adjustment:

- 11.1.1 Set the maximum stitch length and loosen screws 1.
- .2 **Position spreaders 2 so that between their points and spreader brackets 3 there is a distance of 13.5 mm.**
- .3 **In this position, turn spreaders 2 so that their points are inclined 45° to the right.**
- .4 Tighten screws 1.
- .5 Loosen screw 4 and set needle bar at b.d.c.
- .6 **Adjust spreader bracket 3 so that there is a distance of 2 to 3 mm between the spreader points and the needle centers.**
- .7 Tighten screw 4.
- .8 Check this adjustment (see "Setting").

11.2 Crosswise to sewing direction and looper

Setting:

The spreader points must not touch the loopers in any position. Between the points of spreaders **3** and the loopers there must be a clearance of **0.1 mm**.

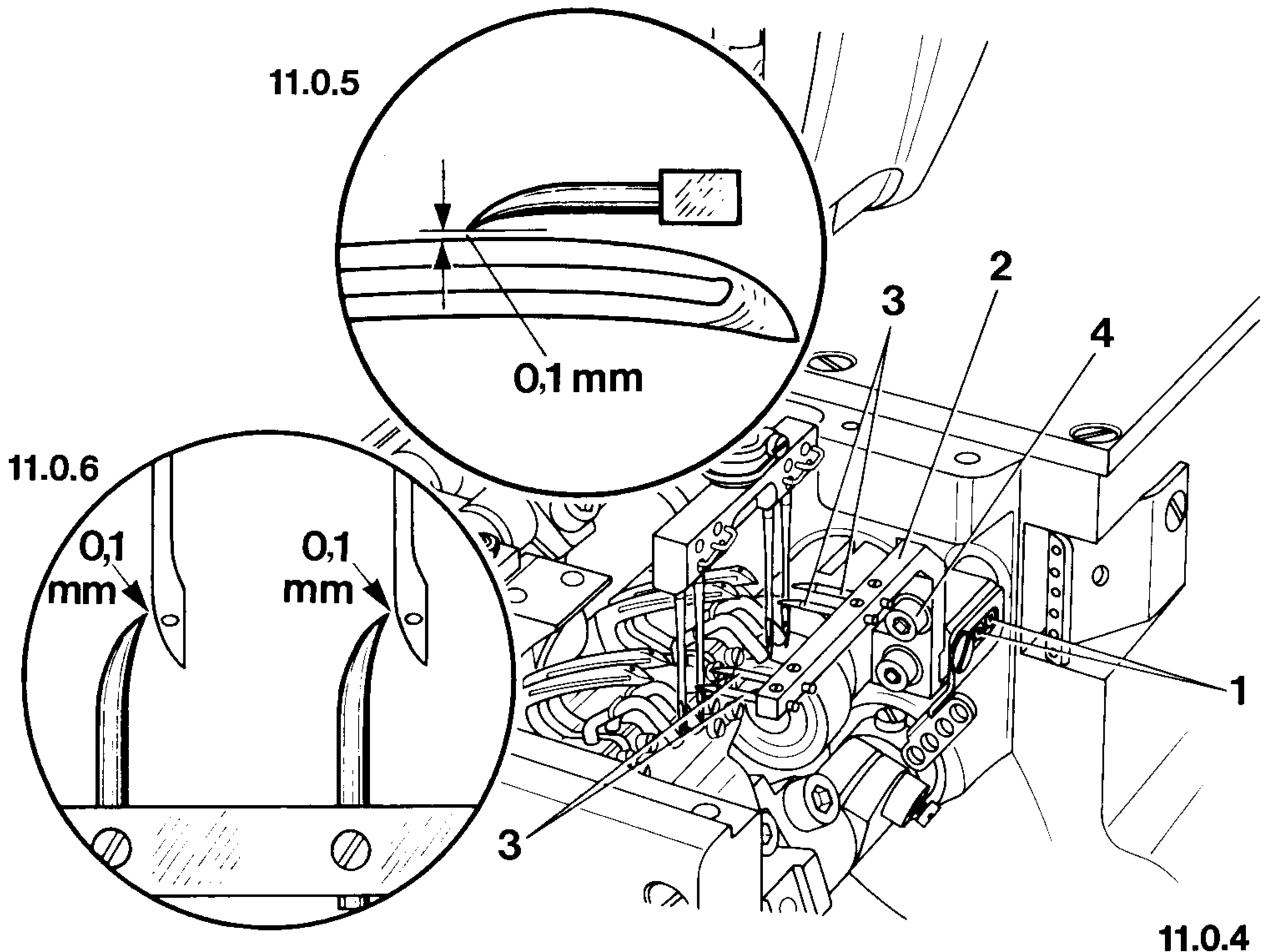

Adjustment:

- 11.2.1 Loosen screws **1**.
- .2 Making sure that the spreader points do not collide with the loopers, set spreader bracket **2** at its left point of reversal by turning the balance wheel.
- .3 Turn the balance wheel a little forwards or backwards until the looper eyes are positioned beside the points of spreaders **3**.
- .4 **Position spreader bracket 2 so that between the points of spreaders 3 and the loopers there is a clearance of 0.1 mm.**
- .5 Tighten screws **1**.
- .6 Loosen screw **4** and turn the balance wheel until spreaders **3** are positioned above the backs of the loopers.
- .7 **Adjust the height of spreader bracket 2 so that the spreader points are about 0.1 mm above the backs of the loopers.**
- .8 Tighten screws **4**.
- .9 Check this adjustment (see "Setting").

12

Needle guard

Setting:

When the points of the advancing loopers are opposite the needle center lines, the undersides of needle guards 2 must be about 0.5 mm above the needle points and rest lightly against the needles.

12.0.1

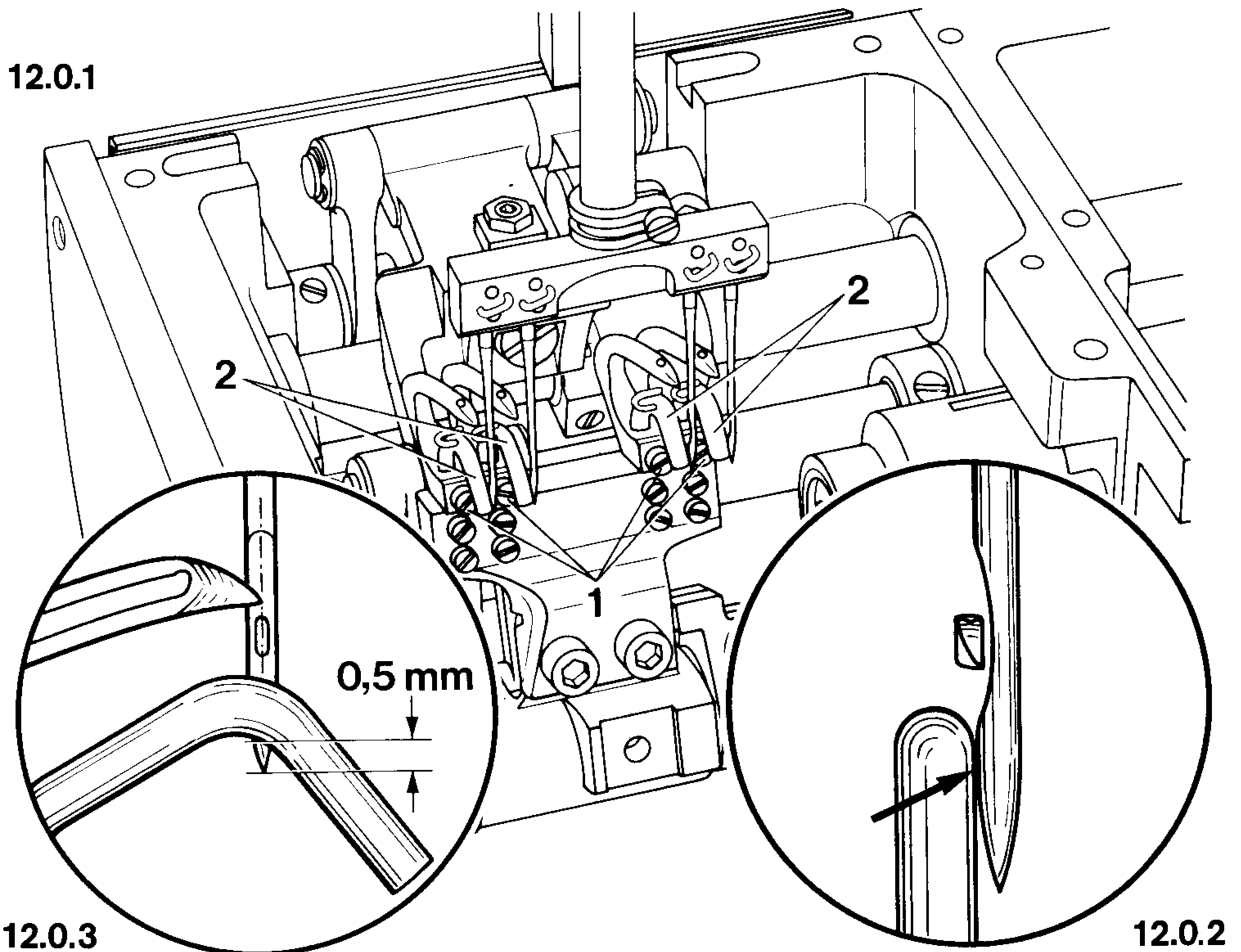

Adjustment:

- 12.1 Loosen screws 1.
- .2 Turn the balance wheel until the points of the advancing loopers are opposite the needle center lines (see Fig. 12.0.3).
- .3 **Adjust needle guards 2 so that their undersides are about 0.5 mm above the needle points (see Fig. 12.0.3) and that the guards rest lightly against the needles, however, without deflecting them (see arrow in Fig. 12.0.2).**
- .4 Tighten screws 1.
- .5 Check this adjustment (see "Setting").

13 Regulating the looper thread

Setting:

With thread puller 1 at t.d.c., there must be a distance of **20 mm** between puller 1 and the base plate surface. With thread puller 1 at t.d.c., the difference in height between the top edges of thread pullers 1 and 5 must be as follows:
 for stitch lengths up to 3.5 mm **9 mm**;
 for stitch lengths between 3.5 and 4.5 mm **6 mm**.
 For stitch lengths over 4.5 mm, the eyes of thread puller 1 and thread puller 5 must be aligned with each other.

Note:

The position of the thread guides depends on the material and thread used. Therefore, the following adjustment data can only be regarded as basic values.

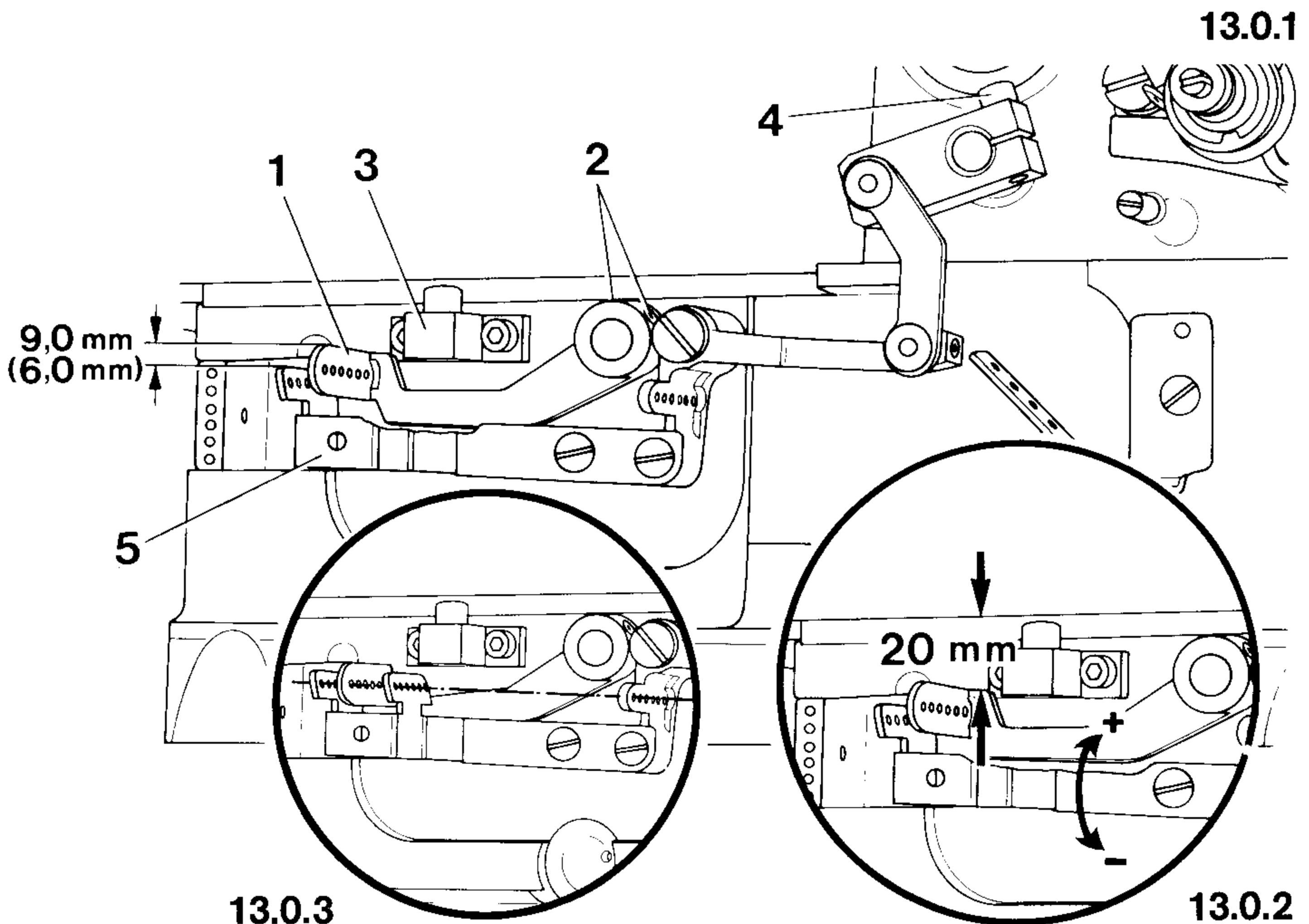

Adjustment:

- 13.1 Set the maximum stitch length.
- .2 Set thread puller 1 at t.d.c.
- .3 Loosen screws 2 and **position thread puller 1 so that between it and the surface of the base plate there is a distance of 20 mm** (Fig. 13.0.2).
- .4 Tighten screws 2.
- .5 Loosen screw 4.
- .6 **Adjust thread puller 5 according to "Setting"**.
- .7 Tighten screw 4.
- .8 If the seam requires more or less thread, thread guide 5 must be moved in ⊕ or ⊖ direction, respectively.

14 Needle-thread regulation and take-up lever guard

Setting:

With the needle bar at b.d.c., there must be a clearance of 1 mm between take-up lever 3 and take-up lever guard 2. The retaining screws must be centered in the elongated holes of thread guides 5 and 7.

Note:

The positions of the needle thread guides and the thread regulator depend on the stitch length and the material. Therefore, the adjustment data can only be regarded as basic values.

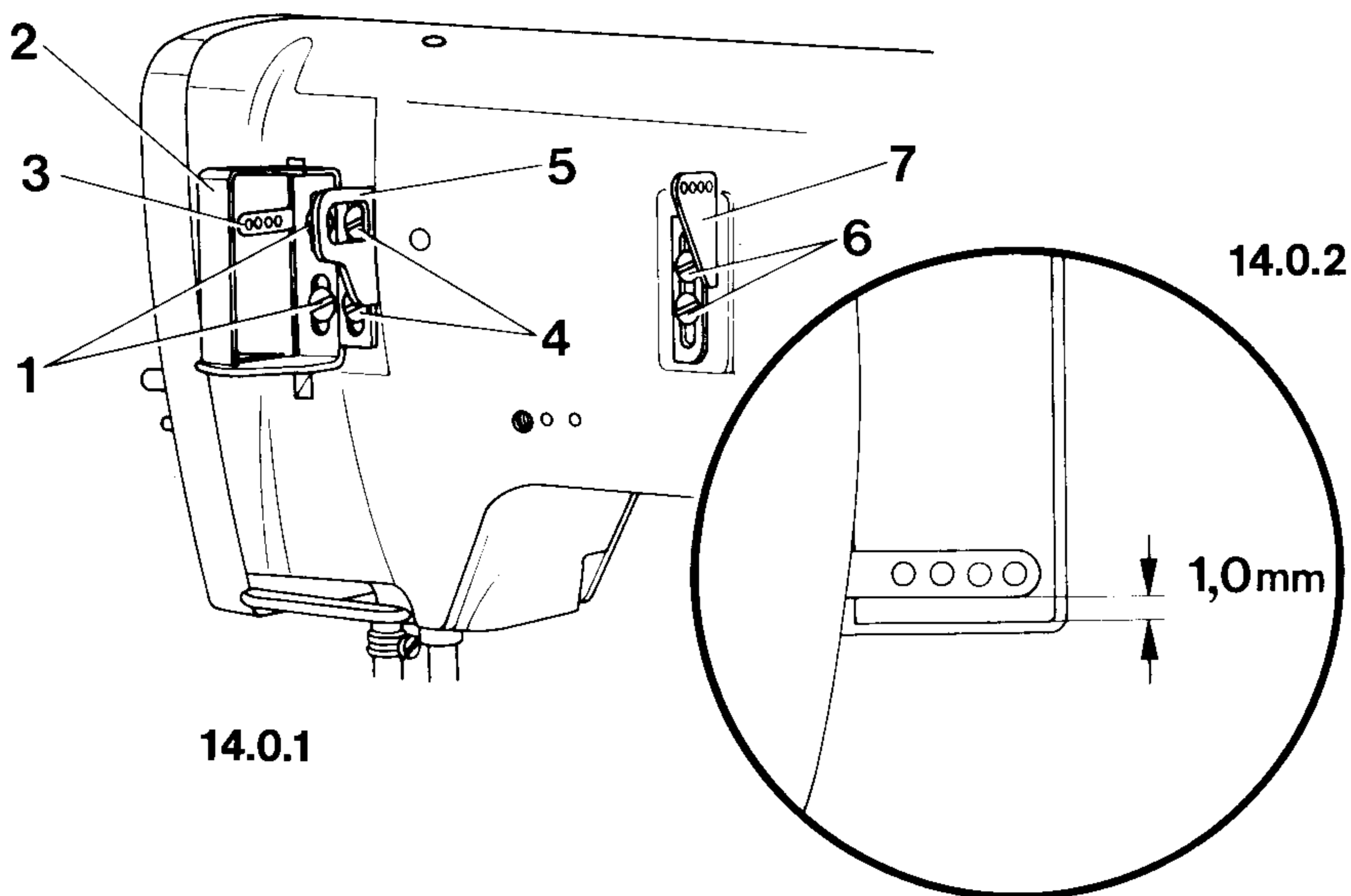

Adjustment:

- 14.1 Set needle bar at b.d.c. and loosen screws 1.
- .2 **Position take-up lever guard 2 so that between it and take-up lever 3 there is a clearance of 1 mm.**
- .3 Tighten screws 1, making sure that take-up lever 3 is positioned horizontally in the middle of the take-up lever guard.
- .4 Loosen screws 4 and **position thread regulator 5 so that screws 4 are centered in the elongated holes.**
- .5 Tighten screws 4.
- .6 Loosen screws 6 and **position thread guide 7 so that screws 6 are centered in the elongated holes.**
- .7 Tighten screws 6.

Setting:

With the maximum stitch length set, eccentric 1 must rest against stop crank 2 (see arrow in Fig. 15.0.1).

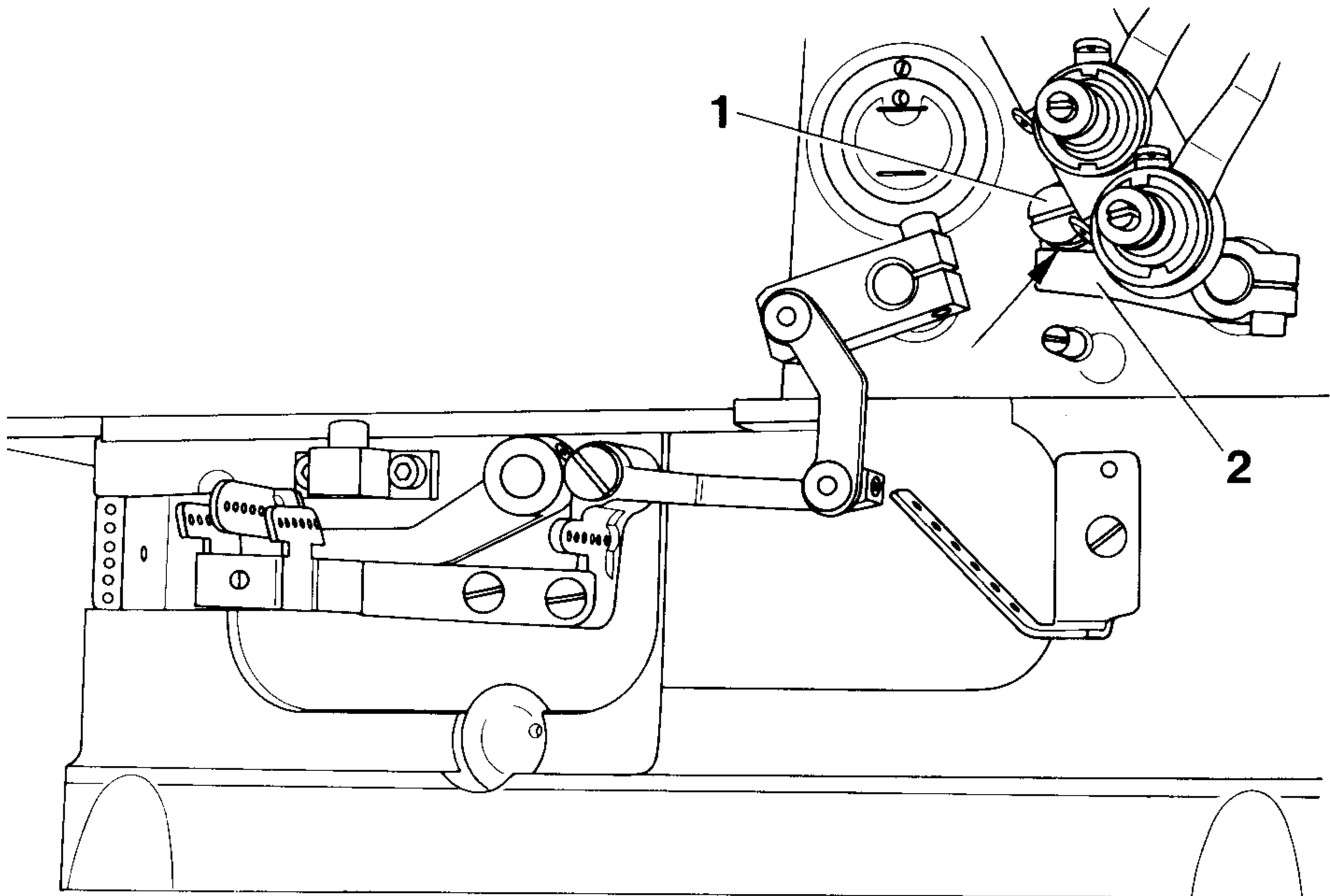

15.0.1

Adjustment:

- 15.1 Loosen locknut behind eccentric 1.
- .2 Turn eccentric 1 until its lobe points up.
- .3 Set the maximum stitch length.
- .4 **Turn eccentric 1 so that it rests against crank 2** (see arrow in Fig. 15.0.1).
- .5 Lock eccentric 1 with the nut behind it.

Setting:

With presser bar lifter **3** raised, there must be a clearance of **7 mm** between presser foot and needle plate. On machines with floating foot, raising presser bar lifter **3** must first raise the presser bar by **0.3 mm** before the presser foot begins to lift clear of the needle plate. On machines with plain hinged presser foot, there must be a clearance of **0.3 mm** between collar **6** and presser bar bushing **7** when the feed dog is lowered and the presser foot is resting on the needle plate.

16.0.3

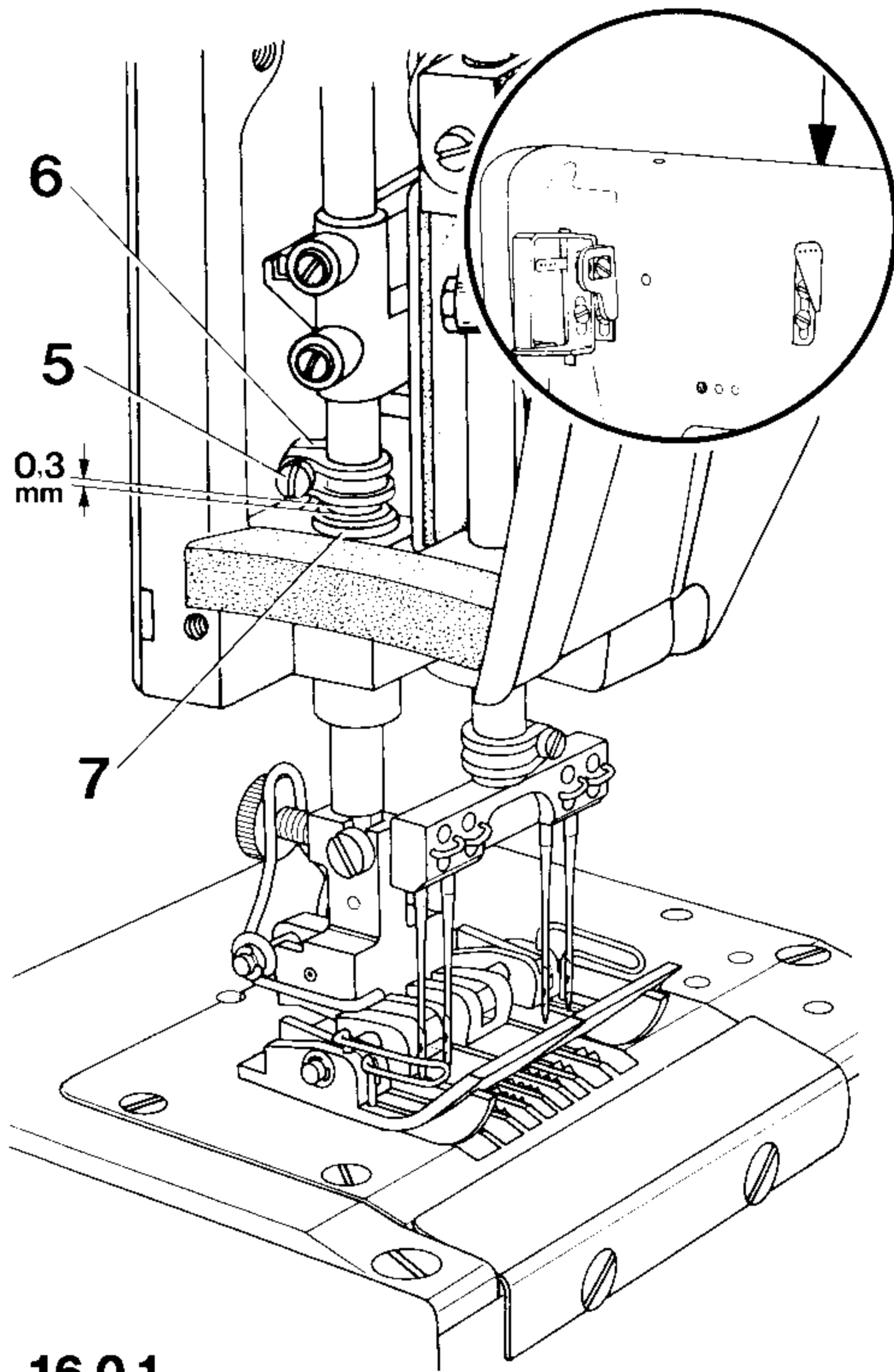

16.0.1

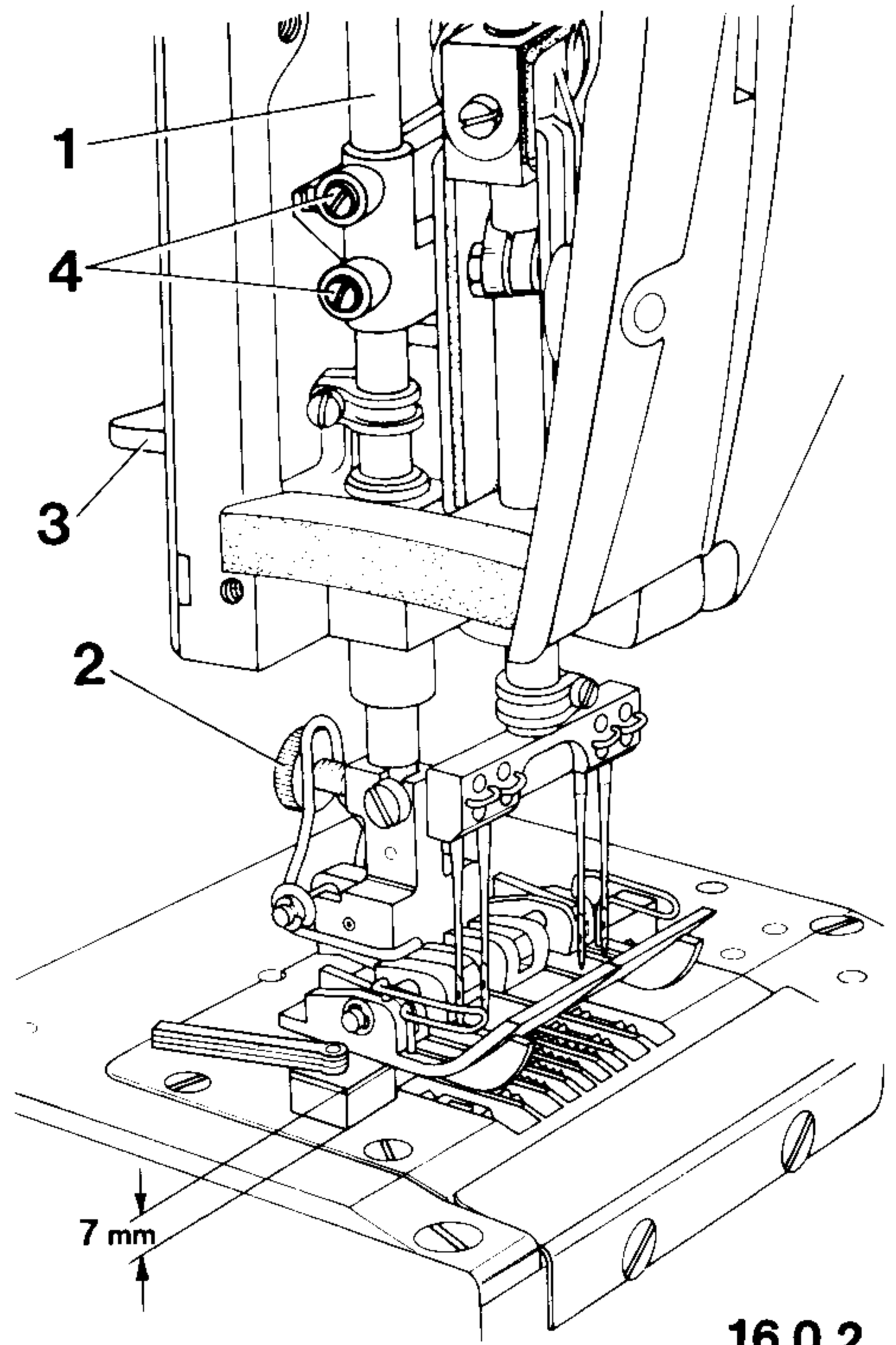

16.0.2

Adjustment:

- 16.1 Set needle bar at t.d.c.
- .2 Reduce the pressure on presser bar 1 by turning out the regulating screw (see arrow in Fig. 16.0.3).
- .3 Refit feed dog, cover plate with needle plate, and presser foot.
- .4* Turn knurled nut 2 until its face side is flush with the screw.
- .5 Raise the presser bar lifter, loosen screws 4, and place the 7-mm adjustment gauge under the presser foot hinge.
- .6 Push presser bar 1 down until the presser foot rests lightly on the adjustment gauge (without pressure), and is parallel with the needle plate cutout as seen in sewing direction. (The needles must be centered in the needle holes of the presser foot.)
- .7 Tighten screws 4 and take the adjustment gauge out from under the presser foot.
- .8* Lower presser bar lifter 3 just sufficiently to allow the presser foot to contact the needle plate with its entire straight sole without exerting any pressure.
- .9* In this position, loosen screw 5, push collar 6 down until it contacts presser bar bushing 7, then tighten screw 5 again.
- .10 **On machines with plain hinged presser foot adjust collar 6 so that there is a clearance of 0.3 mm between it and presser bar bushing 7 when the feed dog is lowered and the presser foot is resting on the needle plate.**
- .11 Turn in the pressure regulating screw (see arrow in Fig. 16.0.3) to increase the pressure on the presser bar so that proper feeding is ensured even at top speed.
- .12* Turn knurled nut 2 to adjust the pressure so that proper feeding is ensured even at varying speeds (and the material does not flag).
- .13 Screw on the face plate.

* = Does not apply to presser feet without knurled nut 2.

Setting:

When the knee lever is fully actuated, the presser bar lifter must drop by its own weight, and the presser foot must lift clear of the needle plate by a little more than **7 mm**.
Also, the knee lever must have a slight amount of play before lifting the presser foot.

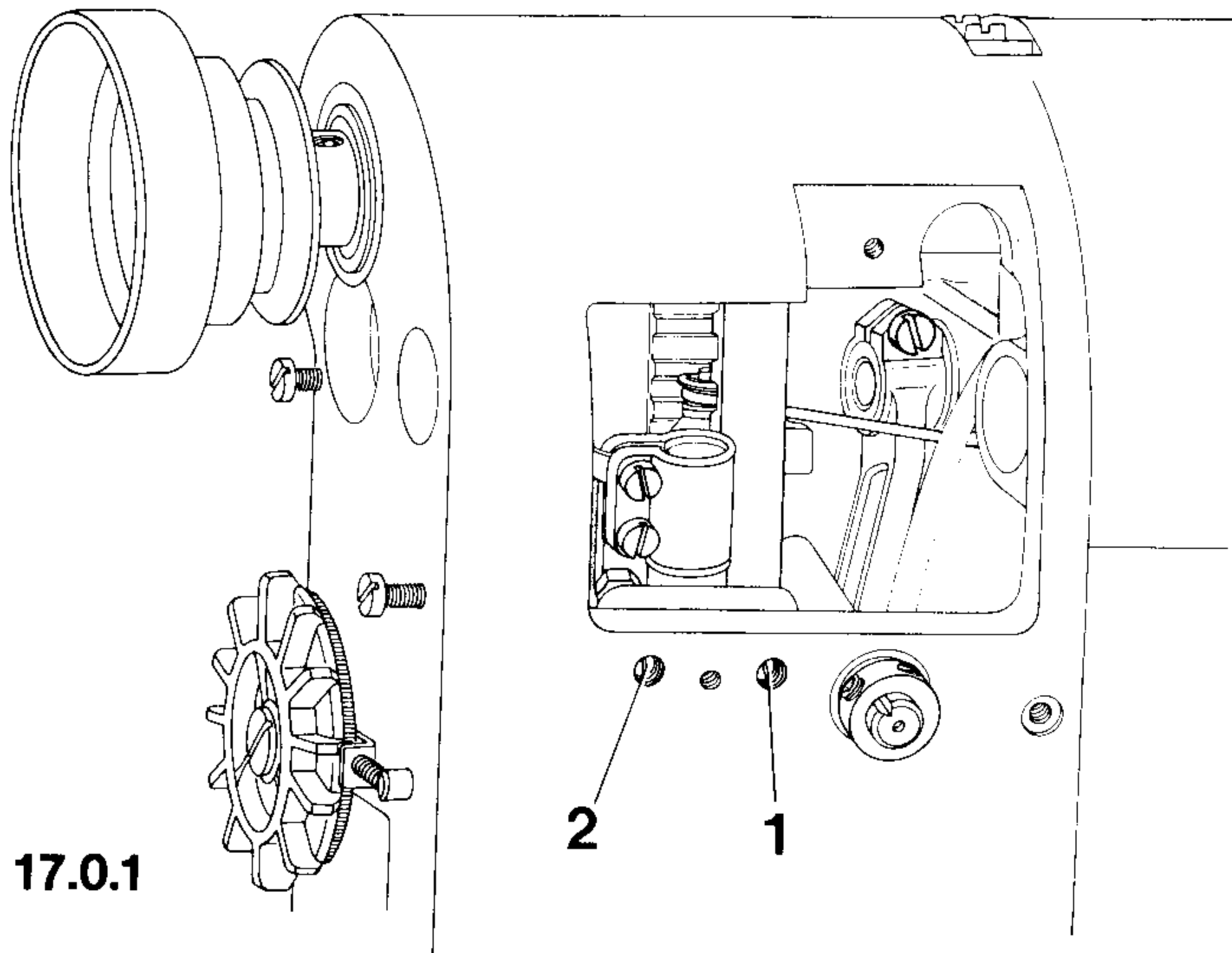

Adjustment:

- 17.1 Make sure that the knee lever is inserted in its connection, then lower the presser foot onto the needle plate by means of the lifting lever.
- .2 Loosen nut of screw 1 and turn out screw by a few turns.
- .3 **Turn in screw 1 until the presser foot begins to lift from the needle plate.**
- .4 Turn screw 1 back by about half a turn and tighten its locknut. (In this position, the knee lever must be at about right angles to the base plate.)
- .5 Loosen nut of screw 2 and turn the screw out by a few turns.
- .6 **Raise the presser foot with the lifting lever and place the 10-mm-thick adjustment gauge under the presser foot from the rear.**
- .7 **Push the knee lever to the right until the presser foot begins to lift off the adjustment gauge.**
- .8 Hold the knee lever in this position and turn the left screw in as far as it will go.
- .9 Release the knee lever, turn screw 2 back by about half a turn and lock it with the nut.
- .10 Check this adjustment (see "Setting").

18 Tension release

Setting:

When the presser foot is raised with the knee lever by about 10 mm, thread tensions **6** must be released.

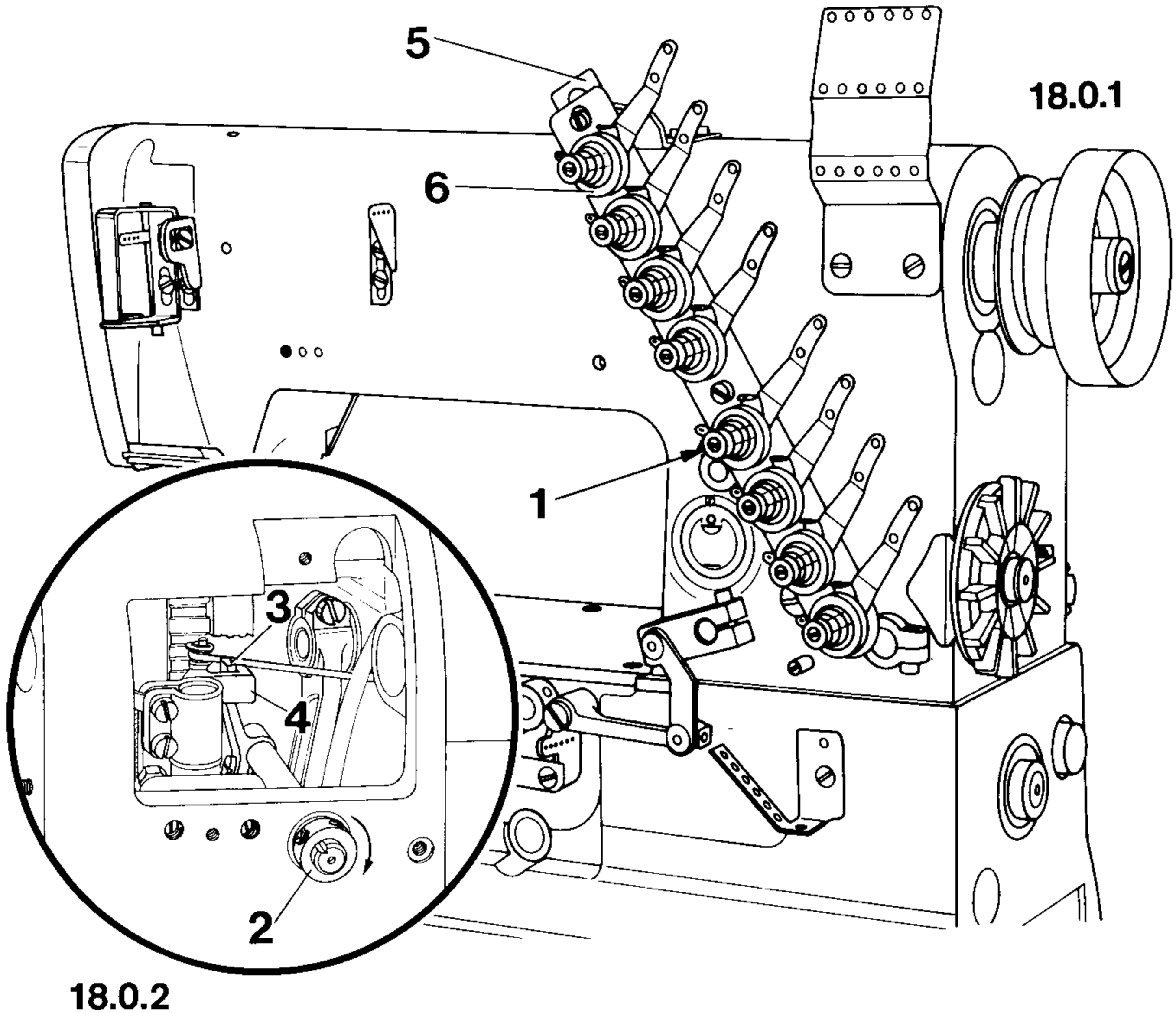

Adjustment:

- 18.1 Loosen screw **1**.
- .2 Raise the presser foot with the knee lever by about 10 mm and retain this position.
- .3 Turn fixing collar **2** (in direction of arrow) until crank **3** is resting against the angle piece of crank **4**.
- .4 In this position, push tension release plate **5** fully downwards, then have it return by about **1 mm**.
- .5 Tighten clamp screw **1**.
- .6 Check this adjustment (see "Setting").
- .7 Screw on cover plate at the back of the machine.

