

PFAFF

3822 -1/22 -1/24

Instruction manual

The following other manuals are required:

- Service manual
for thread trimmer -900/51
of the 480 Series
- Motor control instructions
-1/22 - Quick digital P 40 K2
-1/24 - Quick digital Q 40 SE

Notes on safety

- The machine must only be commissioned in full knowledge of the instruction manual and operated by persons with appropriate training.
- Before putting into service also read the safety notes and the instruction manual of the motor supplier.
- The machine must be used only for the purpose intended.
Use of the machine without the safety devices belonging to it is not permitted.
- When gauge parts are exchanged (e.g. needle, presser foot, needle plate, feed dog and bobbin) during threading, when the workplace is left, and during service work, the machine must be isolated from the mains by switching off the main switch or disconnecting the mains plug.
- On mechanically operated clutch motors without start inhibitor it is necessary to wait until the motor has stopped.
- General servicing work must be carried out only by appropriately trained persons.
- Repairs, conversion and special maintenance work must only be carried out by technicians or persons with appropriate training.
- For service or repair work on pneumatic systems the machine must be isolated from the compressed air supply system.
Exceptions to this are only adjustments and function checks made by appropriately trained technicians.
- Work on the electrical equipment must be carried out only by electricians or appropriately trained persons.
- Work on parts and systems under electric current is not permitted, except as specified in regulations EN 50110.
- Conversions or changes to the machine must be made only on adherence to all safety regulations.
- For repairs, only replacement parts approved by us must be used.
- Commissioning of the sewing head is prohibited until such time as the entire sewing unit is found to comply with EC regulations.

Meanings of the symbols:



Danger spot!
Items requiring special attention.



Danger of injury to operative
service staff.

Be sure to observe and adhere to these notes!

Contents

	Notes on safety	2
	Meaning of the symbols	2
	Purpose of application of the PFAFF 3822-1/22 and PFAFF 3822-1/24	5
1	Specifications	5
2	Controls and indicators	6
	Pedal functions	6
	Twelve-key keypad	7
3	Examination before commissioning	8
4	Setting up the machine	8
5	Compressed air and electrical connection	8
	.1 Compressed air	8
	.2 Electrical	8
6	Switching the machine on	8
7	Switching the machine off	8
8	Checks	10
	.1 Oil level of sewing machine	10
	.3 Rotating direction	10
9	Insert the needle	12
10	Winding the bobbin thread	12
11	Regulating the winding thread tension	12
12	Removing the bobbin case	14
13	Threading the bobbin thread tension	14
14	Regulating the bobbin thread tension	14
15	Inserting the bobbin case	14
16	Threading the needle thread	14
17	Adjusting the needle thread tension	14
18	Checking and adjusting aid	16
19	Needle to needle hole	16
20	Neutral position of bottom feed dog	18
21	Stitch length limitation	18
22	Bottom feed actuating lever	18
23	Bottom feed dog stroke	20
24	Bottom feed lifting motion	20
25	Bottom feed dog height	22
26	Spacing between presser foot and needle plate	22
27	Adjusting the floating foot	24
	.1 on 3822-1/24	24
	.1.1 Height adjustment	24
	.1.2 Distance screw	24
	.2 on 3822-1/22	24
28	Top feed driving link	26
29	Top feed neutral position	26
30	Top feed driving motion	28
31	Top feed stroke	28
32	Top feed lifting motion	30
33	Top feed foot position	30
34	Top feed synchronization	30
35	Stitch length compensation	32
36	Eccentric hook shaft bearing	32
37	Needle height, needle rise and hook clearance	34
38	Bobbin case opener height	34
39	Bobbin case opener position	36
40	Bobbin case opener movement	36
41	Needle thread tension release	38
42	Thread check spring and thread regulator	38
43	Bobbin winder	38
44	Position of vibrating presser to lifting presser	40
45	Pressure of vibrating and lifting pressers	40
46	Dismantling and re-fitting the take-up lever	42
	.1 Dismantling	42
	.2 Re-fitting	42

47	Automatic backtacking system	44
48	Stitch condensation system	44
49	Edge trimming system	46
.1	Trimming movement	46
.2	Neutral point	46
.3	Knife height	46
.4	Positioning the top knife in sewing direction	46
.5	Positioning the top knife crosswise to sewing direction	46
.6	Adjusting the stop eccentric	46
50	Step-cut trimming mechanism	50
.1	Note on motor control	50
.2	Preparations for adjusting the trimmer	50
.3	Setting the longest knife stroke	50
.4	Setting the top reversal point of the knife	50
.5	Positioning the top knife bracket and front top knife according to the needle plate	52
.5.1	Cutting angle of the front top knife	52
.5.2	Cutting position of the front top knife	52
.5.3	Cutting pressure of the front top knife	52
.6	Neutral point of top knife movement	54
.7	Setting top knife at highest point	54
.8	Positioning the rear top knife and hook knife	54
.8.1	Lateral position of the rear top knife to hook knife	54
.8.2	Cutting angle of the rear top knife in relation to the hook knife	56
.8.3	Cutting pressure between rear top knife and hook knife	56
.8.4	Setting the cutting depth of the rear top knife in relation to the hook knife	58
.9	Setting the cutting depth of the front top knife	58
.10	Setting the trimming margin	58
.11	Basic adjustments on the top knife mounting	60
.11.1	Cutting angle of the rear top knife	60
.12	Sensor controlled monitoring of the hook knife	62
.12.1	Function	62
.12.2	Sensor adjustment	62
.12.3	Fault finding and remedy	64
51	Airblast for ply separation	66
52	Airblast for cutting waste	66
53	Differential quick adjusting device for altering the fullness	68
.1	Zeroing the rapid differential adjustment	68
.1.1	Rough adjustment on the angle encoder	68
.1.2	Precise adjustment on pot "0"	68
.2	Key arrangement to set pointer 1	70
.2.1	Key "0" and "1 to 4"	70
.2.2	Keys "5 to 7"	70
.3	Basic setting of the fullness quantities of keys "1 to 7"	70
.3.1	Adjustment of fullness key "1"	70
.3.2	Adjustment of fullness key "2"	70
.4	Feed lever	72
.5	Sample adjustment of the potentiometer	74
54	Care and maintenance	76
.1	Sewing machine	76
.1.1	Oiling the sewing machine	76
.1.2	Cleaning the sewing machine	76
.2	Air filter/lubricator	76
.2.1	Water drop bowl	76
.2.2	Air filter	76
.3	Recommended lubricants	77

only on 3822-1/22

only on 3822-1/24

Purpose of application

PFAFF 3822-1/22

Integrated sewing unit for run-stitching and edge trimming.

PFAFF 3822-1/24

Integrated sewing unit for run-stitching and feathered edge trimming.

1 Specifications of the PFAFF 3822-1/22 PFAFF 3822-1/24

Sewing machine head :	for-1/22 487-706/81-731/12-900/51-911/15-910/05-917/.. BSx5 for-1/24 487-706/81-731/12-900/51-911/15-910/05-917.. BSx3,5x6,5
Stitch type :	301
Maximum sewing speed :	for-1/22 4000 s.p.m for-1/24 3000 s.p.m
Maximum stitch length :	for-1/22 5 mm for-1/24 6,5x3,5 mm
Needle system :	134 KK
Needle size :	80
Trimming margin :	5,0 mm on PFAFF 3822-1/22 6,5 x 3,5 mm on PFAFF 3822-1/24
Fabric clearance :	7 mm
Sewing motor :	for-1/22 Quick digital QD 552 P40 K2 for-1/24 Quick digital QE 5542 Q40 SE
Power input :	1,2 kW
Connection voltage :	E 230 Volt, 50 / 60 Hz
Working pressure :	6 bar
Air consumption :	~40 standard litres
Workplace-related noise :	at sewing speed n=2400 r.p.m: $L_{PA} \leq 75$ dB(A) Noise measurement according to DIN 45635-48-A-1.
Dimensions of unit :	Length : 1365 mm Breadth : 950 mm Height : 1700 mm (with reel stand)
Weight :	Net : 140 kg

2 Controls and indicators

General view

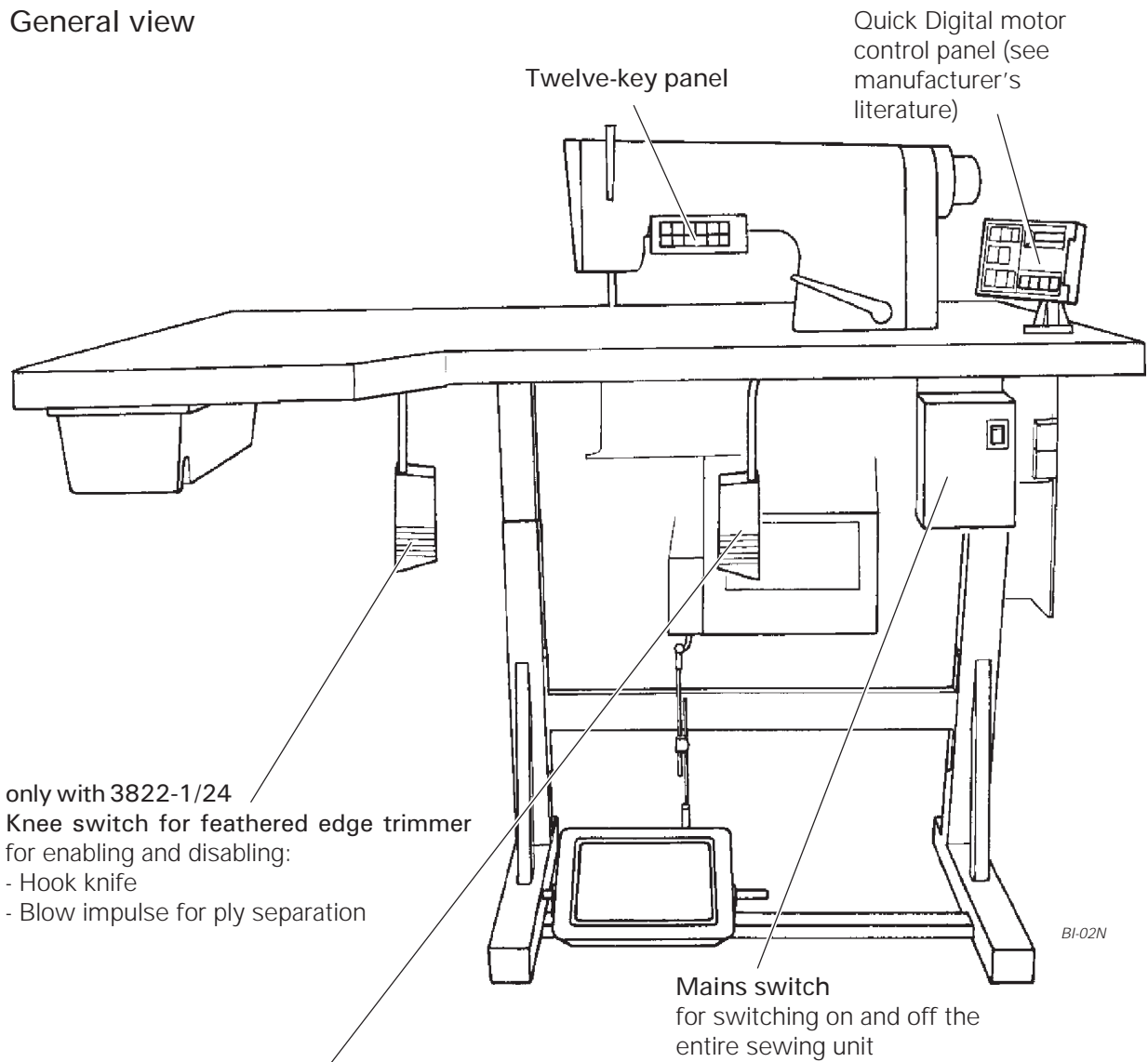

Knee switch for fullness
By operating the knee switch it is possible to switch between the last gather amount that was inputted on the twelve-key keypad and sewing without fullness

Pedal functions

0 = Neutral pedal position

+ = Pedal forwards

+1 = Presser foot down

+2 = Sewing (and when edge trimmer is engaged: suction and sewing)

- = Pedal backwards

-1 = Backtack and raise presser foot

-2 = Thread trim

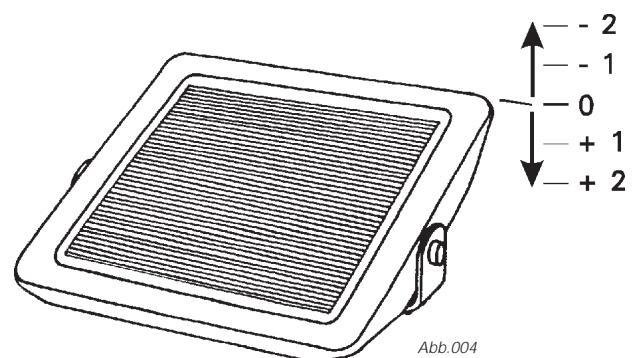

Twelve-key keypad (functions are enabled when LED is on)

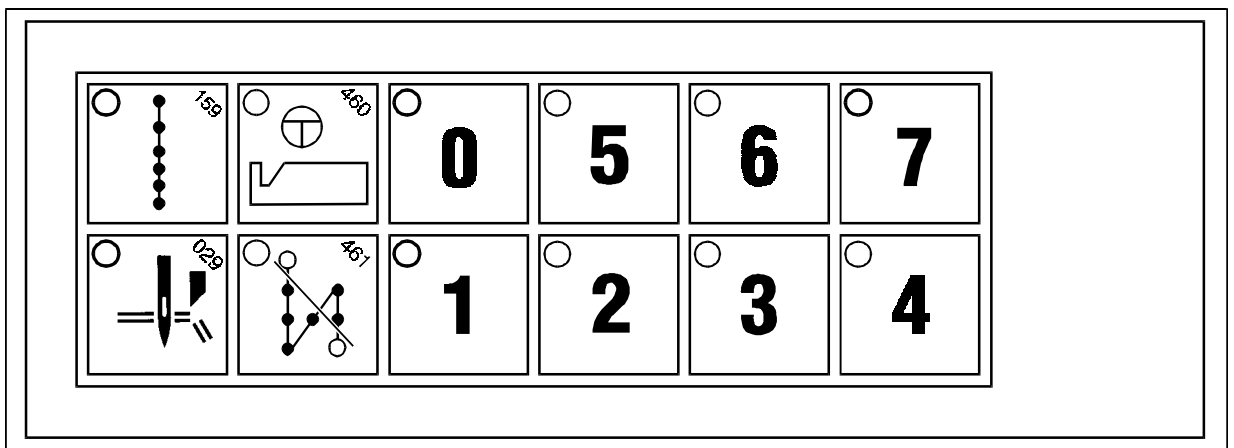

	Stitch concentration on / off
	Edge trimming on / off
	Key for feathered edge trimmer, (also knee switch for feathered edge trimmer on page 6) for enabling and disabling: - the hook knife - the blow impulse for ply separation Key has no function in 3822-1/22
	Backtick switch-off; the machine sews a backtick, according to the setting on the motor control panel (see motor manufacturer's documentation), at the beginning and at the end of the seam. The backtick can be avoided by briefly touching the push-button before actuating the treadle forwards or backwards, respectively. If no backtick is enabled, it is nevertheless possible to recall the next backtick with this key.
	Fullness "0" (no fullness; shift-free sewing) =====
to	Fullness is applied to the bottom ply.
to	Fullness is applied to the top ply.

3 Examination before commissioning

After the machine is unpacked and before commissioning it must be examined for damage in transit.

In cases of damage, be sure to inform both the forwarding agent and the PFAFF agency responsible.

4 Setting up the machine

Set up the machine horizontally at its intended location



On newly commissioned machines or on machines which have not been used for a long time be sure to check the hook oil supply (see chapter 8.4).

5 Compressed air and electrical connection

5.1 Compressed air

Connect compressed-air hose (internal dia. of 6 mm) to coupling (Fig. 1).

Minimum supply pressure: 7 bar

Working pressure: 6 bar

Pressure adjustment: regulating knob 2

5.2 Electrical

.1 Permissible operating power is indicated on spec. plate (Fig. 2).

Note: The operating voltage indicated on the specification plate refers to the control.
It is not necessarily applicable to the entire system!

.2 Connection must only be made if mains and operating voltage coincide.

.3 The machine must only be connected to a suitable earthed socket.

6 Switching the machine on

.1 Open compressed air supply.

.2 Check working pressure: 6 bar (gauge 3, Fig. 1)

.3 Re-adjust if necessary (regulating knob 2).

.4 Switch on machine (rotary switch 4 to "ON", Fig. 3)

7 Switching the machine off

Set tumbler switch 4 at "0" (fig. 3).

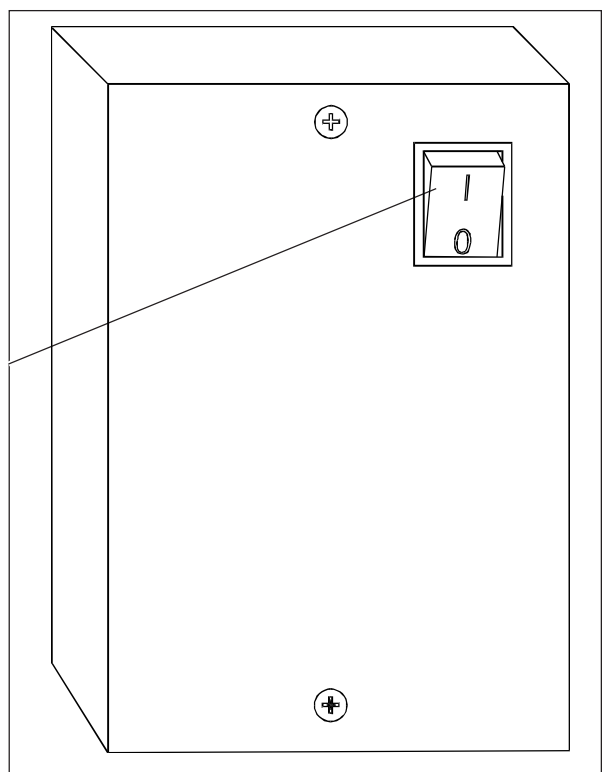
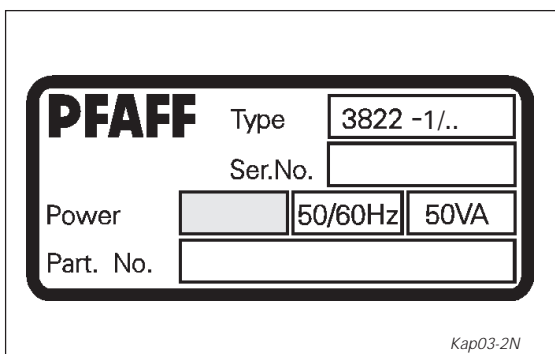
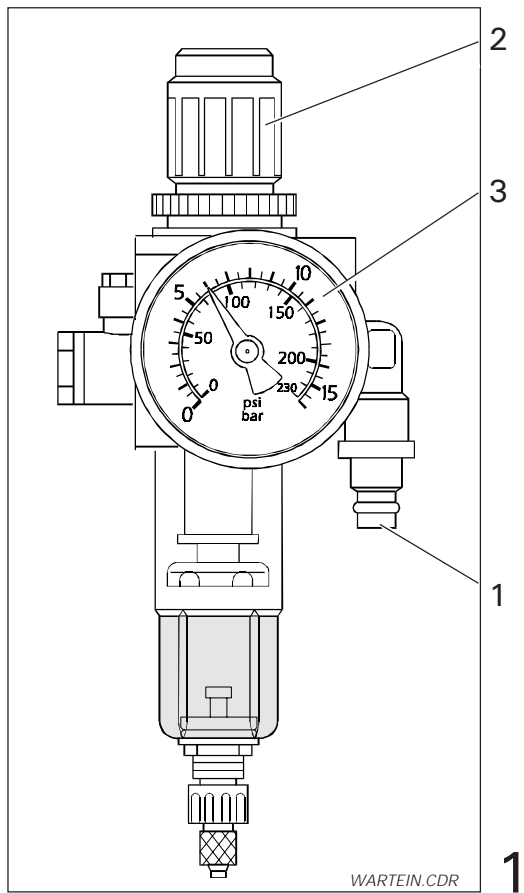

8 Checks

8.1 Oil level of sewing machine

.1 Tilt sewing head over backwards.

.2  Before putting machine into operation for the first time, remove cork from hole 1 by all means (fig. 1).

.3 If necessary, top up oil in oil bowl 2 to the upper mark 3.

Note: Afterwards it will be necessary to top up oil in oil bowl 2 once a month, if machine is used 8 hours a day.

Only use oil with a mean viscosity of 10.0 mm²/s at 40°C and a density of 0.847 g/cm³ at 15°C. We recommend Pfaff sewing machine oil, parts no. 280-1-120 105.

.4  Lift sewing head back into position with both hands. Risk of crushing between sewing head and table top.

8.2 Rotating direction

Requirement: The balance wheel must rotate as shown by the arrow (Fig. 3)

.1 Switch on machine.

.2 Raise presser foot using presser bar lifter.

.3 Press pedal lightly forwards.

.4 If rotating direction is incorrect, see motor manufacturer's literature, parameter 800.

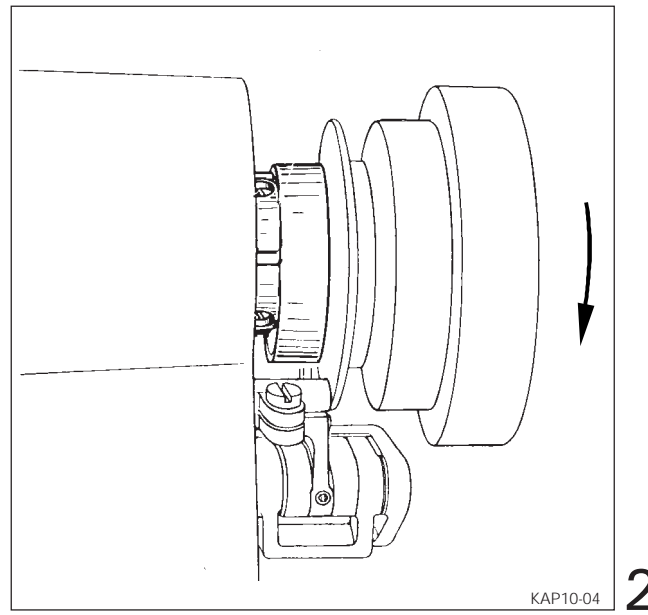
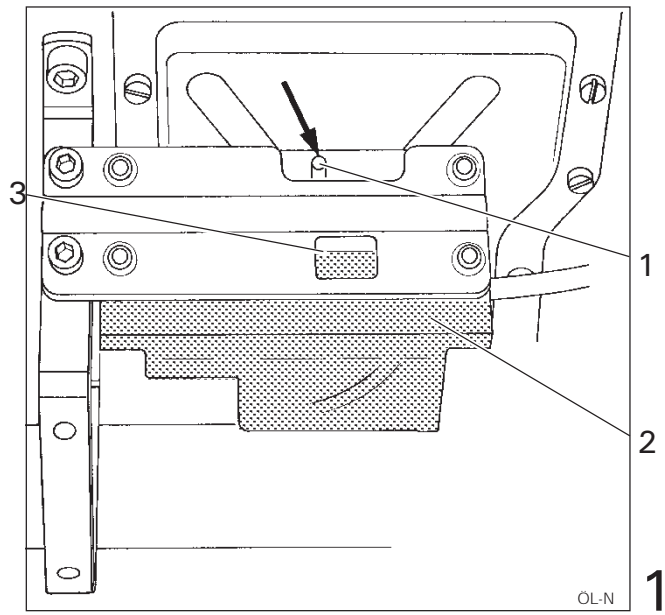

9 Inserting the needle

Needle system 134 KK



Switch off machine!

10 Winding the bobbin thread

- .1 Place a bobbin on winder spindle 1 (Fig. 1).
- .2 Press winder spindle 1 inwards
- Winder is engaged
- .3 Thread up as shown in Fig. 2 and wind thread a few turns around bobbin.
- .4 Bobbin is filled during sewing.
- .5 To regulate the amount of thread: pin 2 (screw 3)

Note: If bobbin is wound unevenly, position thread guide 4 according (nut 5) and regulate winding tension (chapter 11).

11 Regulating the winding thread tension

Knurled washer 6 (Fig. 2)

- + = increase
- = decrease

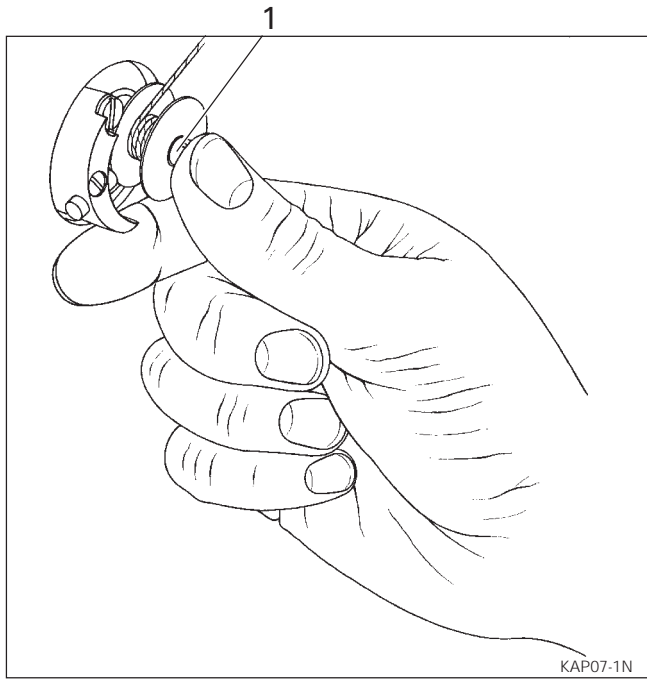

1

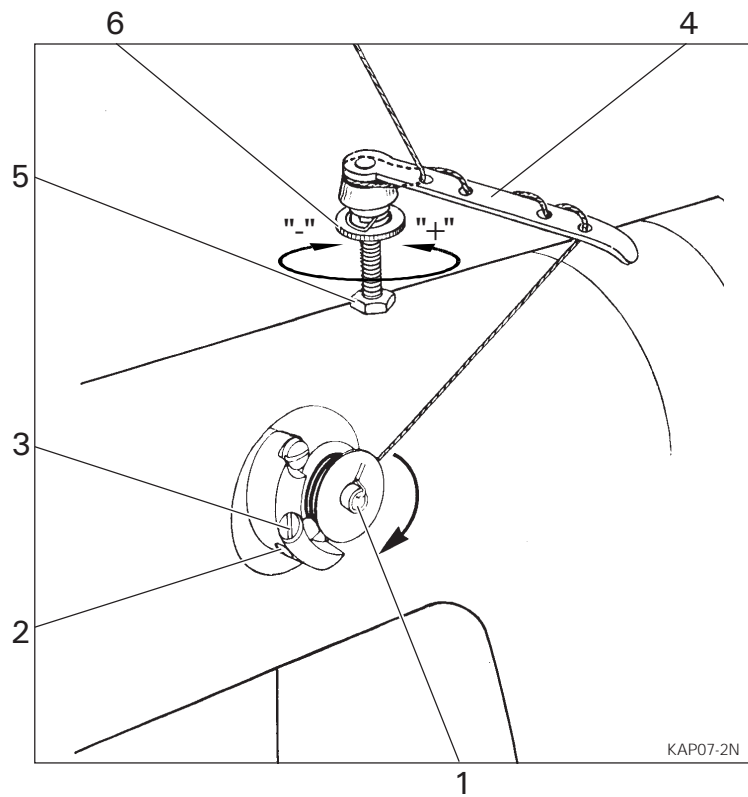

2

12 Removing the bobbin case

.1  Switch off machine!

.2 Set take-up lever at t.d.c. position (balance wheel)

.3 Open latch 1 (Fig. 1) and take out bobbin case

13 Threading the bobbin thread

.1 Insert bobbin in bobbin case so that it turns as shown by arrow when thread is pulled (Fig. 2)

.2 Hold bobbin, pull thread through slot 2 and under tension spring 3.

14 Regulating the bobbin thread tension

Screw 4

+ = increase

- = decrease

15 Inserting the bobbin case

.1 Open latch 1 (Fig. 1).

.2 Insert bobbin case in hook and release latch 1 (must audibly snap in).

.3 Press bobbin lightly case to make sure it has snapped in properly.

16 Threading the needle thread



Switch off machine!

17 Adjusting the needle thread tension

Knruled nut 5 (Fig. 3)

+ = increase

+ = decrease

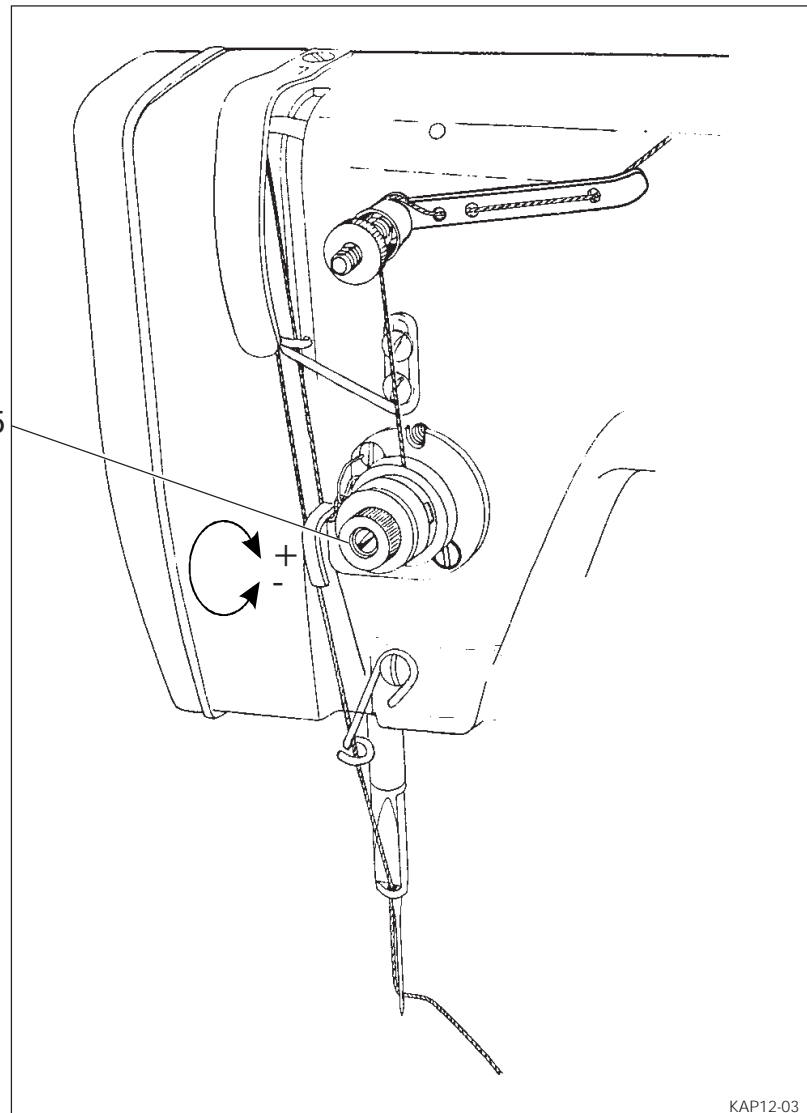
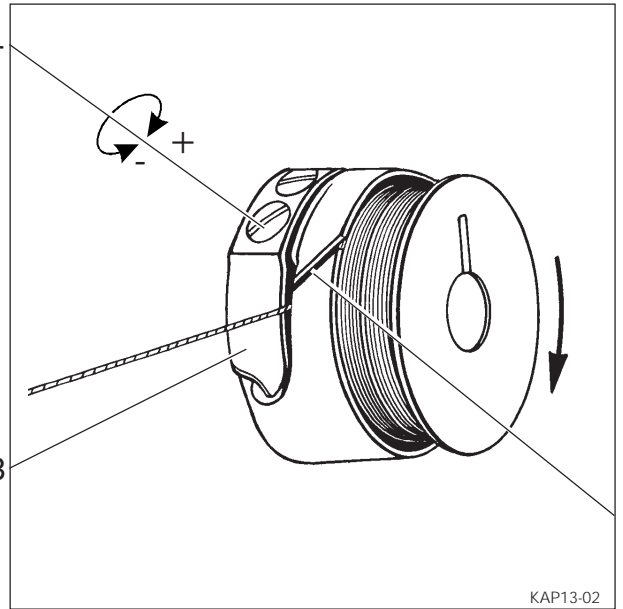
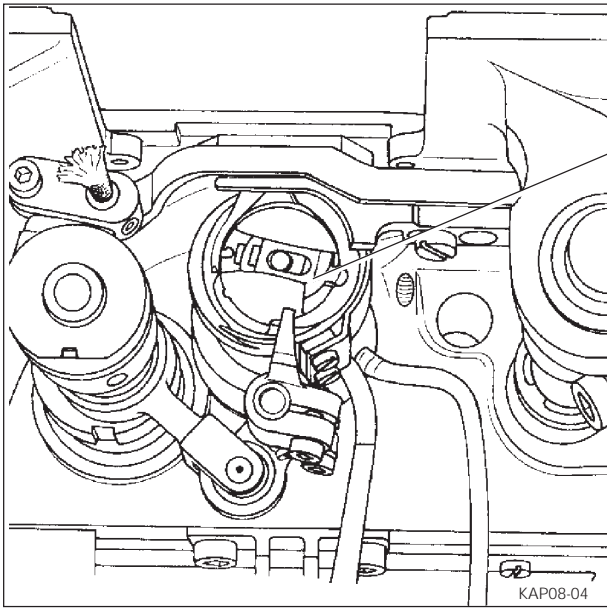

18 Checking and adjusting aid

Requirement: The machine can be blocked at adjustment holes 1 to 6, in order to allow accurate fixing of the required needle bar positions.

- .1 Turn balance wheel until needle bar is roughly at required position.
- .2 Insert (5 mm) adjustment pin in hole for required adjustment and press against pin.
- .3 Turn balance wheel back and forth a little until pin enters the hole in the crank behind the bearing plate and blocks the machine.

19 Needle to needle hole

Requirement: A perfectly straight needle must enter exactly in the centre of needle hole (Fig. 2, for needle system see "Specifications").

- .1 Loosen screws 2, 3 and 4 (Fig. 3)
- .2 Adjust needle bar frame 5 accordingly.
- .3 Firmly tighten screw 2.
- .4 Using screw 2, pull the guide pin behind it against the eye of needle bar frame 5.
- .5 Tighten screw 3, then screw 2.
- .6 Loosen screw 3, turn the balance wheel a few times (to remove any binding), then tighten screw 3 again.

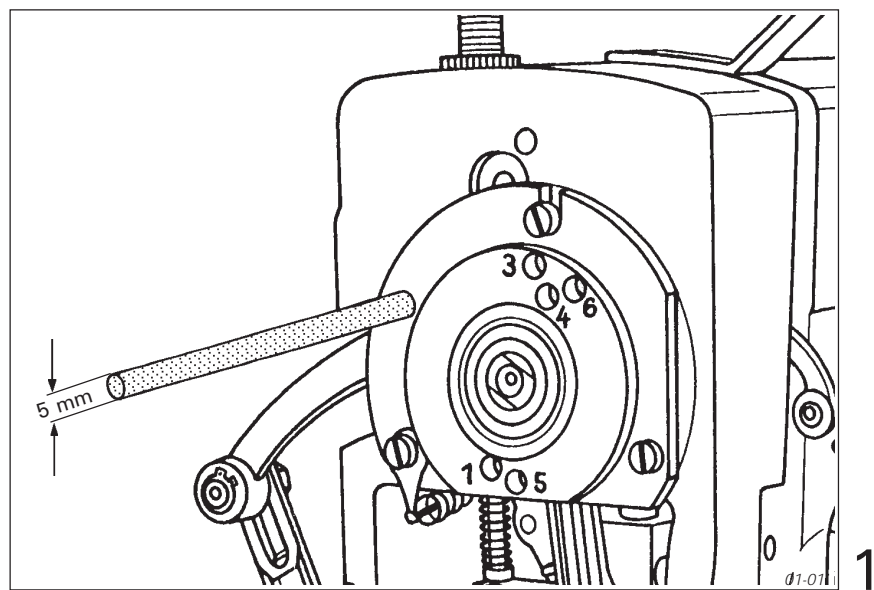

1

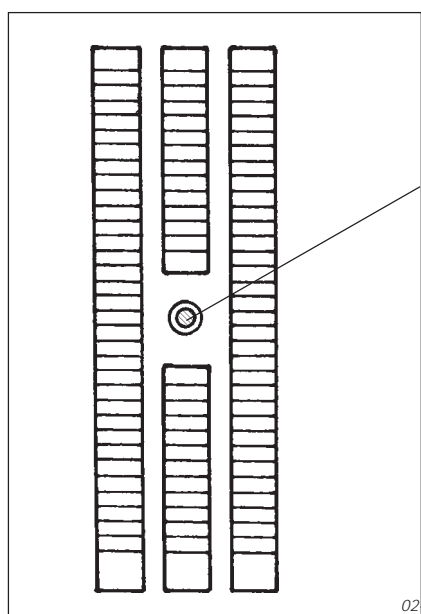

1

2

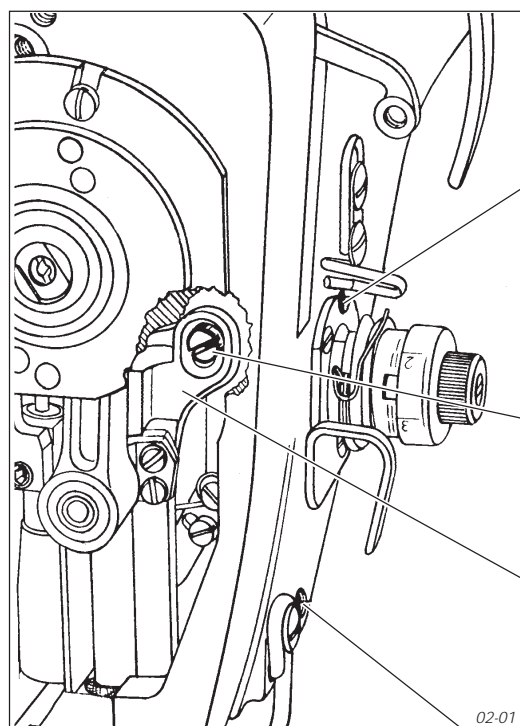

3

2

5

3

4

20 Neutral position of bottom feed dog

Requirement: At stitch length "0" the bottom feed dog must not make any feeding movement.

- .1 Set stitch length at "0" (lever 1, Fig. 1)
- .2 Set mark of eccentric bush 2 at 45° position (screw 3).
- .3 Adjust feed regulator crank 4 (Fig. 3, screw 5).

21 Stitch length limitation

- .1 Loosen and take out screw 6 (Fig. 4), accessible through fitting hole, and insert screw at different setting.
- .2 Set maximum stitch length of 3 mm (lever 1)
- .3 Place limitation stop 7 from top onto adjusting lever 1 and tighten it (screw 6).

22 Bottom feed actuating lever

Requirement: When the longest stitch length is set, reverse-feed lever 8 (Fig. 5) must have a slight play (0.3 to 0.5 mm) when operated.

- .1 Set longest stitch length (3 mm).
- .2 Press reverse-feed lever 8 onto stop 9.
- .3 Press actuating lever 10 lightly against reverse-feed lever 8 (screw 11).

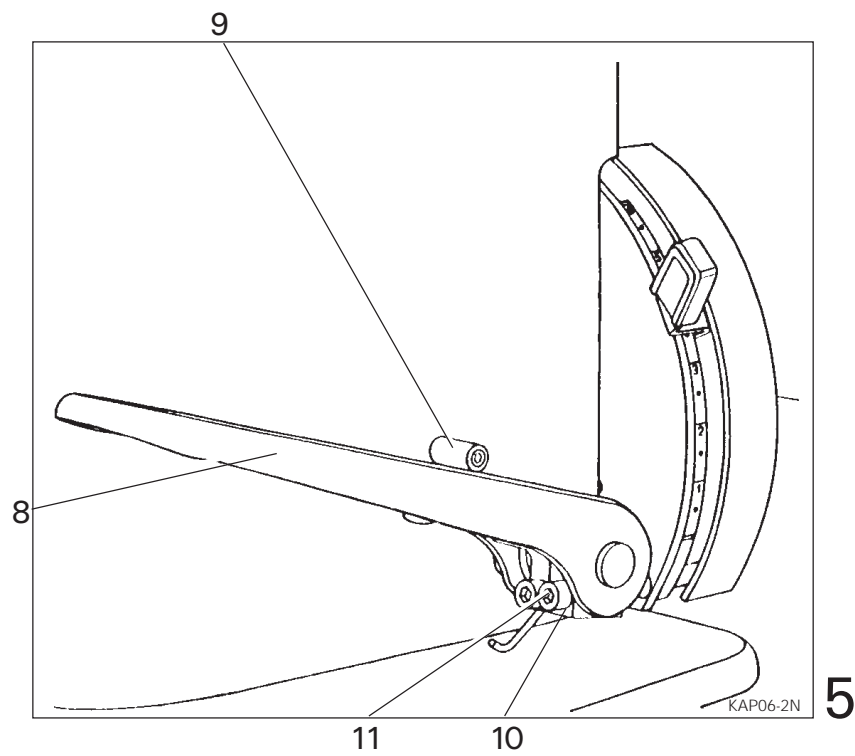
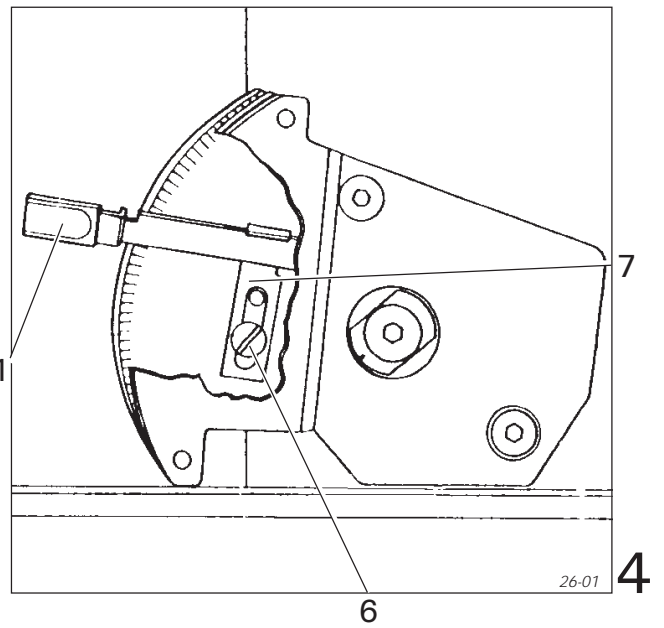
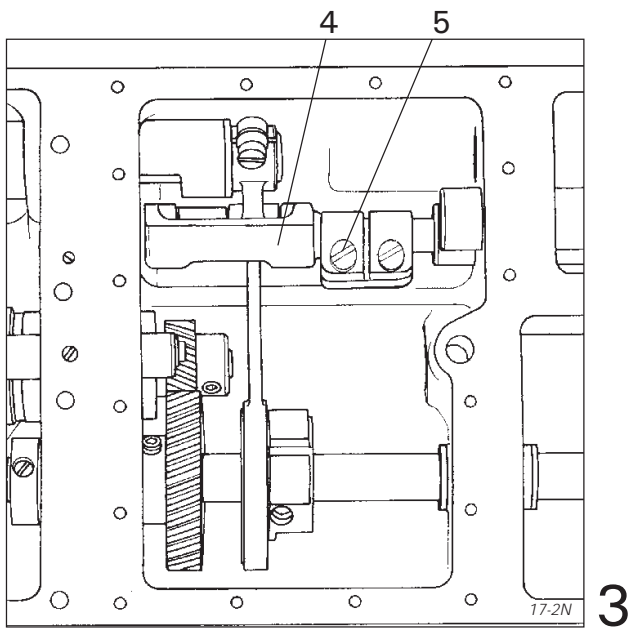
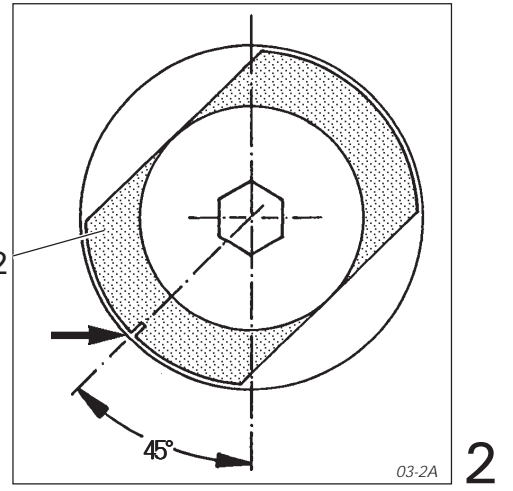
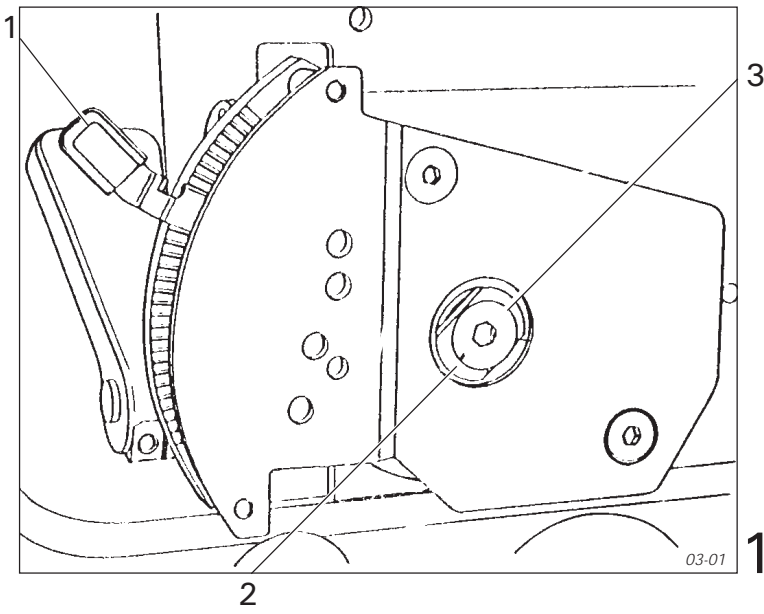

23 Bottom feed dog stroke

Requirement: When the longest stitch length is set and the needle bar is set 0.6 mm past top dead centre (adjustment hole "1", Fig. 1) the bottom feed dog must not make any driving motion when the reverse-feed lever is pressed.

Adjust eccentric 2 (screws 3).

24 Bottom feed lifting motion

Requirement: When the stitch length is set at "0" and the needle bar is set 0.6 mm past top dead centre (adjustment hole "1", Fig. 1) the bottom feed dog must be at the top of its stroke (the cutout in eccentric 4, Fig. 3, is facing vertically downwards).

Adjust eccentric 4 (screws 5).

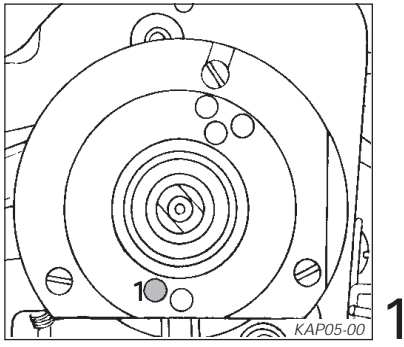

1

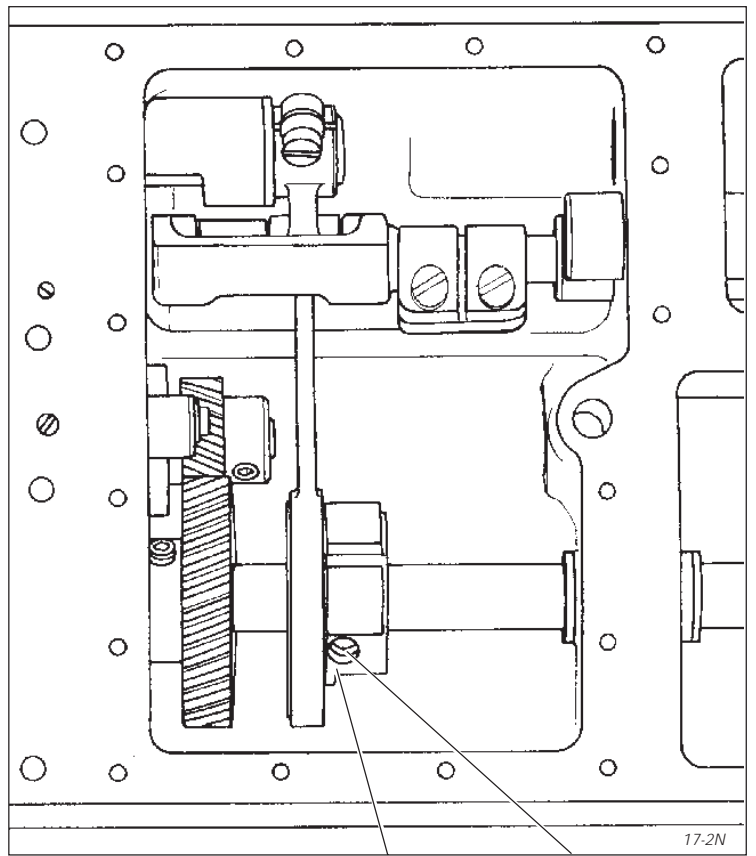

2

2

3 (2x)

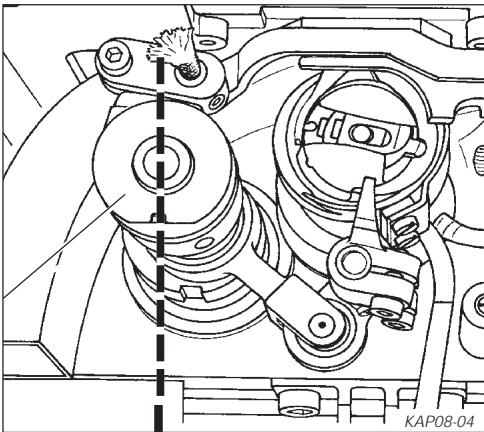

3

4

KAP08-04

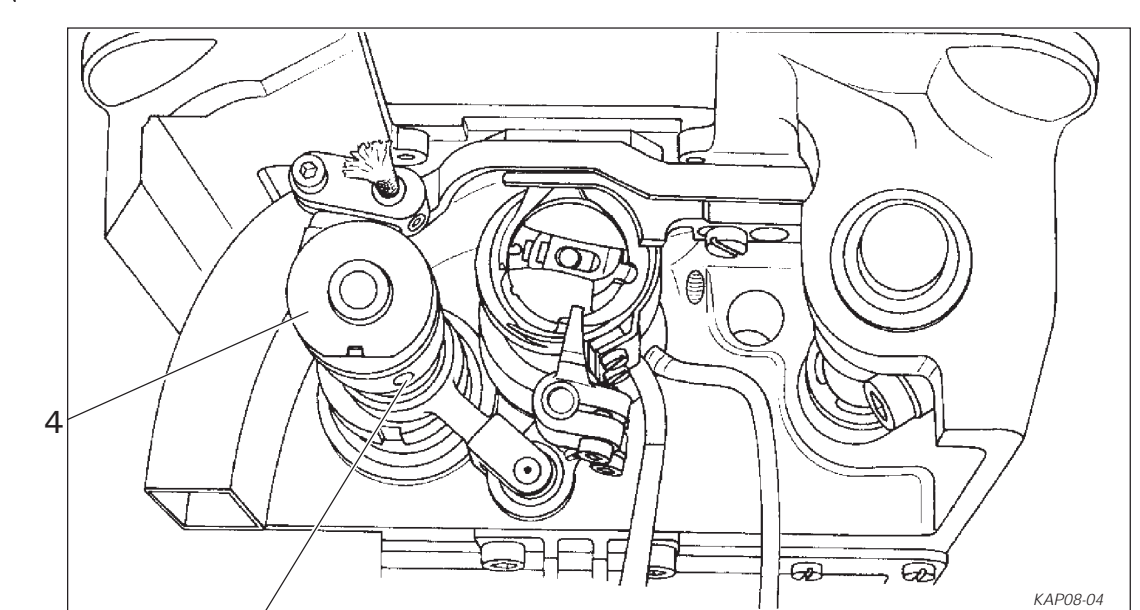

4

4

5 (2x)

KAP08-04

25 Bottom feed dog height

Requirement: When the stitch length is set at "0" and the needle bar is set 0.6 mm past top dead centre (adjustment hole "1", Fig. 1) the bottom feed dog must be centred in the feed slots and touch the adjustment gauge throughout its length (Fig. 2).

Height adjustment, rear: screw 1 (Fig. 3)
front: eccentric sleeve 2 (screw 3).

26 Spacing between presser foot and needle plate

Requirement: Spacing with lifted hand lever = 7 mm.

- .1 Insert gauge (fig. 5) between presser foot and needle plate (hand lever is lifted).
- .2 Bring lifting piece 4 (fig. 6) in contact with presser bar lifting lever 5 (screw 6).

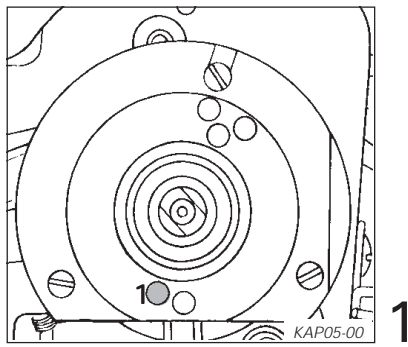

1

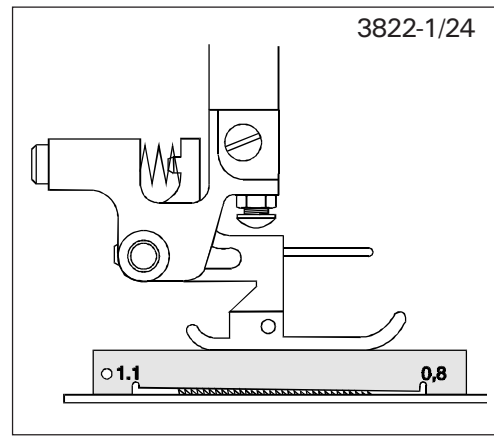

2

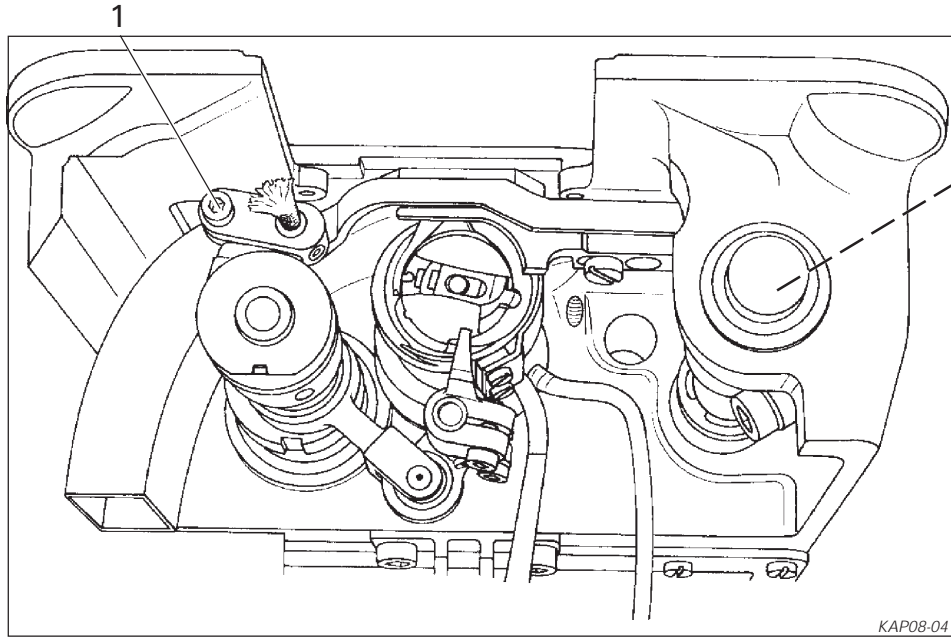

3

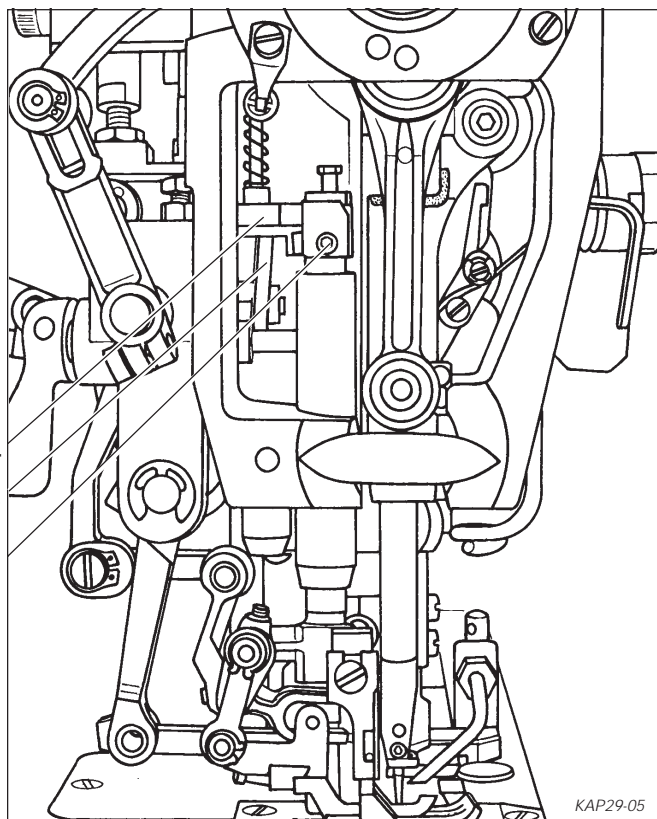
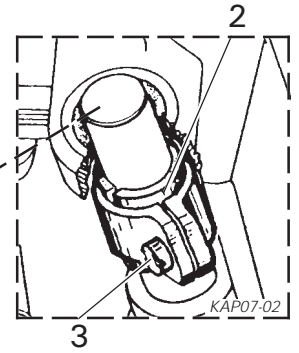

4

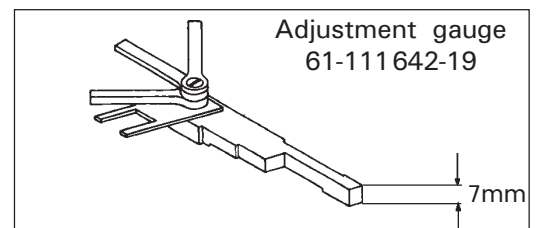

5

27 Adjusting the floating foot

27.1 on 3822-1/24

27.1.1 Height adjustment

Requirement: With the gauge foot resting on the needle plate, screw 1 (fig. 2) must be in contact with the stop.

- .1 Lift floating foot (fig. 3) by means of hand lever 2.
- .2 Unscrew floating foot.
- .3 Screw on gauge foot (fig. 1).
- .4 Bring down gauge foot by means of hand lever 2 so that it rests on needle plate.
- .5 Turn screw 1 so that it touches the stop when gauge foot is resting on the needle plate.
- .6 Unscrew gauge foot and screw on floating foot.

27.1.2 Distance screw

Requirement: Screw 3 (fig. 3) must be turned in to such an amount that the bottom part of the floating foot (see arrow) touches the head of the screw only when the presser foot is lifted by more than the sum of the feed dog height and the workpiece thickness (approx. 0,5 mm).

Adjustment: Screw 3.

27.2 on 3822-1/22

27.2.1 Height adjustment

Requirement: With the bottom feed dog positioned below the top edge of the needle plate (fig. 4) there must be a spacing of 0.5 mm between stop 5 and guide 6.

Adjustment: Screw 1 (fig. 2).

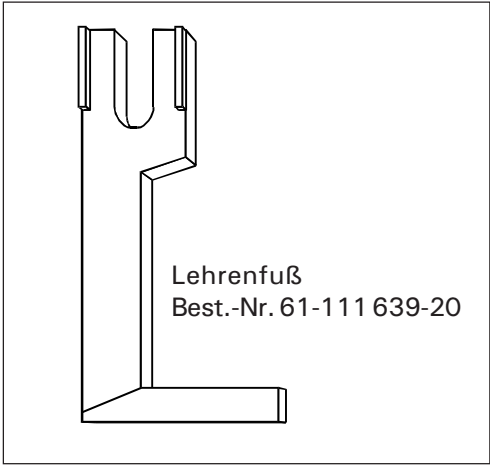

1

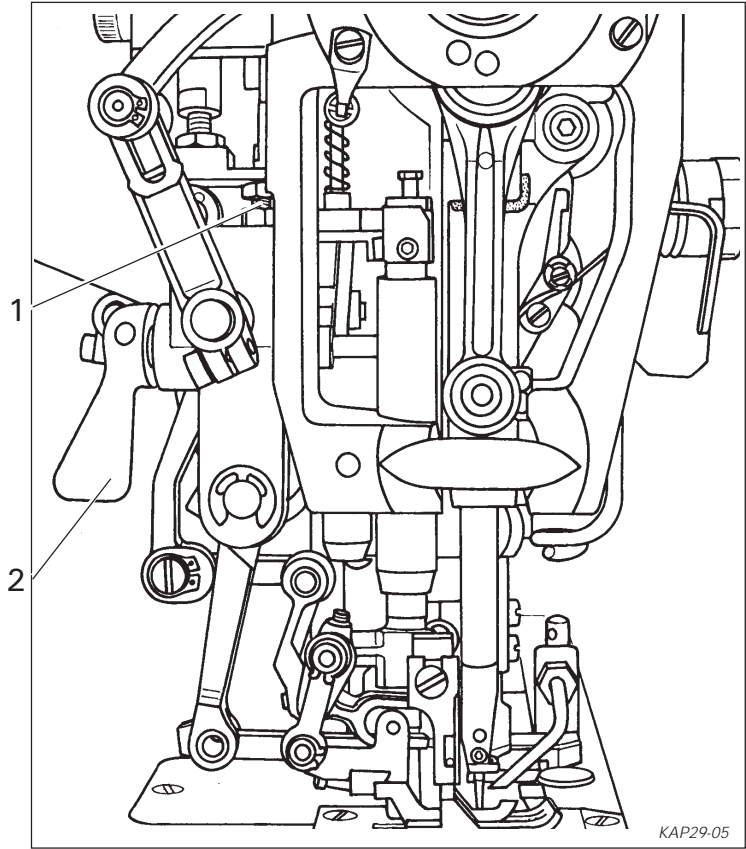

2

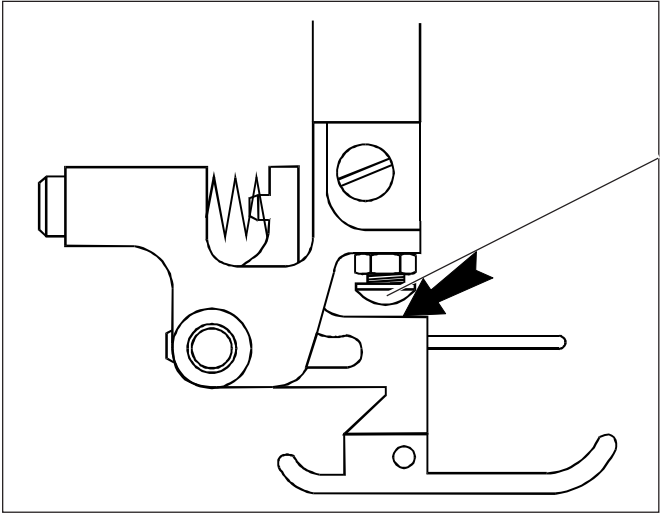

3

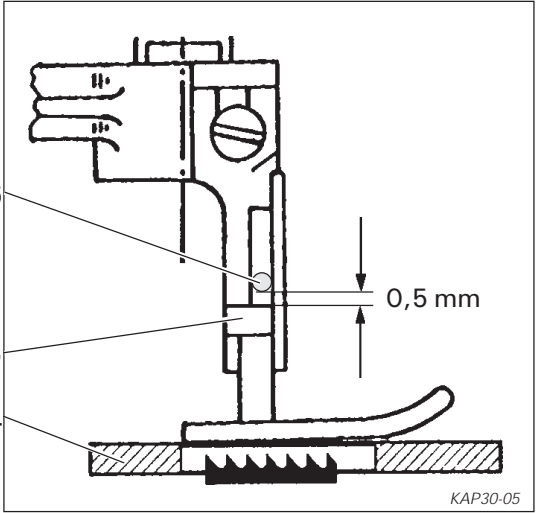

4

28 Top feed driving link

Requirement: All moving parts of the top feed must move freely but without play.

- .1 To check free movement, take out pin 1 (screw 2) and eccentric pin 3 (screw 4, Fig. 1).
- .2 It must be possible to push pins 1 and 3 in easily.
- .3 If necessary, bend drive levers 5 and 6 to shape accordingly.

29 Top feed neutral position

Requirement: When the stitch length is set at "0" (top and bottom feed) and adjustment link 7 (Fig.2) is fitted, the top feed must not make any feeding movement.

- .1 Set feed regulator lever 8 (Fig. 3) at "0"
- .2 Set lever 9 (Fig.3) parallel with lever 10 (screw 11)
- .3 Place adjusting link 7 onto pins 12 (Fig. 2).
- .4 Set crank 13 (screw 14) so that feeding foot does not make any feeding motion (Fig. 4).
- .5 Adjust lever 15 (Fig. 1) (screw 16, Fig. 5) so that top feed foot does not make any feeding motion when connecting rod 17 (nut 18, Fig 1) is moved up and down in the elongated hole.
- .6 Push connecting rod 17 (nut 18) fully upwards.
- .7 Take off adjusting link 7 (Fig. 2)
- .8 Press feed regulator lever 8 (Fig. 3) fully upwards.
- .9 Set actuating levers 19 and 20 (Fig. 3) at a clearance of 0,5mm on reverse-feed lever 21 (screws 22)
- .10 Press connecting rod 17 (Fig. 1) fully downwards (nut 18).

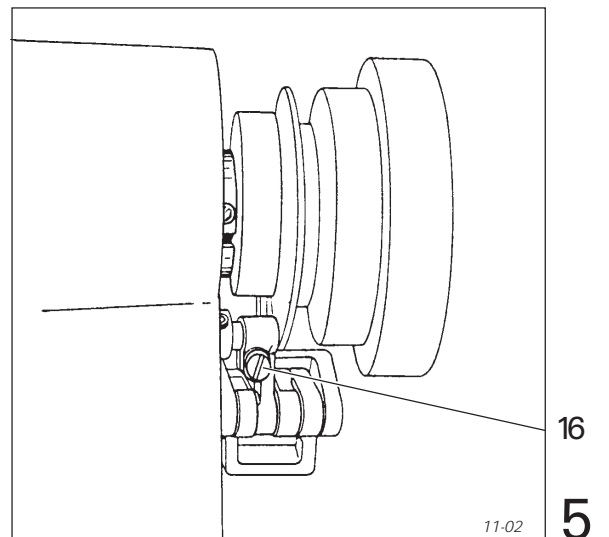
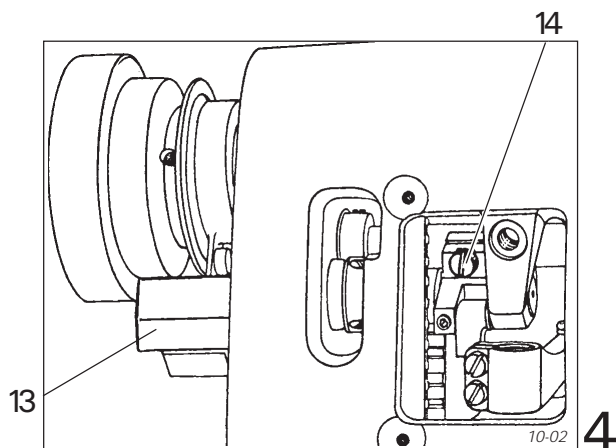
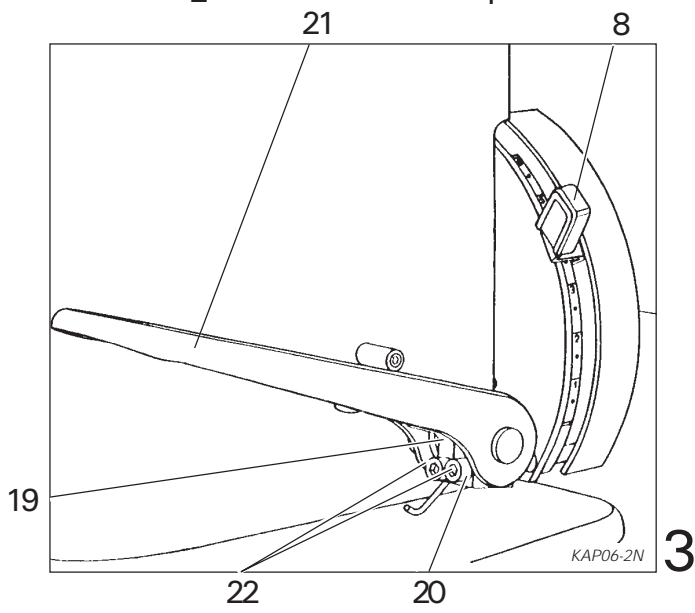
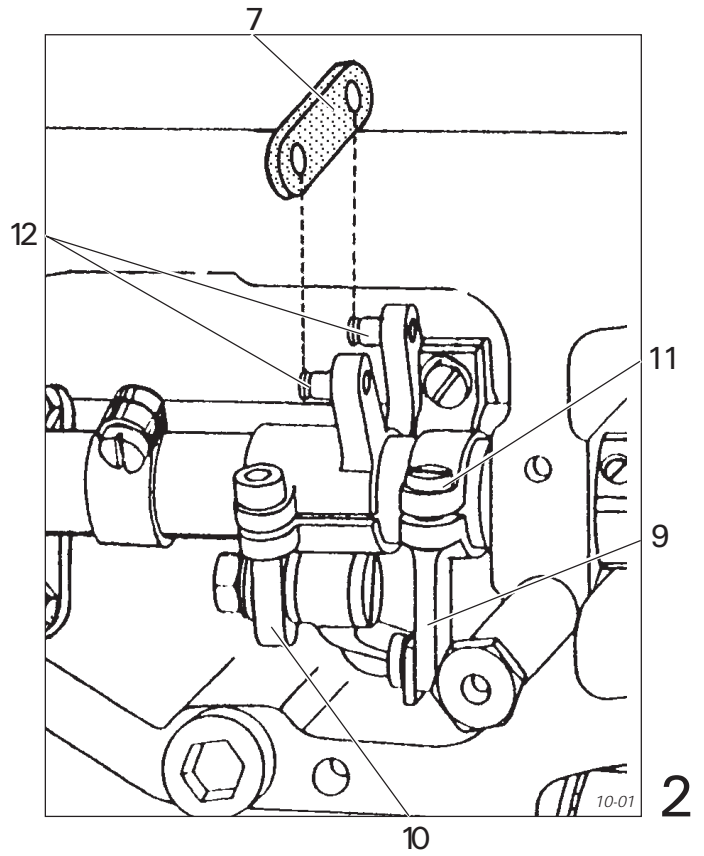
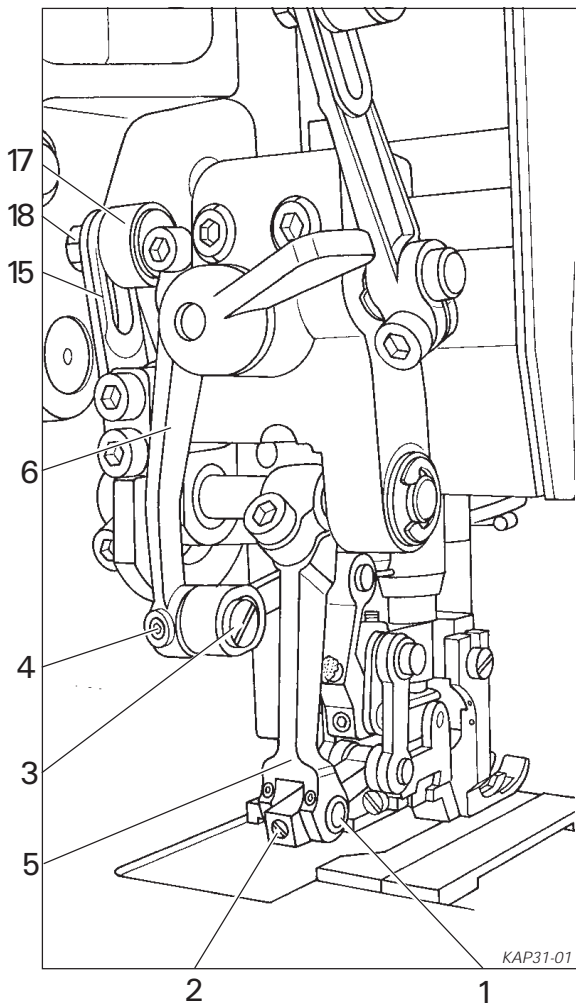

30 Top feed driving motion

Requirement: When the longest stitch length is set and the needle bar is set 0.6 mm past top dead centre (adjustment hole " 1 " , Fig. 1) top feed foot 1 (Fig. 2) must not make any feeding movement when the feed regulator is operated.

- .1 Adjust eccentric 2 (Fig. 3, screws 3).
- .2 The slot in eccentric 2 (see arrow) must face forwards.

31 Top feed stroke

Requirement: The greatest clearance between top feed foot and needle plate when
- the stitch length is at " 0 " , and
- the presser foot is resting on the needle plate (Fig. 4)
- (on -706/82 the top feed foot is behind the needle: is 1.3 mm

- .1 Set stitch length at " 0 " and lower presser foot onto needle plate.
- .2 Increase presser foot pressure (knurled screw 4, Fig. 5).
- .3 Basic setting of pin 5: eccentric side facing needle bar (screw 6).
- .4 Basic setting of eccentric pin 7 (Fig. 6): eccentric side facing downwards (screw 8).
- .5 Adjust clearance by shifting lever 9 (screw 10).
- .6 Fine adjustment on eccentric pin 7 (screw 8).

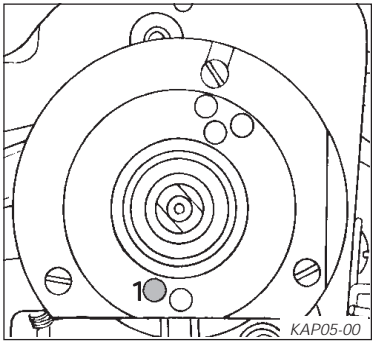

1

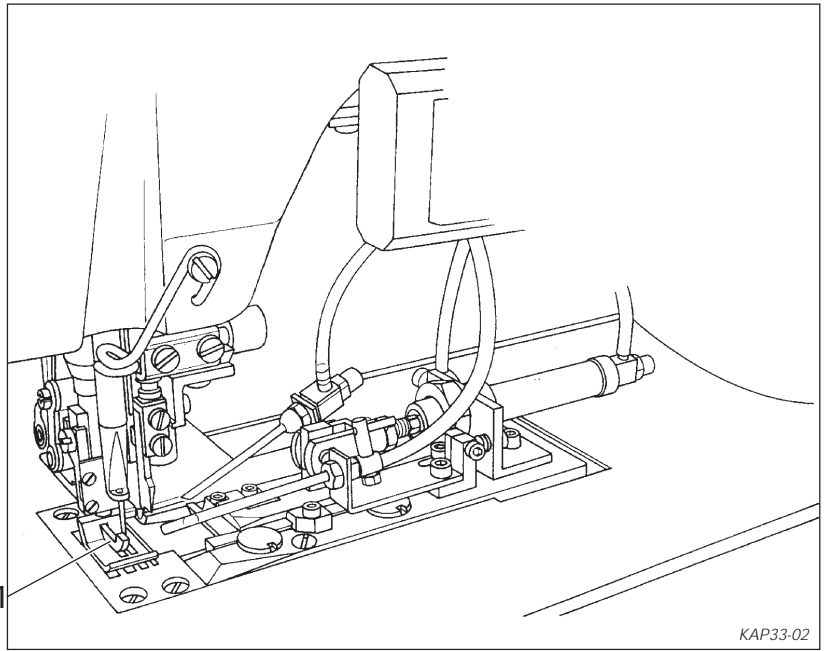

2

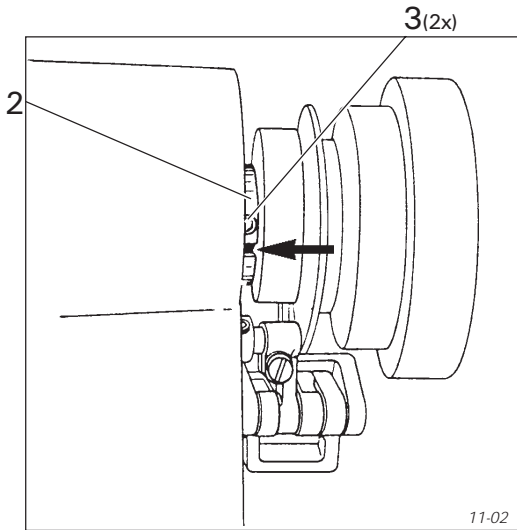

3

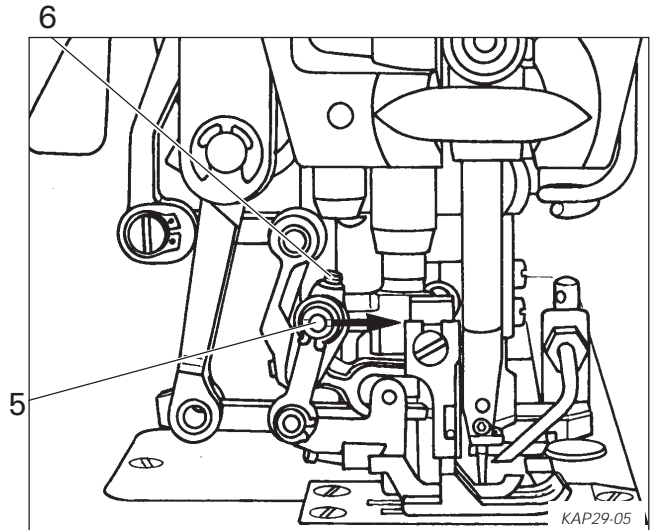

4

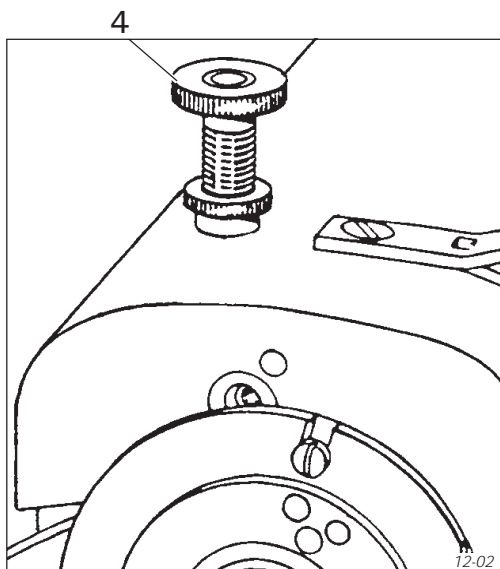

5

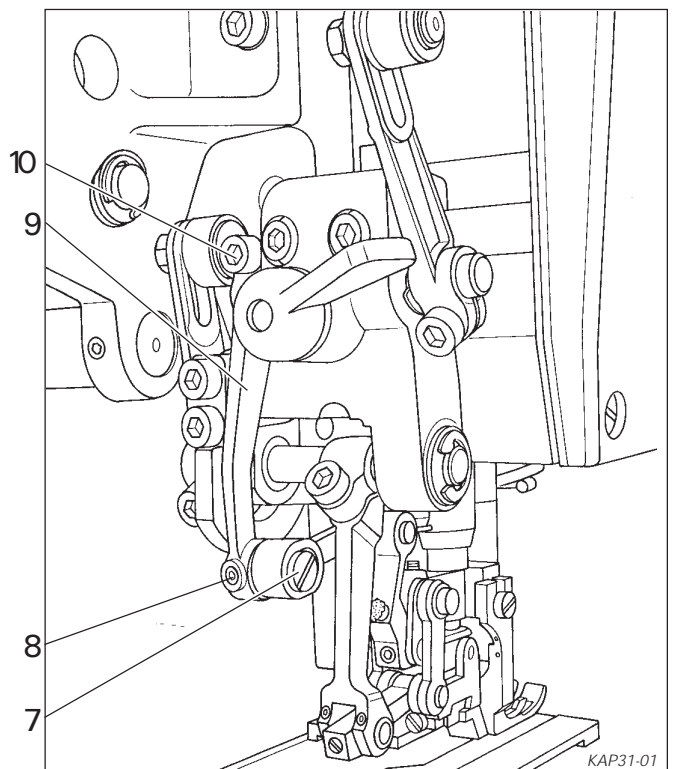

6

32 Top feed lifting motion

Requirement: At stitch length " 2" the top feed foot must rest on the bottom feed dog when the latter has reached the top surface of the needle plate on its upward stroke.

Adjust eccentric 1 (Fig. 1, screw 2).

33 Top feed foot position

Requirement: When the bottom feed dog is at the top of its stroke, the top feed foot must be parallel with the bottom feed dog.

Adjust eccentric pin 3 (Fig. 2, screw 4).

34 Top feed synchronization

Requirement: At stitch length " 3" , both top- and bottom feed motions must be the same length.

- .1 Compensate by shifting pin 5 (Fig. 3) in elongated hole (nut 6).
- .2 Adjustment according to chapter 28 must be checked.

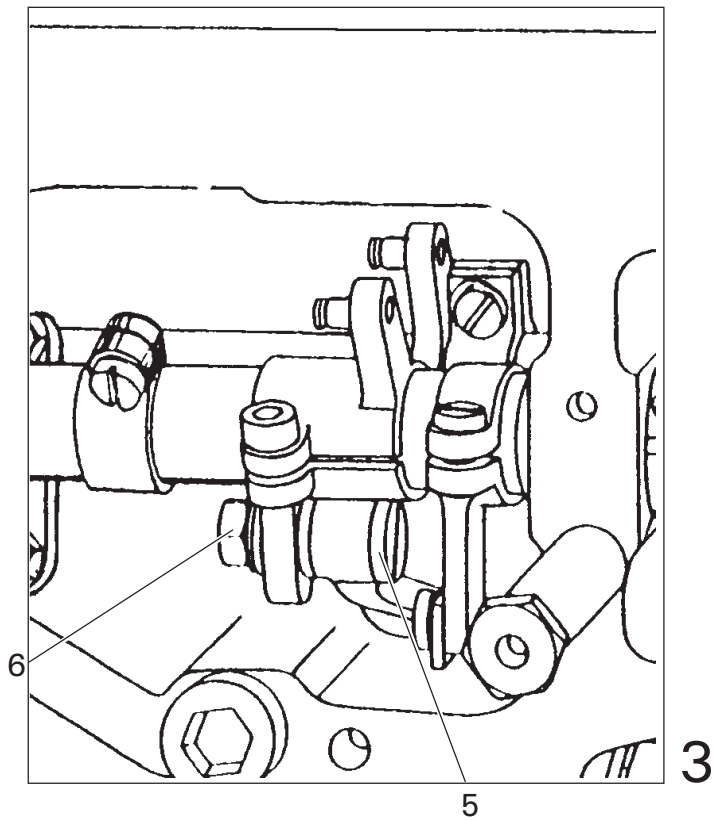
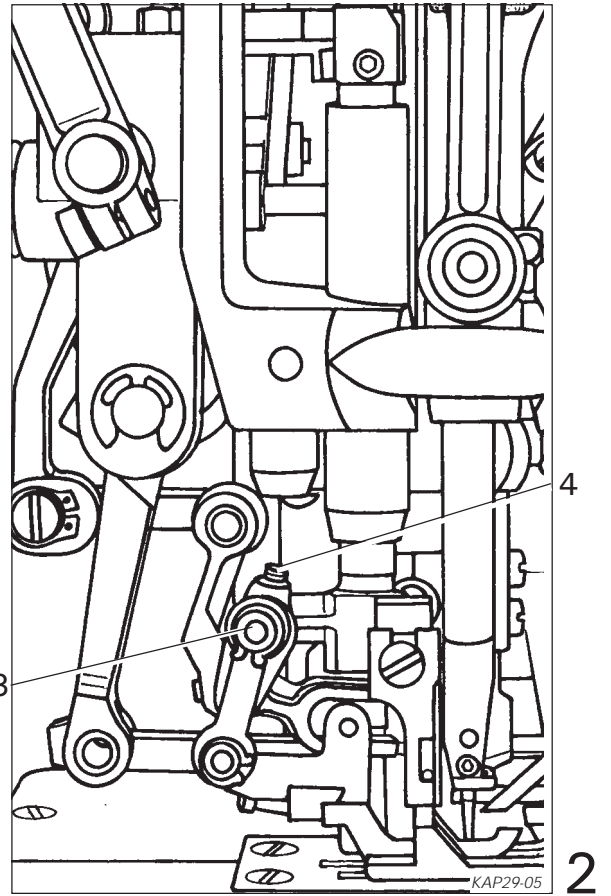
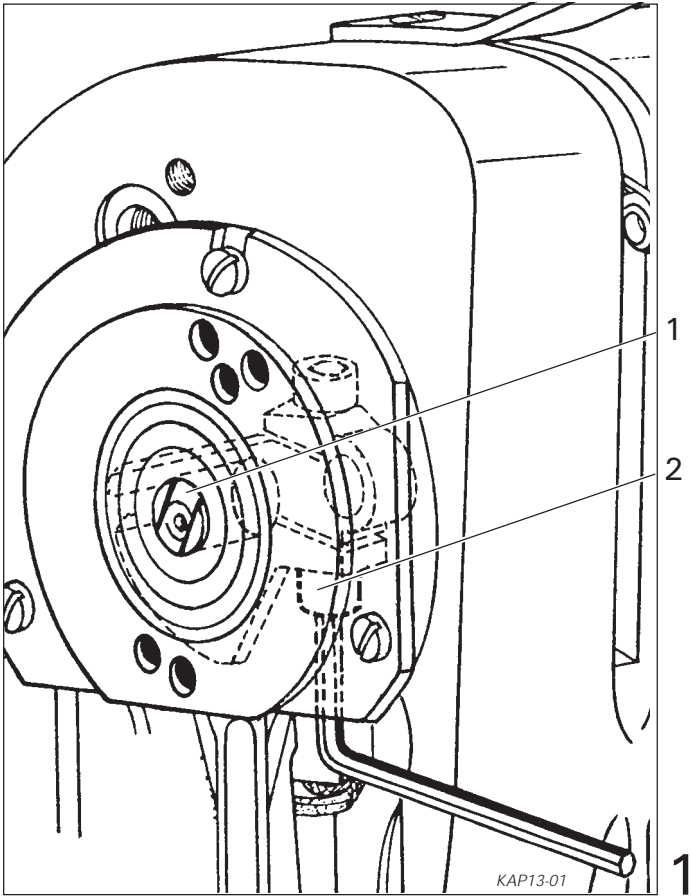

35 Stitch length compensation

Requirement: The stitch length set at "3" must be the same length during forward and reverse feeding.

If high accuracy is required, do not use "3" but the actual working stitch length needed.

Slightly turn bush 1 (Fig.1) from its basic position (screw 2) (see chapter 20).

36 Eccentric hook shaft bearing

Requirement: Clearance between hook point and centre of needle clearance cut must be 0.3 mm when the hook is loosened (screw 3) and is up against the oil ring (Fig. 2).

The backlash between the gear teeth must be only slight but still perceivable.

- .1 Position hook shaft bearing 4 axially (screw 5).
- .2 Turn hook shaft bearing to adjust backlash (screw 5).
- .3 Adjust position of gear 6 (two screws 7).

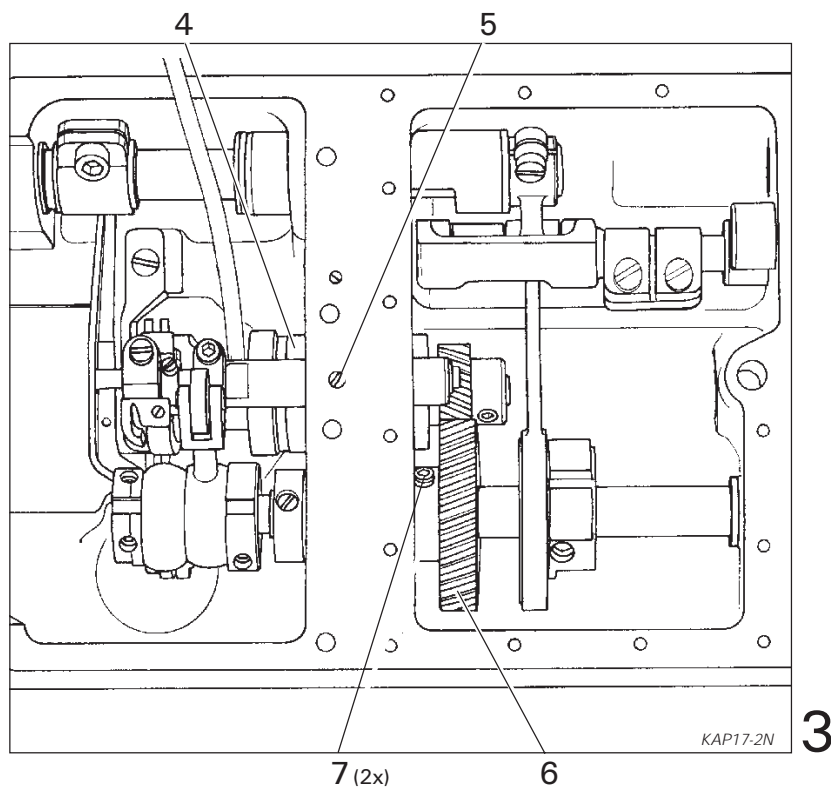
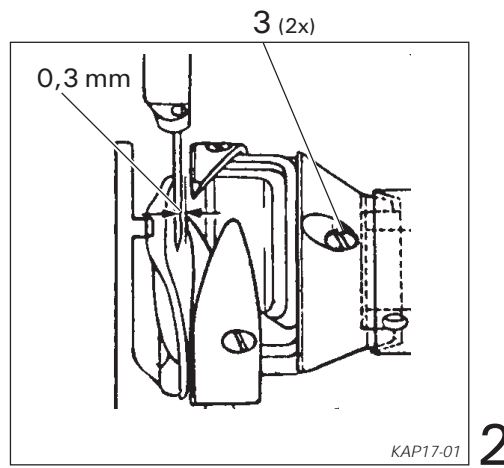
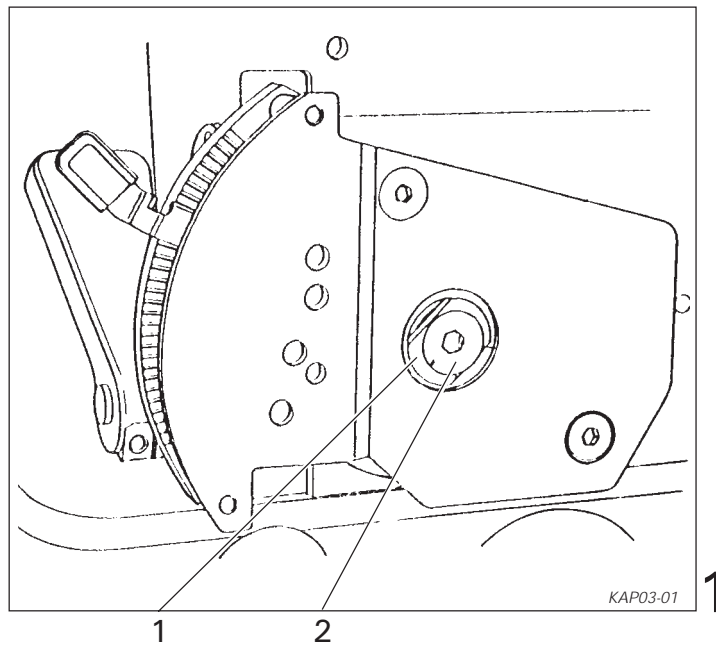

37 Needle height, needle rise and hook clearance

Requirement: In needle bar position 1.8 mm past b.d.c. (= adjustment hole "4") the clearance between needle eye and hook point is 0.8 mm and the max. clearance between hook point and needle is 0.1 mm

- .1 Adjust needle bar (screws 1, Fig. 4).
- .2 Adjust hook (screws 2, Fig. 3).

38 Bobbin case opener height

Requirement: When bobbin case opener 3 is at its left reversal point (Fig. 5) the opening finger and the stop on hook base base 4 (Fig. 6) must be level with each other.

It must be possible to remove the bobbin case without hindrance.

Turn eccentric bearing 5 (screw 6, Fig. 7).

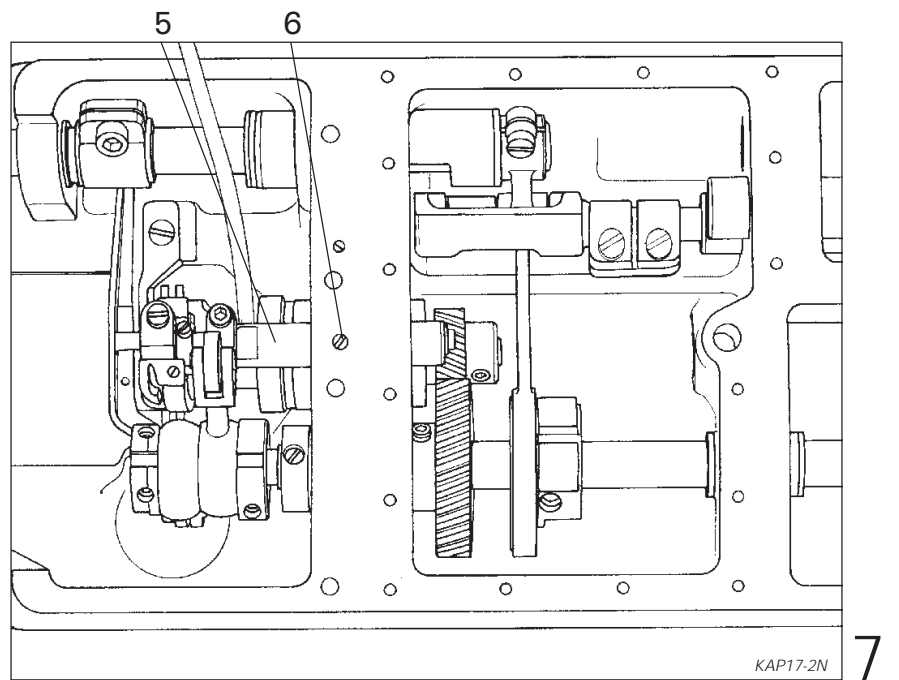
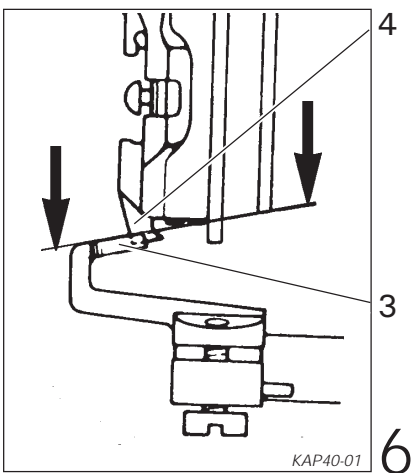
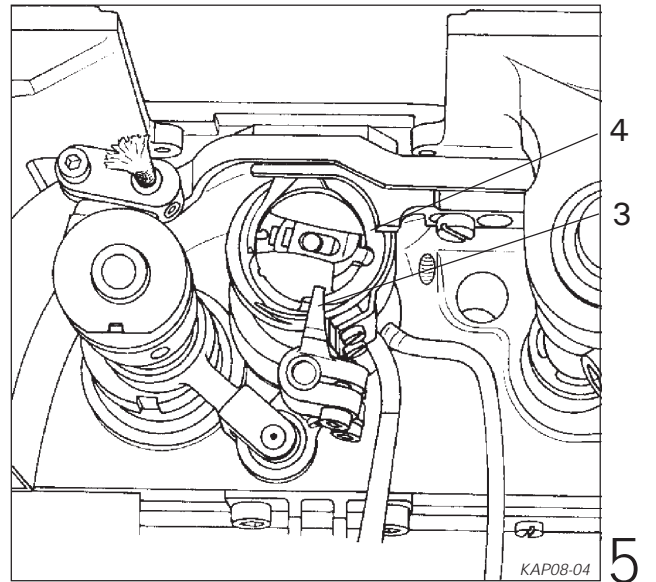
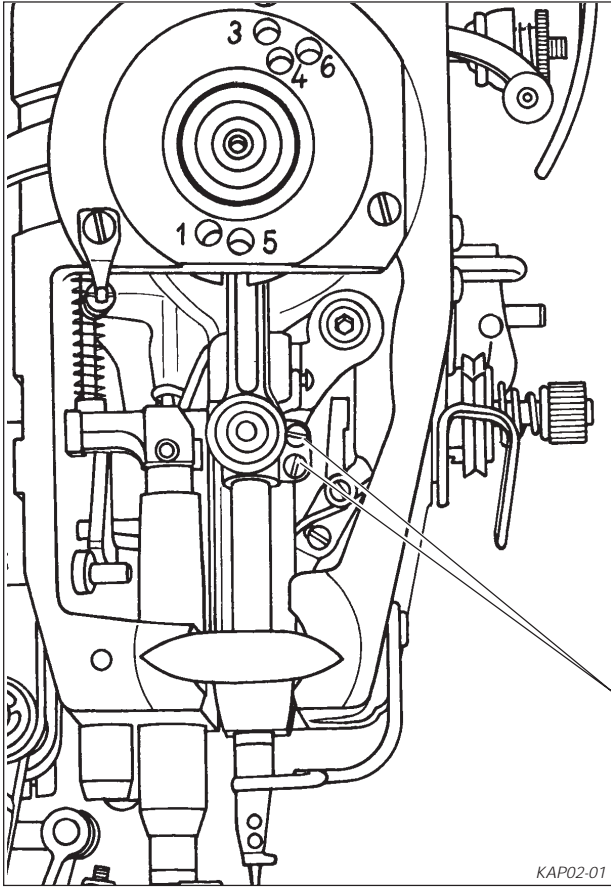
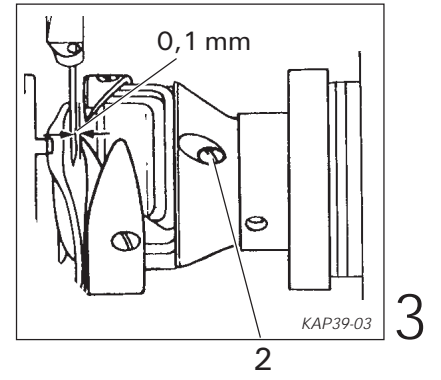
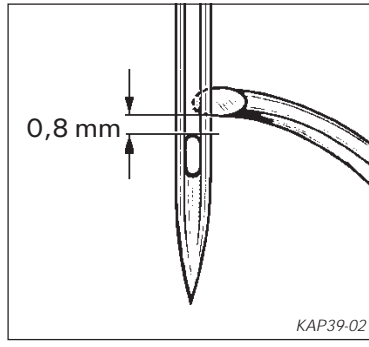
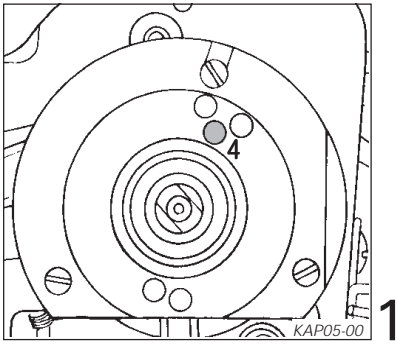

39 Bobbin case opener position

Requirement: The clearance between bobbin case opening finger 1 and the edge of hook base 2 is 0.8 mm (Fig. 1).

At the left reversal point of opener 3, hook base 4 must be deflected from positioning finger 5 by 0.3 mm (Fig.2)

After adjustment of opening finger 1 (Fig. 2) fixing collar 6 (Fig. 3) must be moved against the opening finger and stop screw 7 set against stop pin 8.

- .1 Axial and radial adjustment of bobbin case opening finger 1 at left reversal point of bobbin case opening shaft (screw 9).
- .2 Fixing collar 6 (screw 7).

40 Bobbin case opener movement

Requirement: When the needle bar is 1.8 mm past b.d.c. (= adjustment hole "4"), bobbin case opener 3 (Fig. 4) must be at its right reversal point.

Eccentric 10 (screws 11).

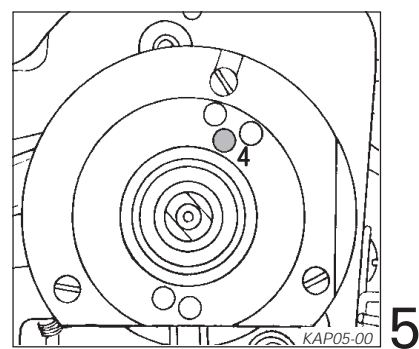
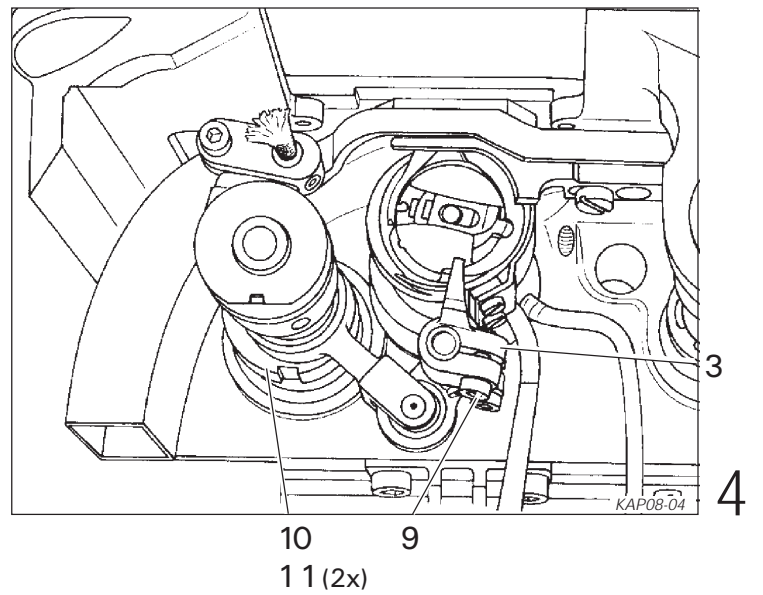
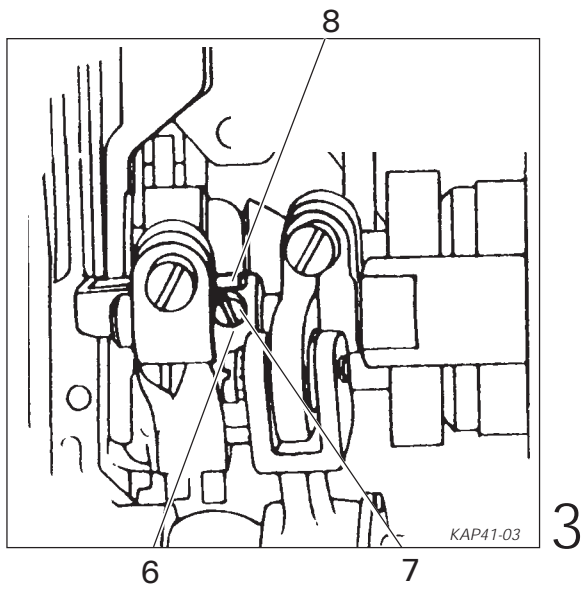
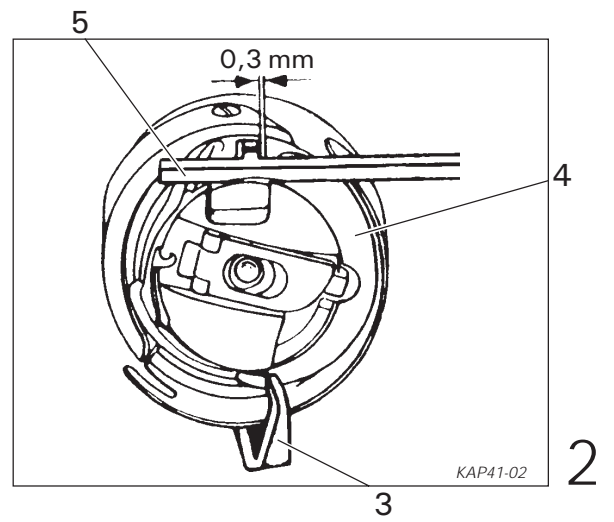
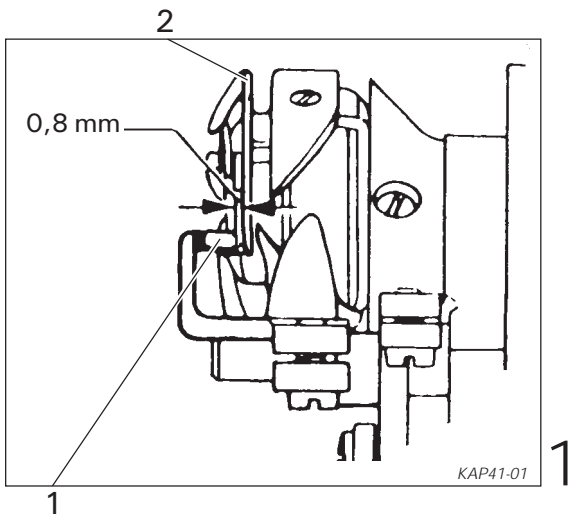

41 Needle thread tension release

Requirement: When the presser bar lifter is raised, the tension disks must be 0.5 mm apart (Fig. 1).

Tension actuator 1 (screw 2).

42 Thread check spring and thread regulator

Requirement: Thread check spring stroke = 5 to 7 mm

Thread regulator 3 (Fig. 2) must be roughly in the middle.

Both adjustments depend on the thread and the material and may deviate slightly from this basic setting.

- .1 Check spring stroke: loosen clamp plate (screws) and turn thread tension accordingly.
- .2 Thread regulator 3 (screws 5).

43 Bobbin winder

Requirement: When the bobbin winder is engaged, the winding spindle must be driven reliably.

When it is disengaged, friction wheel 6 (Fig. 3) must not touch winder driving wheel 7.

Axial adjustment of bobbin winder driving wheel 7 (screws 8).

Requirement: The bobbin winder must switch off automatically when the amount of wound thread is about 1 mm from the edge of the bobbin.

Adjust pin 9 (screw 10).

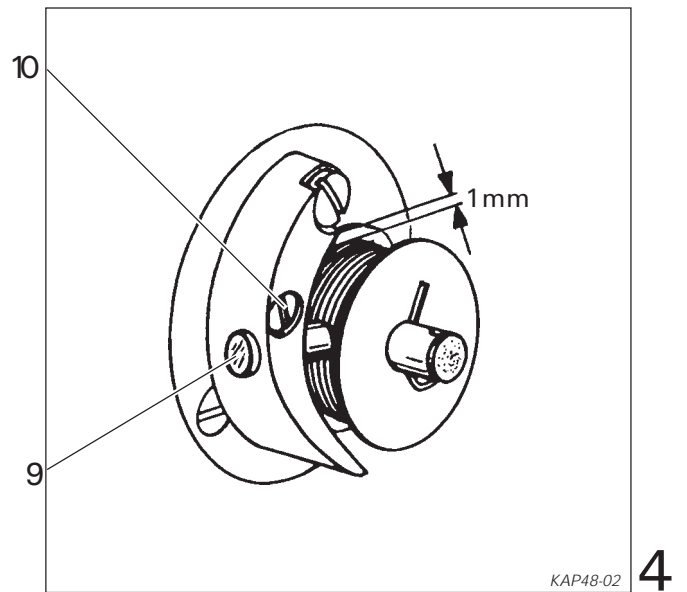
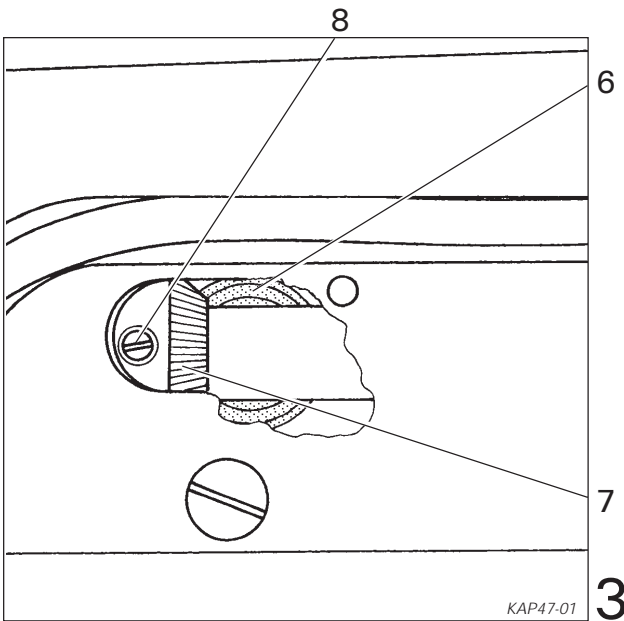
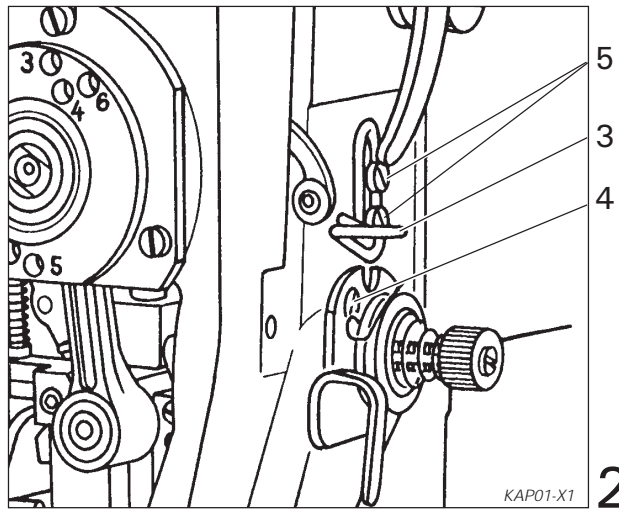
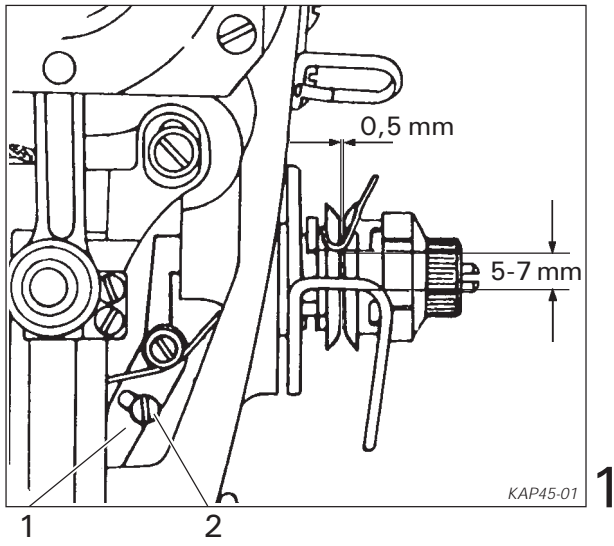

44 Position of vibrating presser to lifting presser

Requirement: When the presser foot is raised by the lifting lever and the take-up is at the top of its stroke, the teeth of top feed foot 1 (Fig. 1) must not protrude under presser foot shoe 2.

Adjust on eccentric sleeve 3 (screw 4).

45 Pressure of vibrating- and lifting presser

Requirement: The pressure of the vibrating- and lifting pressers must be adapted to each other so that perfect feeding is ensured, even at the highest sewing speed.

- .1 Vibrating presser, basic adjustment: screw 5 (Fig. 2) flush with beginning of thread.
- .2 Lifting presser, basic adjustment: screw 6 at a distance of 12 mm from needle head.

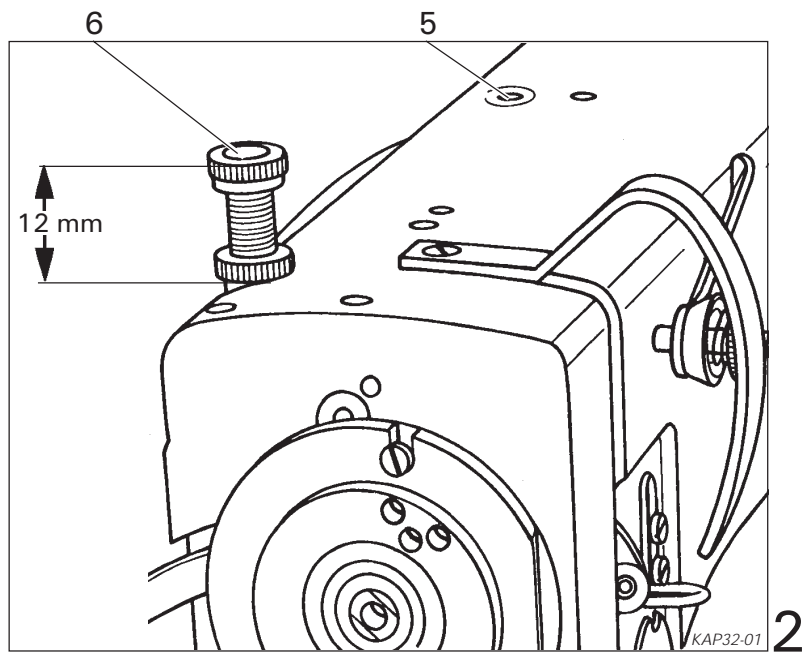
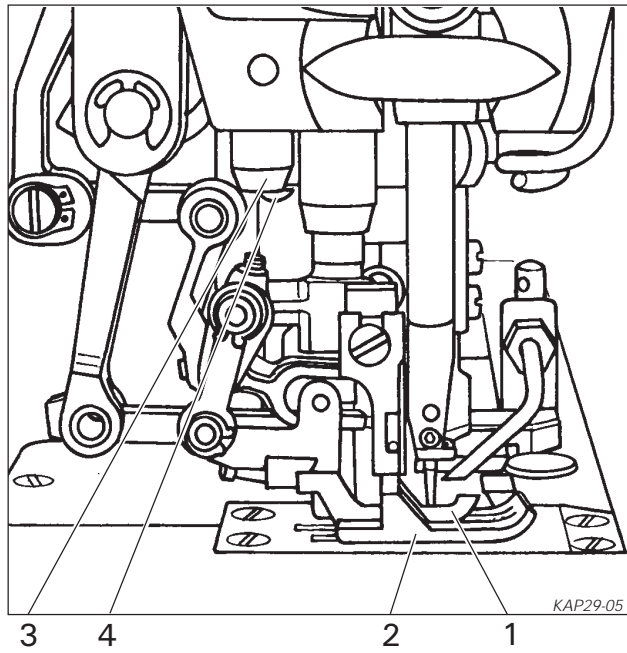

46 Dismantling and re-fitting the take-up lever

46.1 Dismantling

- .1 Take out screws 1 (Fig.1)
- .2 Loosen screw 2 (caution! Loosen correct screw!).
- .3 Pull off bearing plate 3 with crank 4 parallel.
- .4 Loosen screws 5 (Fig. 2).
- .5 Pull bearing pin 6 (Fig. 3) out, using an M4 screw (from gear cover), pressing lightly against take-up lever link 7.
- .6 Remove cover 8.
- .7 Loosen the clamp screws of eccentric pin 9 in arm shaft crank 10 through access window (8).
- .8 Set needle bar roughly at bottom dead centre.
- .9 Carefully pull out take-up lever 11 together with needle bar crank 12.

46.2 Re-fitting

- .1 Place take-up lever 11 together with needle bar crank 12 into arm shaft crank 10 and onto needle bar stud 13.
- .2 Swing up take-up lever link 7, insert bearing pin 6.
Position take-up lever in middle of housing slot, set bearing pin 6 and rear bearing bush without play against take-up lever link 7 and tighten screw 5 firmly.
- .3 Set needle bar at bottom dead centre.
- .4 Set eccentric side of eccentric pin 9 towards rear (see arrow at 9).
Observe correct direction!
- .5 Replace bearing plate 3 together with crank 4.

Note: It must be possible to move the bearing plate back and forth easily!
If there is any binding, the take-up lever is jammed, and adjustments 2.3 and 2.4 have to be repeated.

- .6 Tighten screws 1.
- .7 Tighten screw 2.
- .8 Tighten clamp screws of eccentric pin 9 in arm shaft crank 10 firmly through window 8.
- .9 Check that the two screws in the arm shaft crank are really tight.

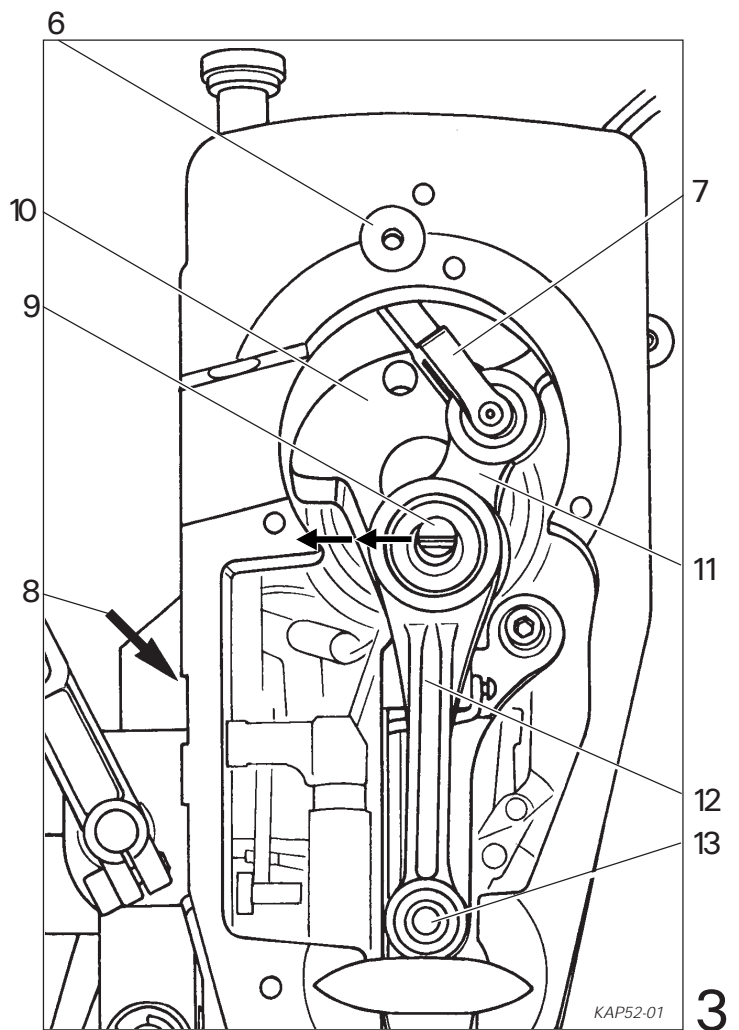
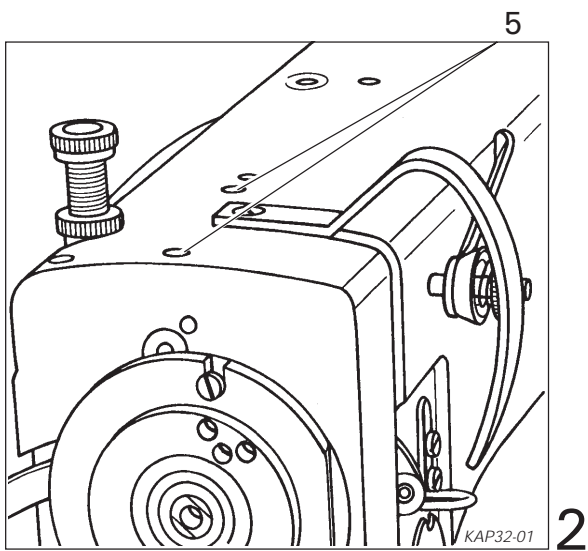
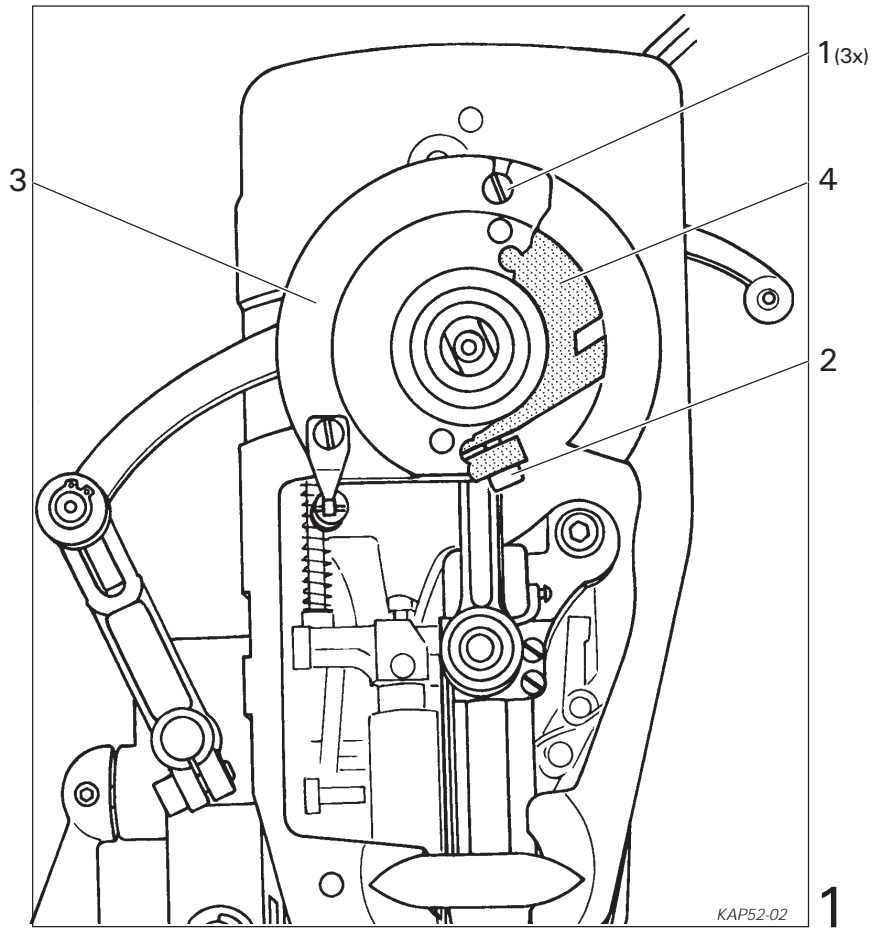

47 Automatic backtacking system

Requirement: When cylinder 1 (Fig. 1) is extended, the machine must sew backwards.

- .1 Fit link 2 (Fig. 2).
- .2 Set stitch length at " 3 mm" .
- .3 With cylinder 1 retracted, set lever 3 (Fig. 1) against lever 4 (screw 5).
- .4 Place actuating lever 6 against lever 3 and tighten screw 5.
- .5 Take off link 2.
- .6 Select correct motor setting on control panel 7 (Fig. 3) (cf. motor manufacturer's literature).
- .7 Sew a sample seam.

48 Stitch condensation system

Requirement: When cylinder 8 (Fig. 1) is extended the machine must sew at a shorter stitch length than the one set on the feed regulator.

- .1 Switch on stitch condensation (key  (LED on).
- .2 Sew a sample seam.
- .3 Set the condensation stitch length: bracket 9 (screws 10).

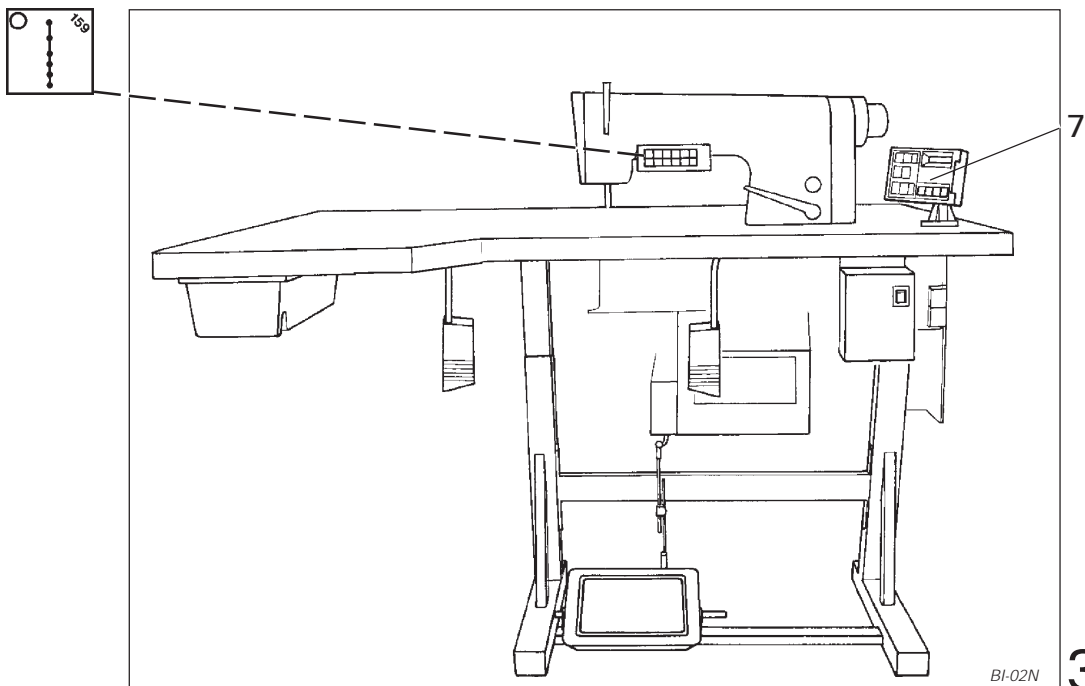
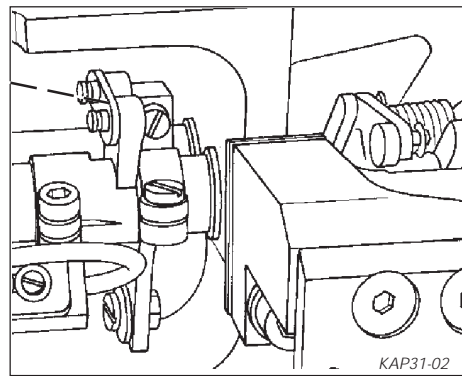
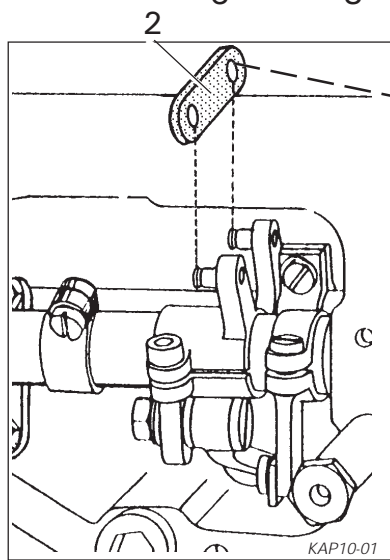
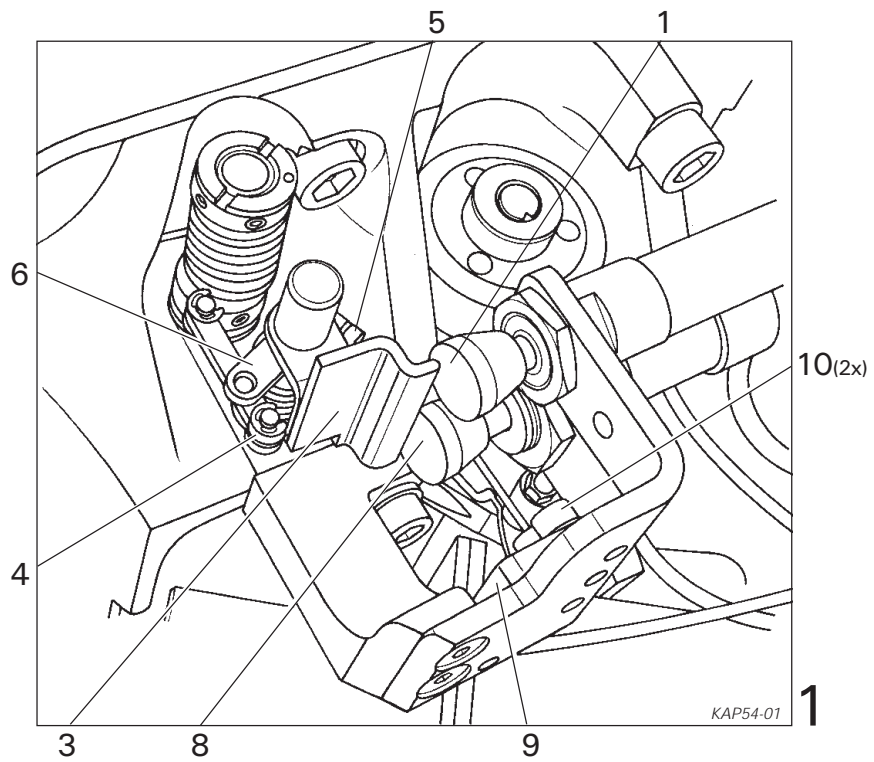



3

49 Edge trimmer system (only on 3822-1/22)



49.1 Trimming movement

Requirement: Top dead centre of needle bar (= adjustment hole "5", Fig. 1) = top of knife stroke.

- .1  Switch on trimming mechanism (key , LED on, Fig. 2).
- .2 Set needle bar at top of its stroke (balance wheel).
- .3 Adjustment: turn eccentric 1 until top knife is at top of its stroke (screws 2, Fig. 3).



49.2 Neutral point (no cutting movement)

Requirement: When the trimming mechanism is disengaged and the balance wheel is turned, there must be no up- or downward movement.

- .1  Switch off trimming mechanism (key , LED off, Fig. 2).
- .2 Turn eccentric pin 3 (Fig. 3) so that eyes of levers 4 and 5 are aligned with each other (screw 6).
- .3 Turn lever 7 until top knife is motionless when balance wheel is turned (screw 8).

49.3 Knife height

Requirement: When the knife is in its lowest position the front of the cutting edge must be about 0.5 mm under the top needle plate surface (Fig. 4)

- .1 Remove presser foot
- .2  Switch on trimmer (key , LED on, Fig. 2)
- .3 Set top knife in lowest position (balance wheel).
- .4 Position top knife 9 (Fig. 5) according to requirement (screws 10).

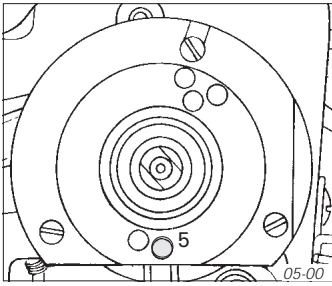

1

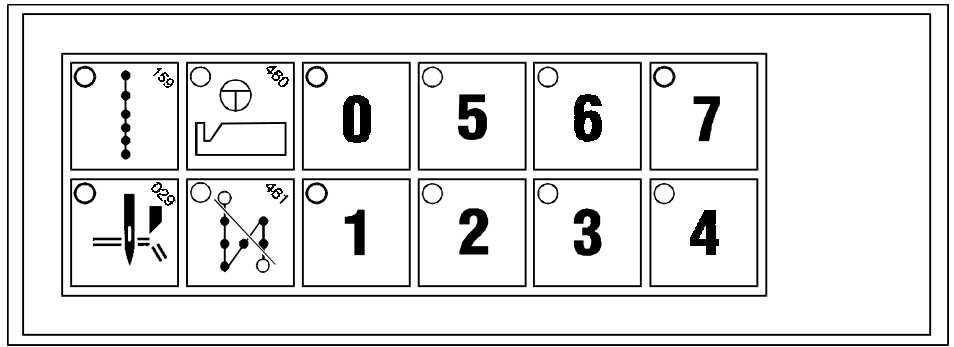

2

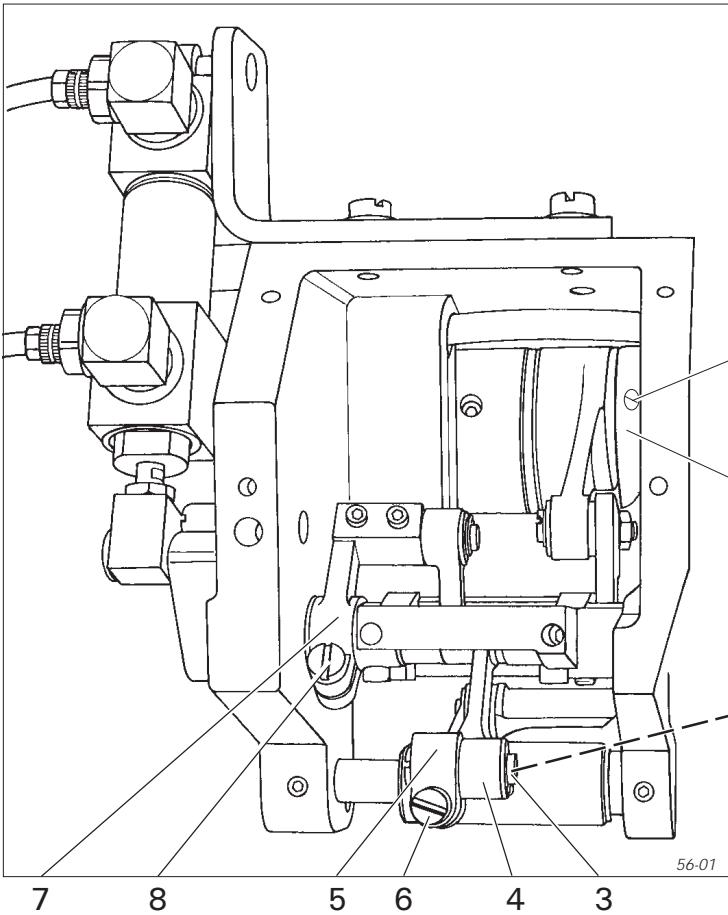

3

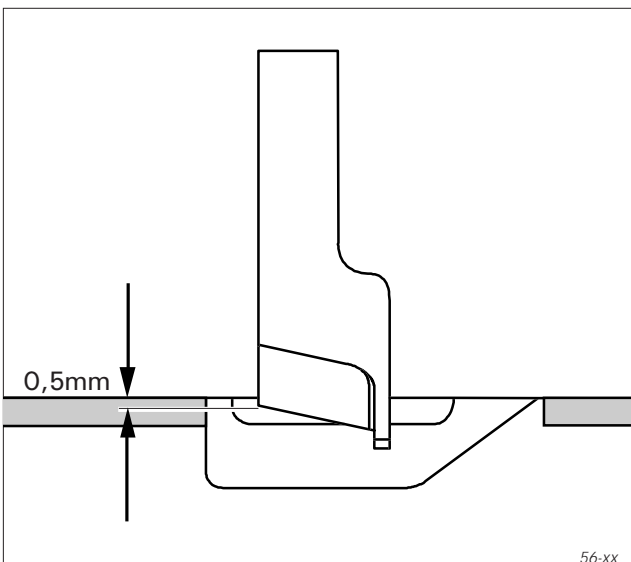
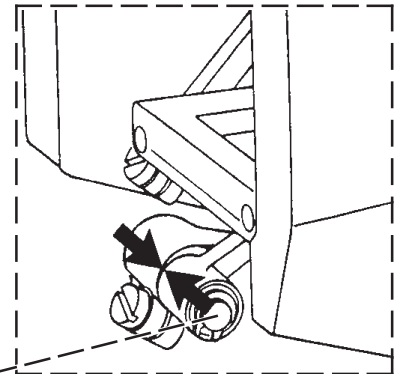

56-xx

4

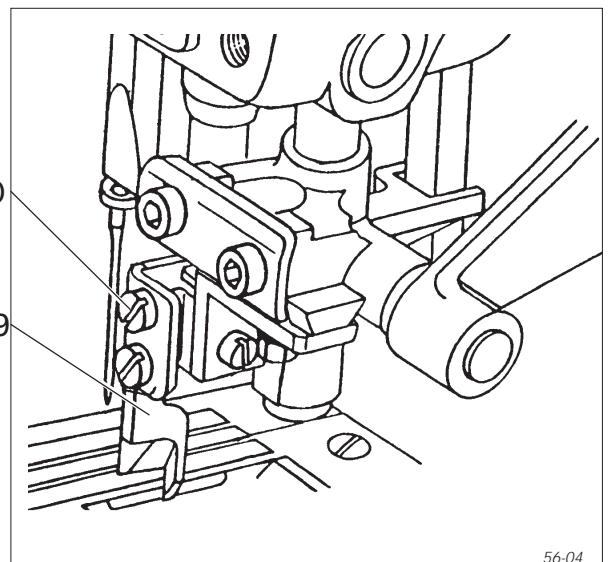

56-04

5



49.4 Positioning the top knife in sewing direction

Requirement: The needle must be at the middle of the top-knife cutting edge (Fig. 6).

Shift knife bracket 11 (Fig. 7) according to requirement (screw 12).

49.5 Positioning the top knife crosswise to sewing direction

Requirement: Top knife 9 must rest on the counter knife with a light pressure (the knife spur must not strike the counter knife!)

.1  Switch on the trimming mechanism (key , LED on, Fig. 2).

.2 Set top knife at lowest position (balance wheel).

.3 Place top knife with light pressure against counter knife (screws 13, Fig. 7).

Requirement: Top knife 9 (Fig. 8) must be at a slight diagonal to counter knife 14 (shearing action).

.4 Set knife bracket 11 (Fig. 7) at a slight diagonal (screw 15).

49.6 Adjusting the stop eccentric

Requirement: When stop 16 (Fig. 9) is resting on eccentric 17, there must be a clearance of about 5 mm between the front edge of housing 18 and lever 19.

.1 Disconnect compressed air.

.2 Pull plunger 20 fully downwards.

.3 Making sure that stop 16 is resting on eccentric 17, set eccentric 17 according to requirement (screw 21).

.4 Re-connect compressed air.

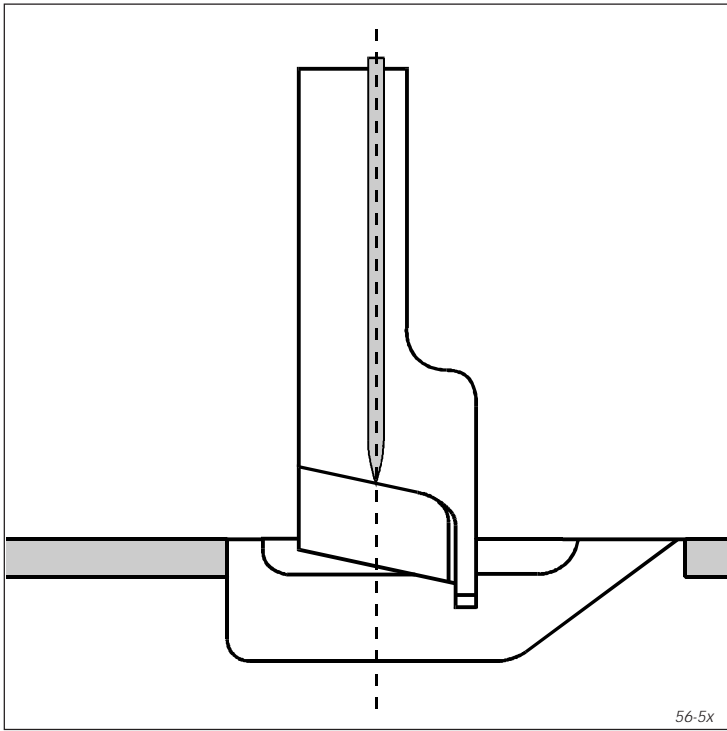

56-5x

6

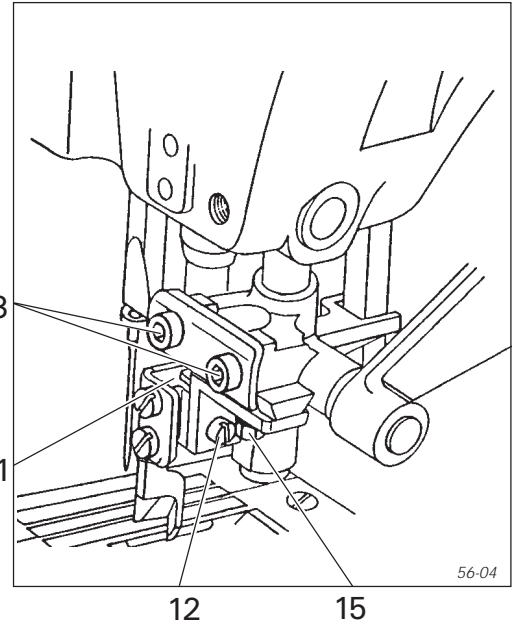

56-04

7

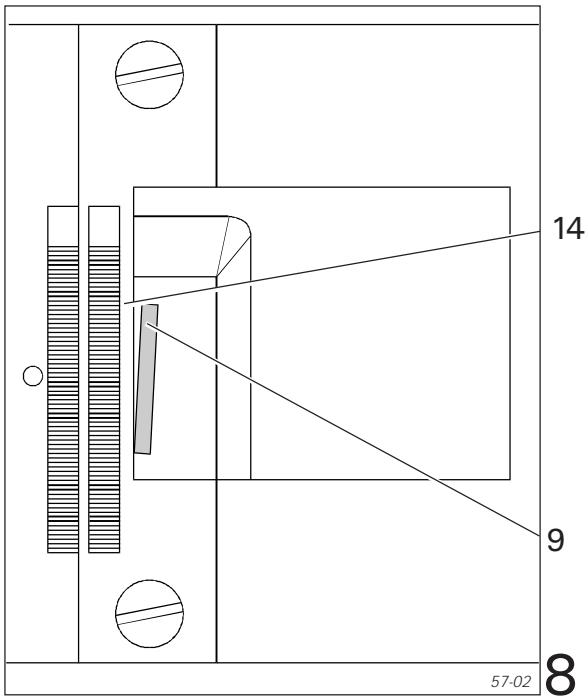

57-02

8

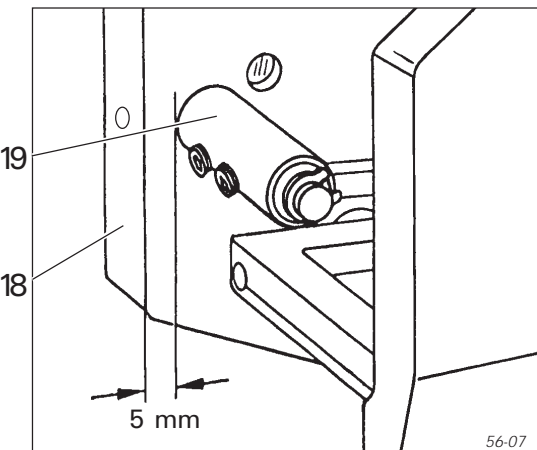

56-07

10

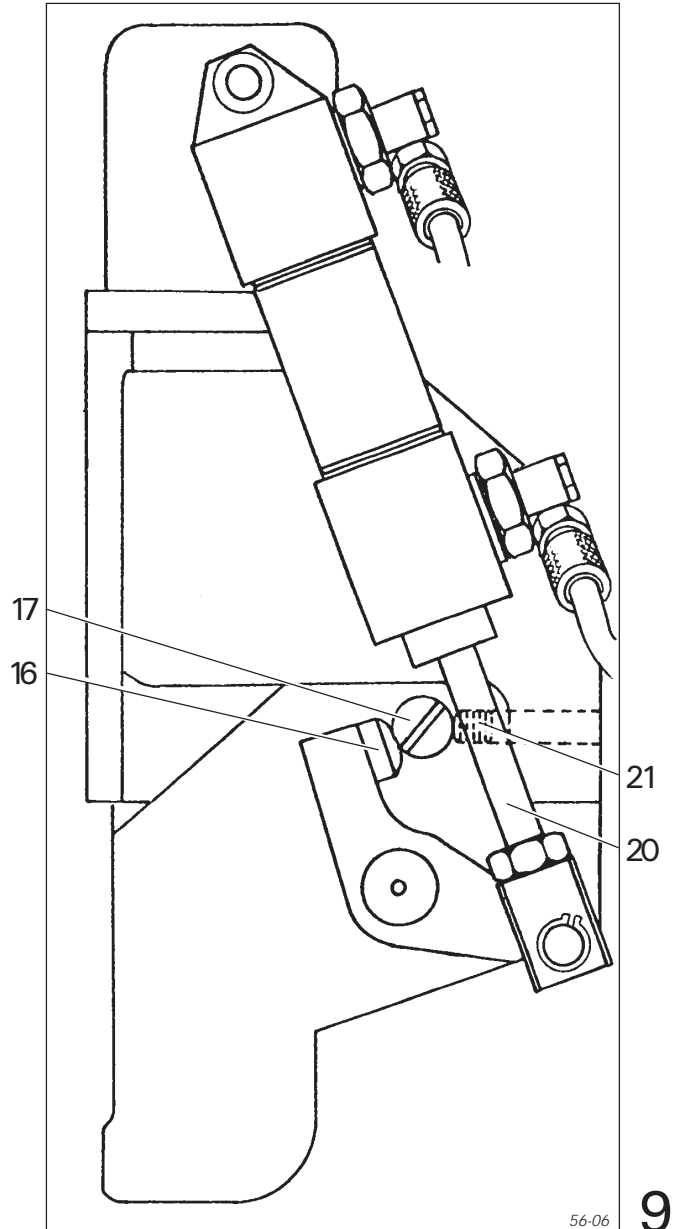

56-06

9

50 Step-cut (feather-cut) trimming mechanism (only on 3822-1/24)

50.1 Note on motor control



Setting deviates from 1st stopping position !!

Requirement: When the teeth of the descending feed dog are in line with the top surface of the needle plate, the first stopping position must be made.

50.2 Preparations for adjusting the trimmer

Remove:

- Presser foot
- Complete top knife bracket 1 (loosen screws 2, Fig. 1)
- Cover of knife drive

50.3 Setting the longest knife stroke

Set actuating lever 3 (Fig. 2) right at bottom of elongated hole in lever 4 (nut 5).

50.4 Setting the top reversal point of the knife

Requirement: When the eye of the descending needle is level with the needle plate, the downwards movement of the top knife must begin.

.1



Switch on trimming mechanism (key , LED on, Fig. 3).

.2

Adjustment: eccentric 6.

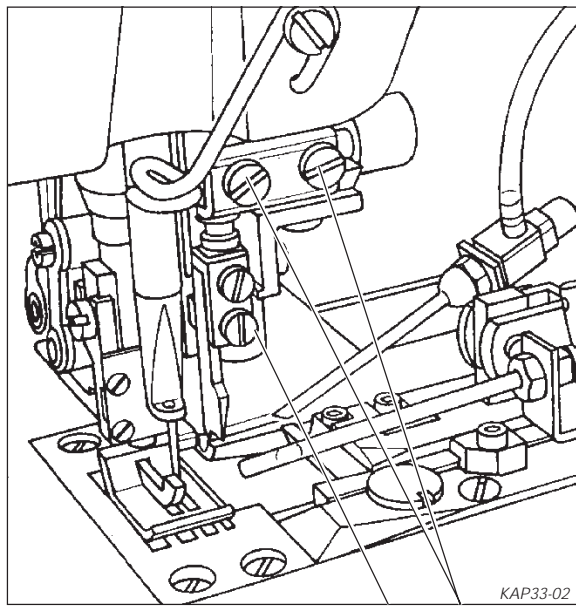

1 2

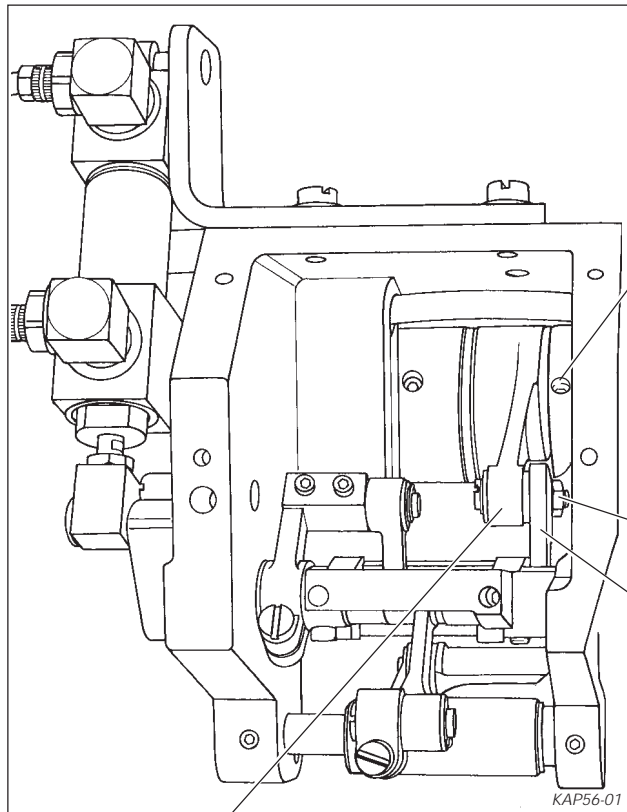

3 4 5 6

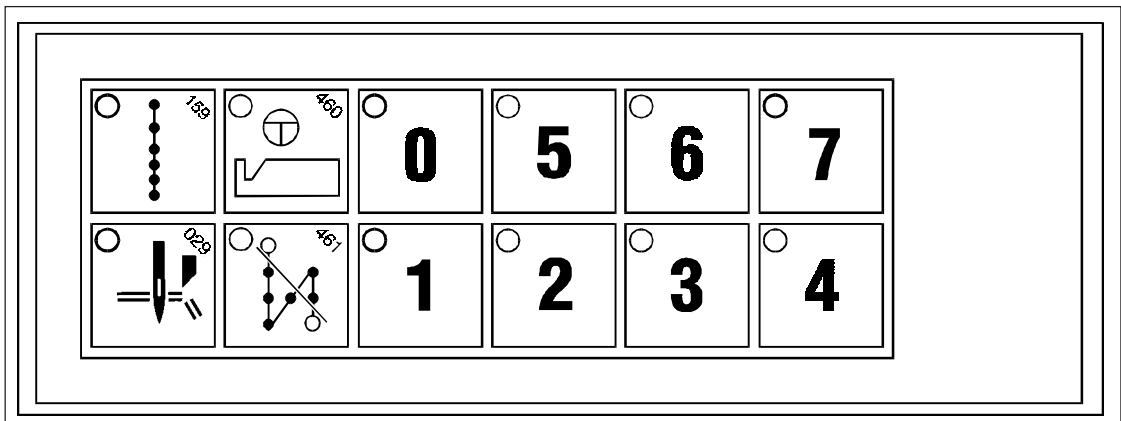

3

50.5 Positioning the top knife bracket and front top knife according to the needle plate

Note: In carrying out the adjustment and checks make sure that the top and bottom knives do not strike each other.

- .1 Remove rear top knife (Fig. 4, screws 8).
- .2 Push in top knife assembly 1 (Fig. 5, tighten screws 2 just a little)

50.5.1 Cutting angle of the front top knife

Requirement: Front top knife 9 (Fig. 5) must be diagonal by 0.1 mm to bottom knife 10 (cutting angle) and rest against it without any side pressure (Fig. 6)

- .3 Push top knife bracket 1 so far forward that front top knife 9 rests lightly against bottom knife (screws 2).
- .4 Turn top knife bracket 11 (Fig. 5) to one side according to requirement (screw 12).

Check: with clearance gauge.

50.5.2 Cutting position of the front top knife

Requirement: The rear edge of front top knife 9 must be absolutely flush with the edge marked in Fig. 7 (see arrow).

Adjustment: Position knife bracket 1 (Fig. 1) according to requirement (screw 13).

50.5.3 Cutting pressure of the front top knife

Requirement: There must only be enough cutting pressure as absolutely necessary.

After the cutting pressure is set, the diagonal of 0.1 mm (cutting angle) set according to chapter 57.5.1 must not be less than 0.05 mm.)

- .4 Take out filter 4
- .5 Clean filter and bowl with petroleum.
- .6 Blow filter out **from the inside** with compressed air.

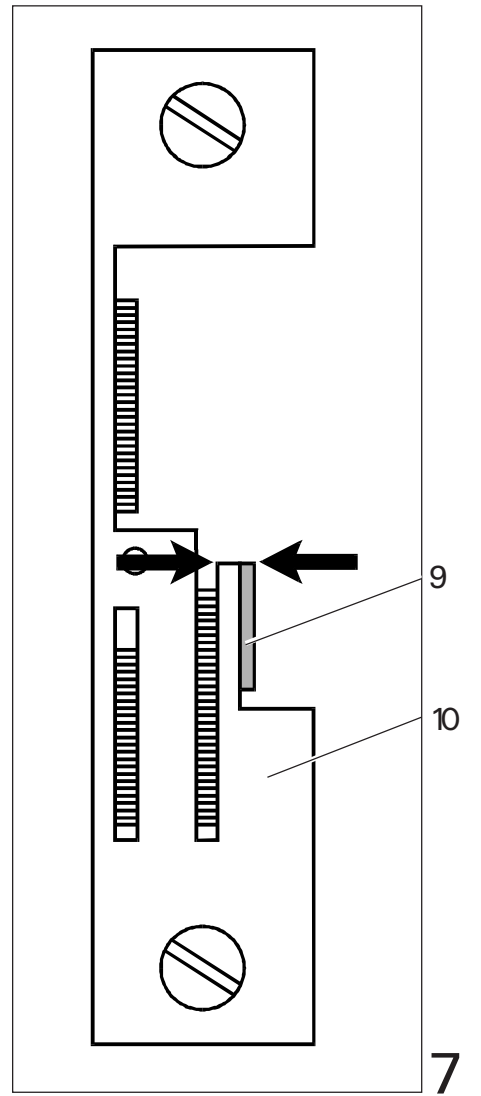
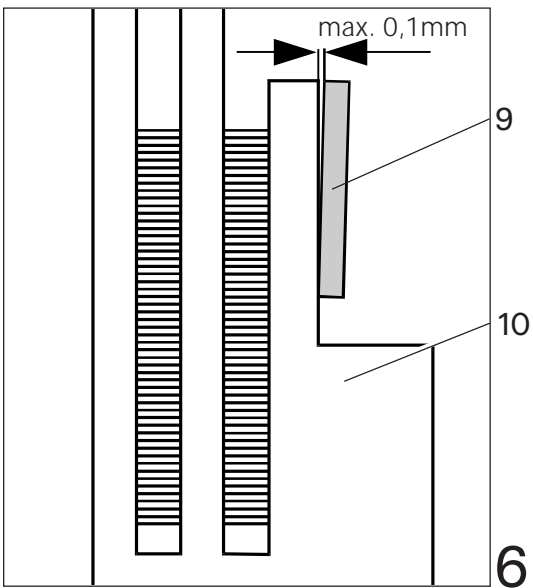
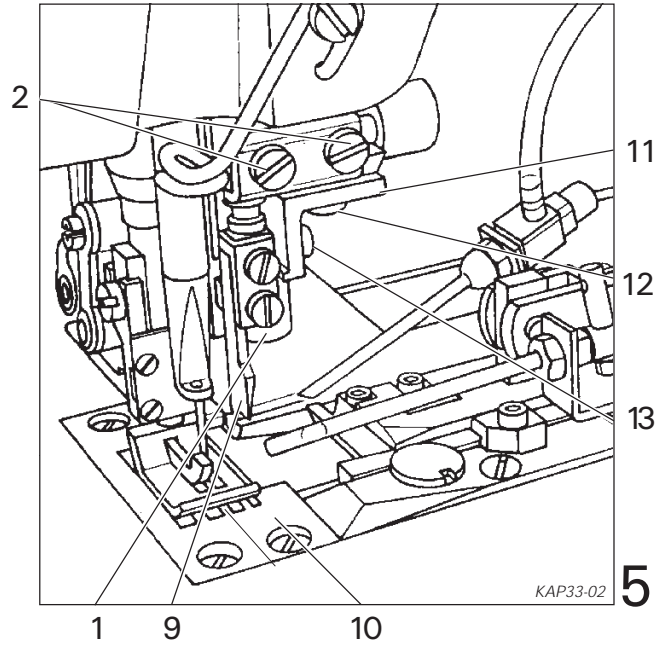
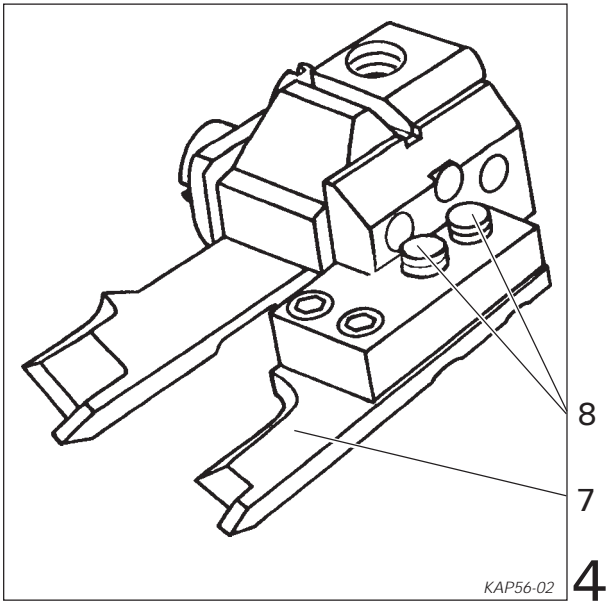

50.6 Neutral point of top knife movement

Requirement: When the trimming mechanism is switched off, the top knives must be motionless.



Switch of trimming mechanism (key , LED off, Fig. 8).

Set link 14 (Fig. 9), while turning the balance wheel, so far forward or backward that the top knives become motionless (screw 15).

50.7 Setting top knife at highest point

Requirement: The top knife must be set at the highest point of its stroke

Adjustment: eccentric screw 16 (screw 17).

50.8 Positioning the rear top knife and hook knife (after changing top knives)

(For adjustments required after a new top knife bracket is fitted, please see chapter 57.11.)

50.8.1 Lateral position of the rear top knife to hook knife

Requirement: The rear edge of rear top knife 7 (Fig. 11) must be flush with hook knife 20 (see arrow in Fig. 11).

- .1 Remove front top knife 9 (Fig. 10, screws 18).
- .2 Loosen knife retaining screws 8 (Fig. 12) and position rear top knife to side according to requirement.
- .3 Continued on page 56.

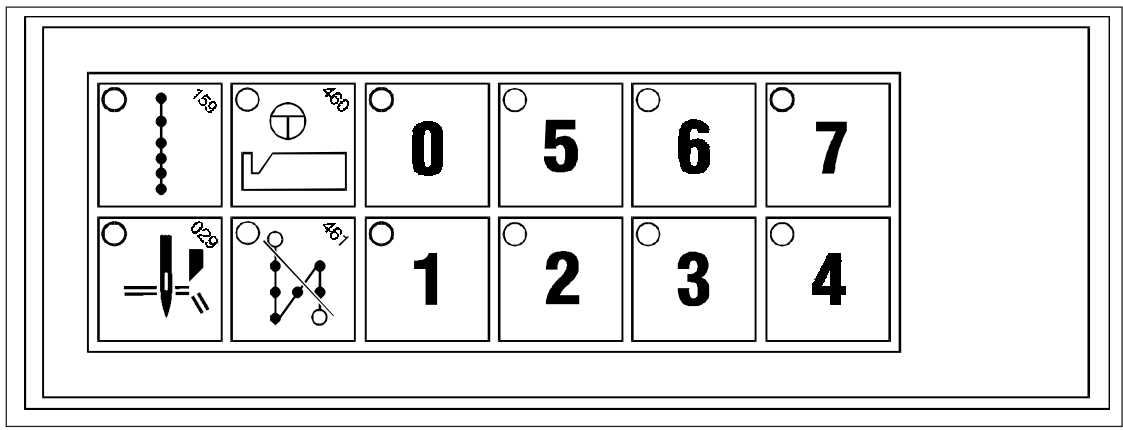

8

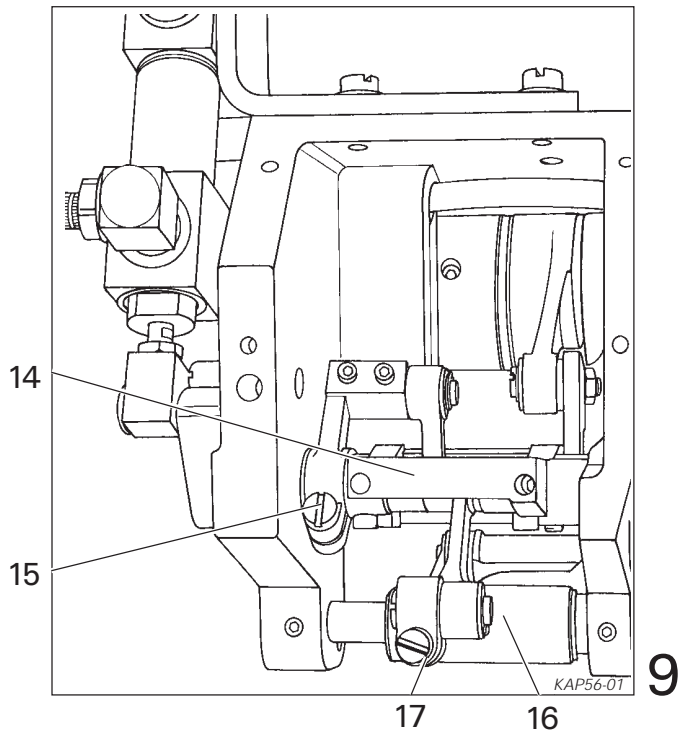

9

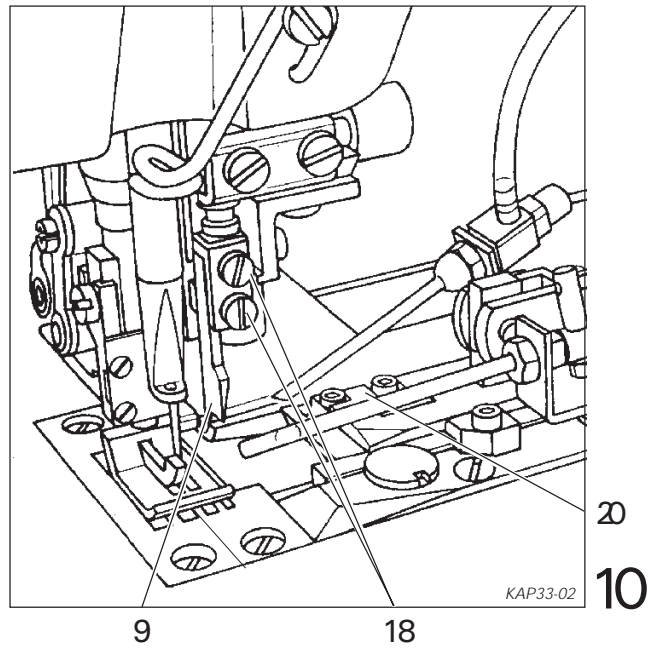

10

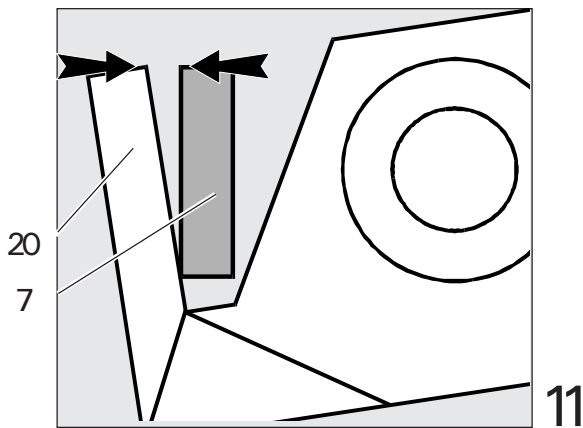

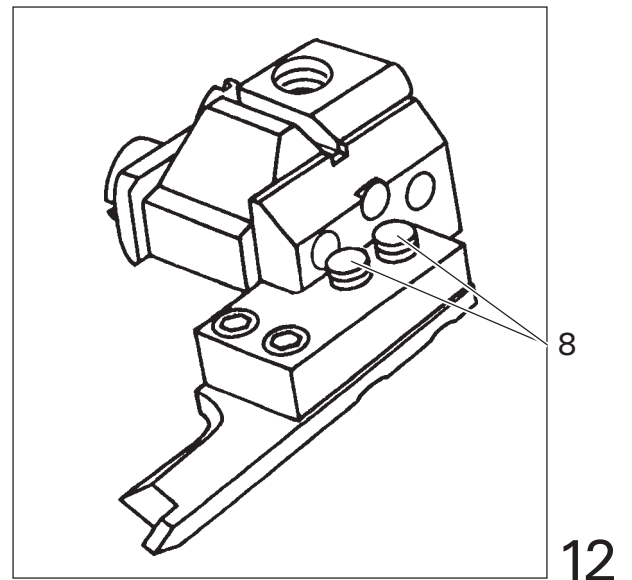

11



12

57.8.2 Cutting angle of the rear top knife in relation to the hook knife

Requirement: Hook knife 20 must be at a diagonal to rear top knife 7 (without lateral pressure) by 0.05 to 0.1 mm (cutting angle, Fig. 15).

- .1 Switch on trimming mechanism (key , LED on, Fig. 13).
Switch on step-cut (feather-cut) trimming mechanism (key , LED on.)
- .2 Disconnect compressed air.
- .3 Move hook knife 20 to the cutting position by means of cylinder 21 (unit must move freely and without lateral play!)
- .4 Set rear top knife 7 in cutting position (balance wheel).
- .5 Set hook knife 20 in relation to hook knife 7 so that cutting angle corresponds with requirement (screw 22).
- .6 Re-connect compressed air.

57.8.3 Cutting pressure between rear top knife and hook knife

Requirement: The cutting pressure must only be as much as absolutely necessary.

After the cutting pressure is set, the diagonal position of hook knife 20 in relation to rear top knife 7 (cutting angle), set in chapter 50.8.2, must not be less than 0.05 mm.

Adjustment: adjust stop 23 (Fig. 14, screw 24).

Note: Make sure that cylinder 21 (Fig. 14) always moves through the full stroke limited by stop 23.
Therefore, no lint must be allowed to collect in the area of stop 23 (arrow in Fig. 14).

When the rear top knife loses sharpness, increase the cutting pressure by means of screw 24.



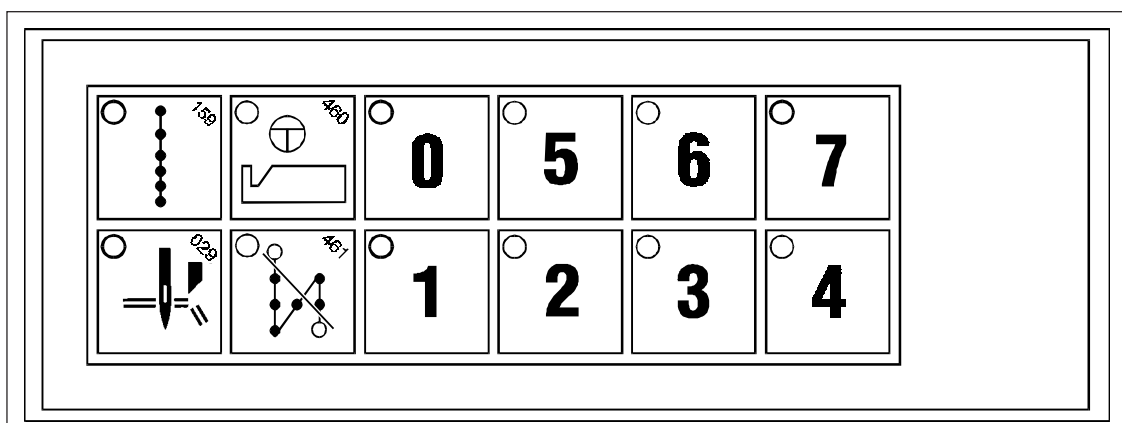

Do not increase the cutting pressure too much, or the hook knife may break!

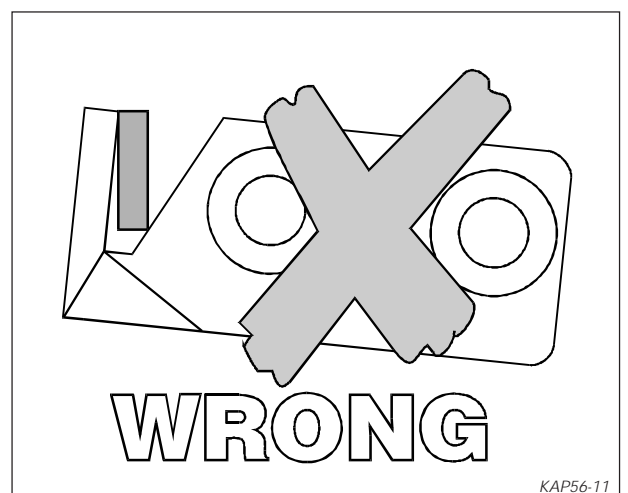
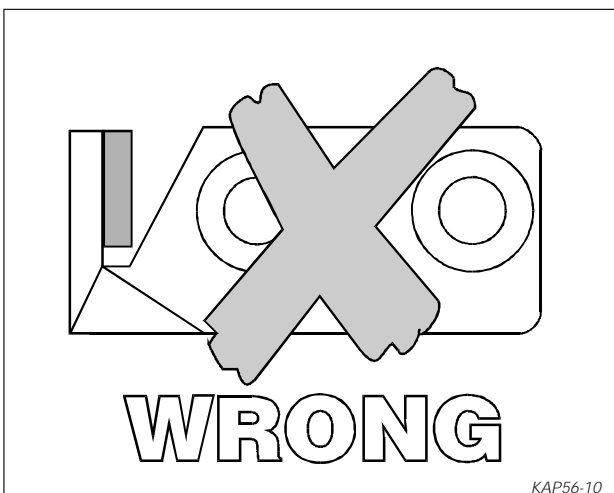
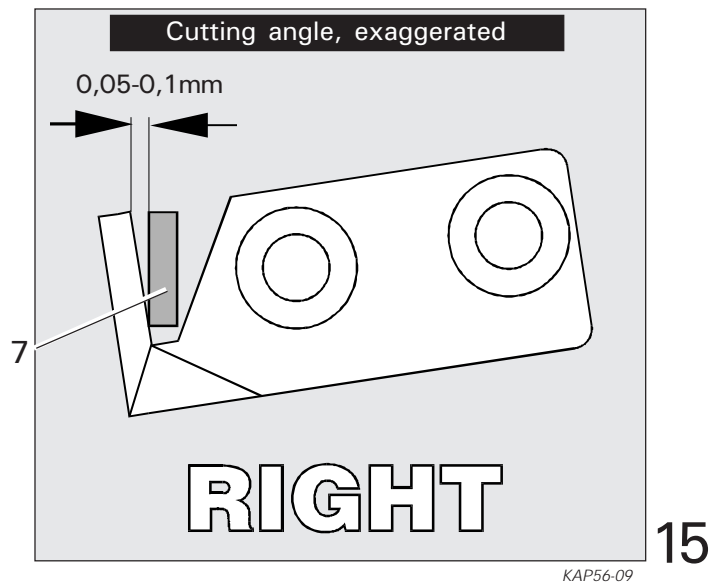
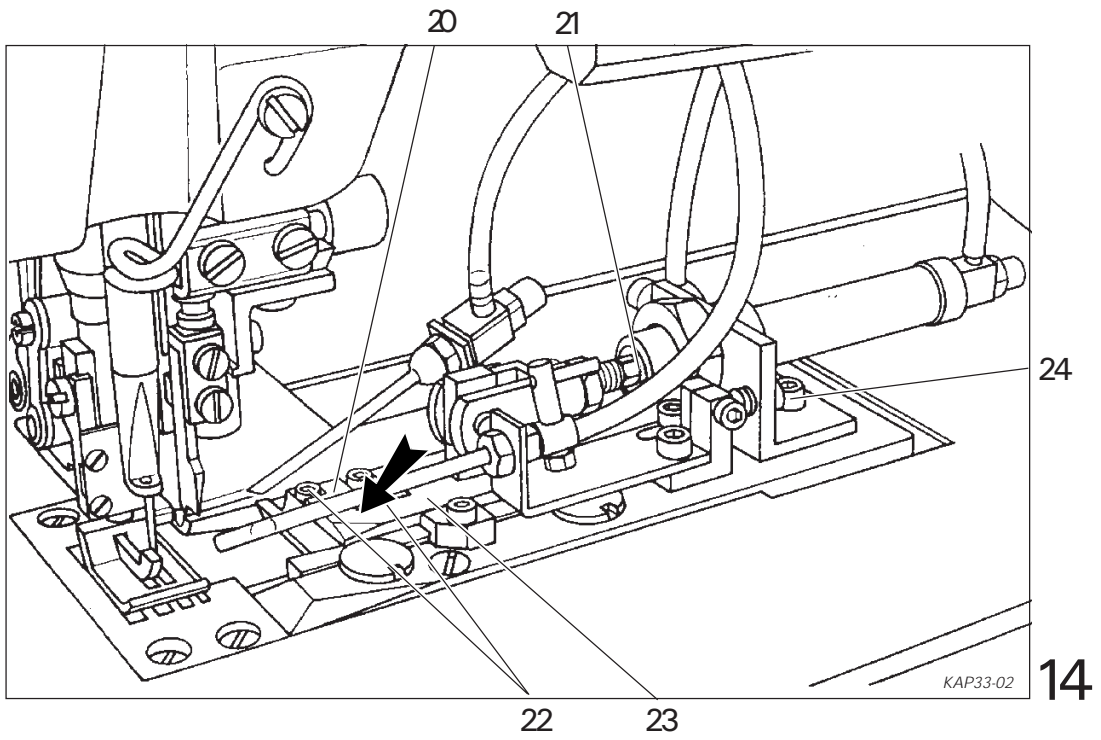





50.8.4 Setting the cutting depth of the rear top knife in relation to the hook knife

Requirement: In its lowest position, rear top knife 7 must cross hook knife by 0.5 mm (Fig.16).

- .1  Switch on trimming mechanism (key , LED on, Fig. 17).
- .2 Switch on hook knife (key , LED on)
- .3 Set top knife in cutting position; see also chapter 57.1).
- .4 Set hook knife at cutting position (knee switch 4, Fig. 18).
- .5 Set top knife height, eccentric 16, screw 17 (Fig. 19).

50.9 Setting the cutting depth of the front top knife

Requirement: Front top knife 9 (Fig. 21) must make two thirds of its cutting stroke before rear top knife 7 begins to cut.

- .1  Fit front top knife 9 (Fig. 20, screws 18).
- .2 Switch on trimming mechanism (key , LED on, Fig. 17).
- .3 Set top knives in highest position (balance wheel).
- .4 Engage hook knife 20 (knee switch 4, Fig. 18)
- .5 Adjust knife height (front top knife 9) according to requirement (screws 18, Fig. 21).

50.10 Setting the trimming margin

Requirement: The trimming margin must be set at 3.5 mm

Sew a sample seam and check the trimming margin.

Correction: On the two screws 25 (Fig. 21)
Caution, do not change cutting angle!

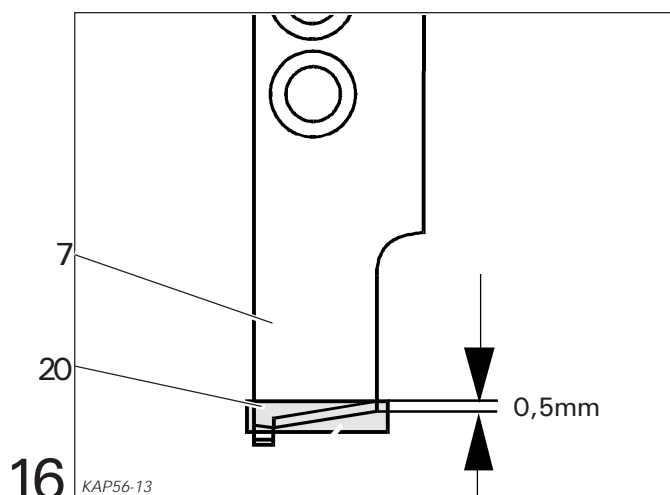

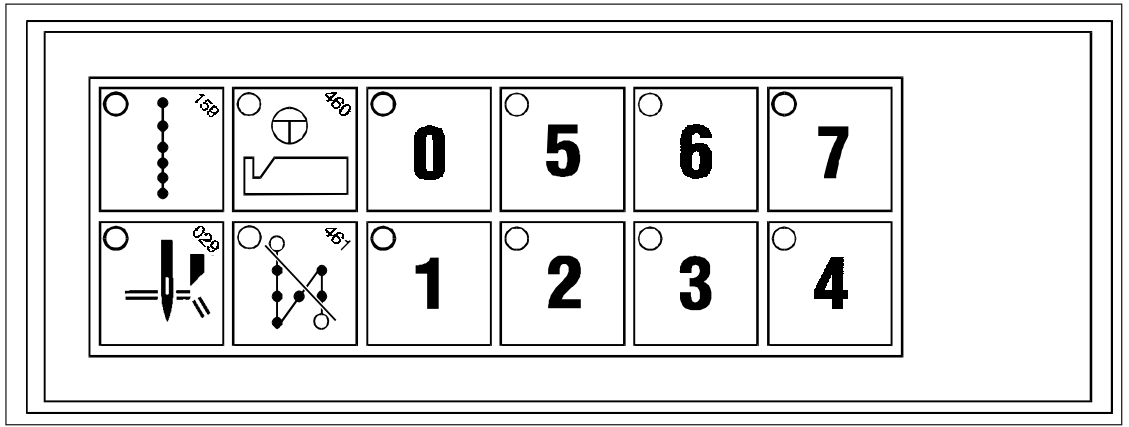

17

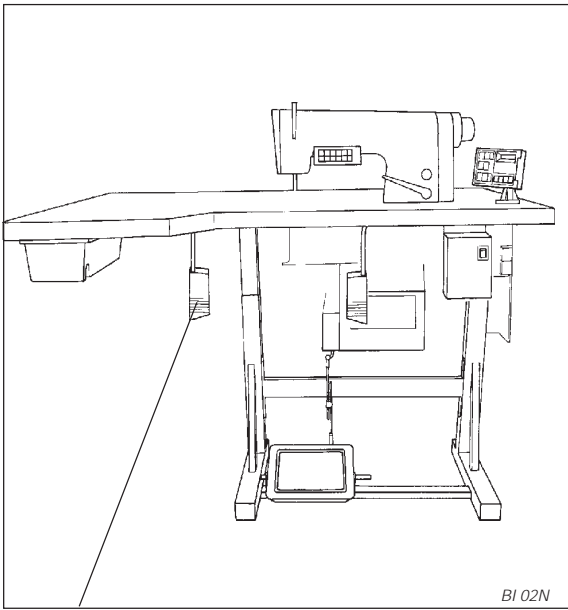

BI 02N

18

4

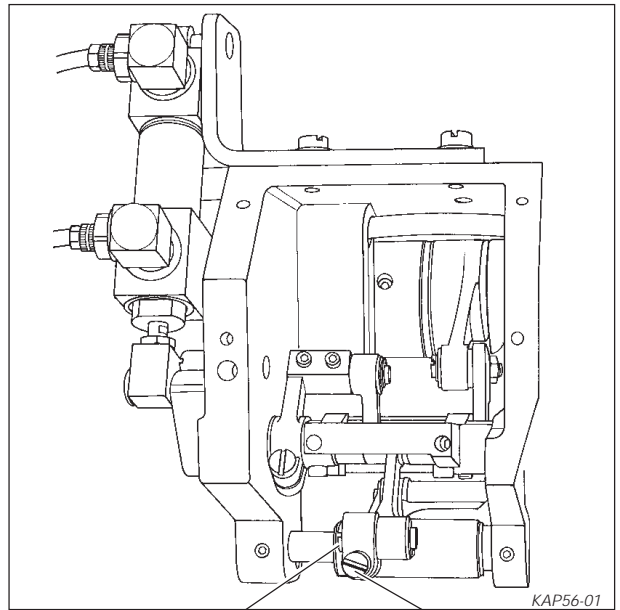

KAP56-01

19

16

17

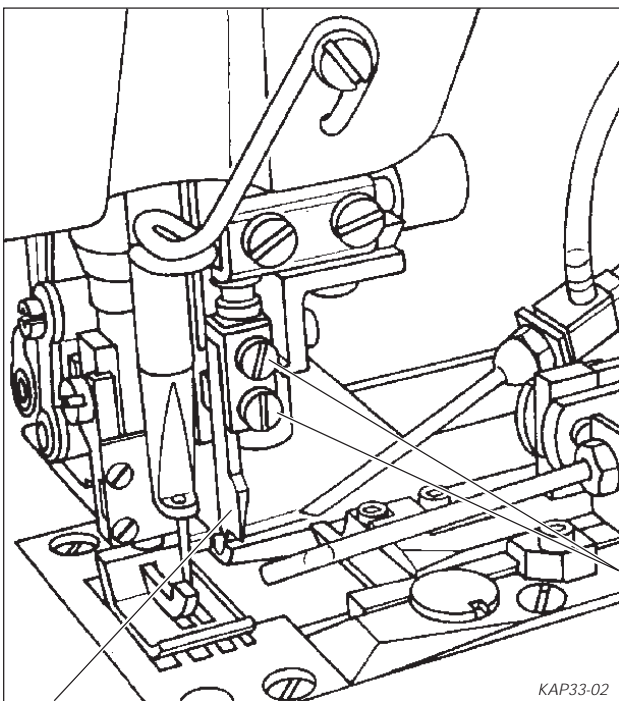

KAP33-02

20

9

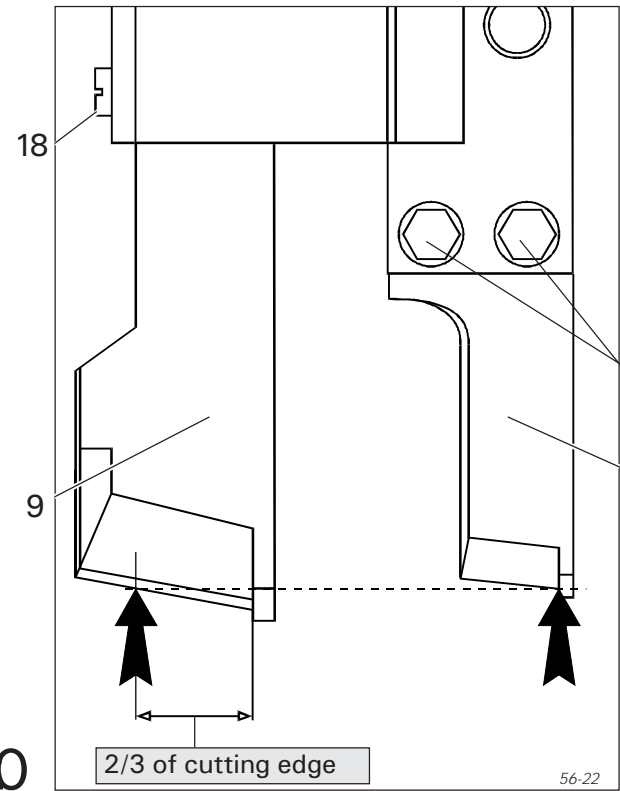

56-22

21

2/3 of cutting edge

50.11 Basic adjustments on the top knife mounting

Note: The following adjustment must only be carried out when

- a new knife mounting has been fitted (replacement)
- the adjustments on the existing mounting have been changed.

Adjustment of top knife mounting are made with the latter fitted in the machine.

50.11.1 Cutting angle of the rear top knife

Requirement: Rear top knife 7 must be at a diagonal of 0.05 to 0.1 mm in relation to hook knife 20 (cutting angle).

Note: Adjustment is made on three allen screws; allen screw 26 is only accessible when rear top knife 7 has been removed.

- .1 Remove top knife 7.
- .2 Unscrew screws 26 and 27 just enough that they protrude by about 0.2 mm on the side of the top knife on which rear top knife 7 is afterwards fitted.
- .3 Cement in screws 26 and 27.
- .4 Screw on rear top knife 7.
- .5 Turn screw 28 in so that it is against the rear top knife, then cement it in.
- .6 Check cutting and cutting width.

Angle correction: remove rear top knife, then turn screw 26.

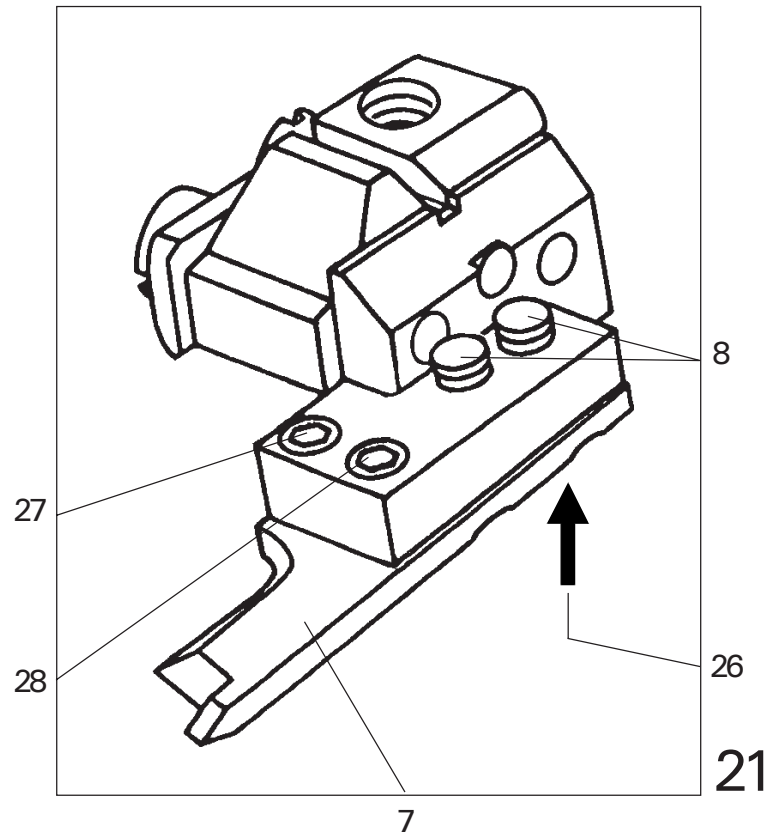

50.12 Sensor controlled monitoring of the hook knife

50.12.1 Function

Sensor 23 (fig. 22) detects whether hook knife 20 is in cutting position.

Cutting position of the hook knife

with optimum hook adjustment:

- cylinder 30 is fully extended
- pin 31 is in contact with stop bracket 32

Cutting position has been reached:

- LED 33 on sensor 29 lights up
- treadle is free, sewing and cutting are possible

Cutting position has not been reached:

- LED 33 on sensor 29 does not light up
- machine start is inhibited
- find out what the cause is (see section 50.12.3)

50.12.2 Sensor adjustment

Requirement: The sewing and cutting procedure must not start (if working with feathered edge trimmer) until hook knife 20 is in cutting position.

- .1 Preliminary work: Carry out optimum adjustment of hook knife 20 according to section 50.
- .2 Attach feeler gauge (0.1 mm) between stop bracket 32 and pin 31.
- .3 Press key :
 - hook knife 20 positions in cutting position.
- .4 Loosen screws 34 slightly.
- .5 Move sensor 29 with adjusting screws 35 (nuts 36) in the direction of hook knife 20 until LED 33 lights up.
- .6 Move sensor 29 with adjusting screws 35 (nuts 36) in the opposite direction until LED 33 just goes out again.
- .7 In this position tighten screws 34.
- .8 Check function.

Note: Consider motor parameters.

- start inhibitor parameter 624 I
- hook knife release parameter 671 I

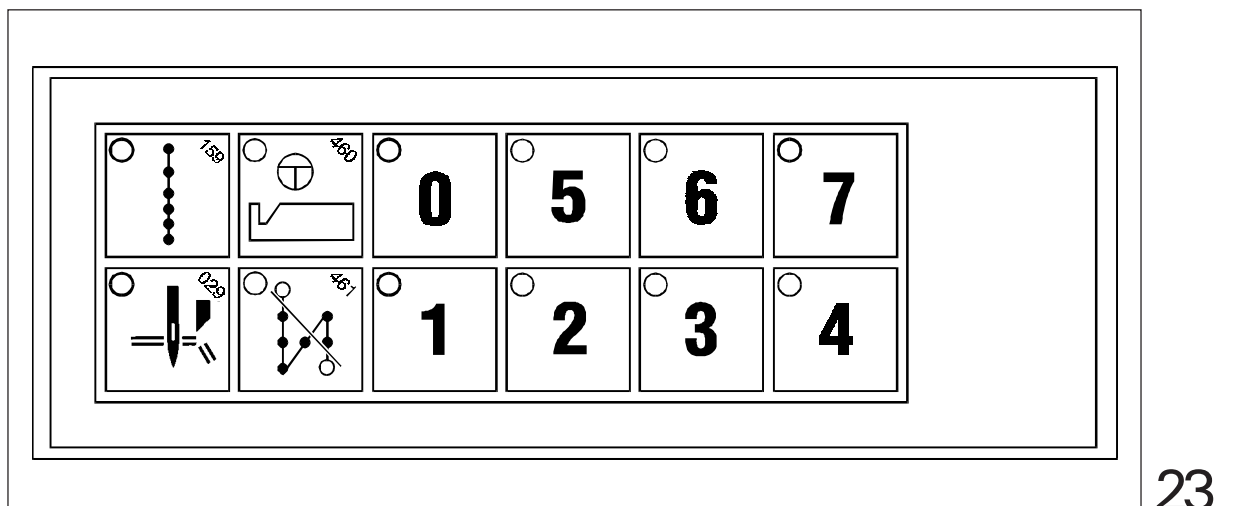
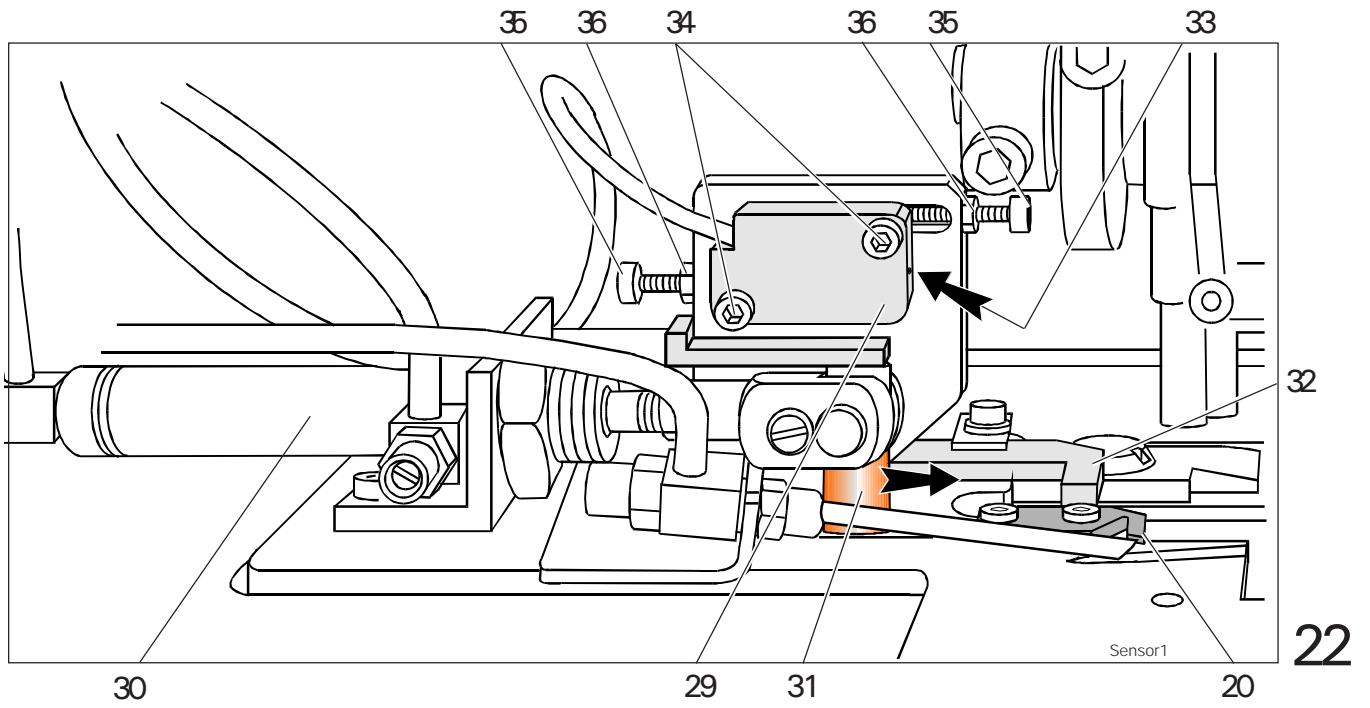

50.12.3 Fault finding and remedy

Sewing and cutting procedure is not started:

- .1 Position hook knife 20 (fig. 24) in starting position by pressing:

Either key 

or key 

or knee button 37 (fig. 26).

- .2 Find the cause for the disturbance

Possible causes:

- dirt between stop bracket 32 and pin 31
- lint is preventing hook knife 20 from reaching the cutting position
- dirt between slide 38 (fig. 24) and guide 39 (slide is binding)

- .3 Remove disturbance.

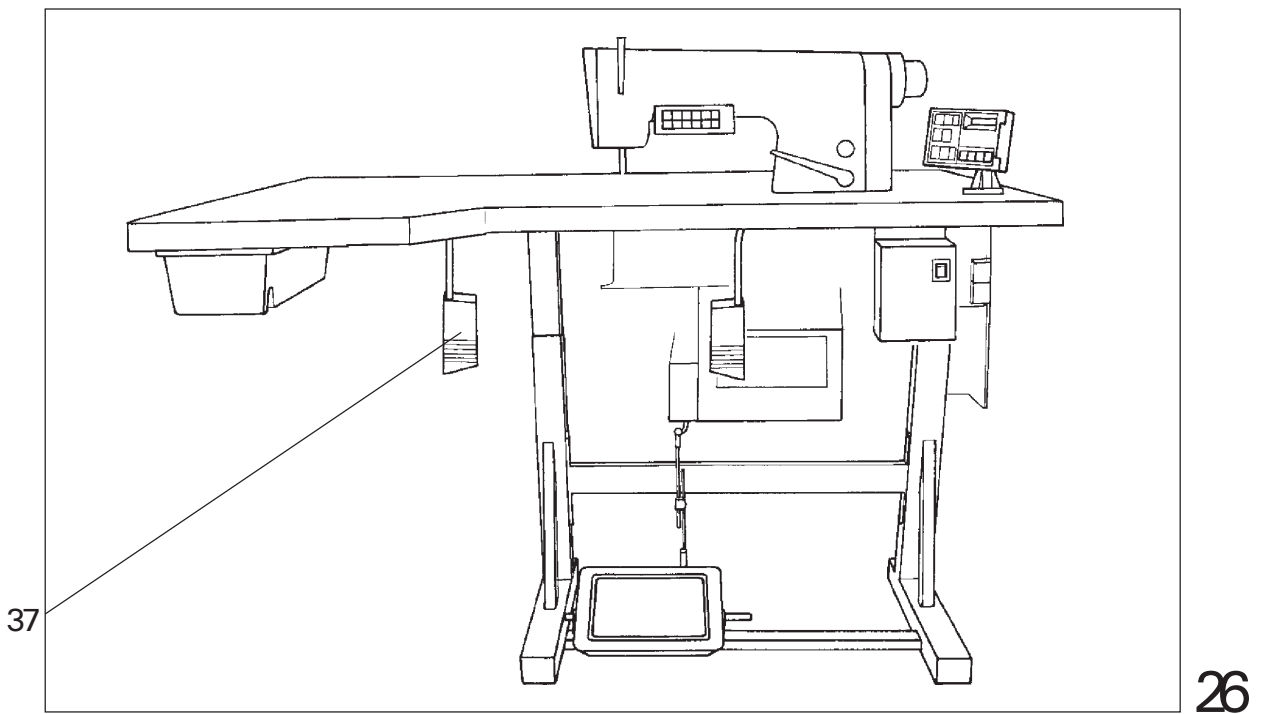
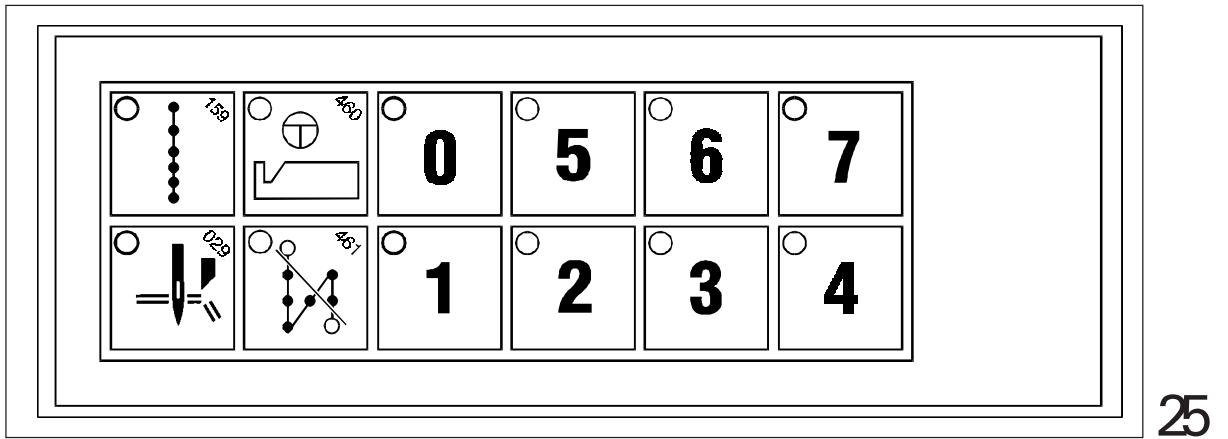
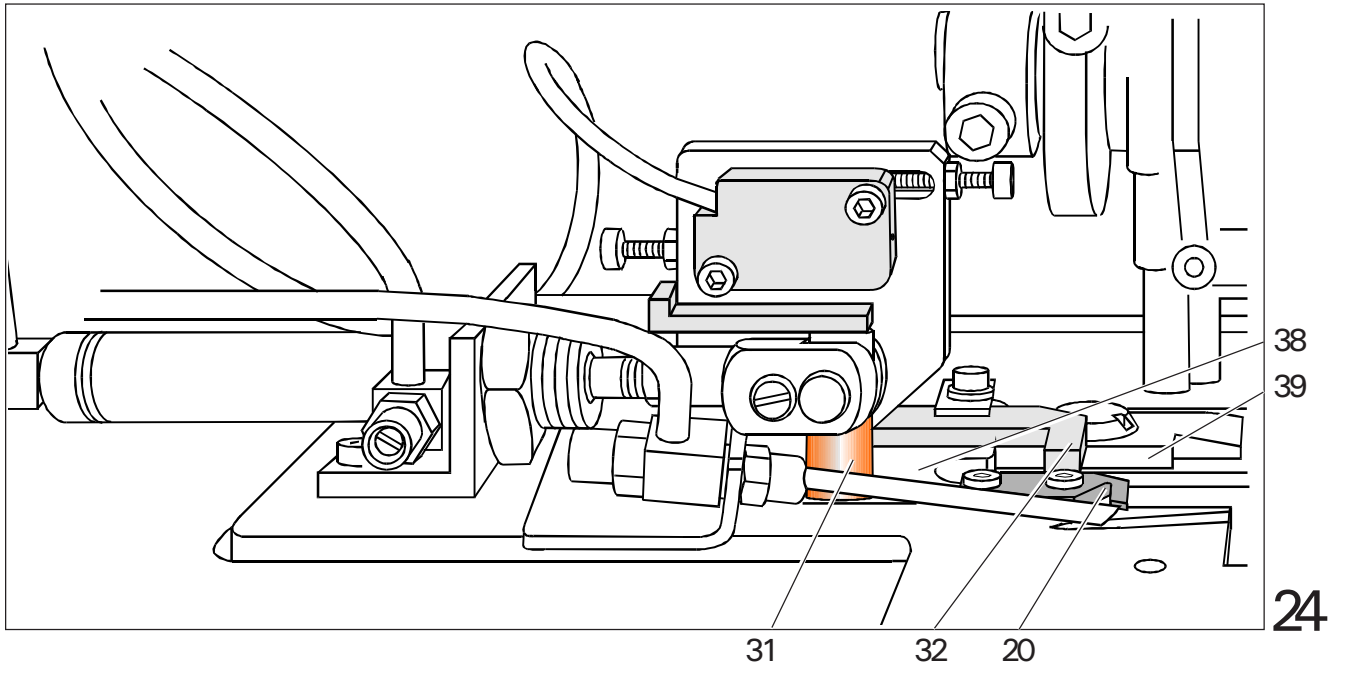

51 Airblast for ply separation (only for -1/24)

Requirement: The fabric plies must be separated enough to allow hook knife 1 (Fig. 1) to pass reliably between the top and bottom plies.

- .1 Set airblast 2 according to requirement.
- .2 Air pressure regulation on throttle valve 3 (Fig. 3).
- .3 Check: switch on airblast, knee switch 4 (Fig. 29).

52 Airblast for cutting waste (only for -1/24)

Requirement: The cutting waste must be reliably extracted into the waste chute.

- .1 Set airblast 5 according to requirement.
- .2 Air pressure regulation on regulator 6.

Note: Airblast only works during sewing action!

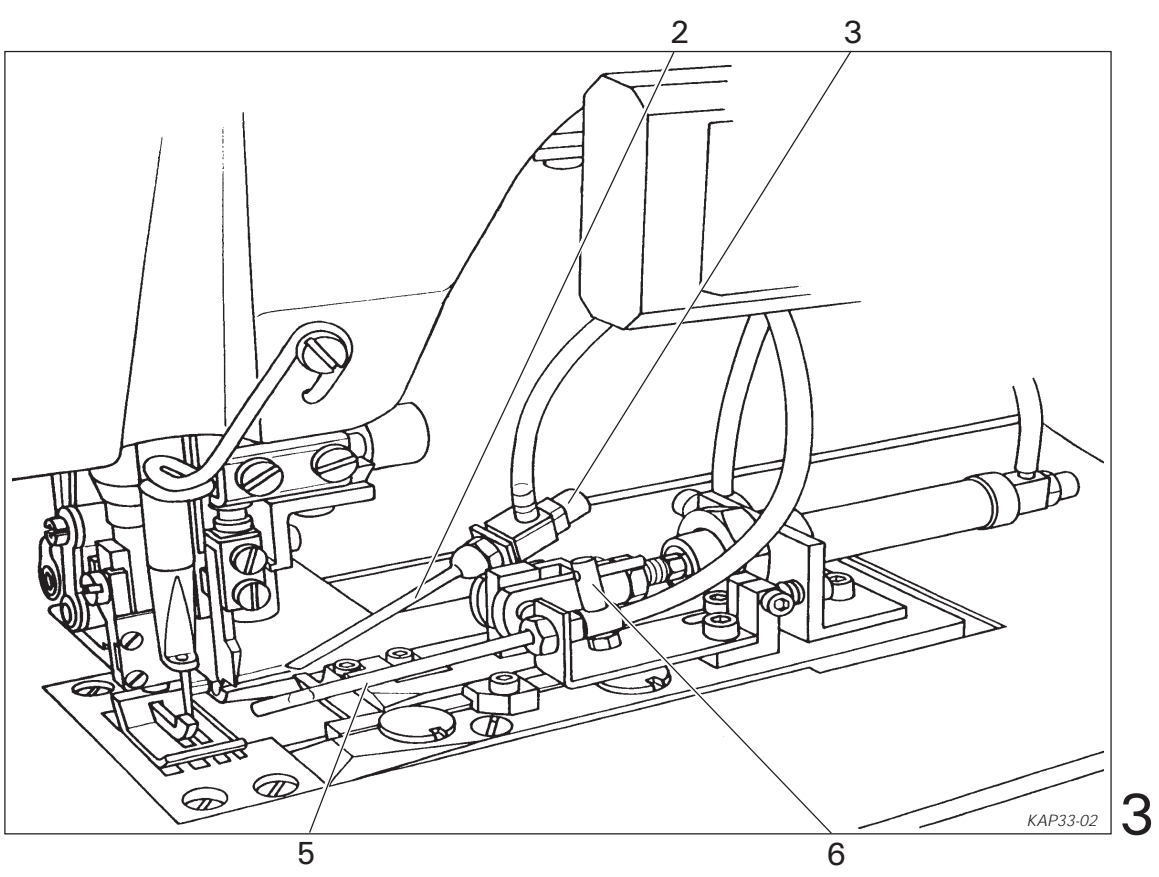
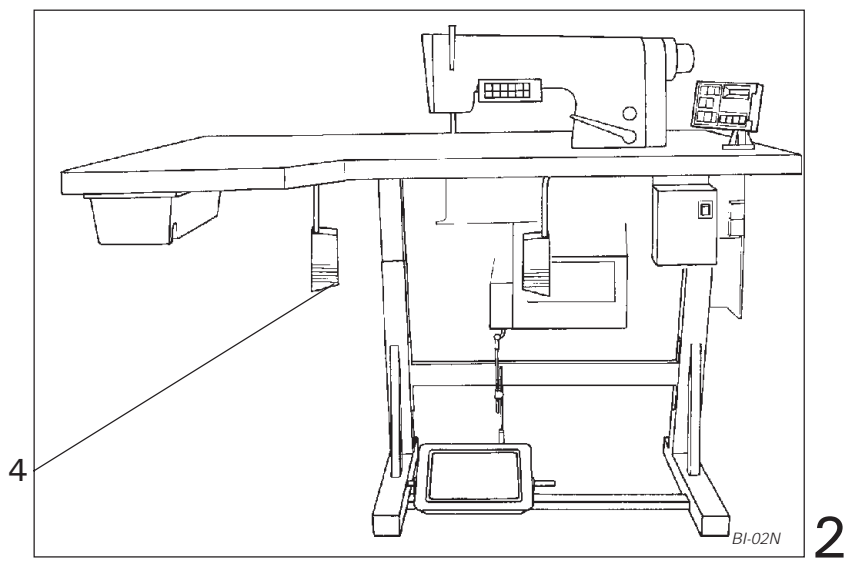
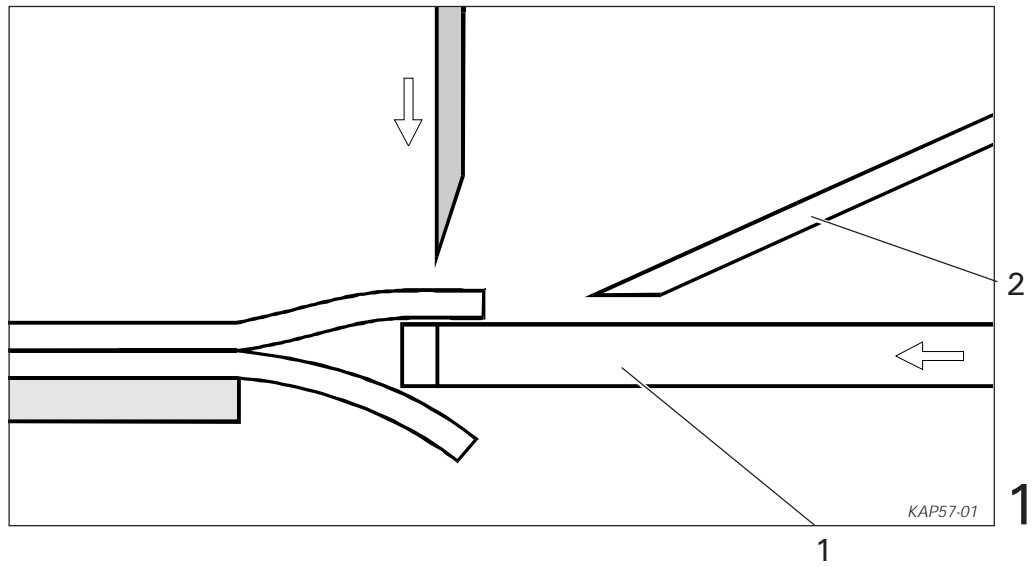



53 Differential quick adjusting device for altering the fullness

53.1 Zeroing the rapid differential adjustment

53.1.1 Rough adjustment on the angle encoder

Requirement: When key  (fig. 1) is activated, pointer 1 (fig. 2) should be in the zero position (5th graduation, fig. 3)

Note: Connecting rod 2 (fig. 2) must be mounted.

- .1  Switch off the machine (master switch).
- .2 Screw off cover plate (above differential quick adjusting device).
- .3 Screw off protective covering of the angle encoder 3.
- .4 Loosen screw 4 a bit.
- .5 Switch on machine (master switch) - key  is automatically activated (LED on).



Note: Make sure not to trap your fingers when making the following adjustments (see arrow in fig. 2)

- .6 Turn the angle encoder 3 until pointer 1 is in the zero position = 5th graduation from the bottom of the scale (fig. 3).
- .7 Tighten up nut 4 in this position.
- .8 - Check (see requirement).
- Screw on the protective cover of the angle encoder.
- Mount cover plate.

53.1.2 Precise adjustment on pot "0"

Requirement: When key  is activated (LED on) the machine should sew without ply shift (without fullness).

- .1 Test seam.
- .2 If necessary readjust pot "0"

Note: The pot "0" (fig. 4) has been set to the "0" position at the factory and should generally not be adjusted or just a little (to correct the rough setting)!



If however the pot "0" should ever be very wrongly adjusted, the basic setting ("0" position of the pot) can be roughly readjusted as follows:

- Turn pot "0" 20 times to the left (direction -)
- Turn pot "0" 14 times to the right (direction +)

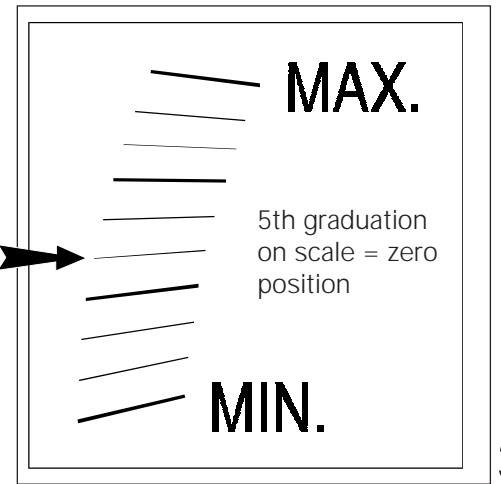
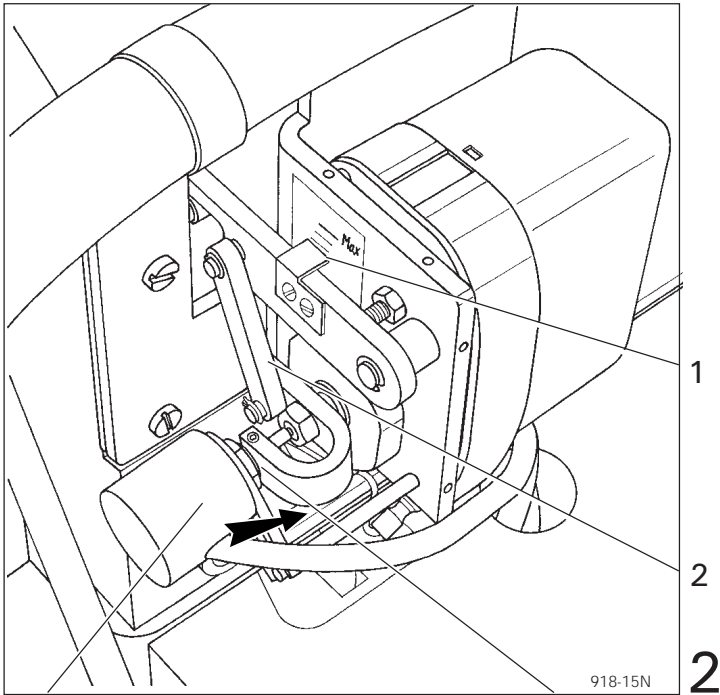
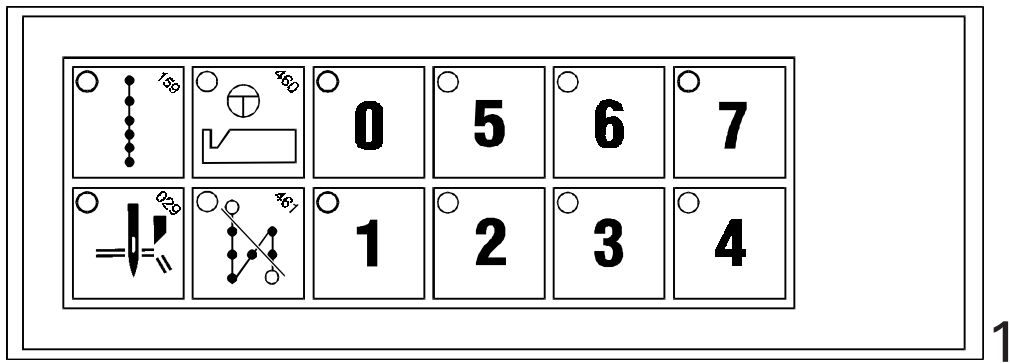

3

4

2

3

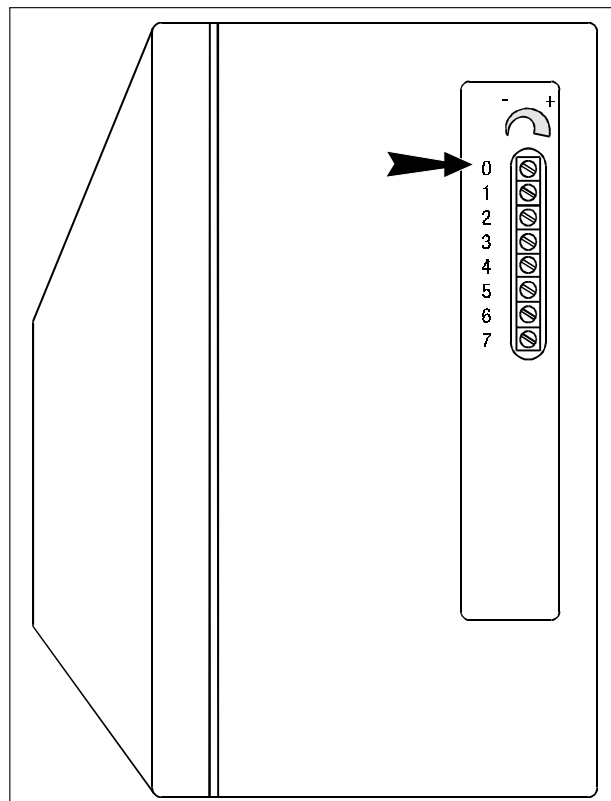

4

53.2 Key arrangement to set pointer 1 (fig. 6)

53.2.1 Keys **0** (no fullness) and **1** to **4** more fullness in the lower ply)

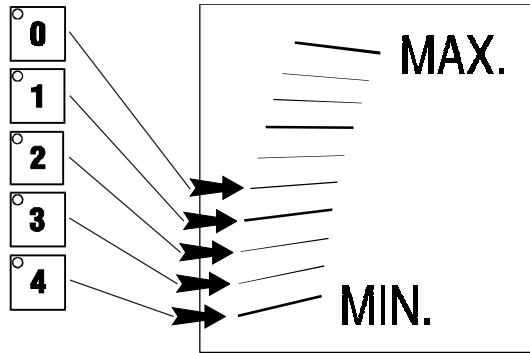

53.2.2. Keys **5** to **7** (fullness in the upper ply)

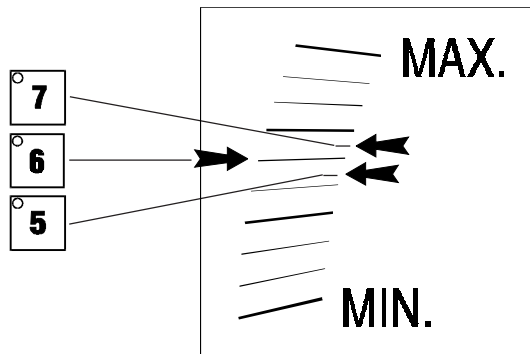

53.3 Basic setting of the fullness quantities of keys **1** - **7**

Each key is allocated to a potentiometer (key **1** /pot "1" etc.)

The basic setting of keys **1** - **7** can be changed by turning the pot concerned.

53.3.1 Adjustment of fullness key **1**

Press key **1**

Keep turning pot "1" until pointer 1 (fig. 6) moves to the 4th scale graduation mark from the bottom (see section 53.2.1)

53.3.2 Adjustment of fullness key **2**

Press key **2**

Keep turning pot "2" until point 1 (fig. 6) moves to the 3rd graduation mark (see section 53.2.1)

The fullness of keys **3** - **7** are adjusted in the same way.

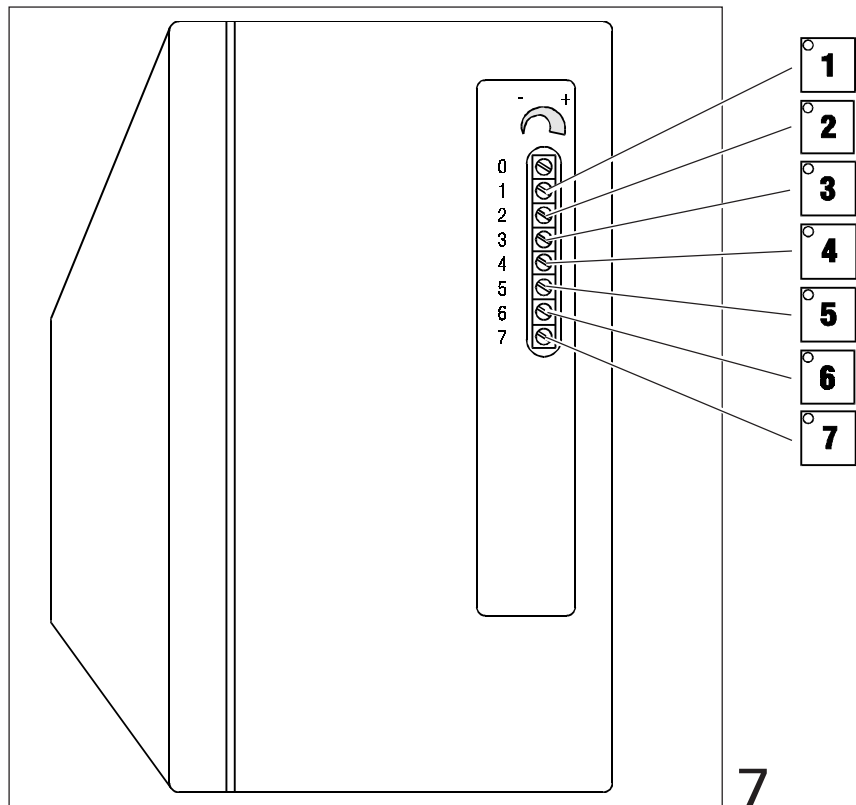
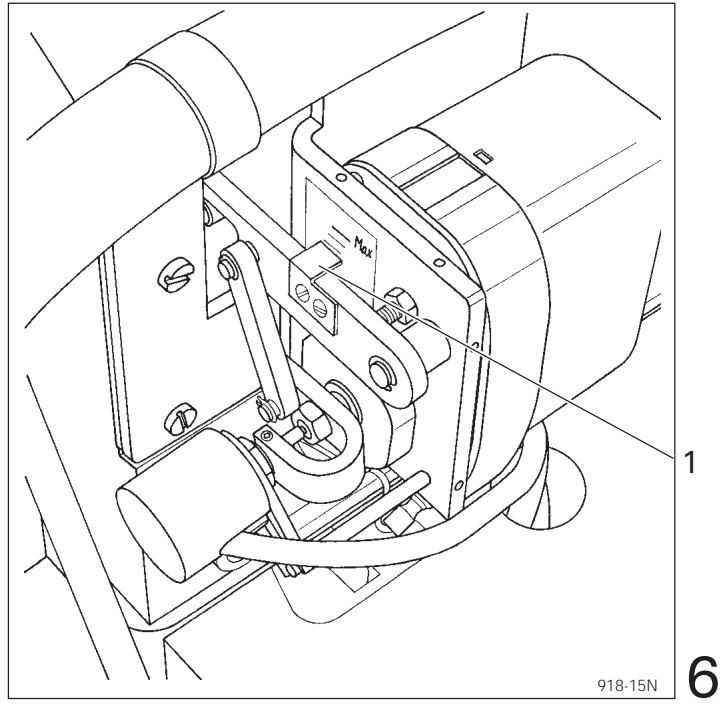
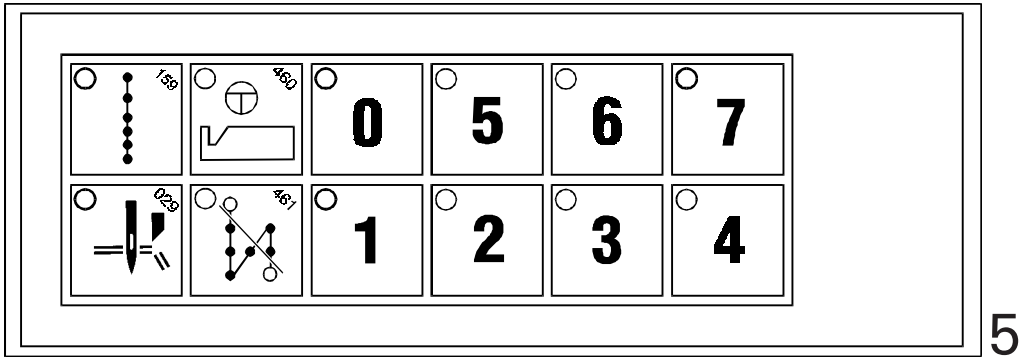

53.4 Feed lever

Requirement: With

- stitch length adjustment " 2.5"
- adjustment link 5 attached (fig. 8)
- and key  pressed

feed lever 6 (fig. 8/11/12) should be in contact with bottom surface of transmission crank 7.

Note: The connecting rod 8 (fig. 10) must be mounted.

- .1 Attach adjustment link 5 (fig. 8).
- .2 Adjust stitch length " 2.5" .
- .3 Switch on machine (master switch):
 - Key  is automatically activated (LED on)
- .4 Loosen screw 9 (fig. 11)
- .5 Bring feed lever 6 (fig 11/12) from below in contact with transmission crank 7.
- .6 Tighten up screw 9(fig. 11).
Make sure that feed lever 6 is resting on the side of the bearing of the reverse feed crank 10!
- .7 Check (see requirement)
- .8 Remove adjustment link 5 (fig. ()).

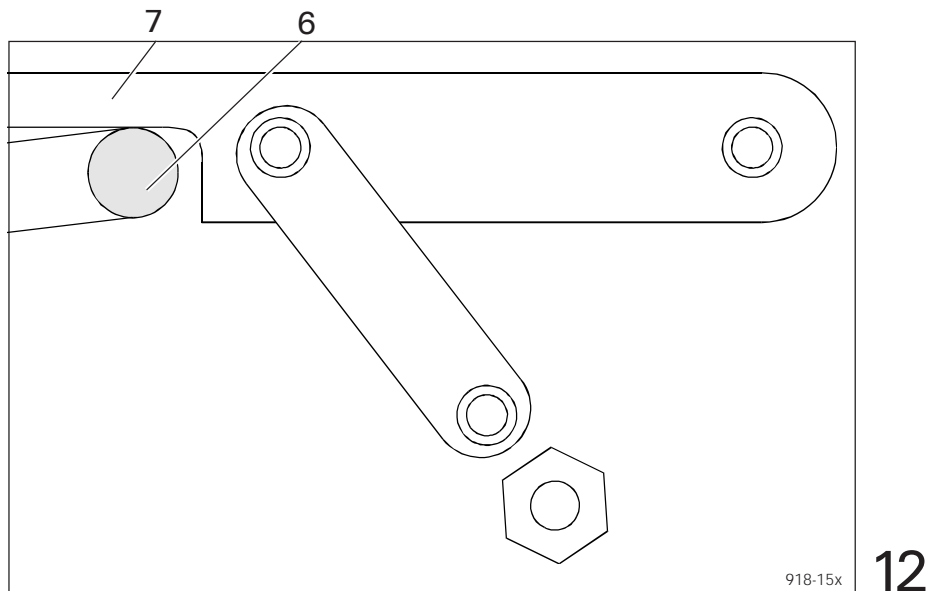
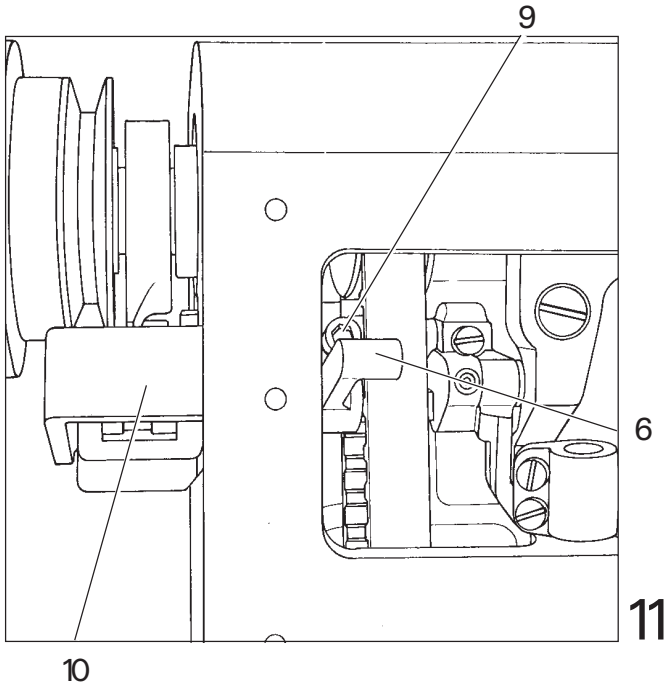
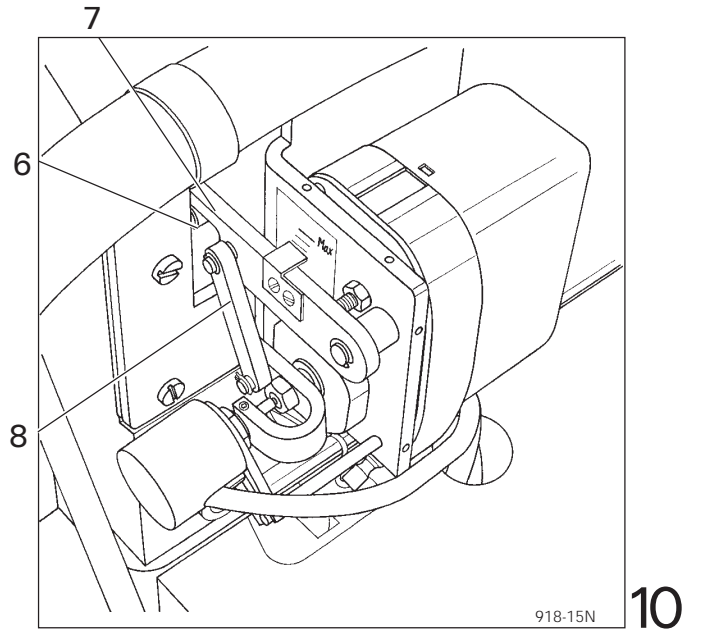
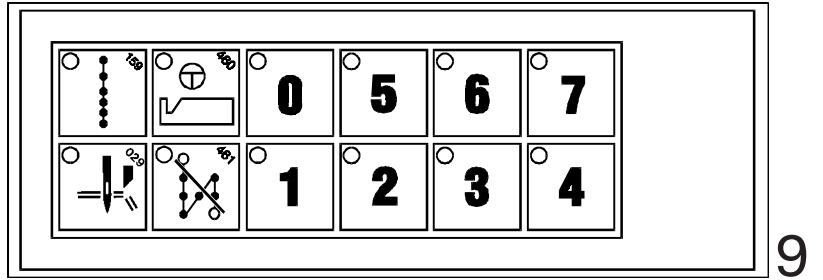
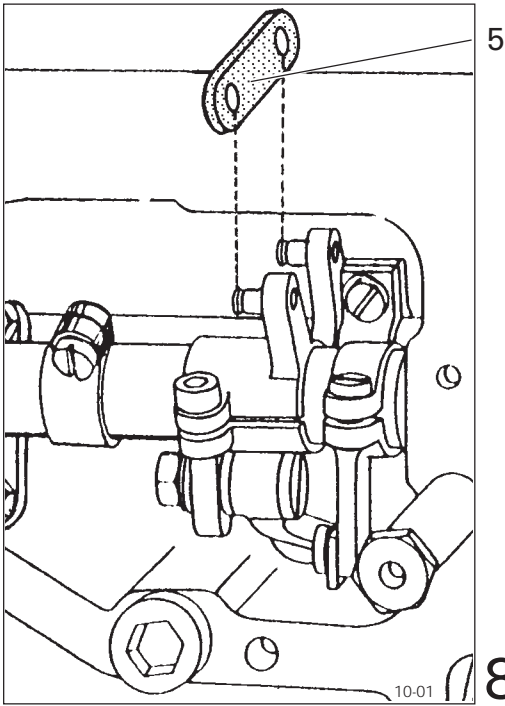





53.5 Examples for the potentiometer adjustment

Requirement: Keys **1**, **2**, **3**, **4**
are for recalling the fullness for the bottom ply.

Keys **5**, **6**, are for recalling the fullness for the top ply.

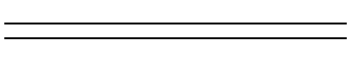
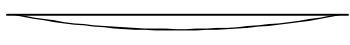
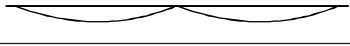
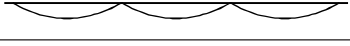
Note: Consider requirement of section 53.3 when adjusting potentiometers "2" to "7".

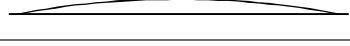
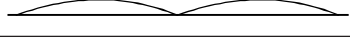
Example with stitch length "2.5"

Key pressed	Movement of bottom feed dog	Movement of upper feed dog	Seam construction
0	2,5 mm	2,5 mm	
1	2,5 mm	2,0 mm	
2	2,5 mm	1,5 mm	
3	2,5 mm	1,0 mm	
4	2,5 mm	0,5 mm	
5	2,5 mm	3,0 mm	
6	2,5 mm	3,5 mm	
7	2,5 mm	4,0 mm	

Test seam:

- .1 Set desired stitch length.
- .2 Switch on machine (mains switch).
- Key **0** is automatically activated (LED on)
- .3 Join two workpieces of the same length (approx. 50 cm) together.
- .4 If the two workpieces are not joined together in a shift-free condition, carry out correction on potentiometer "0" (fig. 14).
- .5 For setting the personally desired fullness assign the individually required fullness amount to keys **1** to **7** by re-adjusting potentiometers "1" to "7".

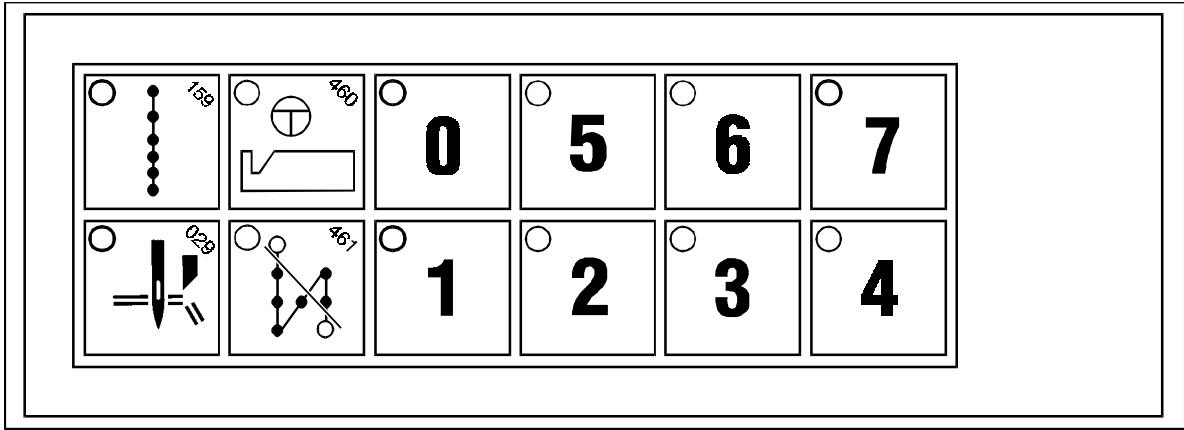

13

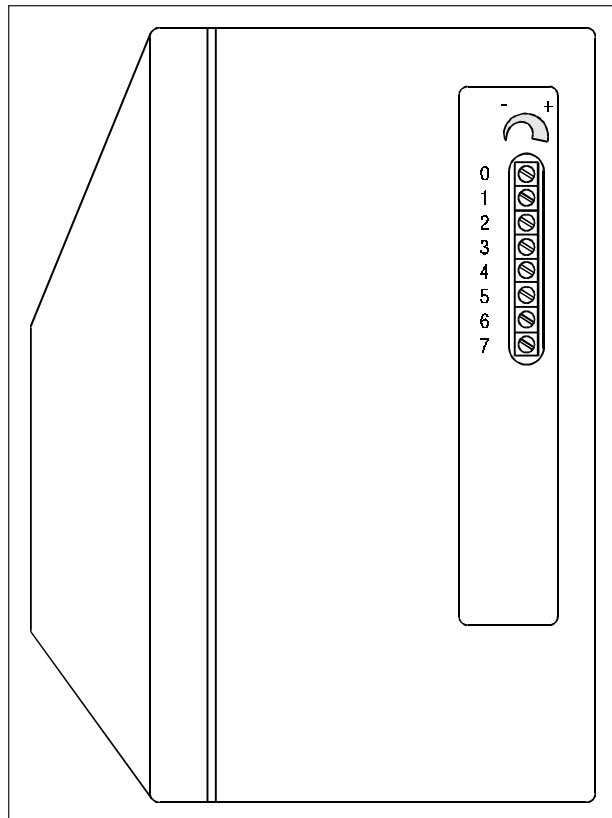

14

54 Care and maintenance

54.1 Sewing machine

.1 Oiling the sewing machine

See capt. 8.1

.2 Cleaning the sewing machine.

- .1 The intervals for cleaning the sewing machine depend on the following factors:
 - Single or multi-shift operation
 - Amount of sewing lint
 - Continuous- or intermittent high-speed operation

Optimum cleaning instructions can therefore only be stipulated for each individual case, in co-operation with the internal maintenance staff and authorized service personnel, under consideration of the above-mentioned factors and the corresponding operating manual.

- .2 In order to avoid disturbances, we recommend the following cleaning intervals:
 - Entire unit, at least once a week
 - Hook area, at least once a day

54.2 Air filter/lubricator

Check daily.

.1 Water trap bowl

For max. water level see arrow in Fig. 1

Empty bowl 1 daily (drain screw 2).

.2 Air filter

Note: Clean filter when working pressure of 6 bar is no longer achieved.

- .1 Disconnect compressed air.
- .2 Remove bowl 1.
- .3 Unscrew washer3.
- .4 Take out filter 4
- .5 Clean filter and bowl with petroleum.
- .6 Blow filter out **from the inside** with compressed air.
- .7 When re-fitting, check for correct seal seat.
- .8 Re-connect compressed air.

54.3 Recommended lubricants

Only use oil with a mean viscosity of 10.0 mm²/sec. at 40°C and a density of 0,847 g/cm³ at 15°C.

We recommend PFAFF sewing machine oil No. 280-1-120 105.



The oil used must have little or no effect on swelling or shrinkage of the sealing materials used under different operating conditions.

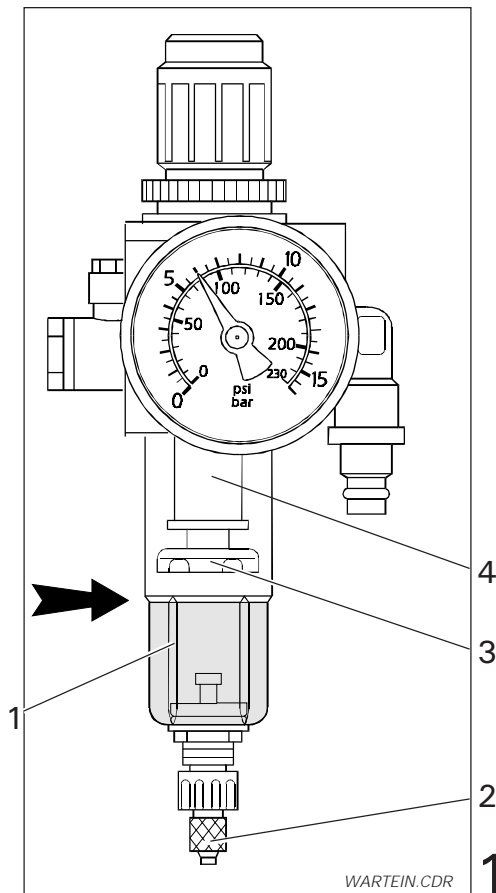

PFAFF

**G.M. PFAFF
Aktiengesellschaft**

Postfach 3020
D-67653 Kaiserslautern

Königstr. 154
D-67655 Kaiserslautern

Telefon: (0631) 200-0
Telefax: (0631) 172 02
Telex: 45753 PFAFF D

Gedruckt in der BRD
Printed in Germany
Imprimé en R.F.A.
Impreso en la R.F.A.
Stampato in R.F.G.
отпечатано ФРГ