

PFAFF

3811-3/55
-15/65
-16/65

Instruction Manual

This instruction manual applies to machines from the following serial numbers onwards:

2710276 →



This Instruction Manual is valid for all models and subclasses listed in the chapter "**Specifications**".

The reprinting, copying or translation of PFAFF Instruction Manuals, whether in whole or in part, is only permitted with our previous authorization and with written reference to the source.

PFAFF Industrie Maschinen AG

Postfach 3020

D-67653 Kaiserslautern

Königstr. 154

D-67655 Kaiserslautern

	Chapter - Page
Contents	Chapter - Page
1 Safety	1 - 1
1.01 Regulations	1 - 1
1.02 General notes on safety	1 - 1
1.03 Safety symbols	1 - 2
1.04 Important notes for the user	1 - 2
1.05 Notes for operating and technical staff	1 - 3
1.05.01 Operating staff	1 - 3
1.05.02 Technical staff	1 - 3
1.06 Danger warnings	1 - 4
2 Proper use	2 - 1
3 Specifications	3 - 1
4 Disposal of Machine	4 - 1
5 Transportation, packing and storage	5 - 1
5.01 Transportation to customer's premises	5 - 1
5.02 Transportation inside the customer's premises	5 - 1
5.03 Disposal of packing materials	5 - 1
5.04 Storage	5 - 1
6 Explanation of symbols	6 - 1
7 Controls	7 - 1
7.01 Main switch	7 - 1
7.02 Pedal	7 - 1
7.03 Presser bar lifter	7 - 2
7.04 Knee Switch	7 - 2
7.05 Edge guide (only on the PFAFF 3811-3/55 and PFAFF 3811-15/65)	7 - 3
7.06 Reverse-feed control lever	7 - 3
7.07 Keyboard	7 - 4
7.08 Control panel	7 - 5
8 Mounting and commissioning the machine	8 - 1
8.01 Mounting	8 - 1
8.01.01 Adjusting the table-top height	8 - 1
8.01.02 Tightening the V-belt	8 - 2
8.01.03 Fitting the upper belt guard	8 - 2
8.01.04 Mounting the bottom V-belt guard	8 - 3
8.01.05 Fitting the synchronizer	8 - 3
8.01.06 Connecting the plug-in connections and earth cables	8 - 4
8.01.07 Fitting the reel stand	8 - 5
8.02 Commissioning	8 - 6
8.03 Switching the machine on/off	8 - 6

	Contents	Chapter - Page
9	Preparation	9 - 1
9.01	Inserting the needle	9 - 1
9.02	Threading the needle thread and regulating its tension	9 - 2
9.03	Threading the looper thread and regulating its tension	9 - 3
9.04	Selecting the program number	9 - 4
9.05	Inputting fullness	9 - 5
9.06	Entering / altering the code number	9 - 6
9.07	Adjusting the control panel	9 - 8
10	Sewing	10 - 1
10.01	Manual sewing	10 - 1
10.01.01	Entering the seam start and seam end in manual sewing mode	10 - 3
10.01.02	Selecting the material type	10 - 4
10.02	Sewing with fixed programs	10 - 5
10.03	Programmed sewing	10 - 7
10.03.01	Program interruption	10 - 9
10.04	Error messages	10 - 9
11	Input	11 - 1
11.01	Seam program input	11 - 2
11.01.01	Basic settings for seam program input	11 - 2
11.01.02	Seam program input with the "Creating/adjusting a program" function	11 - 4
11.01.03	Entering the actual and required length of the seam section	11 - 5
11.01.04	Seam program input with the "Creating/adjusting a program" function	11 - 6
11.01.05	End of seam section input during seam programming	11 - 8
11.02	Examples of how to create a seam program	11 - 10
11.02.01	Example of a seam program input with the "creating/adjusting a program"	
11.02.02	Example of a seam program input using the "teach-in" function	11 - 14
11.03	Seam program administration	11 - 18
12	Care and Maintenance	12 - 1
12.01	Cleaning	12 - 1
12.02	Machine oil level	12 - 2
12.03	Cleaning/lubricating the top feed joints	12 - 2
12.04	Checking/adjusting the air pressure	12 - 3
12.05	Cleaning the air filter of the air-filter/lubricator	12 - 3
13	Adjustment	13 - 1
13.01	Notes on adjustment	13 - 1
13.02	Tools, gauges and other equipment	13 - 1
13.03	Abbreviations	13 - 1
13.04	Control and adjustment aids	13 - 2
13.05	Adjusting the basic machine	13 - 3

Contents	Chapter - Page
13.05.01 Basic position of the machine	13 - 3
13.05.02 Needle to needle hole	13 -
13.05.03 Preliminary adjustment of the needle height	13 - 5
13.05.04 Neutral position of the main feed dog	13 - 6
13.05.05 Neutral position of the differential feed dog	13 - 7
13.05.06 Feeding motion of the main feed dog and the differential feed dog	13 - 8
13.05.07 Lifting motion of the main feed dog and differential feed dog	13 - 9
(only on the PFAFF 3811-3/55)	13 - 9
13.05.08 Lifting motion of the main feed dog	13 - 10
13.05.09 Lifting motion of the differential feed dog	13 - 11
13.05.10 Position of the main and the differential feed dog on the PFAFF 3811-3/55	13 - 12
13.05.11 Position of the main and the differential feed dog on the	13 - 13
PFAFF 3811-15/65 and -16/65	13 - 13
13.05.12 Neutral position of the top feed dog	13 - 14
13.05.13 Front linkage rod to top feed drive	13 - 15
13.05.14 Aligning the presser foot	13 - 16
13.05.15 Feeding motion of the top feed dog	13 - 18
13.05.16 Top feed stroke	13 - 19
13.05.17 Lifting motion of the top feed dog	13 - 20
13.05.18 Stitch length limitation	13 - 21
13.05.19 Basic setting of the differential adjustment mechanism	13 - 22
13.05.20 Setting the standard stitch length (not on the PFAFF 3811-3/55)	13 - 23
13.05.21 Looper avoiding motion	13 - 24
13.05.22 Looper motion	13 - 25
13.05.23 Looper height and looper angle	13 - 26
13.05.24 Looper-to-needle clearance in sewing direction	13 - 28
13.05.25 Looper-to-needle clearance crosswise to sewing direction	13 - 29
13.05.26 Final adjustment of the needle height	13 - 30
13.05.27 Height of rear needle guard	13 - 31
13.05.28 Clearance between rear needle guard and needle	13 - 32
13.05.29 Position of the front needle guard (does not apply to all machines)	13 - 33
13.05.30 Guard of looper-avoiding-motion eccentric	13 - 34
13.05.31 Take- up lever	13 - 35
13.05.32 Basic setting of the needle thread regulator and the thread guide	13 - 36
13.05.33 Looper thread regulator and looper thread take-up	13 - 37
13.05.34 Looper thread puller	13 - 38
13.05.35 Top feed dog and sewing foot pressure	13 - 39
13.06 Adjusting the edge trimming mechanism	13 - 40
13.06.01 Knife stroke	13 - 40
13.06.02 Neutral position	13 - 41
13.06.03 Starting position of the cylinder	13 - 42
13.06.04 Knife height	13 - 43
13.06.05 Knife position crosswise to sewing direction	13 - 44

Contents

	Contents	Chapter - Page
13.07	Parameter settings	13 - 45
13.07.01	Overview of the parameter functions	13 - 45
13.07.02	Example of a parameter input	13 - 46
13.07.03	List of parameters	13 - 47
13.08	Sewing motor errors	13 - 49
13.09	Explanation of the error messages	13 - 50
13.10	Table of inputs	13 - 51
13.11	Table of outputs	13 - 51
13.12	Service menu	13 - 52
13.13	Carry out a cold start	13 - 53
13.14	Internet update of the machine software	13 - 54
14	Wearing parts	14 - 1
15	Circuit diagrams	15 - 1

1 Safety

1.01 Regulations

This machine is constructed in accordance with the European regulations indicated in the conformity and manufacturer's declarations.

In addition to this instruction manual, please also observe all generally accepted, statutory and other legal requirements, including those of the user's country, and the applicable pollution control regulations!

The valid regulations of the regional social insurance society for occupational accidents or other supervisory authorities are to be strictly adhered to!

1.02 General notes on safety

- The machine must only be operated by adequately trained operators and only when the instruction manual has been fully read and understood!
- All notices on safety and the instruction manual of the motor manufacturer are to be read before the machine is put into operation!
- All notes on the machine concerning danger and safety must be observed!
- The machine must be used for the purpose for which it is intended and must not be operated without its safety devices; all regulations relevant to safety must be adhered to.
- When part sets are changed (e.g. needle, presser foot, needle plate, feed dog or bob-bin), during threading, when the workplace is left unattended and during maintenance work, the machine must be disconnected from the power supply by turning off the on/off switch or removing the plug from the mains!
- Daily maintenance work must only be carried out by appropriately trained persons!
- Repairs and special maintenance work must only be carried out by qualified technical staff or persons with appropriate training!
- During maintenance or repairs on the pneumatic system the machine must be disconnected from the compressed air supply! The only exception to this is when adjustments or function checks are carried out by appropriately trained technical staff!
- Work on the electrical equipment must only be carried out by technical staff who are qualified to do so!
- Work on parts or equipment connected to the power supply is not permitted! The only exceptions to this are specified in regulations EN 50110.
- Conversion or modification of the machine must only be carried out under observation of all relevant safety regulations!

- Only spare parts which have been approved by us are to be used for repairs! We draw special attention to the fact that spare parts and accessories not supplied by us have not been subjected to testing nor approval by us. Fitting and/or use of any such parts may cause negative changes to the design characteristics of the machine. We shall not accept any liability for damage caused by the use of non-original parts.

1.03

Safety symbols



Danger!
Special points to observe.



Danger of injury to operating or technical staff!



Caution

Do not operate without finger guard and safety devices. Before threading, changing bobbin and needle, cleaning etc. switch off main switch.

1.04

Important notes for the user

- This instruction manual belongs to the equipment of the machine and must be available to the operating staff at all times.
This instruction manual must be read before the machine is operated for the first time.
- Both operating and technical staff must be instructed on the safety devices of the machine and on safe working methods.
- It is the duty of the user to operate the machine in perfect running order only.
- The user must ensure that none of the safety devices are removed nor put out of working order.
- The user must ensure that only authorized persons operate and work on the machine.

For further information please refer to your PFAFF agency.

1.05 Notes for operating and technical staff

1.05.01 Operating staff

Operating staff are the persons responsible for setting up, operating and cleaning the machine and for removing any disturbances in the sewing area.

The operating staff are obliged to observe the following points, and must:

- always observe the notes on safety in this instruction manual!
- avoid using any working methods which adversely effect the safety of the machine!
- avoid wearing loose-fitting clothing or jewelry such as necklaces or rings!
- also ensure that only authorized persons are allowed near the danger area of the machine!
- immediately report to the user any changes to the machine that may affect its safety!

1.05.02 Technical staff

Technical staff are persons who have been trained in electrical engineering, electronics, pneumatics and mechanical engineering. They are responsible for lubricating, servicing, repairing and adjusting the machine.

The technical staff are obliged to observe the following points, and must:

- always observe the notes on safety in this instruction manual!
- switch off the on/off switch before carrying out adjustment and repair work and ensure it cannot be switched on again unintentionally!
- never work on parts or equipment still connected to the power supply! Exceptions to this are only permissible according to regulations EN 50110;
- disconnected the machine from the compressed air supply when carrying out maintenance or repair work on pneumatic equipment!
Exceptions to this are only permissible for function checks;
- replace all safety covers after carrying out maintenance or repair work!

1.06

Danger warnings



A working area of **1 m** must be kept free both in front of and behind the machine, so that easy access is possible at all times.



Never put your hands in the sewing area during sewing!
Danger of injury by the needle!



While setting or adjusting the machine do not leave any objects on the table nor in the needle plate area! Objects may be trapped or slung out of the machine!

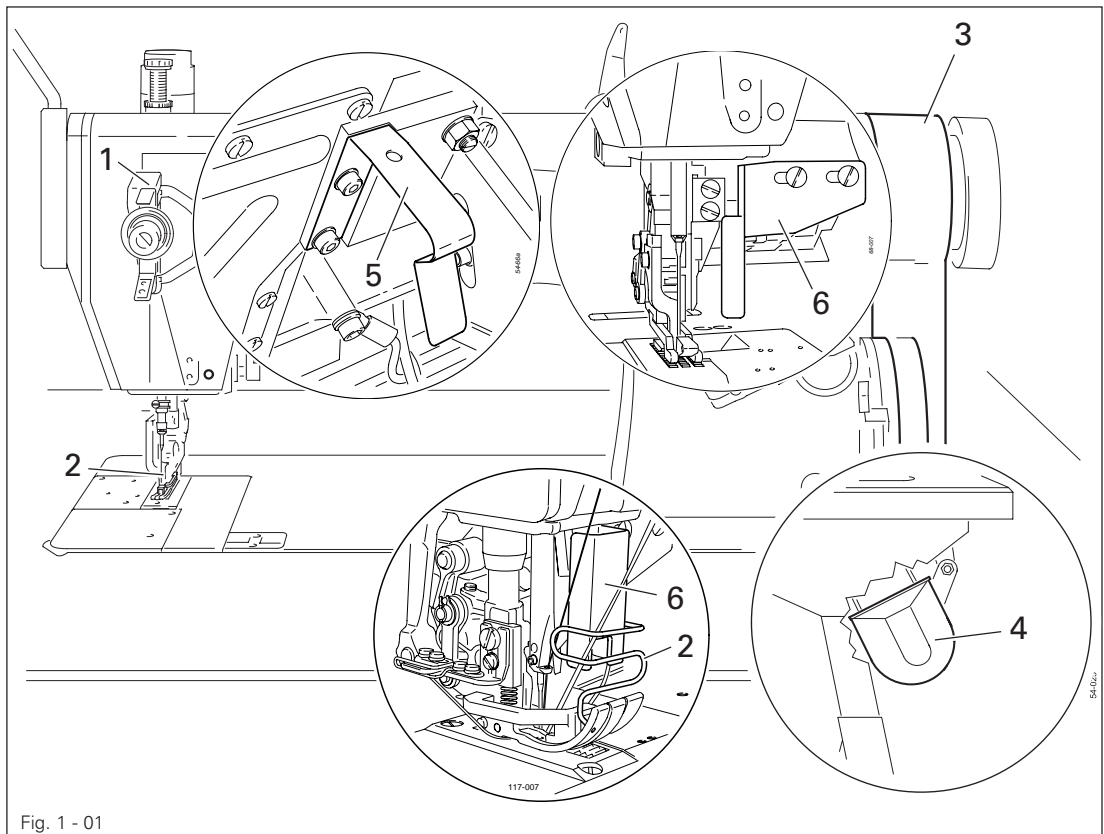

Fig. 1 - 01



Do not operate the machine without take-up lever guard **1!**
Danger of injury from the movement of the take-up lever!



Do not operate the machine without finger guard **2!**
Danger of injury by the needle!



Do not operate the machine without belt guard **3** and **4!**
Danger of injury by running drive belts!



Do not operate the machine without tilt lock **5!**
Danger of crushing between the sewing head and table top!



Do not operate machines with edge trimming device without finger guard **6!**
Do not place fingers in the cutting area between needle plate and knife!
Danger of injury from the cutting motion of the knife!

2 Proper use

The PFAFF 3811-3/55 is an integrated workplace used in the shoe industry for applying fullness to one material ply.

The PFAFF 3811-15/65 is an integrated workplace used in the upholstery industry for the application of fullness in one material ply.

The PFAFF 3811-16/65 is an integrated workplace used in the upholstery industry for the application of fullness in one material ply with the simultaneous trimming of the material edge.



Any use of these machines which is not approved by the manufacturer shall be considered as improper use! The manufacturer shall not be liable for any damage arising out of improper use! Proper use shall also be considered to include compliance with the operation, adjustment, service and repair measures specified by the manufacturer!

3

Specifications[▲]

Stitch type: 401 (two-thread chainstitch)
Max. speed: 3200 stitches/min.♦

Basic stitch length

3811-3/55: 2,2 mm
3811-15/65; 3811-16/65: 3,0 + 4,0 mm

Differential feed stroke

3811-3/55: 2,2 - 6,5 mm
3811-15/65; 3811-16/65: 4,0 - 8,0 mm

Needle system

3811-15/65; 3811-16/65: 4463-35
3811-3/55: 4463-KKD
Needle size in 1/100 mm: 80 - 110

Presser foot clearance:

3811-3/55: 7 mm
3811-15/65, 3811-16/65: 11 mm

Connection data:

Operating voltage: 230 V ± 10%, 50/60 Hz, alternating voltage
Max. power: 400 VA
Fuse protection: 1 x 16 A, inert

Working air pressure: 6 bar
Air consumption: 0.3 - 0.5 l/work cycle

Noise data:

Emission sound pressure level at the workplace with
a sewing speed of 2600 spm: $L_{pA} < 79$ dB(A) ■
(Noise measurement in accordance with DIN 45 635-48-A-1, ISO 11204, ISO 3744, ISO 4871)

Machine dimensions:

Length: approx. 1250 mm
Width (value for 3811-14/71 in brackets) approx. 600 mm (approx. 800 mm)
Height (with reel stand): approx. 1700 mm

Weight (net). Approx. 140 kg

▲ Subject to alterations

♦ Dependent on material, work cycle and stitch length

■ $K_{pA} = 2,5$ dB

4

Disposal of Machine

- Proper disposal of the machine is the responsibility of the customer.
- The materials used for the machine are steel, aluminium, brass and various plastic materials.
The electrical equipment comprises plastic materials and copper.
- The machine is to be disposed of according to the locally valid pollution control regulations; if necessary, a specialist is to be commissioned.



Care must be taken that parts soiled with lubricants are disposed of separately according to the locally valid pollution control regulations!

Transportation, packing and storage

5 Transportation, packing and storage

5.01 Transportation to customer's premises

All machines are delivered completely packed.

5.02 Transportation inside the customer's premises

The manufacturer cannot be made liable for transportation inside the customer's premises nor to other operating locations. It must be ensured that the machines are only transported in an upright position.

5.03 Disposal of packing materials

The packing materials of this machine comprise paper, cardboard and VCE fibre. Proper disposal of the packing material is the responsibility of the customer.

5.04 Storage

If the machine is not in use, it can be stored as it is for a period of up to six months, but it should be protected against dust and moisture.

If the machine is stored for longer periods, the individual parts, especially the surfaces of moving parts, must be protected against corrosion, e.g. by a film of oil.

6 Explanation of symbols

In this instruction manual, work to be carried out or important information is accentuated by symbols. These symbols have the following meanings:



Note, information



Cleaning, care



Lubrication

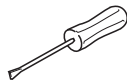

Maintenance, repairs, adjustment, service work
(only to be carried out by technical staff)

7 Controls

7.01 Main switch

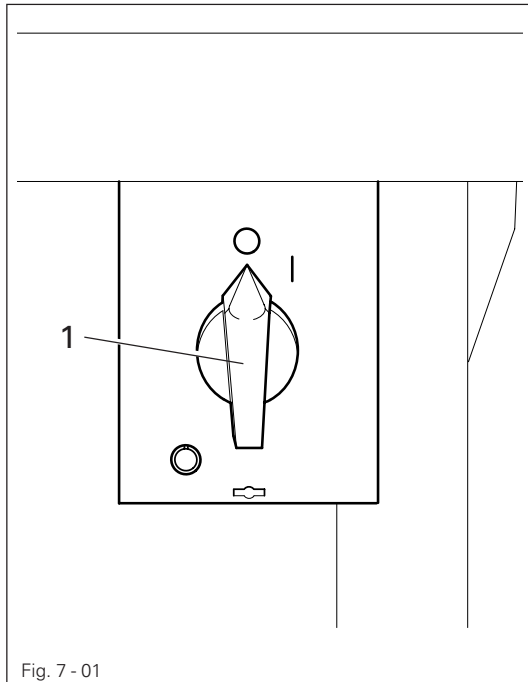

Fig. 7 - 01

- The machine is switched on or off by turning main switch 1.

7.02 Pedal

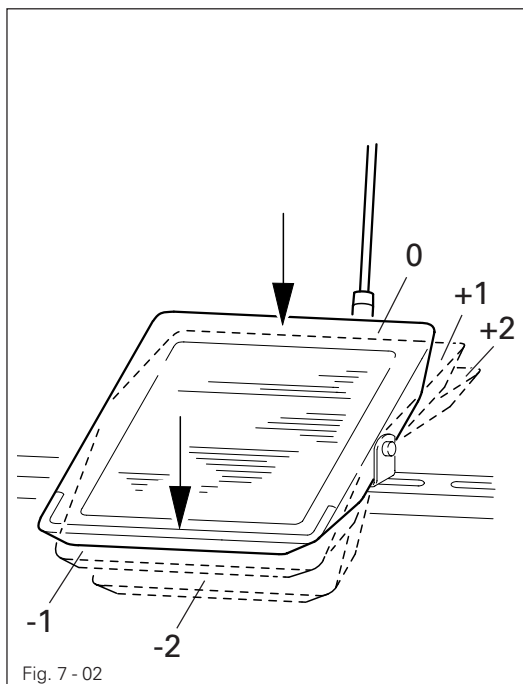
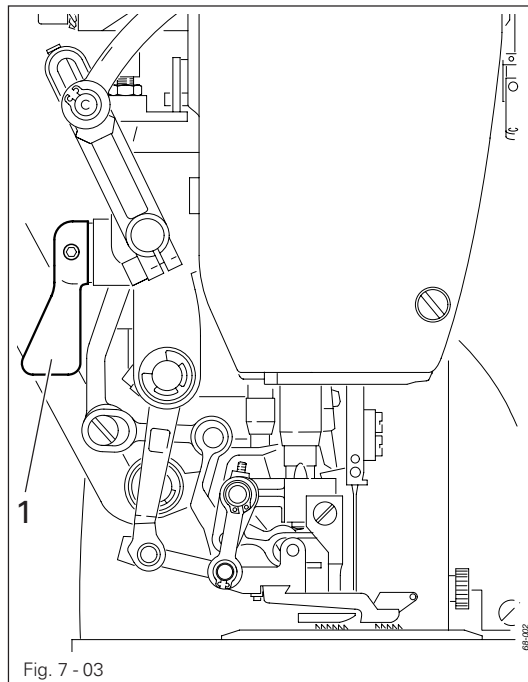

Fig. 7 - 02

- 0 = Neutral position
- +1 = Lower presser foot / Feed bridle tape
- +2 = Sewing
- 1 = Raise presser foot
- 2 = Thread cutting (optional) / needle raised / edge knife out (when parameter 210 is set at "ON", see Chapter 13.07 Parameter settings)

7.03 Presser bar lifter



- The presser foot is raised by turning lever 1.

7.04 Knee Switch

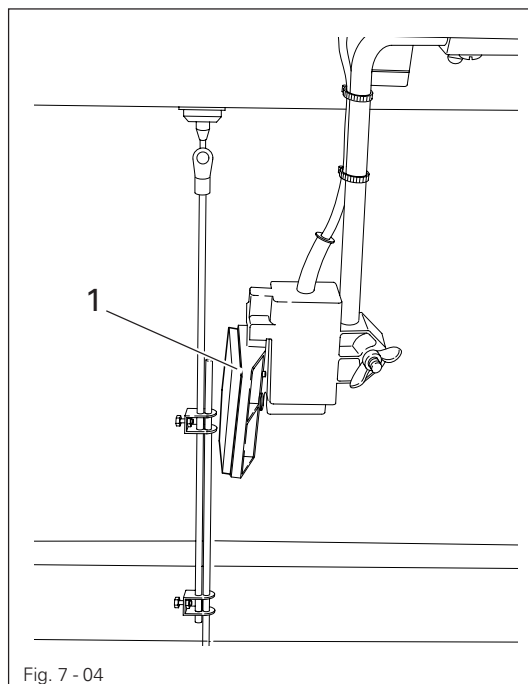

When sewing with fixed programs:

- By operating knee switch 1 it is possible to alternate between two pre-set amounts of fullness.

In programmed sewing:

- By operating knee switch 1 the amounts of fullness are changed according to the program selected.

7.05

Edge guide (only on the PFAFF 3811-3/55 and PFAFF 3811-15/65)

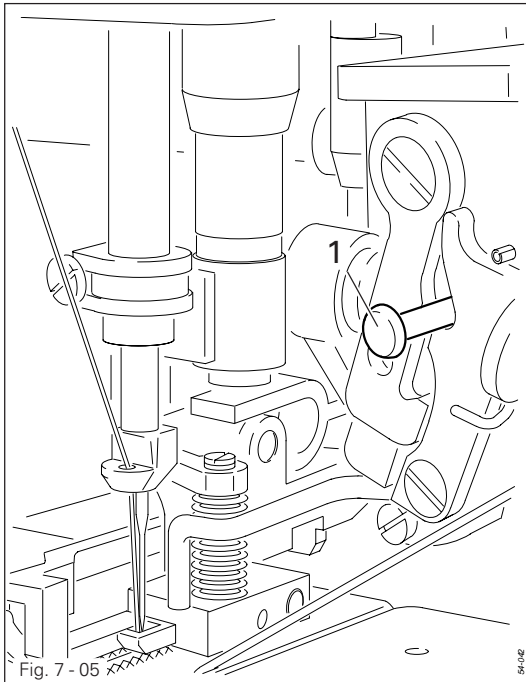

- By pressing down lever 1 the edge guide is engaged.
- By raising lever 1 the edge guide is disengaged.

7.06

Reverse-feed control lever

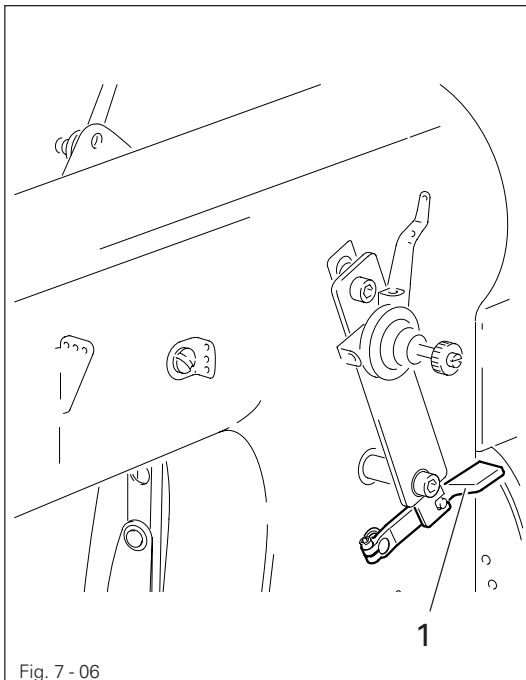

- To sew condensed stitches, press lever 1 down.

7.07 Keyboard

The keyboard 1 is used for quick operation of the machine during sewing. An individual amount of fullness can be allocated to each key, see **Chapter 9.05 Inputting fullness**. Activated key functions are shown with the respective LED of the 20 keys (function activated - LED on).

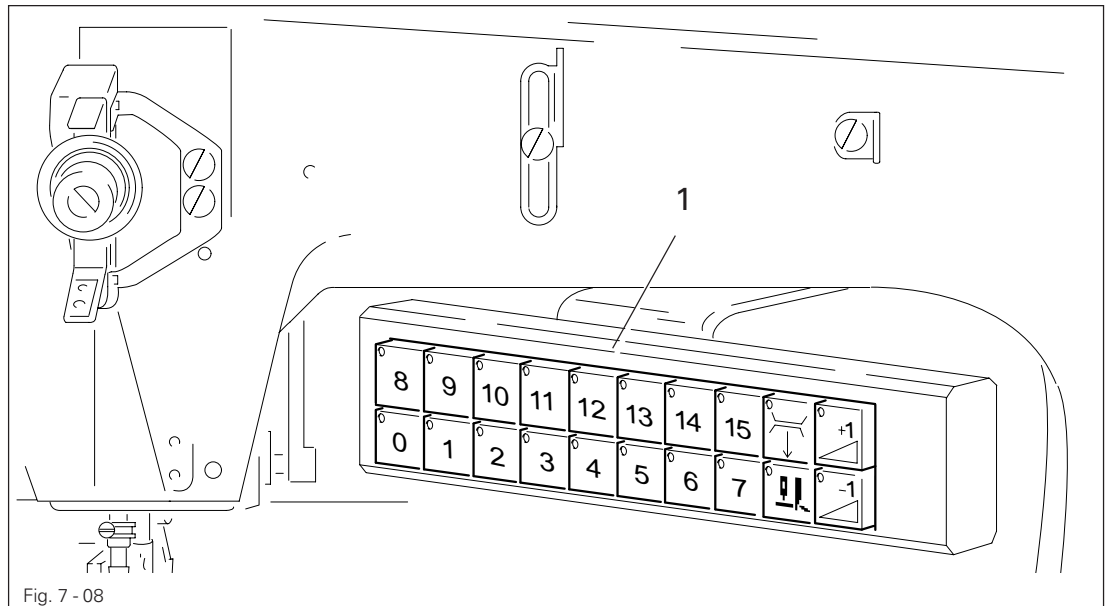

Number keys (0 – 15)

- The previously allocated amount of fullness is called up by pressing a key.
- By simultaneously pressing two neighbouring number keys, the corresponding average amount is selected.



In the basic setting of the keyboard, the set fullness is divided from "0" to "max." in 15 steps. The basic setting is set e.g. after a cold start, see **Chapter 13.13 Carry out a cold start**.



Tape brake(option)

- By pressing a key, the tape brake is engaged or disengaged.
When the tape brake is engaged, the gathering of the material is increased.



Edge trimming mechanism

- By pressing a key the edge trimming mechanism is engaged or disengaged.



Corrective value + / corrective value –

- By pressing a key the fullness value is increased or reduced in 2 steps.

7.08

Control panel

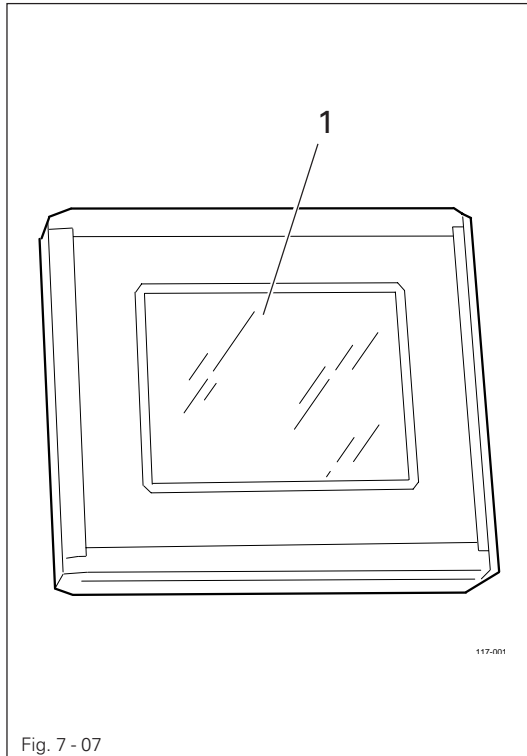

The current operating conditions are displayed on control panel 1. Operation takes place in a constant dialogue between the control unit and the operator. For this purpose, depending on the operating condition of the machine, different symbols and/or texts are displayed. If the symbols or texts are framed, these show functions which can be selected by pressing the appropriate position on the monitor. By pressing the corresponding function this is carried out or switched on or off immediately, or a further menu appears, e.g. for entering a value. Activated functions are shown with inverted symbols. Unframed symbols or texts are only used for display purposes and cannot be selected by pressing.

8 Mounting and commissioning the machine



The machine must only be mounted and commissioned by qualified personnel!
All relevant safety regulations are to be observed!



If the machine is delivered without a table, you must make sure that the frame and the table top which you intend to use can hold the weight of the machine and the motor. It must be ensured that the supporting structure is sufficiently sturdy, including during all sewing operations.

8.01 Mounting

The necessary supply connections for the electrical and pneumatic systems must be available at the machine's location, see **Chapter 3 Specifications**.

There must be a stable and horizontal surface and adequate lighting at the machine's location.



The method of packaging used requires that the table top be lowered for transport. The following is a description of how to adjust the height of the table top.

8.01.01 Adjusting the table-top height

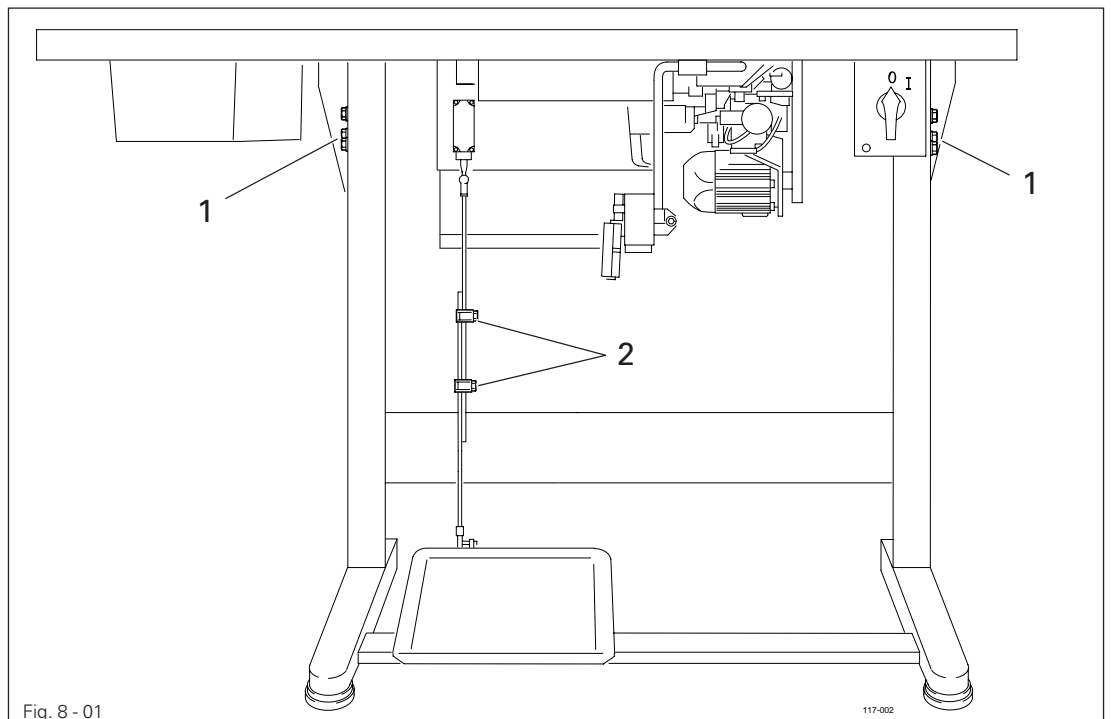

- Loosen screws 1 and 2 and set the desired table-top height.
- Tighten screws 1 well.
- Adjust the position of the pedal so that you can operate it comfortably and tighten screw 2.

Mounting and commissioning the machine

8.01.02 Tightening the V-belt

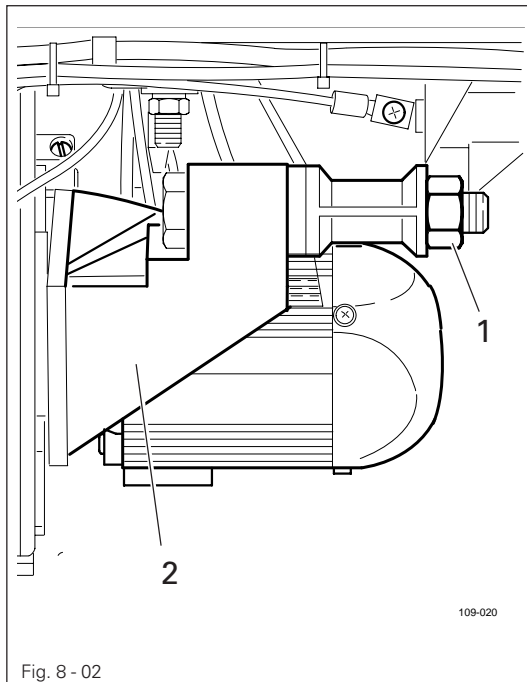

- Fit the V-belt.
- Loosen nut 1 and tighten the V-belt by turning motor mounting 2.
- Tighten nut 1.

8.01.03 Fitting the upper belt guard

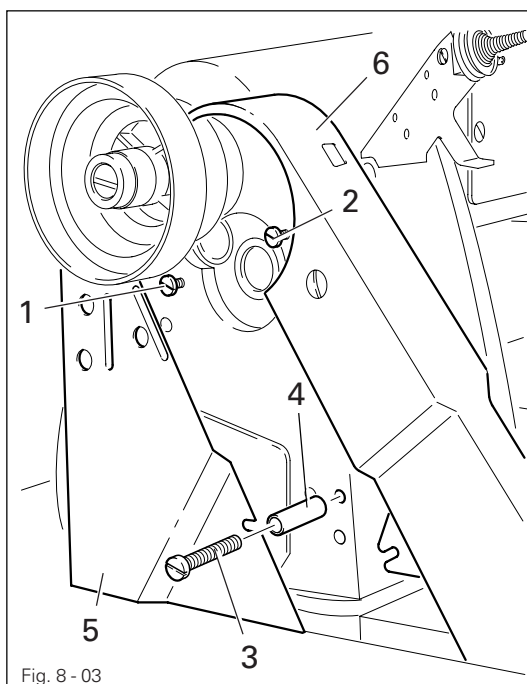

- Insert screws 1 and 2.
- Insert screw 3 with spacing sleeve 4.
- Slide belt guard section 5 so that the slots are behind the heads of screws 1 and 3.
- Slightly tighten screw 1.
- Making sure that the lug of belt guard section 6 is located between belt guard section 5 and the spacing sleeve 4, align the complete belt guard and tighten screws 1, 2 and 3.

8.01.04 Mounting the bottom V-belt guard

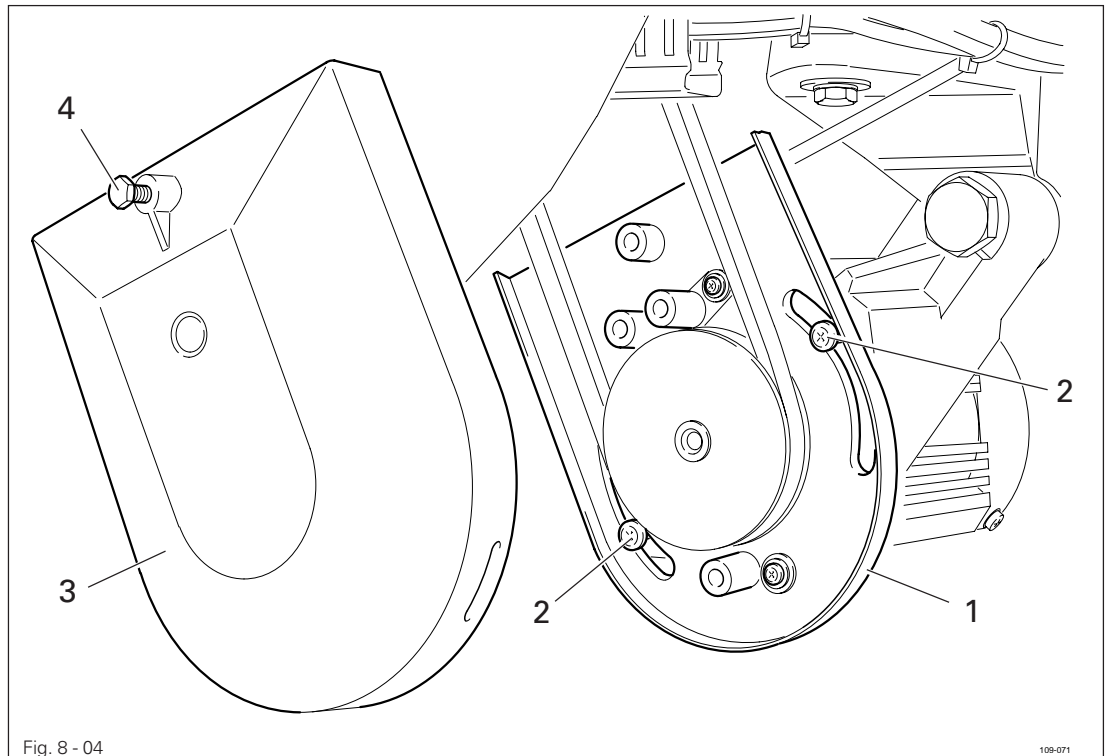

- Loosen screws 2 and adjust belt guard support 1 so that the motor pulley and V-belt run freely.
- Tighten screws 2.
- Fasten belt guard 3 with screw 4.

8.01.05 Fitting the synchronizer

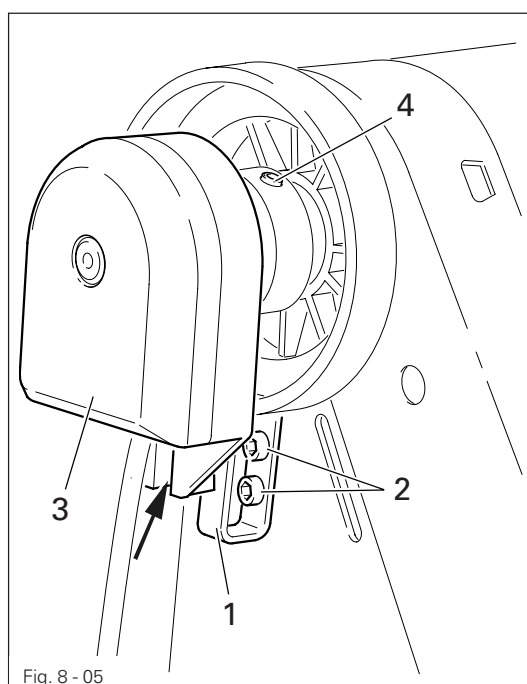

- Screw on stop 1 with screws 2.
- Place synchronizer 3 on the shaft so that stop 1 is in the slot of synchronizer 3, see arrow.
- Tighten screws 4 just a little.
- Insert the plug for the synchronizer in the socket on the control box.
- Adjust synchronizer 3 (see Chapter 13.05.01, Basic position of the machine).

Mounting and commissioning the machine

8.01.06 Connecting the plug-in connections and earth cables

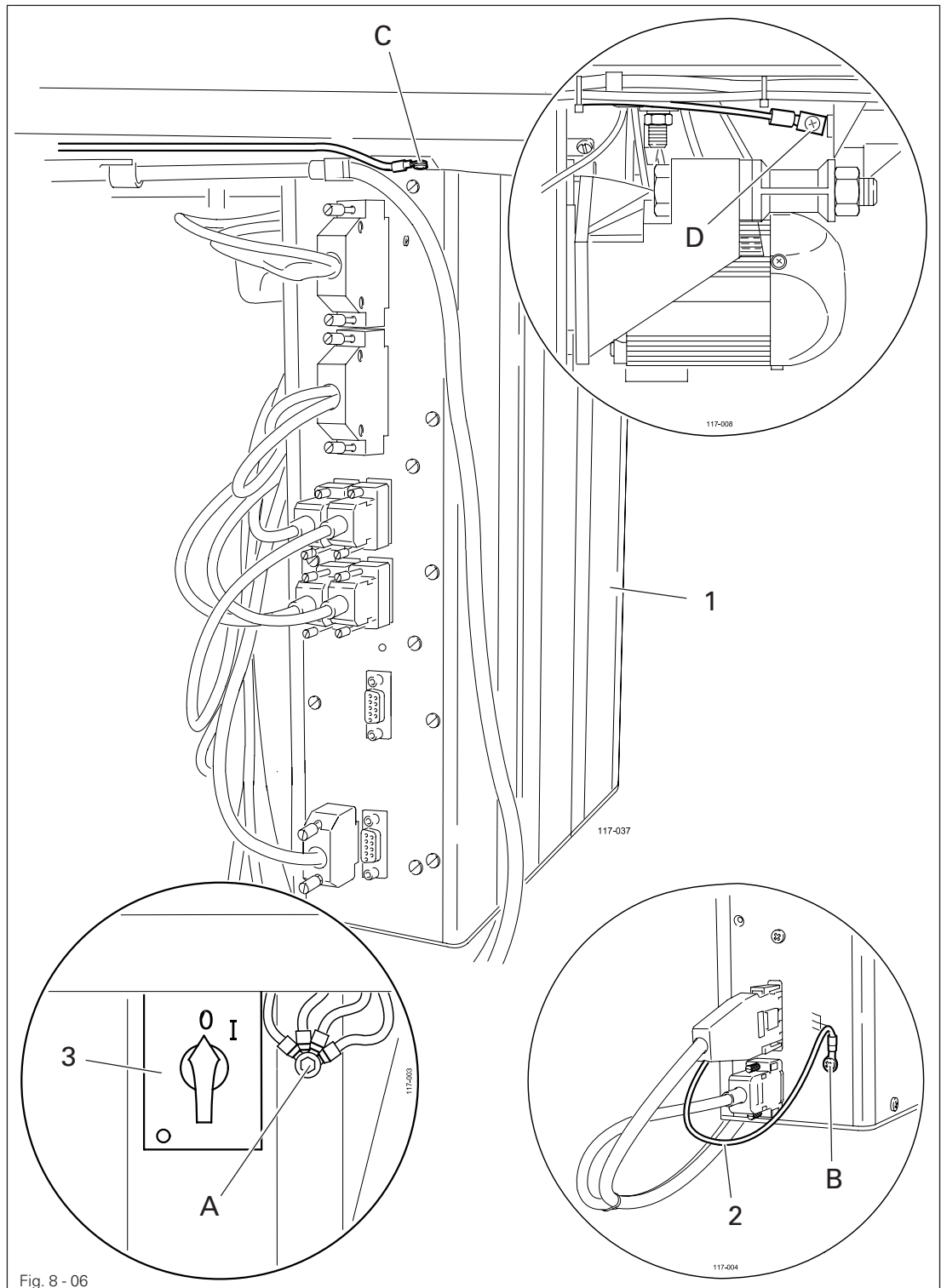
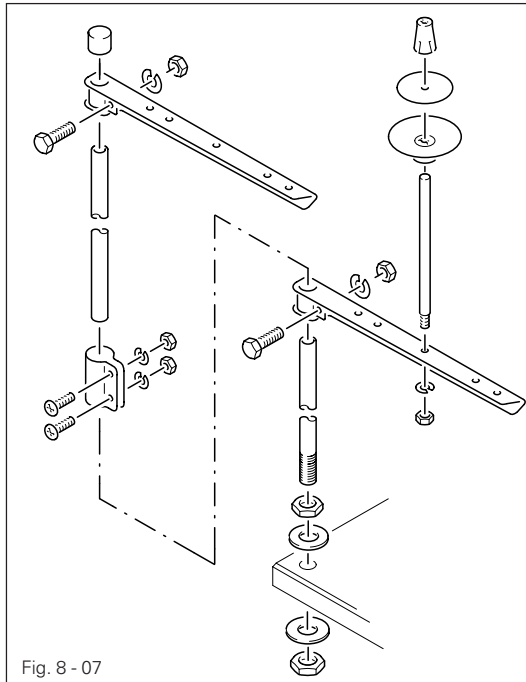

Fig. 8 - 06

- Connect all plugs as labelled in the control box 1.
- Screw the earth cable from the sewing head to earth point A.
- Connect earth point C and earth point A with an earth cable.
- Screw the earth cable from main switch 3 to earth point A.
- Screw the earth cable 2 from the motor to earth point B.

8.01.07 Fitting the reel stand



- Fit the reel stand as shown in **Fig. 8 - 07**.
- Afterwards insert the stand in the hole in the table top and secure it with nuts provided.

8.02

Commissioning

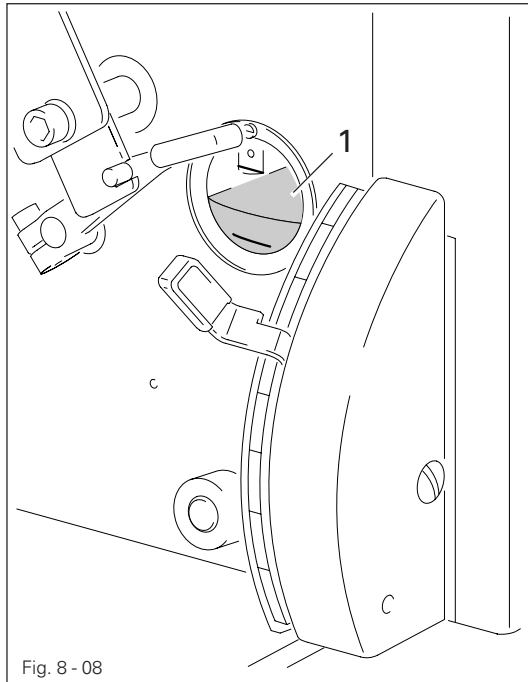

Before setting up, remove the protective foil from oil glass 1!

- Clean the machine thoroughly and afterwards check the oil level (see **Chapter 12, Care and Maintenance**).
- Check the machine for any damage, especially the electrical leads.
- Have a qualified person check whether the motor can be driven with the existing power voltage.



If there are any differences, the machine must definitely not be operated!



The machine must only be connected to a suitably earthed socket!

- When the machine is running, the balance wheel must turn towards the operator. If this is not the case, have the motor adjusted by specialist staff, see **Chapter 13.07 Parameter settings**.
- Machines with pneumatic equipment have to be connected to the compressed air supply. The pressure gauge must show a pressure of **6 bar**. If necessary have this reading adjusted (see **Chapter 12.04, Checking/adjusting the air pressure**).

8.03

Switching the machine on/off

- Switch the machine on or off, see **Chapter 7.01 Main switch**.
- Carry out a test run.

9 Preparation



All regulations and instructions in this Instruction Manual are to be observed!
Special attention is to be paid to the safety regulations!



All preparation work is only to be carried out by appropriately trained personnel.
Before all preparation work, the machine is to be separated from the electricity supply by removing the plug from the mains or switching off the On/Off switch!

9.01 Inserting the needle

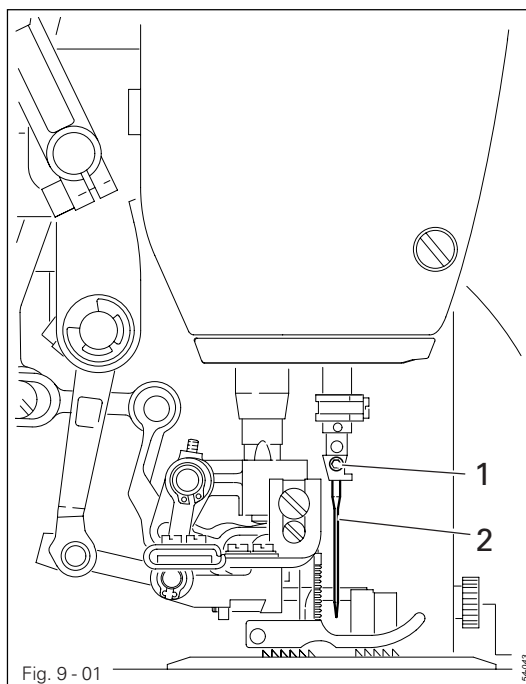

Switch off the machine!
Danger of injury by unintentional starting of the machine!



Only use needles from the system intended for the machine, see Chapter 3 Specifications.

- Set the needle bar at its highest point.
- Loosen screw 1.
- Push needle 2 fully into the needle bar (the long needle groove must face to the front).
- Tighten screw 1.

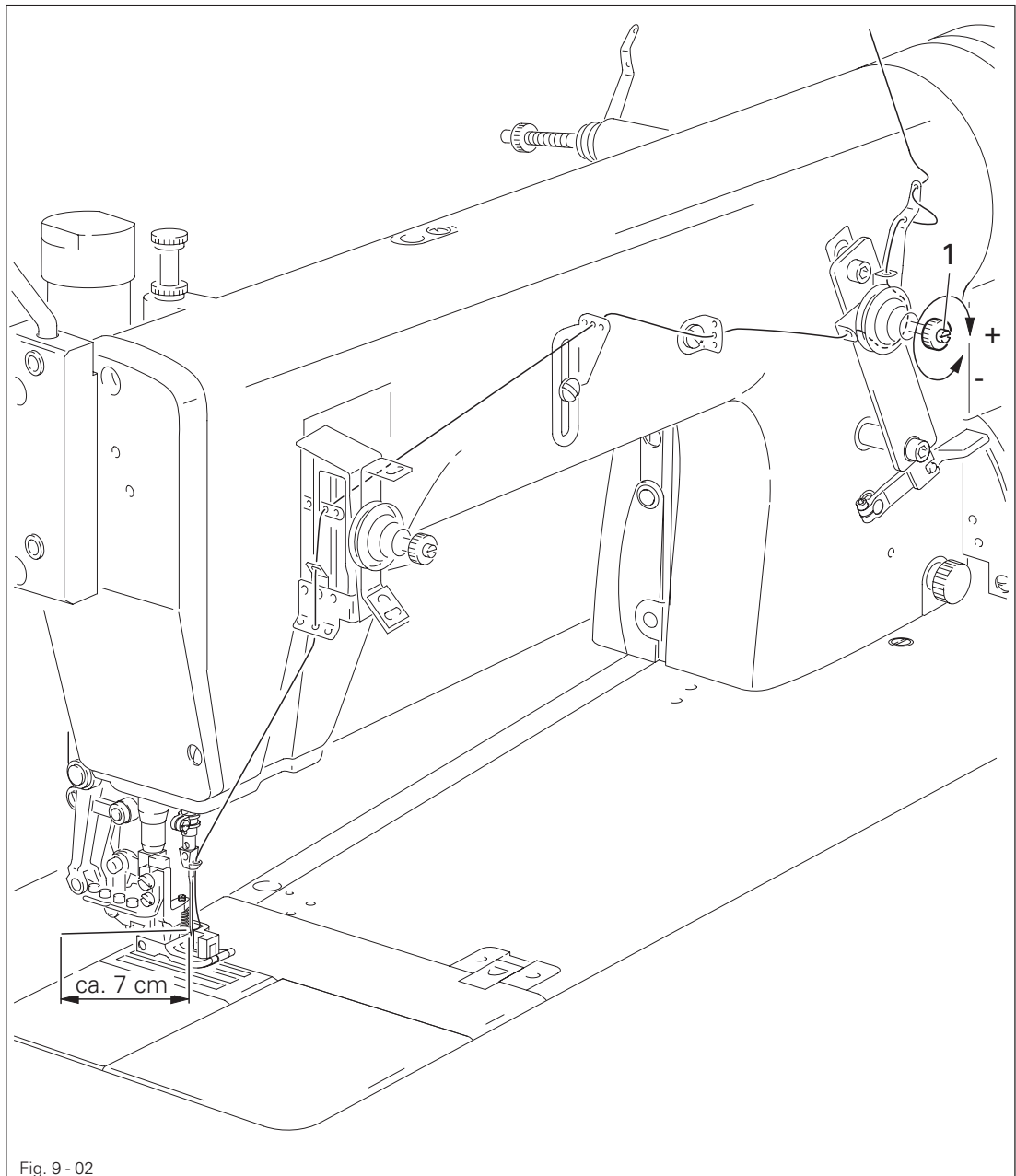

Switch off the machine!

Danger of injury by unintentional starting of the machine!

- Thread the needle thread as shown in Fig. 9-02.
- Regulate the needle thread by turning knurled screw 1.

9.03 Threading the looper thread and regulating its tension

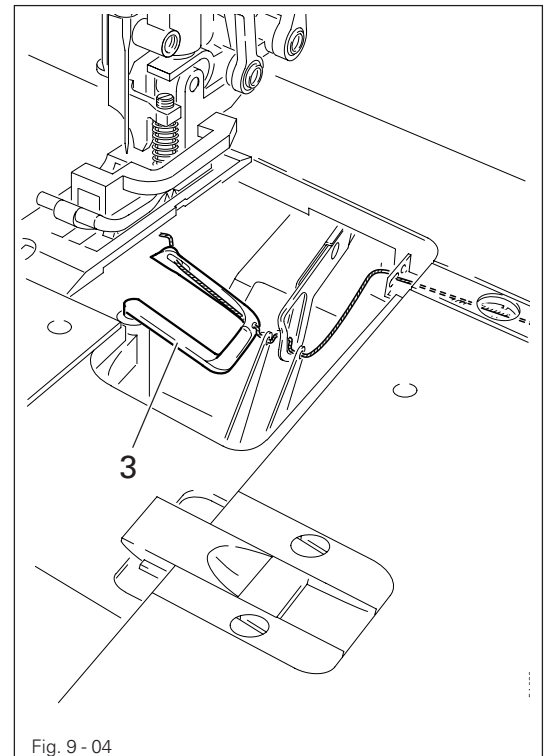
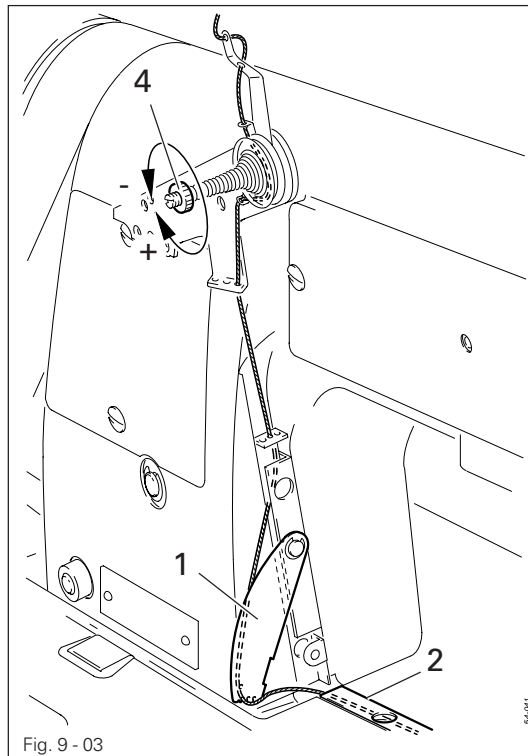

Switch off the machine!

Danger of injury by unintentional starting of the machine!

- Open the looper cover and swing out thread guide plate 1.
- Thread the looper thread as shown in Figs. 9-03 and 9-04 and pull it under guide plate 2.
- Thread looper 3 using tweezers.
- Regulate the looper thread by turning knurled screw 4.

9.04 Selecting the program number

- Switch on the machine.



- Call up the program number input menu.

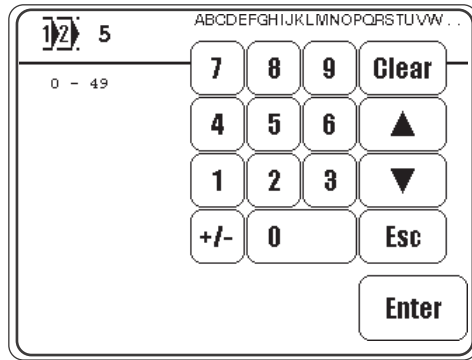

- Select the desired program number.

Enter

- Confirm the selection and quit the selection menu.



The type of sewing is stipulated with the selection of the program number, see **Chapter 10 Sewing**.

Program number 0:	Manual sewing
Program number 1 and 2:	Sewing with fixed programs
Program number 3 to 49:	Programmed sewing

9.05 Inputting fullness

- Switch on the machine.



- Call up the program number input menu.

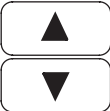

- Select program number "0".



- Confirm the selection and quit the selection menu.

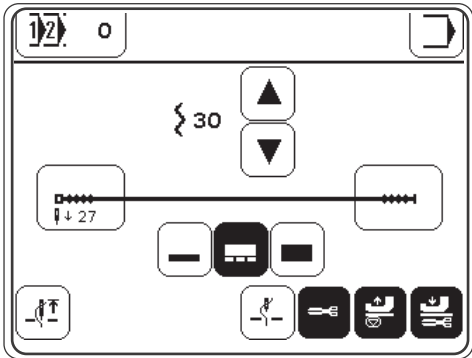

- Enter the desired value with the appropriate arrow keys.

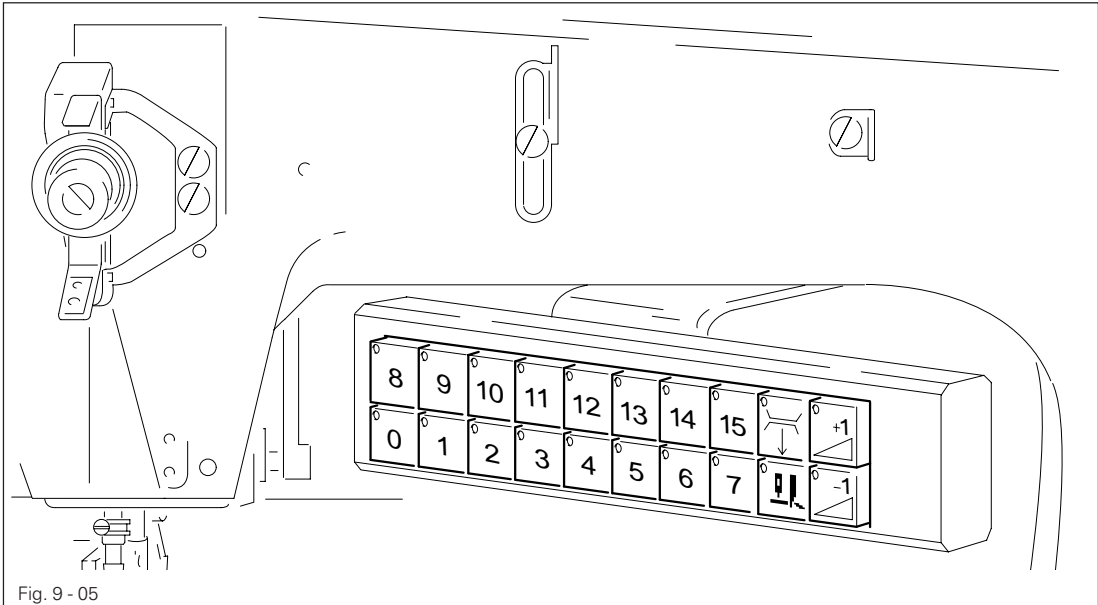

- If necessary, allocate the current fullness amount to one of the number keys (0-15) on the keyboard. To do so, press the required key until a beep is heard.

9.06 Entering / altering the code number

- Switch on the machine.



- Call up the input mode.

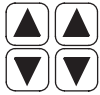
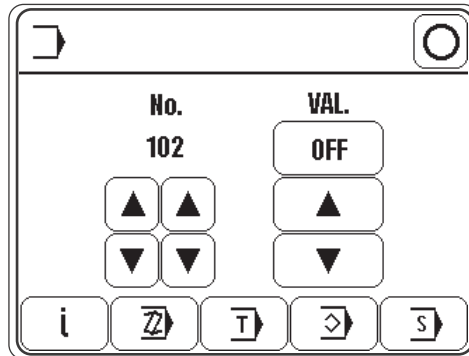

- Select parameter "800".

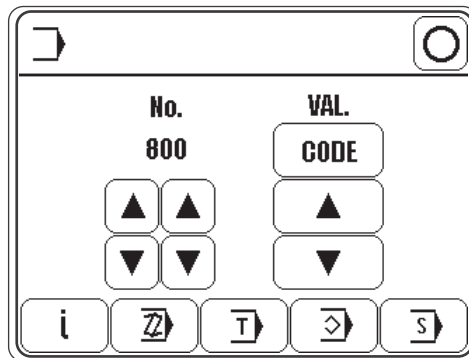

CODE

- Select the code number input menu.
- Enter the code number on the number keys (factory code setting is "3800").

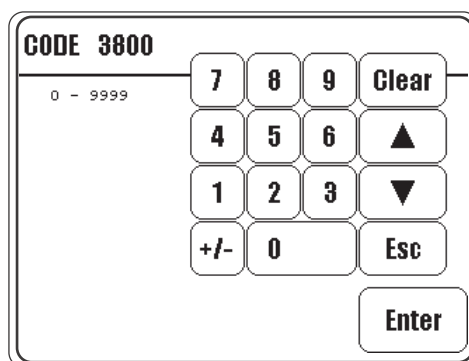

Enter

- Take over the code number entered.

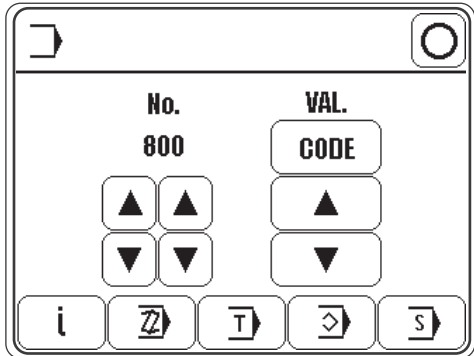

The code input remains stored until the machine is switched off at the main switch. As long as the machine is not switched off, all parameters are freely accessible without having to enter the code number again.



- Select parameter "810"

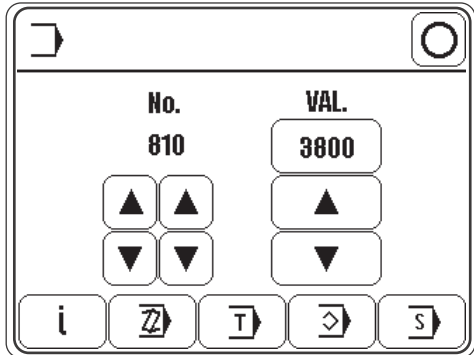

3800

- Call up the code number input menu and enter the desired code number.

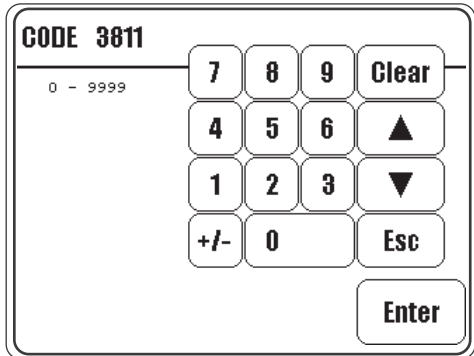

Enter

- Take over the new code number.



- Conclude input.



Do not forget the code!
Without the appropriate code, the protected functions cannot be called up!
Help is then only possible through PFAFF service staff.

9.07 Adjusting the control panel

- Switch on the machine.



- Call up the input mode.

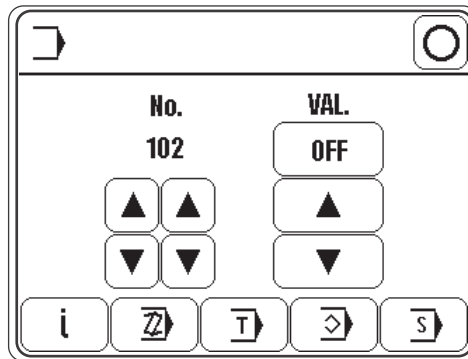

- Select the service menu.

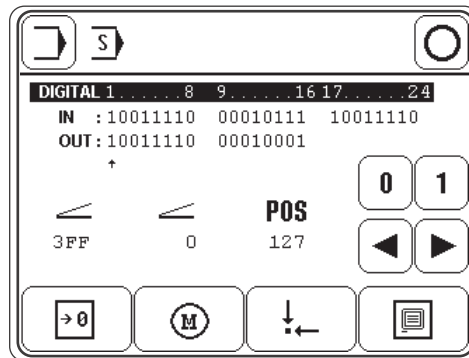

- Select control panel functions.

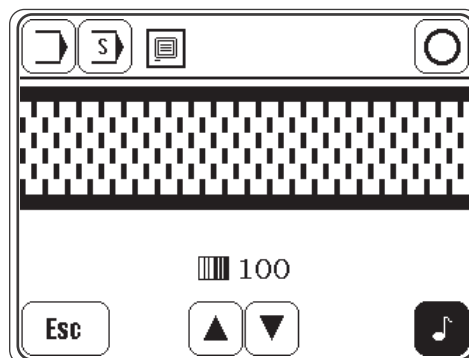

- Change the display contrast.



- Switch the key tone off or on.



Never reduce the display contrast to the extent, that the display can no longer be read!

10 Sewing

In the sewing mode all relevant settings for the sewing operation are displayed on the screen and can be altered with the corresponding functions.

In the sewing mode a difference is made between manual sewing, sewing with fixed programs and programmed sewing.

The selection is made with the corresponding program number:

- 0: Manual sewing
- 1 and 2: Sewing with fixed programs
- 3 to 49: Programmed sewing
(with up to 15 seam sections for both the left and right seam)

10.01 Manual sewing

In the manual sewing mode the values for fullness and the stitch placement position are shown on the display when sewing starts, and like the functions at the end of the seam, the material type and the needle and sewing foot positions, can be changed directly with the appropriate function.



- Switch on the machine and select program number "0", see [Chapter 9.04 Selecting the program number](#).

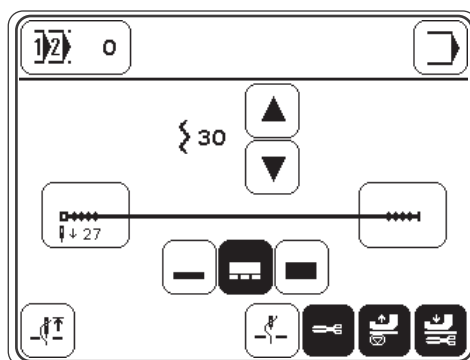

Explanation of the functions



Program selection

This opens the menu for entering the program number, see [Chapter 9.04 Selecting the program number](#).



Input mode

Exit the sewing mode and select the input mode.



Fullness

Alters the value for fullness, see [Chapter 9.05 Inputting fullness](#)



Seam start (placement stitch/condensed stitch)

Opens the menu for entering the value for the placement stitch and condensed stitch at the beginning of the seam, see [Chapter 10.01.01 Entering the seam start and seam end in the manual sewing mode](#).



Seam end (condensed stitches)

Opens the menu for entering the values of the condensed stitches at the end of the seam, see **Chapter 10.01.01 Entering the seam start and seam end in the manual sewing mode.**



Material type

These functions are used for selecting the type of material, see **Chapter 10.01.02 Selecting the material type.**



Needle raised

Moves the needle to its highest position



Needle position raised

When this function is activated, the needle moves to its highest position after sewing stops.



Thread trimming

- when the function is activated, enables thread trimming with the pedal function (optional).
- when the function is activated, the edge knife can be switched off with the pedal function, see **Chapter 7.02 Pedal.**



Sewing foot raised

When this function is activated, the sewing foot is raised after sewing stops.



Sewing foot lowered after the edge knife has been switched off

When the function is activated, the sewing foot is not raised after the edge knife has been switched off.

- Sewing is carried out with the pedal functions, see **Chapter 7.02 Pedal.**

10.01.01 Entering the seam start and seam end in manual sewing mode



After calling up the appropriate function, the menu for entering the placement stitch function appears. To begin with the condensed stitches function is not activated.

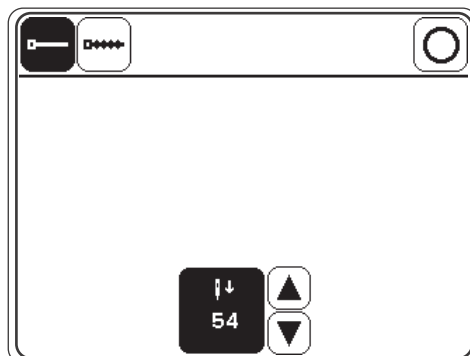

- If necessary, change the placement stitch value (using the number keys or arrow keys).



- If necessary, call up the menu for entering the condensed stitches.

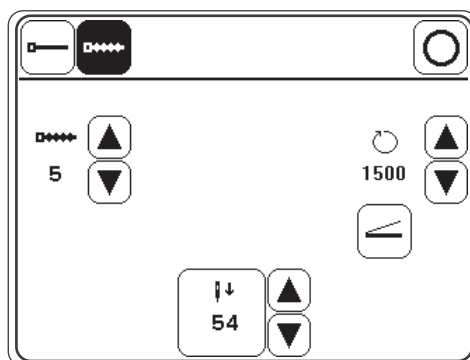

- If necessary, switch off the condensed stitches function.



- Enter the number of condensed stitches.



- If necessary, enter the maximum speed for the condensed stitches.



- Select whether the condensed stitches are to be sewn at a fixed speed (standard symbol) or at a pedal-controlled speed (inverse symbol)





- Conclude the input.



In the manual sewing mode, the functions for the seam end are entered in the same way as those for the seam start (without placement stitch).











10.01.02 Selecting the material type

To achieve equal results (fullness amounts) when sewing different materials, in the manual sewing mode and when working with fixed programs, it is possible to choose between 3 different types of material at any time:

-  **Light materials** (without padding here)
-  **Medium materials** (without padding here)
-  **Heavy materials** (without padding here)

The symbol of the present material type selected is shown as an inverse symbol.

For each type of material it is possible to select 4 different levels of padding. For this purpose the symbol of the corresponding type of material must be pressed as often as necessary until the relevant padding level appears on the display:

  	no padding
  	approx. 80 g/m ² padding
  	approx. 200 g/m ² padding
  	approx. 400 g/m ² padding

10.02 Sewing with fixed programs

Fixed programs are stored under the program numbers **1** and **2**.

The fixed programs are used for the quick and easy production of seams with different amounts of fullness. When sewing with fixed programs, 2 or 3 seam sections are sewn after each other. With the knee switch it is possible to move to the next section. The fixed programs are designed as cyclic running programs, i.e. at the end of the last seam section, the machine moves back to the first seam section. The fullness value can be set for each seam section, the settings for the stitch placement position and for the needle and sewing foot positions apply to all sections and can be changed at any time with the corresponding function..



- Switch on the machine and select program number "1" or "2", see [Chapter 9.04 Selecting the program number](#).

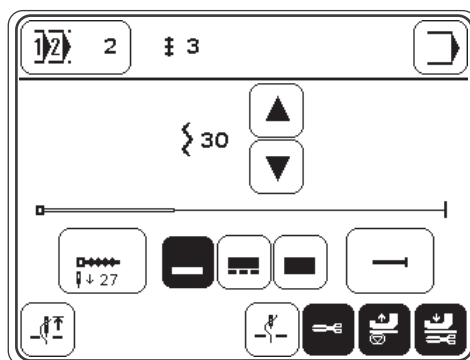

Explanation of the displays and functions



Program selection

This opens the menu for entering the program number, see [Chapter 9.04 Selecting the program number](#).

I 2 Seam section

Shows the number of seam sections in the sewing program.



Input mode

Exit the sewing mode and select the input mode.



Fullness

Alters the fullness value, see [Chapter 9.05 Inputting fullness](#).



Seam start (placement stitch/condensed stitches)

Opens the menu for entering the value for the placement stitch and the condensed stitches at the beginning of the seam, see [Chapter 10.01.01 Entering the seam start and seam end](#) in manual sewing.



Seam end (condensed stitches)

Opens the menu for entering the value for the condensed stitches at the end of the seam, see [Chapter 10.01.01 Entering the seam start and seam end](#) in manual sewing.



Material type

These functions are used to select the material type, see **10.01.02 Selecting the material type**.



Needle raised

Moves the needle to its highest position



Needle position raised

When this function is activated, the needle moves to its highest position after sewing stops.



Thread trimming

- when the function is activated, enables thread trimming with the pedal function (optional).
- when the function is activated, the edge knife can be switched off with the pedal function, see **Chapter 7.02 Pedal**.



Sewing foot raised

When this function is activated, the sewing foot is raised after sewing stops.



Sewing foot lowered after the edge knife has been switched off

When the function is activated, the sewing foot is not raised after the edge knife has been switched off.

- Sewing is carried out with the pedal and knee switch functions, see **Chapter 7.02 Pedal** or **7.04 Knee switch**.

10.03 Programmed sewing

With the program numbers **3 – 49** it is possible to call up **previously** programmed seams. In programmed sewing all seam sections for pre-gathering a sleeve are set in one seam program. The information about the seam program, such as program number, number of programmed seam sections, programmed comments is displayed.

For better orientation a seam sketch is shown with the programmed seam sections. The seam start, seam end, the seam sections already sewn, the current seam section and the seam sections still to be sewn are illustrated by symbols and different types of lines with different thicknesses. For the current seam section the corresponding parameters for seam section number, fullness with fullness adjustment and the number of stitches (length of seam section) are displayed. The material typ and other functions can be altered directly.



- Switch on the machine, select the desired program number from "3" to "49", see **Chapter 9.04 Selecting the program number**.

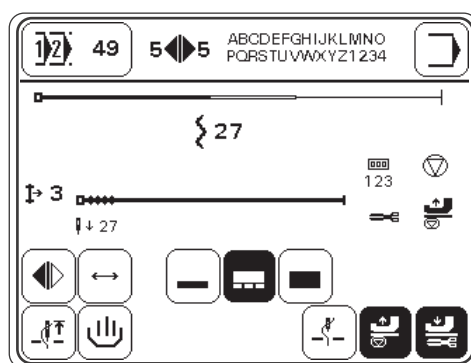

Explanation of the displays and functions



Program selection

This opens the menu for entering the program number, see **Chapter 9.04 Selecting the program number**.



Seam section right/left

Shows the number of seam sections in the seam program for the right/left sleeve seam.



Input mode

Exit the sewing mode and select the input mode.



Fullness

Shows the current fullness value.



Current seam section

Shows the current seam section.



Placement stitch

Shows the current placement stitch value.



Current seam

This function is used to select and display the current sleeve seam (right/left).



Automatic seam change

When this function is activated, the machine changes automatically from the right to left sleeve seam.



Material type

These functions are used to select the material type, see **10.01.02 Selecting the material type**.



Needle raised

Moves the needle to its highest position



Program interruption

Interrupts the program sequence, see **Chapter 10.03.01 Program interruption**



Thread trimming

- when the function is activated, enables thread trimming with the pedal function (optional).
- when the function is activated, the edge knife can be switched off with the pedal function, see **Chapter 7.02 Pedal**.



Sewing foot raised

When this function is activated, the sewing foot is raised after sewing stops.



Sewing foot lowered after thread trimming

When this function is activated, the sewing foot is not raised after thread trimming.

- Sewing is carried out with the pedal functions, see **Chapter 7.02 Pedal**.

10.03.01 Program interruption

With the "program interruption" function the programmed seam sequence is interrupted (e.g. if the thread breaks).



- Interrupt program sequence.

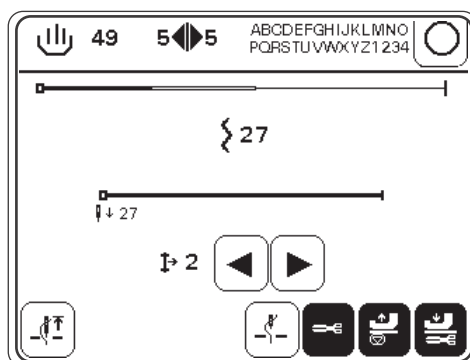

- If necessary, tact forwards or backwards through the sections of the seam program.

- If necessary, change the values and carry out the other functions as in manual sewing, see **Chapter 10.01 Manual sewing**.



- If necessary, call up programmed sewing again..

10.04 Error messages

If an error occurs, the text "ERROR" appears on the display, together with an error code. An error message is caused by incorrect settings, defective elements or seam programs and by overload conditions.

For an explanation of the error codes see **Chapter 13.09 Explanation of the error messages**.

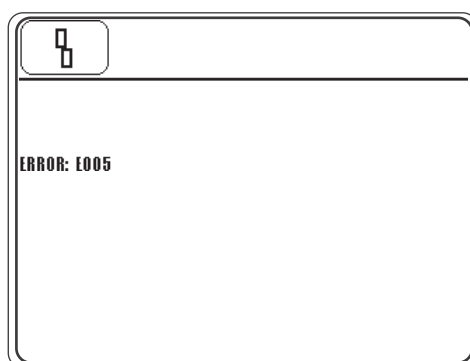

- Eliminate the error.



- Confirm error elimination.

11 Input

In the input mode the functions parameter input, information, creating/adjusting a sewing program, teach-in, program administration and service are available.

- Switch on the machine.



- Call up the input mode.

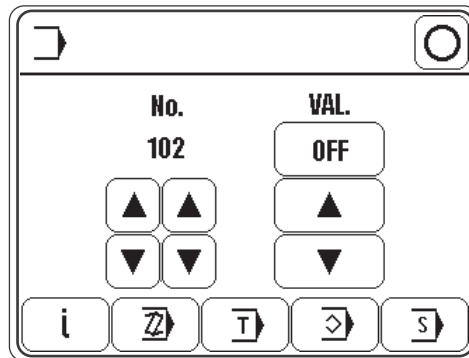

Explanation of the functions



Sewing mode

Quit the input mode and call up the sewing mode.



Parameter selection

Select the hundred and unit figures of the desired parameters, see Chapter 13.07.02

Example of a parameter input.

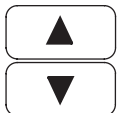

Altering the parameter value

Change the value of the selected parameter, see Chapter 13.07.02 Example of a parameter input.



Software information

Calls up information about the current machine software.



Creating/adjusting a program

Opens the menu for entering or altering a seam program, see Chapter 11.01.02 Seam program input with the "Creating/adjusting a program" function.



Teach In

Opens the menu for entering seam programs after sewing a sample, see Chapter 11.01.04 Seam program input with the "Teach in" function.



Program administration

Opens the menu for seam program administration, see Chapter 11.03 Seam program administration.



Service

Opens the service menu, see Chapter 13.12 Service menu.

11.01 Seam program input

Seam programs can be created by entering parameters in the "Creating/adjusting a seam program" function, or by sewing a sample with the "Teach in" function. Irrespective of which function is being used, first of all it is necessary to select the program number and the basic settings of the seam program, which is to be sewn.

11.01.01 Basic settings for seam program input

The basic settings in the "creating/adjusting a program" and the "teach-in" functions are the same.

- Switch on the machine.



- Call up the input mode.



- Call up the "Creating/adjusting a seam program" or the "Teach in" function.

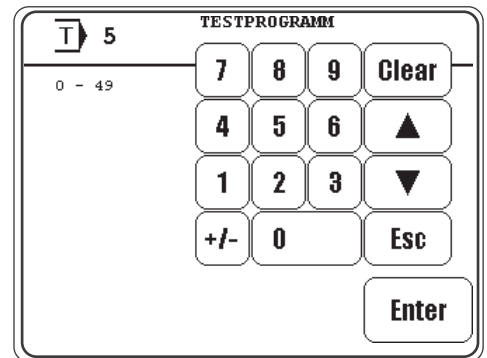
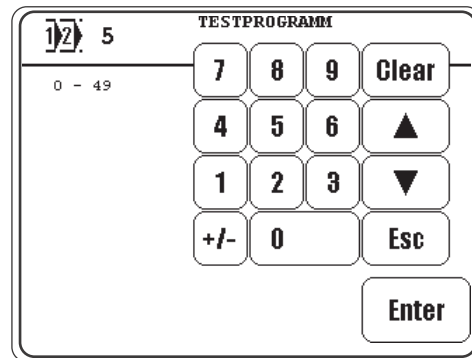

- If necessary, change the selected program number and confirm the selection.

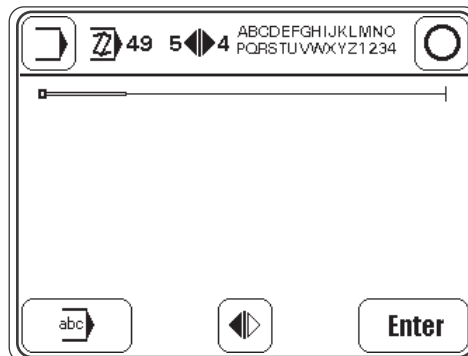

- If applicable, enter or change a comment.



- Set the seam type (by pressing the appropriate symbol several times until the appropriate seam type is displayed).

Description of the symbols:



Sewing program with left and right seam, beginning with the right seam.



Sewing program with left seam only.



Sewing program with right seam only.



Sewing program with left and right seam, beginning with the left seam.

Enter

- Conclude the input of the basic settings and change to the seam section input, see **Chapter 11.01.02 Seam program input with the "Creating/adjusting a program" function** or **Chapter 11.01.04 Seam program input with the "Teach in" function**.



The input can also be concluded by calling up the sewing mode. In this case the seam program input is concluded and the machine changes to programmed sewing.

11.01.02 Seam program input with the "Creating/adjusting a program" function

With this function the seam program is entered by entering or changing the appropriate values on the control panel. This type of seam program input is particularly suitable for adjusting existing seam programs.

- Switch on the machine.



- Call up the input mode.



- Call up the "creating/adjusting a program" function.



- Carry out the basic settings and conclude with the "Enter" function, see **Chapter 11.01.01 Basic settings for seam program input.**

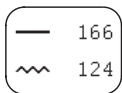
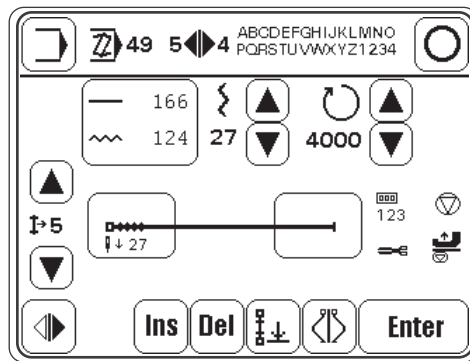

- Alter the actual and required length of the seam, see **Chapter 11.01.03 Entering the actual and the required length of the seam section.**



- Alter the fullness, see **Chapter 9.05 Inputting fullness.**



- Alter the maximum speed for the current seam section.

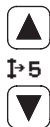

- These functions are used to scroll through the current seam program. The current seam section is displayed accordingly, in addition to all the other current values.



- Enter the seam start functions, see **Chapter 10.01.01 Entering the seam start and seam end in manual sewing mode.**



- Enter the functions for the end of the seam section, see **Chapter 11.01.05 Entering the end of the seam section when programming the seam.**





- Select a seam type. It is only possible to select the right or left seam, if the seam type "right and left seam" was selected in the basic setting, see **Chapter 11.01.01 Basic settings for seam program input.**

Ins ● If necessary, insert the seam section.
The current seam section is copied and all following seam sections are set one place back.

Del ● If necessary, delete the current seam section.

 ● If necessary, conclude the input of the current seam and store the parameter for the other seam in the reverse order (mirror seam).

  ● Set the seam end or program end.
If entering only one seam (only the right or only the left sleeve seam) the program end is set in the desired seam section.
In the same way as the program end, the seam end is set when entering the right and left sleeve seam. The seam end is set in the first sleeve seam and the program end in the second sleeve seam.

Enter ● Conclude the input of the first seam section and change to the next seam section.



 ● Conclude the input and change to the input of the basic settings.

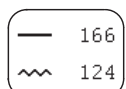

 ● Conclude the input and change to programmed sewing.

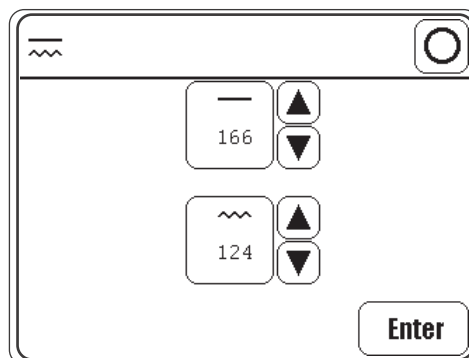
11.01.03 Entering the actual and required length of the seam section

 After the corresponding function has been called up, the menu for entering the seam length (in mm) of the current seam section appears. After the input of the values for the actual and required length, the number of stitches and the fullness amount are calculated. A subsequent alteration of the number of stitches also alters the values for the actual and required length.



   ● Alter the value for the actual length (using the number panel or arrow keys).

   ● Alter the value for the required length (using the number panel or arrow keys).

Enter ● Conclude the input.

11.01.04 Seam program input with the "Creating/adjusting a program" function

With this function the seam program is entered by sewing a sample. A new program is always created, i.e. if an existing program is selected, this will be overwritten.

- Switch on the machine.



- Call up the input mode.



- Call up the "teach-in" function.



- Carry out the basic settings and conclude with the "Enter" function, see **Chapter 11.01.01 Basic settings for seam program input.**

Before sewing starts the following displays and functions appear on the screen.

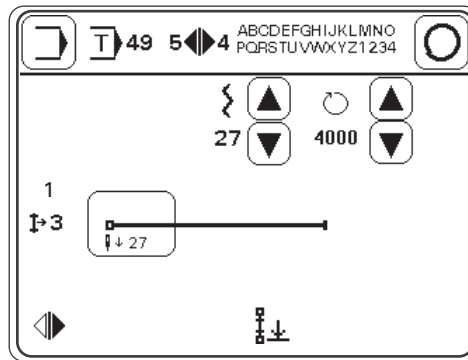

- Enter the functions for the seam start, see **Chapter 10.01.01 Entering the seam start and seam end in the manual sewing mode.**



- Enter the fullness, see **Chapter 9.05 Inputting fullness.**



- Enter the maximum speed for the current seam section.

- Sew the first seam section using the pedal function.
The number of stitches in the current seam section is counted and shown on the display.

After sewing starts, the following displays and functions are shown on the screen.

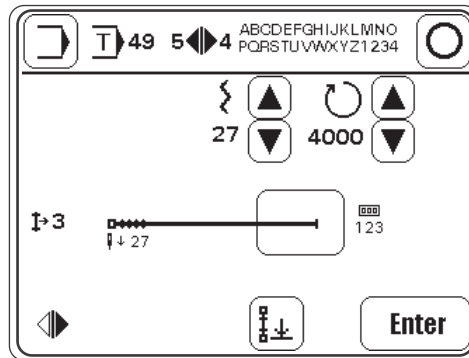

Enter

- By pressing Enter the seam section end is defined by stitch counting.
- By operating the pedal in position "-2", the seam section is ended by pedal operation, see Chapter 7.02 Pedal.
- By operating the knee switch, the seam section is ended by knee switch operation, see Chapter 7.04 Knee switch.



- After the function has been called up, additional inputs can be made for the seam section end or incorrect inputs can be corrected, see **Chapter 11.01.05 End of seam section input during seam programming.**





Condensed stitches defined during the input of the functions for the end of the seam section, will be carried out after the seam program input has been concluded. Up to 30 stitches will be sewn! Danger of injury in the needle area!



- Set the seam end or program end.
If entering only one seam (only the right or only the left seam) the program end is set in the desired seam section.
In the same way as the program end, the seam end is set when entering the right and left seam. The seam end is set in the first seam and the program end in the second seam.

Enter

- Conclude the input.
-  ● Conclude the input and change to the input of the basic settings.
-  ● Conclude the input and change to programmed sewing.

11.01.05 End of seam section input during seam programming



After the appropriate function has been called up, the menu for entering the functions and values for the end of the seam section without condensed stitches appears.

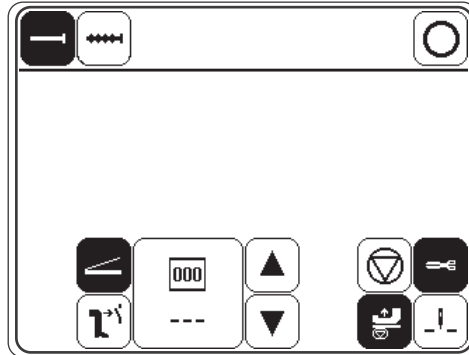

● If necessary, call up the menu for entering the condensed stitches.

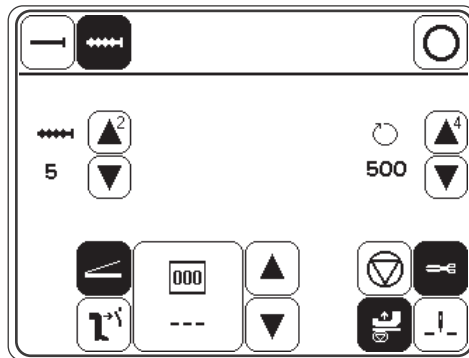

● If necessary, switch off the condensed stitches function.



● Enter the number of condensed stitches.



● If necessary, enter the maximum speed for the condensed stitches.



● Switch the pedal function for changing to the next seam section on or off.



● Switch the knee switch function for changing to the next seam section on or off.



● Enter or change (with the number keys or arrow keys) the number of stitches for the seam section.





● Execute or do not execute the automatic sewing stop function at the end of the seam section.



● Switch the "sewing foot raised" function on or off, see **Chapter 10.01 Manual Sewing**.

Input

-  ● Switch the "thread trimming" function on or off, see **Chapter 10.01 Manual Sewing**.
-  ● Switch the "needle raised" function on or off, see **Chapter 10.01 Manual Sewing**.
-  ● Conclude the input and change to programmed sewing.



It is not possible to set every combination of functions.
All the activated functions are shown as inverse symbols.

11.02 Examples of how to create a seam program

11.02.01 Example of a seam program input with the "creating/adjusting a program" function

The seam program to be created should

- have 4 seam sections and
- be stored under the program number "4" with the comment "PROG".

- Switch on the machine.



- Call up the input mode.



- Call up the "creating/adjusting a seam program" function and enter program number "4".

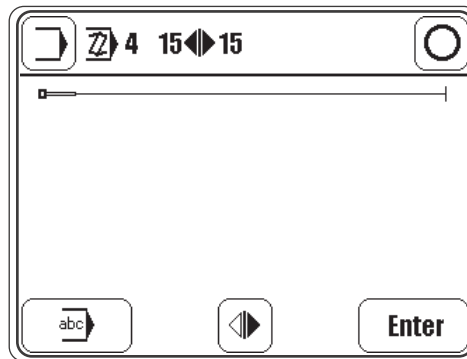

- Set the seam type (right seam) by pressing until the appropriate symbol appears.



- Call up the menu for comment input.

- Enter the comment "PROG" with the keyboard and number panel.



- Conclude the comment input.



- Change to the input of the first seam section.

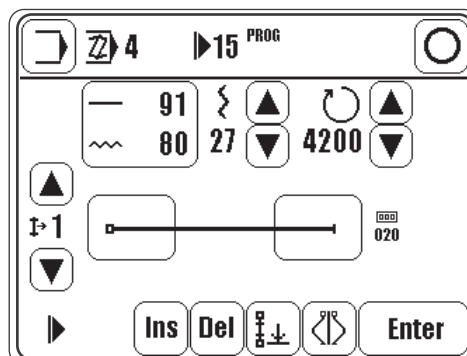

Input

In the first seam section

- sewing should be carried out without fullness,
- the end of the seam section should be carried out with the knee switch.



- Enter the value "0" for the fullness.



- Call up the menu for the input of the end of the seam section.



- Switch to the next seam section with the knee switch.

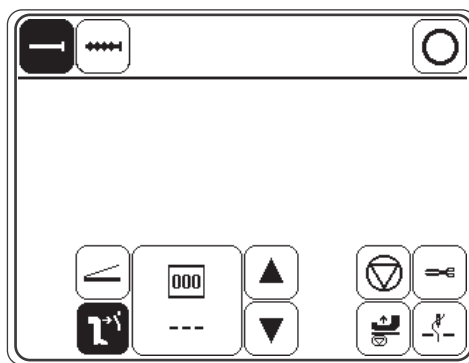

- Conclude the input of the end of the seam section.

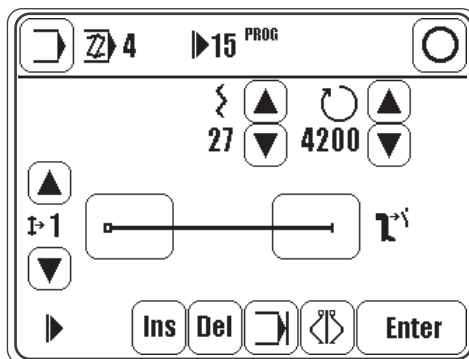

Enter

- Change to the input of the second seam section.

In the second seam section

sewing should be carried out with an actual length of 242 mm and a required length of 140 mm.

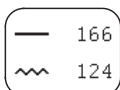

- Call up the menu for entering the required/actual length of the seam section.

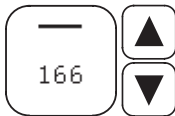
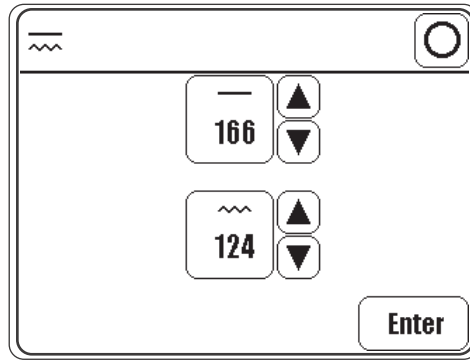

- Enter the value "242" for the actual length.



- Enter the value "140" for the required length.

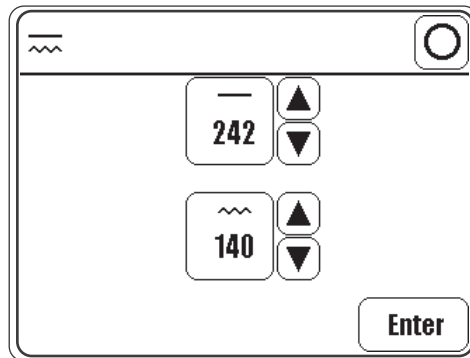

- Conclude the input of the required/actual length.

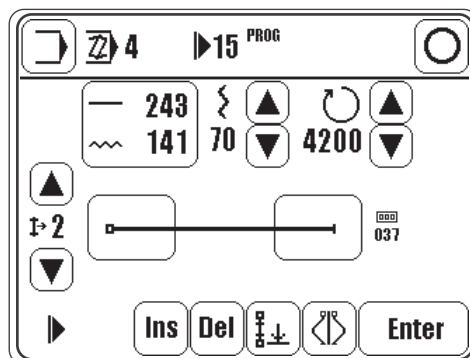

The number of stitches ("37") and the value for the fullness ("70") are calculated from the values entered. As this calculation is based on whole stitches, the value for the required length ("141") differs slightly from the value entered.



- Change to the input of the third seam section.

In the third seam section sewing should be carried out with an actual length of 190 mm and a required length of 160 mm.

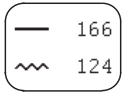

- Call up the menu for entering the required/actual length of the seam section and enter the values for the required and the actual length.



- Conclude the input of the required/actual length.

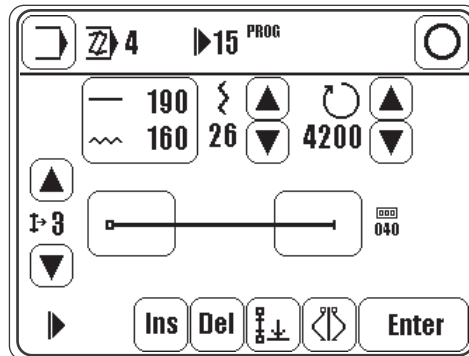

- Change to the input of the fourth section.

In the fourth seam section

- sewing should be carried out without fullness,
- the end of the seam section should be carried out with the pedal function
- the "thread trimming" and "sewing foot raised" functions should be activated.



- Enter the value "0" for the fullness.



- Call up the menu for the input of the end of the seam section.



- Switch to the next seam section with the pedal function.



- Switch on the "thread trimming" function.





- Switch on the "sewing foot raised" function.

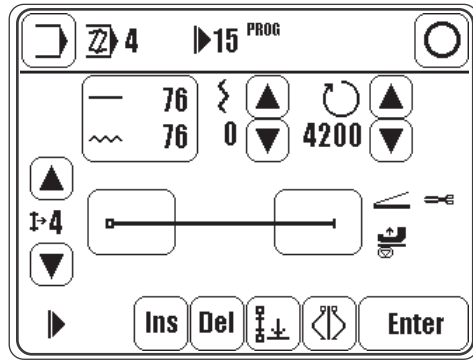

- Conclude the input.



-  ● Activate the "end of program" function.
-  ● Conclude the seam program input and change to programmed sewing

11.02.02 Example of a seam program input using the "teach-in" function

The seam program to be created should

- consist of a left seam,
- have 5 seam sections,
- be stored under the program number "11" with the comment "TEACH".

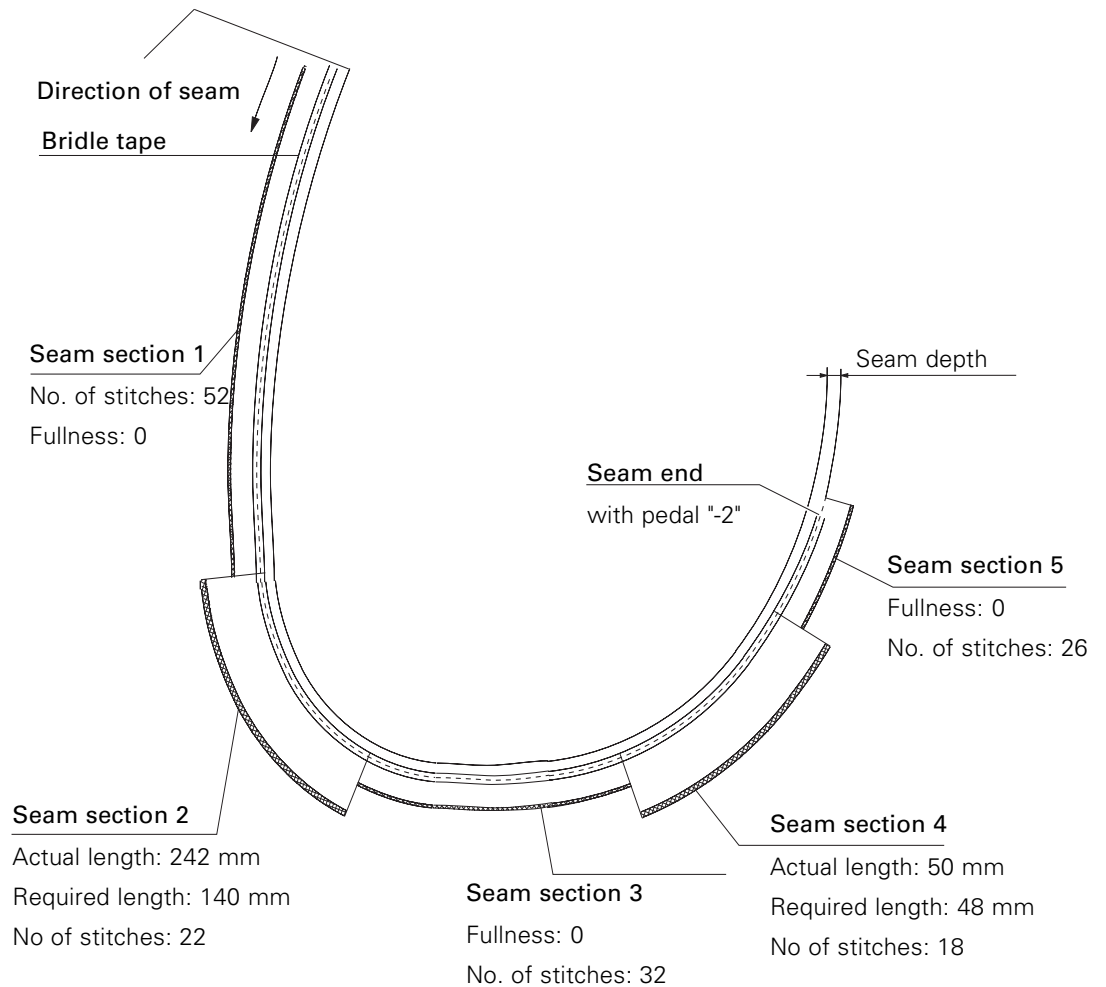

Input

- Switch on the machine.



- Call up the input mode.



- Call up the "teach-in" function and enter program number "11".

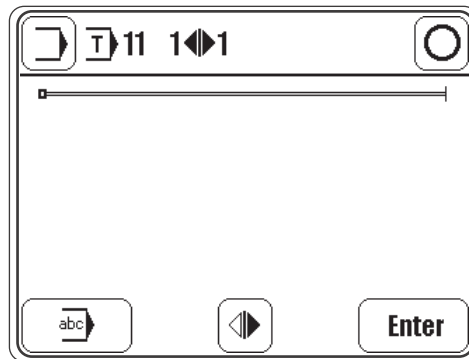

- Set the seam type (only left seam) by pressing until the appropriate symbol appears.



- Call up the menu for comment input.

- Enter the comment "TEACH" with the keyboard and number panel.



- Conclude the comment input.



- Change to the input of the first seam section.

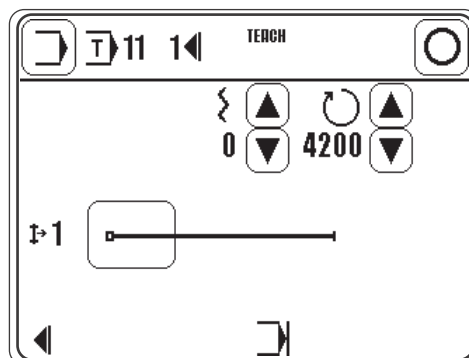

The first seam section should be sewn without fullness (value "0").



- If necessary, enter the value "0" for fullness.
- Sew the first seam section using the pedal function.

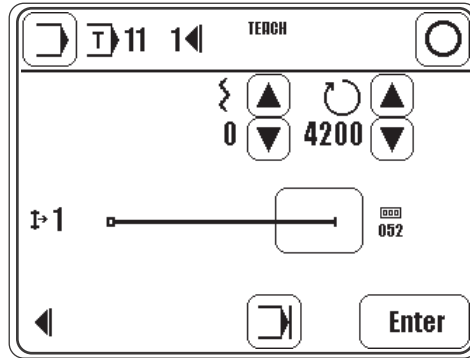

- Change to the input of the second seam section.

The second seam section should be sewn with a fullness value "30".



- Enter the value "30" for the fullness.
- Sew the second seam section using the pedal function.

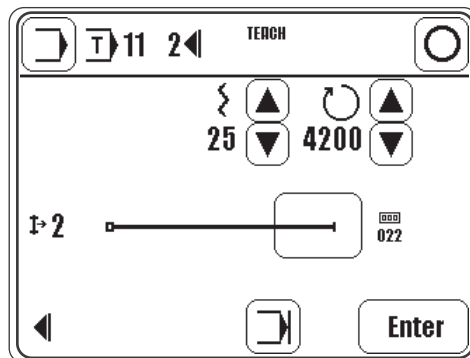

- Change to the input of the third seam section.



- Enter the value "0" for fullness.
- Sew the third seam section using the pedal function.



- Change to the input of the fourth seam section.



- Enter the value "27" for the fullness.
- Sew the fourth seam section using the pedal function.

Enter

- Change to the input of the fifth seam section.



- Enter the value "0" for fullness.
- Sew the fifth seam section using the pedal function.
- Set the end of the seam section with pedal position "-2", see [Chapter 7.02 Pedal](#).

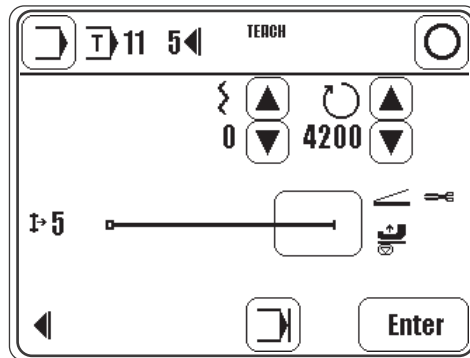

- Activate the "end of program" function.



When the seam program input is concluded, the thread trimming operation is carried out automatically!



- Conclude the seam program input and change to programmed sewing.

11.03 Seam program administration

In the program administration the seam programs deposited in the machine memory are displayed and can be deleted or copied.

- Switch on the machine.



- Call up the input mode.



- Call up program administration.

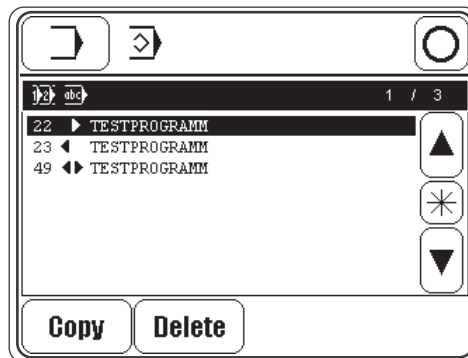

Explanation of the functions



Input mode

Calls up the basic display for the input mode.



Sewing mode

Quit input mode and call up sewing mode.



Program selection



After the program administration has been selected, at least one seam program is always marked. Using the arrow functions, the desired seam program can be selected. With the *-



function and the arrow functions a seam program block can be marked. By pressing the *.function again, the block function is deactivated.



Copy

Selected seam programs are copied.



Delete

Selected seam programs are deleted.

12 Care and Maintenance

Clean looper compartment	daily, several times if in continuous use
Clean the entire machine	once a week
Check the oil level	daily, before use
Lubricate the articulated joints of the top feed	once a week
Check/adjust the air pressure	daily, before use
Clean air filter of air filter/regulator	as required



These maintenance intervals are calculated for the average running time of a single shift operation. If the machine is operated for a longer period, shorter intervals are recommended.

12.01 Cleaning

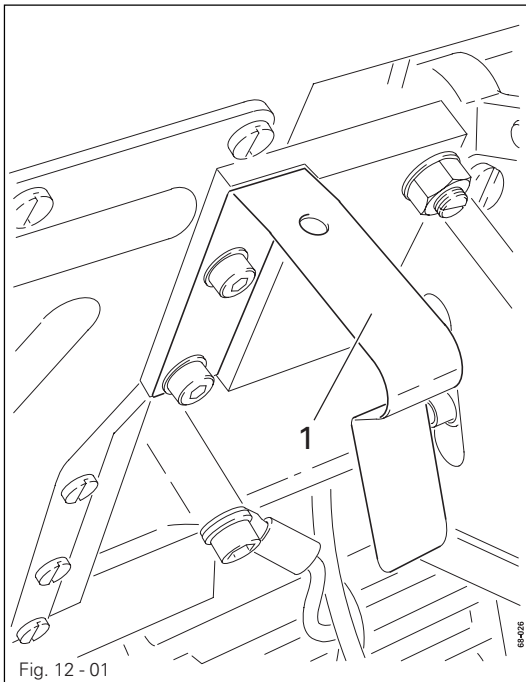

Switch the machine off!
Danger of injury if the machine is started accidentally!

- Tilt sewing head back.
- Clean looper and looper compartment daily, several times if in continuous operation.
- When returning the machine to an upright position, make sure that tilt lock 1 is pressed.



Use both hands to set the sewing head upright!
Danger of crushing between the sewing head and the table top!

12.02 Machine oil level

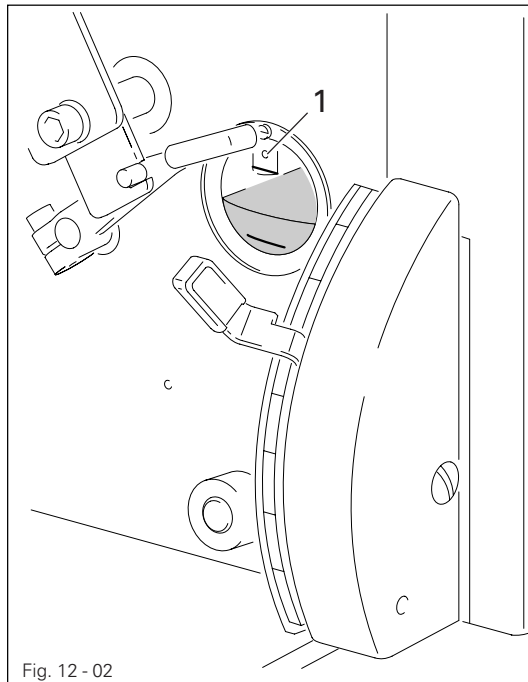

Fig. 12 - 02



Check oil level before each use.

- The oil level must be between the markings in the inspection glass.
- If required refill oil through hole 1.



Only use oil with a mean viscosity of 22.0 mm²/s at 40° C and a density of 0.865 g/cm³ at 15° C!.



We recommend PFAFF sewing machine oil. Order-No. 280-1-120 144.

12.03 Cleaning/lubricating the top feed joints

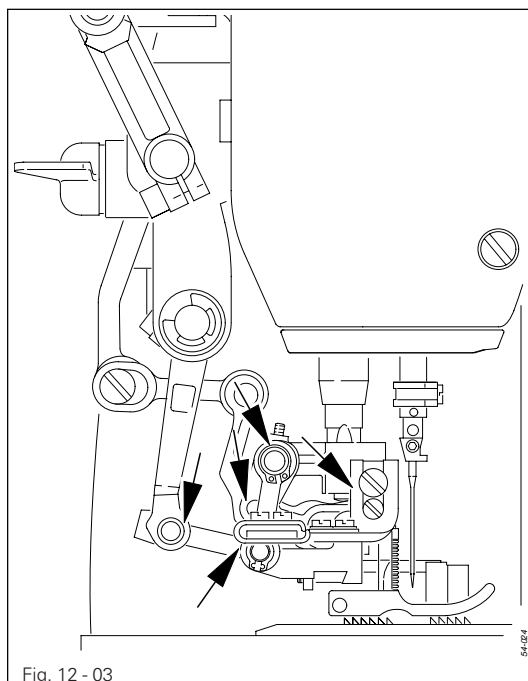
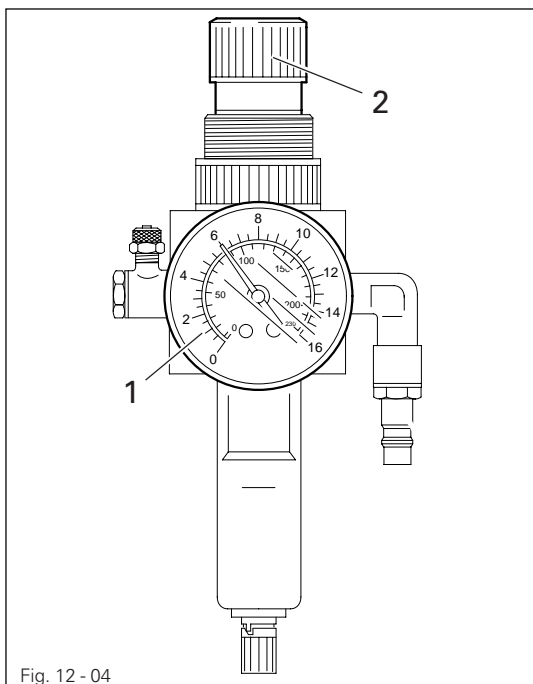

Fig. 12 - 03

- Once a week or after the machine has stood still for longer periods, clean the points marked in the illustration with the special cleaner, part no. 99-137 468-91.
- Afterwards lubricate these points with the special lubricant, part no. 99-137 467-91 (wipe off surplus lubricant with a cloth).

12.04 Checking/adjusting the air pressure



- Before operating the machine, always check the air pressure on gauge 1.
- Gauge 1 must show a pressure of 6 bar.
- If necessary adjust to this reading.
- To do so, pull knob 2 upwards and turn it so that the gauge shows a pressure of 6 bar.

12.05 Cleaning the air filter of the air-filter/lubricator

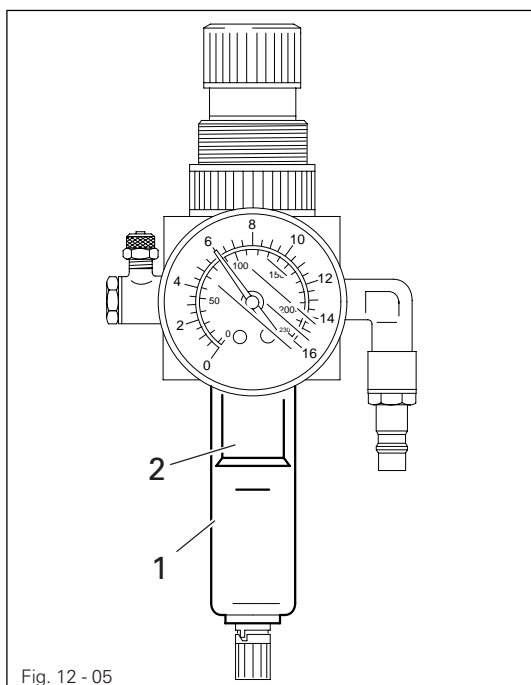

Switch the machine off!
Disconnect the air hose at the
air-filter/lubricator.

To drain water bowl 1:

- Water bowl 1 drains itself automatically when the compressed-air hose is disconnected from the air-filter/lubricator.

Cleaning filter 2:

- Unscrew water bowl 1.
- Take out filter 2.
- Clean filter 2 with compressed air or isopropyl alcohol (part No. 95-665 735-91).
- Screw in filter 2 and screw on water bowl 1.

13 Adjustment



Please observe all notes from **Chapter 1 Safety** of the instruction manual! In particular care must be taken to see that all protective devices are refitted properly after adjustment, see **Chapter 1.06 Danger warnings** of the instruction manual!



If not otherwise stated, the machine must be disconnected from the electrical power supply.

13.01 Notes on adjustment

All following adjustments are based on a fully assembled machine and may only be carried out by expert staff trained for this purpose.

Machine covers, which have to be removed and replaced to carry out checks and adjustments, are not mentioned in the text.

The order of the following chapters corresponds to the most logical work sequence for machines which have to be completely adjusted. If only specific individual work steps are carried out, both the preceding and following chapters must be observed.

Screws, nuts indicated in brackets () are fastenings for machine parts, which must be loosened before adjustment and tightened again afterwards.

13.02 Tools, gauges and other equipment

- 1 set of screwdrivers with blade widths from 2 to 10 mm
- 1 set of open-ended spanners/wrenches from 6 to 22 mm across flats
- 1 set of allen keys from 1.5 to 6 mm
- 1 screw clamp (part no. 61-111 600-35)
- 1 metal rule (part no. 08-880 218-00)
- 1 adjustment pin \varnothing 5 mm (part no. 13-030 341-05)
- 1 adjustment gauge (part no. 61-111 642-19)
- 1 adjustment gauge (part no. 91-069 375-15)
- 1 looper adjustment gauge (part no. 61-111 643-06)

13.03 Abbreviations

t.d.c. = top dead centre

b.d.c. = bottom dead centre

13.04 Control and adjustment aids



By marking the holes 1, 3, 4 and 5 with the adjustment pin (\varnothing 5 mm), the desired needle bar positions can be fixed exactly.

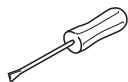
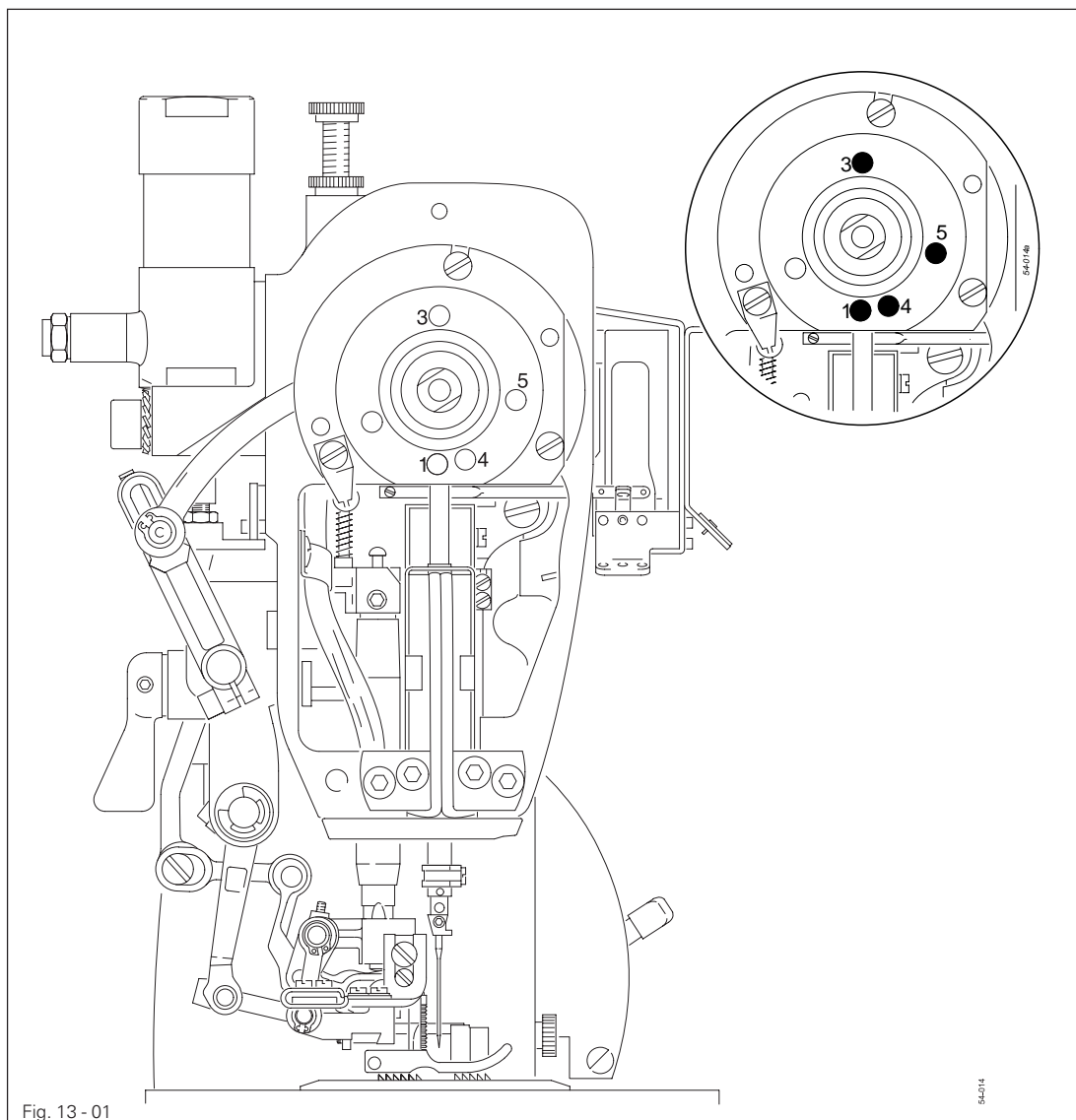

- Turn the balance wheel until the needle bar is approximately in the desired position.
- Insert the adjustment pin into the appropriate hole and apply pressure.
- Turn the balance wheel slightly backwards and forwards, until the pin locks into the rear crank recess, in this way blocking the machine.

Adjustment hole 1 = top dead centre of the needle bar (t.d.c.)

Adjustment hole 3 = bottom dead centre of the needle bar (b.d.c.)

Adjustment hole 4 = 0.8 mm before top dead centre of the needle bar (0.8 before t.d.c.)

Adjustment hole 5 = 5.5 mm before top dead centre of the needle bar (5.5 before t.d.c.)

13.05 Adjusting the basic machine

13.05.01 Basic position of the machine

- Switch on the machine.



- Call up the input mode.

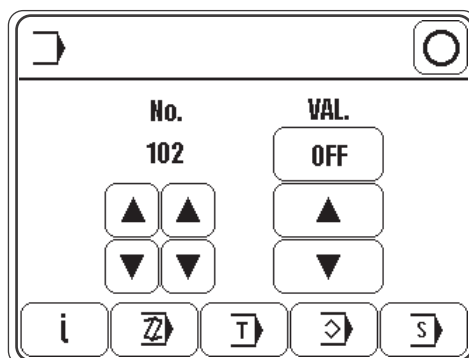

- Call up parameter "301".

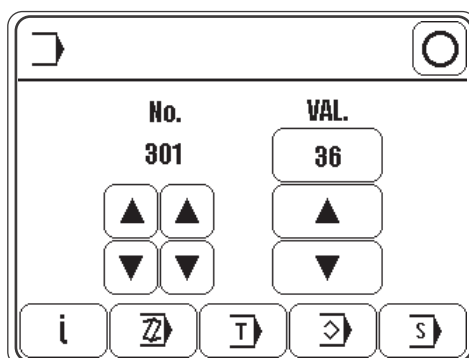

- By turning the balance wheel, position the needle point flush to the stop edge of the needle plate.



- Conclude the input.
- Switch off the machine.

13.05.02 Needle to needle hole

Requirement

1. As seen crosswise to the direction of sewing, needle **5** should be in the centre of the needle hole.
2. The distance between needle **5** and the front edge of the needle hole should be approximately **0.8 mm**.

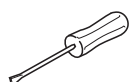
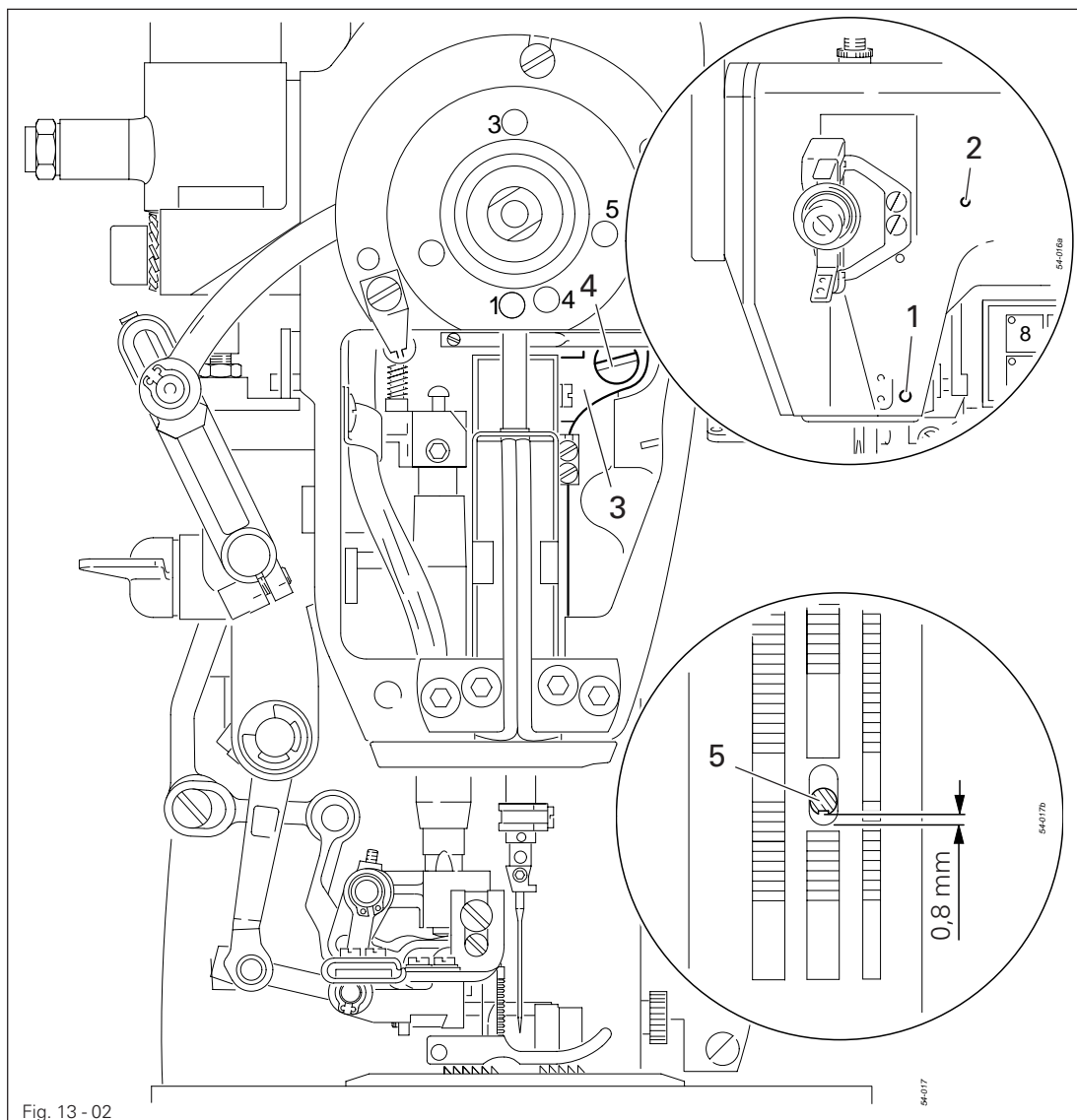

- Loosen screws **1** and **2**.
- Adjust needle bar frame **3** according to **requirement 1** and tighten screw **1**.
- Loosen screw **4** and turn needle bar frame **3** according to **requirement 2**.
- Tighten screws **2** and **4**.

13.05.03 Preliminary adjustment of the needle height

Requirement	
3811 -3/55	With the needle bar at t.d.c. (adjustment hole 1), the distance X between the needle plate and the needle tip should be 11 mm .
3811 -15/65	With the needle bar at t.d.c. (adjustment hole 1) the distance X between the needle plate and the needle tip should be 14 mm .

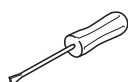
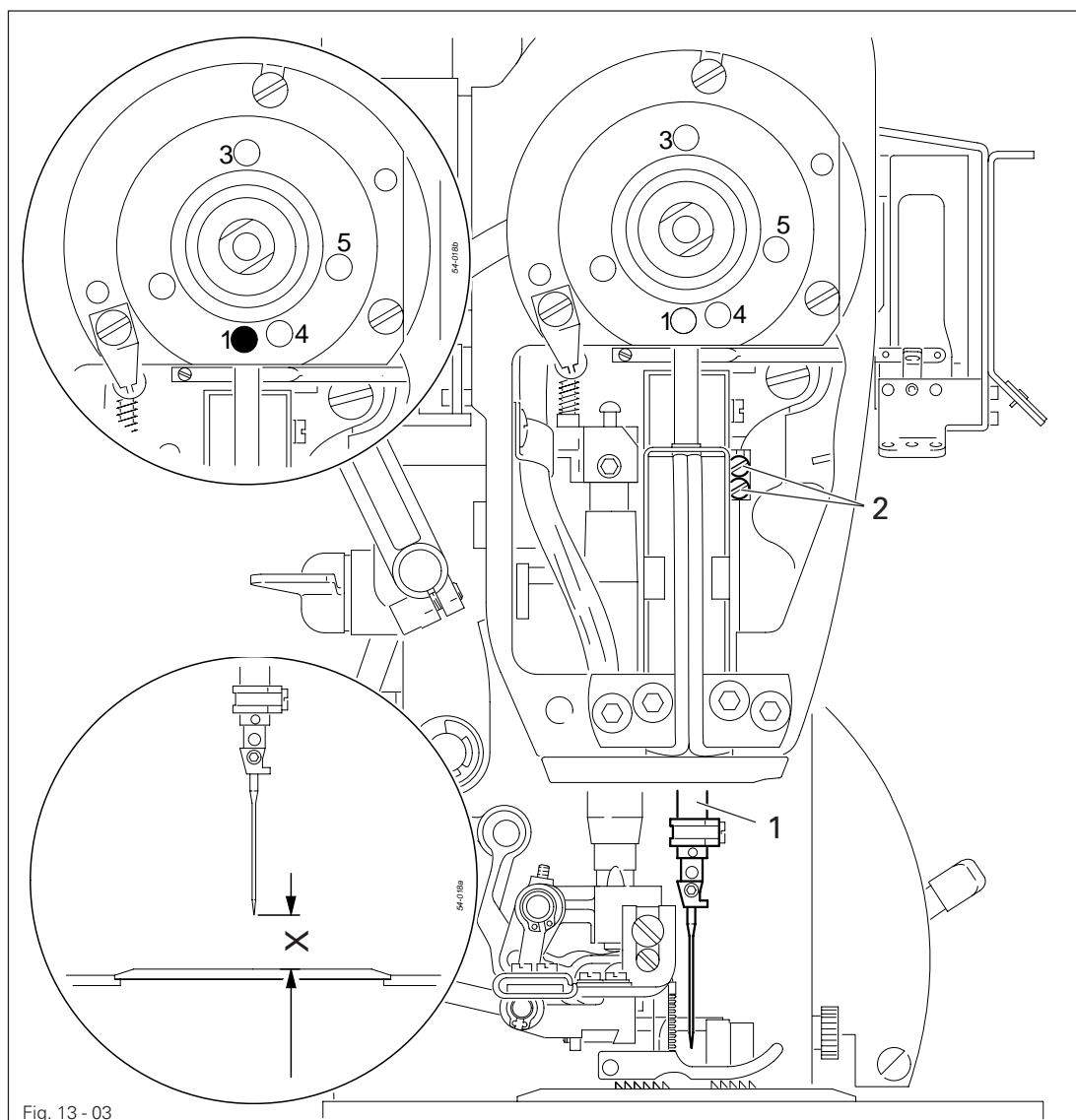

- Bring needle bar 1 to t.d.c.
- Adjust needle bar 1 (screws 2) according to the requirement.

13.05.04 Neutral position of the main feed dog

Requirement

When the stitch length is set at "0", there should be no feeding motion of the main feed dog 7.

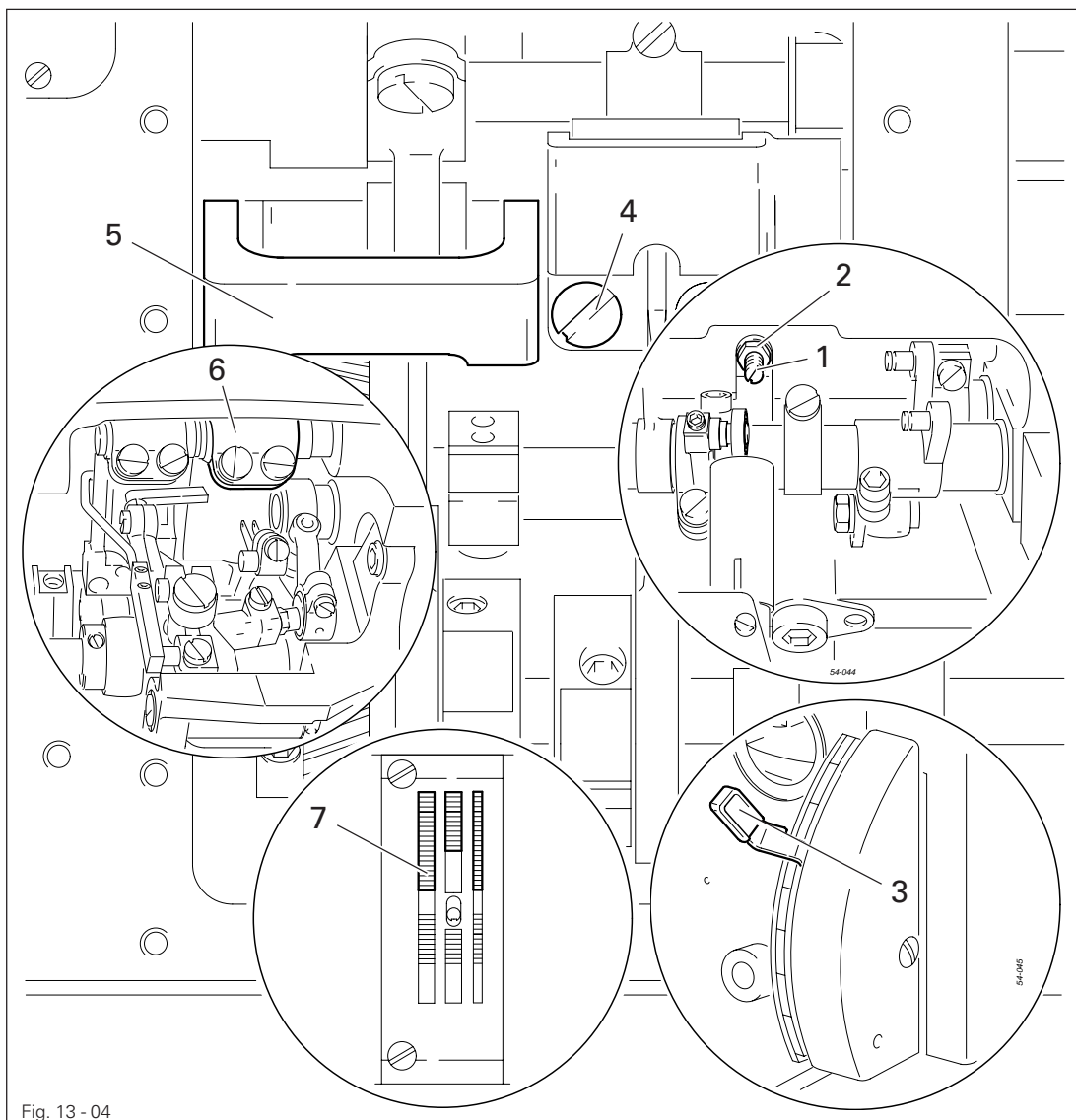
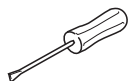

Fig. 13 - 04



- Unscrew screw 1 (nut 2) (stitch length limitation deactivated).
- With adjustment lever 3 set stitch length to "0".
- Loosen screw 4 to such an extent that crank 5 can be moved on the shaft with difficulty.
- While turning the balance wheel continuously, adjust crank 5, so that crank 6 does not move.
- Tighten screw 4.



Screw 1 (nut 2) remains loosened for further adjustments.
(Stitch length limitation is still deactivated).

13.05.05 Neutral position of the differential feed dog

Requirement

With the stitch length set at "0" and the adjustment gauge 1 fitted, there should be no movement of the differential feed dog 5.

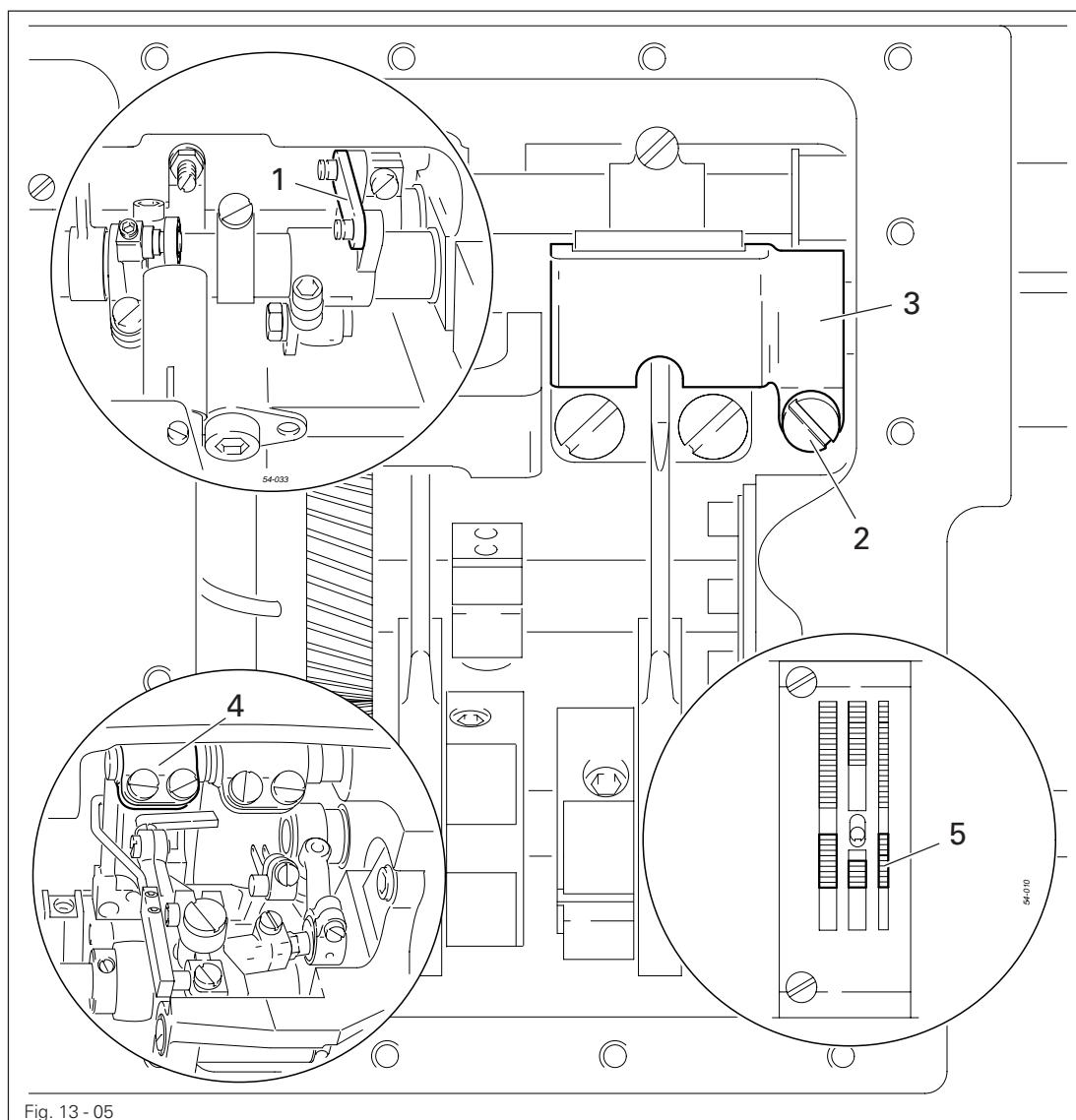
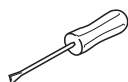

Fig. 13 - 05



- Set stitch length at "0".
- Fit adjustment gauge 1.
- Loosen screw 2 to such an extent that crank 3 can be moved on the shaft with difficulty.
- While turning the balance wheel continuously, adjust crank 3, so that crank 4 does not move.
- Tighten screw 2.



Adjustment gauge 1 remains fitted for further adjustments.

13.05.06 Feeding motion of the main feed dog and the differential feed dog

Requirement

When the stitch length is set at "4", the needle bar is positioned 0.8 before t.d.c. (adjustment hole 4) and the adjustment gauge 8 is fitted, the main feed dog and the differential feed dog should not move when roller 5 is operated.

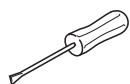
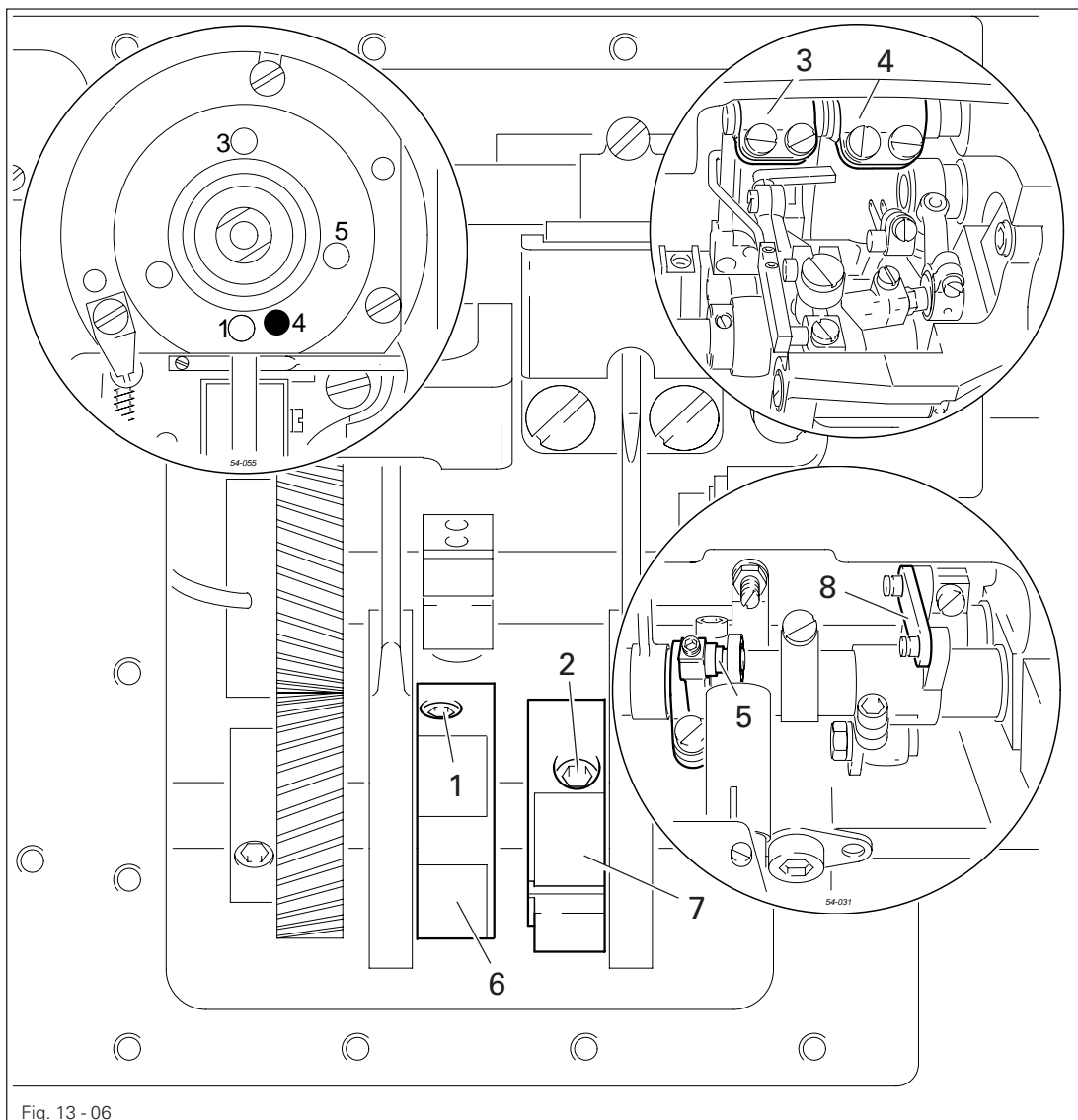

- Slightly loosen screws 1 and 2 (4 screws).
- Bring needle bar to 0.8 before t.d.c. and adjust stitch length to "4".
- While moving roller 5 up and down continuously, turn eccentrics 6 and 7 so that the cutout is visible and the cranks 3 and 4 do not move.
- Tighten screws 1 and 2.

13.05.07 Lifting motion of the main feed dog and differential feed dog (only on the PFAFF 3811-3/55)

Requirement

When the needle bar is at t.d.c. (adjustment hole 1), the cutouts of eccentrics 3 and 4 should point straight down.

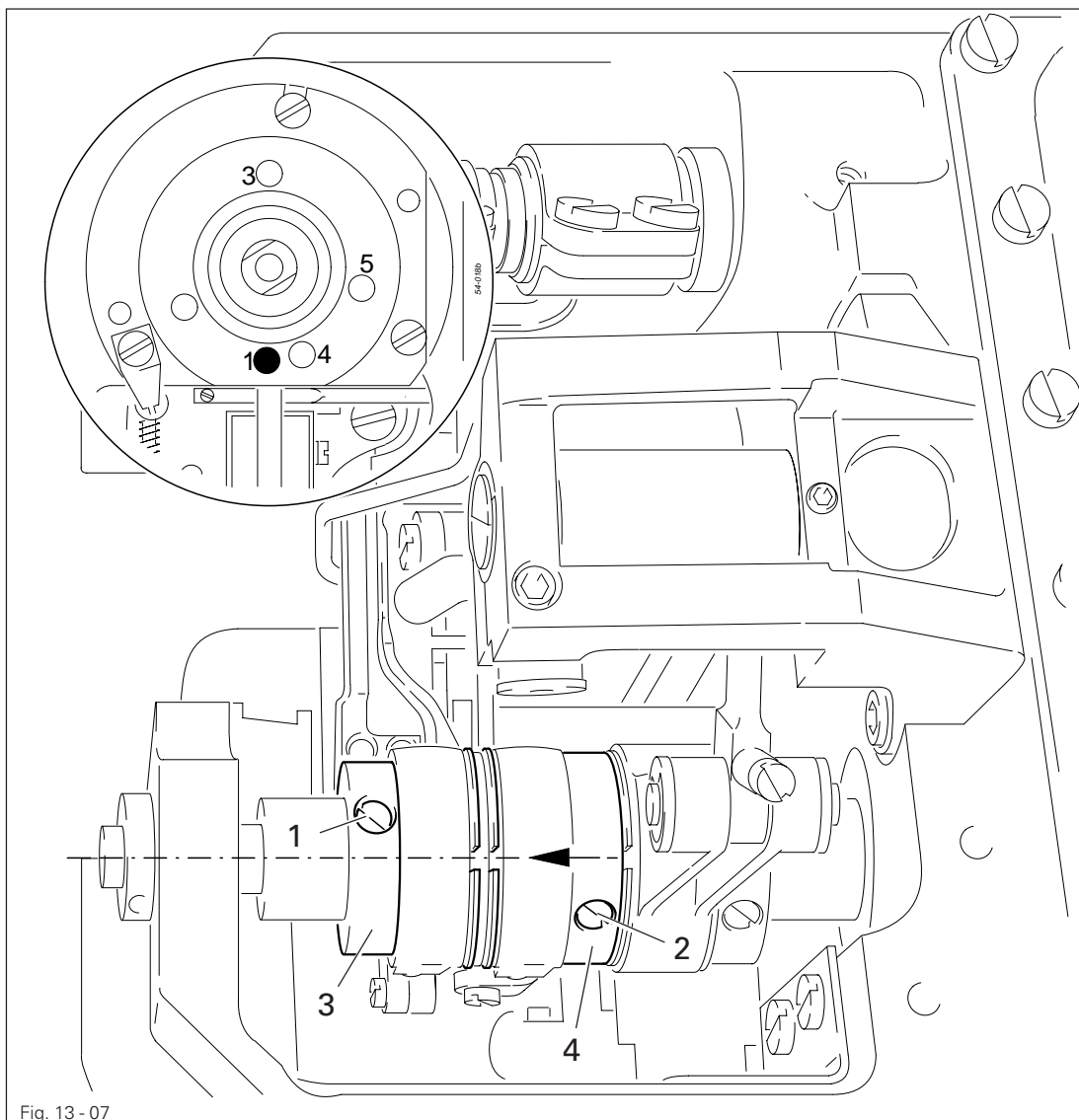
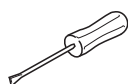

Fig. 13 - 07



- Loosen screws 1 and 2 (4 screws).
- Bring needle bar to t.d.c.
- Turn eccentrics 3 and 4 according to the **requirement** and tighten accessible screws 1 and 2.
- By turning the balance wheel, provide access to the remaining screws 1 and 2 and tighten them.

Adjustment

13.05.08 Lifting motion of the main feed dog

Requirement

When the needle bar is at t.d.c. (adjustment hole 1), the cutout of eccentric 2 should point straight down.

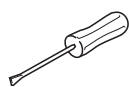
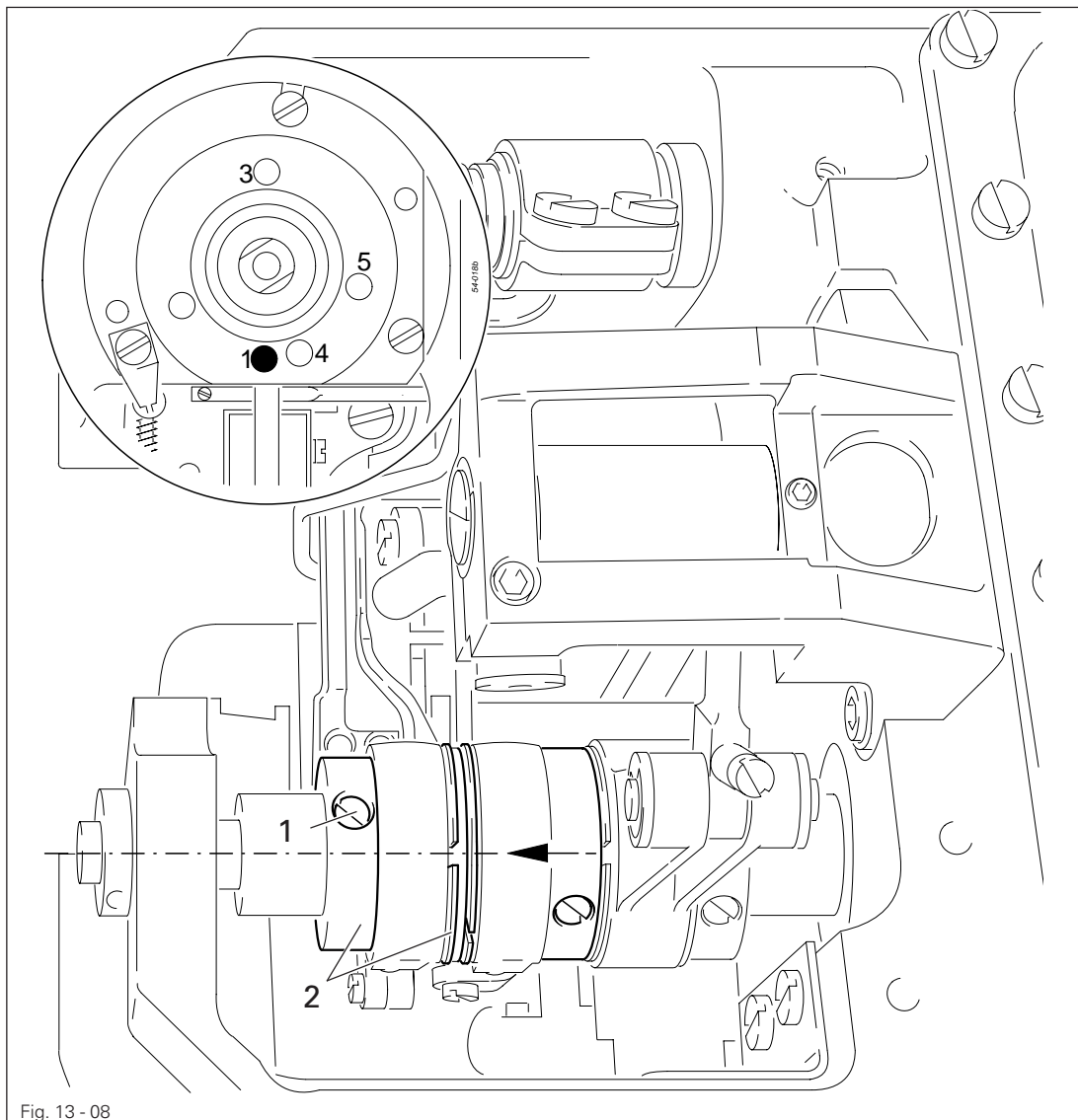

- Loosen both screws 1.
- Bring needle bar to t.d.c.
- Turn eccentric 2 according to the **requirement** and tighten accessible screw 1.
- By turning the balance wheel, provide access to the other screw 1 and tighten it.

13.05.09 Lifting motion of the differential feed dog

Requirement

With the needle bar positioned 5.5 mm before t.d.c. (adjustment hole 5), the cutout of eccentric 2 should point straight down.

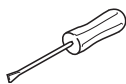
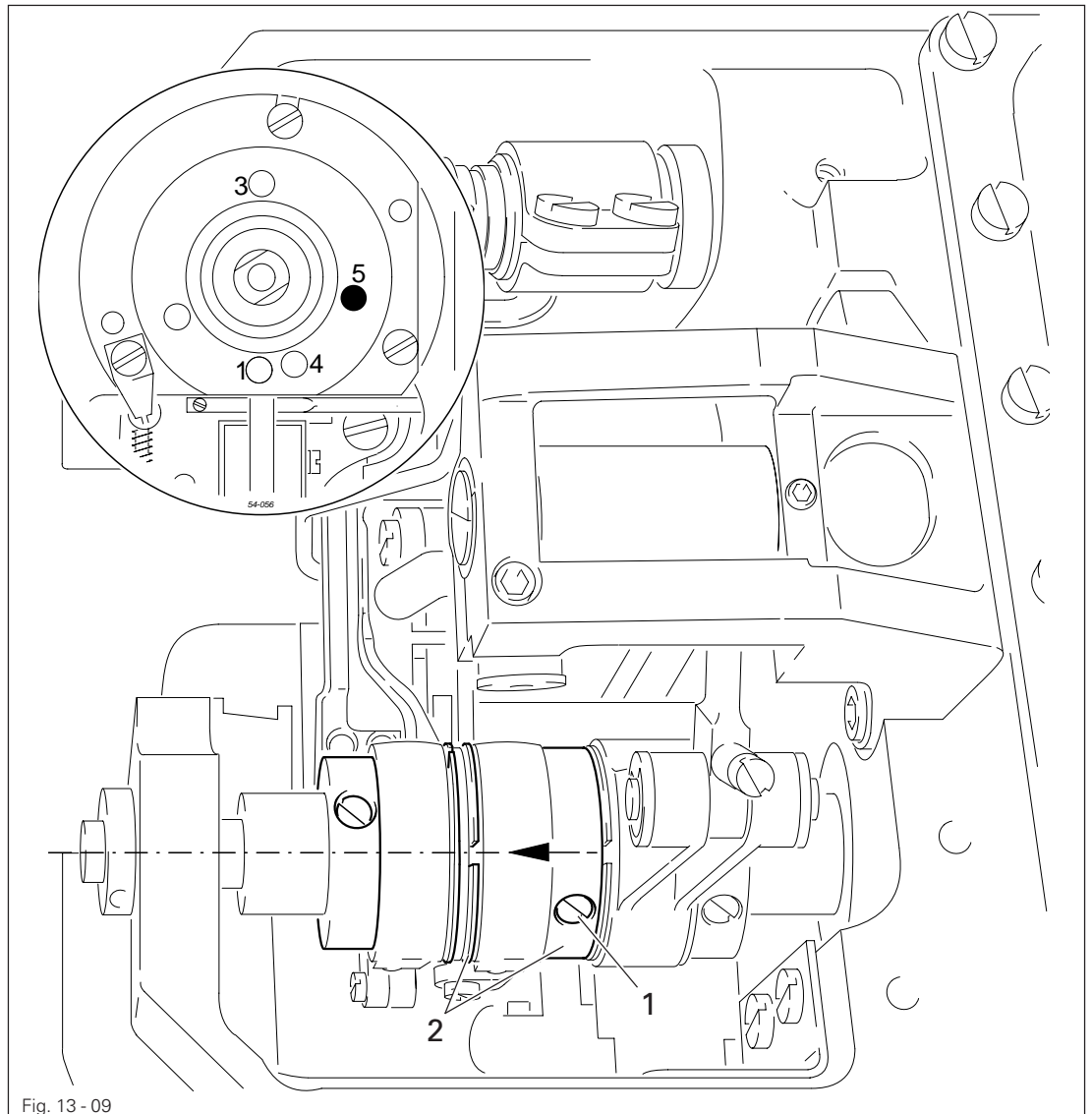

- Loosen both screws 1.
- Bring needle bar to 5.5 mm before t.d.c.
- Turn eccentric 2 according to the **requirement** and tighten accessible screw 1.
- By turning the balance wheel, provide access to the other screw 1 and tighten it.

13.05.10 Position of the main and the differential feed dog on the PFAFF 3811-3/55

Requirement

With the needle bar at t.d.c (adjustment hole 1) and the longest stitch length set

1. The main feed dog should be **1.4 mm** parallel and the differential feed dog **1.9 mm** parallel above the needle plate.
2. Both feed dogs should be in the centre of the needle plate cutout and
3. be **4 mm** apart.

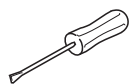
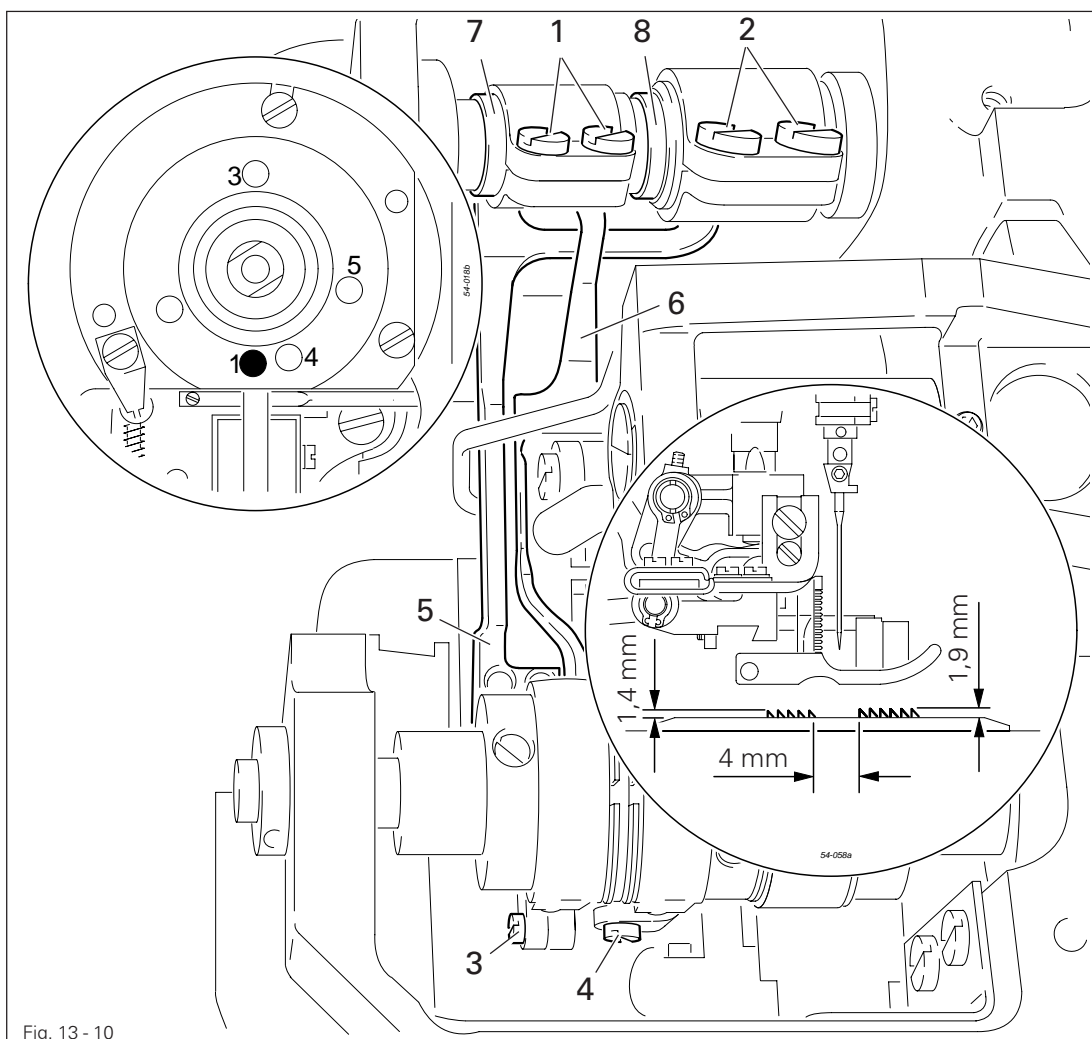

- Bring needle bar to t.d.c. and set the longest stitch length.
- Loosen screws **1, 2, 3** and **4**.
- Adjust feed dog carriers **5** and **6** according to **requirement 1**.
- Slightly tighten screws **1** and **2**.
- Turn eccentric bushes **7** and **8** according to **requirement 2** and **3**.
- In this position tighten screws **3** and **4**.
- In compliance with **requirement 1** tighten screws **1** and **2**.

13.05.11 Position of the main and the differential feed dog on the PFAFF 3811-15/65 and -16/65

Requirement

With the longest stitch length set and in their highest position

1. The main feed dog should be **1.7 mm** and the differential feed dog **2.0 mm** parallel above the needle plate.
2. Both feed dogs should be in the centre of the needle plate cutout and be **approximately 4 mm** apart.

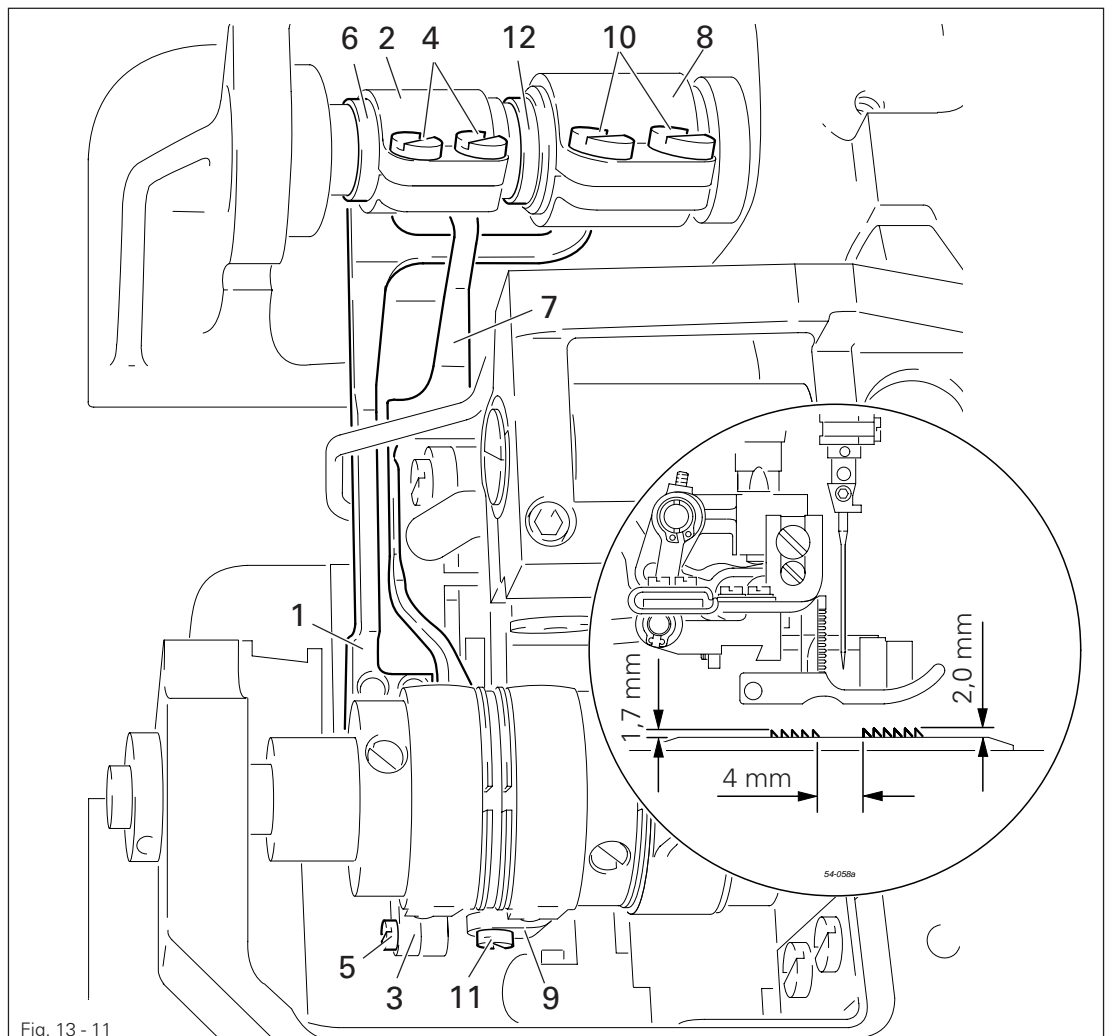
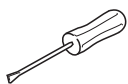

Fig. 13 - 11



- Set the longest stitch length and bring the main feed dog into its highest position.
- According to **requirement 1** and **2**, adjust carrier **1** of the main feed dog by turning crank **2** and **3** (screws **4** and **5**) as well as the eccentric clamp bush **6**.
- Bring differential feed dog carrier **7** into its highest position.
- According to **requirement 1** and **2**, adjust differential feed dog by turning crank **8** and **9** (screws **10** and **11**) as well as the eccentric clamp bush **12**.

13.05.12 Neutral position of the top feed dog

Requirement

When the stitch length is set at "0" and with the adjustment gauge 4 fitted, there should be no feeding motion of the top feed dog.

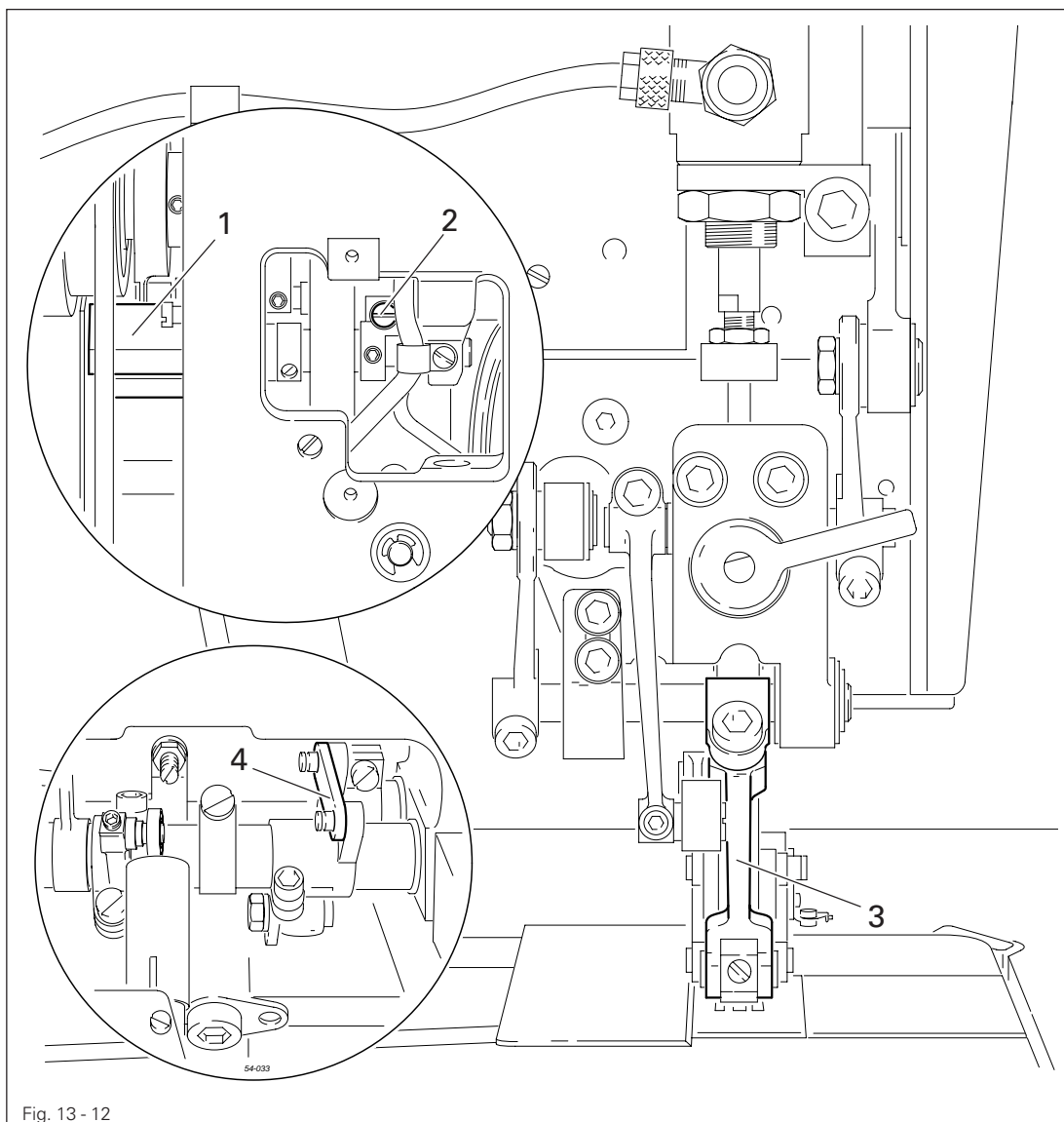

The stitch length limitation (screw 1 in Chapter 13.05.04 Neutral position of the main feed dog) must be deactivated.



- Set stitch length at "0".
- While continuously turning the balance wheel, turn crank 1 (screw 2) so that lever 3 does not move.

13.05.13 Front linkage rod to top feed drive

Requirement

With the needle bar positioned 0.8 before t.d.c. (adjustment hole 4), there must be a distance of approx. **16.5 mm** between the eye of the linkage rod 2 and machine case 3.

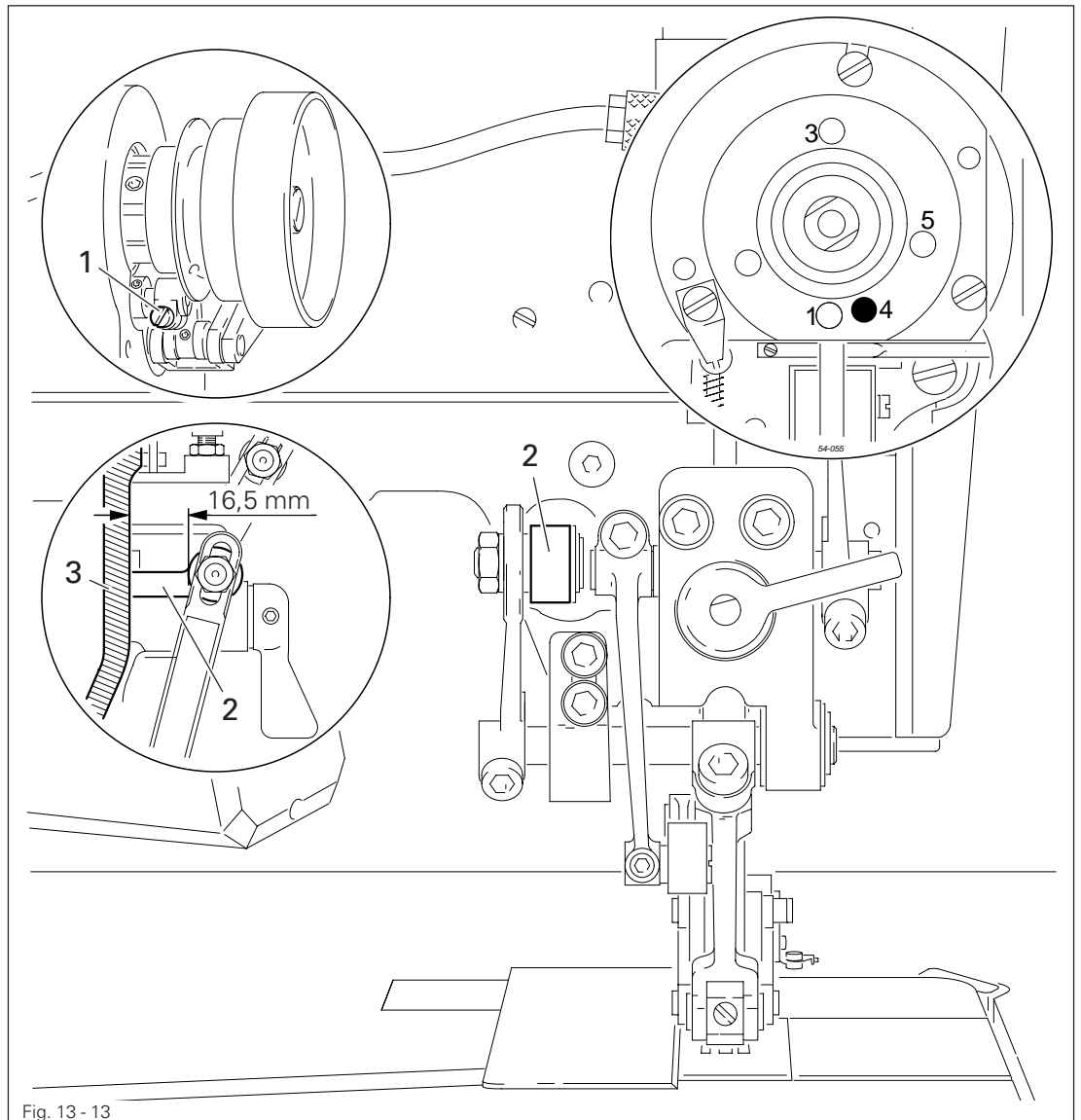
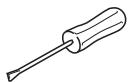

Fig. 13 - 13



- Bring needle bar to 0.8 before t.d.c..
- Loosen screw 1.
- Adjust linkage rod 2 according to the **requirement**.
- Tighten screw 1.
- Check the setting.

13.05.14 Aligning the presser foot

Requirement

1. With the hand lever **1** raised, there should be a clearance of **5 mm** between the presser foot **13** and the needle plate.
2. The needle should penetrate the presser foot **13** in the centre of the needle hole.
3. The presser foot edge should be parallel to the bottom feed dog.

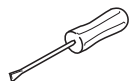
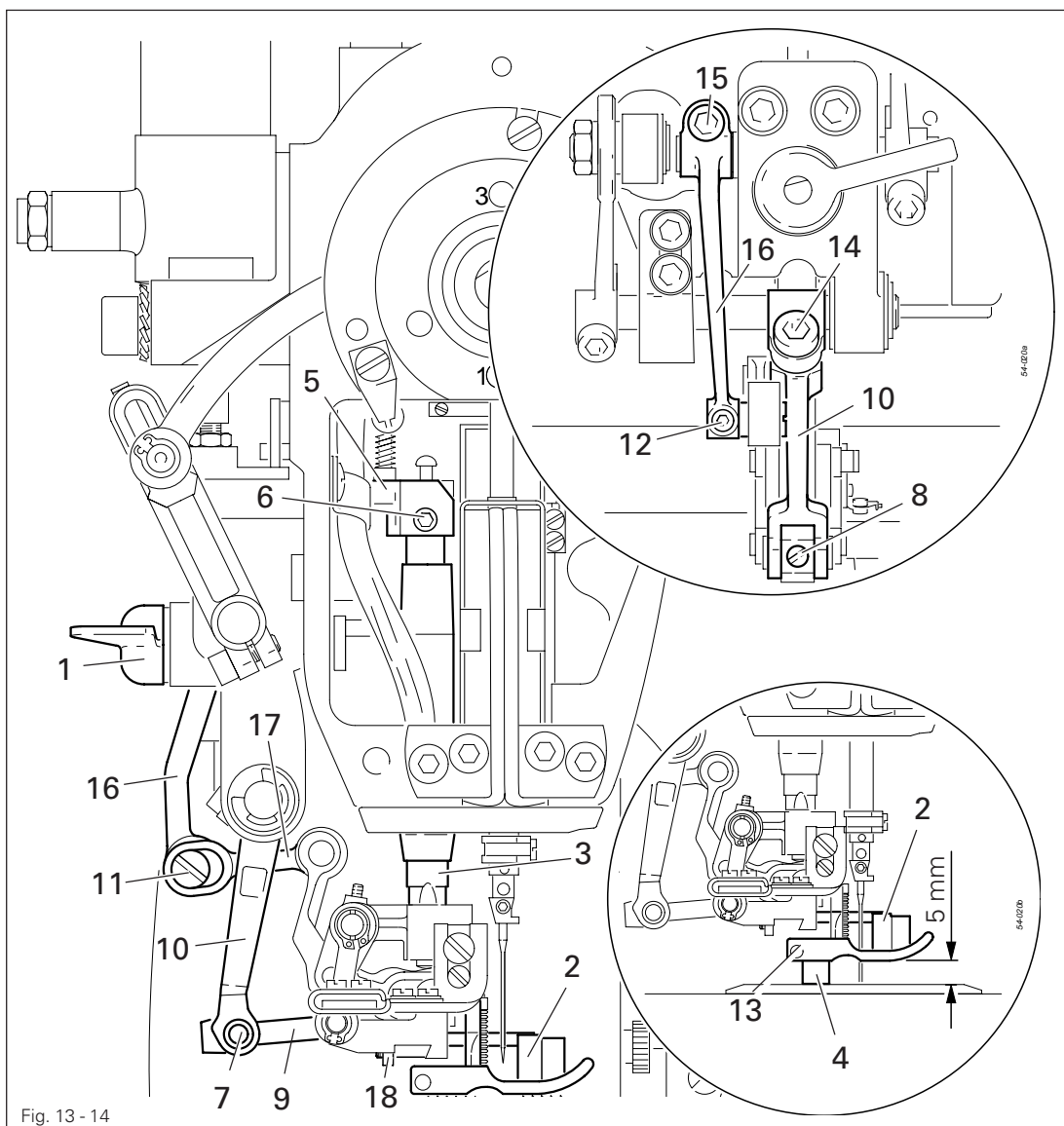

- Raise hand lever **1**.
- By turning the balance wheel, bring top feed dog **2** to its t.d.c.
- Raise presser rod **3** and from the rear insert the 5 mm thick part of adjustment gauge **4** (part no. 61-111 642-19) under the presser foot.
- Lower presser rod lifter **5** (screw **6**) as far as possible.
- Remove pin **7** (screw **8**).
- Disengage lever **9** from lever bracket **10**.
- Remove eccentric pin **11** (screw **12**).
- Align presser foot **13** according to the requirements.

- Tighten screw **6**.
- Remove adjustment gauge **4** and let presser foot **13** rest on the needle plate.
- Loosen screw **14**.
- Engage lever **9** in lever bracket **10**.
(Lever **9** must move smoothly. If not, adjust lever **10**).
- Insert pin **7** (screw **8**), paying attention to smooth running.
- If necessary adjust lever **10**.
- Bring needle bar to 0.8 before t.d.c.
- Bring top feed dog **2** in sewing direction into the centre of the presser foot cutout and tighten screw **14**.
- Loosen screw **15**.
- Connect lever **16** to the linkage rod **17** with eccentric pin **11** (screw **12**), placing eccentric pin **11** with its greatest eccentricity pointing downwards.
- Bring lever **16** into contact with eccentric pin **11** and tighten screw **15**.
- Align top feed dog **2** (screw **18**) so that its side does not touch presser foot **13**.



All moving parts of the top feed drive must run smoothly and without any backlash.

Lubricate the joints at regular intervals, see **Chapter 12.03 Lubricating the top feed joints**.

Adjustment

13.05.15 Feeding motion of the top feed dog

Requirement

With the stitch length set at "4", the needle bar positioned 0.8 mm before t.d.c. (adjustment hole 4), lever 4 should not move when lever 2 is operated.

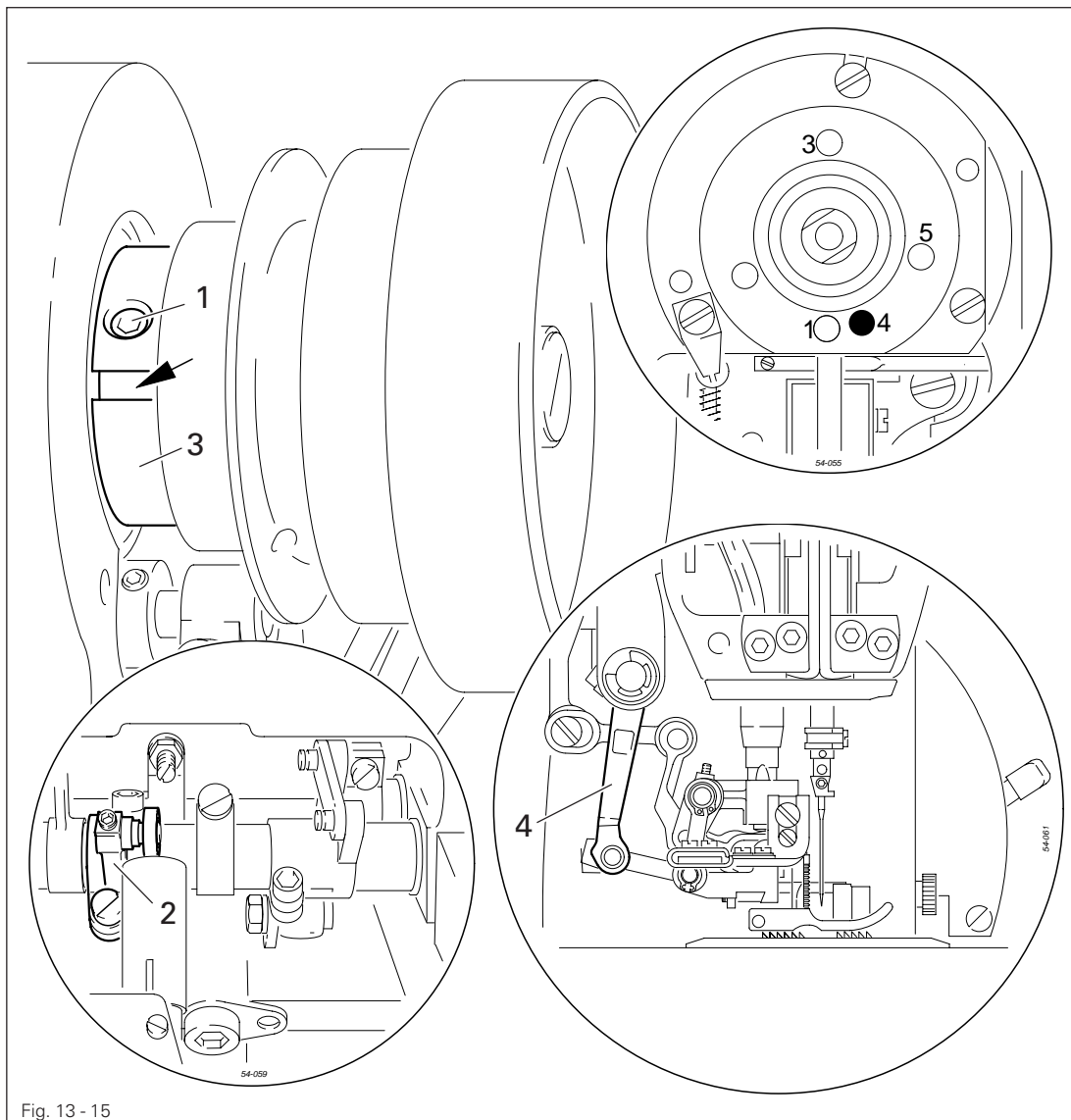
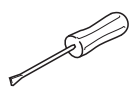

Fig. 13 - 15



- Loosen both screws 1.
- While continuously moving lever 2 up and down, adjust eccentric 3, so that the slot is pointing towards the operator and lever 4 does not move.
- Tighten screws 1.

13.05.16 Top feed stroke

Requirement

With the stitch length set at "4" and adjustment gauge 12 fitted, at t.d.c. the top feed dog 2 should be 3.2 mm.

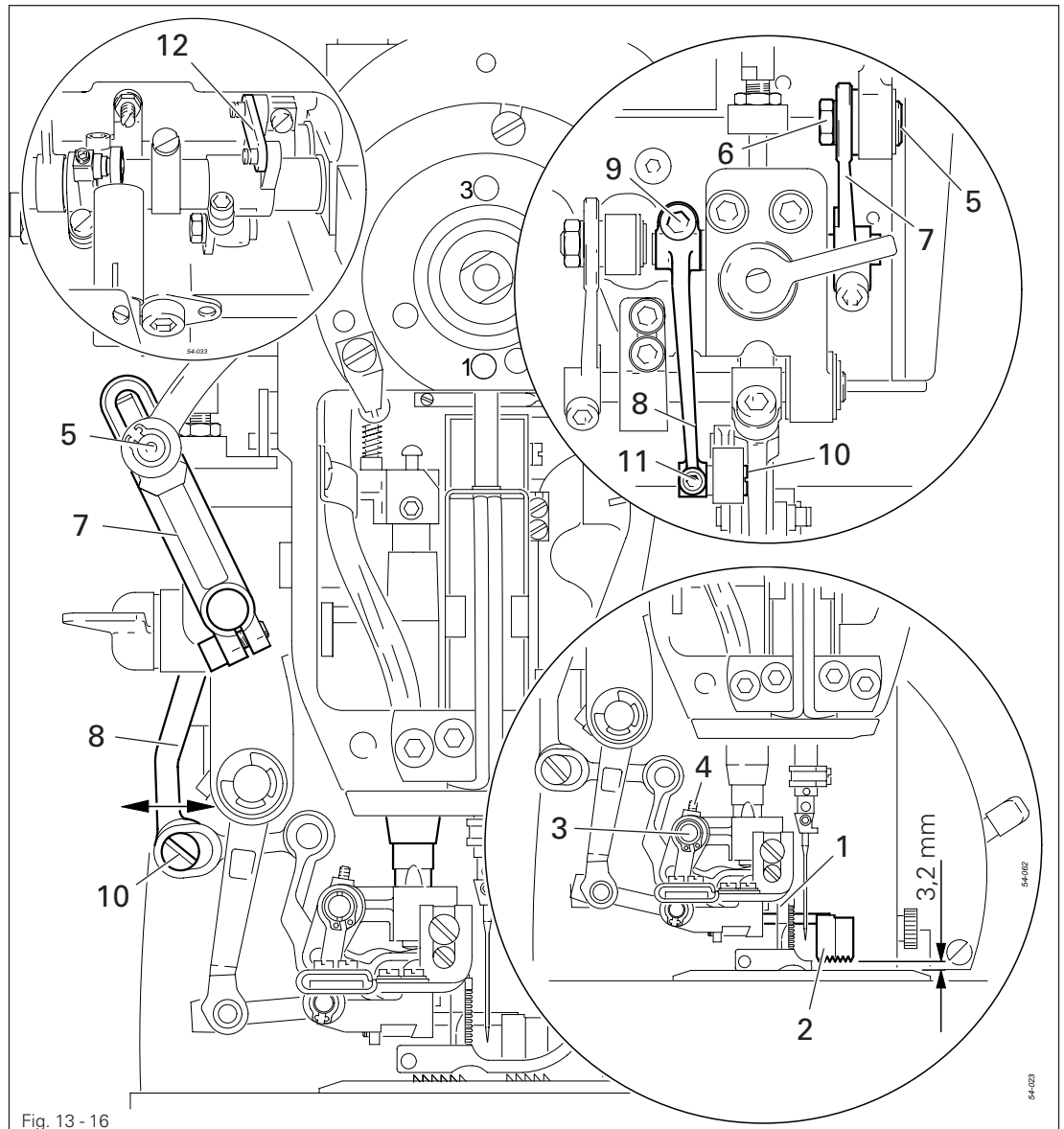
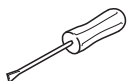

Fig. 13 - 16



- Allow the presser foot 1 to touch the needle plate.
- Set the stitch length "4".
- By turning the balance wheel bring the top feed dog 2 to t.d.c.
- Adjust the eccentric pin 3 (screw 4) so that its maximum eccentricity is pointing towards the needle.
- Move pin 5 (nut 6) to the bottom of the elongated hole of lever 7.
- To pre-set the distance of the top feed dog 2 from the needle plate adjust lever 8 (screw 9).
- Adjust eccentric pin 10 (screw 11) in accordance with the **requirement**.

13.05.17 Lifting motion of the top feed dog

Requirement

When the stitch length is set at "4" and with adjustment gauge **3** fitted, the top feed dog should rest on the ascending bottom feed dog, when this reaches the top edge of the needle plate.

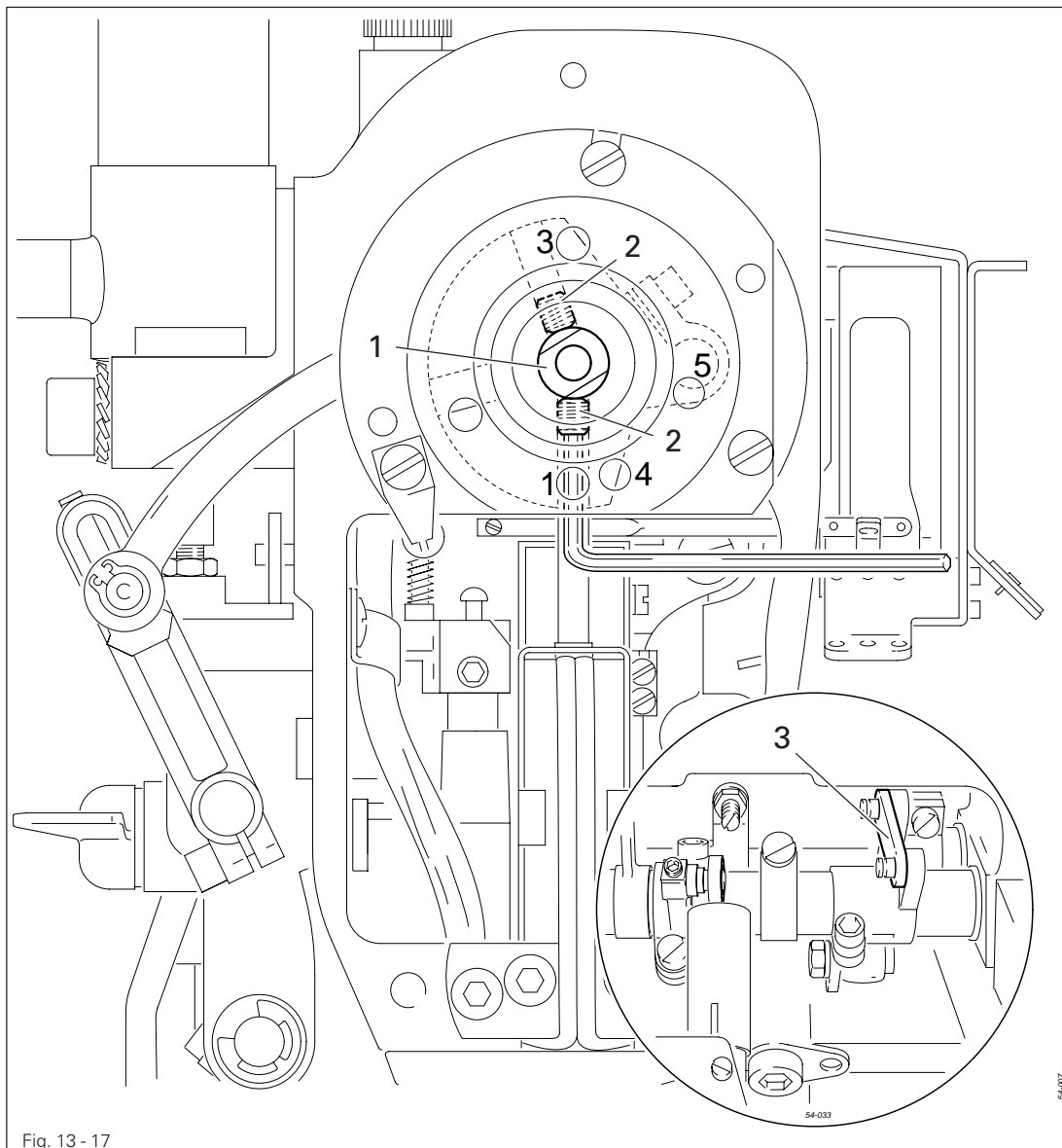
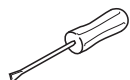

Fig. 13 - 17



- Set stitch length to "4".
- Adjust eccentric **1** (screws **2**) according to the **requirement**.

13.05.18 Stitch length limitation

Requirement	
3811 -3/55	<ol style="list-style-type: none"> 1. The bottom stroke of rocking bar 6 should be set so that the stitch length is 2.2 mm ($x = 22 \text{ mm}$ with 11 penetrations). 2. With the same stitch length set, screw 4 should rest lightly on the casting. (It should no longer be possible to move rocking bar 6).
3811 -15/65 -16/65	<ol style="list-style-type: none"> 1. The bottom stroke of rocking bar 6 should be set so that the stitch length is 4.2 mm ($x = 42 \text{ mm}$ with 11 penetrations). 2. The top stroke of rocking bar 6 should be set so that the stitch length is 3.1 mm ($x = 31 \text{ mm}$ with 11 penetrations).

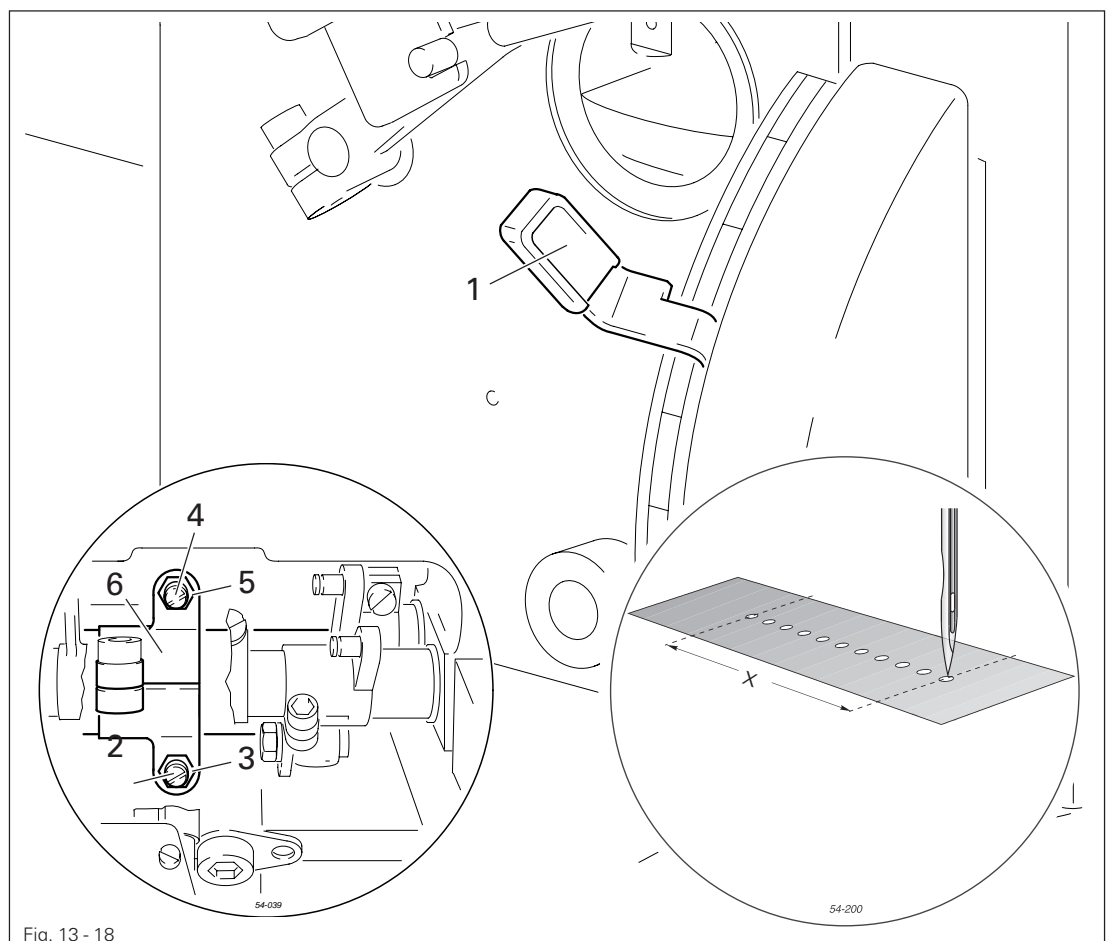
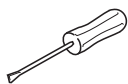

Fig. 13 - 18



- Set the stitch length on lever 1 according to **requirement 1**.
- Adjust screw 2 (nut 3) according to **requirement 1**.
- Set the stitch length on lever 1 according to **requirement 2**.
- Adjust screw 4 (nut 5) according to **requirement 2**

13.05.19 Basic setting of the differential adjustment mechanism

Requirement	
3811 -3/55	With the fullness set at "0", the stitch length at "2.2" and the adjustment gauge 5 fitted, the roller 2 should be touching pressure sleeve 4.
3811-15/65 -16/65	With the fullness set at its highest level "key 15", the stitch length set at "4" and the adjustment gauge 5 fitted, the roller 2 should be 6.1 mm from pressure sleeve 4.

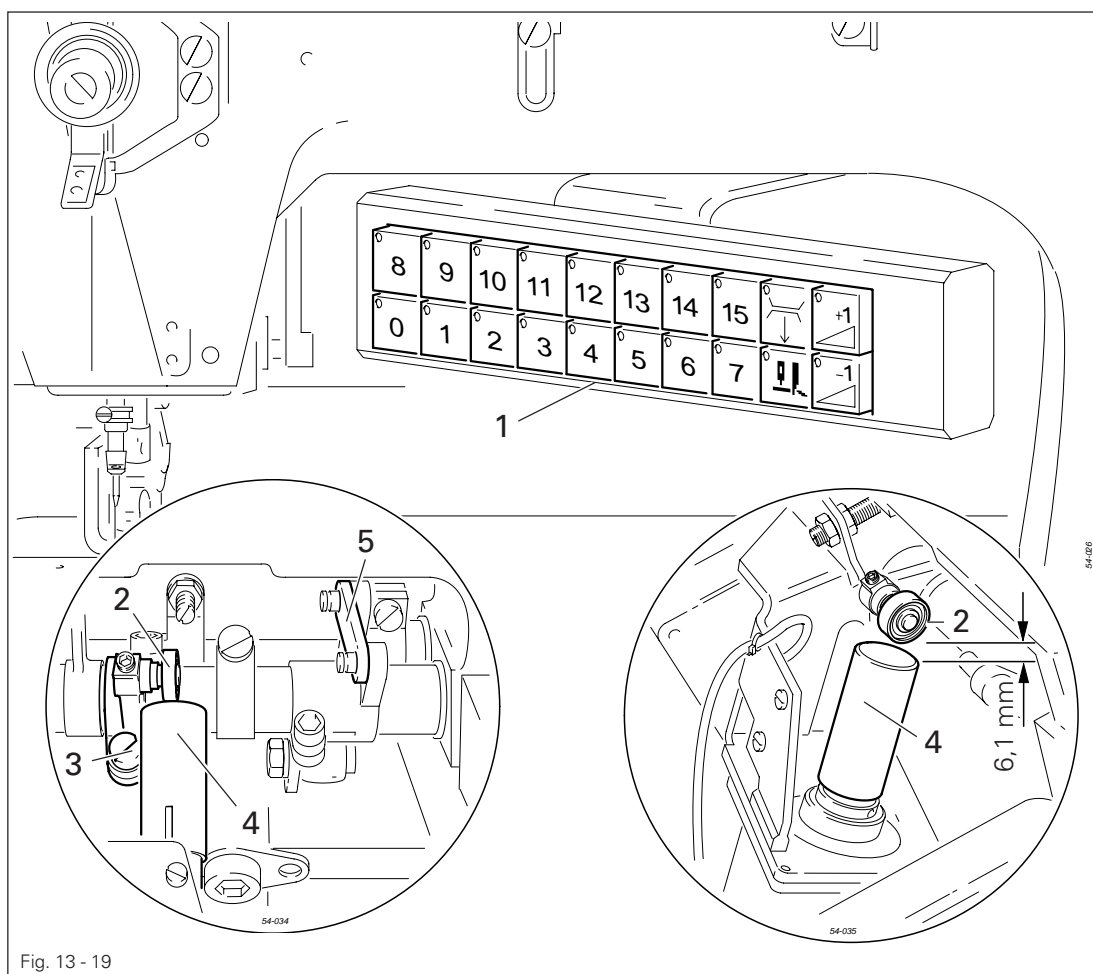
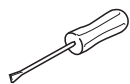

Fig. 13 - 19



- Switch on the machine.
- The following work step is dependent on the type of machine.
PFAFF 3811-15/65, -16/65:
 Press key "15" on keyboard 1 (LED must light up).
PFAFF 3811-3/55:
 Set fullness at "0".
- Switch off the machine.
- Adjust roller 2 (screw 3) according to the requirement.

13.05.20 Setting the standard stitch length (not on the PFAFF 3811-3/55)

Requirement

When the stitch length is set at "3" and key "15" is activated (cylinder 4 completely extended), the stitch length should be 3 mm.

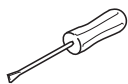
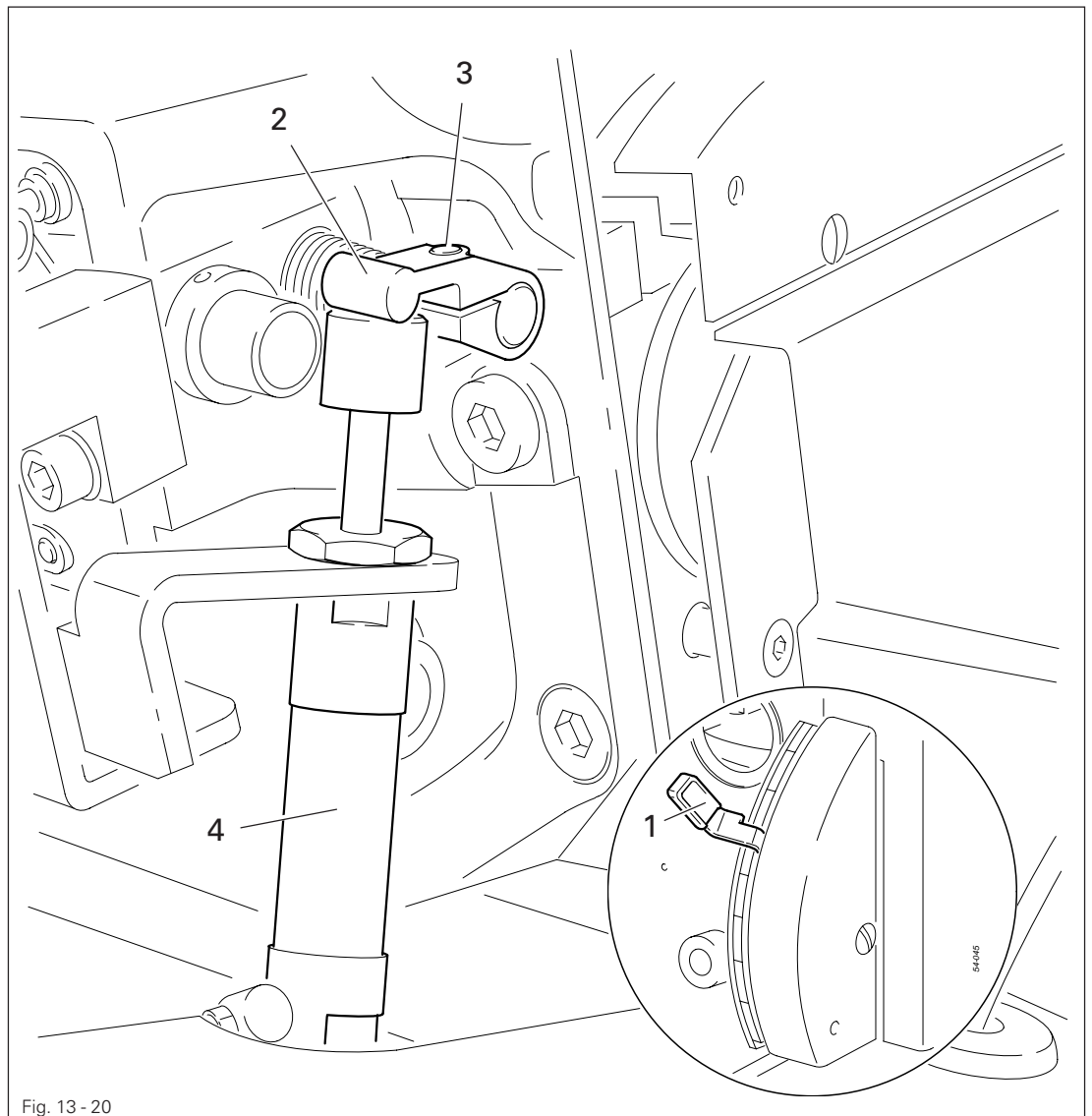

- Set stitch length "3" (lever 1).
- Switch on the machine and press key "15" on the keyboard.
- Adjust crank 2 (screw 3) according to the **requirement**.

Adjustment

13.05.21 Looper avoiding motion

Requirement

With the needle bar at t.d.c. (adjustment hole 1) the cutout of eccentric 2 should be positioned vertically below the centre of the axis.

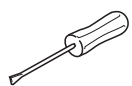
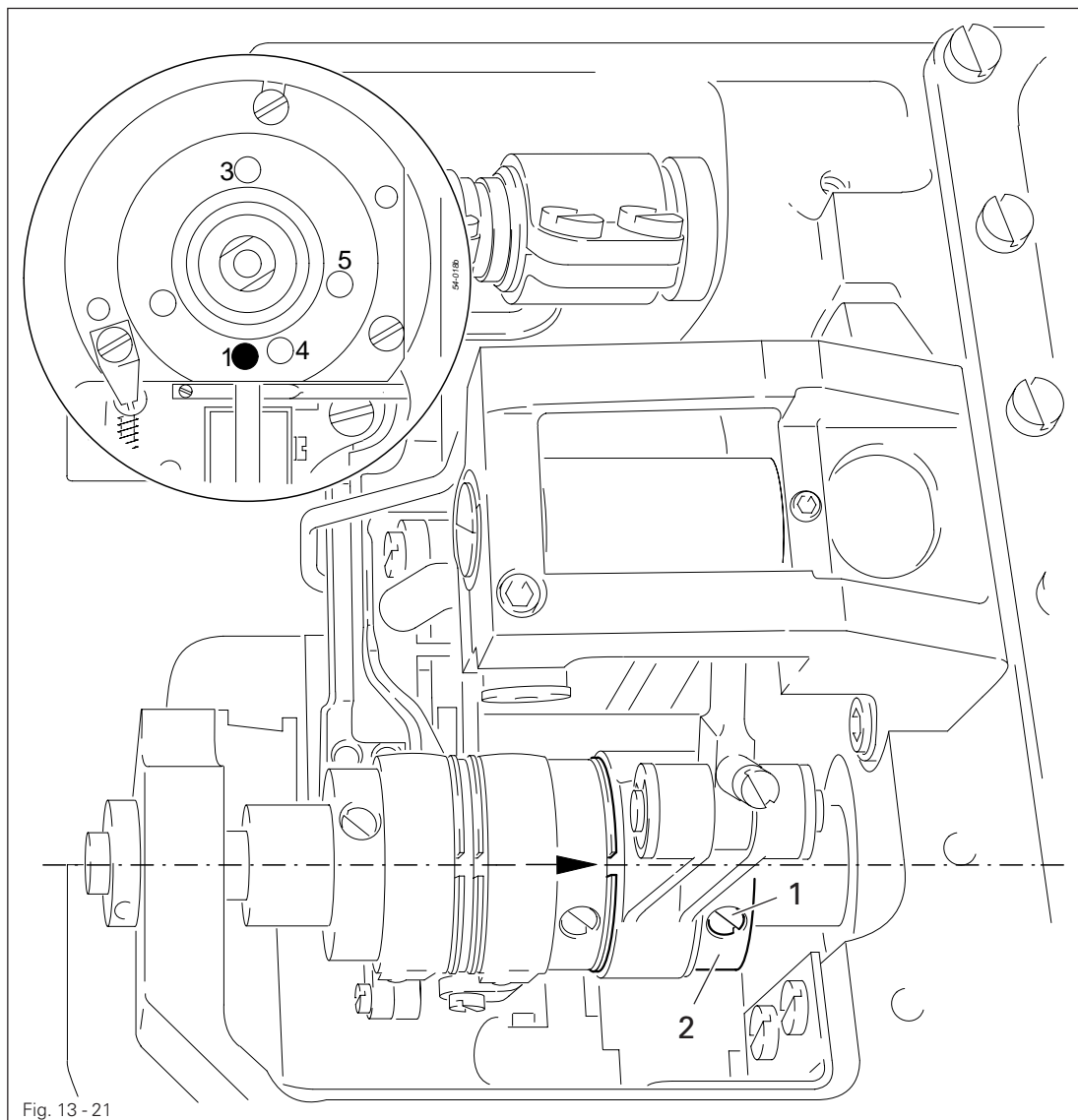

- Loosen both screws 1.
- Bring needle bar to t.d.c.
- Adjust eccentric 2 according to the requirement.
- Tighten screws 1.

13.05.22 Looper motion

Requirement

In the following positions the looper point should be positioned at the same height:

- When, after turning the balance wheel in the sewing direction, the looper point is on the left side of the needle.
- When, after turning the balance wheel back from position a), the looper point is on the right side of the needle.

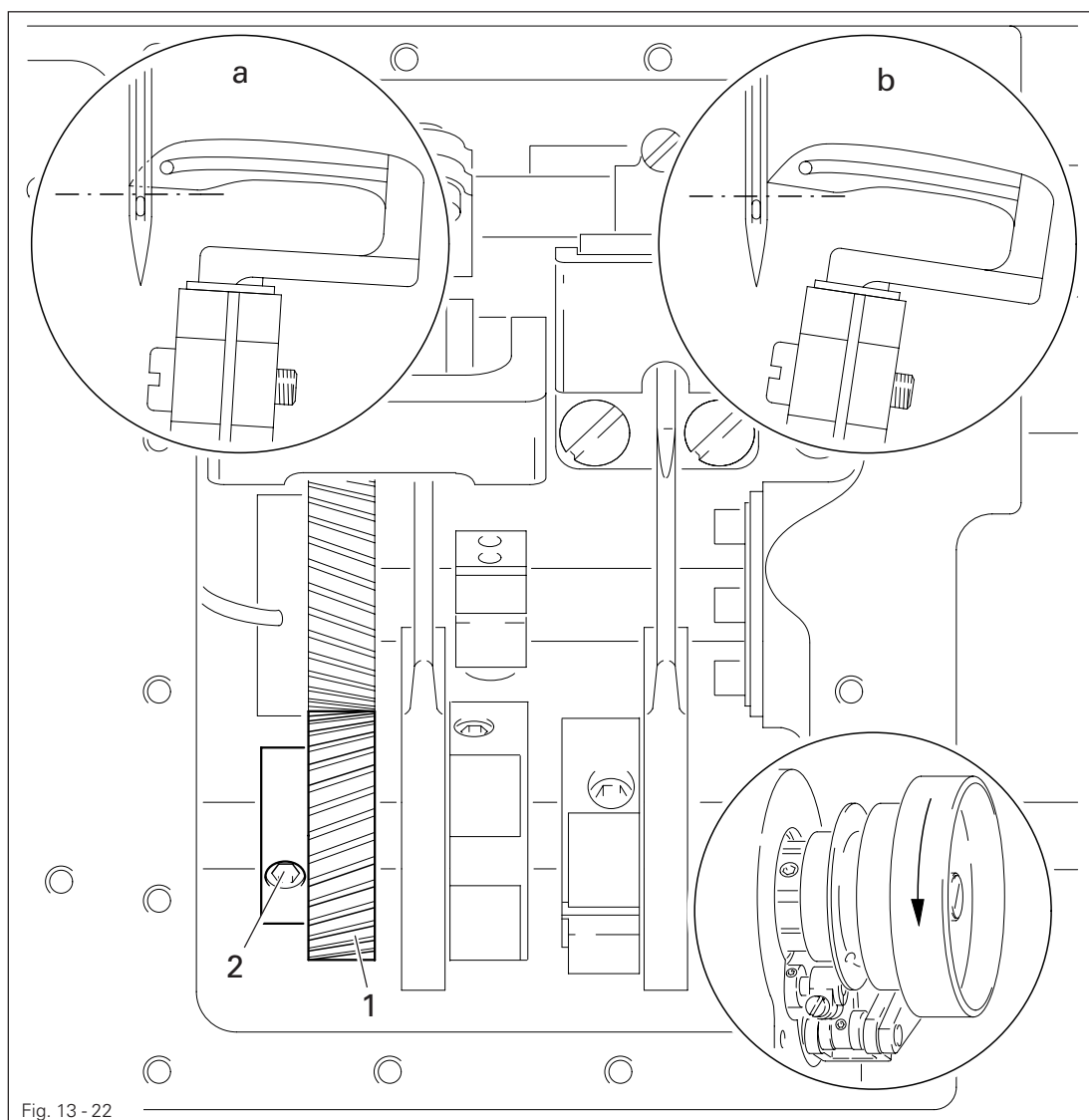
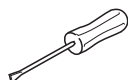

Fig. 13 - 22



- Insert a new needle.
- Turn the balance wheel until the looper point approaching from the right is positioned on the left side of the needle.
- In this position fasten the screw clamp (part no. 08-880 137-00) on the needle bar, so that the upward movement of the needle bar is blocked.
- Turn the balance wheel against the sewing direction, until the screw clamp is touching the needle bar frame again.
- Check **requirement**.
- If necessary, remove the screw clamp and adjust gear 1 (screws 2) according to the **requirement**.

13.05.23 Looper height and looper angle

Requirement

When the looper carrier 2 is in a vertical position there should be

1. a distance of **0.7 mm** between the highest point of the looper back and the needle plate rest and
2. looper 7 should be resting on looper adjustment gauge 9.

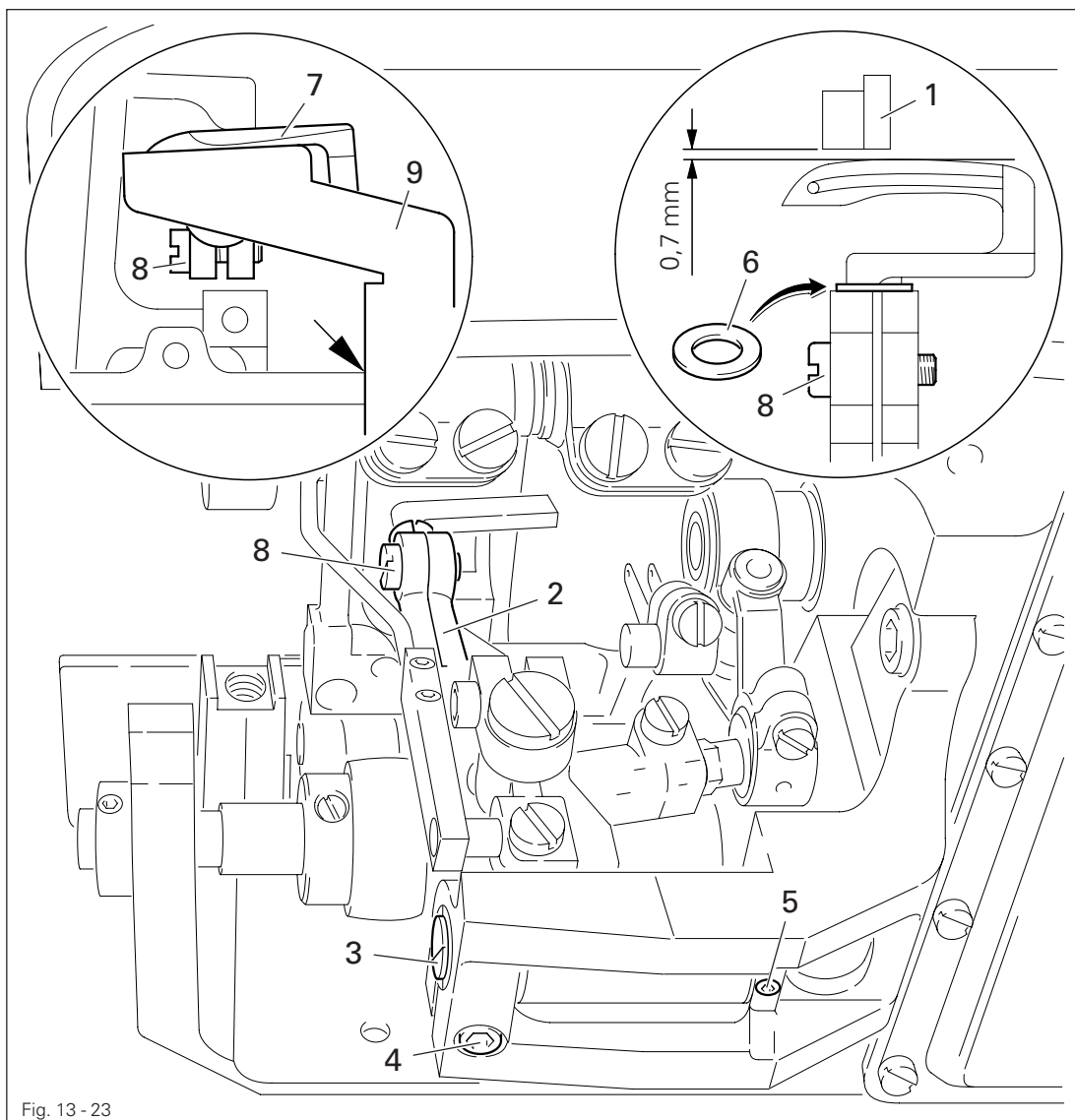
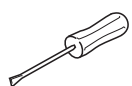

Fig. 13 - 23



- Remove needle plate and bottom feed dog.
- Place adjustment gauge 1 (part no. 61-111 642-19) on the needle plate rest.
- Set looper carrier 2 into a vertical position.
- Adjust eccentric bearing pin 3 (screws 4 and 5) according to requirement 1.
- Check the setting.



If the required distance is not achieved, replace spacer 6. To do so, looper 7 (screw 8) must be removed.

- Place looper adjustment gauge **9** (part no. 61-111 643-06) on the left edge of the cover plate guide (see arrow) and push it against looper **7**.
- Position looper **7** (screw **8**) on the looper adjustment gauge **9** (requirement 2).

Spacer	Part No.
0.3 mm	91-170 693-05
0.5 mm	91-169 614-05
0.8 mm	91-169 615-05
1.2 mm	91-170 694-05

13.05.24 Looper-to-needle clearance in sewing direction

Requirement

In sewing direction there must be a clearance of approx. **0.1 mm** between looper point and needle.

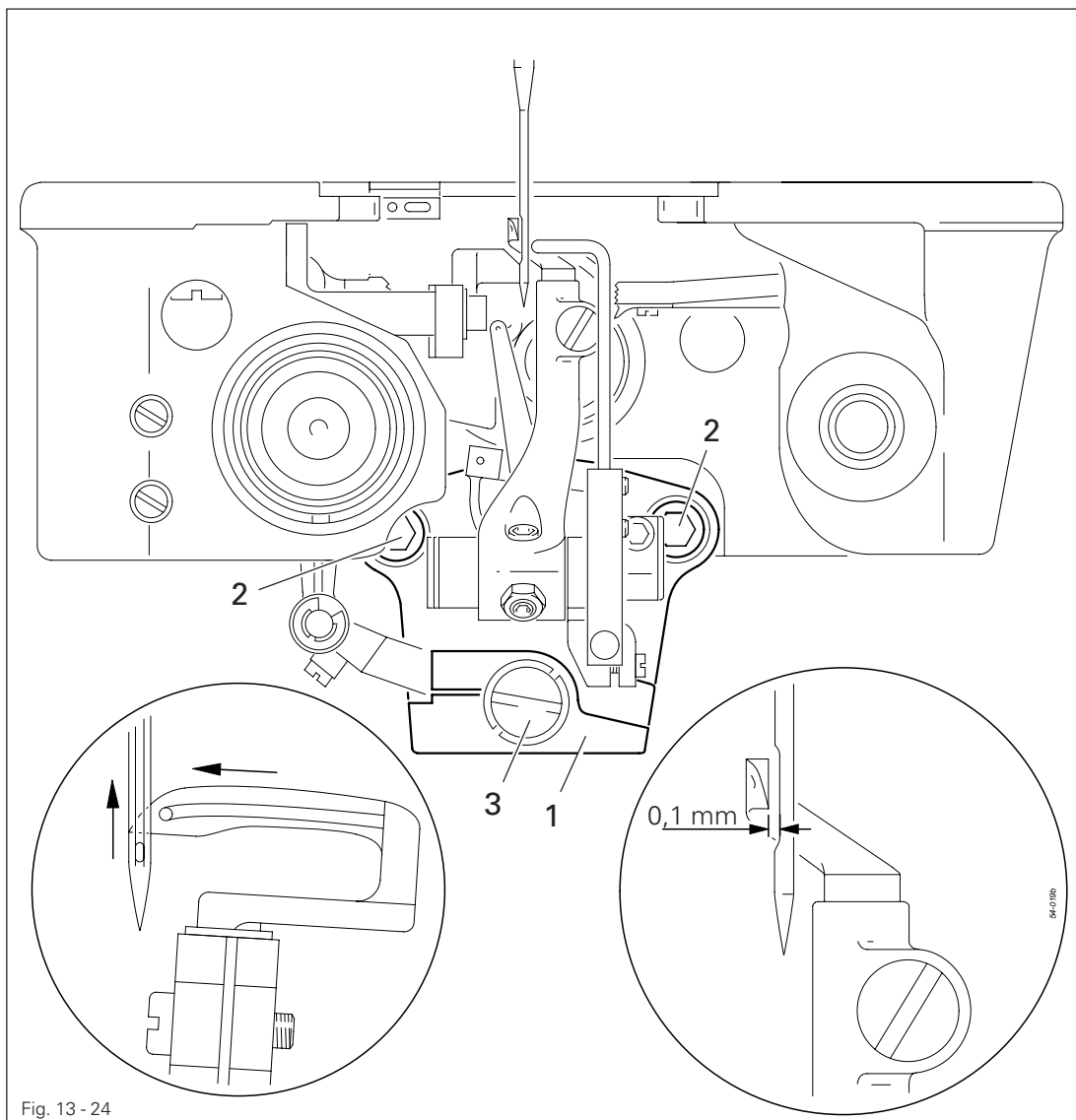
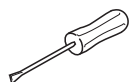

Fig. 13 - 24



- Turn the balance wheel until the looper point coming from the right reaches the left side of the needle.
- Align looper unit 1 (screw 2) according to the **requirement**.



If a clearance of **0.1 mm** cannot be obtained, the setting of the eccentric bearing stud 3 can be corrected. In this case the looper height and angle must be checked, see **Chapter 13.05.24 Looper height and looper angle**.

13.05.25 Looper-to-needle clearance crosswise to sewing direction

Requirement

When the looper **1** is at its right point of reversal, there must be a clearance between the looper point crosswise to the sewing direction and the needle center of **3.6 mm**.

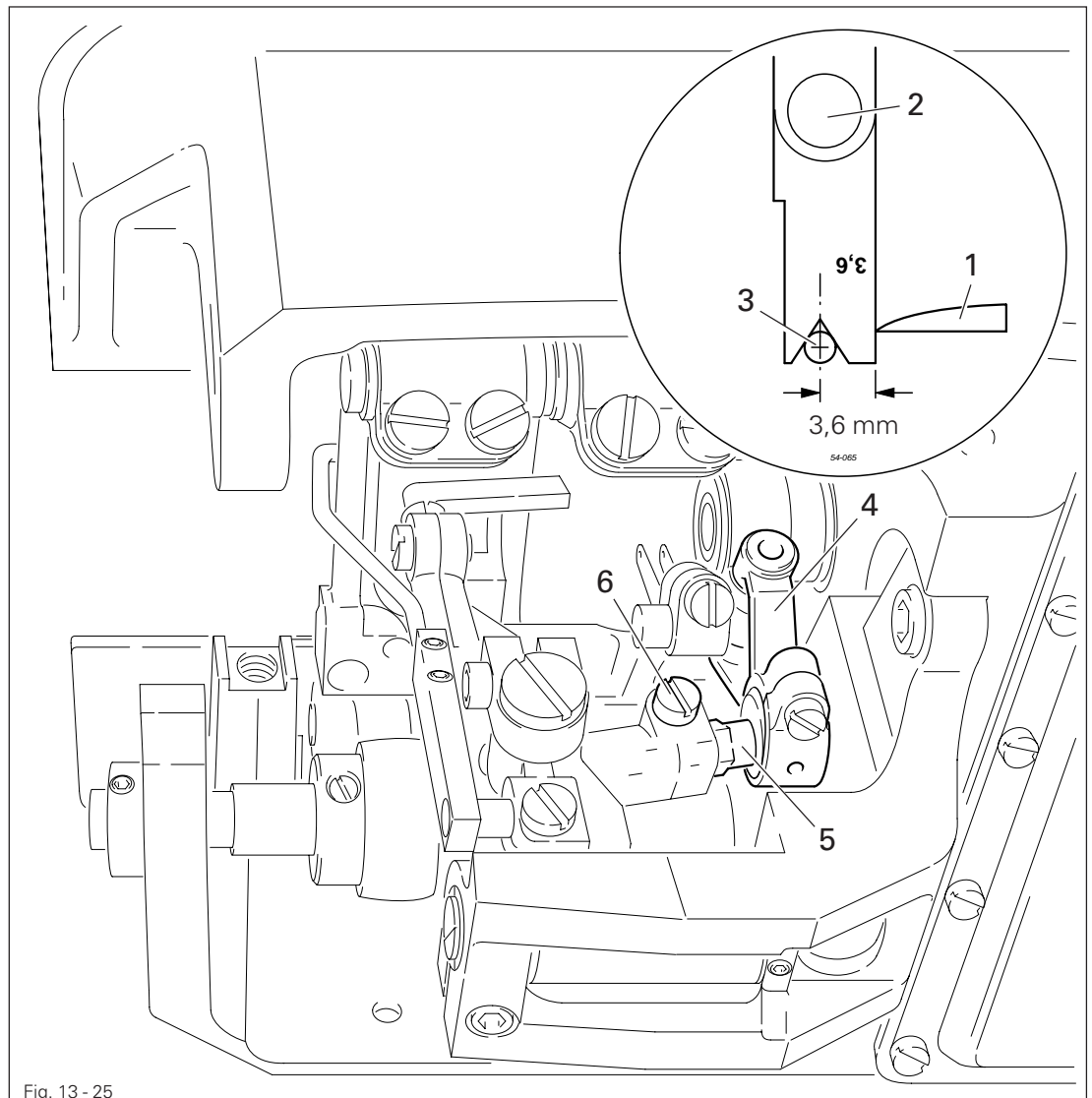
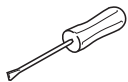

Fig. 13 - 25



- By turning the balance wheel bring the looper **1** to its right point of reversal.
- Place the "3.6" blade of looper gauge **2** (Order No. 61-111 643-06) against the needle **3** with its notch facing the direction of feed.
- Make sure that the driving link **4** is vertical and turn the ball pin **5** (screw **6**) with the aid of an open-ended spanner (size **6**), until the looper point **1** contacts the blade.

13.05.26 Final adjustment of the needle height

Requirement

When the point of the looper advancing from the right reaches the left side of the needle, the top edge of the needle eye must be **1.0 - 1.2 mm** below the bottom edge of the looper.

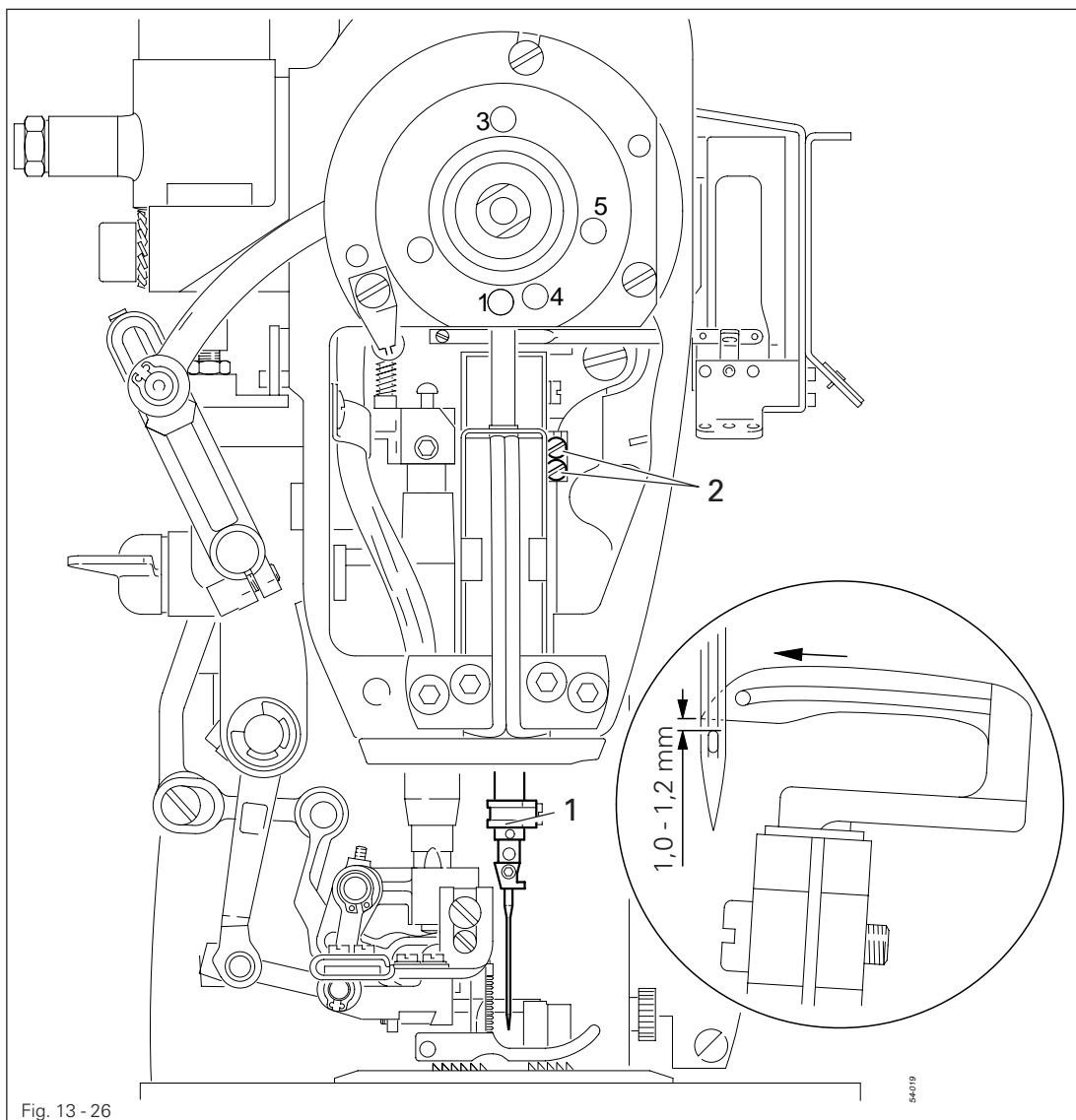
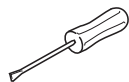

Fig. 13 - 26



- Turn the balance wheel until the looper point, which is coming from the right, reaches the left side of the needle.
- Without turning the needle bar 1 (screw 2) adjust it according to the **requirement**.

13.05.27 Height of rear needle guard

Requirement

When the needle bar is at bottom dead center (pin in hole 3), the vertical surface of the needle guard 1 must cover about $\frac{2}{3}$ of the needle eye.

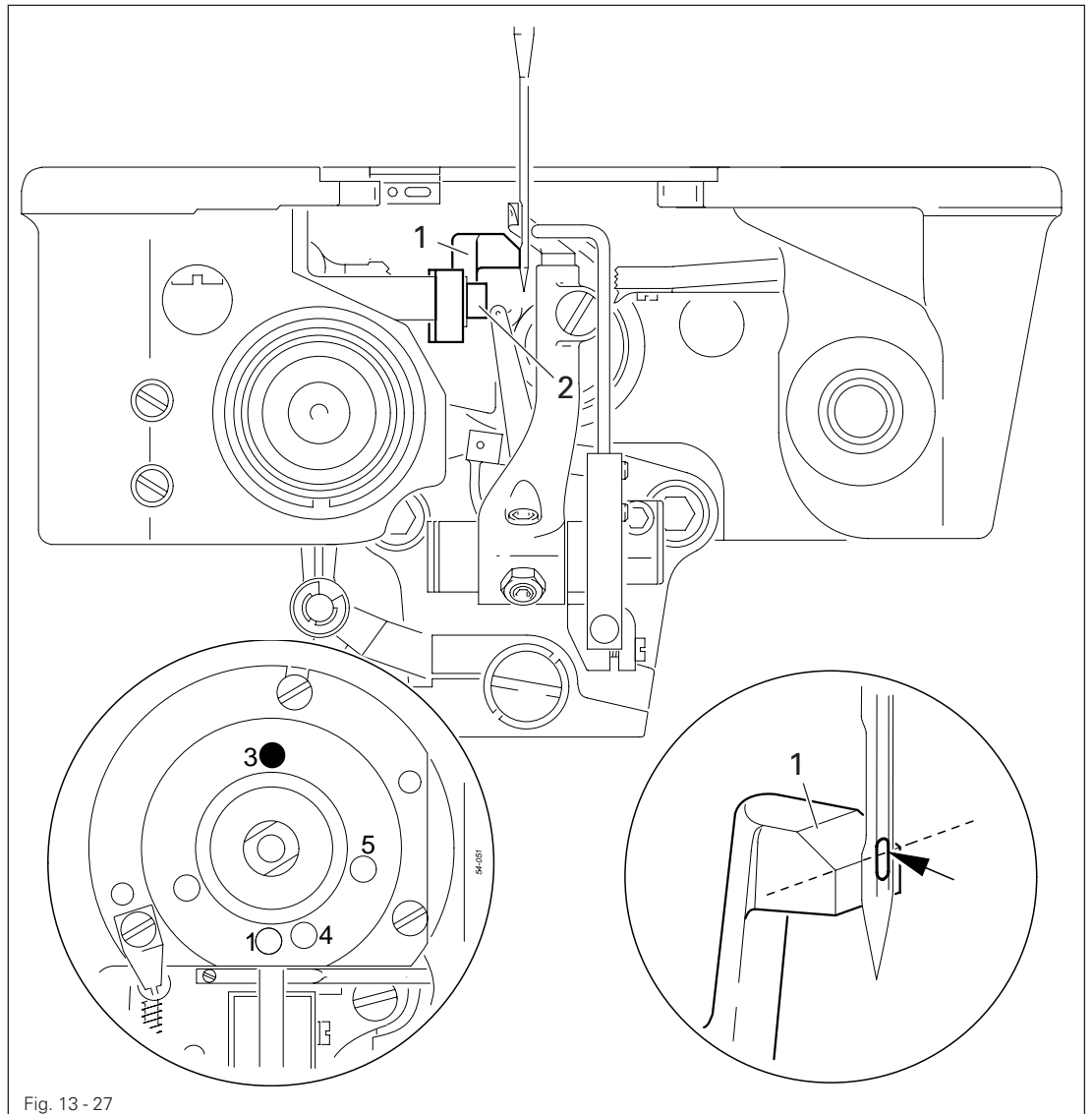
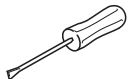

Fig. 13 - 27



- Bring the needle bar to BDC.
- Adjust needle guard 1 (screw 2) according to the requirement.

13.05.28 Clearance between rear needle guard and needle

Requirement

When the point of the looper, which is advancing from the right, reaches the right side of the needle, the needle guard **3** must still be in slight contact with the needle.

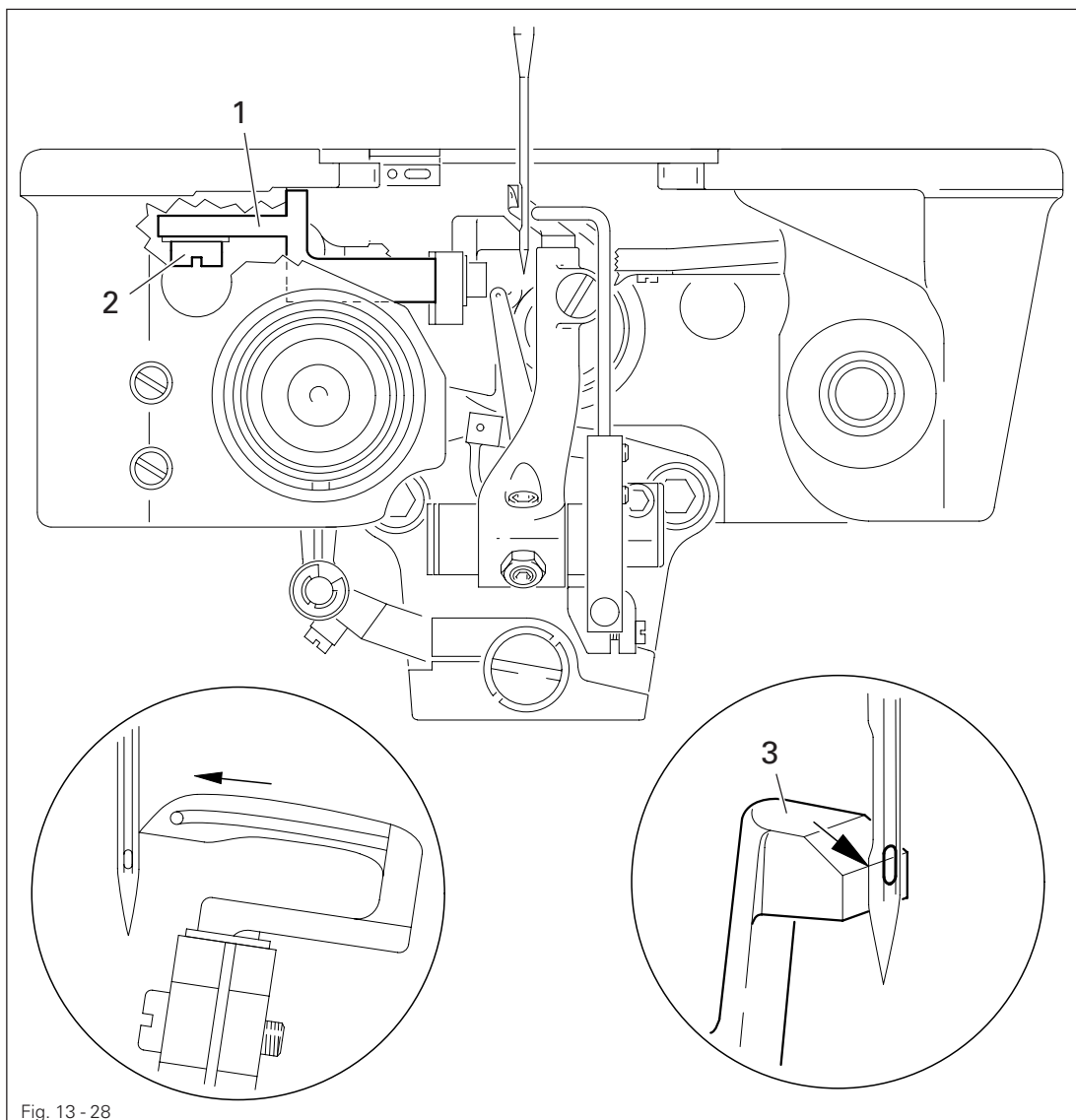
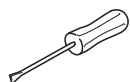

Fig. 13 - 28



- Turn the balance wheel until the looper point is located at the right side of the needle.
- Adjust bracket **1** (screw **2**) according to the **requirement**.



Under no circumstances should the needle be deflected by the needle guard **3**!

13.05.29 Position of the front needle guard (does not apply to all machines)

Requirement

When the point of the looper 1, which is advancing from the right, is positioned in the center of the needle, the needle guard clip 4 must

1. have a side clearance to the needle of **0.3 - 0.5 mm**
2. be parallel to the looper blade
3. have its top edge at the same height as the point of looper 1.

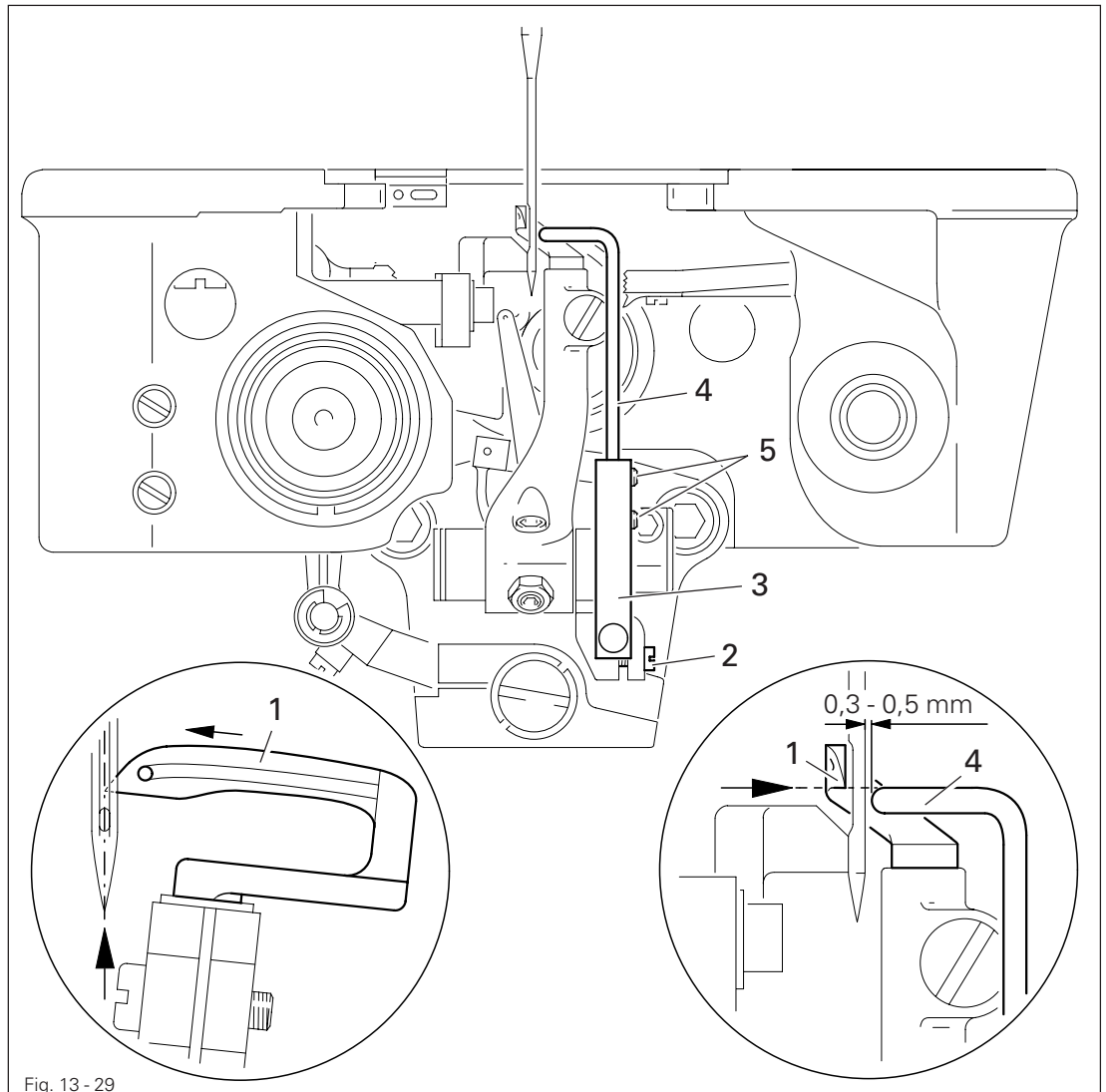
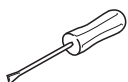

Fig. 13 - 29



- By turning the balance wheel bring looper 1 to its left point of reversal.
- Loosen screws 2.
- Adjust needle guard bracket 3 so that in this position the needle guard clip 4 is not in contact with looper 1.
- Slightly tighten screws 2.
- Turn the balance wheel until the point of the looper 1, when coming from the right, is positioned in the center of the needle.
- Adjust needle guard bracket 3 according to **requirement 1**.
- Align needle guard clip 4 (screws 5) according to **requirement 2 and 3**.

Adjustment

13.05.30 Guard of looper-avoiding-motion eccentric

Requirement

During motion the eccentric **3** must not touch guard **1**.

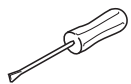
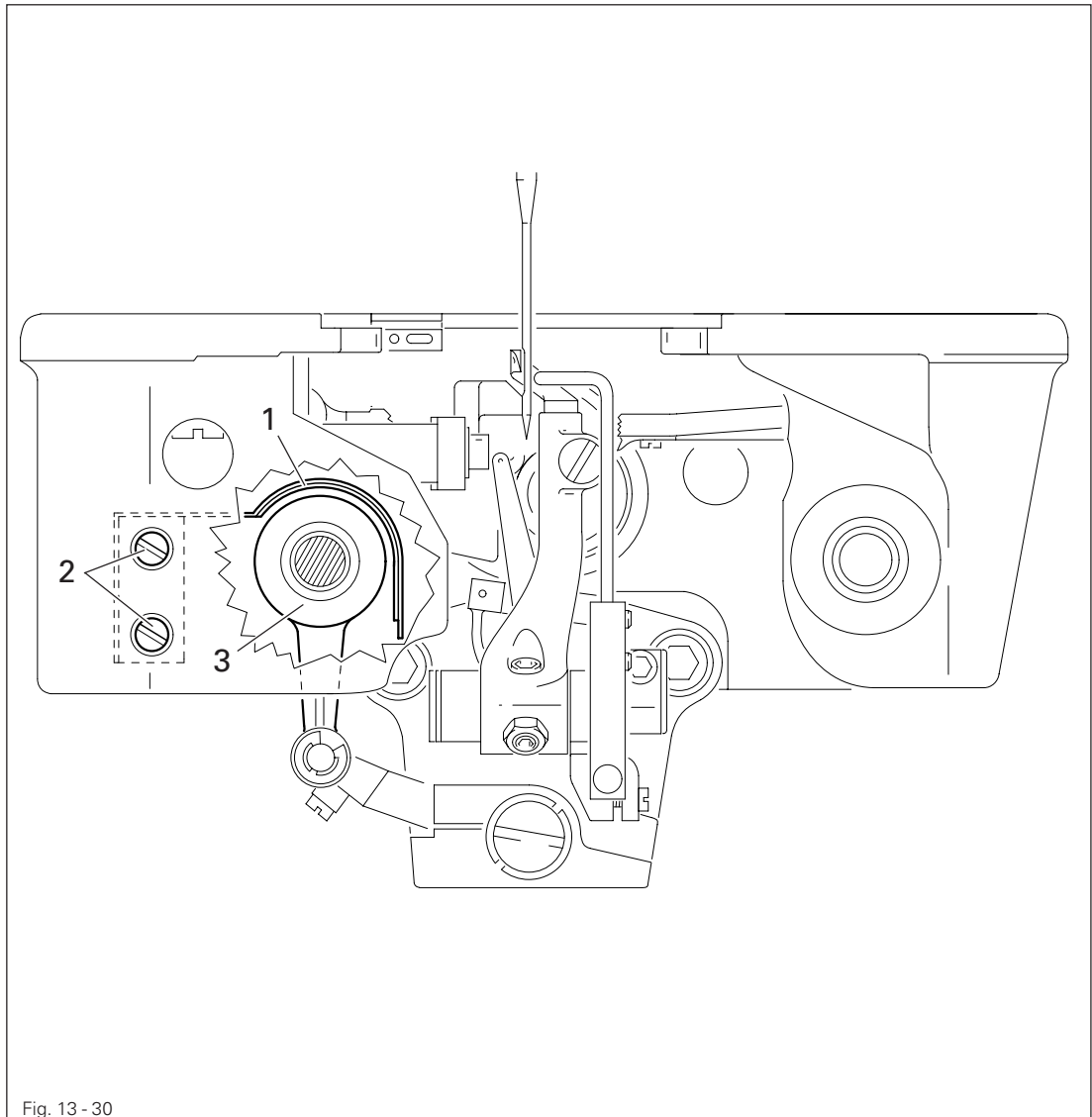

- Adjust guard **1** (screws **2**, accessible through adjustment holes) according to the requirement.

13.05.31 Take-up lever

Requirement

1. When the needle bar is at BDC (pin in hole 3) there must be a clearance of about **0.3 mm** between the take-up lever **2** and the needle bar frame **3**.
2. The take-up lever **2** must be able to move freely in the center of the needle head slot, and must not have any contact either at TDC or BDC.

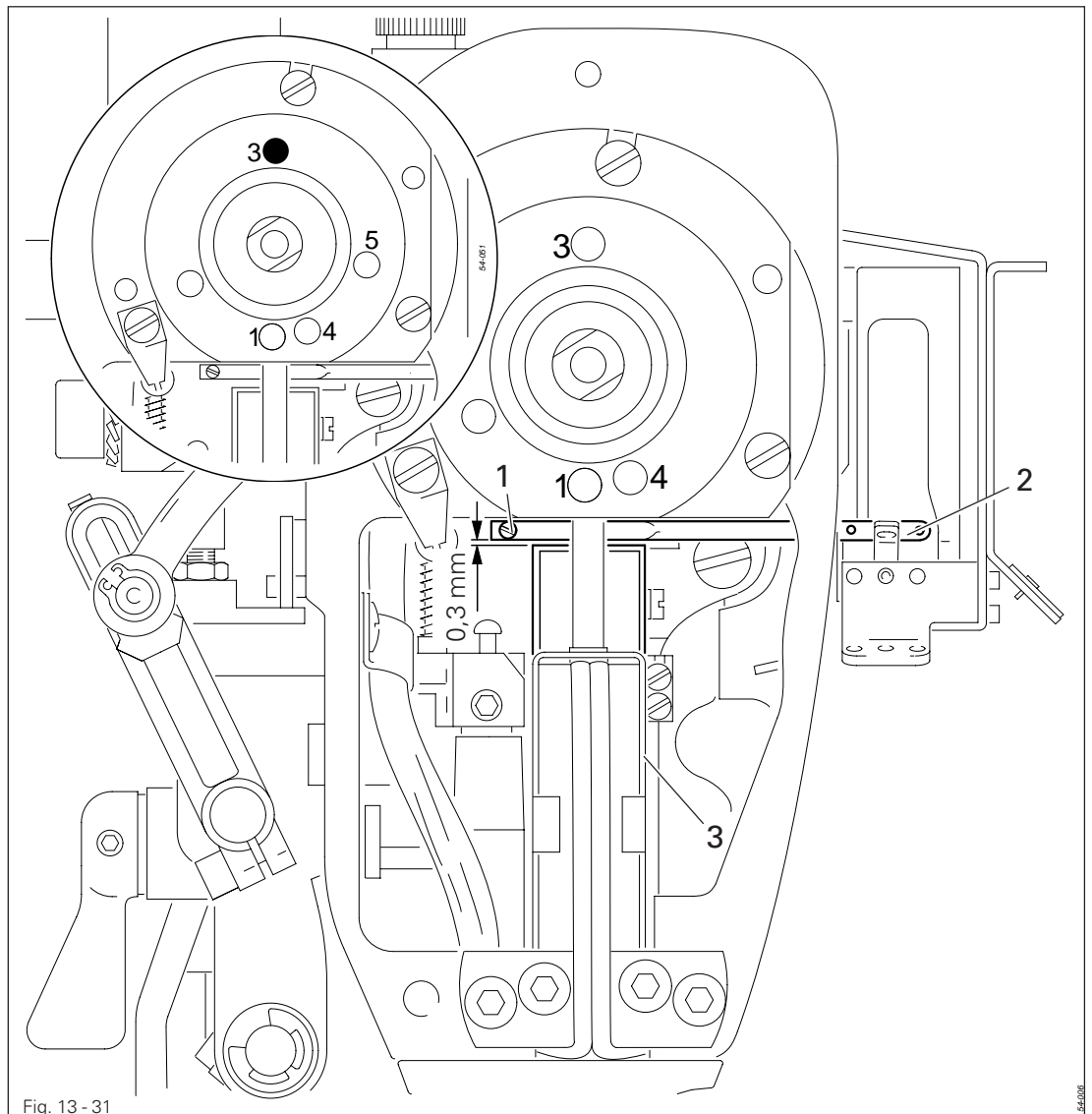
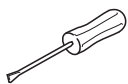

Fig. 13 - 31



- By turning the handwheel make screw **1** accessible and loosen it slightly.
- Bring needle bar to BDC.
- Adjust take-up lever **2** according to **requirement 1**.
- Tighten screw **1** in compliance with **requirement 2**.

13.05.32 Basic setting of the needle thread regulator and the thread guide

Requirement

1. With the needle bar at BDC (pin in hole 3) the eye of the needle thread regulator 1 and the adjustment hole of the take-up lever 4 must be in line.
2. The thread guide 2 must be vertical and attached with a screw in the center of the elongated hole.

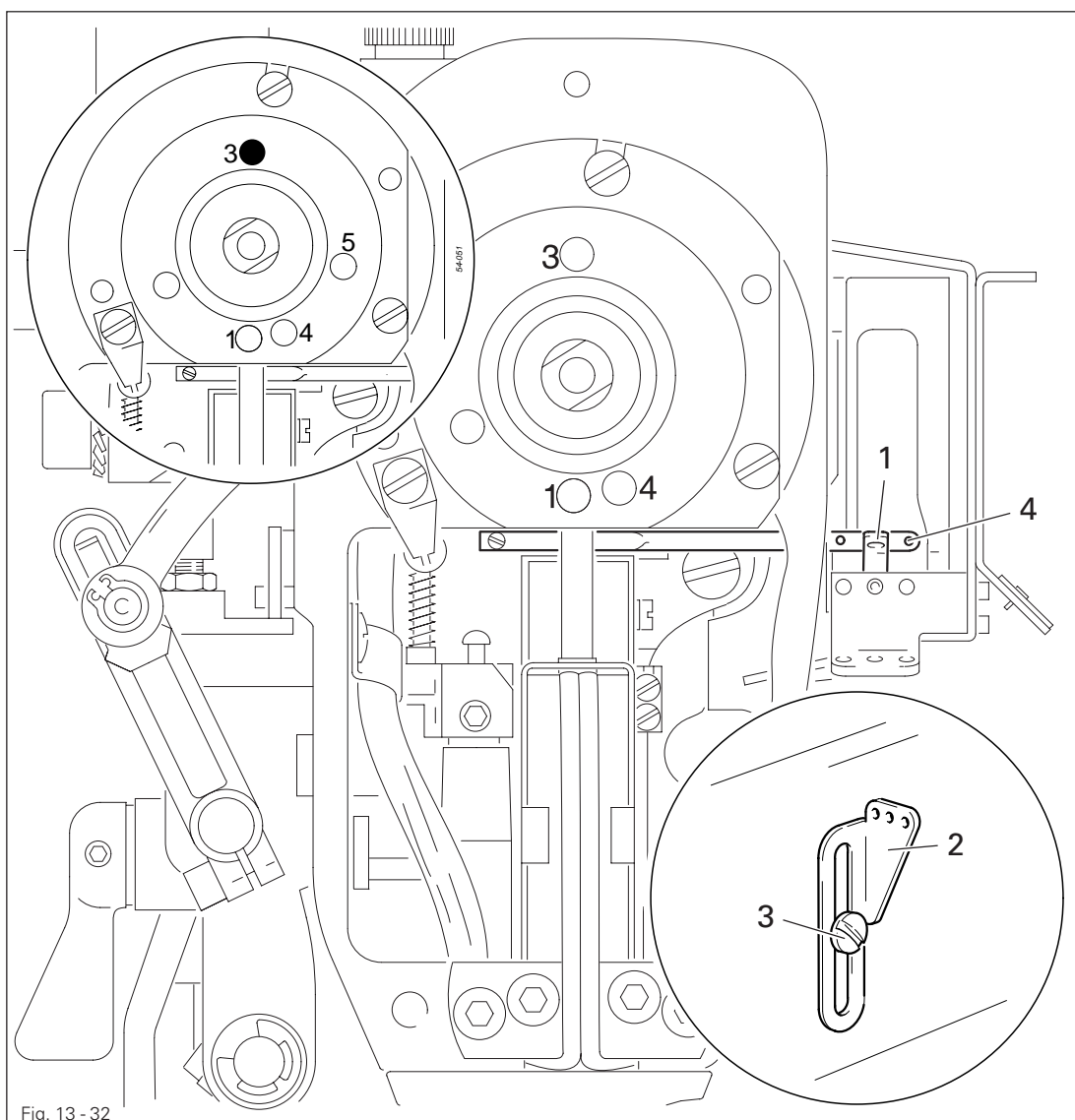
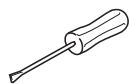

Fig. 13-32



- Bring the needle bar to bottom dead center.
- After loosening the screw, adjust the needle thread regulator 1 according to **requirement 1**.
- Tighten the screw of the needle thread regulator.
- Align thread guide 2 (screw 3) according to **requirement 2**.



Depending on the type of material and thread used, the basic setting may have to be modified.

13.05.33 Looper thread regulator and looper thread take-up

Requirement

1. The distance between the front edge of looper thread regulator **1** and the rear needle plate edge guide must be **29 mm**.
2. The front edges of the thread take-up device **3** and the thread regulator **1** must be about **8 mm** apart.

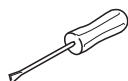
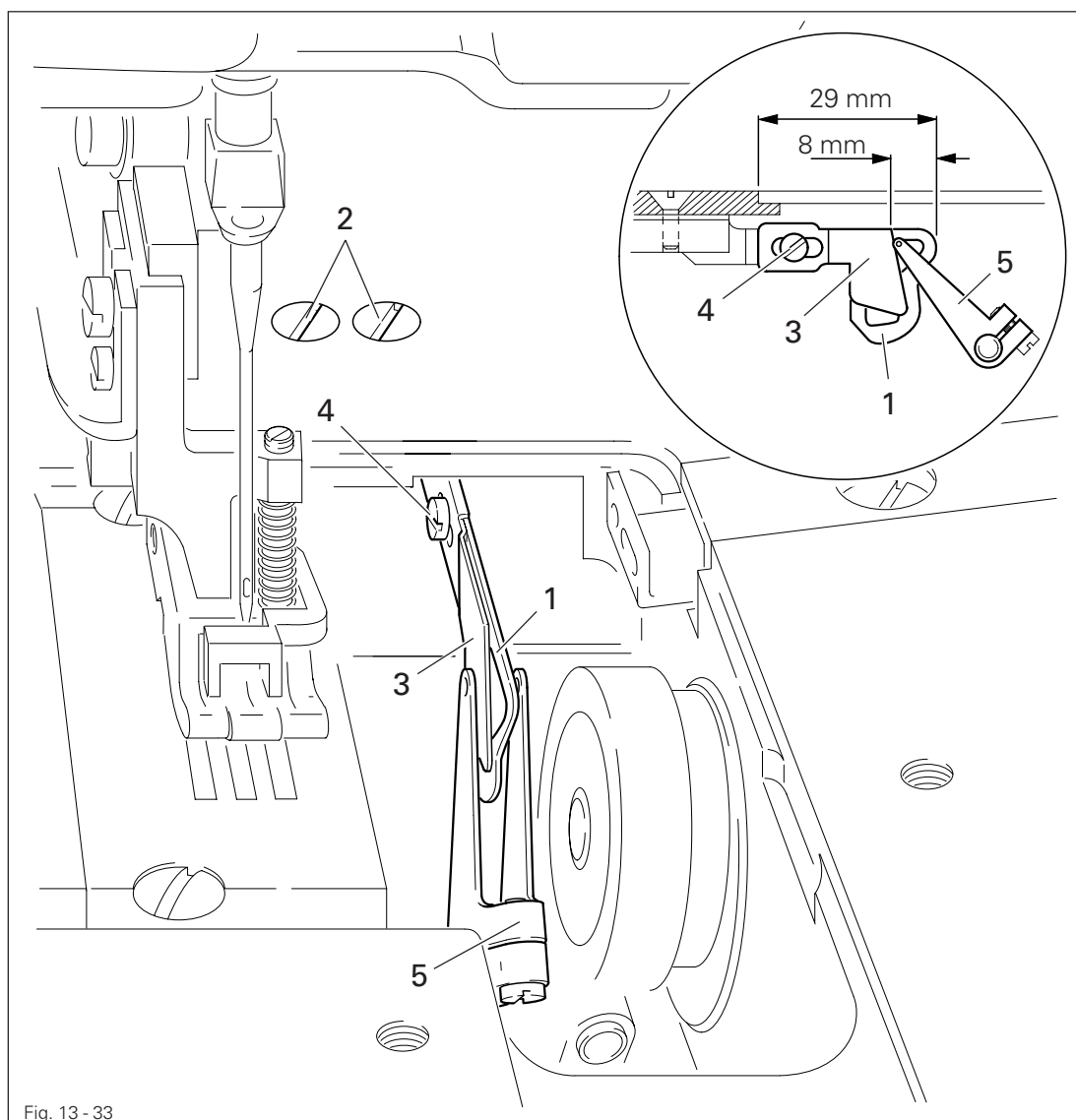

- Adjust thread regulator **1** (screws **2**) according to **requirement 1**.
- Adjust thread take-up device **3** (screw **4**) according to **requirement 2**.



Depending on the type of material and thread used, the basic setting may have to be modified.

13.05.34 Looper thread puller

Requirement

With the needle bar in top dead center (pin in hole 1) both eyes of looper thread puller 1 must be at the front edge of the thread take-up device 4.

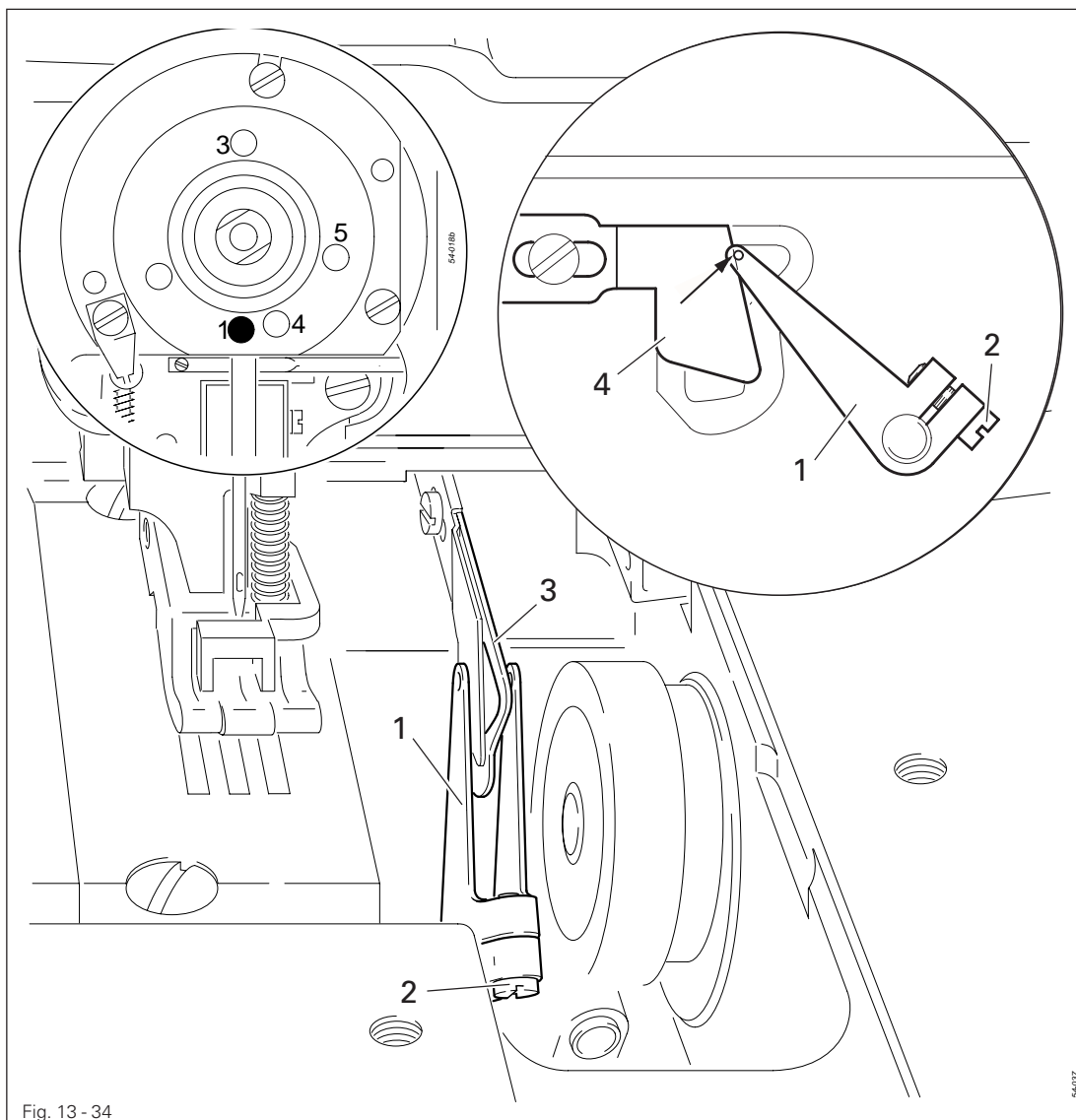
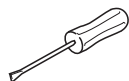

Fig. 13 - 34



- Bring needle bar to top dead center.
- Turn thread puller 1 (screw 2) according to the **requirement**, making sure that the prongs of thread puller 1 are in the middle of the thread regulator 3.



Depending on the type of material and thread used, the basic setting may have to be modified.

13.05.35 Top feed dog and sewing foot pressure

Requirement

The pressure of the top feed dog and the sewing foot should be set, so that the best possible feeding of the workpiece is achieved at every speed.

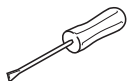
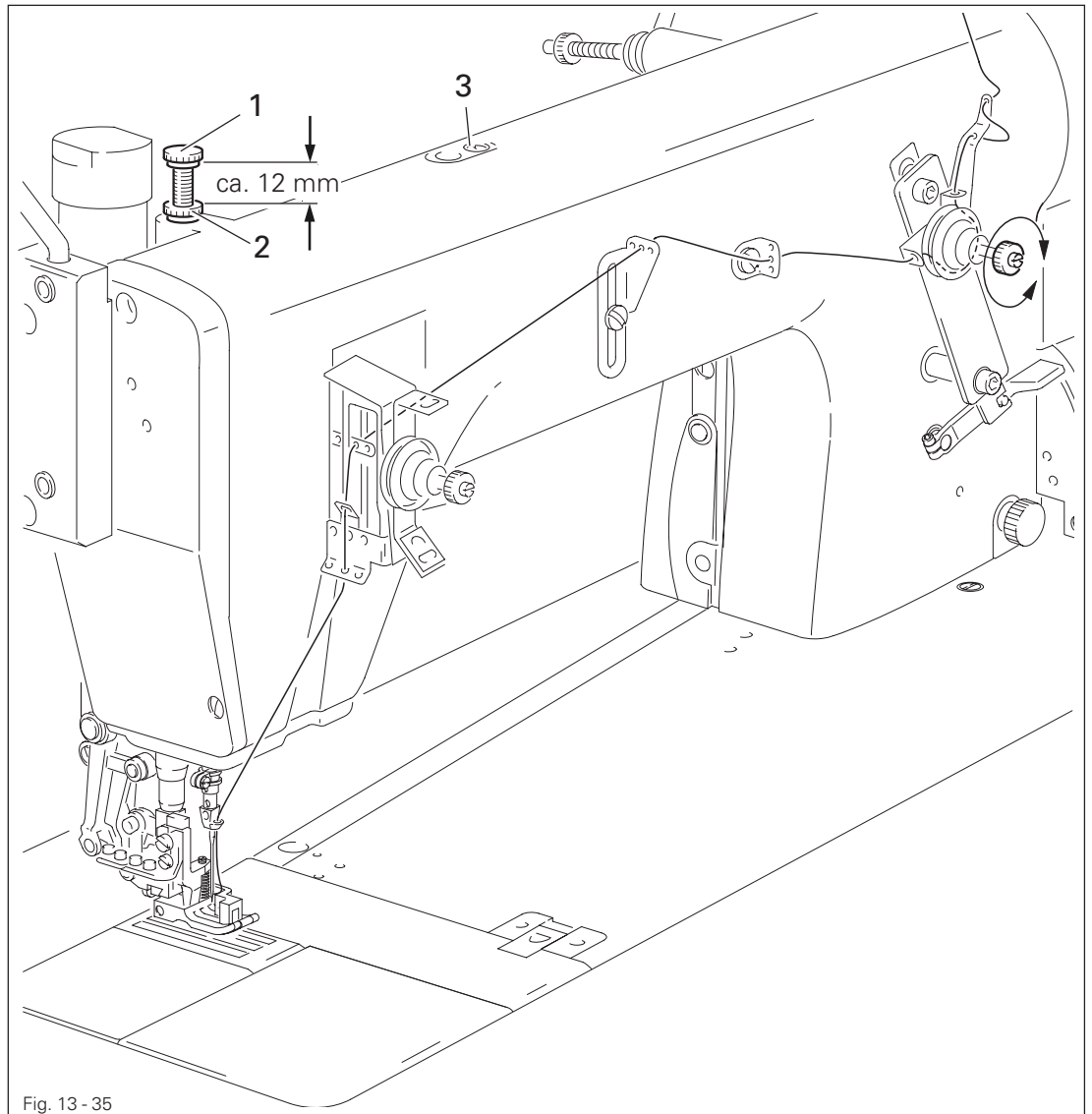

- Adjust sewing foot pressure with screw 1 (nut 2) according to the requirement.
- With screw 3 adjust the pressure of the top feed dog according to the requirement.

Adjustment

13.06 Adjusting the edge trimming mechanism

13.06.01 Knife stroke

Requirement

When the needle bar is at t.d.c., the knife should be at the top of its stroke.

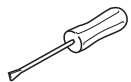
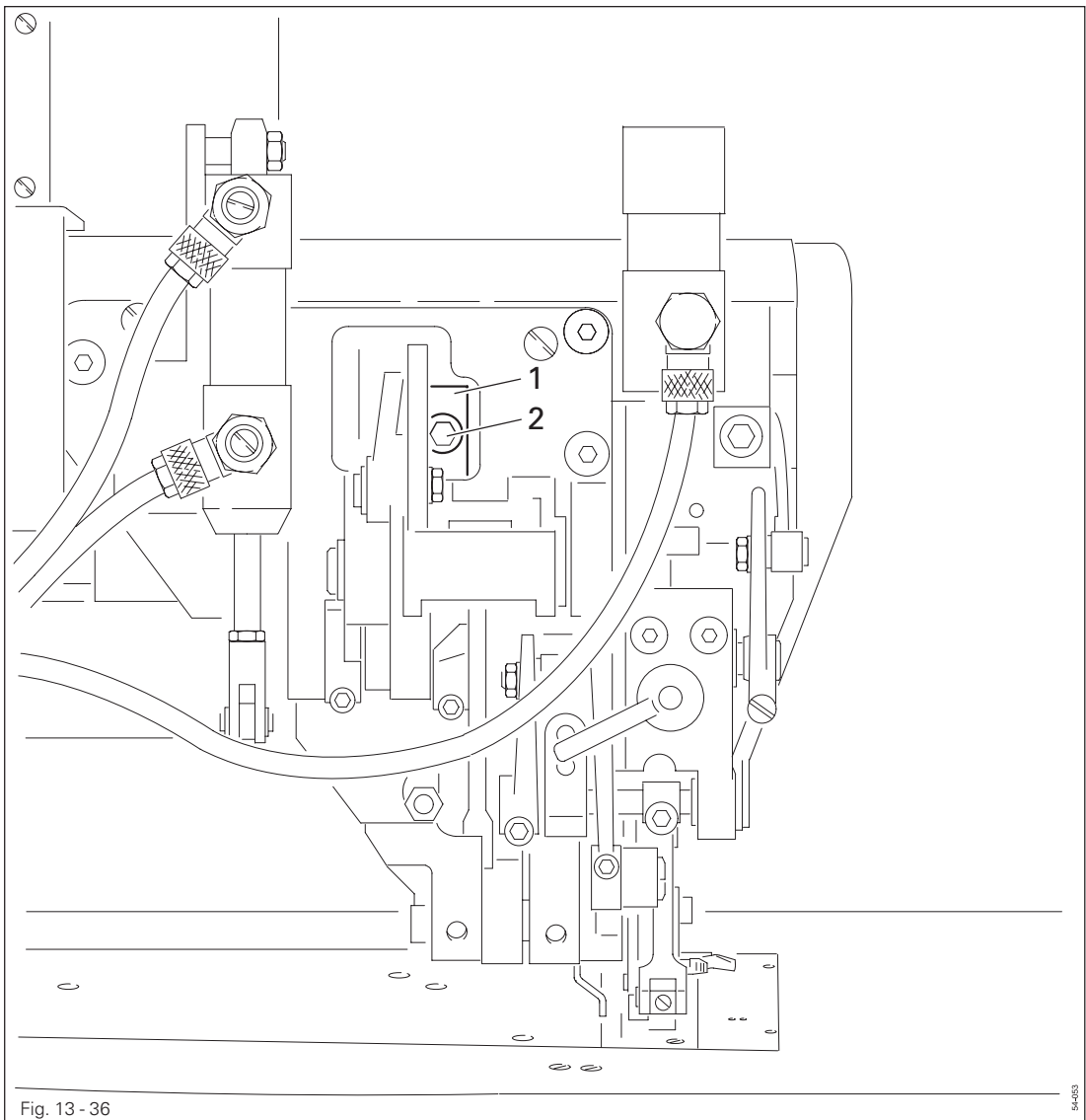

- Adjust eccentric 1 (screw 2) according to the requirement.

13.06.02 Neutral position

Requirement

When cylinder 3 is fully extended, the knife should not move when the balance wheel is turned.

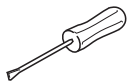
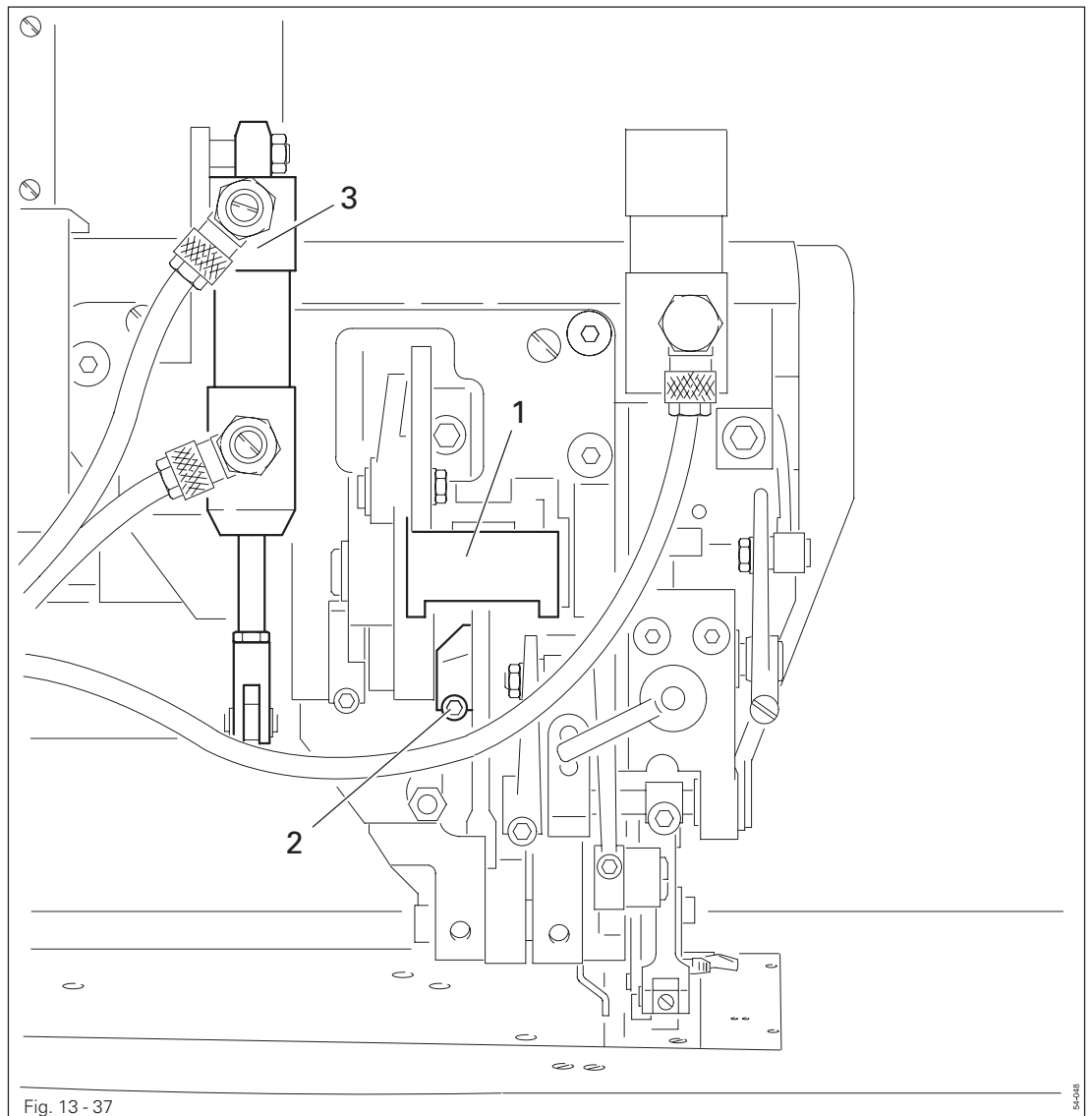

- Turn crank 1 (screws 2) according to the **requirement**.

Adjustment

13.06.03 Starting position of the cylinder

Requirement

When cylinder 3 is retracted, nut 4 should be 10 mm from the bottom edge of cylinder 3.

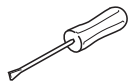
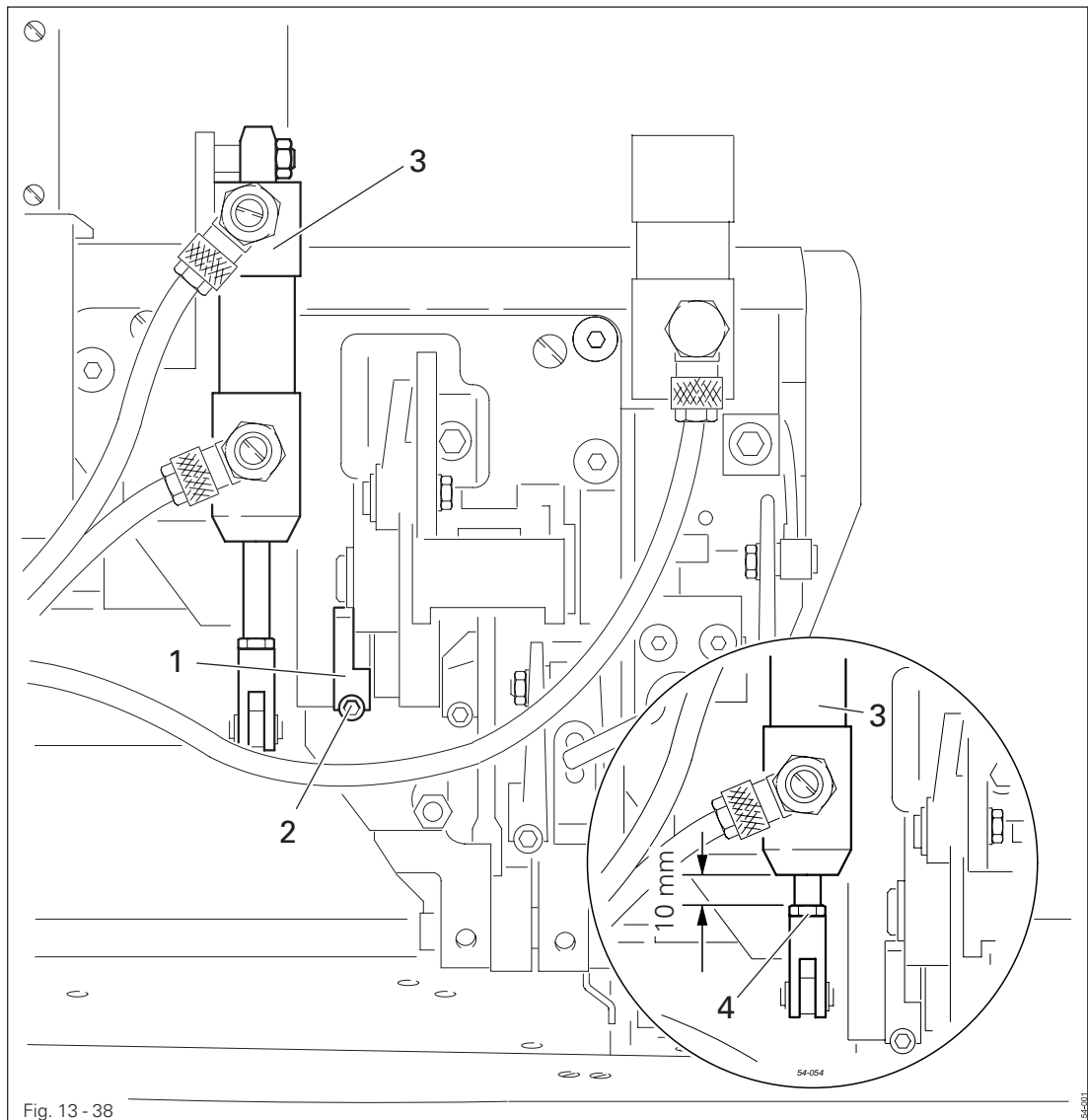

- Adjust stop 1 (screw 2) according to the **requirement**.

13.06.04 Knife height

Requirement

When the knife 1 is at b.d.c., the front edge of knife 1 should be approx. 0.5 mm below the top edge of the needle plate.

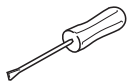
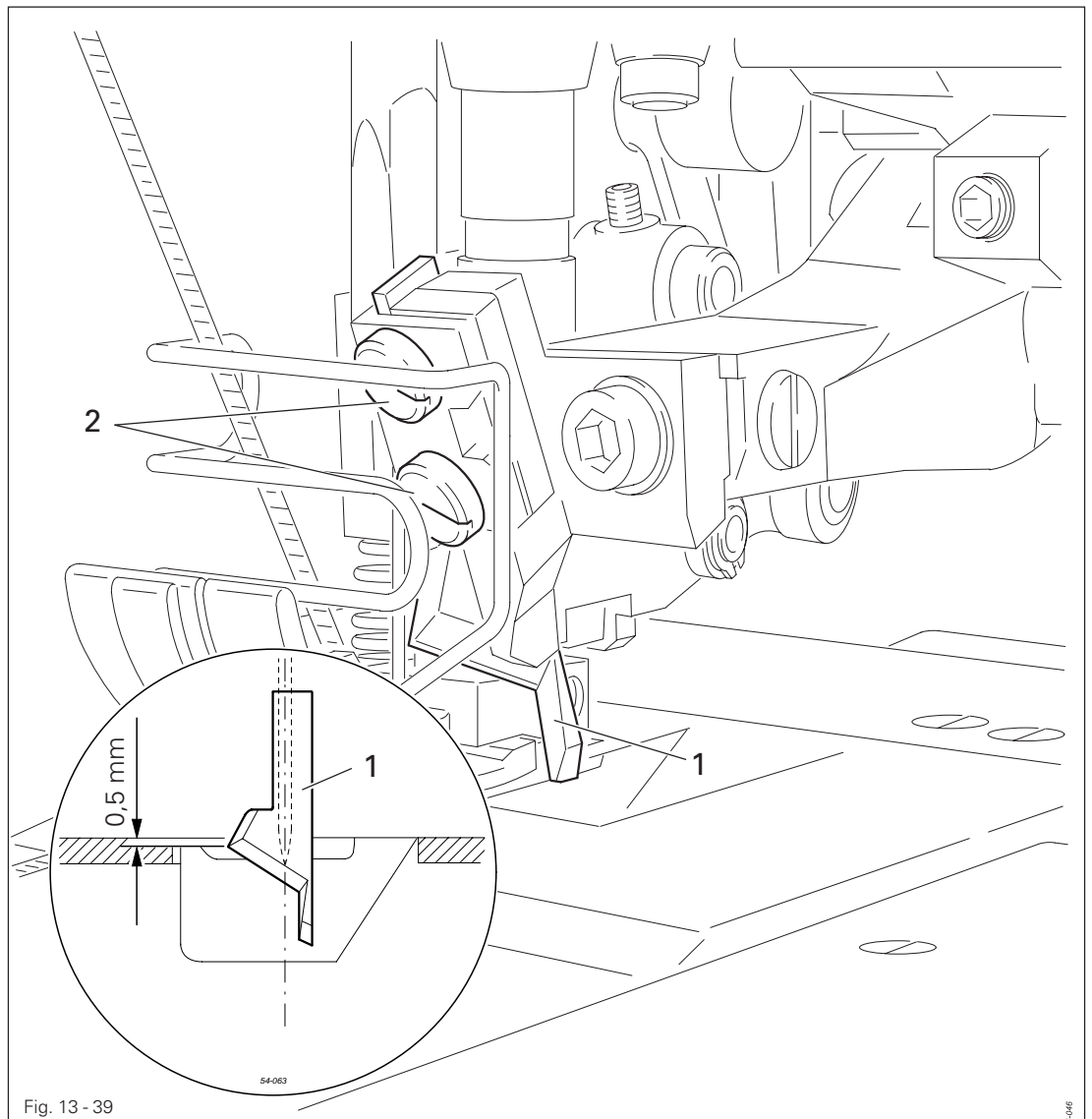

- Adjust knife 1 (screw 2) according to the requirement.

Adjustment

13.06.05 Knife position crosswise to sewing direction

Requirement

1. The knife **3** must rest with light pressure against the stationary knife.
2. The knife **3** should, however, not strike the needle plate.

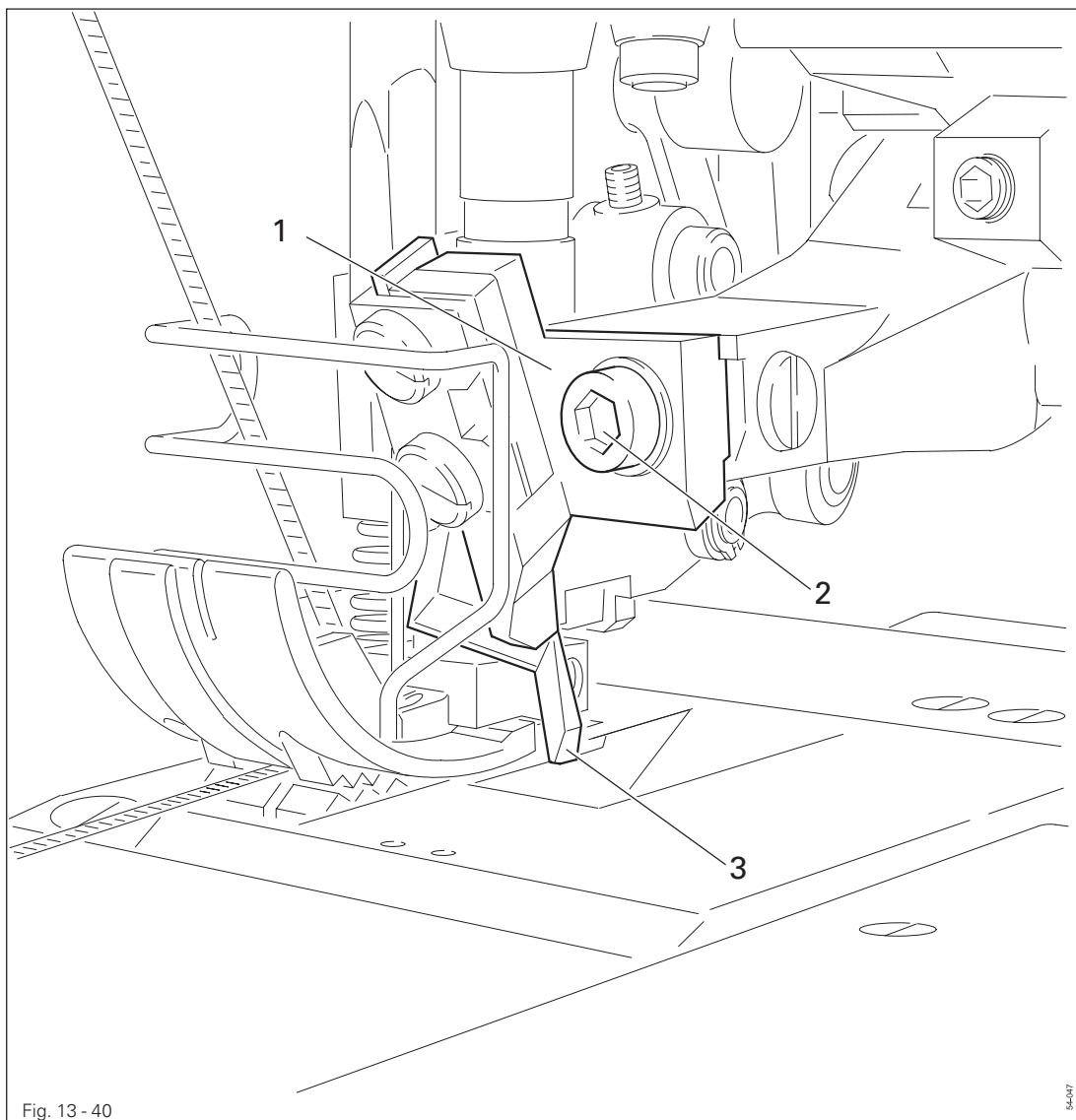

Fig. 13 - 40

54-017



- Bring the knife into its lowest position and adjust knife mounting **1** (screw **2**) according to the requirements.

13.07 Parameter settings

13.07.01 Overview of the parameter functions

After the machine has been switched on, by pressing the appropriate function the input mode is called up, in which the individual parameters can be called up directly. With a code it is possible to protect all or individual parameter groups against unauthorised access.

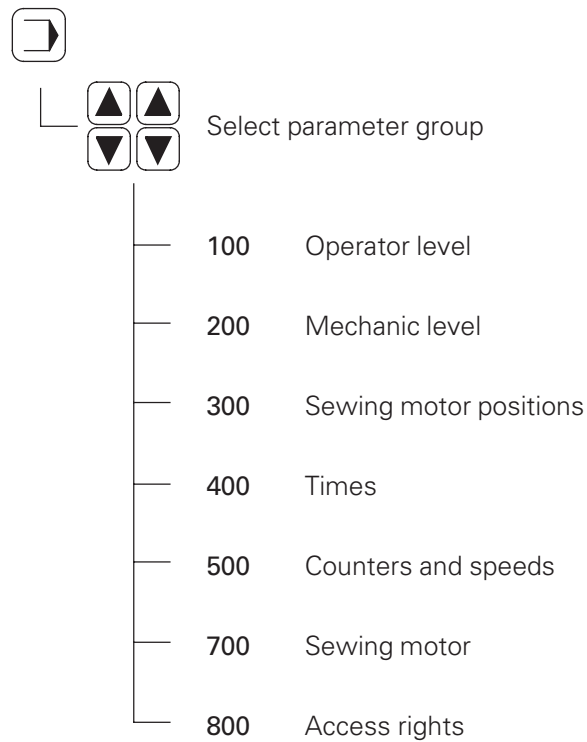



Adjustment

13.07.02 Example of a parameter input

- Switch on the machine.

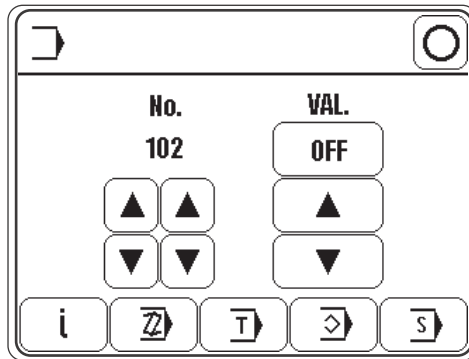
-  ● Call up the input mode.



-  ● e.g. call up parameter "113" (switch beep tone for section change on/off)

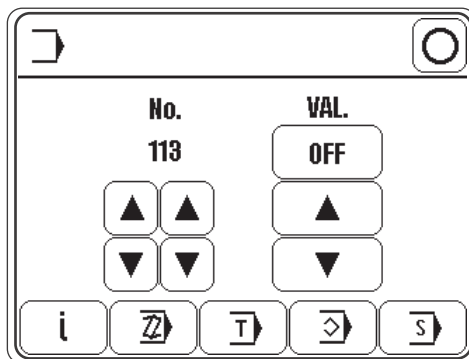

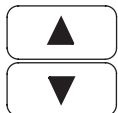
-  ● e.g. switch beep tone on (value "ON").

-  ● Conclude the input.

13.07.03 List of parameters



The operator has free access to the "100" parameters. Parameters "200" - "800" can only be changed after entering a code number and may only be changed by authorised personnel.

Group	Parameter	Description	Setting range	Set value
1	102	Reversing	OFF - ON	OFF
	113	Beep tone for section change	OFF - ON	OFF
	114	Max. speed forwards at each pedal position	OFF - ON	OFF
2	201	Machine configuration 3 = 3811-3/55 4 = 3811-15/... 5 = 3811-16/...	3 - 5	-
	209	Fullness adjustment value (keyboard)	0 - 9	0
	210	Switch off edge knife (with pedal position "-2")	OFF - ON	OFF
3	301	Position "Needle point at top edge needle plate"	0 - 127	0
	302	Position "take-up lever t.d.c."	0 - 127	107
	303	Position "needle lowered"	0 - 127	60
	304	Reversing position	0 - 127	107
	305	Placement stitch position	0 - 127	7
4	401	Delay time "lift foot" (s)	0,01 - 1,50	0.02
	402	Start delay after "lower foot" (s)	0,01 - 1,50	0.15
	403	Thread trimming time (s)	0,01 - 0,20	0.12
	404	Time for cleaning thread monitor (s)	0,01 - 1,50	0.25
5	501	Maximum speed	100 - 4200	4200
	504	Speed soft start	100 - 3500	1500
	505	Soft start stitches	0 - 15	0
7	701	P-quota speed controller	1 - 50	12
	702	I-quota speed controller	0 - 100	50
	703	P-quota position controller	1 - 50	20
	704	D-quota position controller	1 - 100	30

Adjustment

Group	Parameter	Description	Setting range	Set value
7	705	Time for position controller	0 - 100	25
	706	P-quota position controller for rest brake	1 - 50	25
	707	D-quota position controller for rest brake	1 - 50	15
	708	Maximum moment for rest brake	0 - 100	0
	709	Minimum machine speed	3 - 64	6
	710	Maximum machine speed	1 - 42	42
	711	Maximum motor speed	1 - 42	42
	712	Positioning speed	3 - 25	18
	713	Acceleration ramp	1 - 50	35
	714	Brake ramp	1 - 50	30
	715	Reference position	0 - 127	0
	716	Time-out	0 - 255	40
	717	Starting current motor	3 - 10	8
	718	Anti-vibration filter	1 - 10	6
	719	Rotation direction allocation	0 - 1	0
720	Reference position correction	0 - 127	64	
8	801	Right of access function group 100	0 - 1	0
	802	Right of access function group 200	0 - 1	1
	803	Right of access function group 300	0 - 1	1
	804	Right of access function group 400	0 - 1	1
	805	Right of access function group 500	0 - 1	1
	806	Right of access service	0 - 1	1
	807	Right of access function group 700	0 - 1	1
	808	Right of access function group 800	0 - 1	1
	809	Right of access program creation	0 - 1	1
	810	Enter access code	0 - 9999	3800

13.08 Sewing motor errors

Error message	Description
34	Brake path too short
35	Communication error with limit control
36	Switch on sequence not ready
65	Extint low with Init
66	Short circuit
68	Extint low in operation
69	No increments
70	Motor stalling
71	No incremental plug
73	Disturbed motor running
75	Regulator blocked
170	Invalid transmission
171	Invalid zero point
175	Starting error
222	Time-out monitoring

13.09 Explanation of the error messages

Message	Description
E001	System error
E002	Sewing motor E002/BB/xxx BB = 20: Time-out 02: Position forwards 03: Position in reverse 05: Position by shortest path 09: Write parameter 10: Speed 0A: Reset stitch counter 0B: Stop after xxx stitches 30: Time-out for increasing speed 31: Time-out for uncertain positioning 32: Time-out for time-out command 33: Time-out for deleting errors 34: Time-out for emergency stop 35: Time-out for writing parameters 36: Time-out for resetting stitch counter 37: Time-out for stop command after x stitches 38: Time-out for initialization xxx = error bytes of sewing motor control unit (see Chapter 13.08 Sewing Motor Errors)
E003	Section
E004	End of section
E005	Pedal activated when machine switched on
E007	End of ramp
E008	Reference for fullness adjustment not found 1: When moving towards sensor 2: When moving away from sensor
E011	Stepping motor stepping frequency too high
E014	Incorrect program number (larger than 49)
E015	Incorrect seam section number
E016	Memory full
E021	Power supply unit overloaded
E022	Mains voltage
E023	Power supply 24V too low
E024	Error at CAN interface

13.10 Table of inputs

E1	not assigned
E2	not assigned
E3	not assigned
E4	Start inhibitor
E5	not assigned
E6	Knee switch
E7	not assigned
E8	not assigned
E9	not assigned
E10	not assigned
E11	not assigned
E12	not assigned
E13	not assigned
E14	not assigned
E15	not assigned
E16	Reference for fullness adjustment

13.11 Table of outputs

O1	Raise sewing foot (O1.1 and O1.2)
O2	Thread trimmer (O2.1 and O2.2)
O3	Tape brake
O4	Stitch length 4 mm / 3 mm
O5	not assigned
O6	Condensed stitches
O7	Edge trimmer
O8	not assigned
O9	not assigned
O10	not assigned
O11	not assigned
O12	not assigned
O13	not assigned
O14	not assigned
O15	not assigned
O16	not assigned

13.12 Service menu

In the service menu information is displayed about the machine's inputs and outputs, as well as the values for the pedal and the balance wheel position.

In addition the following functions can also be carried out.

- Switch on the machine.



- Call up the input mode.



- Call up the service menu.

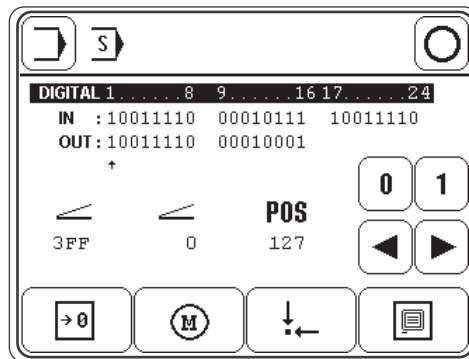

Explanation of the functions



Input mode

Quit the service menu and call up the input mode.



Sewing mode

Quit the service menu and call up the sewing mode.



Set/reset outputs

Use the arrow functions to select the desired output and set "function 1" or reset "function 2".

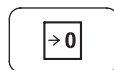

Cold start

See Chapter 13.13 Carry out a cold start.



Motors

After this function has been called up, the stepping motors for fullness and for the sewing motor can be moved.

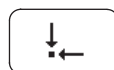

Basic position of the stepping motor

After this function has been called up, the basic position of the fullness stepping motor can be changed.



Control panel

See Chapter 9.07 Adjusting the control panel.

13.13 Carry out a cold start

- Switch on the machine.



- Call up the input mode.

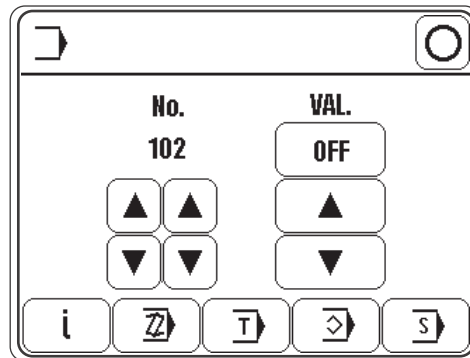

- Call up the service menu.

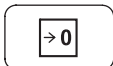
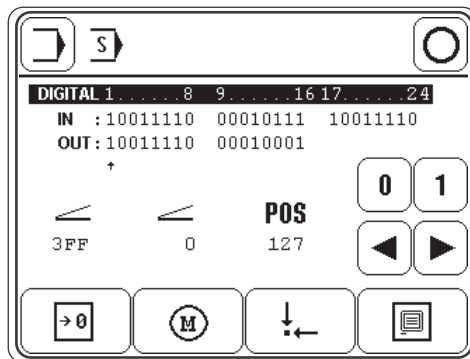

- Carry out a cold start.



After a cold start all programmed values are set back to their status at the time of delivery.

All sewing programs are also deleted.

13.14 Internet update of the machine software

The machine software can be updated with PFAFF flash programming. For this purpose the PFP boot program and the appropriate control software for the machine type must be installed on a PC. To transfer the data to the machine, the PC and the machine control unit must be connected with an appropriate null modem cable (part no. 91-291 998-91).



The PFP boot program and the control software of the machine type can be downloaded from the PFAFF-homepage using the following path:
www.pfaff-industrial.de/pfaff/de/service/downloads

To update the machine software carry out the following steps:



While the machine software is being updated, no setting up, maintenance or adjustment work may be carried out on the machine!

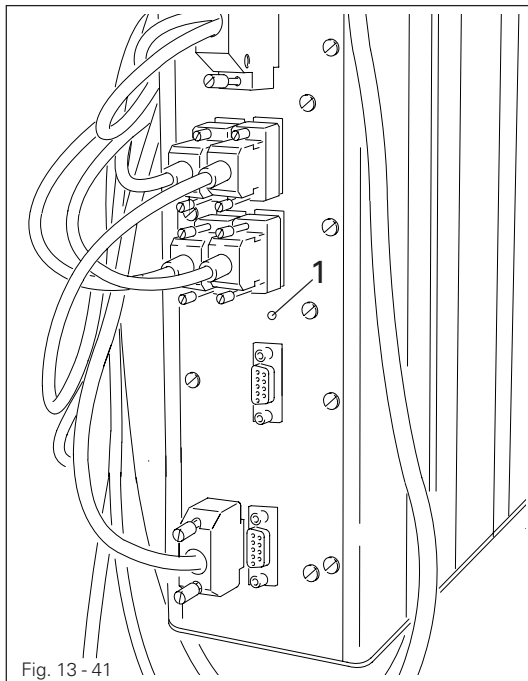

Fig. 13 - 41

- Switch off the machine.
- Connect the PC (serial interface or appropriate USB-adapter) and the machine control unit (RS232). To do so disconnect the plug of the control panel.
- Switch on the PC and start the PFP boot program.
- Select the machine type.
- Press the "programming" button.
- Hold down boot key 1 and switch on the machine.
- Press the "OK" button.

- The software update is carried out, the update progress is shown on the bar display of the PFP boot program.
- During the up-dating procedure the machine must not be switched off.
- When the update has been completed, switch off the machine and end the PFP boot program.
- End the connection between the PC and the machine control unit and reconnect the control panel to the machine control unit.
- Switch on the machine.

A plausibility control is carried out and, if necessary, a cold start.



More information and assistance is at your disposal in the file "PFPHILFE.TXT", which can be called up from the PFP boot program by pressing the "help" button.

Wearing parts



This is a list of the most important wearing parts.

A detailed parts list for the complete machine is included with the accessories.

In case of loss, the parts list can be downloaded from the internet address

www.pfaff-industrial.com/pfaff/en/service/downloads.

As an alternative to the internet download the parts lists can also be ordered in book form under part no. 296-12-18 591.

PFAFF 3811-16/65

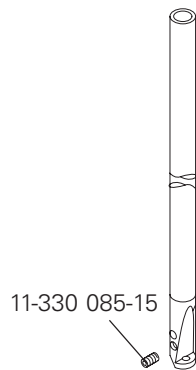

PFAFF 3811-3/55; -15/65

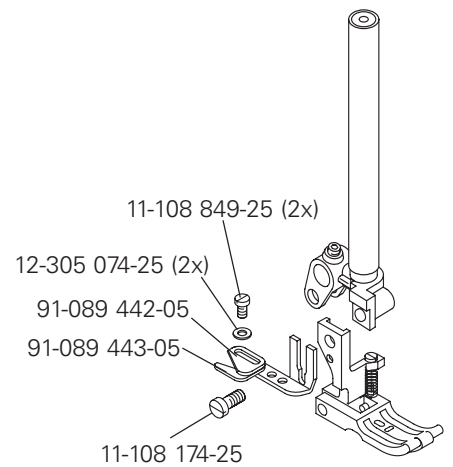

91-100 296-25 (2x)

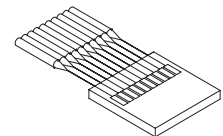
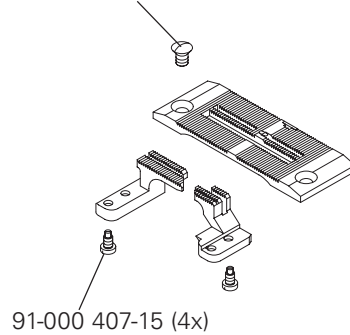

PFAFF 3811-15/65; -16/65
System 4463 -35
PFAFF 3811-3/55
System 4463-KKD

PFAFF 3811-3/55



PFAFF 3811-15/65; -16/65



PFAFF 3811-16/65

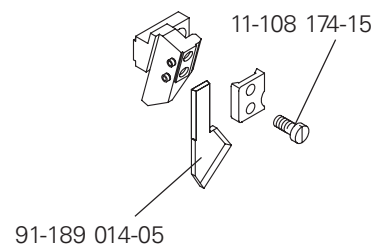

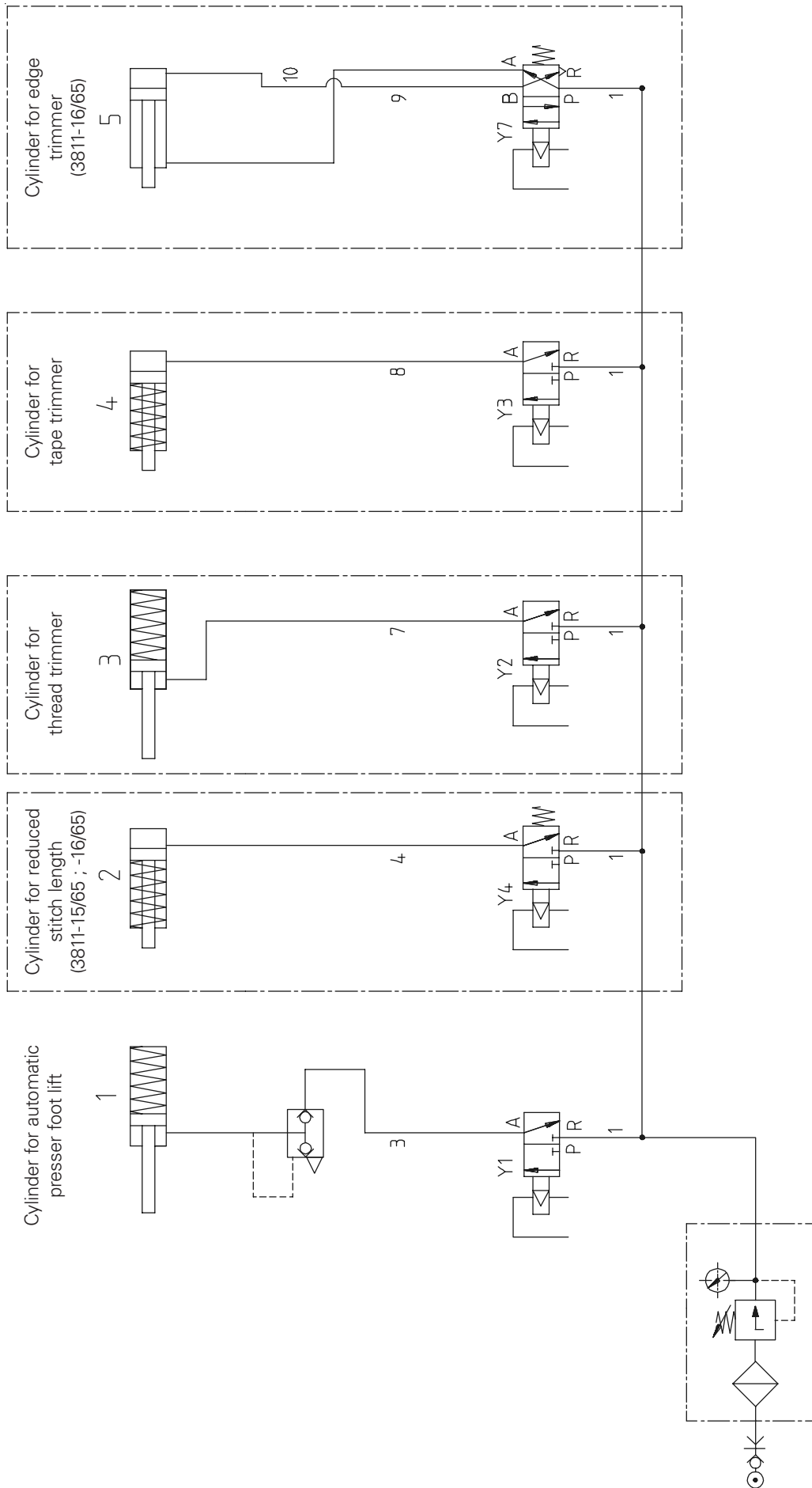

15 Circuit diagrams**Reference list for circuit diagrams**

A1	Controller Quick P 320MS
A2	Control panel T1
A3	Keyboard
A14	Sewing head identification (OTE)
B16	Initiator SM1, reference
H1	Sewing lamp
M1	Sewing motor
M3	Stepping motor fullness adjustment (SM1)
Q1	Main switch
S6	Knee switch (program switching)
S17	Pedal speed control unit
S18	Synchronizer PD3
X1	Mains plug
X1A	RS232 – interface 1 Control panel T1
X1B	VSS Sewing head identification (OTE)
X3	Incremental transmitter (control unit)
XR3	Incremental transmitter (sewing motor)
XS3	Synchronizer PD3
X4B	Stepping motor fullness (SM1)
X5	Inputs
X8	Sewing motor
X11A	CAN interface (Keyboard)
X11B	Pedal speed control unit
X13	Outputs
X21	Stepping motor fullness (SM1)
X22	Keyboard
X36	Knee switch (program switch)
X46	Initiator reference (SM1)
X51	Y1 910/.. Automatic presser foot lift
X52	Y2 900/.. Thread trimmer (option)
X53	Y3 Tape brake (option)
X54	Y4 Stitch length 3 + 4 mm (only on the PFAFF 3811-15/65, -16/65)
X57	Y7 Edge trimming mechanism (only on the PFAFF 3811-16/65)
Y1	910/.. Automatic presser foot lift
Y2	900/.. Thread trimmer (Option)
Y3	Tape brake (option)
Y4	Stitch length 3 + 4 mm (only on the PFAFF 3811-15/65, -16/65)
Y7	Edge trimming mechanism (only on the PFAFF 3811-16/65)

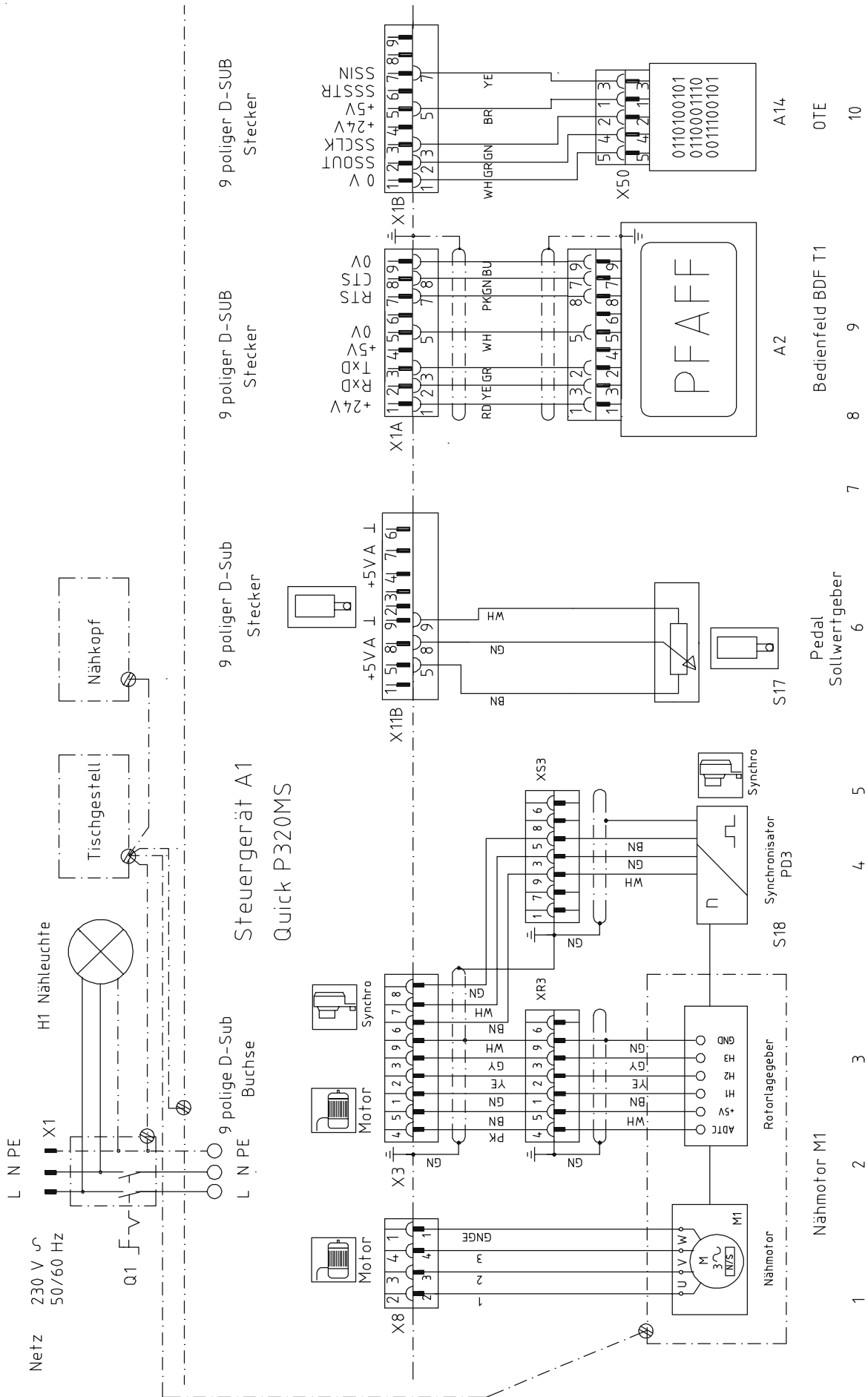

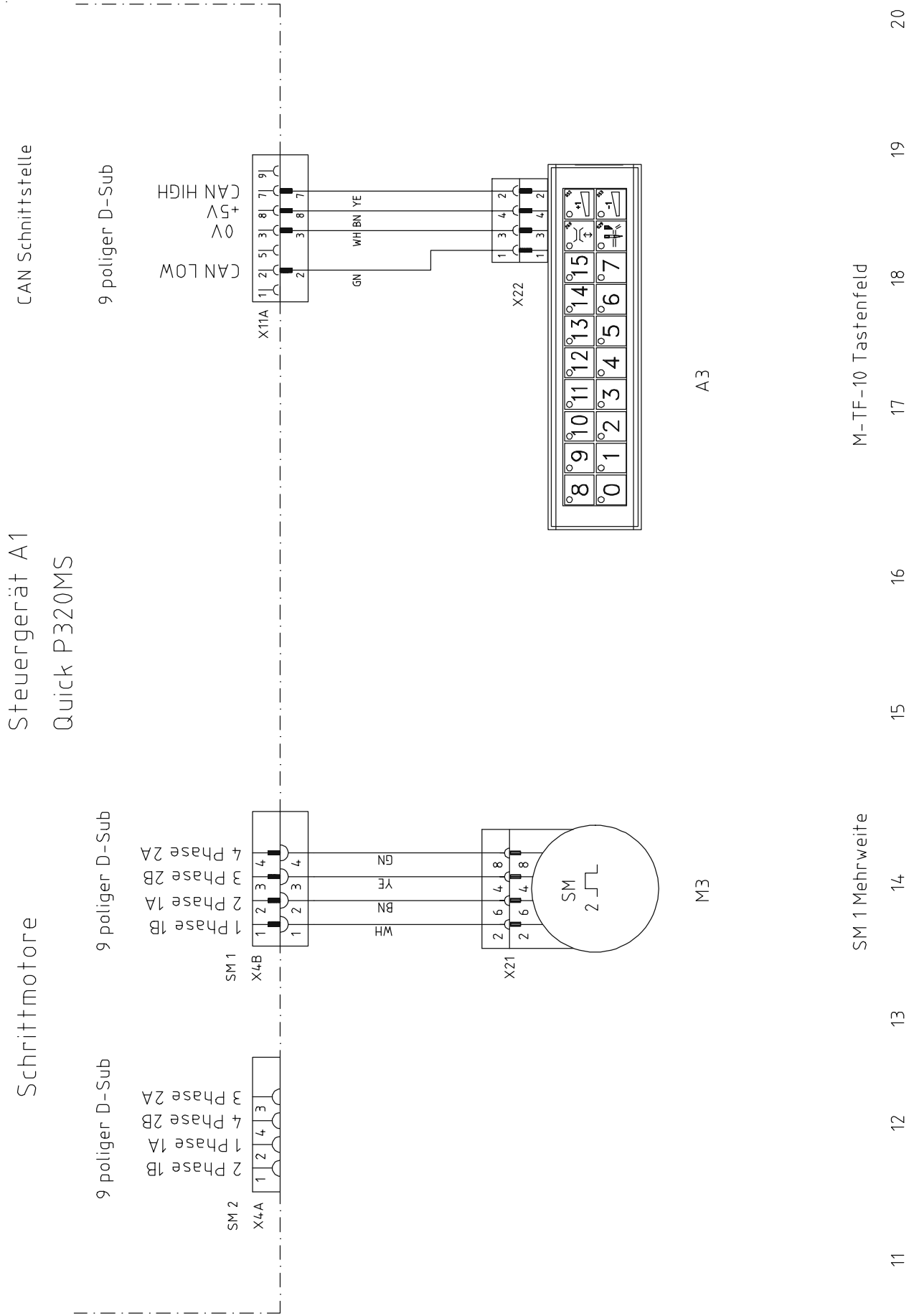

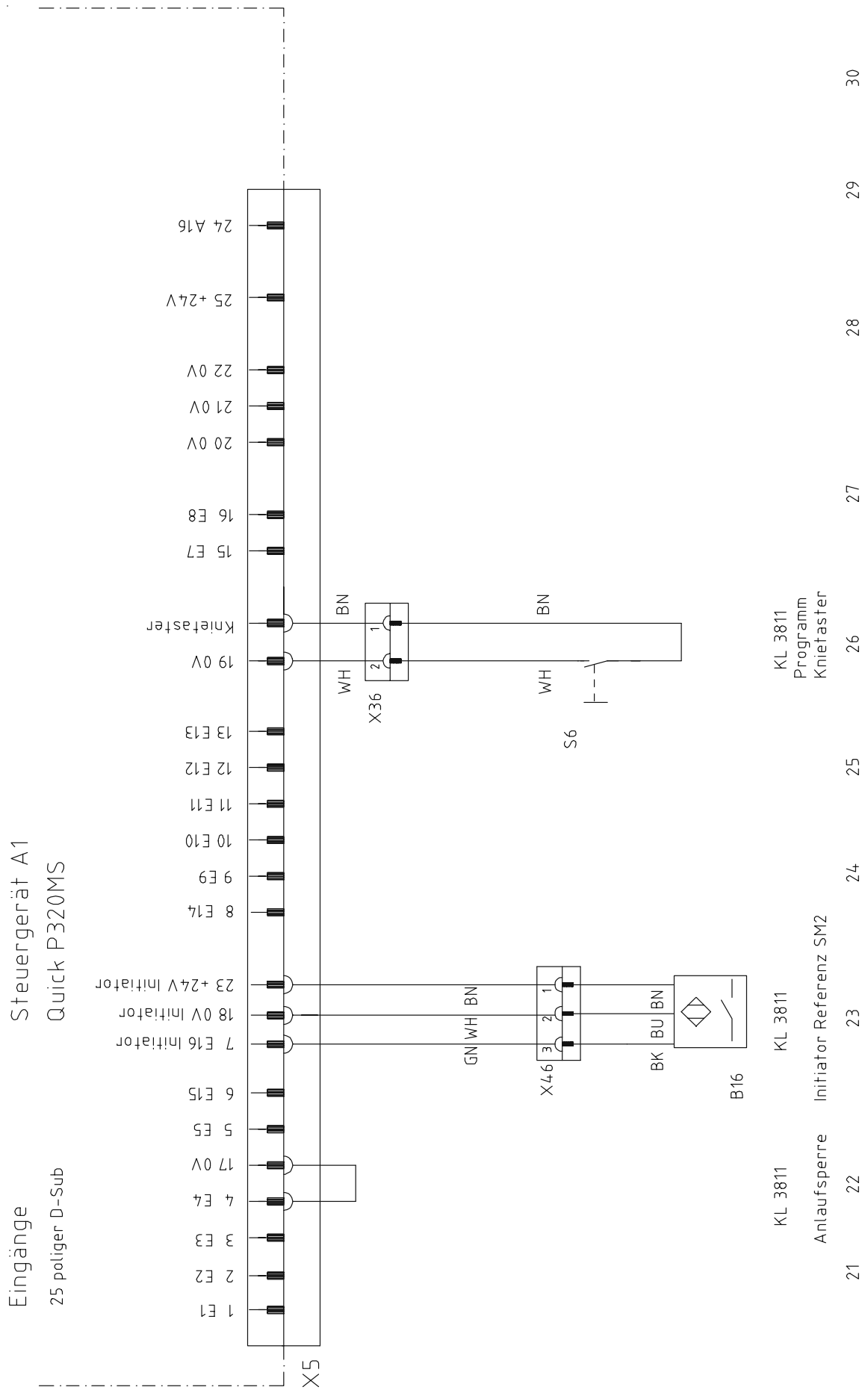

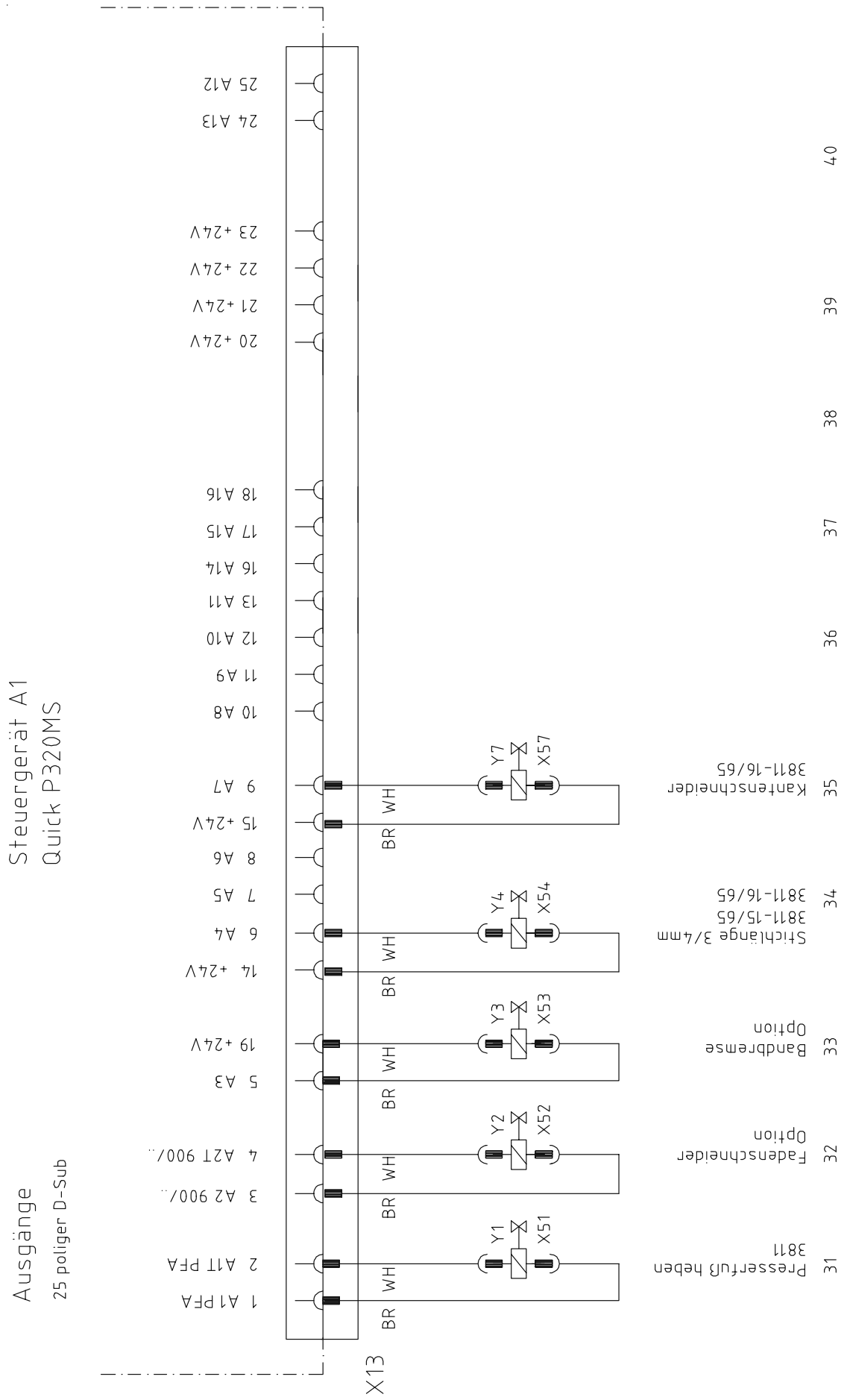

PFAFF

PFAFF Industrie Maschinen AG

Postfach 3020

D-67653 Kaiserslautern

Königstr. 154

D-67655 Kaiserslautern

Telefon: (0631) 200-0

Telefax: (0631) 17202

E-Mail: info@pfaff-industrial.com