

PFAFF

3568^{-2/12}_{-12/12}

Instruction manual

Notes on Safety

- The machine must only be commissioned in full knowledge of the instruction manual and operated by persons with appropriate training.
- Before putting into service also read the safety notes and the instruction manual of the motor supplier.
- The machine must be used only for the purpose intended.
Use of the machine without the safety devices belonging to it is not permitted.
- When gauge parts are exchanged (e.g. needle, presser foot, needle plate, feed dog and bobbin) during threading, when the workplace is left, and during service work, the machine must be isolated from the mains by switching off the main switch or disconnecting the mains plug.
- On mechanically operated clutch motors without start inhibitor it is necessary to wait until the motor has stopped.
- General servicing work must be carried out only by appropriately trained persons.
- Repairs, conversion and special maintenance work must only be carried out by technicians or persons with appropriate training.
- For service or repair work on pneumatic systems the machine must be isolated from the compressed air supply system.
Exceptions to this are only adjustments and function checks made by appropriately trained technicians.
- Work on the electrical equipment must be carried out only by electricians or appropriately trained persons.
- Work on parts and systems under electric current is not permitted, except as specified in regulations EN 50110.
- Conversions or changes to the machine must be made only on adherence to all safety regulations.
- For repairs, only replacement parts approved by us must be used.
- Commissioning of the sewing head is prohibited until such time as the entire sewing unit is found to comply with EC regulations.

Meanings of the symbols:



Danger spot!
Items requiring special attention.



Danger of injury to operative
service staff.

Be sure to observe and adhere to these notes!

Contents

1	Specifications	5
2	Menu functions overview	7
3	Operation elements and information	8
.1	Control panel: sewing station	8
.2	Control panel: folding station	9
.3	Mains switch	11
.4	Start keys	11
.5	Foot switch	11
4	Machine installation	12
5	Connecting compressed air and electricity	12
6	Switching on the machine	14
7	Switching off the machine	14
8	Checks	16
.1	Oil sight glass of sewing machine	16
.2	Hook lubrication	16
9	Inserting the needle	18
10	Winding the bobbin thread	18
11	Regulating the bobbin thread tension	19
12	Changing the bobbin	20
.1	in MANUAL mode	20
.2	in AUTOMATIC mode	20
13	Threading the needle thread	22
14	Regulating the thread tension	24
.1	Needle thread	24
.2	Bobbin thread	24
15	Recalling the main functions	26
.1	Recalling the part functions	26
16	1 - ENTER PROGRAM NUMBER	26
17	2 - ENTER SOURCE	28
18	3 - ENTER SEWING SPEED	28
.1	1 - MAX. SPEED (maximum sewing speed)	28
.2	2 - RED. SPEED (reduced sewing speed)	29
19	4 - SET / RESET OF COUNTERS (Setting, resetting counters)	30
.1	1 - PIECES (piece counter)	30
.2	2 - BOBBIN (bobbin thread stitch counter)	30
.3	3 - PRE-SEL. (pre-selection for bobbin thread stitch counter)	30
.4	4 - DELAY ZZ ON (zigzag delay on)	30
.5	5 - DELAY ZZ OFF (zigzag delay off)	31
.6	6 - SLOW STARTING STITCHES	31
20	5 - READ,DELETE,DIR. OF PROGRAMS (read , delete, directories of programs)	32
.1	1 - DIRECTORY	32

.2	2 - DELETE ONE PROGRAM	32
.3	3 - DELETE ALL PROGRAMS	32
.4	4 - READ ONE PROGRAM FROM EPROM	32
.5	5 - READ ALL PROGRAMS FROM EPROM	32
.6	6 - READ PROGRAMS FROM SER. INTERFACE (Reading programs to memory via interface)	33
21	6 - TIME ADJUSTMENTS	34
.1	1 - TIMING FOR AIR BLAST STACKER	34
.2	2 - TIMING FOR STACKER ROLLER (running time fo material puller)	34
.3	3 - TIMING FOR POSITIONING PIN UP	35
.4	4 - TIMING AFTER PLATE UP	35
.5	5 - TIMING FOR EDGE FOLDERS BACKW.	36
.6	6 - TIMING FOR TRANSFER FORWARD	36
.7	7 - TIMING FOR FOLDER DOWN	36
.8	8 - TIMING FOR PULLER DOWN	37
22	7 - SWITCH FUNCTIONS	38
.1	1 - AIR BLAST SELECTION	38
.2	2 - PULLER (optional)	39
.3	3 - POSITIONING PIN (optional)	39
.4	4 - THREAD MONITOR	39
.5	5 - BOBBIN MONITOR	39
.6	6 - BOBBIN SENSOR	40
.7	7 - PROG. CHANGE A - B	40
.8	8 - PLAIN FABRIC	40
.9	9 - INTERIM STOP	40
.10	10 - FURTHER FUNCTIONS	41
23	8 - ENTER FIXED PROGRAM NUMBERS	41
.1	1 - FIXED PROG. A	41
.2	2 - FIXED PROG. B	41
24	Recalling the service functions	42
25	Programming the function sequence	42
26	Inserting the workpiece	43
27	Sewing	44
.1	"MANUAL" mode	44
.2	"AUTOMATIC" mode	44
28	Disturbances	44
29	Maintenance and care	46
.1	Oil sight glass of the sewing machine	46
.2	Lubrication of carriage guides to the X-Y control of the sewing jig	46
.3	Cleaning the machine	46
.4	Air filter/lubricator	48
.5	Cleaning the blower air filter	50
.6	Recommended lubricants	50

1 Specifications

Application:	Mechanised sewing unit for folding and sewing pockets on jeans, workwear and similar pieces.
Sewing head 3568-2/12:	PFAFF 418
Sewing head 3568-12/12:	PFAFF 918
Stitch types:	301 (lock stitch) 304 (zigzag lock stitch)
Max. sewing speed:	4,100 r.p.m.
Max. stitch length:	6 mm
Needle system:	1955-07-MR5
Needle strength:	70 to 140 Nm
Table top height:	adjustable within a range of 955 mm to 1,060 mm
Sewing motor:	Quick QE 5542 - P 143 SE
Max. motor speed:	4,200 r.p.m.
Mains tension:	230 Volt 50/60 cycles AC
Power input:	approx. 1,000 VA
Min. air pressure:	6 bar
Air consumption:	approx. 27 litres per cycle
Noise:	workplace-related noise at sewing speed $n = 4,100 \text{ r.p.m.}: L_{pA} < 78 \text{ dB(A)}$
Unit dimensions:	Length: 2,200 mm Width: 1,500 mm Height: 1,400 mm
Weight:	approx. 653 kg net approx. 840 kg gross

Subject to technical modifications.

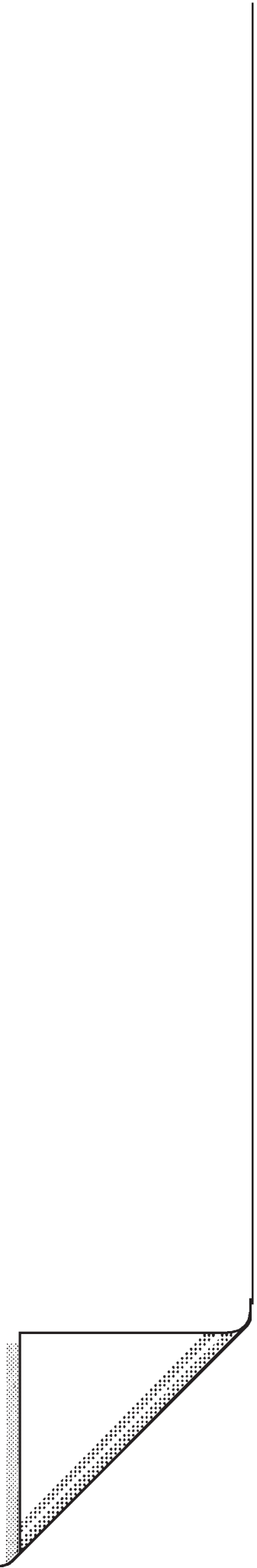

2 Overview of menu functions

Main functions	Sub-functions	Sub-functions
Normal state		
1— ENTER PROGRAM NUMBER		
2— ENTER SOURCE	1— EPROM 2— MEMORY	
3— ENTER SEWING SPEED	1— MAX. SPEED 2— RED. SPEED	
4— SET / RESET OF COUNTERS	1— PIECES 2— BOBBIN 3— PRE-SEL. 4— DELAY ZZ ON 5— DELAY ZZ OFF 6— SLOW STARTING STITCHES	
5— READ, DELETE, DIR. OF PROGRAMS	1— DIRECTORY 2— DELETE ONE PROGRAM 3— DELETE ALL PROGRAMS 4— READ ONE PROGRAM FROM EPROM 5— READ ALL PROGRAMS FROM EPROM 6— READ PROGRAMS FROM SER. INT.	1— DIR. (EPROM) 2— DIR. (MEMORY)
6— TIME ADJUSTMENTS	1— TIMING FOR AIR BLAST STACKER 2— TIMING FOR STACKER ROLLER 3— TIMING F. POSITIONING PIN UP 4— TIMING AFTER PLATE UP 5— TIMING F. EDGE FOLDERS BACKW. 6— TIMING FOR TRANSFER FORWARD 7— TIMING FOR FOLDER DOWN 8— TIMING FOR PULLER DOWN	
7— SWITCH FUNCTIONS	1— AIR BLAST SELECTION 2— PULLER 3— POSITIONING PIN 4— THREAD MONITOR 5— BOBBIN MONITOR 6— BOBBIN SENSOR 7— PROG. CHANGE A-B 8— PLAIN FABRIC 9— INTERIM STOP 0— FURTHER FUNCTION	1— N. COOLING, TR. FOR. 2— N. COOLING, STACKER 3— FAB. FEED, TR. FORW. 4— FAB. FEED STACKER 5— FAB. FEED SEWING 1— AUTO HEAD LIFT 2— LABEL FEEDER 3— LABEL ALTERATION
8— ENTER FIXED PROGRAM NUMBERS	1— FIXED PROG. A 2— FIXED PROG. B	



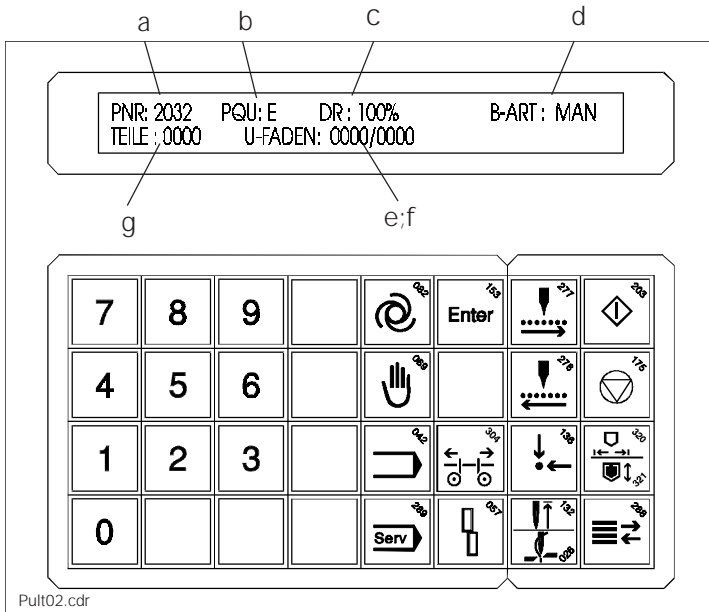

3 Operation elements and information

3.1 Control panel: Sewing station





- Indications on the display:
- a = Program number
 - b = Program source
 - c = Speed indication in %
 - d = Mode display
 - e = Bobbin thread stitch counter. current value/ input value
 - f = Dialog display for input and service
 - g = Piece counter













Mode keys

-  Automatic control
-  Manual control
-  Input
(press key before main or sub-functions are inputted)
-  Service
(press key before service functions are inputted)

Numeric keys

-  to  Input of numeric values and direct menu selection

Function keys

-  1. Call main and sub-functions from Service  and Input 
- 2. Accept new inputs
-  Bobbin change from above or stacker forwards - backwards
-  Error reset
(after removing fault or bobbin change)
-  Cycle sewing jig forward
-  Cycle sewing jig backwards
-  Sewing program in basic position
-  Position needle up
-  Sewing start
Program continued after stop
-  Program stop
-  Jig feed arm FWD - BWD
(if "changeover to sewing "on")
Jig up - down
(if "changeover to feed "on")
-  Stacker FWD - BWD

3.2 Control panel: Folding station

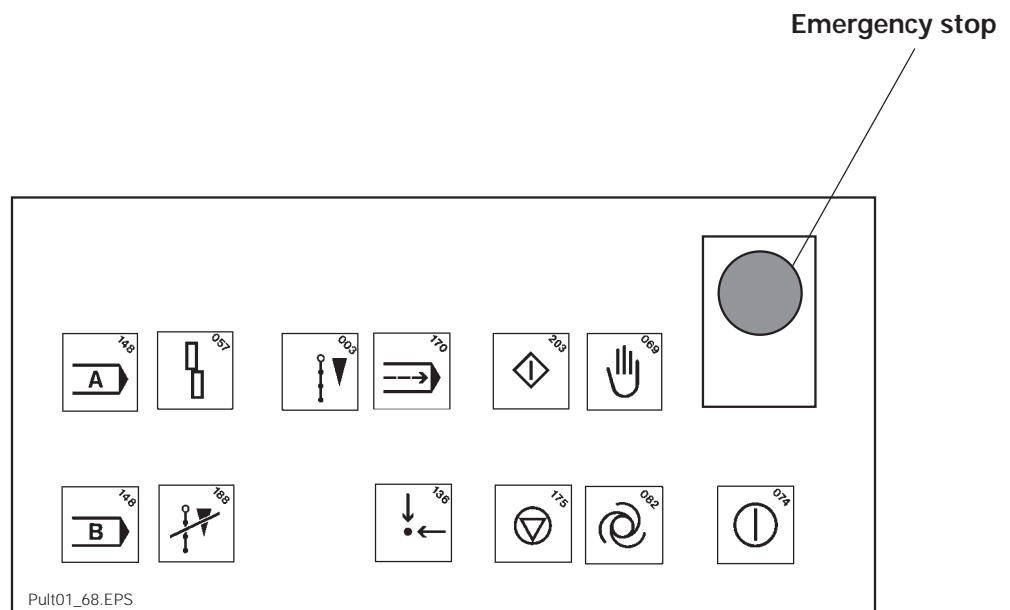

Mode keys



Manual control



Automatic control

Function keys



Program selection in functions:



program change A - B (see 22.7)



Error reset

(after removing fault or bobbin change)

Function keys



Machine on



Program stop



Disable STOP



Sewing "on" in "MANUAL" mode



Function sequence in increments in
"MANUAL" mode (without sewing action)



Folding unit and jig feed in
basic position



no sewing

(sewing start is disabled)

3.3 Main switch

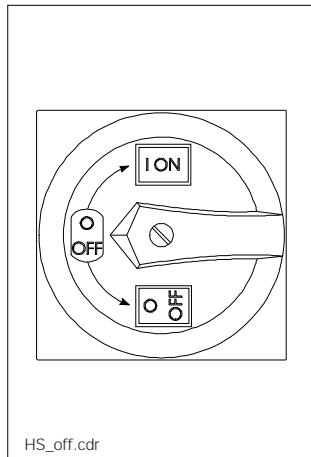

0 = off
1 = on

3.4 Start keys

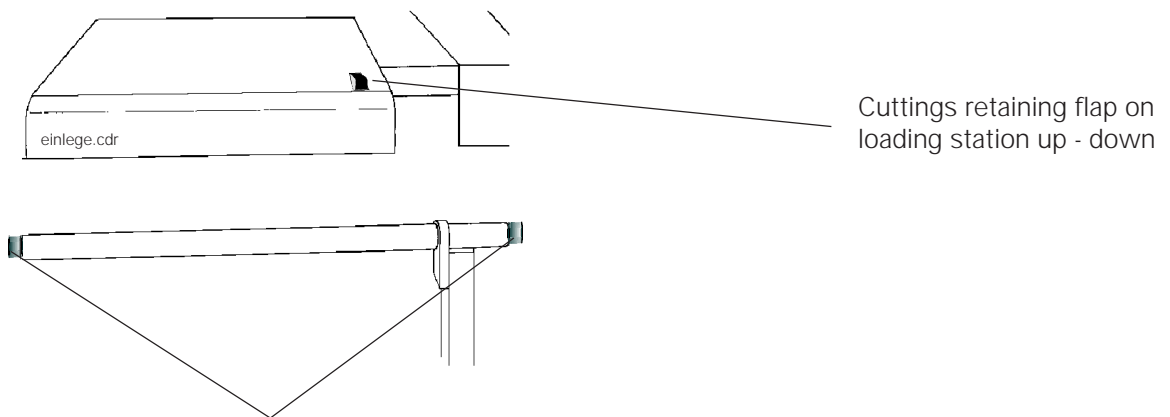

In mode: MANUAL

- Folder forwards (for processing checked and striped material)
- Pocket plate off, folder forwards (for processing unicoloured material)
- Program continuation after bobbin change from above

In mode: AUTO

- Program start
- Program continuation after bobbin change from above

3.5 Foot switch

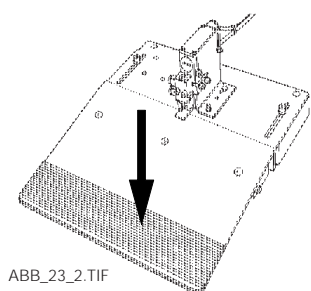

Pocket plate down (for operations on checked or striped materials)

When foot switch is pressed, pocket plate stays up to allow positioning of stripes or checks

Foot switch not needed for plain materials

4 Machine installation

Note: In case of damage due to transportation inform the transportation company and the respective PFAFF agency.

- .1 Lift machine off the transportation pallet by means of a fork lifter.
- .2 Turn the six rubber buffer elements delivered with the accessories (fig. 1) into feet 2.
- .3 Lower machine down on the floor and adjust it horizontally by shifting feet 2.
- .4 Connect stacker stand 3 (fig. 2) on the front side of the machine.

Check hook lubrication by all means (see section 8.2) on machines that are put into operation for the first time or that have not been used for a longer period (approx. 2 to 3 months).

5 Connecting for compressed air and electricity

5.1 Compressed air

Connect compressed air tube (inner diameter 6 mm) to coupling 4 (fig. 3).

Minimum network pressure:	7 bar
Working pressure:	6 bar
Pressure regulation:	Valve 5

5.2 Electricity

- .1 Permissible operating voltage is indicated in box 6 (fig. 4).
- .2 Connection is permissible only if mains and operating voltage are the same.
- .3 Machine must only be connected to an earthed plug.

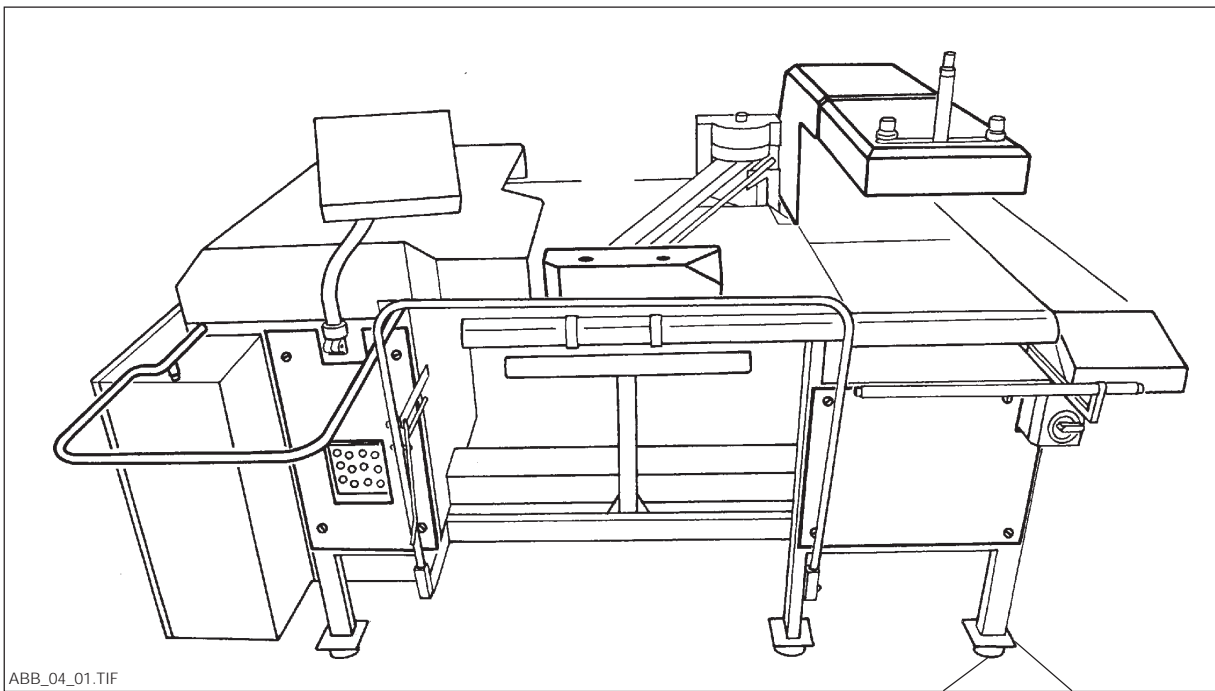

ABB_04_01.TIF

1

1 2

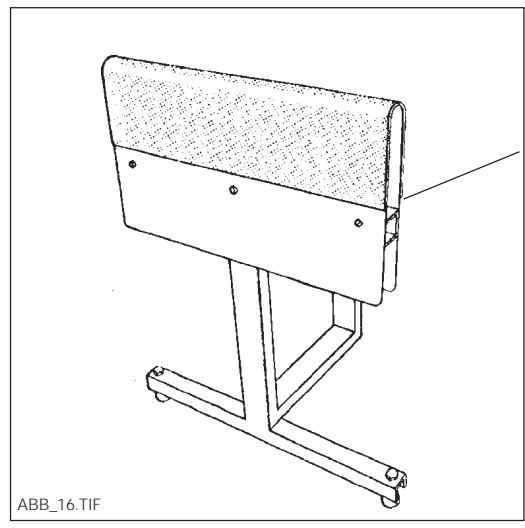

ABB_16.TIF

2

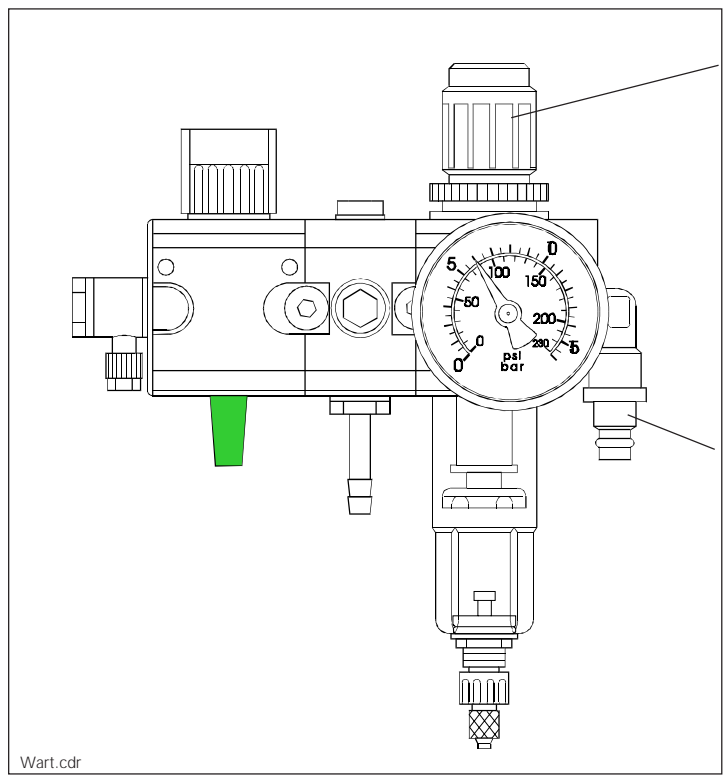

Wart.cdr

5

4

3

PFAFF	
<input type="text"/>	T.-Nr. <input type="text"/>
Stromart <input type="text"/>	Frequenz <input type="text"/> Hz
Betriebsspg. <input type="text"/>	<input type="text"/> V
Steuersp. <input type="text"/>	Trafo <input type="text"/> V
Nennstrom <input type="text"/>	<input type="text"/> A
Hauptsicherung <input type="text"/>	<input type="text"/> A
Schaltplan <input type="text"/>	<input type="text"/>

6



4

6 Switching on the machine

- .1 Open compressed air on main feed tube.
- .2 Open valve 1 (fig. 1).
- .3 Check working pressure: 6 bar (pressure gauge 2).
- .4 If necessary, carry out an additional regulation of the air pressure (regulating button 3.).
- .5 Turn main switch 4 (fig. 2) to "1":

- Key  lights up
(Emergency-stop button 5, fig 4 must be unlocked.)



- .6 Press key .

- Guide carriage is positioning in basic position.
- Keys  and  light up.
- Machine is operational for "manual operation".

Note: For "automatic working procedure" also press key .

- Keys  and  light up.

- .7 Press key .

- Key  lights up
- Key  goes out.
- Machine is operational.

7 Switching off the machine

Set main switch 4 (fig. 3) at "0" and close valve 1 (fig. 1).



If for some reason the machine is to be switched off immediately, press EMERGENCY-STOP button 5 (fig. 4).

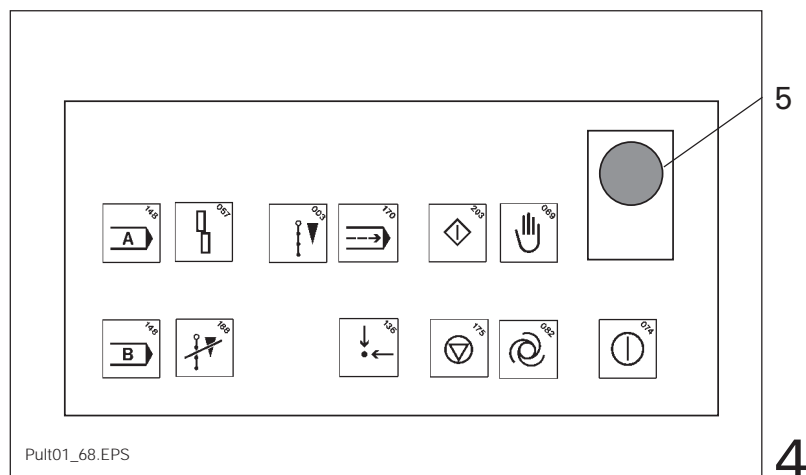
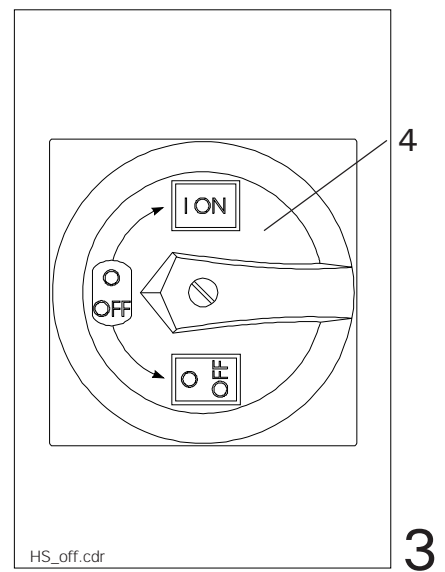
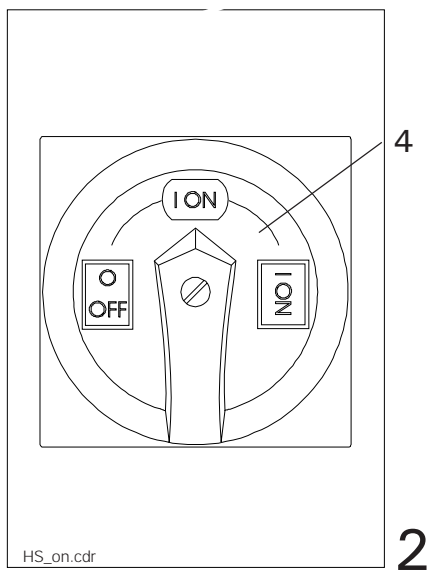
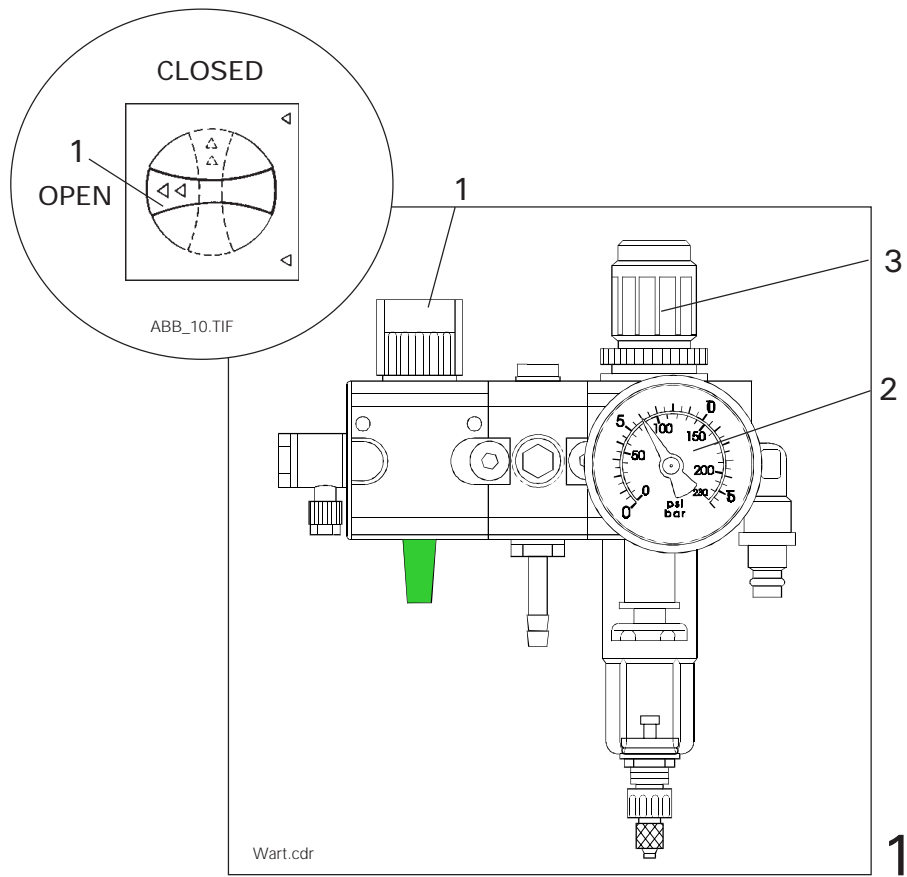

8 Checks

8.1 Oil sight glass of the sewing machine

Consider max. and min. oil levels.

Hook lubrication: If necessary, top up (hole1, fig. 1 or 2) oil (see section 29.6, "Recommended lubricants").

Zigzag drive: If necessary, top up oil (see section 29.6, Recommended lubricants); to this end unscrew screw 2 (fig. 2 or 3).

8.2 Hook lubrication

Requirement: After the machine has run for ten seconds at full speed, a thin oil line should build up on a piece of paper that is held towards the side of the hook.

Basic adjustment: Turn regulating screw 3 (fig. 5 or 6) fully in and then out again by half a turn.

.1 Switch on the machine.

.2 Press keys  and **4** :
- Positioning speed is pre-selected.

.3 Press keys **1** and **5** :
- Maximum speed is pre-selected.

.4 Press key  :
- Sewing motor is running.

.5 Let machine run at full speed for approx. one minute.

.6 Hold piece of paper towards the hook and let machine run for ten seconds, (see requirement).

.7 Stop machine with key .

.8 Oil regulation: screw 3..

3568-2/12

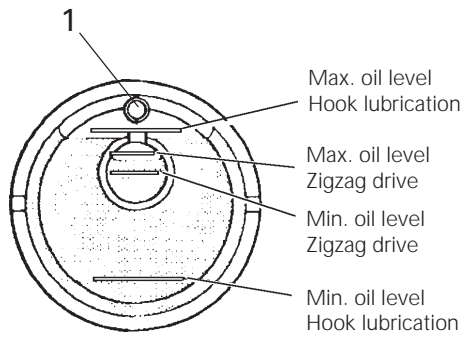

ABB_17.TIF

1

3568-12/12

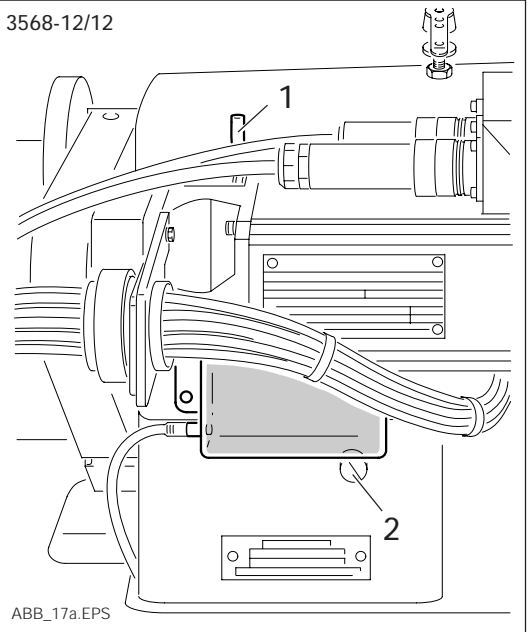

ABB_17a.EPS

2

3568-2/12

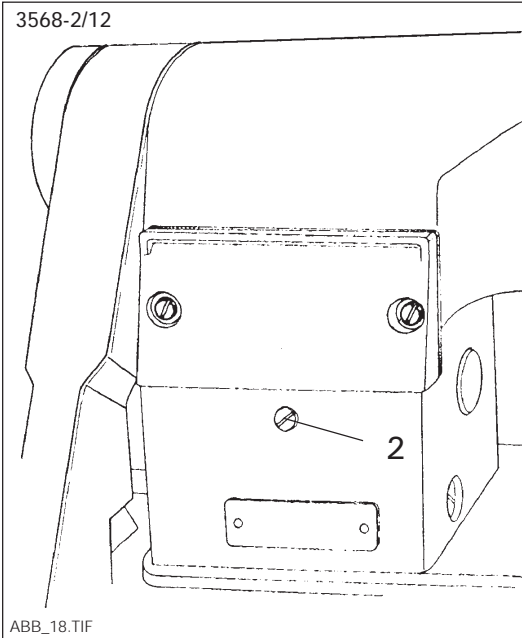

ABB_18.TIF

3

3568-12/12

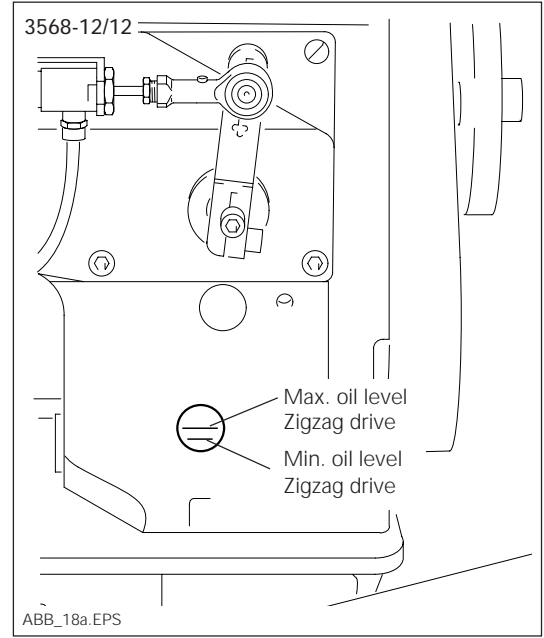

ABB_18a.EPS

4

3568-2/12

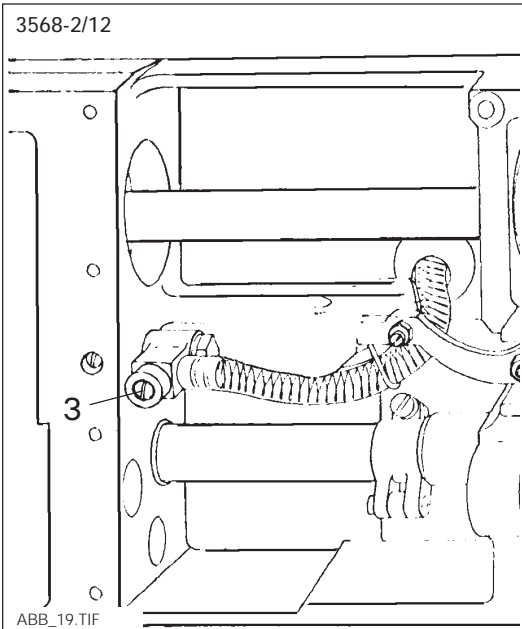

ABB_19.TIF

5

3568-12/12

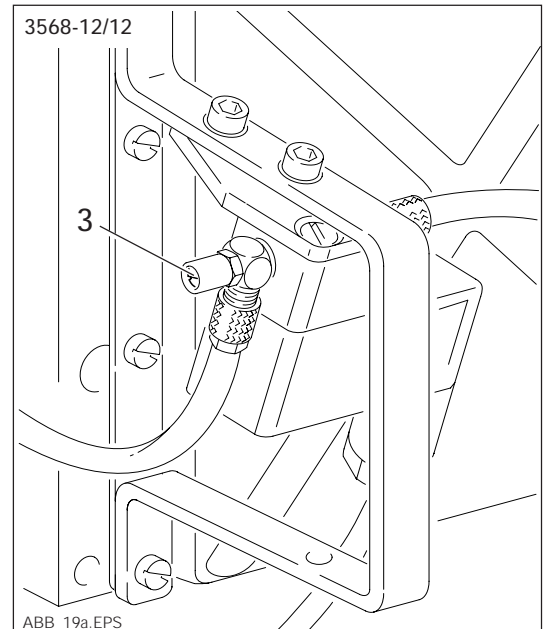









ABB_19a.EPS

6

9 Inserting the needle

Needle system 1955-07-MR5

- .1 Press key  :
- Operation mode " manual" .
- .2 Press key  :
- Changeover for sewing on.
- Changeover for feed off.
- .3 Press key  :
- Jig feed arm is swivelling to folding station.
- .4 Disconnect locking lever 1 (fig. 1) and swing safety bar 2 fully towards the machine.
- Key  lights up
- Machine is disabled.
- .5 Push needle fully in with the long groove facing the folding station.
- .6 Swing safety bar 2 (fig. 1) back to original position:
- Key  lights up,
- key  goes out.
- .7 Press key  :
- Jig feed arm swivels to the sewing machine.

Press key  :
- Changeover for feed on.
- Changeover for sewing off.

10 Winding the bobbin thread

- .1 Place the empty bobbin on spindle 3 (fig. 2).
- .2 Thread the thread according to fig. 2 and wind it clockwise around the bobbin by a few turns.
- .3 Switch on winder; to this end press spindle 3 and cam 4 at the same time (arrows in fig. 2).
- .4 The bobbin should be filled whilst sewing.
- .5 Regulating the filling amount: shift cam 4 (screw 5).
- .6 In case of irregular winding: adjust thread guide 6 and regulate bobbin thread tension.

11 Regulating the bobbin thread tension

Knurled disc 11 (fig. 7)

- + = tighter
- = looser

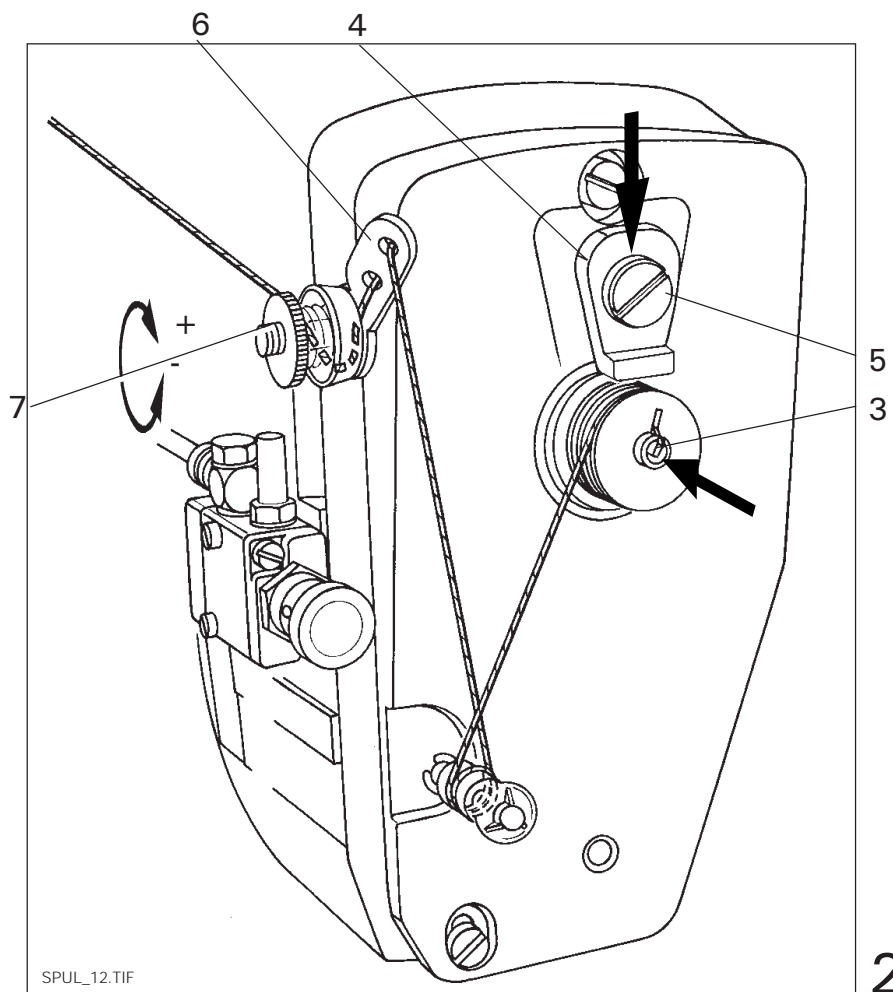
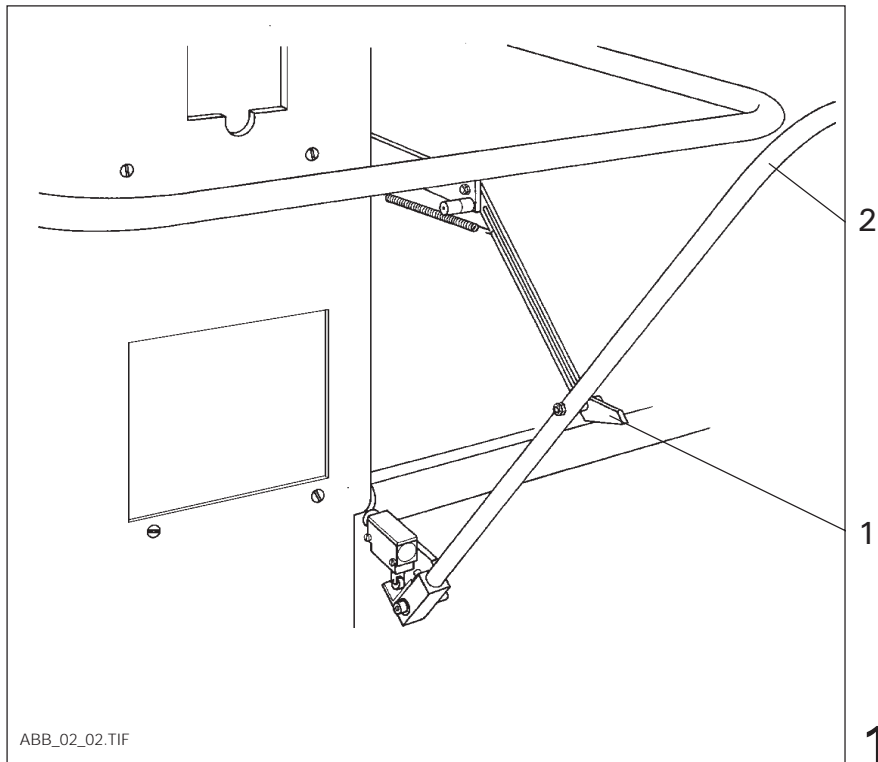

12 Changing the bobbin

(Bobbin change with option "Bobbin change from above" is described. The option must be switched on, see page 41: - 1- AUT. LIFT HEAD-
In the standard version there is no need to lift the head because the bobbin can be changed only from below.)

12.1 In MANUAL mode

.1 Press key .

- Sewing jig is moving to folding station.
- Head is lifting up.

.2 Disconnect locking lever 1 (fig. 1) and swing safety bar 2 fully towards the machine.

- key  lights up and machine is disabled.



The bobbin must only be changed when safety bar 2 is swung towards the machine; otherwise risk of injury.

.3 Open latch 3 (fig. 2) and take out bobbin case.

.4 Insert bobbin in bobbin case so that it turns as shown by arrow (fig. 3) when the thread is pulled.

.5 Hold bobbin in position, insert thread into slot 4 and pull it through underneath the tension spring until it reappears behind spring eyes.
Then insert the thread into slots 6 and 7 and pull it right into the holes.

.6 Insert bobbin case with bobbin into the hook.

.7 Close latch and press it slightly to make sure that bobbin is locked securely.

.8 Swing back safety bar 2 to its original position.

.9 Press the two start buttons on the loading station:
- Head moves down.
- Sewing jig moves to sewing station.

12.2 In AUTOMATIC mode

Note: After the pre-selected number of stitches in the bobbin thread stitch counter has been reached, the sewing jig moves to the folding station where it stops.

The message CHANGE BOBBIN appears and key  lights up.

The head is lifted automatically.

.1 Carry out bobbin change according to sections 12.1.2 to 12.1.8.

.2 Press key  :







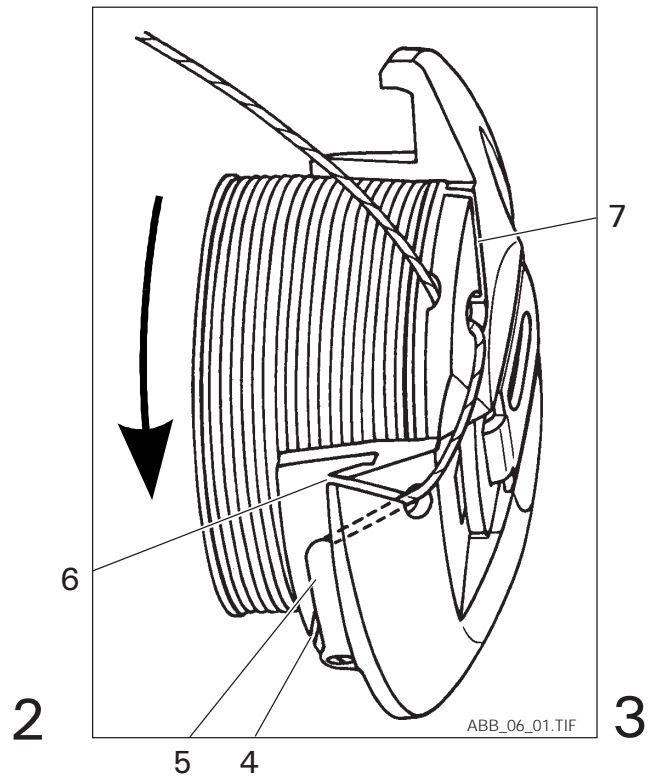
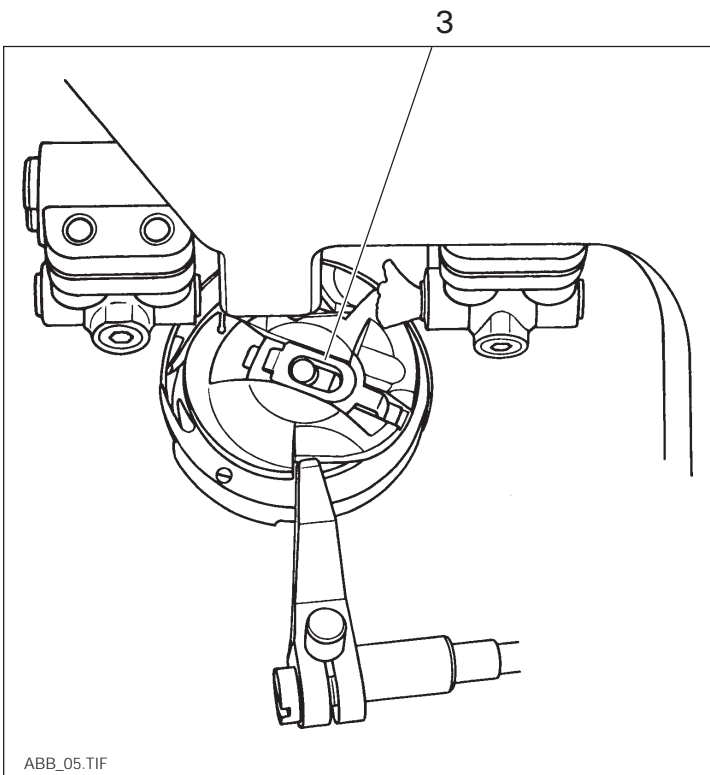
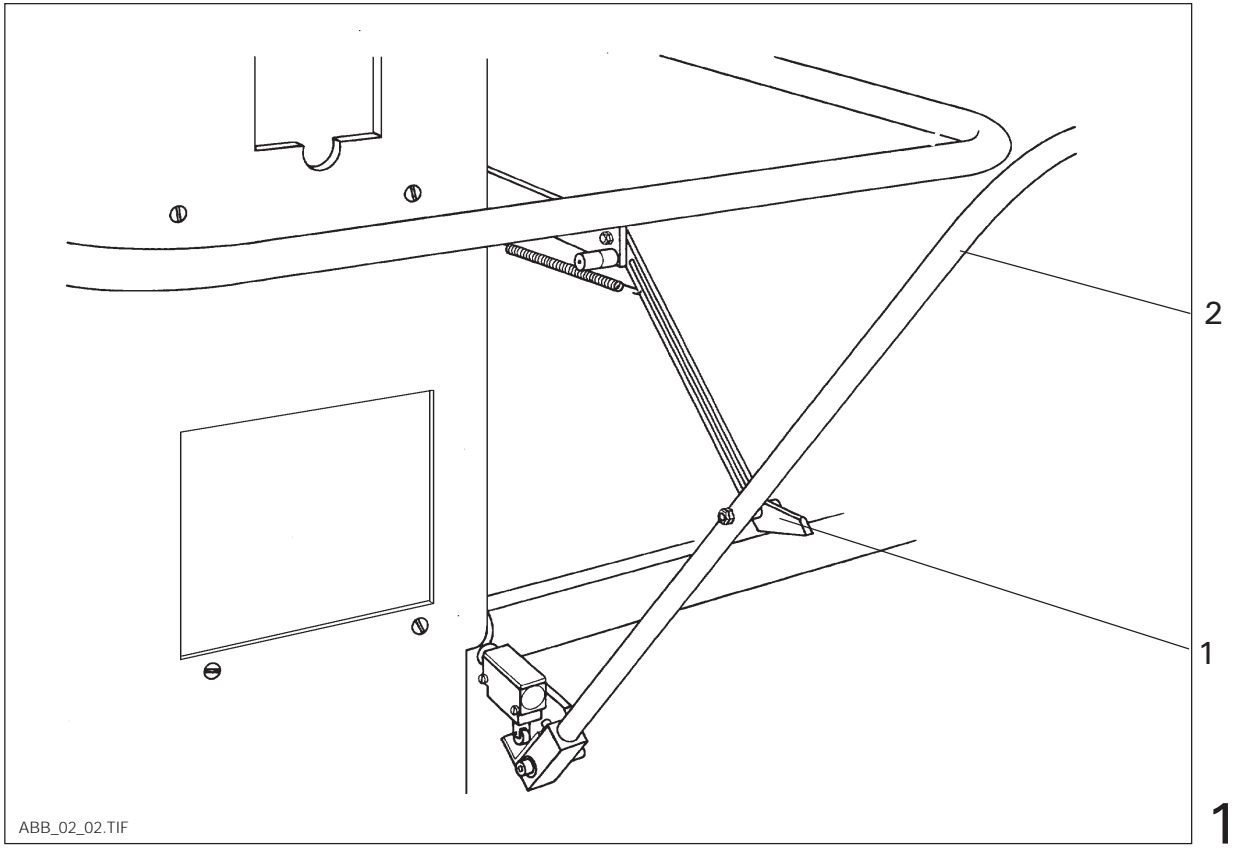

- Key is extinguished.

.3 Press the two start buttons on the loading station:
- Program is continued.

Note: With a machine stop during the sewing program it is possible to change the bobbin only from below since the head cannot be lifted.



13 Threading the needle thread

- .1 Press key  :
 - Mode "Manual operation" .
- .2 Press key  :
 - Change-over for sewing on.
 - Change-over for feed off.
- .3 Press key  :
 - Jig feed arm swivels to folding station.
- .4 Release locking lever 1 (fig. 1) and swing safety bar 2 fully towards the machine:
 - Key  lights up.
 - Machine is disabled.
- .5 Thread the thread according to fig. 2.
- .6 Before the thread is threaded through thread clamp 3, press push-button 4 (fig. 3) and hold it pushed:
 - Thread clamp opens.
- .7 Swing safety bar 2 back to its original position:
 - Key  lights up,
 - key  goes out.
- .8 Press key  :
 - Jig feed arm swivels to sewing station.
- .9 Press key  :
 - Change-over for feed on.
 - Change-over for sewing off.

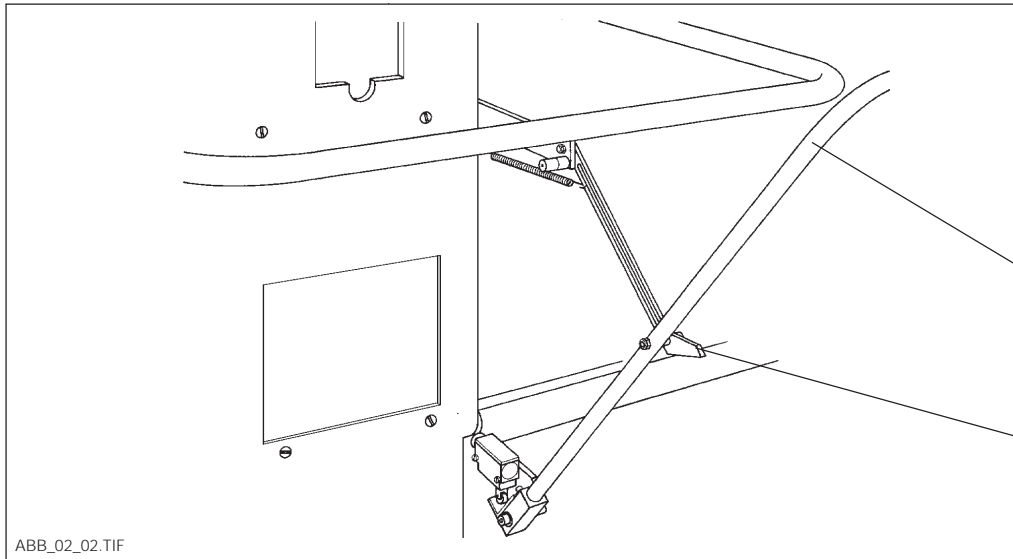

2
1
1

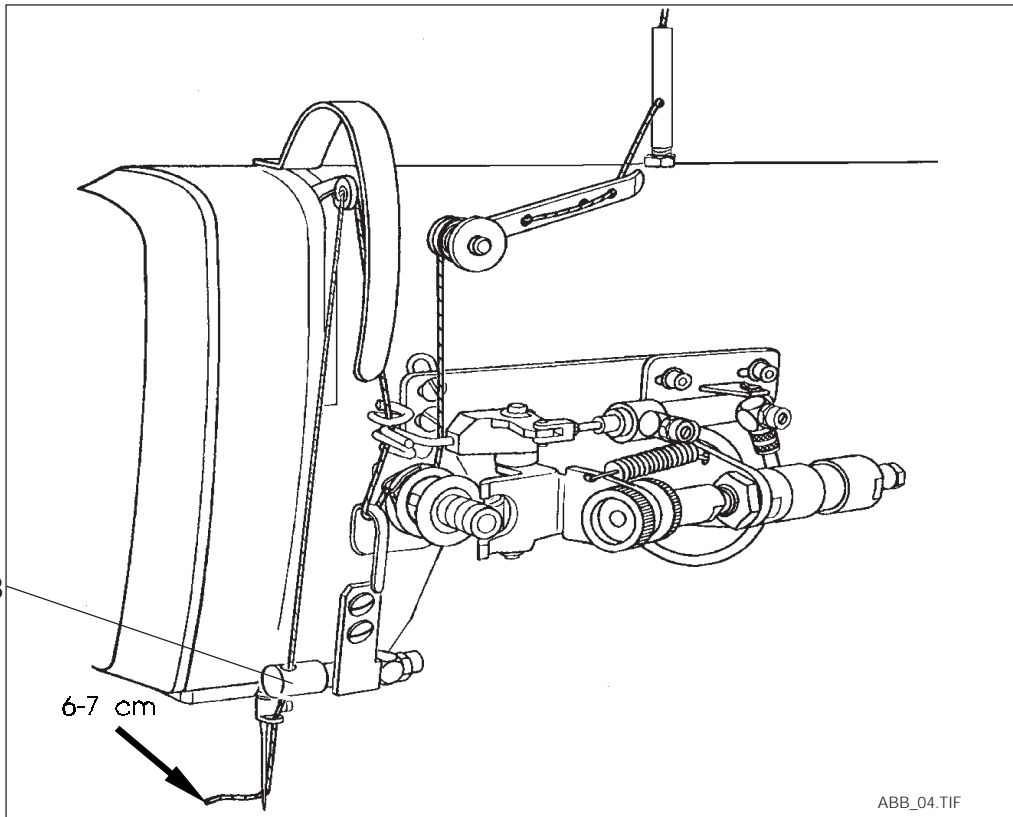

2

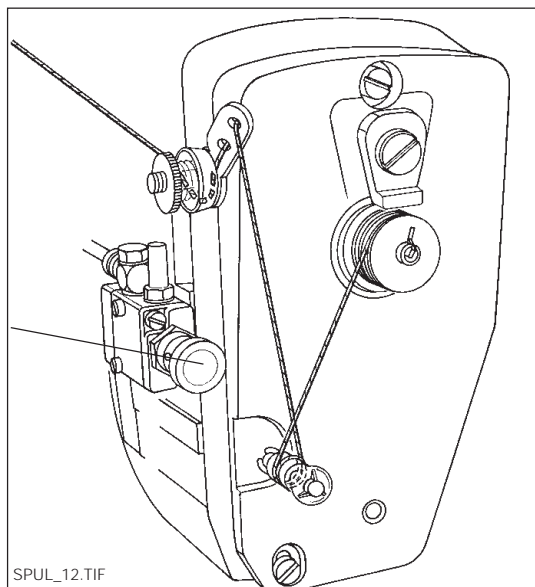

3

14 Regulating the thread tension

14.1 Needle thread (fig. 1)

Primary tension = knurled nut 1

Main tension = nut 2

+ = to increase tension

- = to decrease tension

14.2 Bobbin thread (fig. 2)

Screw 3

+ = to increase tension

- = to decrease tension

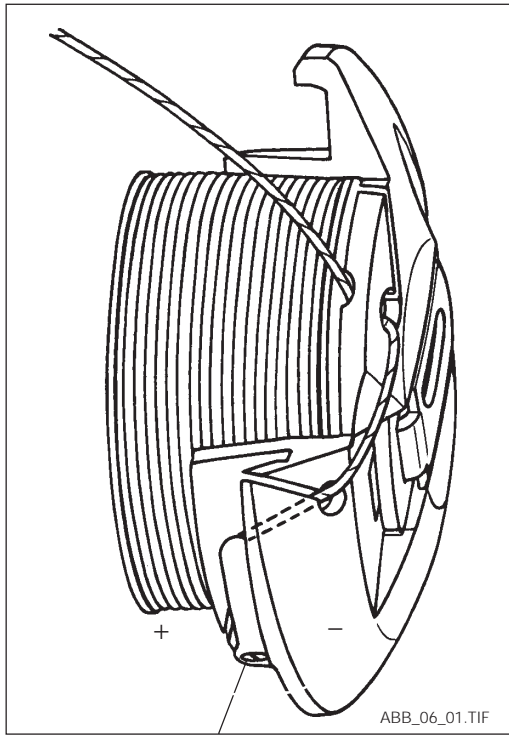
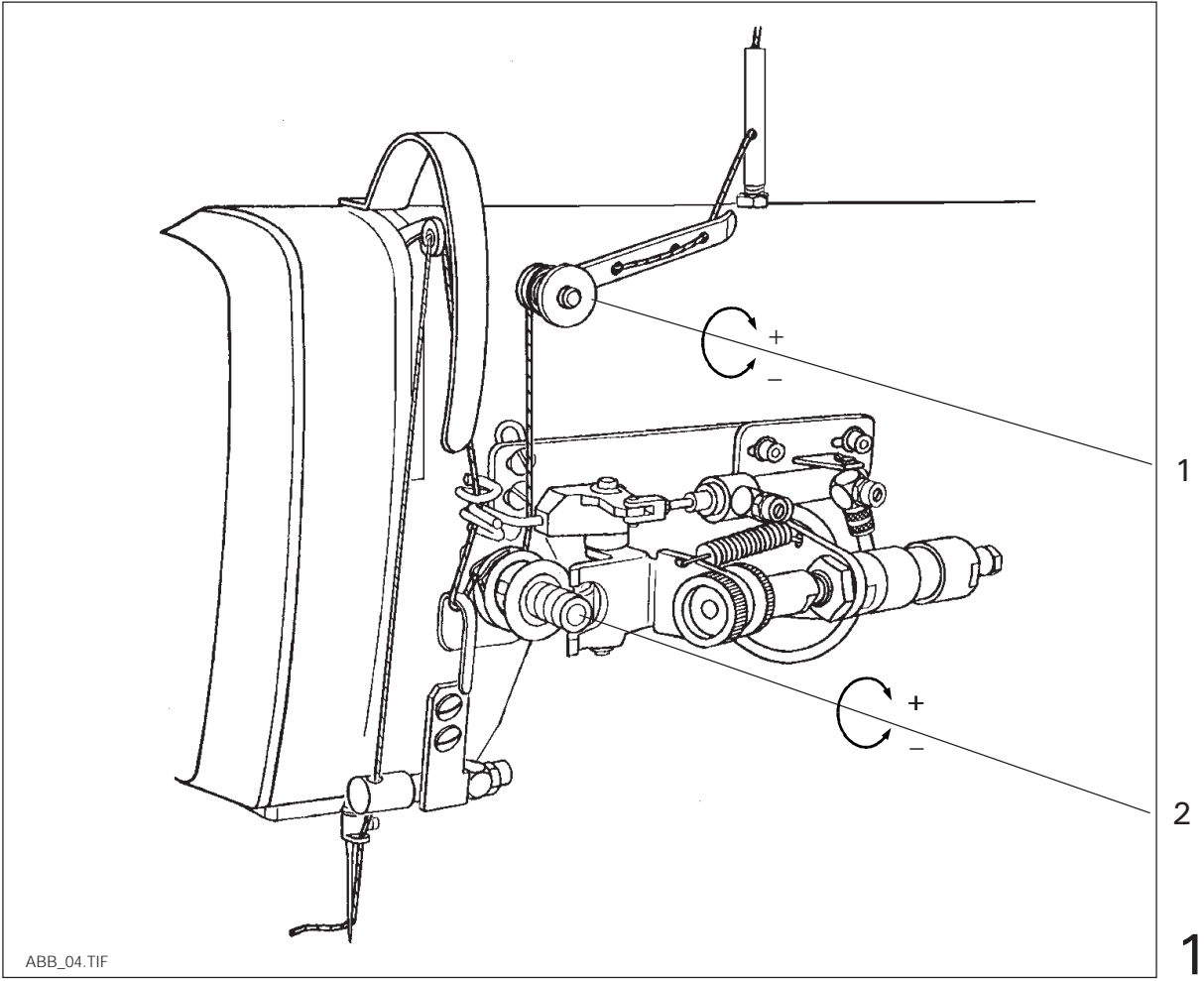

15 Recalling the main functions

During the basic state of the input all main functions can be shown along with their function numbers by means of key .





Switch on machine.

Press key  :

- Input

By pressing key  repeatedly the main functions are displayed:

- 1 - ENTER PROGRAM NUMBER
- 2 - ENTER SOURCE
- 3 - ENTER SEWING SPEED
- 4 - SET / RESET OF COUNTERS
- 5 - READ, DELETE, DIR. OF PROGRAMS
- 6 - TIME ADJUSTMENTS
- 7 - SWITCH FUNCTIONS
- 8 - ENTER FIXED PROGRAM NUMBERS

By pressing either key    or  the input is verified.

15.1 Recalling the sub-functions

In a main function all existing sub-functions can be displayed along with their function numbers by pressing key  (see section 2 " menu functions overview").

16 1- ENTER PROGRAM NUMBER

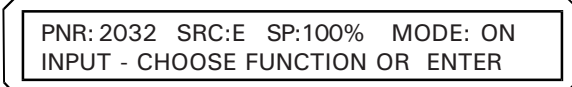

Entering the program number is only possible when the machine is in basic position.

Press key  on the control panel of the sewing station:

Display: 

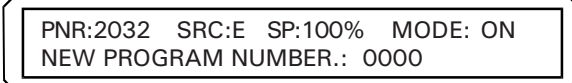
Press key  :



Display: 

Enter the desired program number: Keys  to  (e.g. 0100).

Press key  :

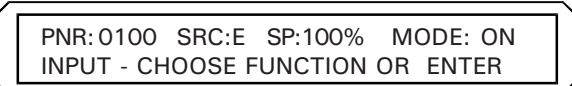
- The program number is taken over and appears in the top left-hand corner of the display *.

Display: 

Press either one of the two operation mode keys  or  :
- Input is finished.

Note: When changing over to another program consider whether sewing jig and folding parts kit have to be changed as well.

* If the selected program number does not exist in the current program source, a message is displayed when starting sewing or cycling through.

Display:

PNR: 0100 SRC: E SP: 100% MODE: ON
*ERR: NO SUCH PROGRAM

17 2 - ENTER SOURCE

Entering a program source is only possible when the machine is in basic position.

Press key 

Display: 

Press numeric key 

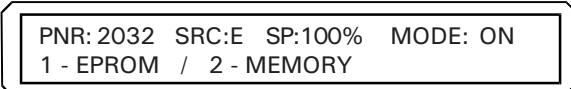
Display: 

If the current program number is in the selected program source, the new program source is taken over and the program can be worked.*

* If the current program number is not in the selected program source (EPROM or MEMORY), a message and the entered number are displayed (ERROR: NO PROGRAM NR.) after pres-

sing key .

18 3 - ENTER SEWING SPEED

The following can be displayed and edited:

- the maximum sewing speed
- the reduced sewing speed.

The sewing speed can be entered in steps of 1 to 15, level 15 meaning full speed (= 100%).

With each step the sewing speed is changed by 5 % between 100 % and 40 % and from 40 % onwards by 10 %.

The percentage appears in the display.

18.1 1 - MAX. SPEED (Max. sewing speed)

Press key 

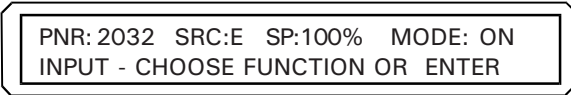
Display: 

Press numeric key 

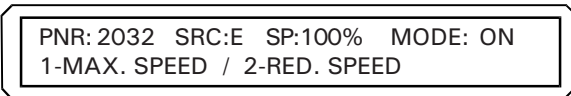
Display: 

Press numeric key 

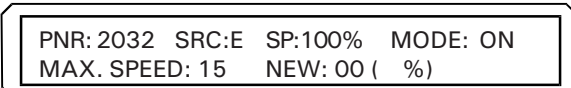
Display: 

In the bottom line of the display the current speed level (e.g. MAX 15) is shown.

By pressing numeric keys **0** to **9** it is possible to enter the desired speed level which is displayed in %.

By pressing the **Enter** key the value will be taken over.

18.2 2 - RED. SPEED (reduced sewing speed)

Press key 

Display: 

Press numeric key **3**

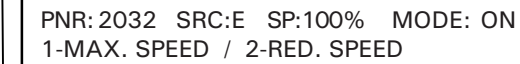
Display: 

Press numeric key **2**

Display: 

The current speed level is shown in the bottom line of the display (e.g. RED. SPEED: 15).

By pressing numeric keys **0** to **9** it is possible to enter the desired speed level which is displayed in %.

By pressing the **Enter** key the value will be taken over.

19 4 - SET / RESET OF COUNTERS (Setting/Resetting the counters)



19.1 1 - PIECES (Piece counter)

The piece counter counts continuously the attached pockets.

To reset it back to "0" press key 

Display:

PNR: 2032 SRC:E SP:100% MODE: ON
INPUT - CHOOSE FUNCTION OR ENTER

Press numeric keys   and  in this order. Then press an operation mode key .

19.2 2 - BOBBIN (Bobbin thread stitch counter)

The bobbin thread stitch counter counts the sewn stitches in units of 100 stitches each.



The number of stitch units that can be sewn with a filled bobbin thread bobbin, must be determined individually.

Every 100 stitches the stitch counter counts one unit until the preselected value is reached. The started seam is finished and the program stops at position "jig feed back". The following message is displayed:

Display:

CHANGE BOBBIN



Carry out bobbin change according to section 12 now.

If the bobbin is to be changed earlier (i.e. before the pre-selected value is reached), the bobbin thread stitch counter must be resetted by pressing key  and numeric keys   and

 .

19.3 3 - PRE-SEL. (Pre-selection for bobbin thread stitch counter)

Enter the determined value in the pre-selection; to this end press key  and numeric keys

 and  .

Then enter the setting value by pressing numeric keys  to  and verify it by pressing

the  key.

19.4 4 - DELAY ZZ ON (Delay for zigzag on)

The command for "zigzag on" is programmed seven stitches before backtack start. Due to the delay caused by switching valve and cylinder it is necessary to give the command in dependence of the speed.

When changing the sewing speed it is necessary to change also the number of stitches between the command "zigzag on" and the backtack start (fig. 1).

Press key  and press numeric key **4** twice.

The current delay value is shown as a number of stitches. Enter a new value by pressing numeric keys **0** to **9** and verify it by pressing the  key.

19.5 5 - DELAY ZZ OFF (Delay for zigzag off)

The command for "zigzag off" is programmed seven stitches before the backtack end. Due to the delay caused by switching valve and cylinder it is necessary to give the command in dependence of the speed.

When changing the sewing speed it is necessary to change also the number of stitches between the command "zigzag on" and the backtack end (fig. 2).

Press key  and numeric keys **4** and **5** .

The current delay value is shown as a number of stitches. Enter a new value by pressing numeric keys **0** to **9** and verify it by pressing the  key.

19.6 6 - SLOW STARTING STITCHES



At seam start it is possible to sew up to nine stitches at a reduced speed.

Press key  and numeric keys **4** and **6** .

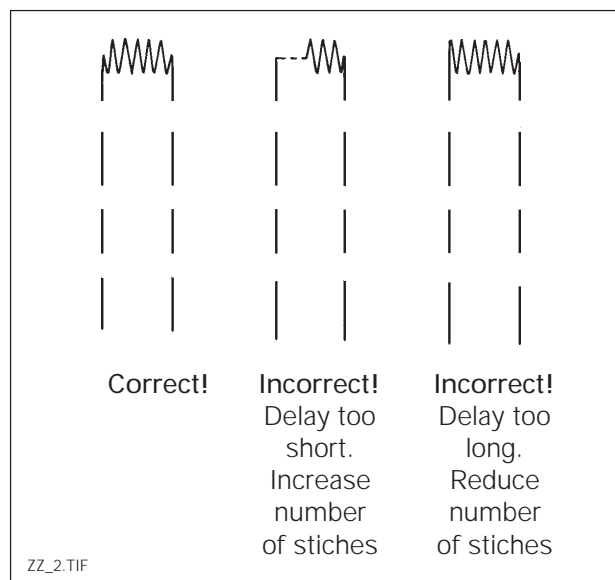
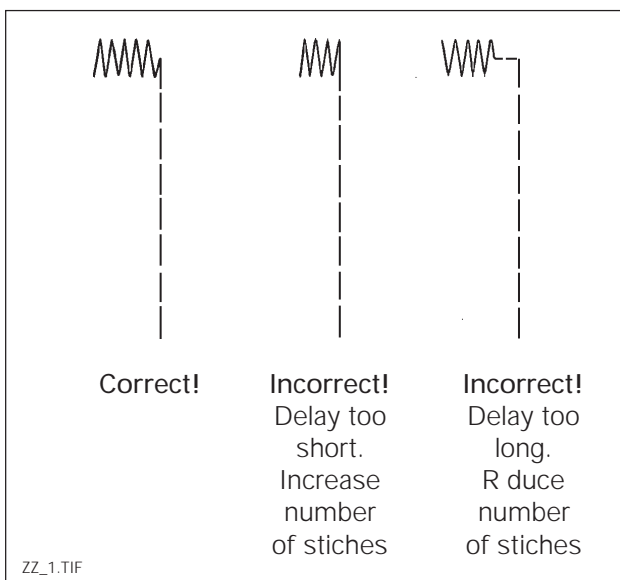
Enter the desired amount of starting stitches with numeric keys **0** to **9** and verify this value by pressing the  key.







20 5 - READ, DELETE, DIR. OF PROGRAMS (Read, delete, directory of programs)

After pressing key  and numeric key  it is possible to browse through the possible sub functions with the  key.

The respective function number is always displayed along with its part function.

20.1 1 - DIRECTORY

After pressing numeric key  it is possible to display the programs existing in the EPROM by pressing numeric key  anew; and the programs existing in the MEMORY by pressing numeric key .

If one line is not sufficient to display all existing programs, it is possible to continue the display by pressing the  key.

After the last program number END is displayed.

20.2 2 - DELETE ONE PROGRAM (Cancelling individual programs)

Programs can only be cancelled when machine is in basic position.

Having pressed numeric key  enter the number of the program to be cancelled.



Press the  key - the cancelling procedure is carried out and then verified.

20.3 3 - DELETE ALL PROGRAMS

Having pressed numeric key  press the  key.

- all programs are cancelled and the cancelling procedure is verified.

20.4 4 - READ ONE PROGRAM FROM EPROM (Reading a program from the eprom to the memory)

Having pressed numeric key  enter the number of the program to be read in and press the  key.

- the reading procedure is started.

If the program cannot be found in the eprom, or the same program number does already exist in the memory, or the memory capacity is not sufficient, a corresponding error message will be displayed.

20.5 **5 - READ ALL PROGRAMS FROM EPROM (Reading all program from the eprom to the memory)**

After pressing numeric key **5** press the **Enter** key.

- the programs are read in and the reading procedure is verified after its conclusion.

20.6 **6 - READ PROGRAMS FROM SER. INT. (Reading programs to the memory via the interface)**

After pressing numeric key **6** the machine is ready for transfer.

The transfer procedure is started from the personal computer.

When the reading procedure is over it is either verified or an error message is displayed.

21 6 - TIME ADJUSTMENTS

21.1 1 - TIMING FOR AIR BLAST STACKER

The duration of the air blast must be regulated so that the workpiece to be stacked is blown securely on top of the stacker stand.

In order to increase or decrease the duration of the air blast press key  and numeric keys

 and .

In the bottom line of the display the following appears:

 along with the entered value in seconds.

Enter a new value by pressing numeric keys  to  and verify it by pressing the  key.

21.2 2 - TIMING FOR STACKER ROLLER (Running time of stacker roller)

The stacked workpieces must rest in a centered position on top of the stacker stand (fig. 1).

In order to increase or decrease the running time of stacker roller press key  and numeric

keys  and .

In the bottom line of the display the following appears:

 along with the entered value in seconds.

Enter a new value by pressing numeric keys  to  and verify it by pressing the  key.

21.3 3 - TIMING F. POSITIONING PIN UP

(No setting required)

21.4 4 - TIMING AFTER PLATE UP

The folding plate must be lifted before the edge folders move back (this applies only to folder version without positioning pin).

In order to change the time period during which the edge folders move back press key 

and numeric keys **6** and **4** .

In the bottom line of the display the following appears:



along with the entered value in seconds.

Enter a new value by pressing numeric keys **0** to **9** and verify it by pressing the  key.

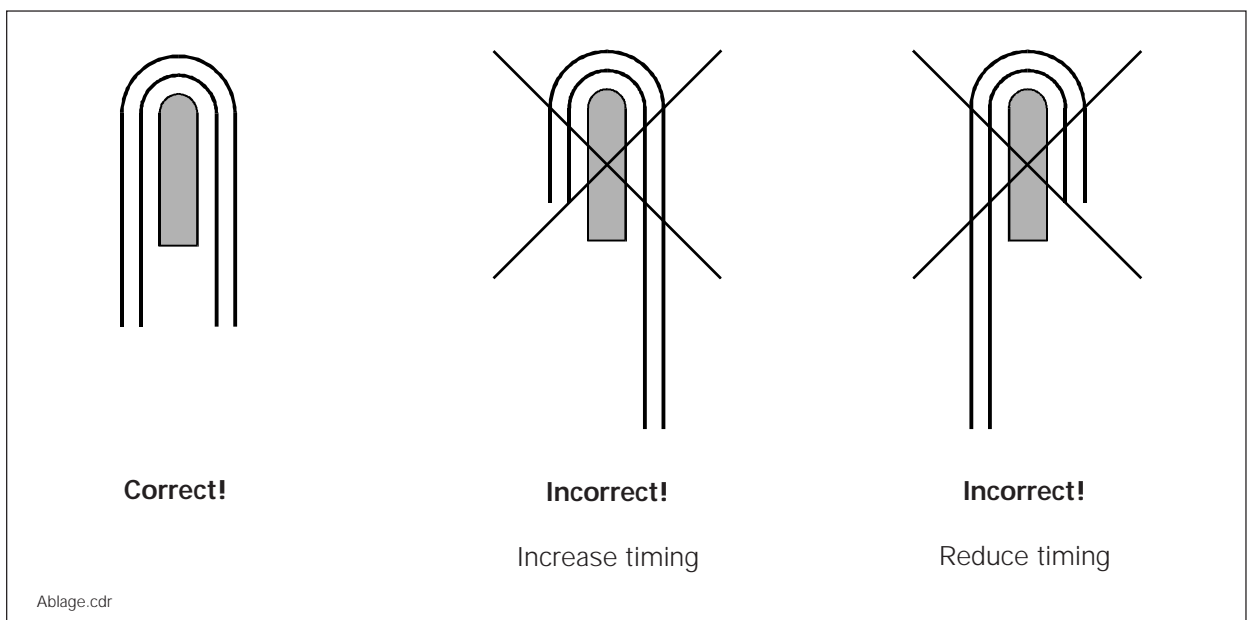

21.5 5 - TIMING F. EDGE FOLDERS BACKW.

The function "open folder" must be carried out only when all edge folders are positioned in their back end position.

In order to change the time period during which the function "open folder" is carried out,

press key  and numeric keys **6** and **5** .

In the bottom line of the display the following appears:

 along with the entered value in seconds.

Enter a new value by pressing numeric keys **0** to **9** and verify it by pressing the  key.

21.6 6 - TIMING FOR TRANSFER FORWARD

The jig feed from the folding to the sewing station must be carried out not until the pocket plate has moved out of the jig range.

In order to change the time period during which the function "transfer forwards" is carried out,

press key  and numeric key **6** twice.

In the bottom line of the display the following appears:

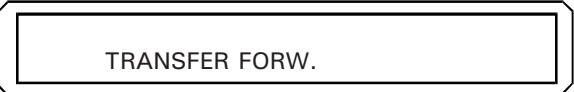
 along with the entered value in seconds.

Enter a new value by pressing numeric keys **0** to **9** and verify it by pressing the  key.

21.7 7 - TIMING FOR FOLDER DOWN

The function "folder down" must be carried out not until the folding head has reached its front end position.

In order to change the time period during which the function "folder down" is carried out,

press key  and numeric keys **6** and **7** .

In the bottom line of the display the following appears:

 along with the entered value in seconds.

Enter a new value by pressing numeric keys **0** to **9** and verify it by pressing the  key.

21.8 8 - TIMING FOR PULLER DOWN

With the puller feed enabled the pullers must rest on the workpiece as soon as the jig has moved out of the puller range.

In order to change the time period during which the function "puller down" is carried out,

press key  and numeric keys **6** and **8** .

In the bottom line of the display the following appears:

 along with the entered value in seconds.

Enter a new value by pressing numeric keys **0** to **9** and verify it by pressing the  key.

22 7 - SWITCH FUNCTIONS

22.1 1 - AIR BLAST SELECTION

1 - N. COOLING, TR. FOR. (Needle cooling during forward transfer)

In order to prevent the starting thread from being pushed underneath the presser foot during the workpiece transfer.

Press key  and numeric keys **7** **1** and then **1** again.

The air blast can be switched on with numeric key **1** and off with numeric key **0**.

2 - N. COOLING STACKER (Needle cooling whilst stacking)
- if desired -

Press key  and numeric keys **7** **1** and **2**.

The air blast can be switched on with numeric key **1** and off with numeric key **2**.

Air blast "workpiece transfer aid" (optional)

When processing large workpieces it is possible to work with the air blast "workpiece transfer aid" during the function procedures "jig feed forwards", "stacking", and "sewing" in order to prevent the workpieces from jamming.

3 - FAB. FEED, TR. FORW. (Air blast whilst "forward transfer")

Press key  and numeric keys **7** **1** and **3**.

The air blast can be switched on with numeric key **1** and off with numeric key **0**.

4 - FAB. FEED STACKER (Air blast whilst "stacking")

Press key  and numeric keys **7** **1** and **4**.

The air blast can be switched on with numeric key **1** and off with numeric key **0**.

5 - FAB. FEED SEWING (Air blast whilst sewing)

Press key  and numeric keys **7** **1** and **5**.

The air blast can be switched on with numeric key **1** and off with numeric key **0**.

22.2 2 - PULLER (Optional)

Press key  and numeric keys **7** and **2** .

The air blast can be switched on with numeric key **1** and off with numeric key **0** .

22.3 3 - POSITIONING PIN

(no setting required)

22.4 4 - THREAD MONITOR

Press key  and numeric keys **7** and **4** .

The air blast can be switched on with numeric key **1** and off with numeric key **0** .
(Mainly used for checks that are carried out by the mechanic.)

22.5 5 - BOBBIN MONITOR

Press key  and numeric keys **7** and **5** .

The bobbin thread monitor can be switched on with numeric key **1** and off with numeric key **0** .

22.6 6 - BOBBIN SENSOR

(Function is not available yet; must be switched off in the control, otherwise error message).

22.7 7 - PROG. CHANGE A - B

Automatic change between two entered programs.

Press key  once and numeric key **7** twice.

The automatic program change can be switched on with numeric key **0** and off with numeric key **1** .

22.8 8 - PLAIN FABRIC

When processing unicoloured material the function of the foot switch is not necessary.

Press key  and numeric keys **7** and **8** .

This altered function procedure can be switched on with numeric key **0** and off with numeric key **1** .

22.9 9 - INTERIM STOP

In "AUTOMATIC" mode the function effects a program stop after the conclusion of the folding procedure for checking purposes and for positioning a label.
The program can be continued by pressing the two start buttons on the loading station.

Press key  and numeric keys **7** and **9** .

The intermediate stop can be switched off by pressing numeric key **0** and on by pressing numeric key **1** .

22.10 0 - FURTHER FUNCTIONS

1 - AUTO HEAD LIFT (Lifting the head automatically for bobbin change)

Press key  and numeric keys **7** **0** and **1** .

The function can be switched off by pressing numeric key **0** and on by pressing numeric key **1** .

2 - LABEL FEEDER - Automatic label feed- (optional)

Press key  and numeric keys **7** **0** and **2** .

The label feed can be switched off by pressing numeric key **0** and on by pressing numeric key **1** .

3 - LABEL ALTERATION - Automatic label feed- after every other folding procedure (optional)

Press key  and numeric keys **7** **0** and **3** .

The alternating label feed can be switched off by pressing numeric key **0** and on by pressing numeric key **1** .

23

8 - ENTER FIXED PROGRAM NUMBERS

23.1

1 - FIXED PROG. A

23.1

2 - FIXED PROG. B

Fixed program "A" can be selected with key  and numeric keys **8** and **1** ;

fixed program "B" with numeric keys **8** and **2** respectively.

A program number can be assigned to each selected fixed program.

24 Recalling the service functions

(Applies only to the mechanic; for a detailed description see the service manual for the control)

In the basic state of the service all service functions can be displayed by means of the



key.

Switch on the machine.

Press key



:

Display:



By pressing the



key repeatedly the service functions are displayed.

- 1 - SET/RESET OF OUTPUTS
- 2 - STEPPING MOTOR (X-AXIS)
- 3 - STEPPING MOTOR (Y-AXIS)
- 4 - SEWING MOTOR
- 5 - THREAD TRIMMING SEQUENCE
- 6 - DISPLAY OF INPUTS

25 Programming the function sequence

Pre-select the function sequence according to the material to be processed (unicoloured, striped or checked fabric) following the indications given in section 22.8.

If two alternating seam programs are to be used, enter function "program change A-B" according to section 22.7 and assign a program number to each fixed program.

To this end press key



and numeric keys



:

- Program A is enabled.

Enter a program number with numeric keys



to



and verify it by pressing the



key.

Press key



and numeric keys



:

- Program B is enabled.

Enter a program number with numeric keys



to



and verify it by pressing the



key.

Pre-select the first program to be worked with by pressing key



or key



.

26 Inserting the workpiece

- .1 Cuttings on which the position of the pockets is marked are positioned according to the light marks sent out by the marking lamp (no standard equipment).
- .2 With unmarked cuttings mark the position of the various cuttings on the loading plate.
- .3 Insert cutting into folding station and position it.
- .4 Position pocket cutting on pocket plate 1 (fig. 1), push it underneath leaf springs 2 until it is in contact with stops 3 and align its sides with the sides of the pocket plate.
- .5 When processing checked or striped fabrics and with the corresponding programming (see section 22.8) actuate foot switch 4 (fig. 2):
 - Pocket plate moves down.
- .6 In order to align the pattern of the cutting with the one of the pocket actuate foot switch and hold it down:
 - Pocket plate is lifted.

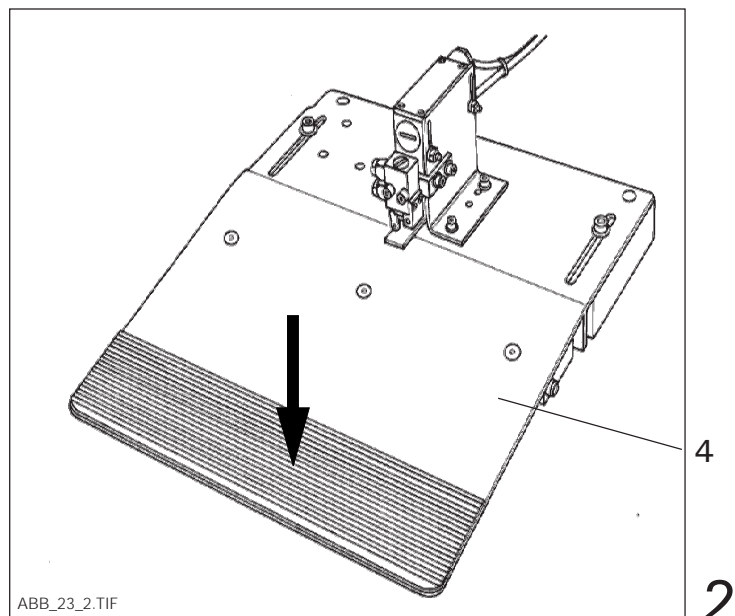
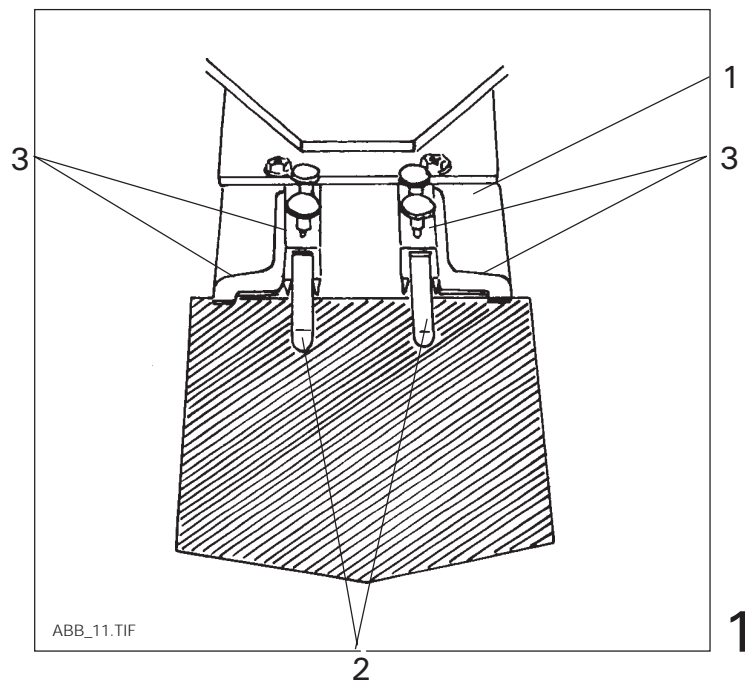

27 Sewing



The program must only be started when the carriage cover of the X-Y control is closed and the safety bar on the machine front is swung away from the machine. Keep your hands off the folder and the movement range of the sewing jig when a program is in operation: Danger of injury!

Insert and align workpiece (see section 26).

27.1 "MANUAL" mode

Press both start buttons at the same time:
- Pocket plate down*, folder forwards.

Cycle through the program sequence by pressing key  repeatedly:

- Folder and table top down
- Folder on and off
- Folder and table open
- Sewing jig to folding station, stacker enabled
- Sewing jig down
- Pocket plate back
- Sewing jig to sewing station

Press key :

- Sewing on.

* not required for the processing of checked and striped fabrics and the respective programming (see section 22.8).

27.2 "AUTOMATIC" mode

Press keys  and :

- Machine switches to automatic operation.

Press both start buttons 1 (fig. 1) at the same time:
- the whole working procedure is carried out automatically.

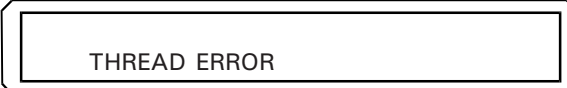

28 Disturbances

In the case of a thread breakage the following message is displayed:

Display: 

the machines cycles back automatically by 12 stitches and stands still.

Thread the needle thread according to section 13.

Press key  or  until the sewing jig has reached the position from where on the reworking is to be started.

Press key :

- the sewing operation is continued to the end of the program.

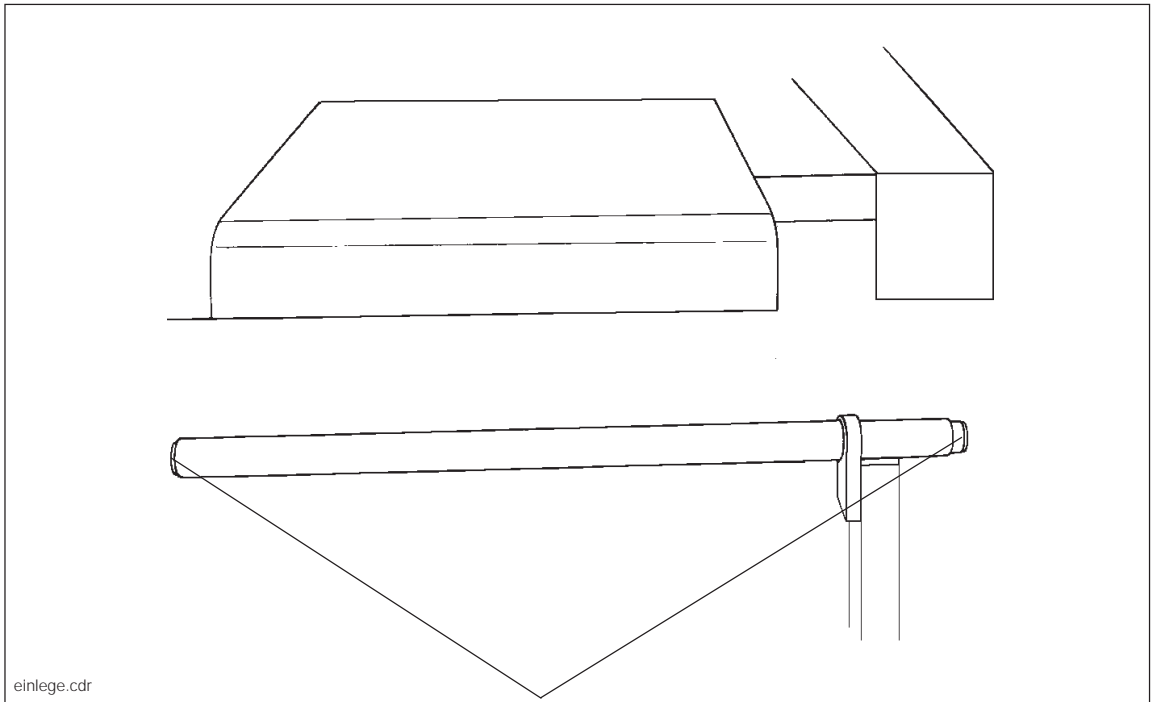

einlege.cdr

1

1

29 Maintenance and care

29.1 Oil sight glass of the sewing machine

Consider the max. and min. oil levels.

Hook lubrication: If necessary, top up (hole 1, fig. 1 or 2) oil (see section 29.6 "Recommended lubricants").

Zigzag drive: If necessary, top up oil (see section 29.6 "Recommended lubricants"), to this end unscrew screw 2 (fig. 2 or 3).

29.2 Lubrication of the carriage guides to the X-Y control of the sewing jig

In case of one shift a day grease the carriage guides twice a year, in case of two shifts a day grease them every three months (pin 3, fig. 5) and (pin 4, fig. 6). Use a grease gun. For grease type see section 29.6 "Recommended lubricants").

29.3 Cleaning the machine

- .1 The length of the intervals between the individual cleaning procedures depends on the following factors:

- one or more shifts a day
- dust emission of the material

Therefore optimum cleaning instructions can only be determined individually, i.e. in cooperation between the in-house maintenance staff and the authorized service personnel in consideration of the above mentioned factors and the respective operation manual.

- .2 In order to avoid disturbances in production we recommend the following cleaning procedures for factories that work with one shift a day:

- Clean the entire unit at least once a week.
- Clean hook area of the sewing machine several times a day.

3568-2/12

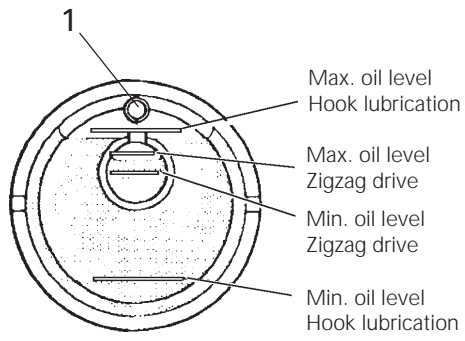

ABB_17.TIF

1

3568-12/12

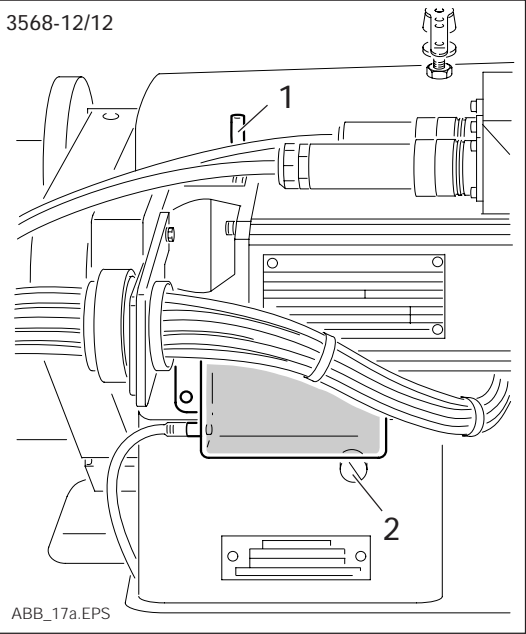

ABB_17a.EPS

2

3568-2/12

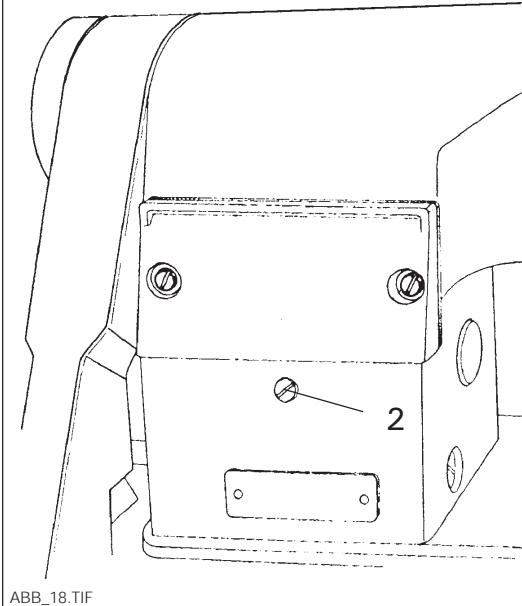

ABB_18.TIF

3

3568-12/12

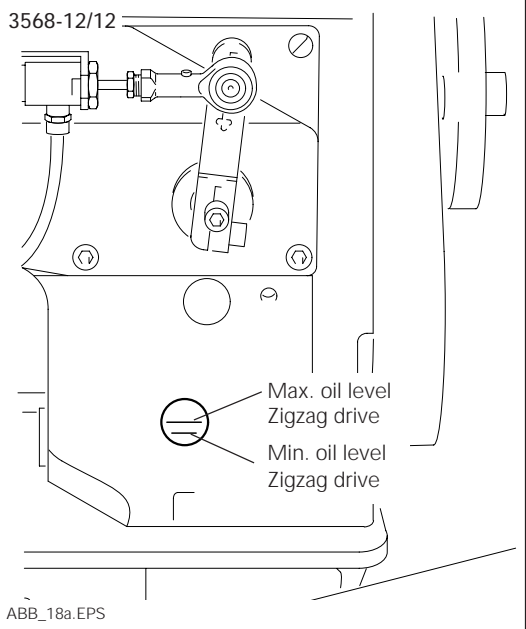

ABB_18a.EPS

4

3568-2/12
3568-12/12

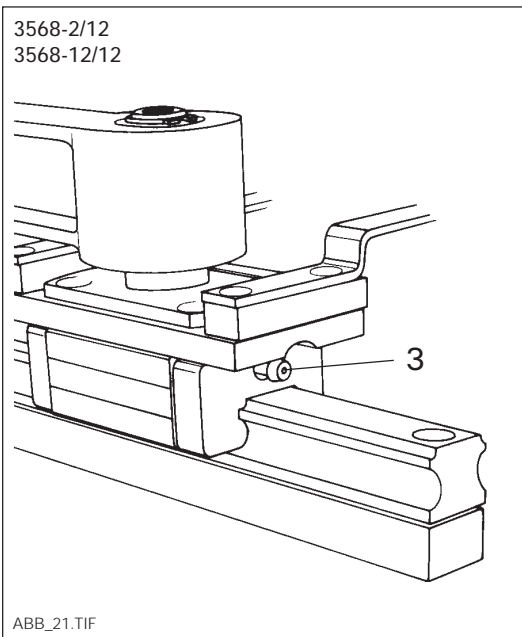

ABB_21.TIF

5

3568-2/12
3568-12/12

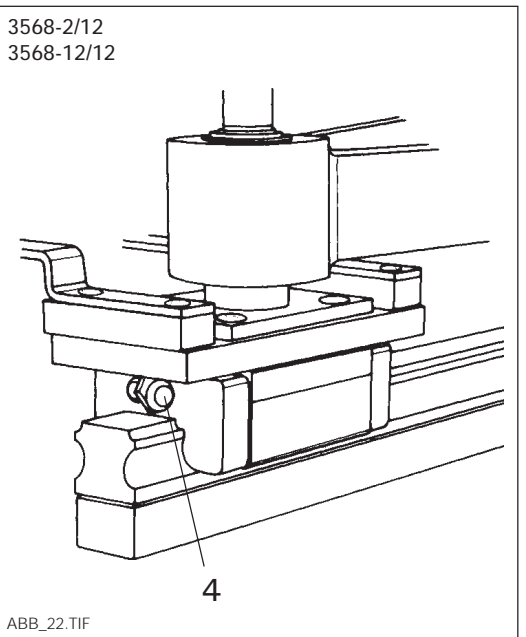

ABB_22.TIF

6

47

29.4 Air filter/lubricator (fig. 7)

.1 Water trap

For maximum water level see fig. 7.

- .1 Drain bowl 5 daily.

.2 Air filter

Note: Clean filter, if working pressure of 6 bar is no longer reached.

- .1 Disconnect compressed air.
- .2 Unscrew bowl 5.
- .3 Remove washer 7.
- .4 Remove filter 8.
- .5 Clean filter and bowl with **petrol**.
- .6 Blow out filter **from inside to outside** with compressed air.
- .7 When re-assembling, check for correct seat of seal.
- .8 Connect compressed air.

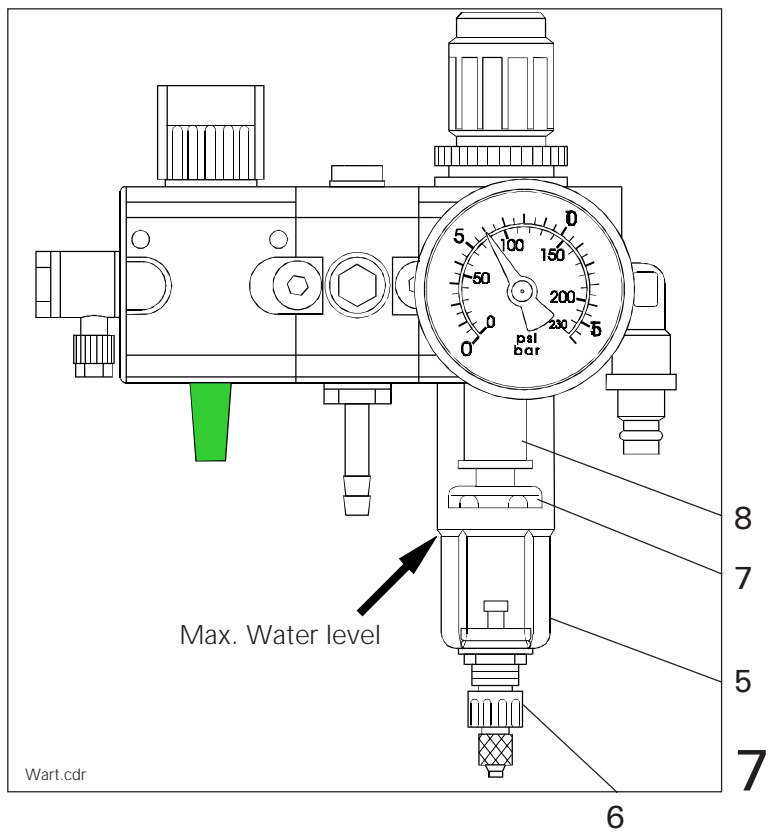

29.5 Cleaning the blower air filter

Requirement: Have filter 9 (fig. 8) and filter 10 (fig. 9) in the control box cleaned by the mechanic in intervals that depend on the pollution level of the air.

- .1 Remove cover 11 (fig. 8) and filter 9 and blow out with compressed air.
- .2 Then insert the filter and re-fit cover.
- .3 Open control box.



To this end it is vital to disconnect the mains plug.

- .4 Push lock 12 in and open flap 13.
- .5 Take out filter 10 and blow it out with compressed air.
- .6 Then re-fit filter and close flap 13.
- .7 We recommend to make a record of every air filter cleaning in the maintenance table on the inside of the control box door.

29.6 Recommended lubricants

- .1 Sewing machine

Pfaff oil, part no. 280-1-120-144, or oil with a mean viscosity of 22.0 mm²/s at 40°C and a density of 0.865 g/cm³.



The oils that are used must not or only to a small extent cause shrinkage or swelling of the sealing compounds at any operation condition.

- .2 Carriage guide to the X-Y control of the sewing jig

Lithium soap grease, Molykote BR 2 plus (part no. 280-1-120-207 or a similar all-purpose high-performance grease with a worked penetration of 265 to 295 and a drip-point at 185°C.

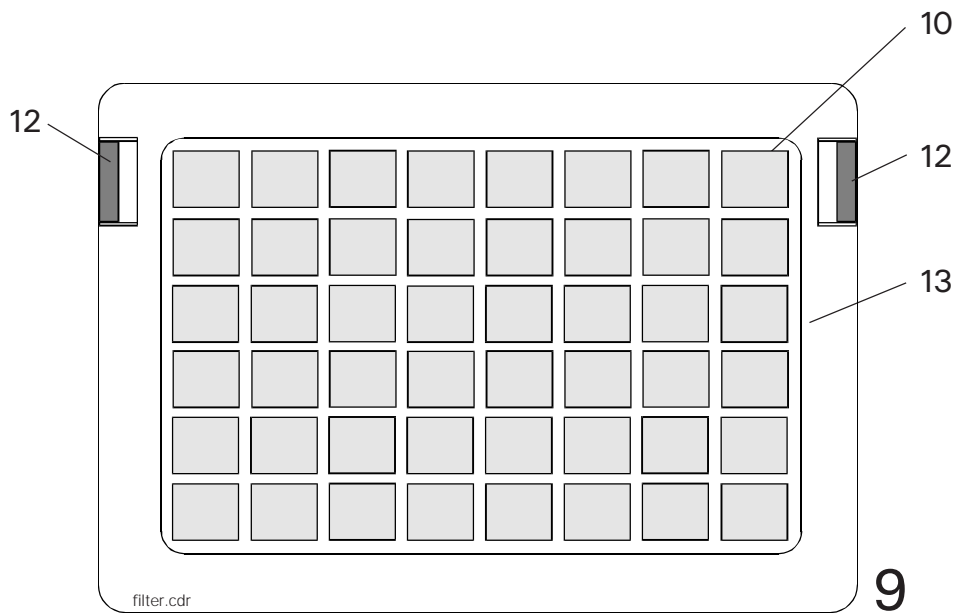
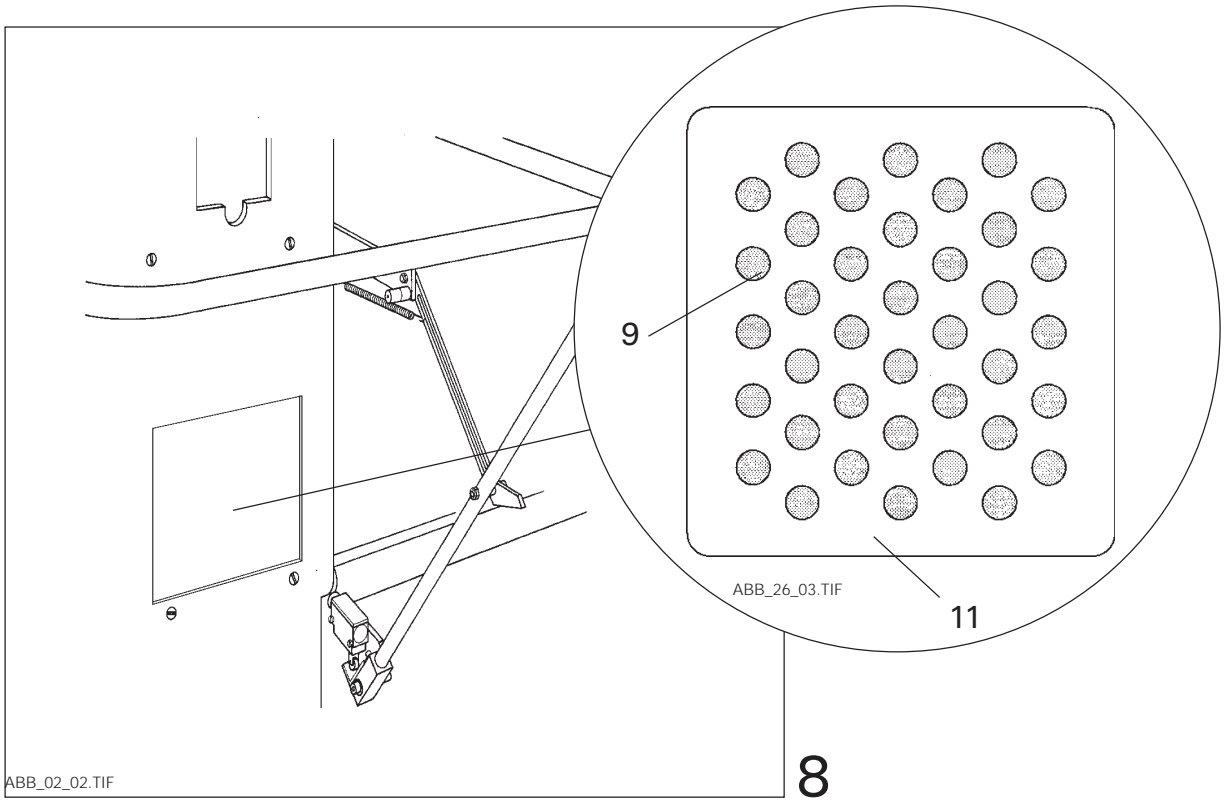

PFAFF

G.M. PFAFF
Aktiengesellschaft

Postfach 3020
D-67653 Kaiserslautern

Königstr. 154
D-67655 Kaiserslautern

Telefon: (0631) 200-0
Telefax: (0631) 172 02
Telex: 45753 PFAFF D

Gedruckt in der BRD
Printed in Germany
Imprimé en R.F.A.
Impreso en la R.F.A.
Stampato in R.F.G.
отпечатано ФРГ