

# PFAFF

## 3568-12/22

Instruction manual

At the time of printing, all information and illustrations contained in this document were up to date.

Subject to alteration!

The reprinting, copying or translation of PFAFF Instruction Manuals, whether in whole or in part, is only permitted with our previous authorization and with written reference to the source.

**G.M. PFAFF**  
**Aktiengesellschaft**

Postfach 3020  
D-67653 Kaiserslautern  
Königstr. 154  
D-67655 Kaiserslautern

Editing / Illustrations  
**HAAS-Publikationen GmbH**  
D-53840 Troisdorf

		Chapter - Page
	Contents .....	Chapter - Page
<b>1</b>	<b>Safety .....</b>	<b>1 - 1</b>
1.01	Directives .....	1 - 1
1.02	General notes on safety .....	1 - 1
1.03	Safety symbols .....	1 - 2
1.04	Important points for the user .....	1 - 3
1.05	Operating and specialist personnel .....	1 - 3
1.05.01	Operating personnel .....	1 - 3
1.05.02	Specialist personnel .....	1 - 4
1.06	Danger .....	1 - 5
<b>2</b>	<b>Proper use .....</b>	<b>2 - 1</b>
<b>3</b>	<b>Specifications .....</b>	<b>3 - 1</b>
<b>4</b>	<b>Disposal of the machine .....</b>	<b>4 - 1</b>
<b>5</b>	<b>Testing according to EN 60204-3-1 .....</b>	<b>5 - 1</b>
<b>6</b>	<b>Transport packaging and storage .....</b>	<b>6 - 1</b>
6.01	Transport to the customer's premises .....	6 - 1
6.02	Transport within the customer's premises .....	6 - 1
6.03	Disposal of the packaging .....	6 - 1
6.04	Storage .....	6 - 1
<b>7</b>	<b>Explanation of the symbols .....</b>	<b>7 - 1</b>
<b>8</b>	<b>Controls .....</b>	<b>8 - 1</b>
8.01	On/off switch .....	8 - 1
8.02	EMERGENCY OFF switch .....	8 - 1
8.03	Jig changeover control .....	8 - 2
8.04	Table control .....	8 - 2
8.05	Foot switch .....	8 - 3
8.06	Start controls .....	8 - 4
8.07	Control panel on the sewing station .....	8 - 5
8.07.01	Display .....	8 - 5
8.07.02	Operation mode keys .....	8 - 6
8.07.03	Program station keys .....	8 - 6
8.07.04	Red function keys .....	8 - 7
8.07.05	Green function keys .....	8 - 8
8.08	Control panel on the folder station .....	8 - 9
8.08.01	Operation mode keys .....	8 - 9
8.08.02	Station keys .....	8 - 9
8.08.03	Function keys .....	8 - 10

	Contents .....	Chapter - Page
<b>9</b>	<b>Mounting and commissioning the machine .....</b>	<b>9 - 1</b>
9.01	Mounting .....	9 - 1
9.02	Commissioning the machine .....	9 - 2
9.02.01	Turning the machine on/off .....	9 - 3
9.02.02	Adjusting zero point .....	9 - 4
<b>10</b>	<b>Preparation .....</b>	<b>10 - 1</b>
10.01	Inserting the needle .....	10 - 1
10.02	Winding the bobbin thread, adjusting the thread tension .....	10 - 2
10.03	Changing the bobbin .....	10 - 3
10.03.01	Bobbin change, bobbin case and bobbin thread tension .....	10 - 3
10.03.02	Changing the bobbin from the top in MANUAL mode .....	10 - 4
10.03.03	Changing the bobbin from the top in AUTOMATIC mode .....	10 - 5
10.04	Threading the needle thread .....	10 - 6
10.05	Program number selection .....	10 - 7
10.06	Automatic change in program station .....	10 - 8
10.07	Jig monitor (optional) .....	10 - 9
10.07.01	Activating jig monitor (menu) .....	10 - 9
10.07.02	Determining the jig code .....	10 - 10
10.08	Placement of the cuttings .....	10 - 11
<b>11</b>	<b>Programing and sewing .....</b>	<b>11 - 1</b>
11.01	Brief description of Input mode .....	11 - 1
11.01.01	Direct functions .....	11 - 1
11.01.02	Summary of the functions in the 1st menu level .....	11 - 1
11.01.03	Summary of the functions in the 2nd menu level .....	11 - 2
11.02	Description of the menu levels .....	11 - 3
11.02.01	1st menu level .....	11 - 3
11.02.02	Entering the 2nd menu level .....	11 - 3
11.02.03	2nd menu level .....	11 - 3
11.03	Examples for selecting functions .....	11 - 4
11.03.01	Selecting a direct function .....	11 - 4
11.03.02	Selecting a function from the 1st menu level .....	11 - 4
11.03.03	Selecting a subfunction from the 2nd menu level .....	11 - 5
11.04	Explanation of the menu functions .....	11 - 6
11.04.01	Functions in the 1st menu level .....	11 - 6
11.04.02	Functions in the 2nd menu level .....	11 - 8
11.05	Sewing .....	11 - 13
11.05.01	Sewing in the AUTOMATIC mode .....	11 - 13
11.05.02	Sewing in the MANUAL mode .....	11 - 14
11.05.03	Disturbances .....	11 - 15
<b>12</b>	<b>Care and maintenance .....</b>	<b>12 - 1</b>
12.01	Cleaning the machine .....	12 - 2
12.02	Lubricating the sewing head .....	12 - 3

	Chapter - Page
Contents .....	Chapter - Page
12.03 Lubricating the zigzag drive .....	12 - 4
12.04 Lubricating the carriage guides of the X/Y control .....	12 - 5
12.05 Lubricating jig changeover .....	12 - 6
12.06 Cleaning the blower air filter .....	12 - 7
12.07 Compressed air unit .....	12 - 8
12.07.01 Checking and regulating air compression .....	12 - 8
12.07.02 Cleaning the air filter .....	12 - 8
12.07.03 Checking and topping up the oil level .....	12 - 9
12.07.04 Emptying the water trap .....	12 - 10
12.07.05 Adjusting the drip feed rate on the oil vaporizer .....	12 - 10
12.07.06 Cleaning the vaporizer jet .....	12 - 10
<b>13 Adjustment .....</b>	<b>13 - 1</b>
13.01 Notes on adjustments .....	13 - 1
13.02 Tools, gauges and other accessories .....	13 - 1
13.03 Abbreviations .....	13 - 1
13.04 Removing/inserting sewing machine head .....	13 - 2
13.05 Checking and adjustment aids .....	13 - 3
13.06 Adjusting the sewing machine head .....	13 - 4
13.06.01 Counterweight .....	13 - 4
13.06.02 Centering the needle in the needle hole (in the direction of sewing) .....	13 - 5
13.06.03 Needle bar-parallel guide .....	13 - 6
13.06.04 Setting zero stitch .....	13 - 7
13.06.05 Zigzag stitch movement .....	13 - 8
13.06.06 Needle penetration symmetry .....	13 - 9
13.06.07 Centering the needle in the needle hole (across the direction of sewing) .....	13 - 10
13.06.08 Zigzag stitch width .....	13 - 11
13.06.09 Hook bearing .....	13 - 12
13.06.10 Hook lubrication .....	13 - 13
13.06.11 Gear box drive belt .....	13 - 14
13.06.12 Preadjusting the needle height .....	13 - 15
13.06.13 Needle bar rise, hook-to-needle clearance and bobbin case .....	13 - 16
13.06.14 Final adjustment of needle height .....	13 - 17
13.06.15 Bobbin case opener position .....	13 - 18
13.06.16 Bobbin case opener movement .....	13 - 19
13.06.17 Counter presser lifting stroke .....	13 - 20
13.06.18 Needle guard movement .....	13 - 21
13.06.19 Needle guard position .....	13 - 22
13.06.20 Counter presser height .....	13 - 23
13.06.21 Counter presser position .....	13 - 24
13.06.22 Presser .....	13 - 25
13.06.23 Needle thread tension release .....	13 - 26
13.06.24 Thread check spring .....	13 - 28
13.06.25 Thread puller .....	13 - 29
13.06.26 Bobbin winder .....	13 - 30

	Contents .....	Chapter - Page
13.06.27	Synchronizer .....	13 - 31
13.07	Adjusting the thread trimmer .....	13 - 32
13.07.01	Mounting/dismounting the control unit .....	13 - 32
13.07.02	Preadjusting the control cam .....	13 - 33
13.07.03	Roller lever .....	13 - 34
13.07.04	Latch .....	13 - 35
13.07.05	Engaging solenoid .....	13 - 36
13.07.06	Actuating lever .....	13 - 37
13.07.07	Engaging lever .....	13 - 38
13.07.08	Cutting test .....	13 - 39
13.07.09	Thread catcher position .....	13 - 40
13.07.10	Control cam (final adjustment) and catch spring .....	13 - 41
13.08	Adjusting the folding and feed devices .....	13 - 42
13.08.01	Adjusting the switch vanes on the X/Y control .....	13 - 42
13.08.02	Home position of the transport arm .....	13 - 43
13.08.03	Feed changeover .....	13 - 44
13.08.04	Sewing jig position at the sewing station .....	13 - 45
13.08.05	Aligning the sewing jig .....	13 - 46
13.08.06	Sewing jig position at the folding station (home position) .....	13 - 47
13.08.07	Proximity switch .....	13 - 48
13.08.08	Height of the loading plate .....	13 - 49
13.08.09	Height of pocket plate support .....	13 - 50
13.08.10	Basic dimensions of the folder .....	13 - 51
13.08.11	Height of the folder device .....	13 - 52
13.08.12	Position of pocket plate arm .....	13 - 53
13.08.13	Pocket plate position .....	13 - 54
13.08.14	Pocket plate height .....	13 - 55
13.08.15	Die .....	13 - 56
13.08.16	Position of folder plates .....	13 - 58
13.08.17	Actuating sequence of the folder plates .....	13 - 59
13.08.18	Position of corner folder .....	13 - 61
13.08.19	Roller lever valves .....	13 - 62
13.08.20	Parallelism of seam to pocket .....	13 - 63
13.08.21	Centering the pocket seam .....	13 - 64
13.08.22	Distance of seam to pocket .....	13 - 65
13.08.23	Seam backtack distance .....	13 - 66
13.09	Shaping folder plates .....	13 - 67
13.09.01	New installation / self-manufacture of folder plates .....	13 - 67
13.09.02	Slanting the lateral folder plates .....	13 - 68

## 1 Safety

### 1.01 Directives

This machine was built in accordance with the following European regulations:

- EC Machine Directive (89/392/EEC, 91/368/EEC, 93/44/EEC, 93/68/EEC)
- Safety of Appliances Law, Machine Ordinance - 9GSGV
- EC Directive „Electromagnetic Compatibility“ (89/336/EEC, 92/31/EEC, 93/68/EEC)
- EN 60204-1 Safety of Machines, Electrical Equipping of Industrial Machines: Part 3
- EN 292 Parts 1 and 2: 1991 Safety of Machines (Basic Terms)
- EN 294 Safety of Machines; safety clearance margins for avoiding dangerous situations for the upper limbs
- EN 349 Safety of Machines; minimum safety clearances for avoiding the crushing of body parts
- EN 418 Safety of Machines; devices for turning off the machine in emergencies
- DIN 45635 Measurement of noise levels

In addition to this Instruction Manual, also observe all generally accepted, statutory and other regulations and legal requirements - also those of the country in which the machine will be operated - and all valid environmental protection regulations!

Applicable local regulations of the social insurance society for occupational accidents or other supervisory organizations are to be strictly adhered to!

### 1.02 General notes on safety

- This machine must only be operated by adequately trained operators and only after having completely read and understood the Instruction Manual!
- All Notes on Safety and Instruction Manuals of the motor manufacturer are to be read before operating the machine!
- The Danger and Safety Instructions on the machine itself are to be followed!
- This machine must only be used for the purpose for which it is intended and must not be operated without its safety devices. All applicable safety regulations must be observed.
- When sewing parts (e.g. needle, presser foot, needle plate, feed dog or bobbin) are exchanged, when the machine is being threaded, when the machine is left unattended and during maintenance work, the machine is to be separated from the power supply by turning off the On/Off switch or removing the plug from the mains!
- Daily maintenance work must only be carried out by appropriately trained personnel!

- Repair work and special maintenance work must only be carried out by specialists or appropriately trained personnel!
- For maintenance and repair work on pneumatic devices, the machine must be separated from the source of pneumatic power! The only exceptions allowed are for adjustments and function testing by appropriately trained personnel!
- Work on electrical equipment must only be carried out by appropriately trained specialist personnel!
- Work is not permitted on parts and equipment which are connected to the power supply! Exceptions to this are contained in the regulations EN 50110.
- Modifications and alterations to the machine must only be carried out pursuant to all relevant safety regulations!
- Only spare parts which have been approved by us are to be used for repairs!  
We expressly point out that any replacement parts or accessories not supplied by us have not been tested and approved by us. The installation and/or use of any such products may result in negative changes to the constructional characteristics of the machine. We are not liable for any damage which may be caused by non-original parts.

## 1.03

### Safety symbols



Danger!  
Points to be observed.



Danger of injury to operating and specialist personnel!



## 1.04 Important points for the user

- This Instruction Manual is a component part of the machine and must be available to the operating personnel at all times.  
The Instruction Manual must be read before operating the machine for the first time.
- The operating and specialist personnel is to be instructed on the safety equipment of the machine and regarding safe work methods.
- It is the duty of the user to only operate the machine in perfect running order.
- It is the obligation of the user to ensure that none of the safety mechanisms are removed or deactivated.
- It is the obligation of the user to ensure that only authorized persons operate and work on the machine.

Further information can be obtained at the point of sale.

## 1.05 Operating and specialist personnel

### 1.05.01 Operating personnel

Operating personnel are persons responsible for the preparation, operating and cleaning of the machine as well as taking care of problems arising in the sewing area.

The operating personnel is obliged to observe the following points and must:

- always observe the Notes on safety in the Instruction Manual!
- never use any working methods which could reduce the level of safety in using the machine!
- not wear loosely fitting clothing or jewellery such as chains or rings!
- also ensure that only authorized persons have access to the potentially dangerous area around the machine!
- always immediately report to the user any changes in the machine which may reduce its level of safety!

## 1.05.02 Specialist personnel

Specialist personnel are persons who have completed expert education/training in the fields of electrics, electronics, pneumatics and mechanics. They are responsible for the lubrication, maintenance, repair and adjustment of the machine.

The specialist personnel is obliged to observe the following points and must:

- always observe the Notes on Safety in the Instruction Manual!
- switch off the On/Off switch before carrying out adjustments or repairs and ensure that it cannot be switched on again unintentionally!
- never work on parts and devices which are still connected to the power supply! The only exceptions to this directive are found in the regulations EN 50110.
- for maintenance and repair work on pneumatic devices, the machine must be separated from the source of pneumatic power! The only exceptions allowed are for function testing.
- replace the protective coverings and close the electrical control box after all repairs or maintenance work!

1.06

Danger



A working area of **1 meter** is to be kept free both in front of and behind the machine while it is in operation, so that it is always easily accessible.



Never reach into the sewing area while sewing!  
Danger of injury by the needle!



Never leave objects on the table or in the needle plate area while adjusting the machine settings! Objects can become trapped or be slung away!  
Danger of injury!

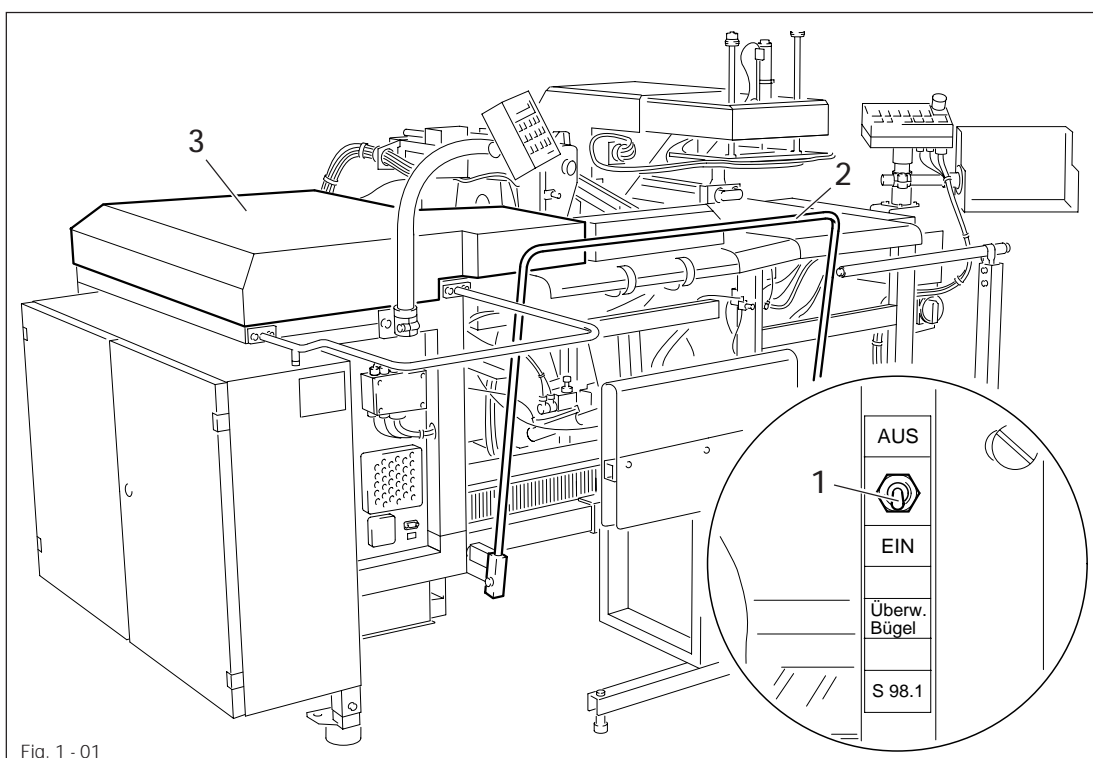

Fig. 1 - 01



Before operating the machine, make sure that safety switch **1** in the control box is switched on. Do not operate the machine under any circumstances if the safety switch **1** has been turned off! Danger of injury!



The machine must not be operated without safety bar **2**!  
Danger of injury by the transport arm when it is swinging back and forth!



The machine must only be operated with the cover **3** closed!  
Danger of injury by the moving parts of the XY control!



The machine must not be operated without the sewing head's protective devices such as the take-up lever guard and the belt guard!  
Danger of injury by the movement of the take-up lever or by the rotating V-belt!

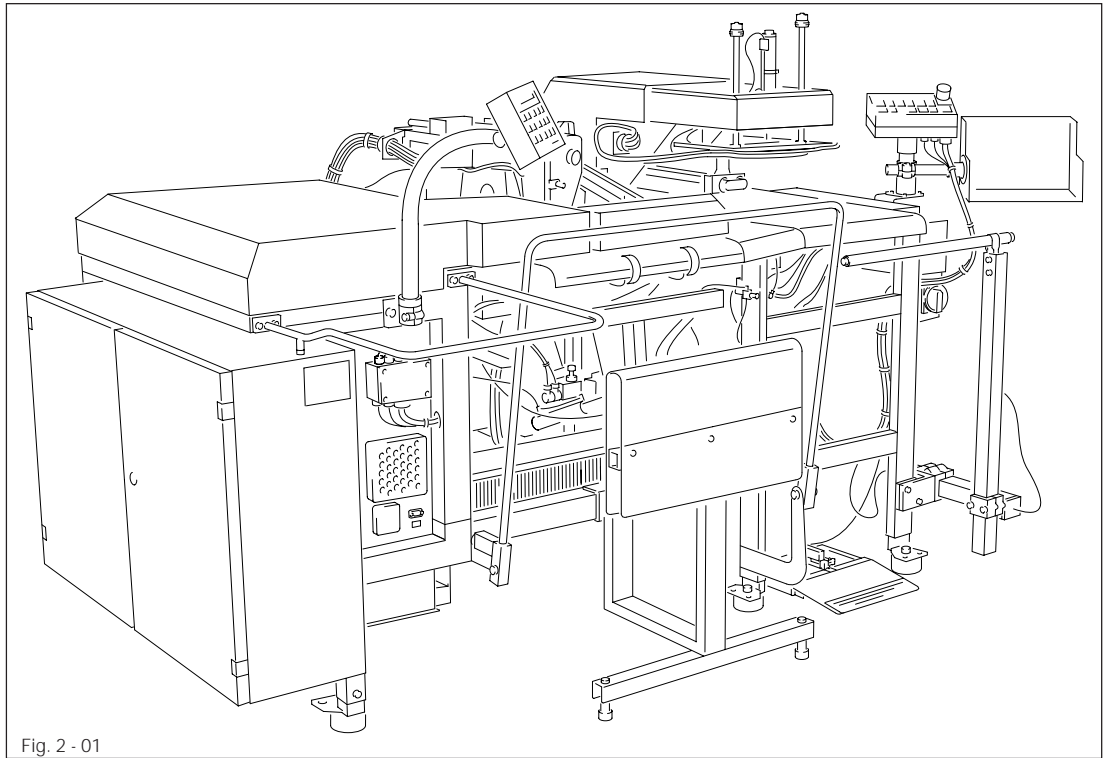

The PFAFF 3568-12/22 is used for folding and sewing on pockets on jeans, workwear, shirts and similar garments. Seams are created using the program functions.



Any and all uses of this machine which have not been approved of by the manufacturer are considered to be inappropriate! The manufacturer cannot be held liable for any damage caused by the inappropriate use of the machine! The appropriate use of the machine means that all operational, adjustment, maintenance and repair measures required by the manufacturer are to be observed!

### 3 Specifications

Sewing head: .....	PFAFF 918 -650/00 -900/51
Sewing speed: .....	max. 4100 spm <sup>-1</sup>
Stitch length: .....	max. 6 mm
Stitch type: .....	301 (lockstitch) 304 (zigzag lockstitch)
Needle system: .....	1955-07-MR5
Needle size: .....	110 - 140 Nm
Sewing motor: .....	AEG Permanent Magnet AC Servo-Motor
Motor speed: .....	max. 4500 rpm <sup>-1</sup>
Connection voltage: .....	230 V, 50 - 60 Hz AC
Power requirement: .....	approx. 1000 VA
Working air pressure: .....	min. 6 bar
Air consumption: .....	approx. 27 l / cycle
Working noise level:	
Emission at workplace at n = 4100 spm <sup>-1</sup> : .....	78 dB(A)
Dimensions of machine:	
Length: .....	approx. 2200 mm
Width: .....	approx. 1500 mm
Height: .....	approx. 1400 mm
Net weight: .....	approx. 653 kg
Gross weight: .....	approx. 840 kg

### 4 Disposal of the machine

- The proper disposal of the machine is the responsibility of the customer.
- The materials used are steel, aluminium, brass and various plastics. The electrical equipment consists of plastics and copper.
- The machine must be disposed of in accordance with applicable local environmental protection regulations.



Special care is to be taken that parts soiled by lubricants are separately disposed of in accordance with the applicable local environmental protection regulations!

5            **Testing according to EN 60204-3-1**

Prior to delivery, the machine was tested according to EN 60204-3-1 version 1/86.  
The following tests were carried out on the machine:

- proper connection of the protective conductor systems
  - a) visual check
  - b) testing connection of protective conductor to ensure that it is not defective
- insulation test
- voltage test
- performance test

### 6 Transport packaging and storage

#### 6.01 Transport to the customer's premises

Within Germany, machines are delivered without packaging.  
Machines for export are packaged.

#### 6.02 Transport within the customer's premises

The manufacturer bears no liability for transport within the customer's premises or to the location of use.

#### 6.03 Disposal of the packaging

The packaging of these machines consists of paper, cardboard and VCE fibre. The proper disposal of the packaging is the responsibility of the customer.

#### 6.04 Storage

The machine can be stored for up to 6 months if not in use. During this time it should be protected from dust and moisture.

For longer storage the individual parts of the machine, especially the moving parts, should be protected against corrosion, e.g. by a film of oil.



## 7 Explanation of the symbols

In this Instruction Manual, tasks to be carried out and important information are drawn to your attention by symbols.

The symbols have the following meanings:



Note, information



Cleaning, care



Lubrication

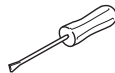

Servicing, repairing,  
adjustment, maintenance

## 8 Controls

### 8.01 On/off switch

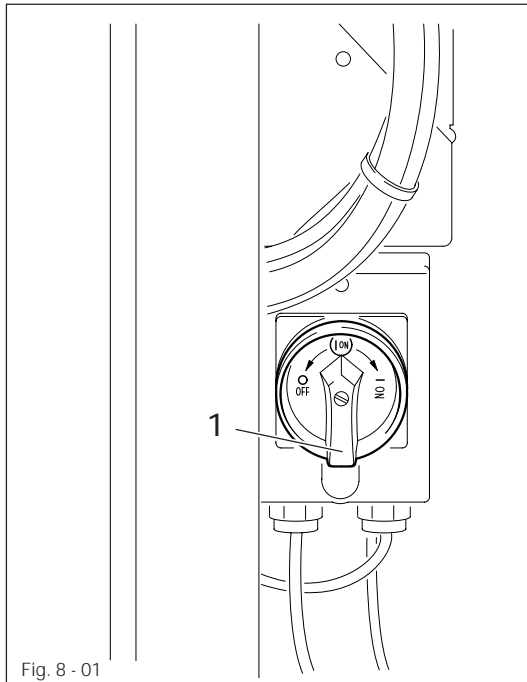

- By turning switch 1, the power supply to the machine is switched on or off.

### 8.02 EMERGENCY OFF switch

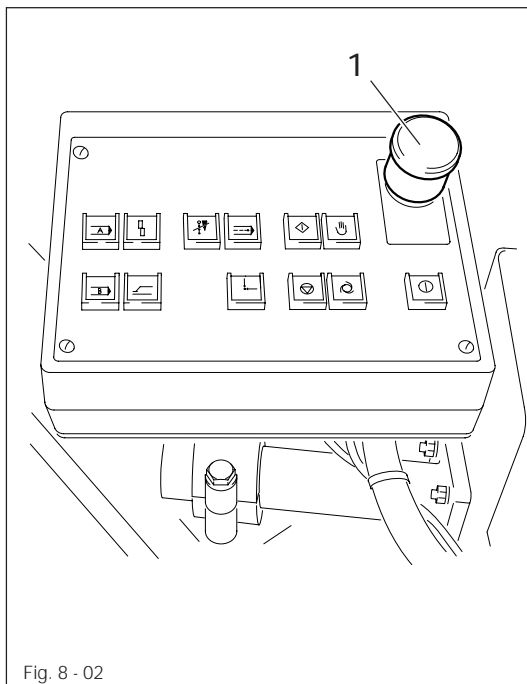

- By pressing the EMERGENCY OFF switch 1, the machine can be stopped in case of an emergency.
- Before the machine is turned back on, the EMERGENCY OFF switch 1 must be released by pulling it up.

8.03 Jig changeover control

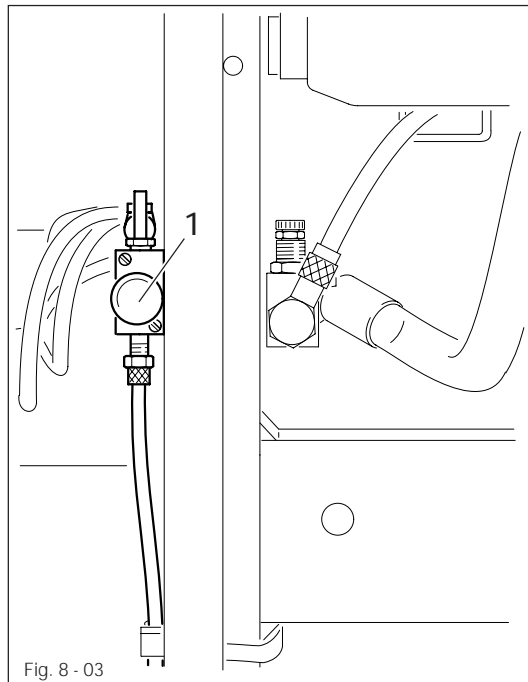

- When control 1 is activated, the sewing jig and the transport arm (jig changeover) are disconnected.

8.04 Table control

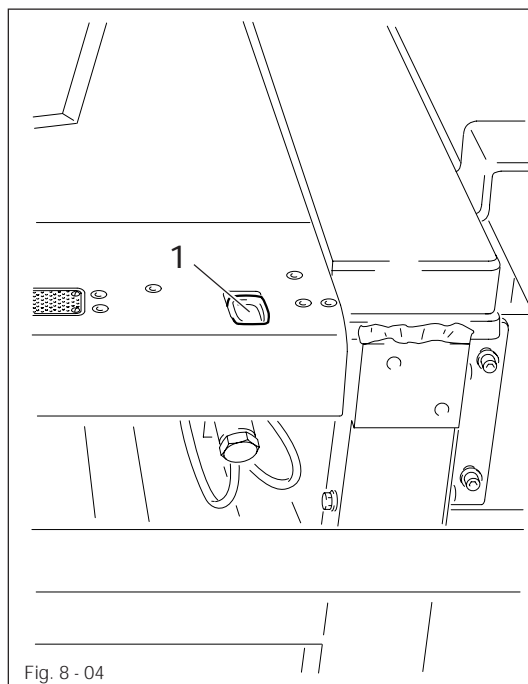

- When control 1 is activated, the retaining flap for the cuttings is raised so that the workpiece can be positioned.

## 8.05

## Foot switch

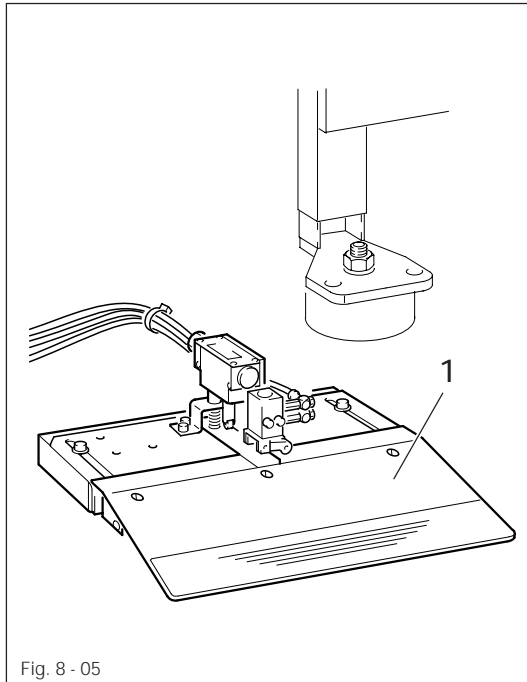

Fig. 8 - 05

- The function of the foot switch 1 can be adjusted to the various requirements for placing in the workpiece.
- The foot switch is adjusted via the menu.

By switching the functions HOME POSITION POCKET PLATE IN FRONT and PLAIN FABRIC on or off, the following menu combinations can be created:

Menu combinations	Foot switch functions
HOME POSITION POCKET PLATE IN FRONT on PLAIN FABRIC on	no function
HOME POSITION POCKET PLATE IN FRONT on PLAIN FABRIC off	Lower pocket plate. (When the foot switch is activated again, the pocket plate remains raised so that the material can be aligned.)
HOME POSITION POCKET PLATE IN FRONT off PLAIN FABRIC on	Move forward pocket plate.
HOME POSITION POCKET PLATE IN FRONT off PLAIN FABRIC off	1. Operation of switch: Move forward pocket plate. 2. Operation of switch: Lower pocket plate. (When the foot switch is activated again, the pocket plate remains raised so that the material can be aligned.)



Refer to **chapter 11 Programming and sewing** for information on selecting functions.

8.06 Start controls

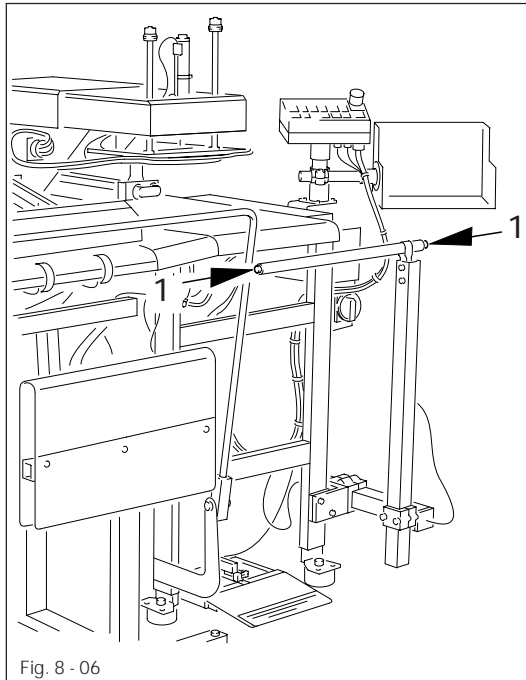

Fig. 8 - 06

- In **MANUAL** operation mode, when both start controls 1 are activated simultaneously a function is carried out according to the table below.
- In **AUTOMATIC** operation mode, when both start controls 1 are activated simultaneously the entire program sequence is started independent of the selected menu combination.
- The start controls 1 also are used to continue the program after the bobbin has been replaced.

By switching the functions HOME POSITION POCKET PLATE IN FRONT and PLAIN FABRIC on or off, the following menu combinations can be created:

Menu combinations	Start control functions
HOME POSITION POCKET PLATE IN FRONT on PLAIN FABRIC on	Lower pocket plate and move forward folder
HOME POSITION POCKET PLATE IN FRONT on PLAIN FABRIC off	Move forward folder
HOME POSITION POCKET PLATE IN FRONT off PLAIN FABRIC on	Lower pocket plate and move forward folder
HOME POSITION POCKET PLATE IN FRONT off PLAIN FABRIC off	Move forward folder



Refer to **chapter 11 Programming and sewing** for information on selecting functions.

## 8.07 Control panel on the sewing station

This control panel is used primarily for setting up the machine.

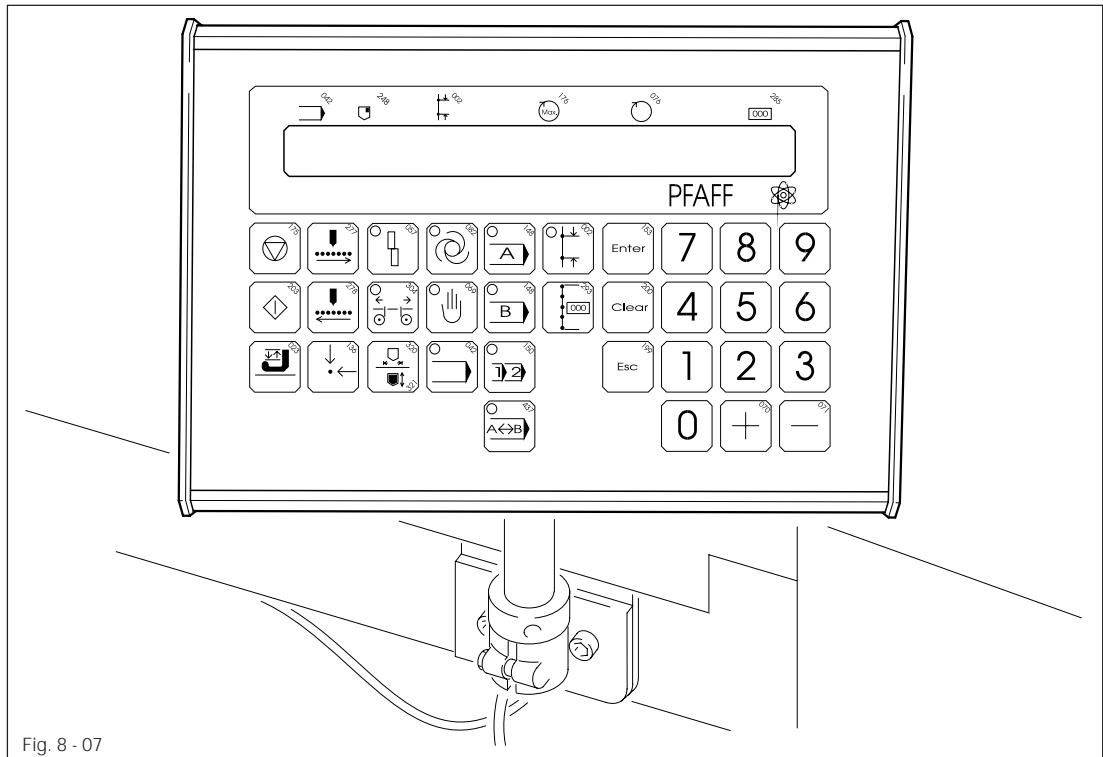

Fig. 8 - 07

### 8.07.01 Display

- The current value appears in the top line under the corresponding symbol.



Program number (0-99)



Jig code (option)



Stitch length (in mm)



Maximum speed (in min<sup>-1</sup>)



Actual speed (in min<sup>-1</sup>)



Counter

- Various texts (e.g. input prompt, error message, etc.) appear in the bottom line of the display. Next to the symbol "#" is the text number of the text displayed (the text number is used for unique assignment of the texts in the various languages).

8.07.02 Operation mode keys

The system has three operation modes.

The operation mode selected is indicated by the light diode of the corresponding key.



Operation mode **AUTOMATIC**



Operation mode **MANUAL**



Operation mode **INPUT**



For operation within the individual operation modes, only certain functions can be used depending on the mode.

8.07.03 Program station keys

These keys activate functions in all three operation modes: **AUTOMATIC**, **MANUAL** and **INPUT**.

Via the keys, you can choose between 2 programs directly (e.g. varying backtacking for left and right pockets). The activated program station is indicated by the light diode.



**Program station A**

To select program station A.



**Program station B**

To select program station B.

## 8.07.04 Red function keys

These keys only have functions in the operation modes **AUTOMATIC** and **MANUAL**.



### Program stop

Interrupt sewing program.



### Program start

Start sewing program.

Continue program following interruption.



### Presser/thread trapper

Raise or lower presser.

Open or close thread trapper.



### Seam pattern forwards

Sew seam pattern forwards step by step.

Combined with the **program start key**, the seam pattern sequence is carried out automatically.



### Seam pattern backwards

Sew seam pattern backwards step by step.

Combined with the **program start key**, the seam pattern sequence is carried out automatically.



### Home position

Bring X/Y carriage and sewing to start position.



### Reset key

Acknowledge error correction.



### Change bobbin

In home position:

Move transport arm to folder station and tilt sewing machine upward.

In seam program:

Move stacker forward or backward respectively.



### Transport arm/sewing jig

In sewing index (sewing jig linked to the sewing station):

Move transport arm to sewing or folder station.



In transport index (sewing jig linked to transport arm):

Raise or lower sewing jig.



8.07.05 Green function keys

These keys only have functions in the operation mode **INPUT**.



**Program selection**

When the function is activated (diode lit), a previously stored program can be selected via the **number keys** or the **plus/minus keys**.



**Automatic station change**

When the function is activated (diode lit), after every sewing operation there is an automatic change between program stations A and B.



**Stitch length change**

When the function is activated (diode lit), the value for the stitch length can be changed via the **number keys** or the **plus/minus keys**. The value entered must be confirmed with the **Enter key**.



**Reset stitch counter**

For resetting the bobbin thread stitch counter following an unplanned bobbin change.



**Enter key**

For confirming input values and dialogs (entry into functions).



**Clear key**

For resetting input values.



**Esc key**

For interrupting functions without assuming input values (return to previous menu level).



**Plus key**

For increasing the input values in increments, answering dialog questions with "yes" and for paging up in the menu mode.



**Minus key**

For decreasing the input values in increments, answering dialog questions with "no" and for paging down in the menu mode.

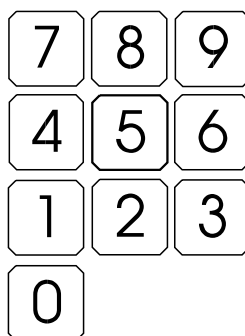

**Number keys**

For entering number values and direct selection of menu functions.

## 8.08 Control panel on the folder station

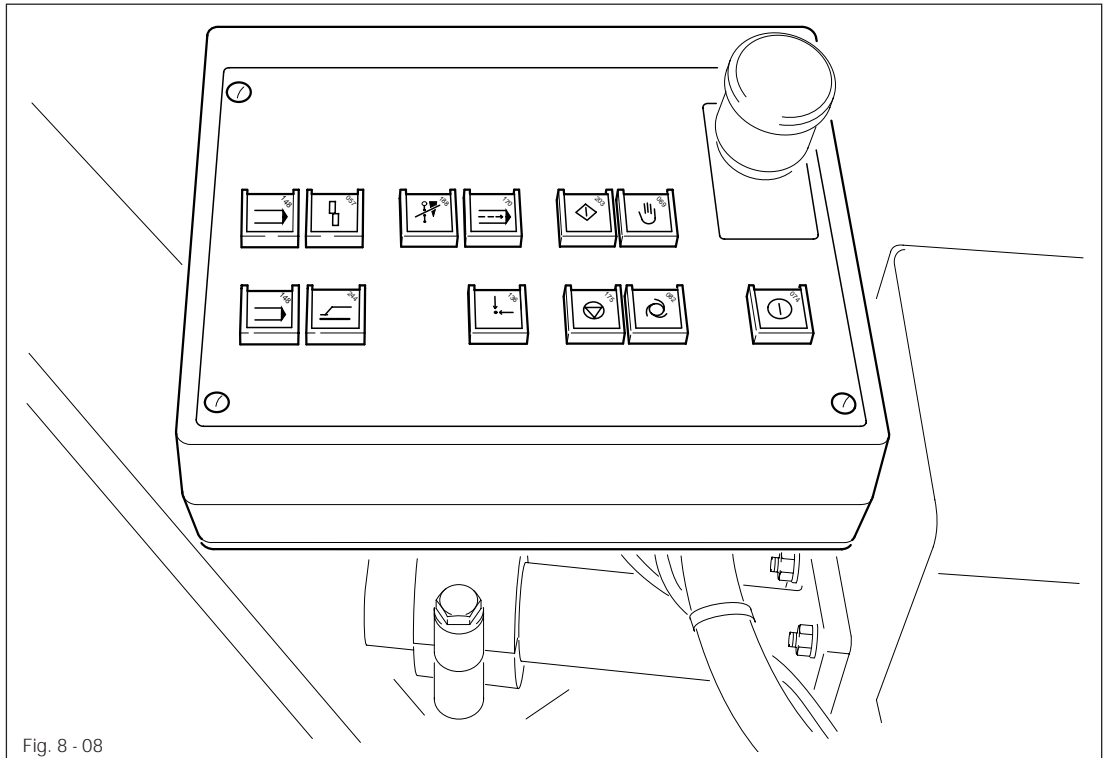

### 8.08.01 Operation mode keys

The keys have the same function as those on the control panel of the sewing station (refer to [chapter 8.07.02 Operation mode keys](#)).



Operation mode **AUTOMATIC**



Operation mode **MANUAL**

### 8.08.02 Station keys



**Program station A**  
Select program station A.



**Program station B**  
Select program station B.

8.08.03 Function keys



**Reset key**  
Acknowledges error correction.



**Label**  
Adds label (optional).



**Do not sew**  
All functions are carried out except sewing.



**Folder movement**  
Carries out folder functions step by step.  
(Single steps of the machine without sewing.)  
(Only in **MANUAL** operation mode.)



**Home position**  
Brings folder and transport arm into starting position.



**Program start**  
Starts sewing program.  
Continues program after an interruption.



**Program stop**  
Interrupts sewing program.



**Switch on key**  
Turns on the machine.

# Mounting and commissioning the machine

## 9 Mounting and commissioning the machine

After unpacking the machine, check it for any transport damage. In case of damage, inform the shipping company and the responsible PFAFF dealer.



The machine must only be mounted and commissioned by qualified personnel!  
All relevant safety regulations are to be observed!

### 9.01 Mounting

Suitable connections for supplying electricity and compressed air must be available at the machine's location (refer to **chapter 3 Specifications**).

The location where the machine is set up must have a flat, sturdy surface.

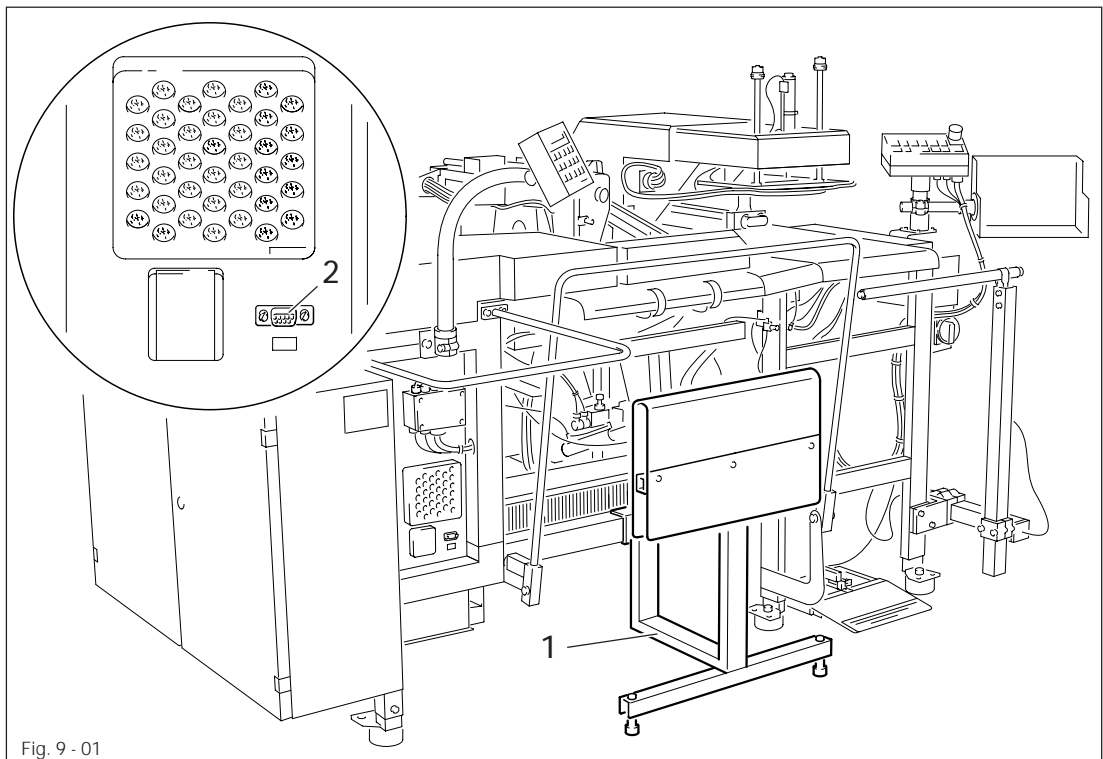

Fig. 9 - 01

- Lift the machine with a forklift from the shipping pallet.
- Screw the six enclosed rubber springs onto the legs.
- Set down the machine on the ground and make sure it is standing horizontally by pushing the legs.
- Attach stacker frame and align.
- Plug disk drive into socket 2.

## 9.02 Commissioning the machine

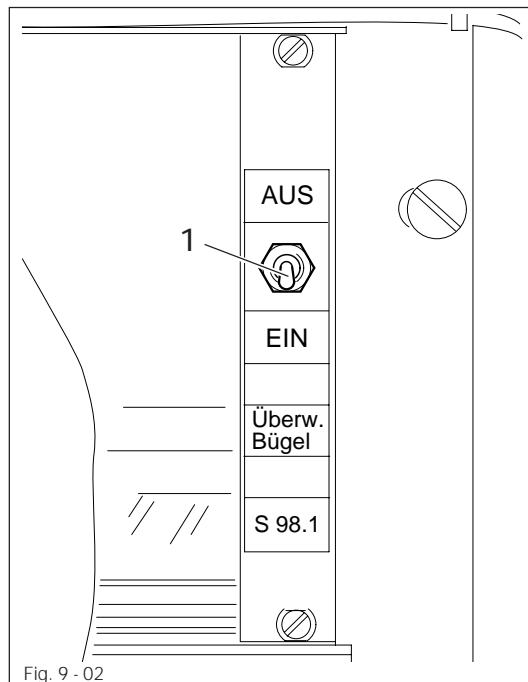

Fig. 9 - 02

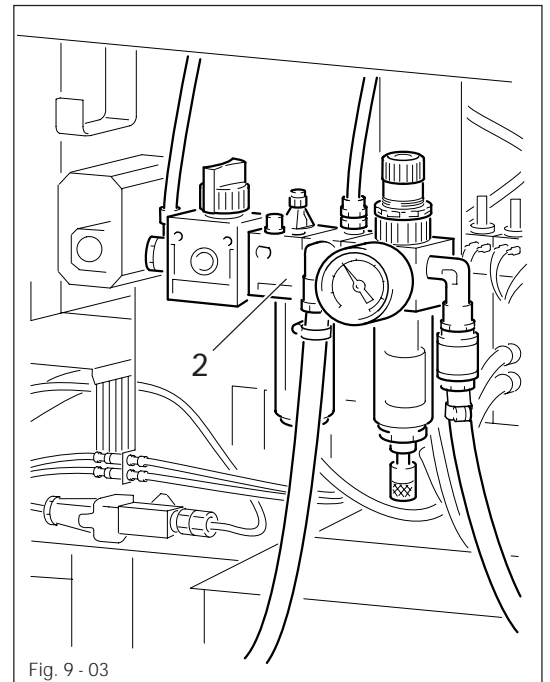

Fig. 9 - 03



The safety switch 1 in the control box must be turned on before commissioning the machine! The machine must not be operated when the safety switch 1 is turned off! Danger of injury!



The machine can be operated either with or without lubricated air. For operation without lubricated air, the oil bowl in the air lubricator 2 must remain empty.



Machines which have been operated once with lubricated air must always be supplied with lubricated air!

- Clean the machine thoroughly, checking the electrical cables and pneumatic connecting hoses for any damage.
- Oil machine and/or fill with oil (see **chapter 12 Care and maintenance**).
- Have specialists ensure that the machine's motor can be operated with the available electricity supply and that it is connected correctly to the power supply. If not, the machine **must not** be operated.
- Connect the machine to the compressed air system. The pressure gauge on the air lubricator 2 must indicate a pressure of 6 bar. If necessary, set the gauge to this value (see **chapter 12.07.01 Checking and regulating air compression**).

# Mounting and commissioning the machine

## 9.02.01 Turning the machine on/off

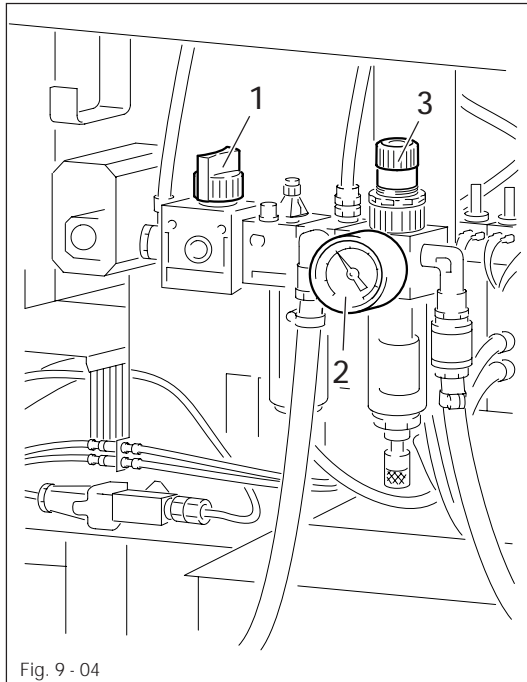

Fig. 9-04

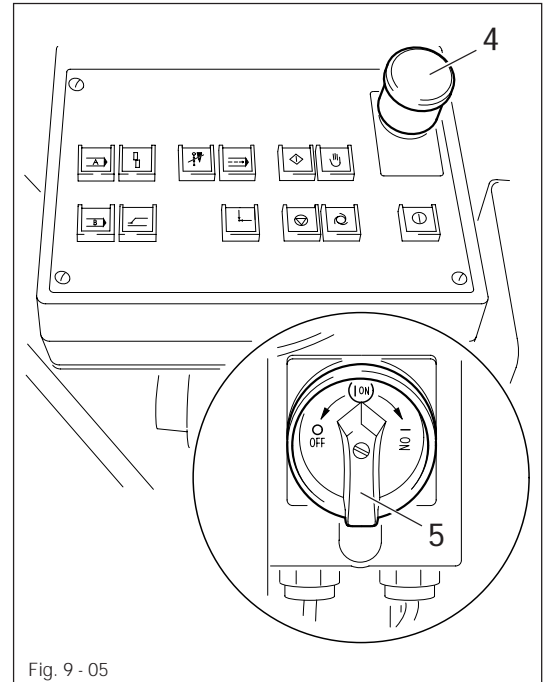

Fig. 9-05

- Open knob 1.
- Check air pressure on pressure gauge 2, and regulate air compression with adjusting knob 3, if necessary.
- If necessary, release EMERGENCY OFF switch 4 by pulling up on it.
- Turn master switch 5 to "ON".



- Press the **On key** on the control panel of the folder. The machine is now in the **INPUT** operation mode.



When the machine is commissioned, the zero point must first be checked and/or adjusted (see **chapter 9.02.02 Adjusting zero point**).

- To turn off the machine, turn master switch 5 to "OFF" and close knob 1.



In emergencies, the machine can be stopped immediately by pressing down the EMERGENCY OFF switch 4.

## 9.02.02 Adjusting zero point

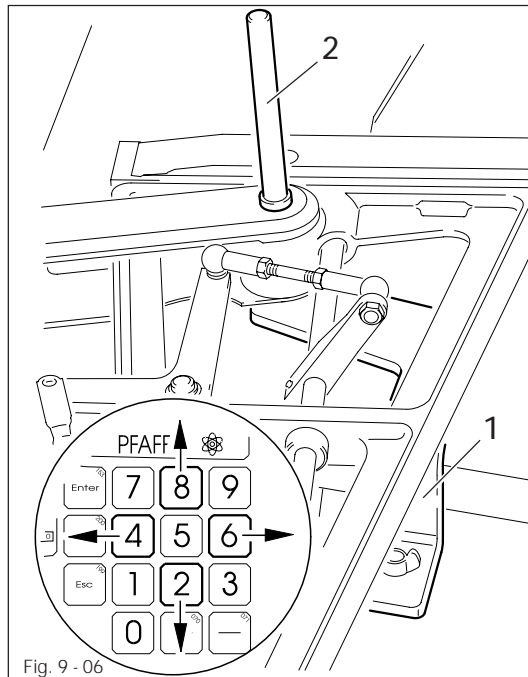

Fig. 9-06

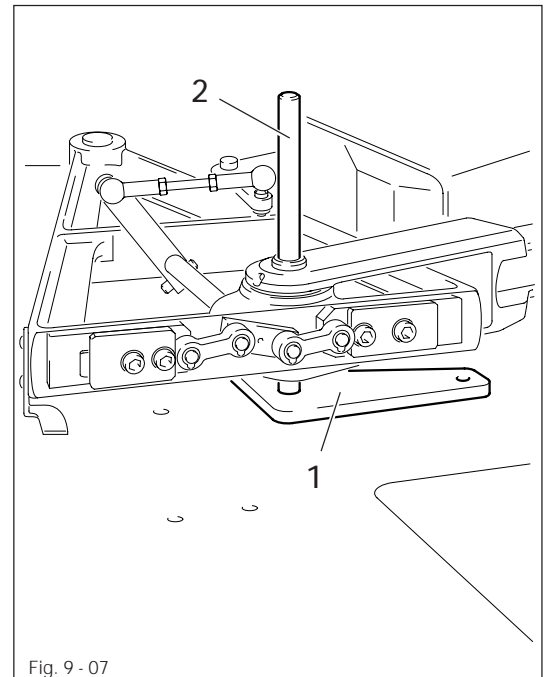

Fig. 9-07



It is necessary to adjust the zero point when the machine is commissioned and after replacing the CPU or one of the proximity switches of the X/Y control.



Only use the numbered zero-point gauge which belongs to the machine! The individual gauge vary from machine to machine.



- Select **INPUT** mode.

Display: "CHOOSE FUNCTION OR SCROLL #250"

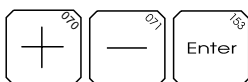

- Via the **plus/minus key**, select the **2nd menu** and confirm with **Enter**.

Display: "- 2. MENU #261"



- In the **2nd menu**, press number key "6" to select the **SERVICE** function.

Display: "SERVICE #800"



- Via the number key "5" select the **ADJUST ZERO POINT** function.

Display: "PRESS HOME KEY #007"



- Press **home key**.

Display: "ZERO POINT GAUGE INSERTED ? #867"

- Open cover of X/Y carriage control
- Insert zero point gauge **1** and screw on.



- Confirm with **Enter**.

# Mounting and commissioning the machine

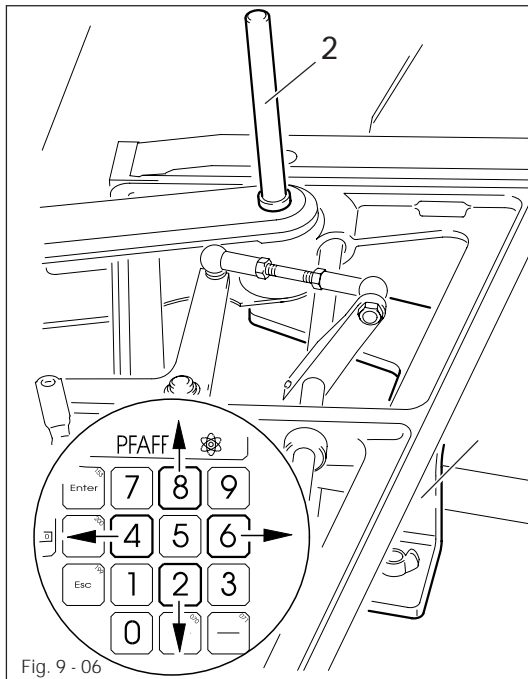

Fig. 9 - 06

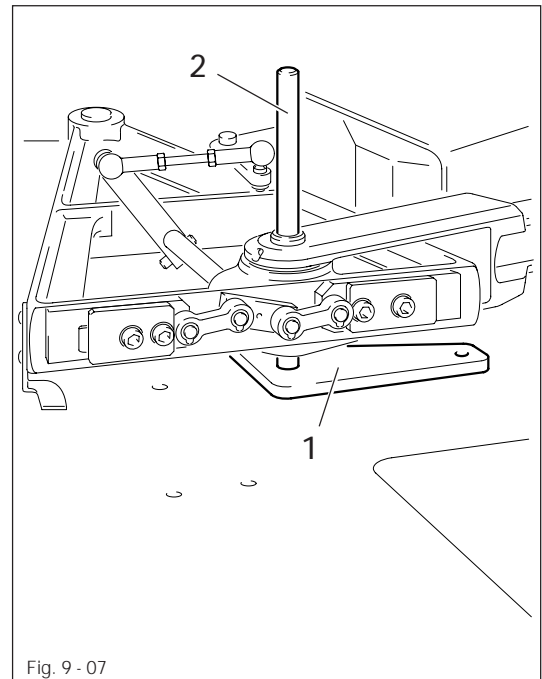
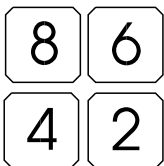

Fig. 9 - 07



- Insert adjustment pin 2 into the hole in the X/Y control. Move X/Y carriage with the number keys "4", "6", "2" and "8" in such a way that the end of adjustment pin 2 falls easily into the **back** hole of the zero point gauge 1. (see Fig. 9-06).

- Remove adjustment pin 2.



- Press **Enter**.

Display: "SERVICE

#800"



- Select **MANUAL** mode to bring the X/Y control to home position.



- Press **transport arm/needle** to swing the transport arm to the sewing station.



- Press **home position** key twice.

- Insert adjustment pin 2 into the hole in the X/Y control (see Fig. 9-07).

- The end of the adjustment pin 2 must now easily fall into the **front** hole of the zero point gauge 1. If this is not the case, the switch vanes of the X/Y carriage must be adjusted (see **chapter 13.08.01 Adjusting the switch vanes on the X/Y control**).

- Remove zero point jig 1.



10 Preparation



All regulations and instructions in this Instruction Manual are to be observed!  
Special attention is to be paid to the safety regulations!



All preparation work is only to be carried out by appropriately trained personnel.  
Make sure, in particular, that the safety switch in the control box is turned on.

10.01 Inserting the needle

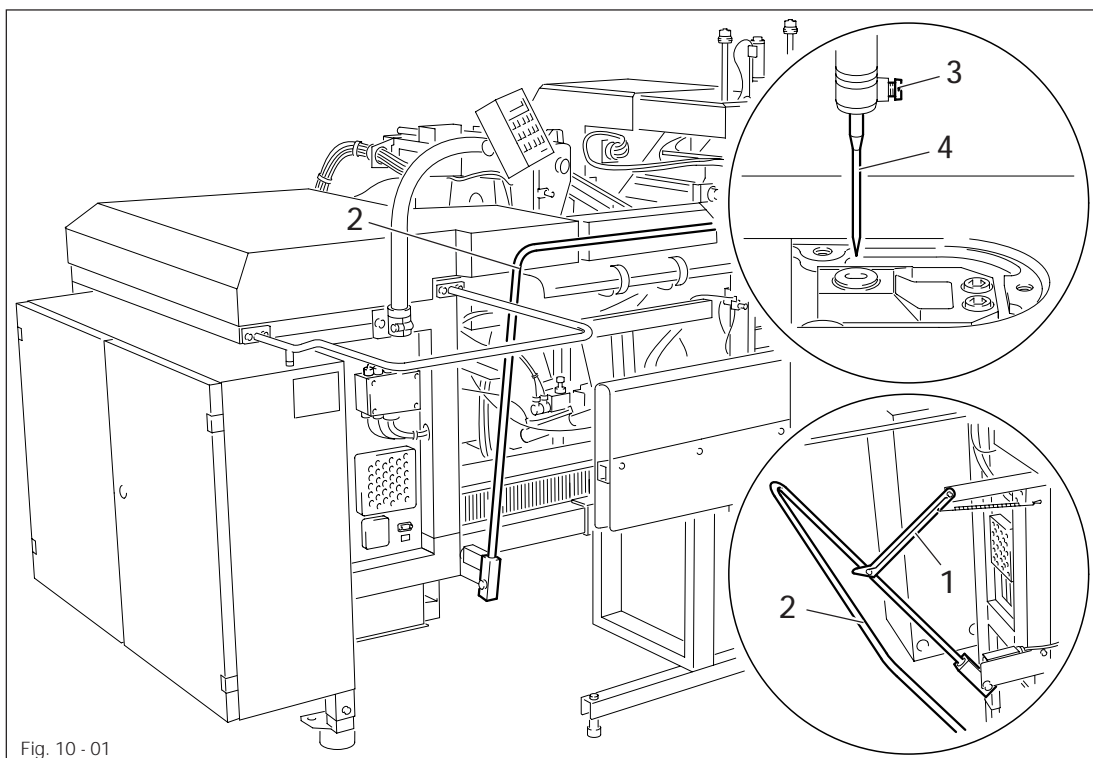

Fig. 10 - 01

- Lift ratchet lever 1 and swing in safety bar 2 until it is resting against the machine.



- Press seam pattern forwards key.



- Press transport arm/ sewing jig key.

- Loosen screw 3 and insert needle 4 until it stops in such a way that the long needle groove is pointing to the folder station.

- Tighten screw 3.



- Press transport arm/ sewing jig key.



- Press seam pattern backwards.

- Swing back safety bar 2 to its starting position.

## 10.02 Winding the bobbin thread, adjusting the thread tension

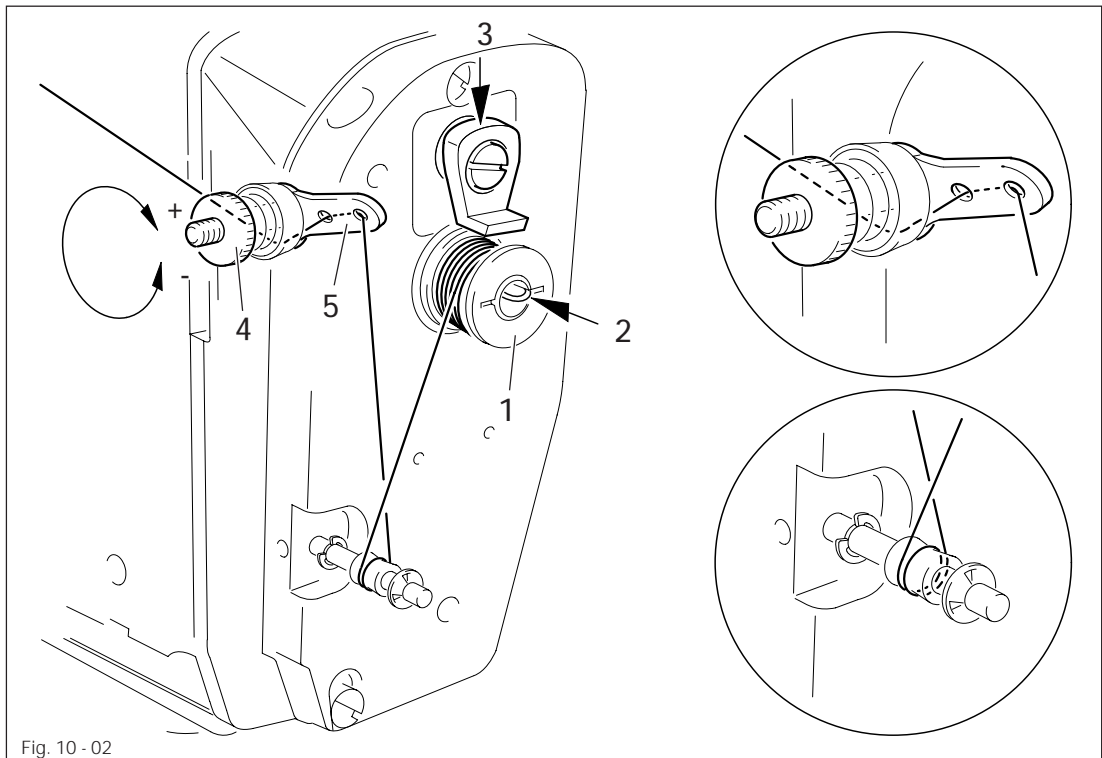

Fig. 10 - 02

- Place an empty bobbin 1 onto bobbin shaft 2.
- Thread the bobbin in accordance with Fig. 10-02 and wind it clockwise around bobbin 1 a few times.
- Switch on the bobbin winder while at the same time pressing bobbin winder spindle 2 and cam 3.



The bobbin fills up while you are sewing.

- If the bobbin 1 is not filled evenly, align thread guide 5 and adjust the bobbin thread tension with knurled screw 4.
- The bobbin winder stops automatically when bobbin 1 is full.

10.03 Changing the bobbin

10.03.01 Bobbin change, bobbin case and bobbin thread tension

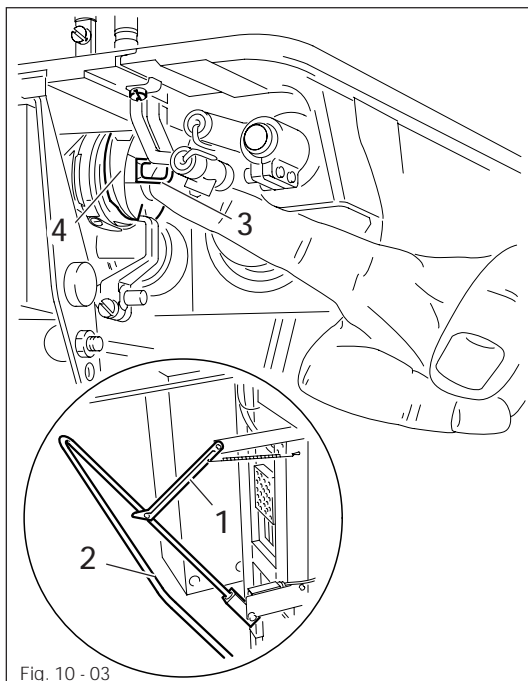

Fig. 10 - 03

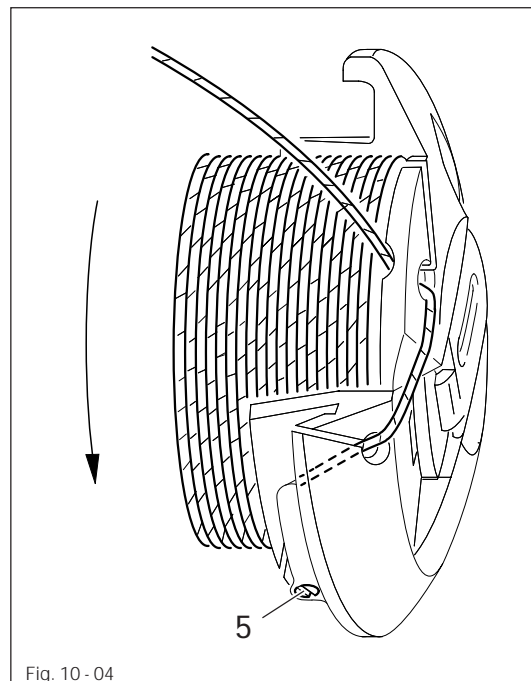

Fig. 10 - 04

- Lift ratchet lever 1 and swing in safety bar 2 until it rests against the machine.



- Press **change bobbin** key (stacker moves forward).

Remove bobbin case:

- Raise latch 3 and remove bobbin case 4.

Inserting bobbin in bobbin case:

- Insert the bobbin so that the bobbin turns in the direction of the arrow when the thread is pulled.
- Thread according to Fig. 10-04 and regulate the thread tension at screw 5.

Inserting bobbin case:

- Raise latch 3 and insert bobbin case 4 with the bobbin in the hook.
- Release latch 3 and press lightly on bobbin case 4 until it engages properly.



- Press **change bobbin** key.
- Swing back safety bar 2 to starting position.

## 10.03.02 Changing the bobbin from the top in MANUAL mode

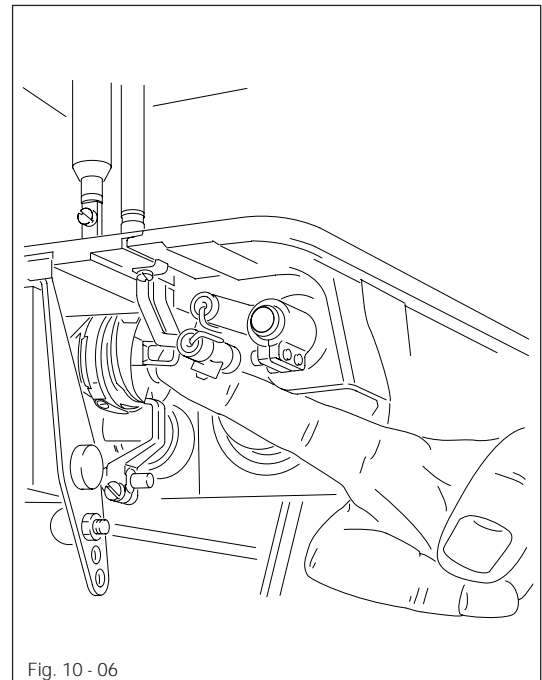
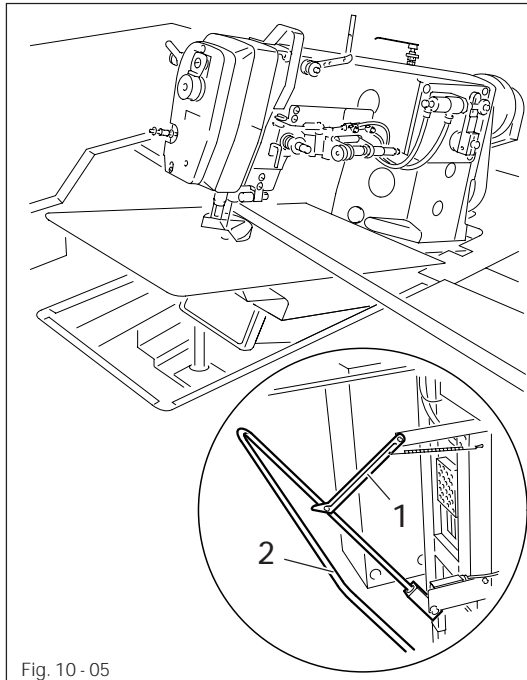

To replace the bobbin this way, the function **BOBBIN CHANGE FROM TOP** in the 2nd menu must be activated (see **chapter 11.03.03 Selecting a subfunction from the 2nd menu level**).



- With the machine in its home position, press the **change bobbin** key. (Transport arm with sewing jig is swung over to the folder station and the sewing head is tilted up.)
- Raise ratchet lever **1** and swing safety bar **2** until it rests against the machine.
- Carry out bobbin change (see **10.03.01 Bobbin change, bobbin case and bobbin thread tension**).
- Return safety bar **2** to its starting position.
- Activate the start keys on the folder station. (Sewing head tilts back down and transport arm with sewing jig swings to sewing station.)

10.03.03 Changing the bobbin from the top in AUTOMATIC mode

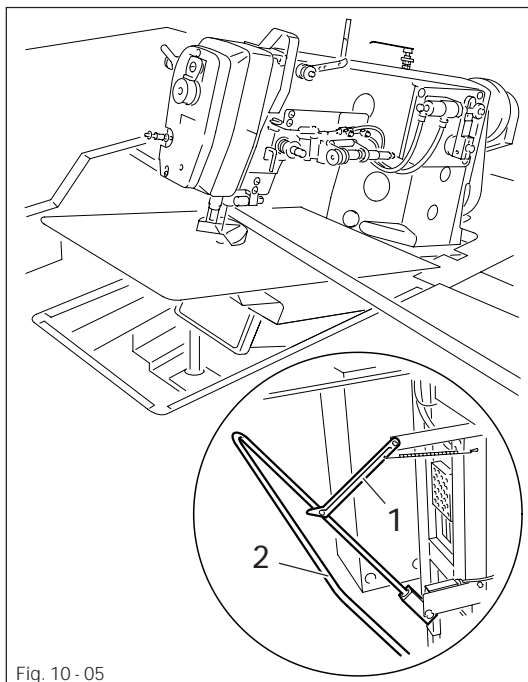

Fig. 10-05

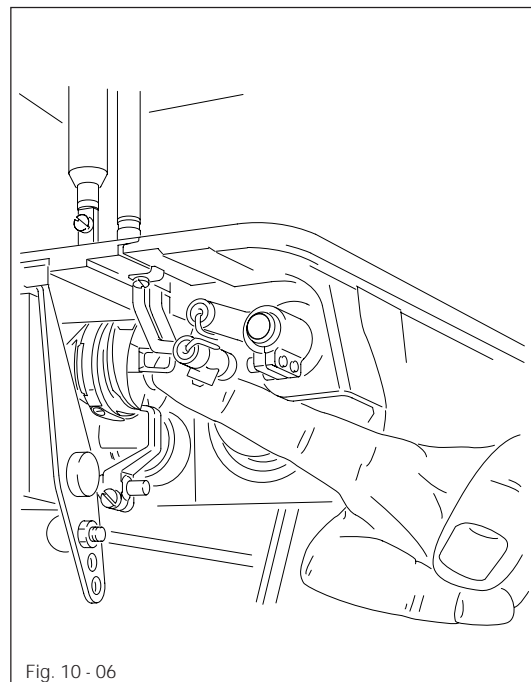

Fig. 10-06

When the number of the selected bobbin thread stitches has been completed, the transport arm with the sewing jig swings to the folder station.

Display: "CHANGE BOBBIN

#055"



The light diode of the **reset key** is lit and the sewing head automatically tilts up.

- Raise ratchet lever **1** and swing safety bar **2** until it rests against the machine.
- Carry out bobbin change (see 10.03.01 **Bobbin change, bobbin case and bobbin thread tension**).
- Return safety bar **2** to its starting position.



- Press **reset key** (light diode of the key goes off).

- Press the start keys on the folder station simultaneously (program is then continued).



When the machine is stopped during the sewing operation, the bobbin can only be changed from below since the sewing head cannot be tilted up (see 10.03.01 **Bobbin change, bobbin case and bobbin thread tension**).

## 10.04 Threading the needle thread

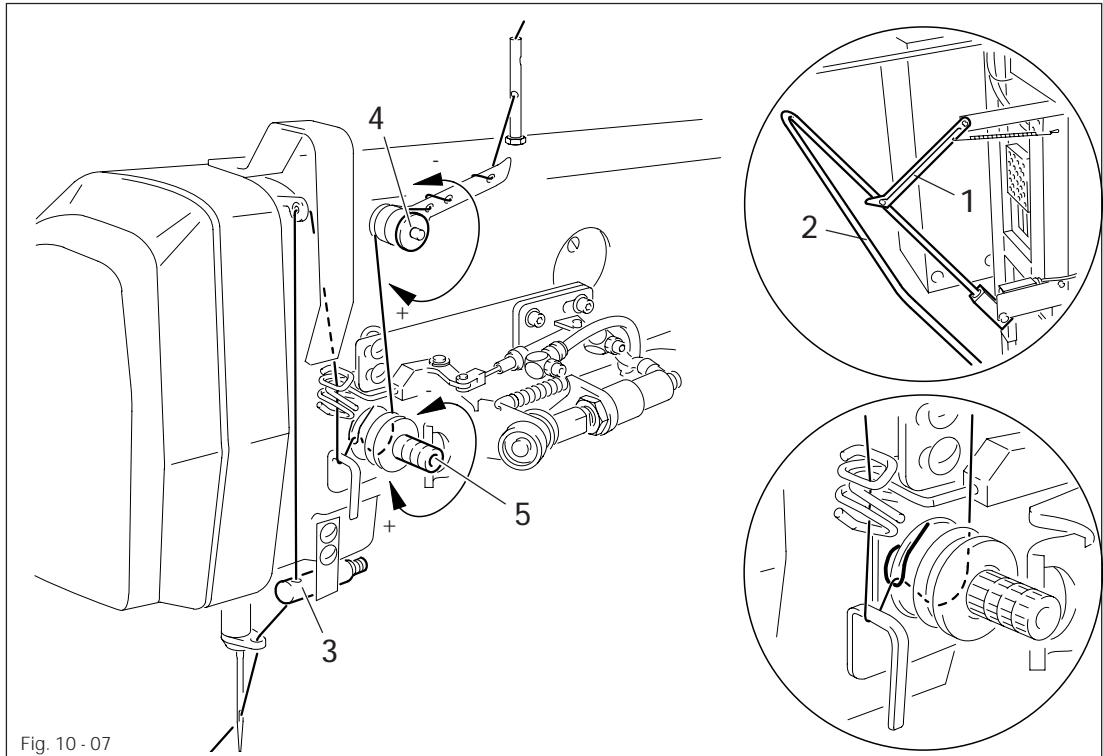

Fig. 10 - 07

- Raise ratchet lever 1 and swing safety bar 2 until it rests against the machine.



- Press **presser/thread trapper key** (presser is lowered and thread trapper 3 opens).



When the machine is in transport index:

- Press **seam pattern forwards key**

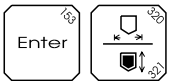

- Press **transport arm/ sewing jig key** (transport arm moves to folder station).

- Thread the needle thread according to Fig. 10-07.
- Adjust the thread pre-tension at nut 4.
- Regulate the thread main tension at nut 5.

In the sewing index:

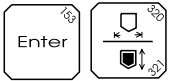

- Press **transport arm/ sewing jig key** (transport arm moves to folder station).

- Thread the needle thread according to Fig. 10-07.
- Adjust the thread pre-tension at nut 4.
- Regulate the thread main tension at nut 5.



- Press the **seam pattern backwards key**.
- Swing back safety bar 2 to its starting position.

10.05 Program number selection

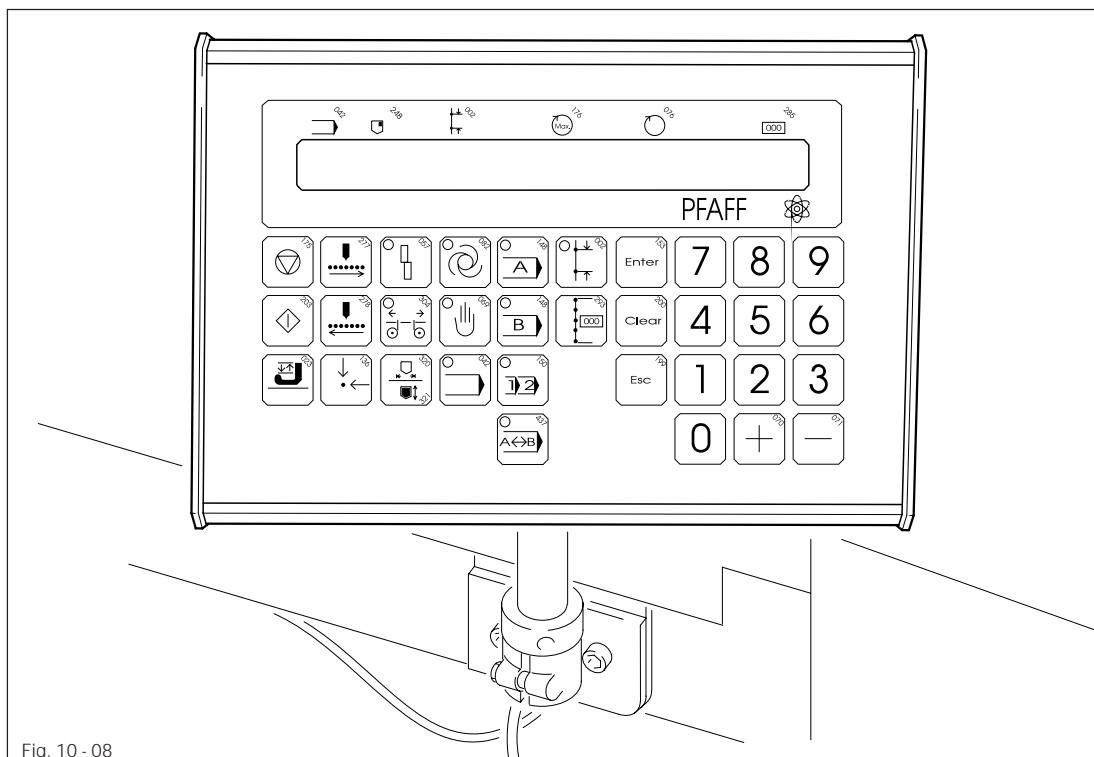
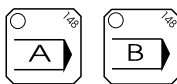

Fig. 10 - 08



- Select the **INPUT** mode.

Display: "CHOOSE FUNCTION OR SCROLL #250"



- Via the **station keys** select the program station in which the desired program is to be stored.



- Press the **program selection key**.



- Enter the number of the desired program with the **number keys**.

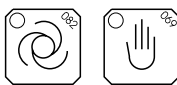

- End the input with the operation mode keys **AUTOMATIC** or **MANUAL**.



If the program selected is not in the machine memory, after you have made an entry, a warning is output.

Display: "PROGRAM NOT IN MEMORY #051"



When you change programs, remember that it may be necessary to also change the sewing jig and the folder part set.

## 10.06 Automatic change in program station

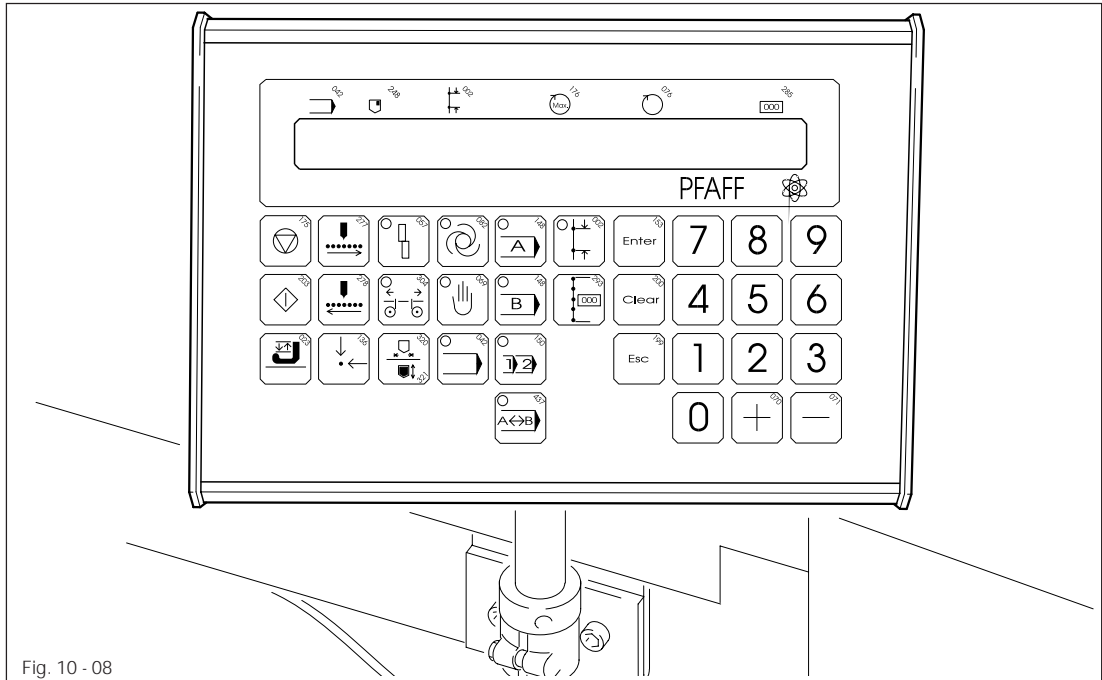

Fig. 10 - 08



If you want to change back and forth between two sewing programs, a program must be stored in each of both program stations (see **chapter 10.05 Program number selection**).



- Select the **INPUT** mode.

Display: "CHOOSE FUNCTION OR SCROLL #250"



- Press **automatic station change** key.



- End the input via the **AUTOMATIC** or **MANUAL** operation mode keys.



- Via the station keys, select the program station with the program you want to begin with.









## 10.07 Jig monitor ( optional )

To make it possible to monitor the jig, the sewing jig is given a code using magnets which the control can recognize via an additional device.

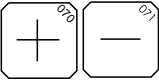
This is a means of preventing pairing a sewing program with the wrong sewing jig which could cause the needle to break.

If you want to monitor the jig, the function must be active in the menu, and a jig code must be entered in the sewing program.

### 10.07.01 Activating jig monitor (menu)

- 
  - Select the **INPUT** mode.
  - Display: "CHOOSE FUNCTION OR SCROLL #250"
- 
  - Via the **plus/minus keys**, scroll through the functions until you find display:
  - Display: "-2. MENU #261"
- 
  - Call up the 2nd menu level by pressing **Enter**.
  - Display: "2. MENU #300"
- 
  - Press **number key 4**.
  - Display: "SWITCH FUNCTIONS #560"
- 
  - Press **number key 4** again.
  - Display: "OTHER FUNCTIONS #660"
- 
  - Press **number key 3**.
  - Display: "JIG MONITOR OFF (ON:1) #675"
- 
  - Press **number key 1**.
  - Display: "JIG MONITOR ON (OFF:0)#676"
- 
  - Press **Enter** key.
  - Display: "-2. MENU #261"

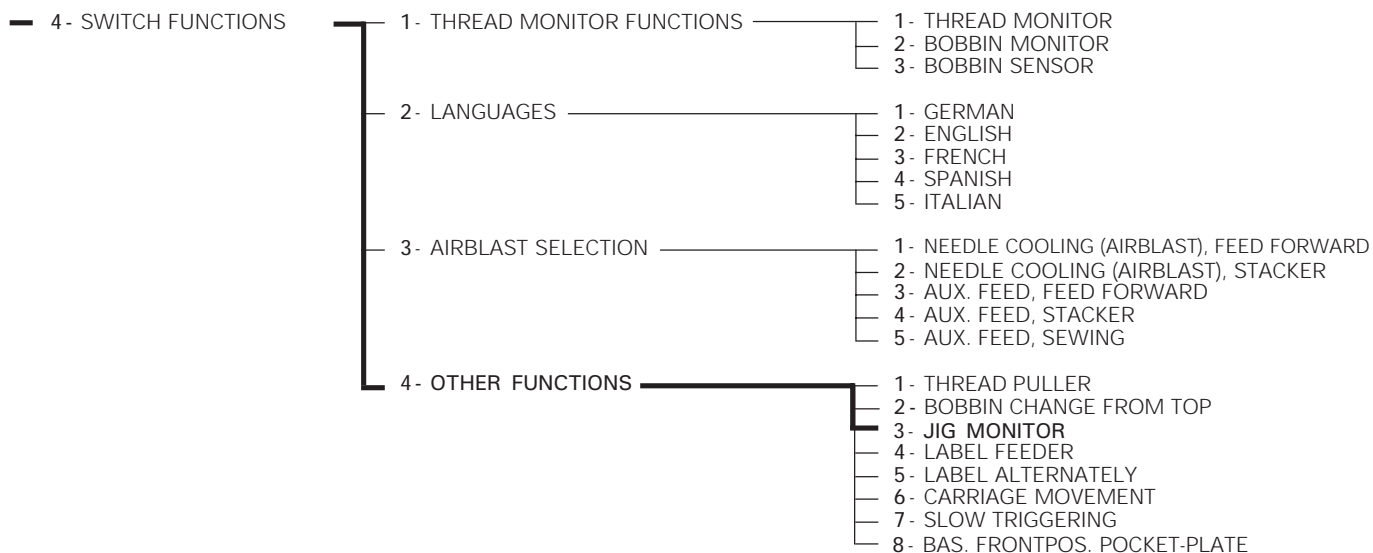

## 10.07.02 Determining the jig code

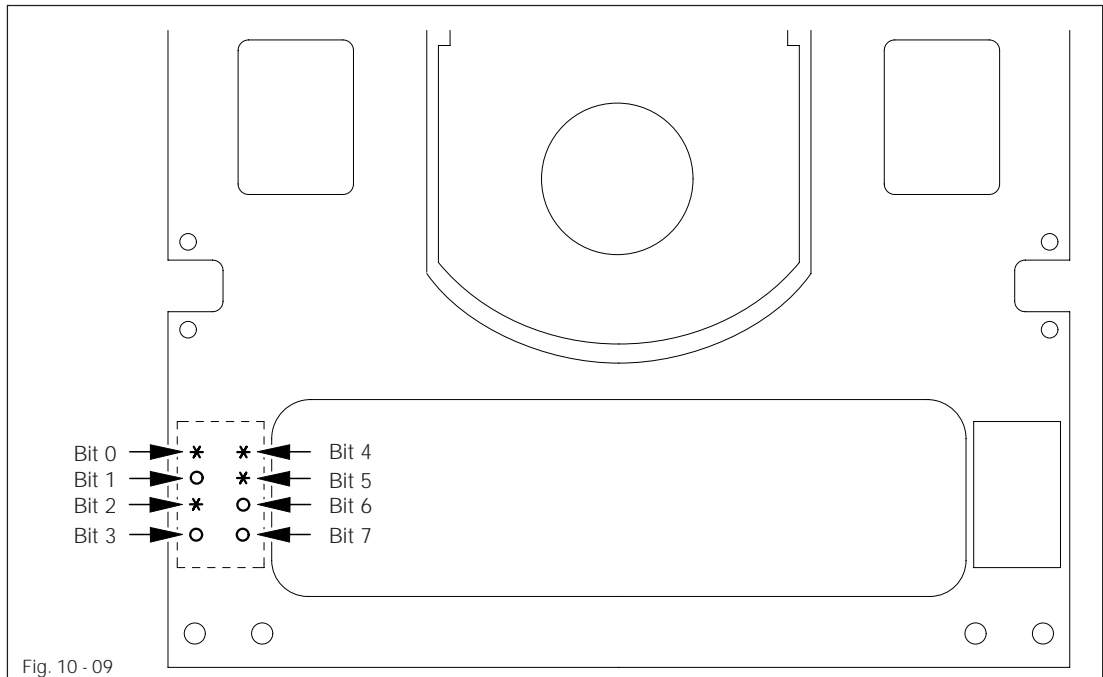

The jig code is entered in the sewing program as a number value (0-99).

The code is created on the jig as a binary number by arranging the magnets in a particular way.

Example: decimal number (25) is equal to the binary combination ( **0010** ) ( **0101** )

tens place ( 2 )
ones place ( 5 )

### Bit assignment

Ones place Tens place	Bit 3 Bit 7	Bit 2 Bit 6	Bit 1 Bit 5	Bit 0 Bit 4
0	free	free	free	free
1	free	free	free	magnet
2	free	free	magnet	free
3	free	free	magnet	magnet
4	free	magnet	free	free
5	free	magnet	free	magnet
6	free	magnet	magnet	free
7	free	magnet	magnet	magnet
8	magnet	free	free	free
9	magnet	free	free	magnet

## 10.08 Placement of the cuttings

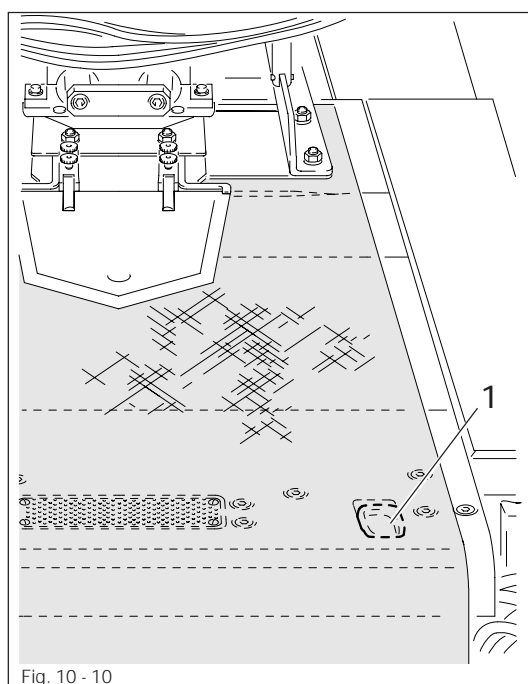

Fig. 10 - 10

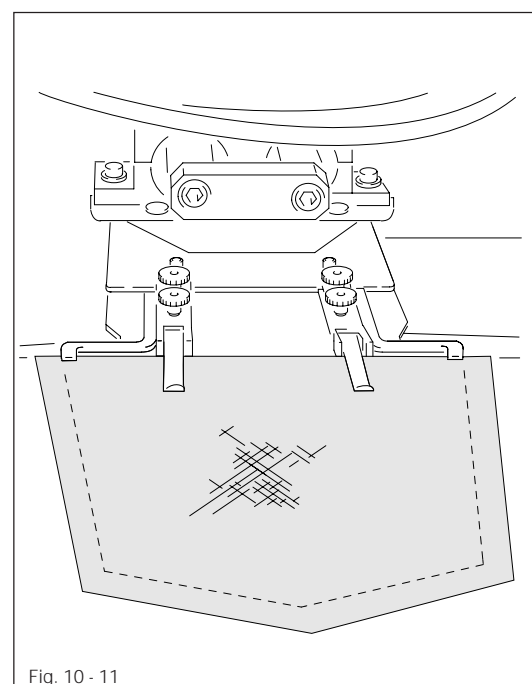

Fig. 10 - 11

- Lay the cutting on the table and, with control 1 activated, align.



Cuttings which have markings for the position of the pockets are aligned, if provided, according to the illumination markings.

For unmarked cuttings, mark the position of the pockets on the table.

- The placement and alignment of the pocket cuttings depends of the menu combination selected (see **chapter 8.05 Foot switch**).

Menu combination: HOME POSITION POCKET PLATE IN FRONT ON  
PLAIN FABRIC ON

- Slide the pocket cutting onto the pocket plate according to **Fig. 10-11**.

Menu combination: HOME POSITION POCKET PLATE IN FRONT ON  
PLAIN FABRIC OFF

- Slide the pocket cutting onto the pocket plate according to **Fig. 10-11**.
- Activate the foot switch (pocket plate is lowered).
- To align the pattern of the cutting and pocket, activate the foot switch again and hold (pocket plate is raised).

Menu combination: HOME POSITION POCKET PLATE IN FRONT OFF  
PLAIN FABRIC ON

- Activate the foot switch (pocket plate moves forward).
- Slide the pocket cutting onto the pocket plate according to **Fig. 10-11**.

Menu combination: HOME POSITION POCKET PLATE IN FRONT ON  
PLAIN FABRIC OFF

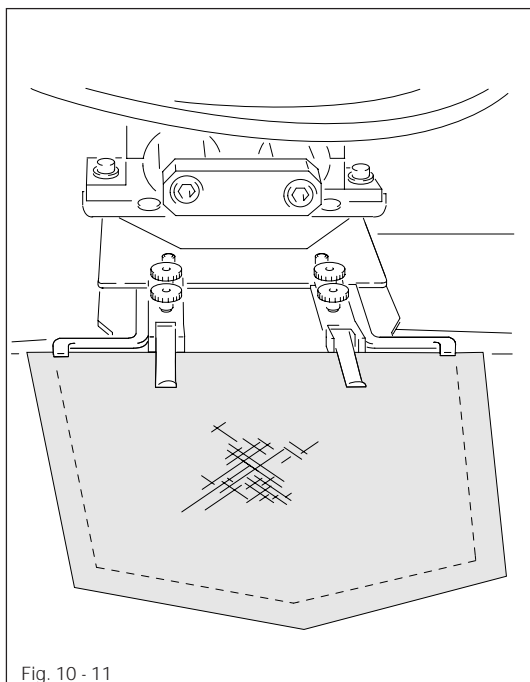

- Activate the foot switch (pocket plate moves forward).
- Slide the pocket cutting onto the pocket plate according to Fig. 10-11.
- Activate the foot switch (pocket plate is lowered).
- Activate the foot switch (pocket plate is lowered).

## 11 Programming

### 11.01 Brief description of Input mode



In the **INPUT** mode, it is necessary to differentiate between functions which can be selected directly and those of the 1st and 2nd menu levels.

#### 11.01.01 Direct functions

Direct functions are functions which are required more often than other functions. They can be selected directly via the corresponding keys.



Program station A



Program station B



Program selection



Automatic program change



Stitch length change



Reset stitch counter

#### 11.01.02 Summary of the functions in the 1st menu level

Functions which are required frequently are stored at this menu level. As is true for the direct functions, additional subfunctions cannot be selected. The only exception is if you want to enter the 2nd menu level.

Display: "CHOOSE FUNCTION OR SCROLL #250" (basic condition - 1st menu)

- 1- PIECE COUNTER
- 2- BOBBIN PRESELECT
- 3- TIME FOR FEED ROLLER
- 4- MAXIMUM SPEED
- 5- REDUCED SPEED
- 6- ZIGZAG DELAY ON
- 7- ZIGZAG DELAY OFF
- 8- INTERMEDIATE STOP
- 9- PULLER
- 0- PLAIN FABRIC
- Entry into 2. Menu



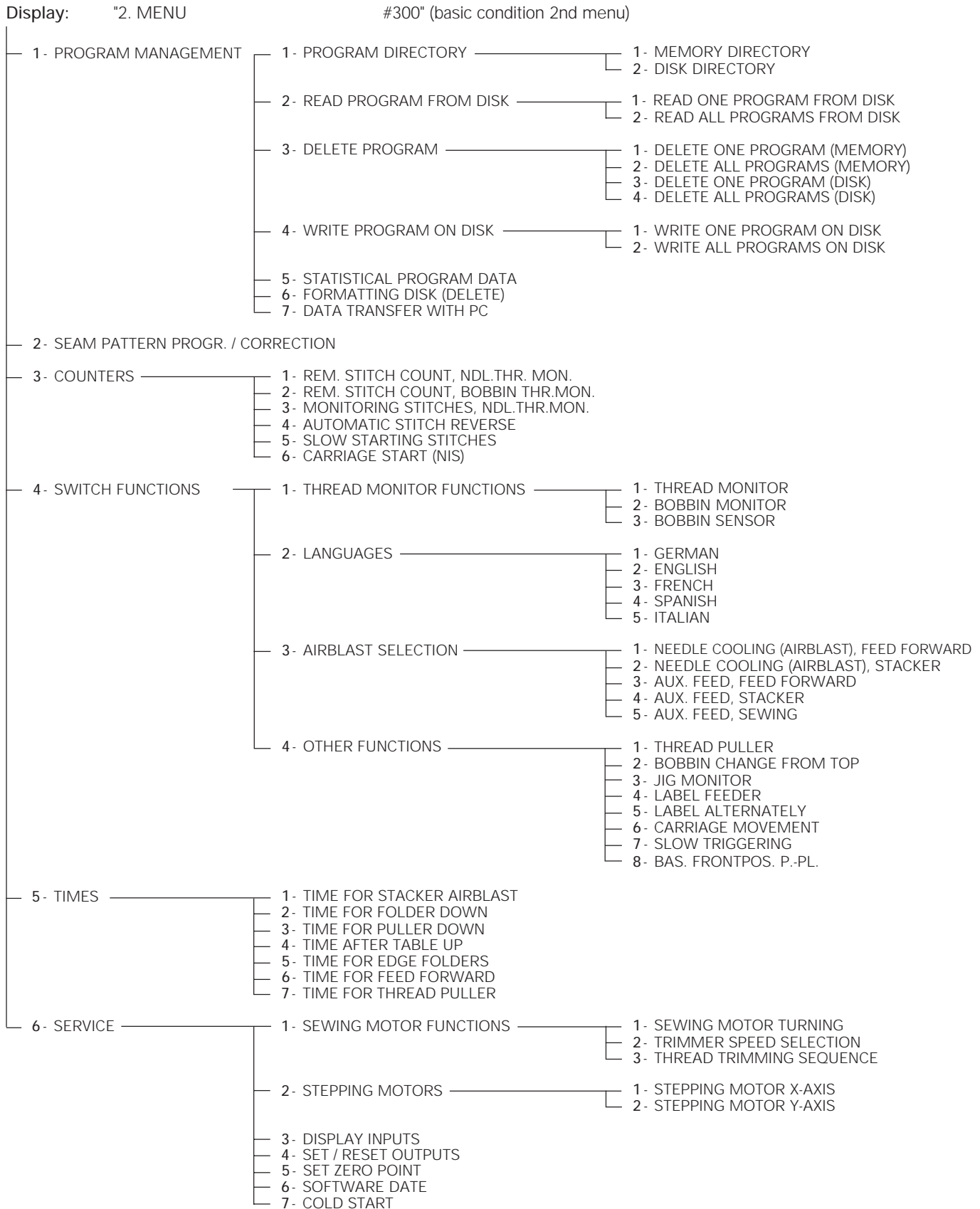

## 11.01.03 Summary of the functions in the 2nd menu level

Functions which are used less frequently are found in this menu level. Here, the functions are divided into main and subfunctions.



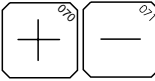

## 11.02 Description of the menu levels





### 11.02.01 1st menu level

-  ● After selecting the **INPUT** mode, you reach the basic position.  
 Display: "CHOOSE FUNCTION OR SCROLL #250"
-  ● Via the **plus/minus keys**, you can scroll between the functions.  
 e.g. Display: "1- PIECE COUNTER #251"
-  ● Use the **Enter key** to enter the function (display) selected in this manner.
-  ● The functions can also be called directly by pressing the corresponding number via the **number keys** (see chapter 11.01.02 Summary of the functions in the 1st menu level).
-  ● Selected functions can be interrupted via the **Esc key**.

### 11.02.02 Entering the 2nd menu level

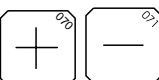
-  ● Select **INPUT** mode (basic position 1st menu).  
 Display: "CHOOSE FUNCTION OR SCROLL #250"
-  ● Scroll through the functions with the **plus/minus keys** until you find the display:  
 Display: "-2. MENU #261"
-  ● Call the 2nd menu level by pressing **Enter** (basic position - 2nd menu).  
 Display: "-2. MENU #300"





### 11.02.03 2nd menu level

-  ● After entering the 2nd menu level, you can also scroll back and forth between the main functions with the **plus/minus keys**.  
 e.g. Display: "3- COUNTERS #303"
-  ● To enter the function (display) selected in this way, use the **Enter key**.  
 z.B. Display: "COUNTERS #530"
-  ● Here, the functions can also be called directly via the **number keys** (see chapter 11.01.03 Summary of the functions in the 2nd menu level).
  - Behind most of the main functions are subfunctions which can be scrolled through (**plus/minus keys**), and which can be selected in the same way as the main functions (**Enter key** or **number keys**).
-  ● The functions can be interrupted with **Esc** (input values are not assumed). This will return you to the superordinate main or subfunctions.

## 11.03 Examples for selecting functions



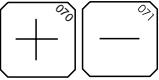

### 11.03.01 Selecting a direct function

To change the stitch length, for example, you must proceed as follows:

-  ● Select **INPUT** mode.  
Display: "CHOOSE FUNCTION OR SCROLL #250"
-  ● Press the **stitch length change** key.  
e.g. Display: "PROGRAM:1 STICHL.3.20 #262"
-  ● Enter the number of the program to be changed via the **number keys** (e.g. 34)  
e.g. Display: "PROGRAM:34 STICHL.2.50 #262"
-  ● Change the stitch length value using the **plus/minus** or the **number keys**.  
e.g. Display: "PROGRAM:34 STICHL.2.80 #262"
-  ● Confirm the entry with the **Enter key**.  
Display: "STITCH GENERATION RUNNING #264"
- The new stitch length value is assumed.  
Display: "CHOOSE FUNCTION OR SCROLL #250"

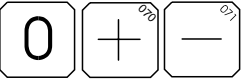
### 11.03.02 Selecting a function from the 1st menu level







To activate the PLAIN MATERIAL function, it is necessary to proceed as follows:

-  ● Select **INPUT** mode.  
Display: "CHOOSE FUNCTION OR SCROLL #250" (basic position 1st menu)
-  ● Scroll through the functions with the **plus/minus keys** until you find the display:  
Display: " 0- PLAIN FABRIC #260"
-  ● Via the **Enter key**, enter the selected function.  
(If the **number key 0** is pressed, you will enter immediately from the basic position.)  
Display: "PLAIN FABRIC OFF (ON:1) #291"
-  ● Press **number key 1** to activate the function.  
Display: "PLAIN FABRIC ON (OFF:0)#292"
-  ● Confirm the entry with the **Enter key**.  
Display: "CHOOSE FUNCTION OR SCROLL #250"

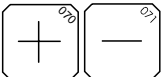

## 11.03.03 Selecting a subfunction from the 2nd menu level

The BOBBIN CHANGE FROM TOP function is to be activated. In this example, only a description of how to enter this function with the number keys is given. The individual functions can be selected as described in the above examples, as well as via the **plus/minus** keys and called with the **Enter** key.

- 
  - Select **INPUT** mode (basic position 1st menu).  
Display: "CHOOSE FUNCTION OR SCROLL #250" (basic position 1st menu)
- 
  - Scroll through the functions with the **plus/minus** keys until you find the display:  
Display: "-2. MENU #261"
- 
  - Call the 2nd menu level by pressing **Enter**  
Display: "2. MENU #300" (basic position 2nd menu)
- 
  - Press **number key 4**.  
Display: "SWITCH FUNCTIONS #560"
- 
  - Press **number key 4** again.  
Display: "OTHER FUNCTIONS #660"
- 
  - Press **number key 2**.  
Display: "BOBBIN CHANGE FROM TOP OFF (ON:1) #673"
- 
  - Press **number key 1**.  
Display: "BOBBIN CHANGE FROM TOP ON (OFF:0)#674"
- 
  - Press **Enter**.  
Display: "-2. MENU #261"

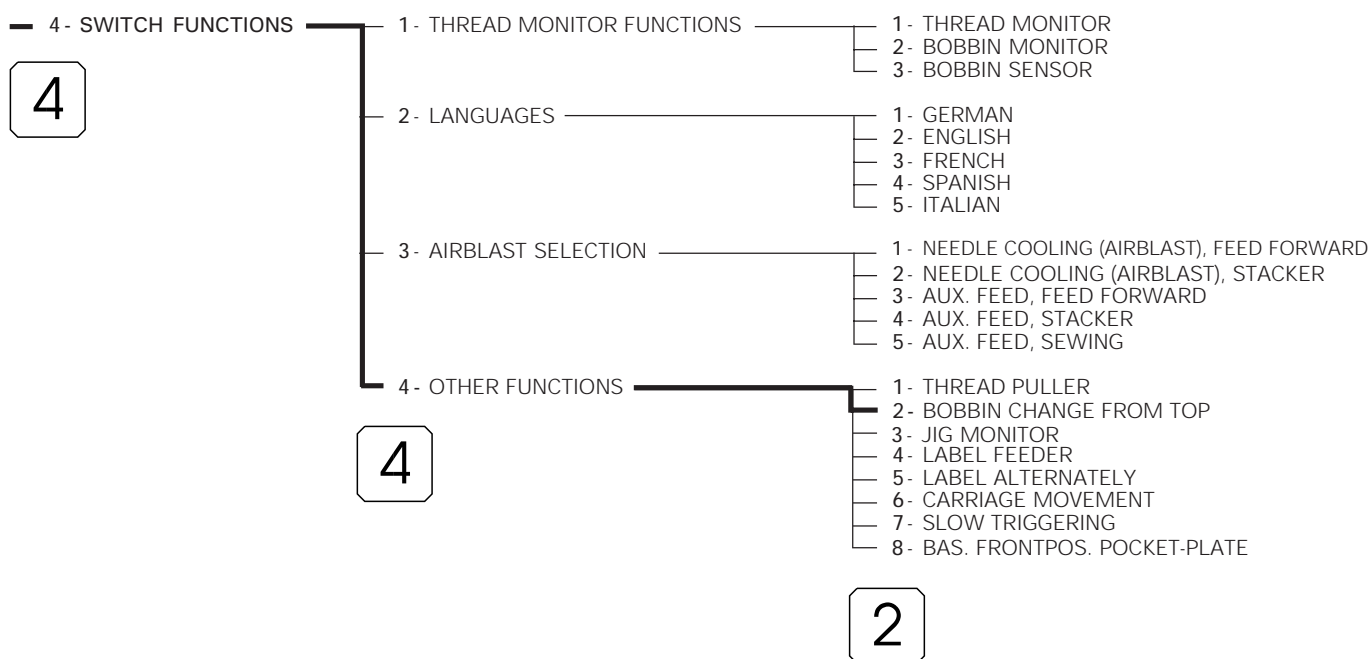

From the basic position in the 2nd menu level, the required function can also be called directly by entering the number combination 4-4-2.

## 11.04 Explanation of the menu functions

### 11.04.01 Functions in the 1st menu level

#### 1- PIECE COUNTER



Provides information on the current daily production (max. display value: 65565).

The value can be reset to "0" with the **Clear key**.

The value is not changed when the machine is turned off. If the max. display value is exceeded, the counter is reset automatically.

#### 2- BOBBIN PRESELECT

When the preset stitch count is reached, the machine stops automatically at the end of the seam pattern to change the bobbin. When this function is selected, the value entered is displayed.

The value can be changed using the **plus/minus keys** or the **number keys**.

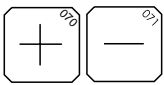

#### 3- TIME FOR FEED ROLLER

When this function is selected, the running time of the feed rollers for stacking is displayed in seconds.

The running time can be changed via the **plus/minus keys** or the **number keys**. The running time is a function of the length of the workpiece and should be set so that the pieces are stacked in the middle of the stack trestle.

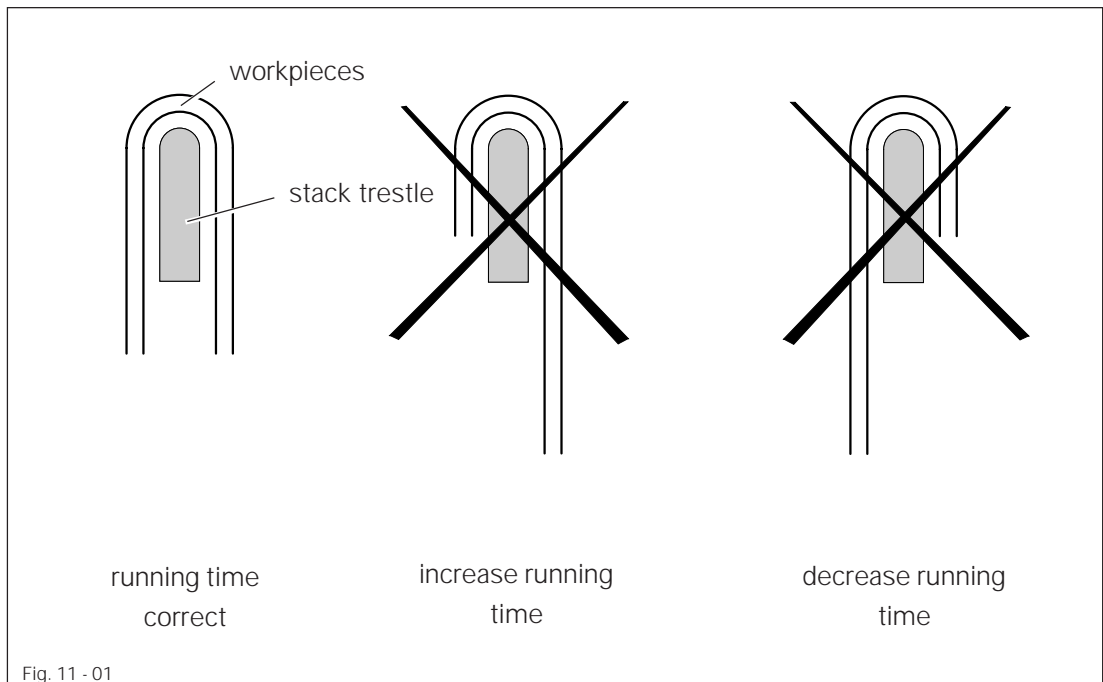

#### 4- MAXIMUM SPEED

When this function is selected, the max. speed which has been set is displayed.

The value can be changed using the **plus/minus keys** or the **number keys**.

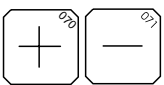

#### 5- REDUCED SPEED

When this function is selected, the reduced speed which has been set is displayed.

The value can be changed using the **plus/minus keys** or the **number keys**.

6- ZIGZAG DELAY ON

Displays the stitch count according to which the command "Zigzag on" is output before the bar tack is started. The stitch count can be changed using the **plus/minus keys** or the **number keys** (see Fig. 11.02).

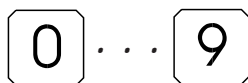
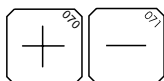

7- ZIGZAG DELAY OFF

Displays the stitch count according to which the command "Zigzag off" is output before the end of the bar tack. The stitch count can be changed using the **plus/minus keys** or the **number keys** (see Fig. 11.02).

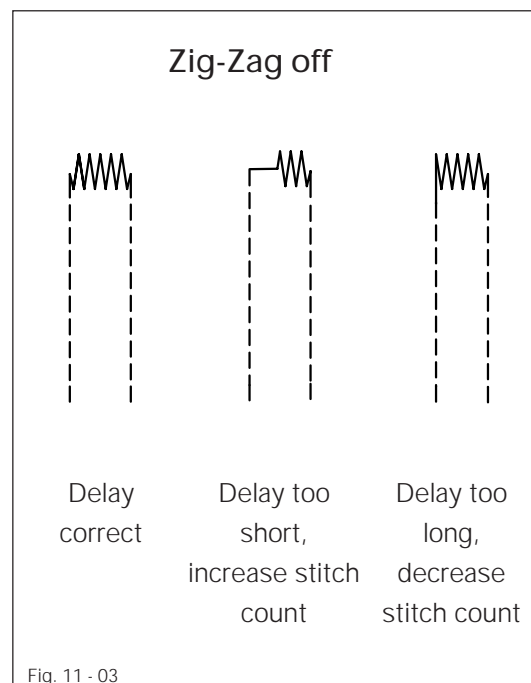
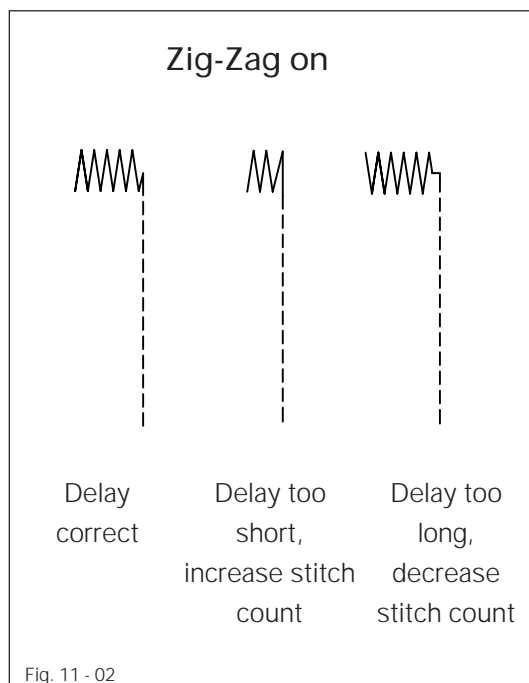

Due to the delay of the valve and cylinder, output of the commands for DELAY ZIGZAG ON and OFF must be delayed as a function of the speed.

8- INTERMEDIATE STOP

When this function is selected, the display shows whether the function is on or off. In the **AUTOMATIC** mode, the function causes a program stop after the folding operation is completed. After pressing both start controls the program is continued. Via the **number keys 1 and/or 0**, the function can be turned on or off.



9- PULLER

The puller is a work aid for stacking short workpieces.

When the function is selected, the display indicated whether this function is on or off. Via the **number keys 1 and/or 0**, the function can be turned on or off.



0- PLAIN FABRIC

This function changes the foot switch and start control functions for processing plain fabric.

When the function is selected, the display indicates whether the function is on or off.



Via the **number keys 1 and/or 0**, the function can be turned on or off.

## -2. MENU

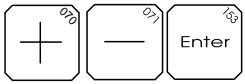

After selecting this function via the **plus/minus keys**, you can enter the 2nd menu level by pressing **Enter**.

### 11.04.02 Functions in the 2nd menu level

The functions are divided into main and subfunctions here.

#### 1- PROGRAM MANAGEMENT

All of the subfunctions are listed here which have to do with organizing the sewing programs.

##### 1- PROGRAM DIRECTORY

From these subfunctions, further subfunctions can be selected.

###### 1- MEMORY DIRECTORY

###### 2- DISK DIRECTORY

Depending on the selected subfunction, all of the programs of the memory or all of the programs on a disk are listed.

If one line in the display is not sufficient for displaying all of the programs, the **Enter key** serves as a scrolling function.



##### 2- READ PROGRAM FROM DISK

From this subfunction, further subfunctions can be called.

###### 1 - READ ONE PROGRAM FROM DISK

###### 2 - READ ALL PROGRAMS FROM DISK

Depending on the selected subfunction, all of the programs or one particular program on a disk can be read into the machine memory.

##### 3- DELETE PROGRAM

From this subfunction, further subfunctions can be called.

###### 1 - DELETE ONE PROGRAM (MEMORY)

###### 2 - DELETE ALL PROGRAMS (MEMORY)

###### 3 - DELETE ONE PROGRAM (DISK)

###### 4 - DELETE ALL PROGRAMS (DISK)

Depending on the selected subfunction, all of the programs or one particular program in the machine memory or on a disk can be deleted.

##### 4- WRITE PROGRAM ON DISK

From this subfunction, further subfunctions can be called.

###### 1 - WRITE ONE PROGRAM ON DISK

###### 2 - WRITE ALL PROGRAMS ON DISK

Depending on the selected subfunction, all of the programs or one particular program from the machine memory can be written on a disk.

## 5- STATISTICAL PROGRAM DATA

The following program data are displayed with this main function:

- stitch count and program length in bytes
- stitch count and obstacles
- jig code

## 6- FORMATTING DISK (DELETE)

Via this main function, disks can be reformatted (720 KB).



All of the data on the disk are deleted when the disk is formatted.

## 7- DATA TRANSFER WITH PC

Via this function, the control is made ready to transmit in order to communicate directly with a PC via the SYS 3000 software.

## 2- SEAM PATTERN PROGR. / CORRECTION

Programs can be created directly on the machine or corrected. To do this, a separate programming field is required. A detailed explanation of programming is discussed in a separate manual.

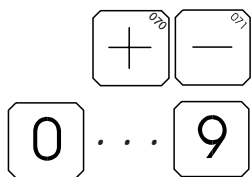

## 3- COUNTERS

The user can program counters according to his requirements in the subfunctions.

The values are always changed using the **plus/minus keys** or the **number keys**.

### 1- REM. STITCH COUNT, NDL. THR. MON.

The number of stitches can be set for which the needle thread monitor is not activated while the workpiece is being sewn on.

### 2- REM. STITCH COUNT, BOBBIN THR. MON.

The number of stitches can be set for which the bobbin thread monitor is not activated.

### 3- MONITORING STITCHES, NDL. THR. MON.

The number of stitches can be set for which a thread disturbance is to be ignored. A small number of stitches means that the needle thread monitor is more sensitive.

### 4- AUTOMATIC STITCH REVERSE

The number of stitches can be set by which, when there is a thread disturbance, the needle automatically goes back.

### 5- SLOW STARTING STITCHES

The number of stitches can be set which are to be carried out when sewing on the workpiece with reduced speed.

## 6- CARRIAGE START (NIS = needle in material)

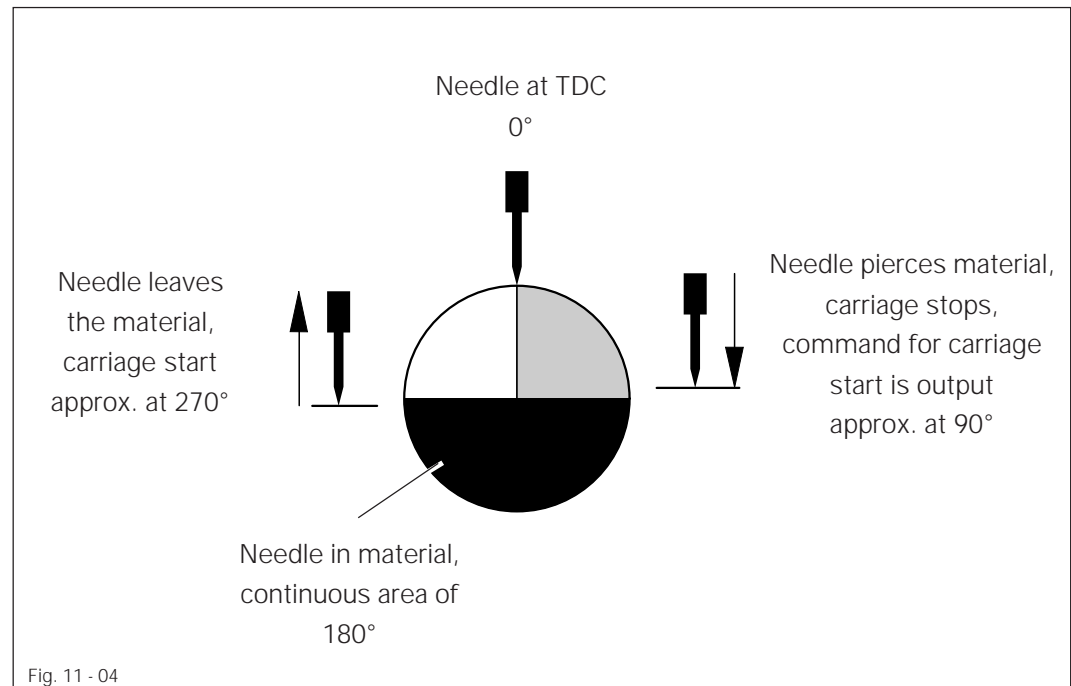

The command for the carriage start is output when the needle pierces the material. However, the carriage actually starts when the needle leaves the material (constant 180° later). The point in time for the output of the carriage start command can be changed in the range of 0 - 360°.



Under certain conditions, the stitch formation can be influenced by the setting. To avoid thread disturbances, the value should be between 60° and 120°.

## 4- SWITCH FUNCTIONS

Under this main function, the user can program machine functions according to his requirements in the subfunctions.

### 1- THREAD MONITOR FUNCTIONS

Thread monitor functions are listed here which can be turned on or off via the number keys 1 or 0.



- 1- THREAD MONITOR
- 2- BOBBIN MONITOR
- 3- BOBBIN SENSOR (option)

### 2- LANGUAGES

Several languages are listed here from which the desired user language can be selected.

- 1- GERMAN
- 2- ENGLISH
- 3- FRENCH
- 4- SPANISH
- 5- ITALIAN

### 3- AIRBLAST SELECTION



Airblast functions are listed here which can be turned on or off via the **number keys 1** or **0**.

#### 1- NEEDLE COOLING (AIRBLAST), FEED FORWARD

When the function is active, it prevents the starting thread from being pushed under the presser during fabric transport to the sewing station.

#### 2- NEEDLE COOLING (AIRBLAST), STACKER

Airblast during stacker operation.

#### 3- AUX. FEED, FEED FORWARD

Airblast during fabric transport to sewing station.

#### 4- AUX. FEED, STACKER

Airblast during stacker operation.

#### 5- AUX. FEED, SEWING

Airblast during sewing operation.

### 4- OTHER FUNCTIONS



Under this subfunction are other subfunctions which can be turned on or off with the **number keys 1** or **0**.

#### 1 - THREAD PULLER

Increases the amount of thread when starting sewing.

#### 2 - BOBBIN CHANGE FROM TOP

Sewing head tilts up automatically for changing the bobbin.

#### 3 - JIG MONITOR (option)

#### 4 - LABEL FEEDER (option)

The label is fed automatically.

#### 5 - LABEL ALTERNATELY (option)

The label is fed automatically during every other folding operation.

#### 6- CARRIAGE MOVEMENT

When this function is on, the carriage moves continuously during sewing.

When this function is on, the carriage moves intermittently, e. g. when the needle is in the material the carriage feed stops.

#### 7 - SLOW TRIGGERING

The triggering speed of the sewing jig from zero point to sewing on point is reduced to prevent thin material from shifting.

#### 8 - HOME POSITION POCKET PLATE IN FRONT

When this function is on, the pocket plate moves automatically forward for inserting the pocket cutting.

When the function is not active, the pocket plate moves forward only after the foot switch has been pressed.

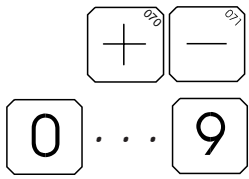

## 5- TIMES

Under this main function, times are listed which can be set via the **plus/minus keys** or the **number keys**.

### 1- TIME FOR STACKER AIRBLAST

The time is to be set so that the stacker goods are blown properly over the stacker trestle.

### 2- TIME FOR FOLDER DOWN

The time is to be set so that the function "folder down" already begins during the function "folder forward", but is just ended in the forward end position of the folder.

### 3- TIME FOR PULLER DOWN

The time is to be set so that the puller is lowered only after the sewing jig has moved out of the puller area.

### 4- TIME AFTER TABLE UP

The time is to be set so that the folder plates don't move back until the table is at the top.

### 5- TIME FOR EDGE FOLDERS

The time is to be set so that the folder moves to the top after the folder plate is at the back end position.

### 6- TIME FOR FEED FORWARD

The time is to be set so that the sewing jig feed from the folder station to the sewing station is carried out after the pocket plate has moved out of the jig area.

### 7- TIME FOR THREAD PULLER

The time is to be set so that the thread puller cylinder can carry out the complete stroke.

## 6- SERVICE

The service functions are only intended for the mechanics. A detailed description is found in the service manual for the machine control.

### 1- SEWING MOTOR FUNCTIONS

#### 1- SEWING MOTOR TURNING

#### 2- TRIMMER SPEED SELECTION

#### 3- THREAD TRIMMING SEQUENCE

### 2- STEPPING MOTORS

#### 1- STEPPING MOTOR X-AXIS

#### 2- STEPPING MOTOR Y-AXIS

### 3- DISPLAY INPUTS

### 4- SET / RESET OUTPUTS

### 5- SET ZERO POINT

### 6- SOFTWARE DATE

### 7- COLD START



## 11.05 Sewing



This machine must only be operated by adequately trained operators!  
The operators must also ensure that only authorized persons have access to the potentially dangerous area around the machine!



The program may only be started after the cover **1** of the X/Y carriage control has been closed!



During the program cycle, do not reach into the folder or the sewing station area! Danger of serious injury!



During the program cycle, do not reach into the swivel range of the transport arm! Danger of serious injury!

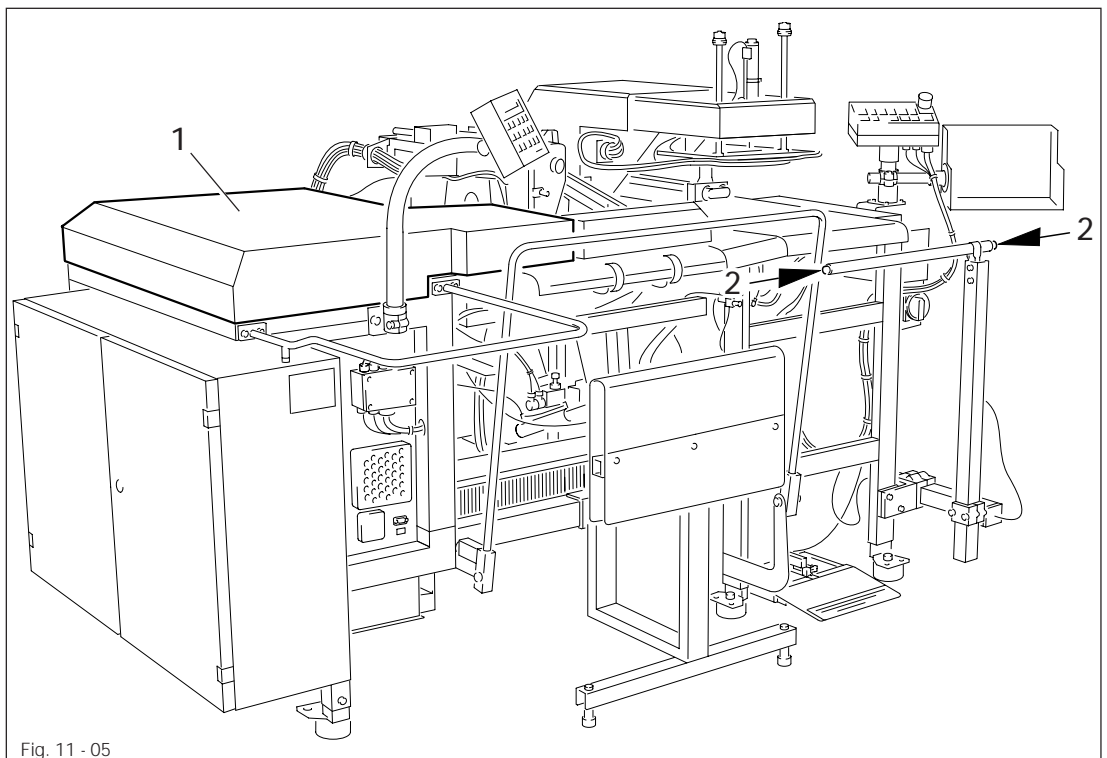

Fig. 11 - 05

### 11.05.01 Sewing in the AUTOMATIC mode



- Insert workpiece and align (see chapter 10.08 Placement of the cuttings).

- Select **AUTOMATIC** mode.



- Press key for **program start**.  
(Machine switches to automatic program cycle).

- Press start controls **2** at the same time (the entire work cycle is carried out automatically).

## 11.05.02 Sewing in the MANUAL mode

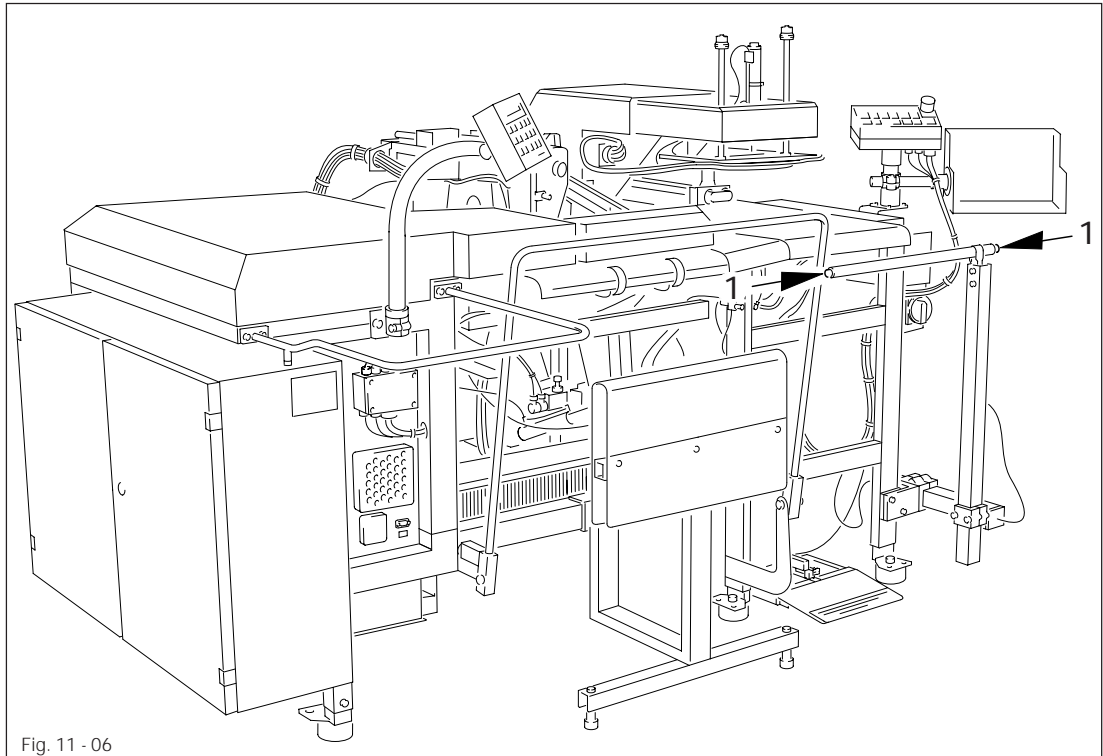

Fig. 11 - 06

- Insert workpiece and align (see **chapter 10.08 Placement of the cuttings**).
- Select **MANUAL** mode.
- Press start controls **1** at the same time (the function is dependent on the menu selection; see **chapter 8.06 Start controls**).



- Start the cycle of functions of the folder by pressing the **folder movement** key repeatedly.

- Lower folder and table
- Engage folder slide, raise table, retract folder slide.
- Raise folder
- Swing transport arm with sewing jig to folder station; stacker functional
- Return folder
- Lower sewing jig
- Return pocket plate
- Swing transport arm with sewing jig to sewing station



- Press key for **program start** (seam program is started).

11.05.03 Disturbances

If thread breakage occurs, the following message appears, for example, in the control panel display of the sewing station:

Display: "THREAD ERROR #008"

- The machine moves back automatically by the number of stitches selected in the menu and stops.
- Thread the needle (see chapter 10.04 Threading the needle thread).



- If necessary, press the **seam pattern forwards** and/or **seam pattern backwards** keys until you come to the position from which sewing is to be continued.



- Press **program start** key (program cycle is continued).

12 Care and maintenance

Clean the entire machine .....	weekly
Clean the hook compartment .....	several times daily
Clean needle area .....	several times daily
Check oil level for sewing head lubrication .....	weekly
Check oil level for zigzag drive .....	daily before use
Lubricate X/Y carriage guides .....	every 6 months
Lubricate jig changeover .....	every 6 months
Clean the blower air filter .....	as required
Check air pressure .....	daily before use
Clean air filter of the compressed air unit .....	as required
Clean the vaporizer jet of the compressed air unit .....	as required
Adjusting the drip feed rate on the oil vaporizer .....	as required
Check the oil level of the compressed air unit .....	daily before use



These maintenance intervals are calculated for the average running time of a single-shift operation. If the machine is operated more often, shorter intervals are recommended.

## 12.01 Cleaning the machine

The required cleaning cycle for the sewing machine is dependent on the following factors:

- Single or multi-shift operation
- Accumulation of dust from the various fabrics

Thus, appropriate cleaning instructions can only be determined on an individual basis for each machine.

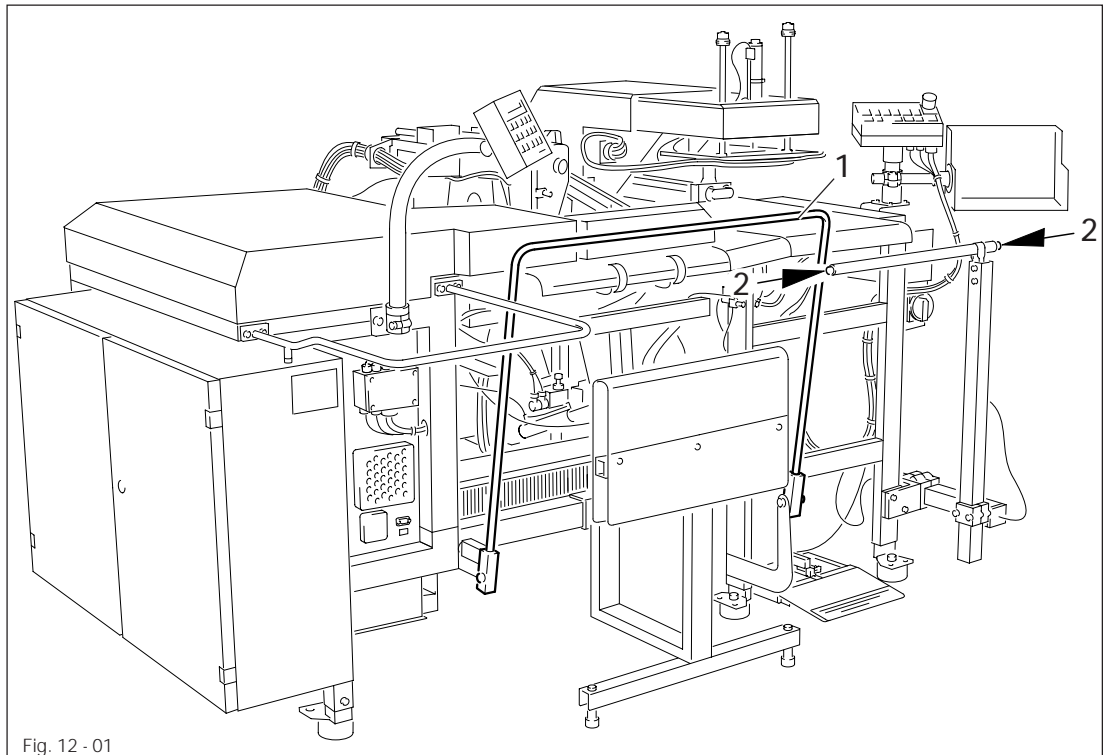

Fig. 12 - 01

To avoid operation disturbances, we recommend the following cleaning work for a machine in single shift operation:



- Clean the hook compartment and the needle area of the sewing head several times daily.
- Clean the entire machine at least once a week.

To do this:



- Select **MANUAL** operation mode.



- With the machine in home position, press the **change bobbin** key.  
(Transport arm with sewing jig swings to folder station and sewing head tilts up).
- Raise ratchet lever and swing in safety bar **1** toward the machine.
- Swing back safety bar **1** to its starting position.
- Press the start controls **1** simultaneously.  
(Sewing head tilts down and transport arm with sewing jig swings to sewing station).



When the machine is being cleaned, make sure that the safety bar **1** is swung in against the machine! Danger of injury!

## 12.02 Lubricating the sewing head

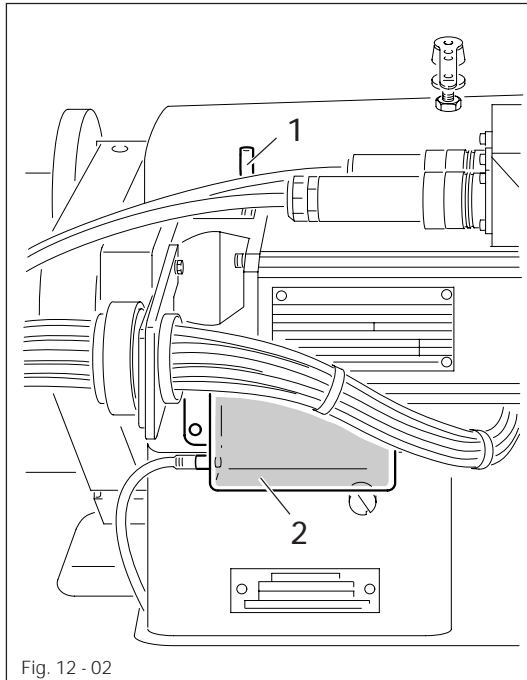

Fig. 12 - 02

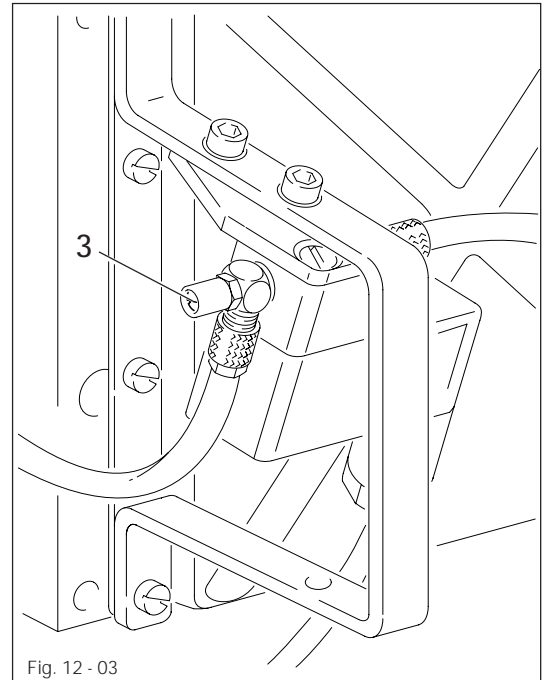

Fig. 12 - 03



Only use oil with a mean viscosity of 22.0 mm<sup>2</sup>/s at 40°C and a density of 0.865 g/cm<sup>3</sup> at 15°C.



- Raise ratchet lever and swing safety bar toward the machine.
- Pour oil through the hose 1 into oil reservoir 2.
- Before the machine is first operated or whenever the machine has been at a standstill for a longer period of time, also add a few drops of oil to the hook race.
- The oil flow rate can be regulated by turning the screw 3 at the underside of the machine.
- Swing back safety bar to its starting position.



The wicks in the oil reservoir 2 must always be immersed in oil!

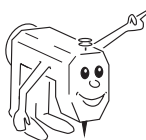

We recommend PFAFF sewing machine oil, part no. 280-1-120 144.

12.03 Lubricating the zigzag drive

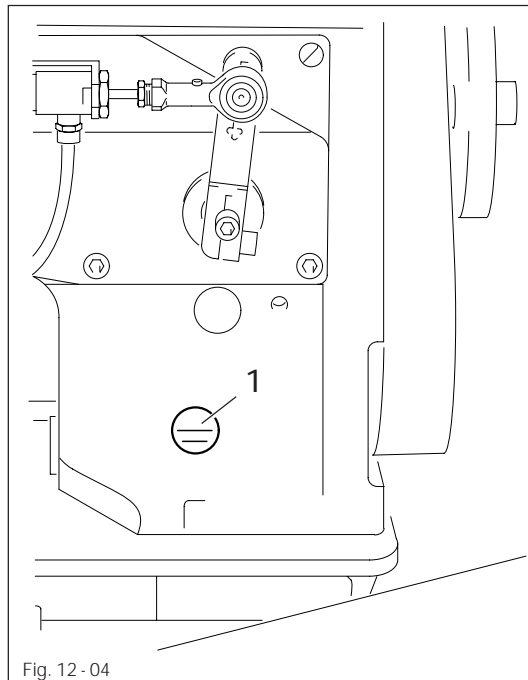

Fig. 12-04

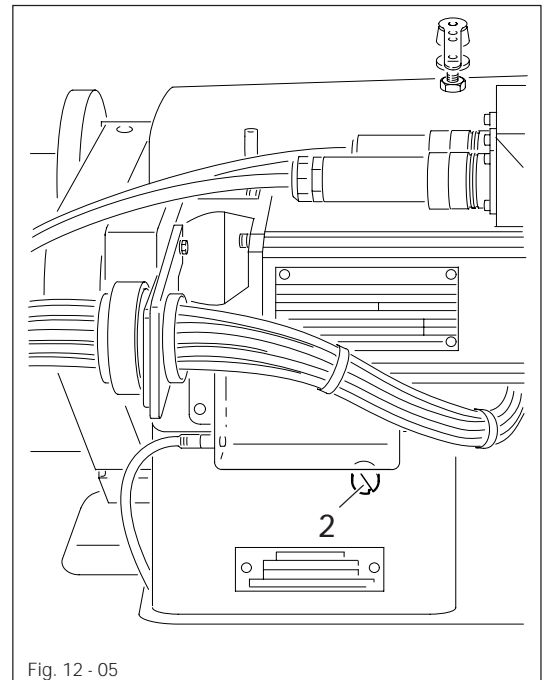

Fig. 12-05



Always check the oil level at window 1 before operating the machine!



Only use oil with a mean viscosity of 22.0 mm<sup>2</sup>/s at 40°C and a density of 0.865 g/cm<sup>3</sup> at 15°C.

When required:



- Raise ratchet lever and swing in safety bar toward the machine as far as it will go.
- Unscrew screw 2.
- Pour in oil until it is level with the uppermost mark.
- Tighten screw 2.
- Return safety bar to its starting position.



Never allow the oil level to fall below the lower mark on the window 1!

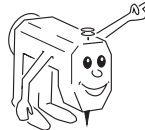

We recommend PFAFF sewing machine oil, Part no. 280-1-120 144.

## 12.04 Lubricating the carriage guides of the X/Y control

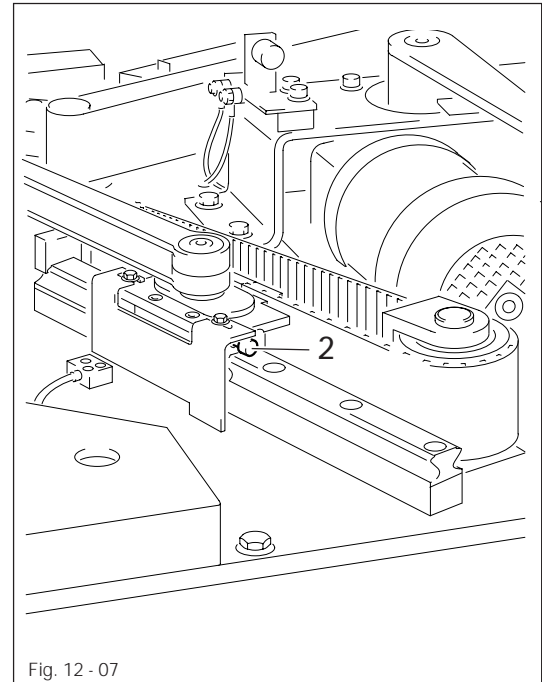
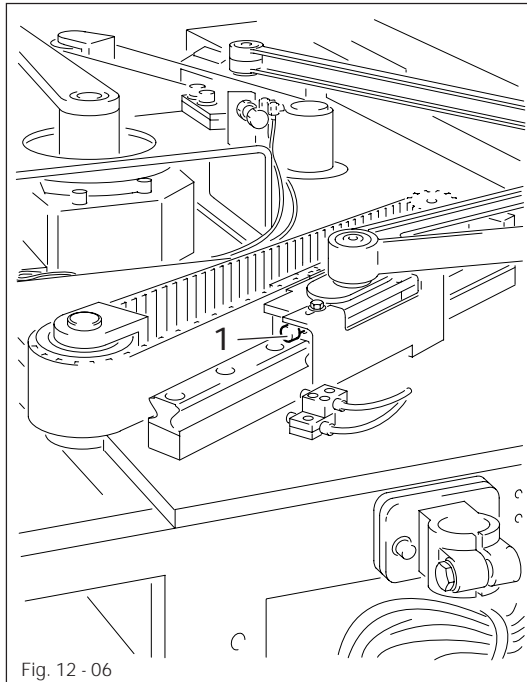

Turn off main switch and ensure that it cannot be turned on accidentally!



Only use heavy-duty grease with a penetration of 265-295 and a dripping point of 185°C.



- Open X/Y control cover.
- Lubricate both guides via the grease nipples 1 and 2 with a grease gun. This should be done every 6 months for single-shift operation and every 3 months for double-shift operation.
- Close X/Y control cover.

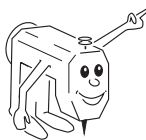

We recommend lithium soap grease, Molykote BR 2 plus,  
Part no. 280-1-120-207.



12.05 Lubricating jig changeover

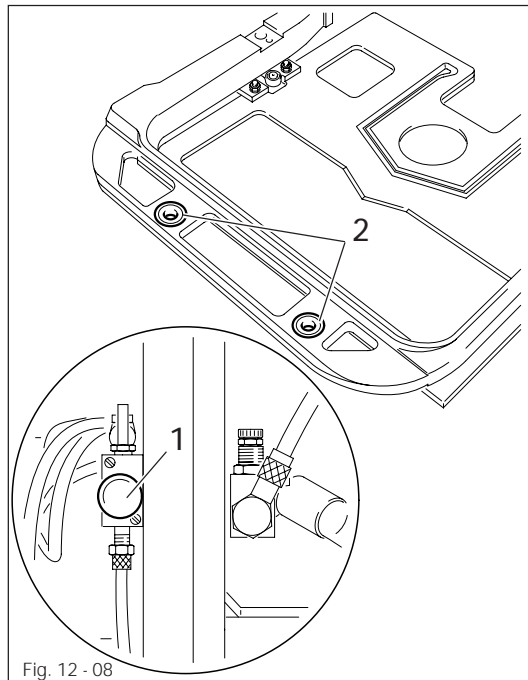

Fig. 12 - 08

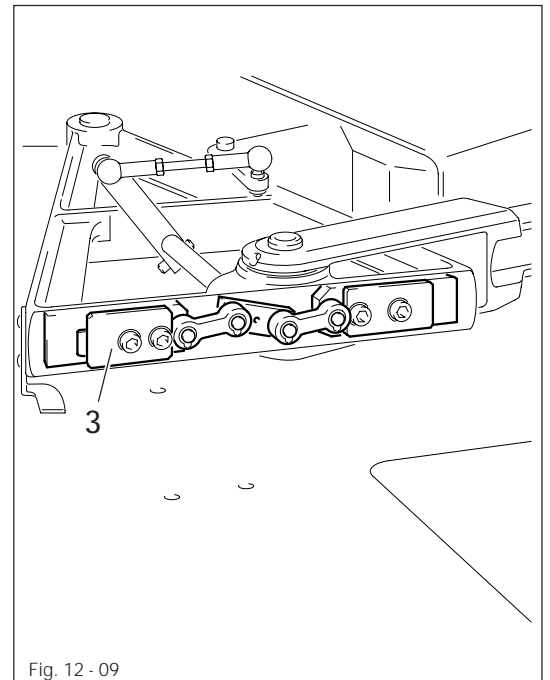

Fig. 12 - 09



Grease the parts described below regularly with Retinax G (sodium-base grease; dripping point 135°C), Part. no. 280-1-120 243.



- Press the **home position** key on the control panel of the folder station. (Transport arm with sewing jig swings to home position).

- Press key **1** for the sewing jig changeover. (Changeover of transport arm and sewing jig frame is released.)



- Remove sewing jig frame and grease the changeover bushes **2**.

- Also lightly grease the catch **3** of the X/Y control.

- Position the sewing jig frame on the transport arm and activate key **1**. (Changeover is now closed again.)

## 12.06 Cleaning the blower air filter

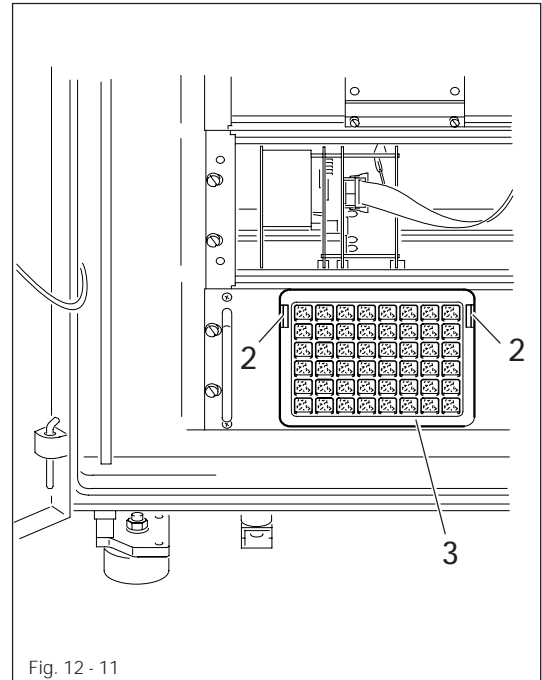
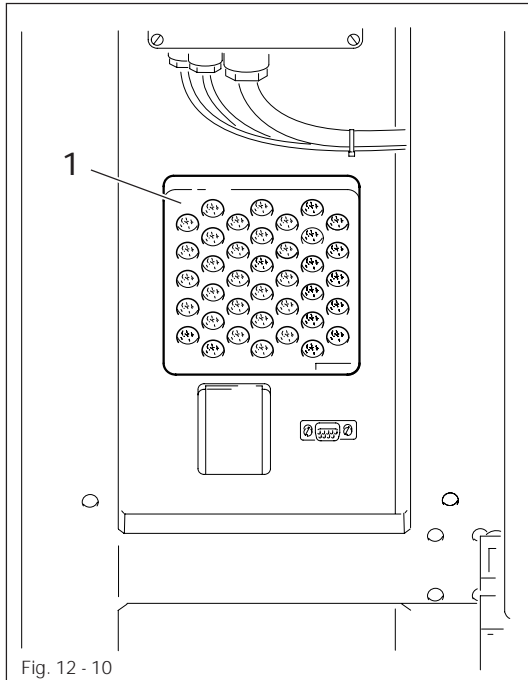

Cleaning the blower air filter at the base of the machine:



- Remove cover 1.
- Take out filter element and clean with compressed air.
- Insert filter element and replace cover 1.

Cleaning the blower air filter in the control box:



Before opening the control box, be sure to turn off the main switch and ensure that it cannot be switched back on accidentally!



- Open control box!
- Press inward on the catches 2 and open cover 3.
- Take out filter element and clean with compressed air.
- Insert filter element and replace cover 3.

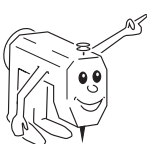

We recommend that you enter a record of each time the blower air filter is cleaned in the maintenance chart on the inside of the control box door.

12.07 Compressed air unit

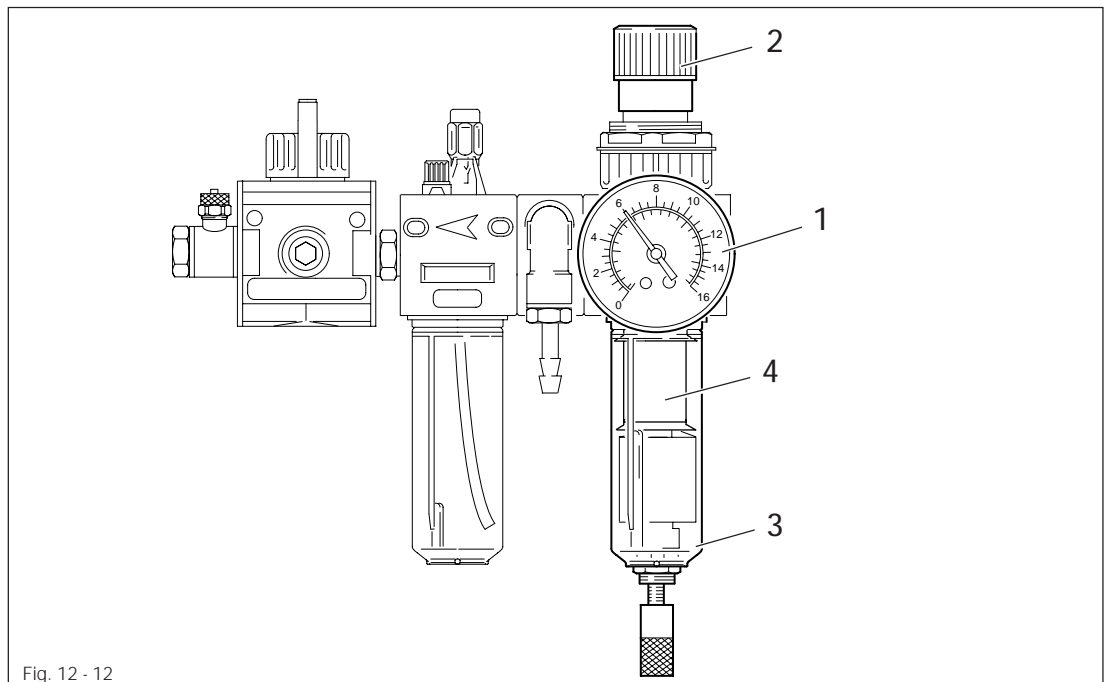

Fig. 12 - 12

12.07.01 Checking and regulating air compression

- Always check the air compression on the manometer 1 before operating the machine.



The manometer 1 must indicate a pressure of 6 bar.

When required:

- Pull up on knob 2 and turn so that the manometer 1 indicates a pressure of approx. 6 bar.

12.07.02 Cleaning the air filter



The air filter must be cleaned whenever the working pressure of 6 bar is no longer achieved.



Turn off compressed air!



- Unscrew drum 3.
- Remove filter element 4.
- Clean filter element 4 and drum 3 with benzine.
- Blast filter element 4 from the inside out with compressed air.
- When assembling, make sure that the seals are positioned properly.
- Open compressed air.

## 12.07.03 Checking and topping up the oil level

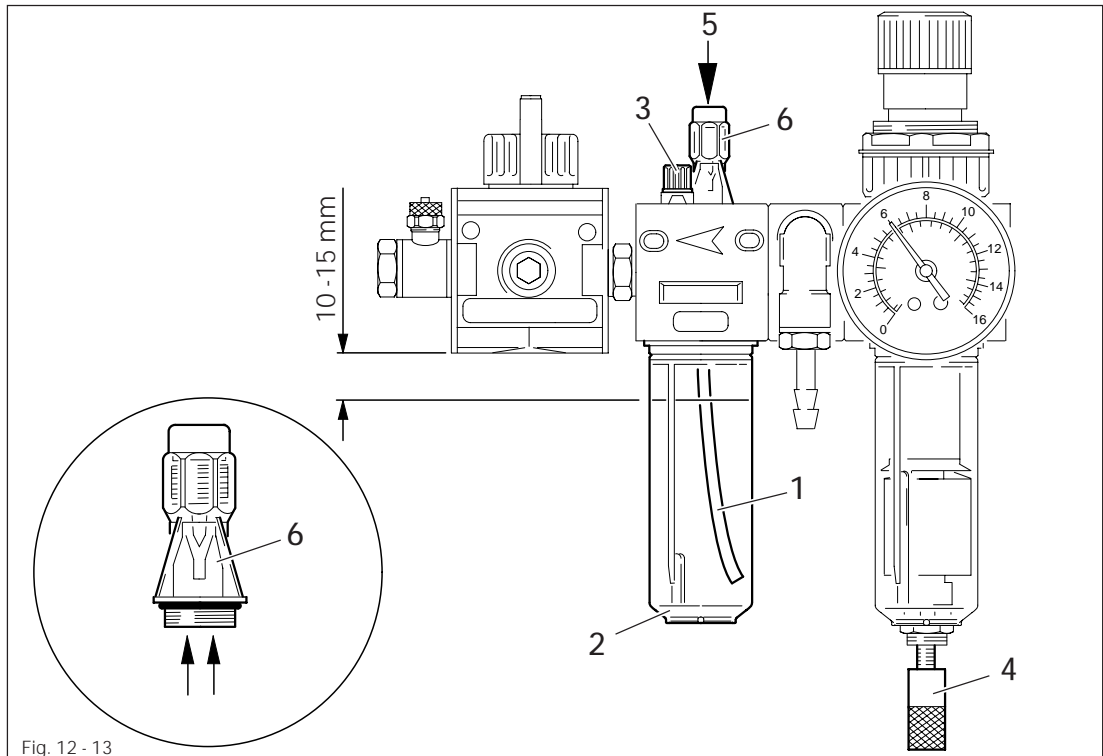

Fig. 12 - 13

- When operating the machine with lubricated air (see **chapter 9.02 Commissioning the machine**), always check the oil level in the compressed air unit before every use of the machine.



The suction tube **1** must always be immersed in oil.

If required:



Turn off compressed air!

- Check container **2** for contamination (residue).
- If required, unscrew container **2** and clean, e.g. with benzene.
- Screw container **2** back on. Observe the seal.
- Open screw **3** and fill oil into the container until the oil level is **10-15 mm** below the top of container **2**.
- Tighten screw **3** and open compressed air.



Only use pneumatic oil with a mean viscosity of 22.0 mm<sup>2</sup>/s to 46.0 mm<sup>2</sup>/s at 40°C and a density of 0.865 g/cm<sup>3</sup> to 0875 g/cm<sup>3</sup>.

The types of oil used must not cause the seal materials to swell or shrink more than a nominal amount under varying operating conditions.

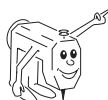

We recommend PFAFF sewing machine oil. Part no. 280-1-120 144.

### 12.07.04 Emptying the water trap



Make sure that the knurled bush **4** is unscrewed as far as it will go (left-hand thread).



When the water level rises, the automatic drain opens and the water is drained off.

- Place a suitable container under the drain opening.

### 12.07.05 Adjusting the drip feed rate on the oil vaporizer



This adjustment is not required when the machine is not operated with lubricated air.

- Adjust regulating screw **5** so that adequate lubrication of the cylinders and valves is guaranteed (1 drop per 30 work cycles).

### 12.07.06 Cleaning the vaporizer jet



Turn off the compressed air.



- Unscrew regulating screw **5** as far as possible.
- Unscrew vaporizer jet **6** and blast with compressed air in the direction of the arrow.
- Observe the seal when putting back together.
- Open compressed air and readjust drip feed rate.

## 13 Adjustment



Before beginning any adjustment work, observe all relevant safety regulations!

### 13.01 Notes on adjustments

All adjustments in these adjustment instructions are based on a completely assembled machine. Covers on the machine which have to be removed for checks and adjustment work and later remounted are not mentioned. The screws or nuts in () are for securing machine parts and must be loosened before the adjustment and retightened after all adjustments are carried out.

### 13.02 Tools, gauges and other accessories

- 1 set of screwdrivers with blade widths from 2 to 10 mm
- 1 set of wrenches with jaw widths from 6 to 22 mm
- 1 set of Allan keys from 1.5 to 6 mm
- 1 universal screwdriver with interchangeable blades
- 1 adjustable wrench
- 1 250g hammer
- 1 circlip pliers for circlips (Seeger circlip ring pliers)
- 1 pair of tweezers (slanted)
- 1 metal rule (0.3 mm thick)
- 1 brass arbor ( 8 mm dia., 250 mm in length)
- 1 adjustment pin (5 mm diameter), Part No. 13-030 341-05
- 1 hook bearing adjustment gauge, Part No. 91-129 996-01
- 1 adjustment pin (zero point adjustment)
- 1 edge guide (800 - 1000 mm in length)
- 1 bottle of Loctite
- Sewing thread and test material

### 13.03 Abbreviations

TDC = top dead center

BDC = bottom dead center

## 13.04 Removing/inserting sewing machine head



Turn off compressed air.

Switch off main switch and ensure that it cannot be turned back on accidentally.

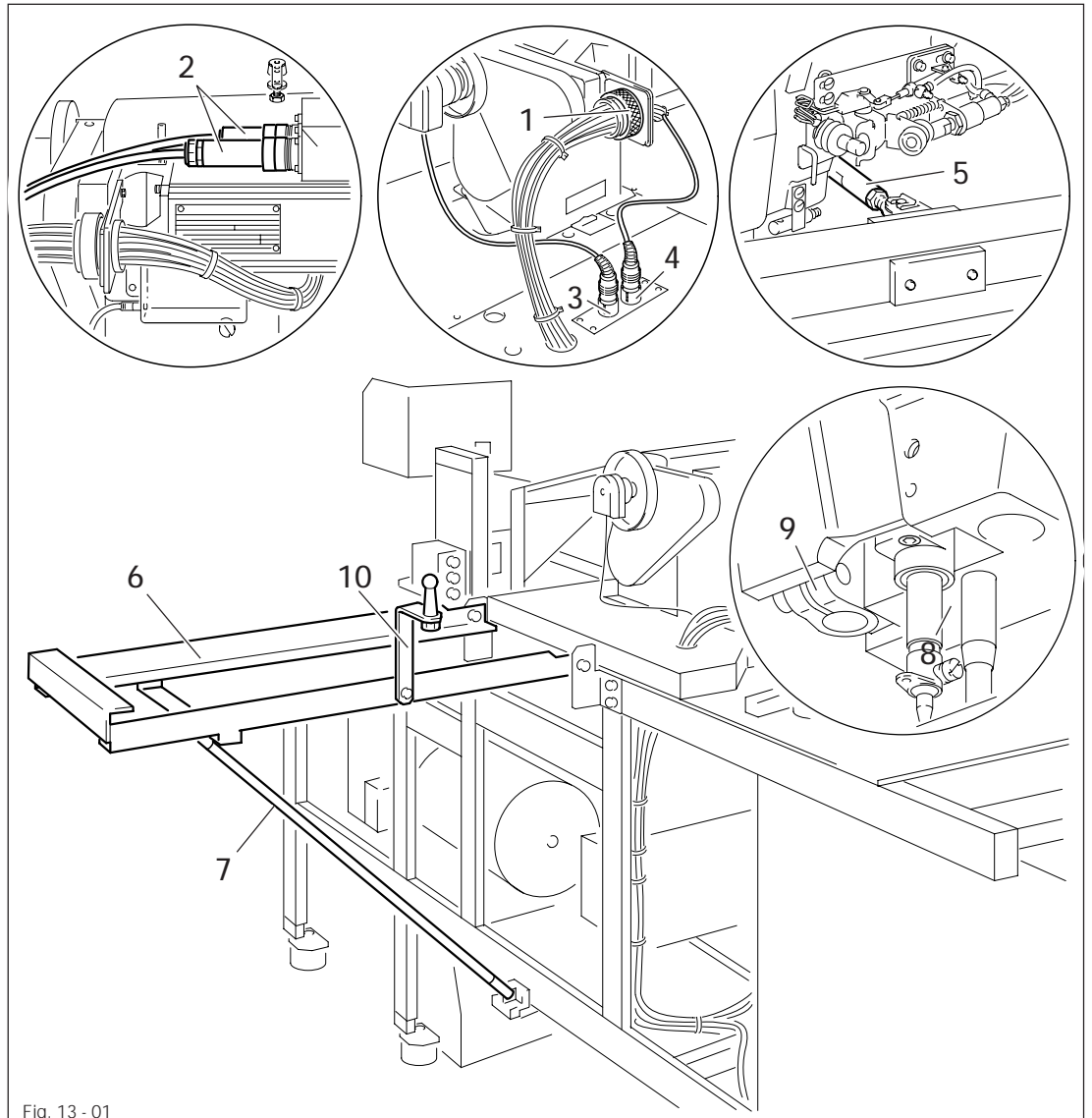
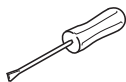

Fig. 13 - 01



- When **removing**, unplug pneumatic power supply (knurled bush 1).
- Fold down bar and disconnect plug 2.
- Unplug plugs 3 and 4.
- Disconnect pull rod 5 on transport arm.
- Position frame 6 horizontally and connect support 7.
- Remove split pin 8 and push down lever 9.
- Remove sewing machine head.
- For work beneath the bedplate, raise support 10 and tilt back sewing machine. Make sure that the rounded end on support 10 engages in the ball pin of the sewing machine.
- To **insert** the machine head, carry out the steps above in reverse.
- Ensure that after the machine head is tilted upright lever 9 is secured with the split pin 8.

## 13.05 Checking and adjustment aids



By blocking holes 1-4, the required needle bars positions can be fixed precisely.

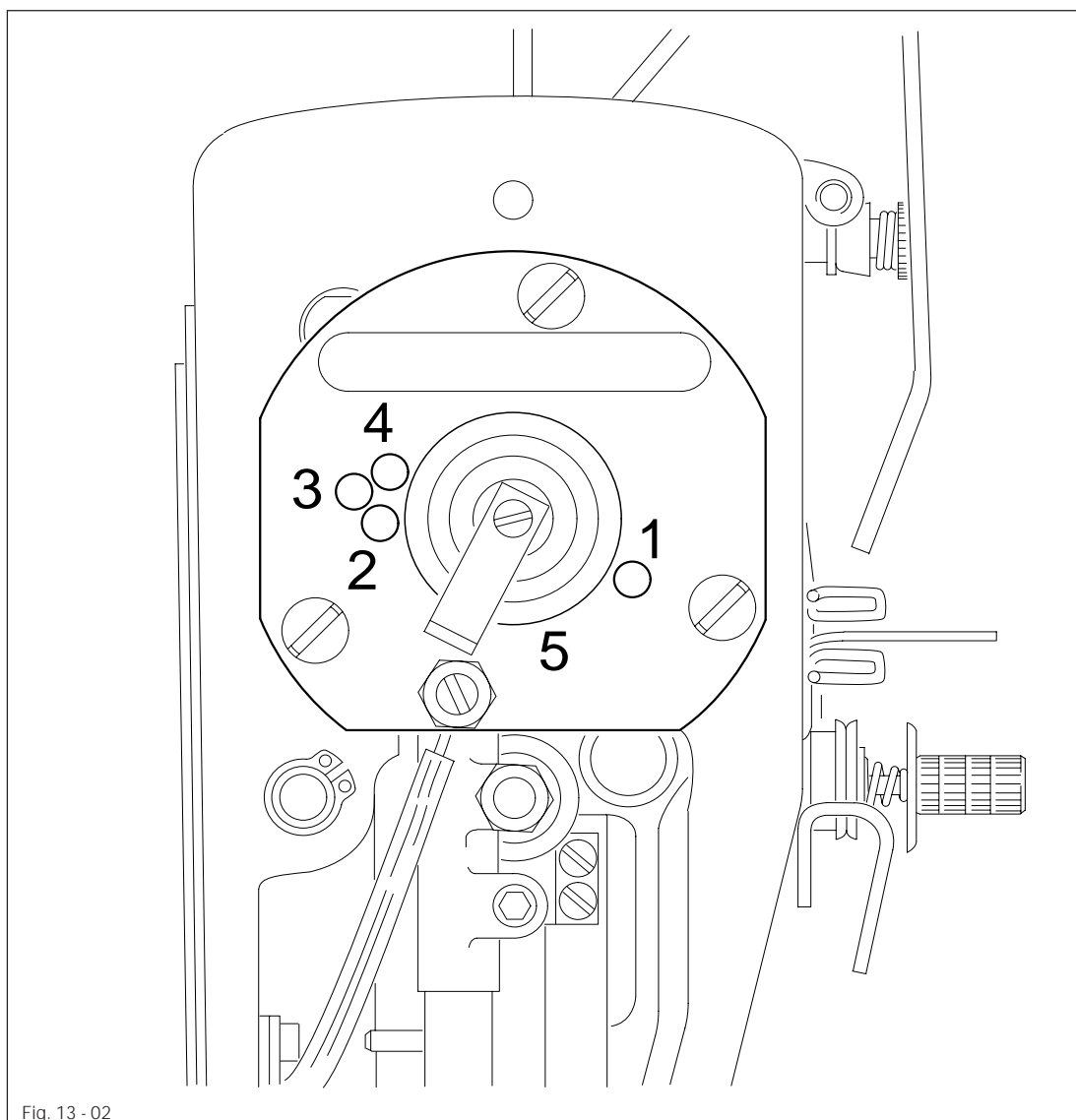
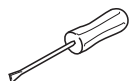

Fig. 13 - 02



- Turn the handwheel until the needle bar is in approximately the required position.
- Place the adjustment pin in the appropriate hole and apply pressure.
- Rotate the handwheel back and forth slightly until the adjustment pin engages in the crank slot behind the bearing plate, thus blocking the machine.

Hole 1	=	2.4 mm past the bottom dead center of the needle bar (2.4 past BDC)
Hole 2	=	top dead center of the needle bar (TDC)
Hole 3	=	0.25 mm past the top dead center of the needle bar (0.25 past TDC)
Hole 4	=	1.0 mm past the top dead center of the needle bar (1.0 past TDC)



## 13.06 Adjusting the sewing machine head

## 13.06.01 Counterweight

**Requirement**

In needle bar position BDC the largest eccentricity of the counterweight 1 must be at the top.

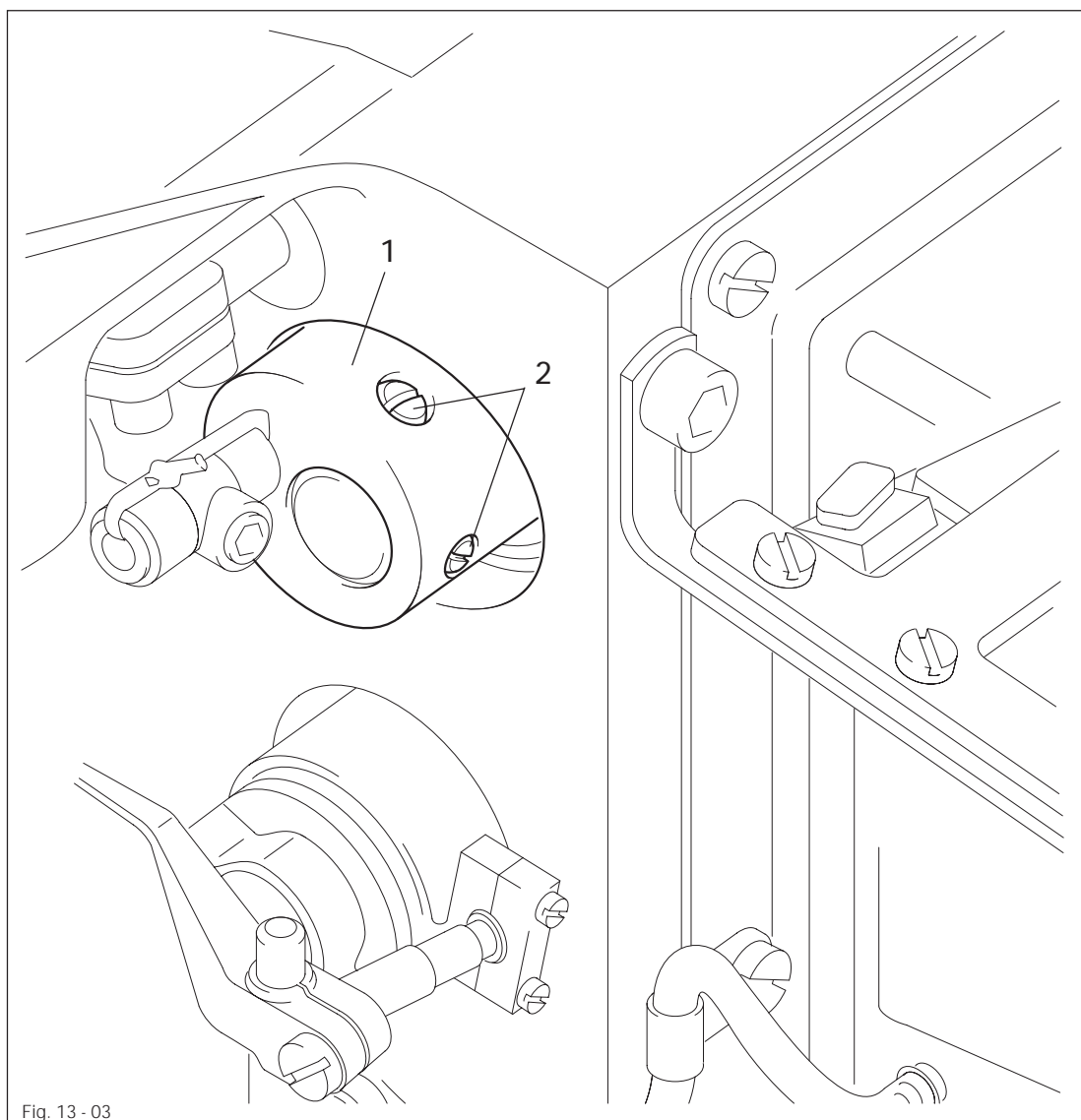
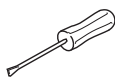

Fig. 13 - 03



- Move needle bar to BDC.
- Turn counterweight 1 (screws 2) according to the **requirement**.

## 13.06.02 Centering the needle in the needle hole (in the direction of sewing)

### Requirement

In straight stitch position, viewed in the direction of sewing, the needle must be centered in the needle hole in the hook bearing adjustment gauge 4.

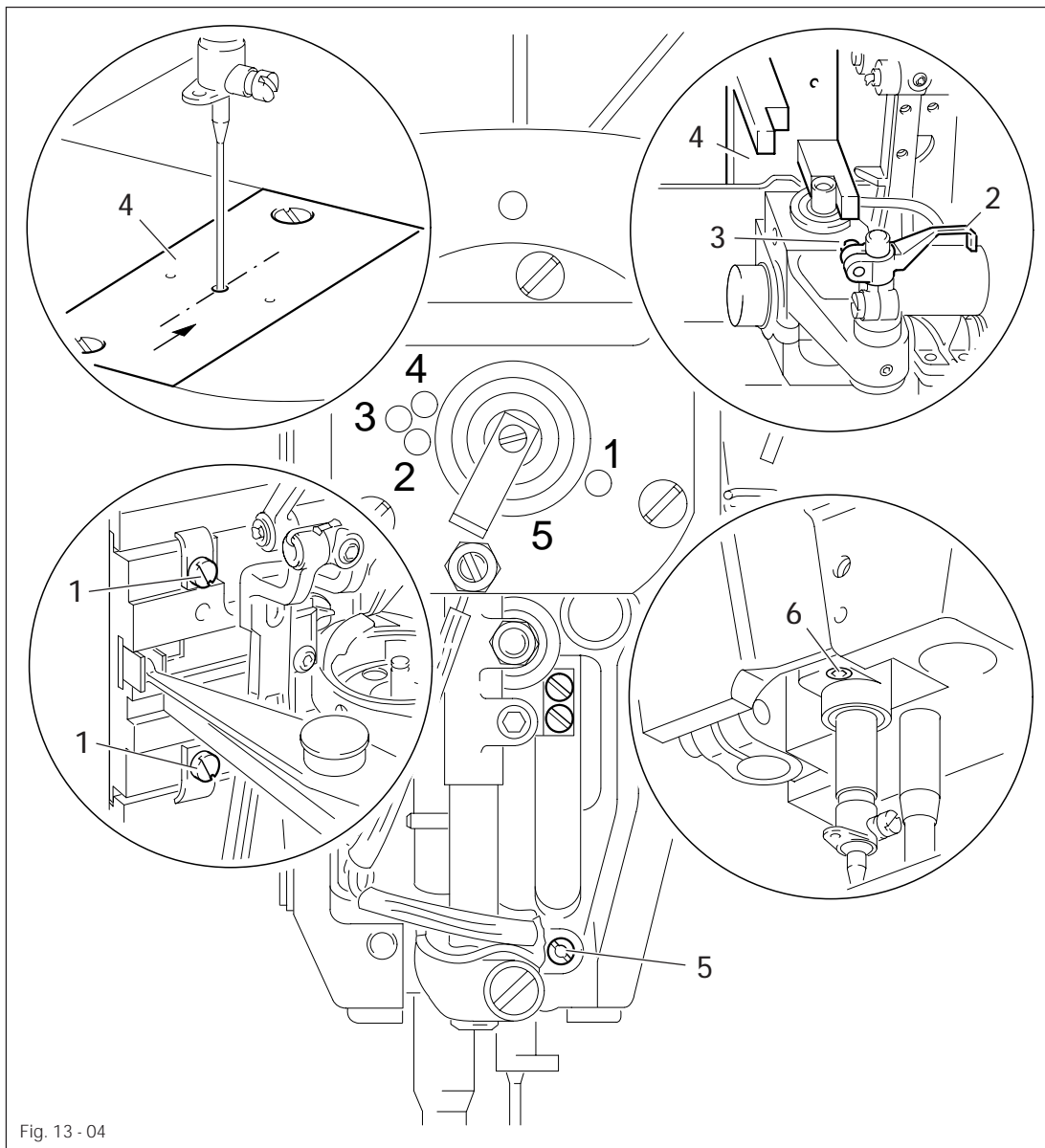
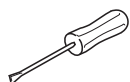

Fig. 13 - 04



- Unscrew counter presser and needle guard.
- Insert a new needle.
- Loosen screws 1 and remove thread trimmer unit.
- Swing bobbin opener 2 (screw 3) to the right and remove hook.
- Fit hook bearing adjustment gauge 4 so that the numbers "418 - 419" can be read from the right. Bring needle bar to BDC.
- Turn eccentric pin 5 (screw 6) according to the **requirement**.



The hook bearing adjustment gauge 4 remains fitted for further adjustments.

## 13.06.03 Needle bar-parallel guide

**Requirement**

The guide rod 5 must be parallel to the needle bar.

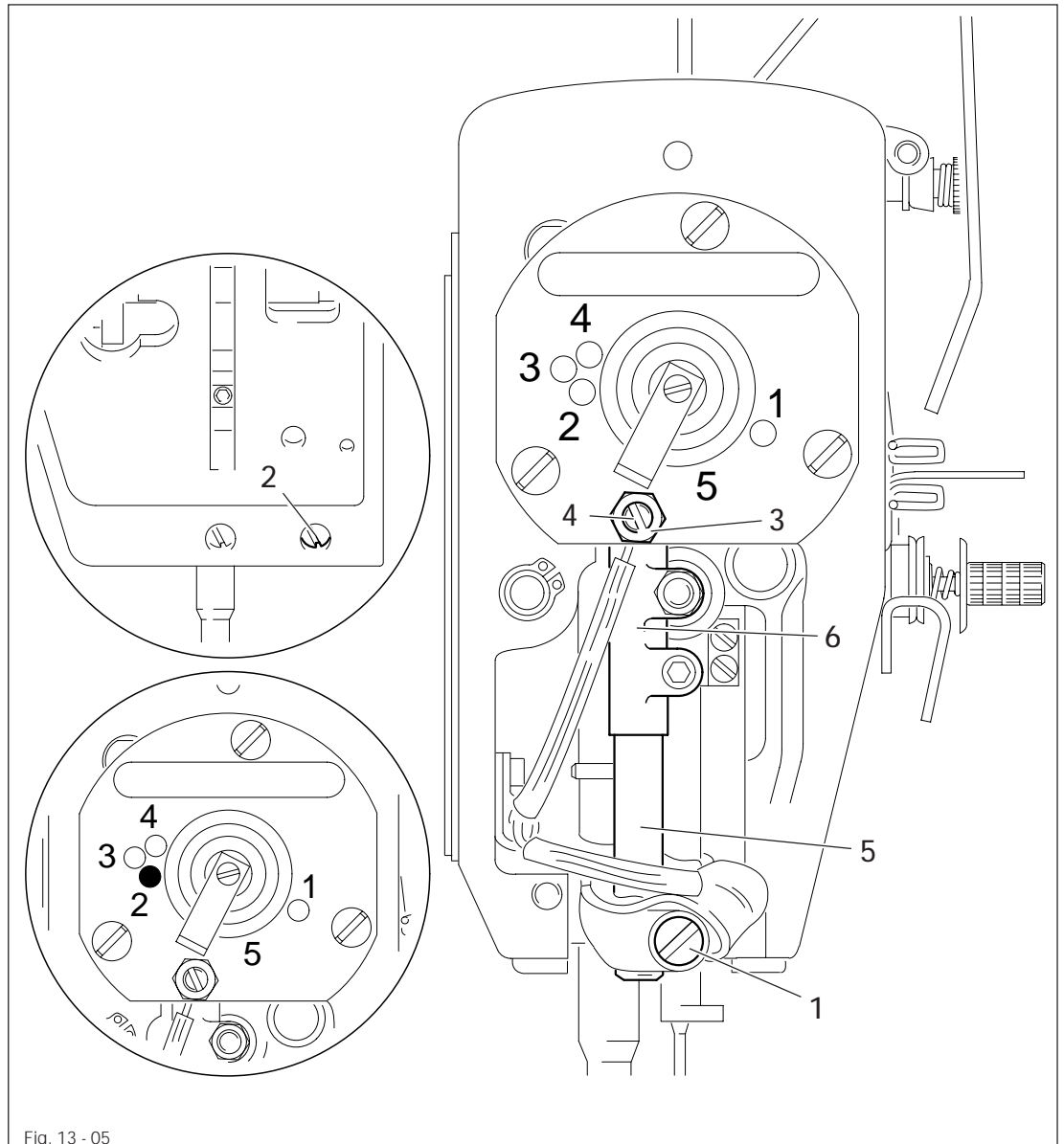
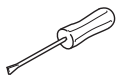

Fig. 13 - 05



- Move needle bar to TDC (hole 2).
- Loosen screws 1, 2 and nut 3.
- Position the greatest eccentricity of pin 4 toward the bottom.
- Move the recess of the guide bar 5 against the eccentric pin 4.
- Turn eccentric pin 4 according to the **requirement** and tighten nut 3.
- Push guide rod 5 down and then up as far as it will go, making sure that the bush 6 does not move sideways (if necessary, readjust eccentric pin 4).
- Move guide rod 5 against the eccentric pin 4 as far as it will go and tighten screws 1 and 2.

## 13.06.04 Setting zero stitch

### Requirement

In straight stitch position (cylinder plunger fully retracted), the needle bar must not carry out a zigzag movement when the handwheel is turned.

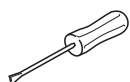
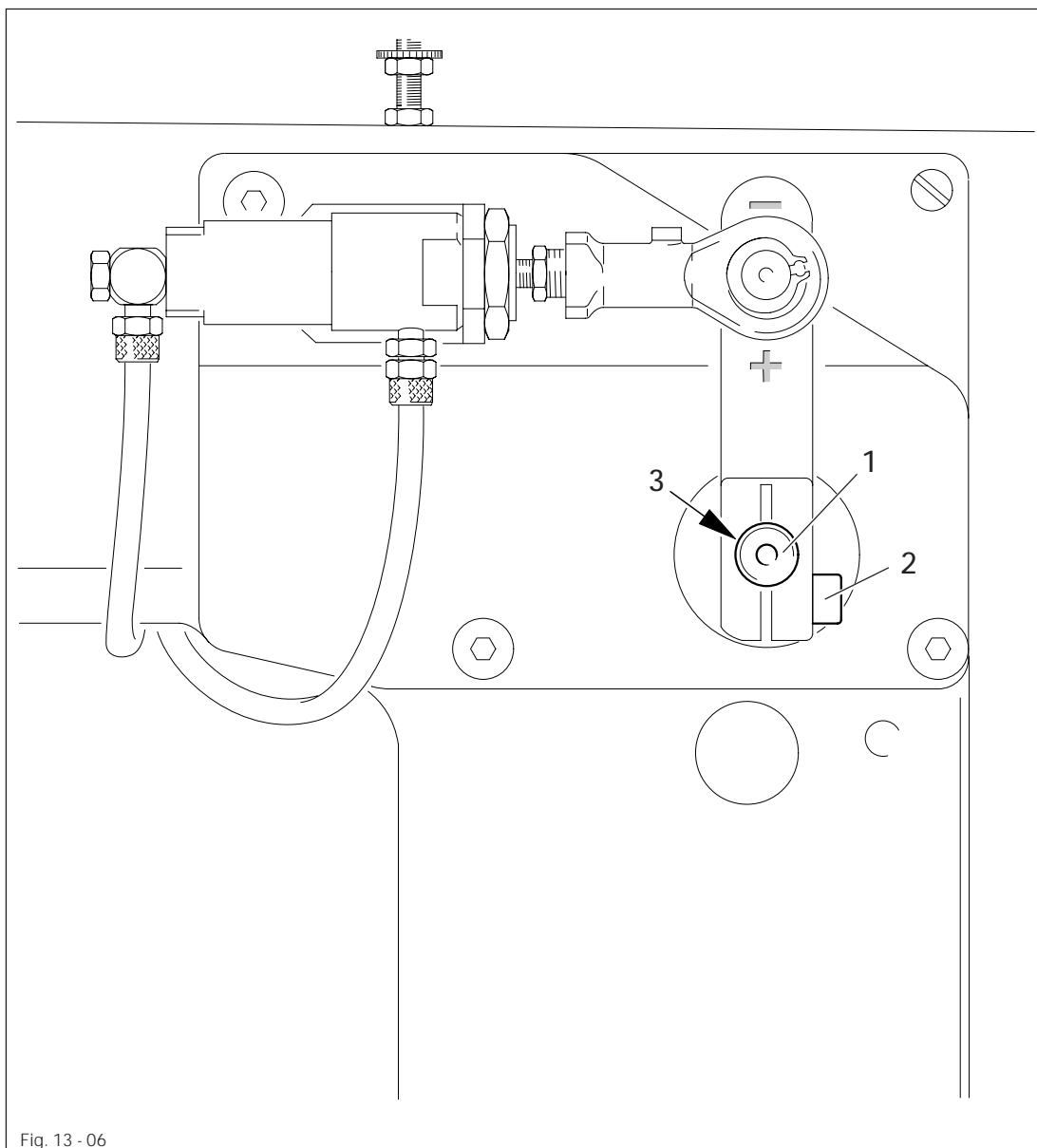

- Place a piece of paper over the needle plate cutout and, by turning the handwheel, perforate with the needle.
- Turn handwheel backwards until the paper is perforated again.
- Both perforations must be congruent. Otherwise, turn the regulator shaft 1 (screw 2) according to the **requirement**.



In order to turn the regulator shaft 1, insert a pin in the hole 3.

## 13.06.05 Zigzag stitch movement

**Requirement**

When the needle, coming from the right point of needle entry, is in TDC (hole 2), the needle bar must not move when the zigzag stitch width regulator is operated.

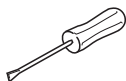
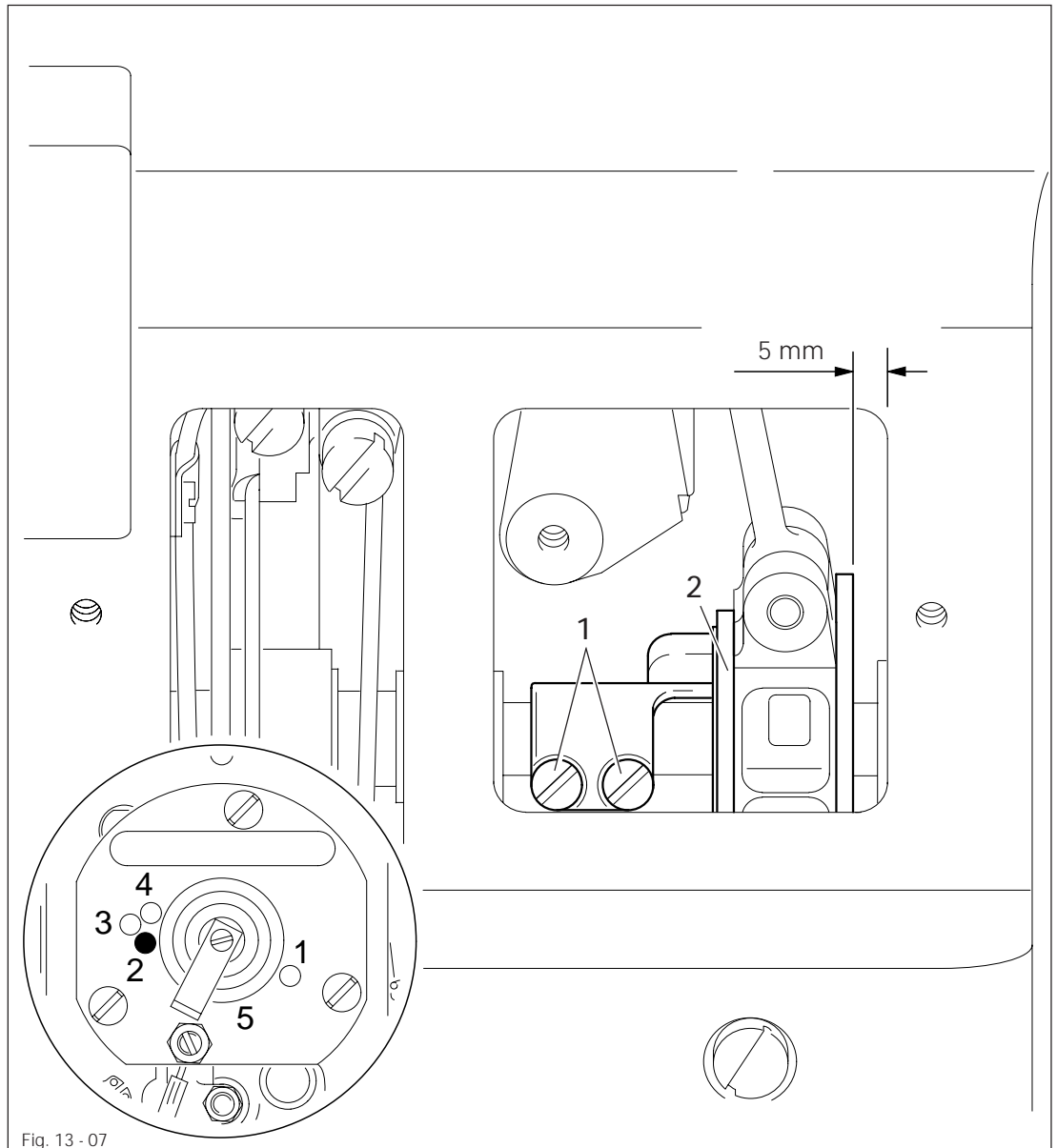

- Loosen screws 1 slightly.
- Bring needle bar to TDC (hole 2).
- Move eccentric 2 until the distance from it to the right inner side of the housing is approx. 5 mm.
- Turn eccentric 2 according to the requirement and tighten screws 1.

## 13.06.06 Needle penetration symmetry

### Requirement

1. In straight stitch position, the needle must penetrate exactly the center of the needle hole.
2. For the largest zigzag stitch setting, the point of needle penetration to the right and left must be at the same distance to the center point of needle penetration.

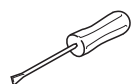
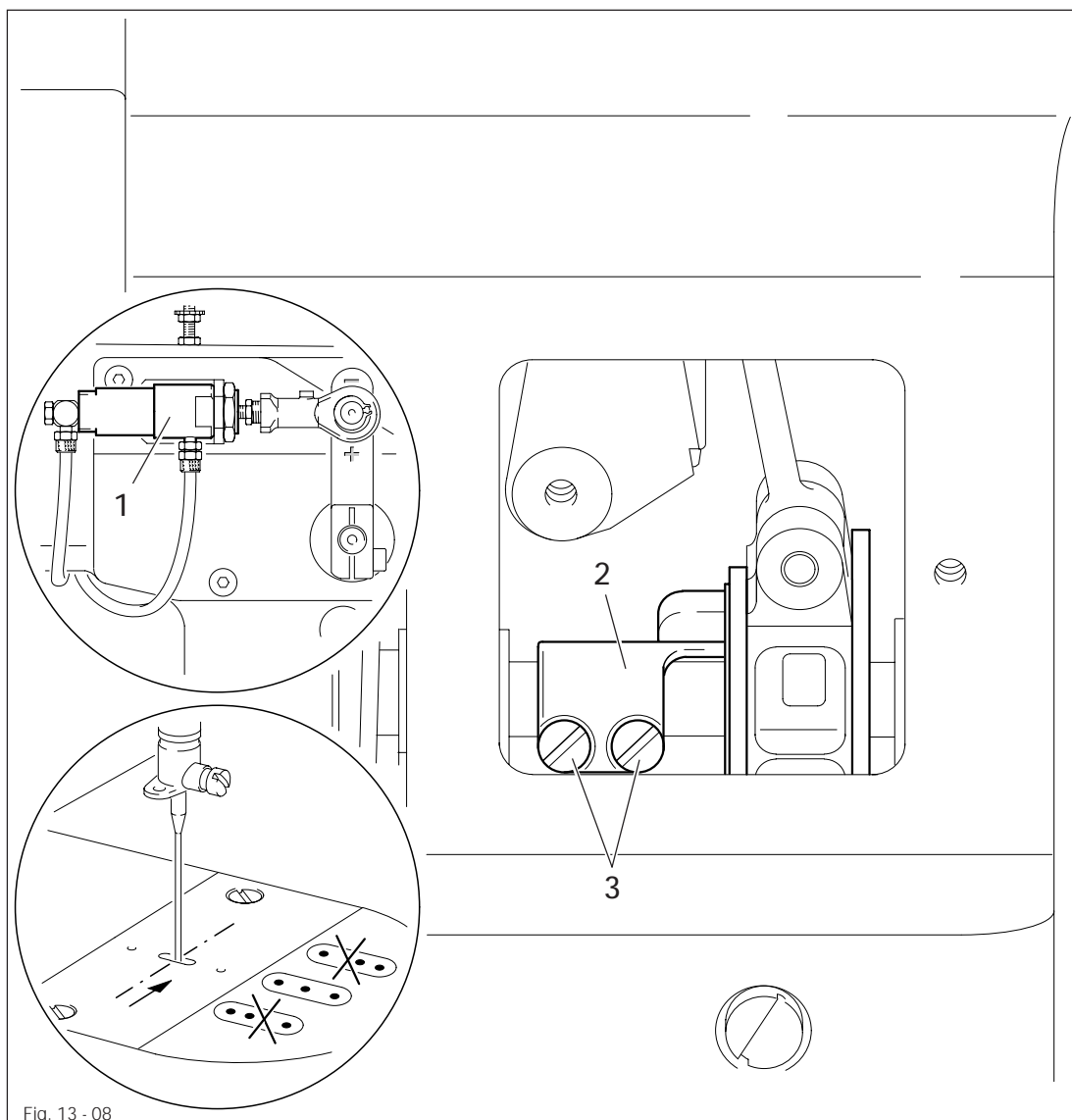

- Fully retract the plunger of the cylinder 1.
- Place a piece of paper under the needle and perforate it.
- Turn so that the needle moves up somewhat and extend the plunger of cylinder 1 fully.
- Perforate the paper left and right by turning the handwheel forward and backward.
- Move eccentric 2 sideways (screws 3) according to the requirement.
- Check adjustment in **chapter 13.06.02 Centering the needle in the needle hole (in the direction of sewing)**, and adjust if required.

## 13.06.07 Centering the needle in the needle hole (across the direction of sewing)

### Requirement

In straight stitch position, viewed across the direction of sewing, the needle must be centered exactly in the needle hole in the hook bearing adjustment gauge.

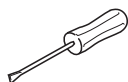
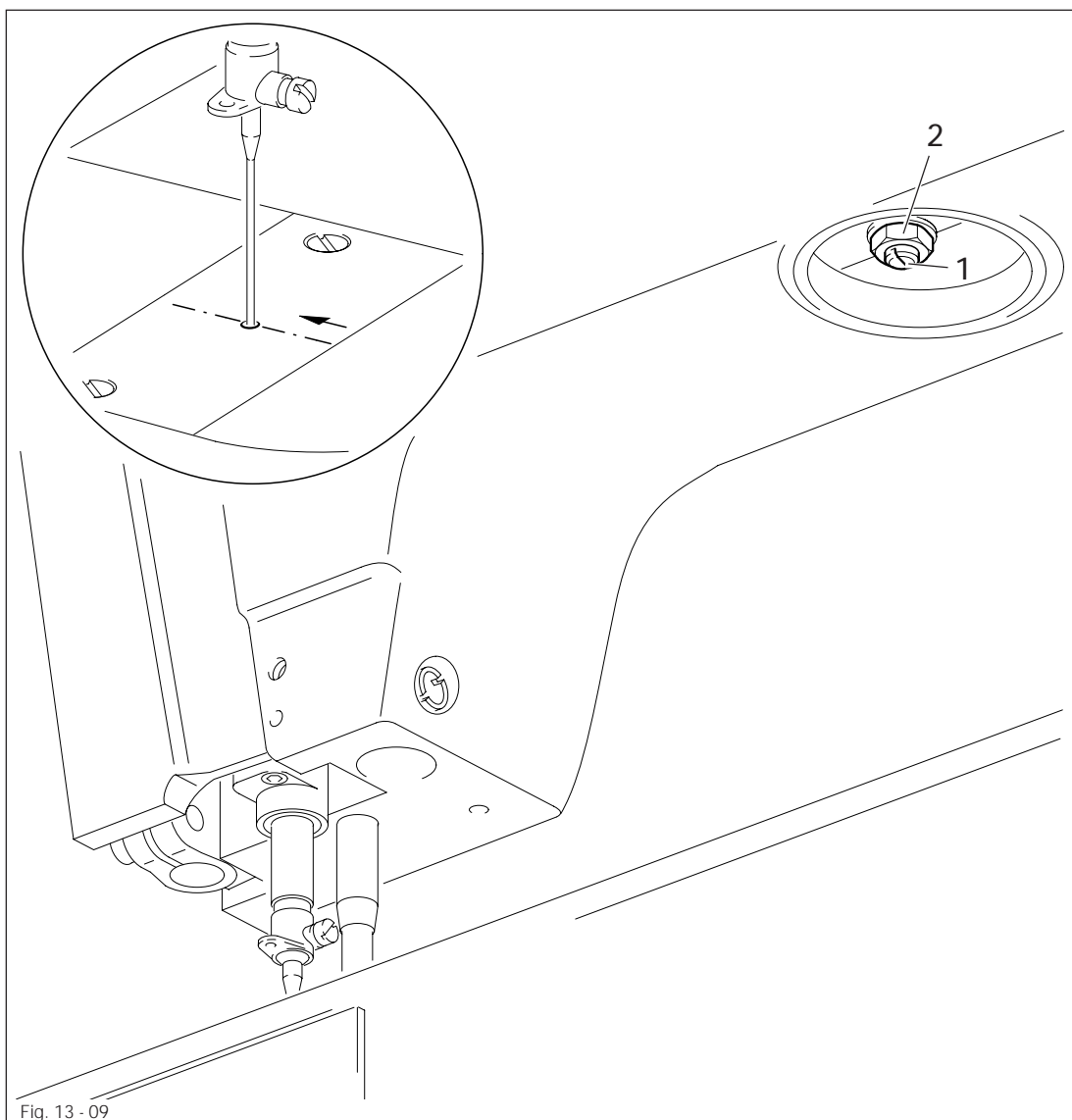

- Bring needle bar to BDC.
- Turn eccentric pin 1 (nut 2) according to the requirement.

## Adjustment

### 13.06.08 Zigzag stitch width

#### Requirement

At the maximum zigzag stitch width, the needle must not strike against the counter presser.

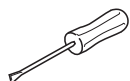
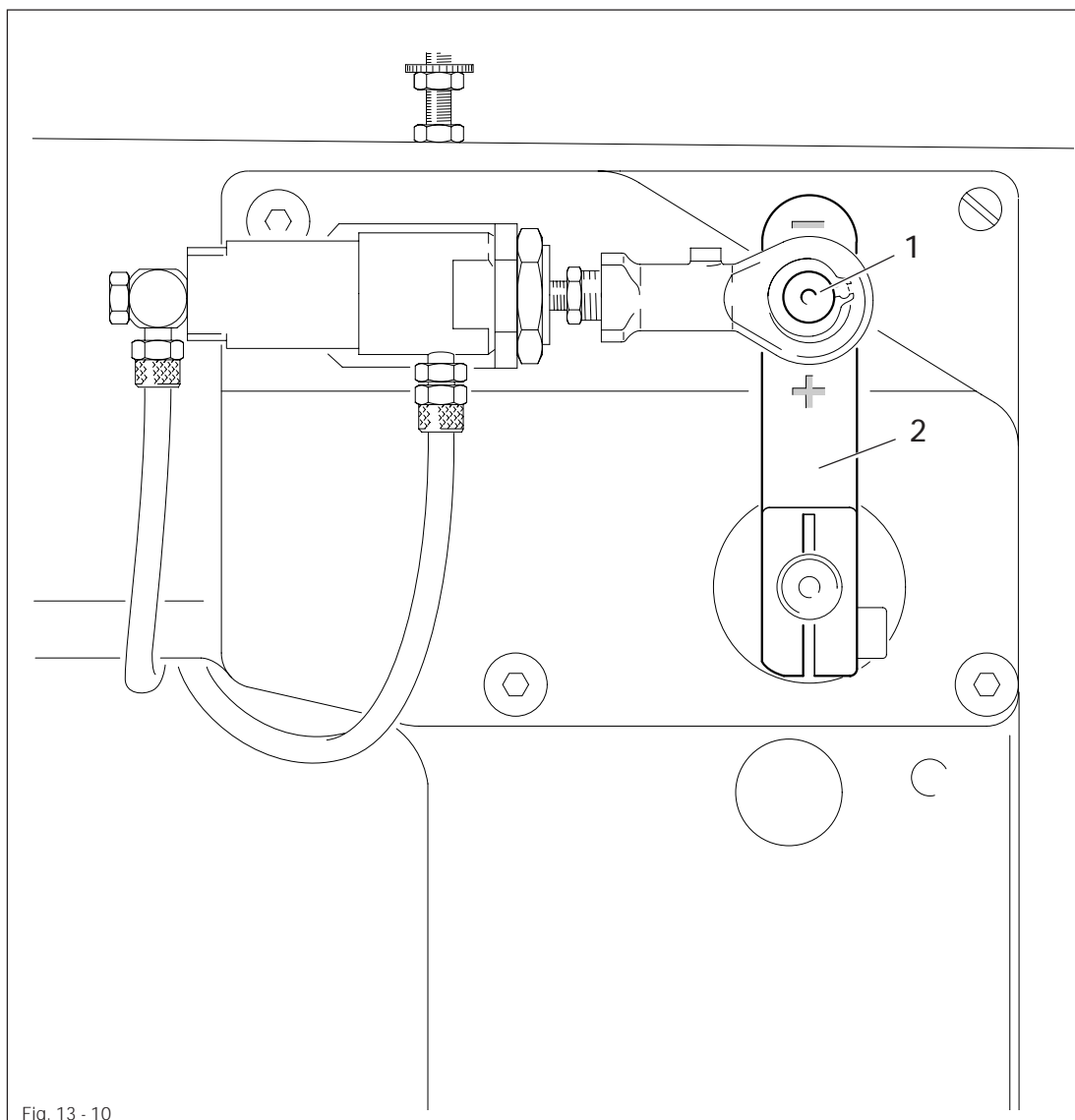

- Loosen the lock nut of pin 1.
- Slide pin 1 according to the **requirement** into the elongated hole of the lever 2.



By moving the pin 1 down (+), the zigzag stitch width is increased; by moving it up (-), it is decreased.



## 13.06.09 Hook bearing

**Requirement**

The hook shaft must rest against the hook bearing adjustment gauge 4 at the top and from the side.

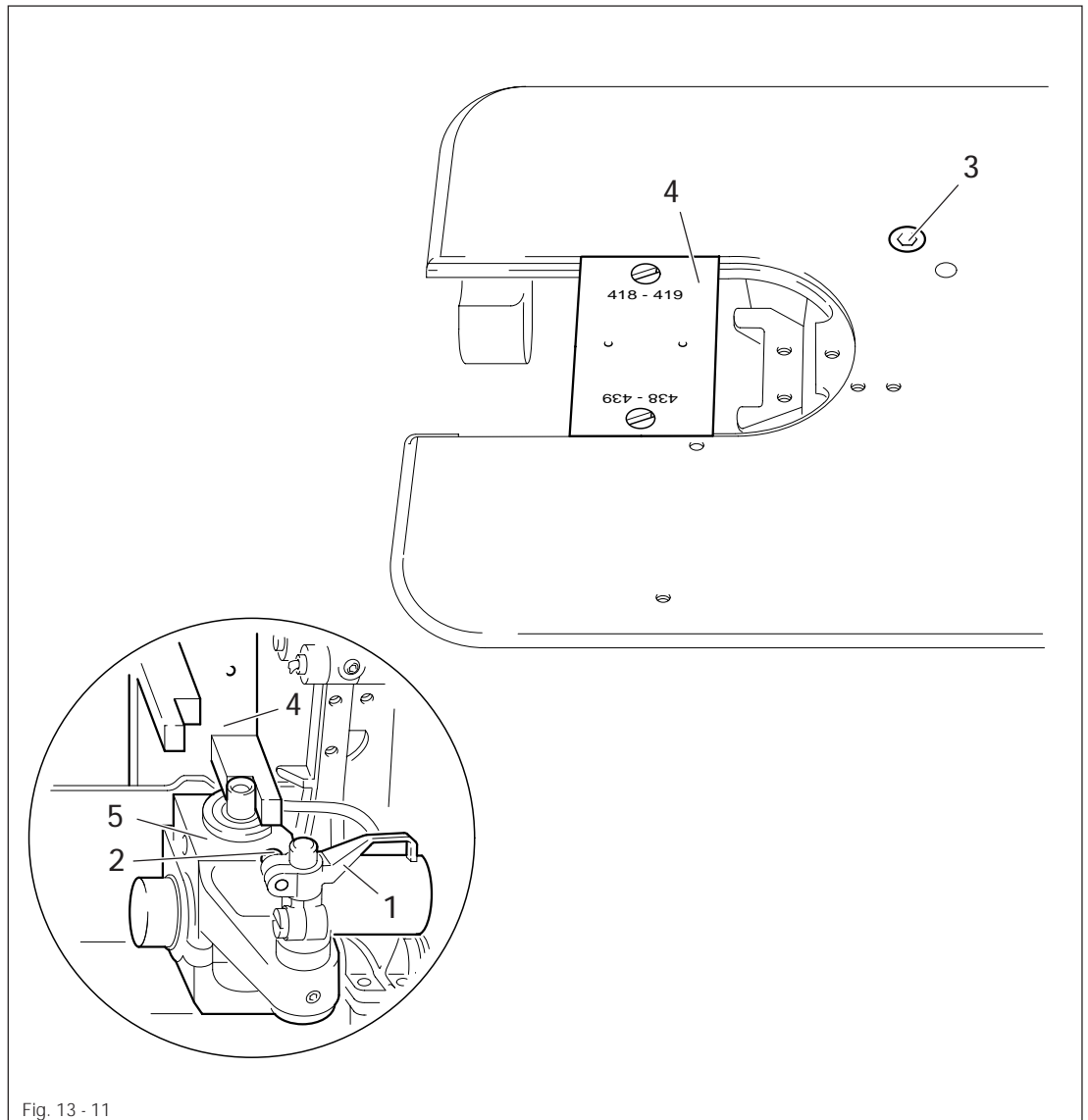
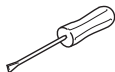

Fig. 13 - 11



- Loosen screw 3 and loosen the draw key under the screw head by tapping the screw head lightly.
- Move and/or turn the hook bearing 5 according to the requirement.
- Tighten screw 3.
- Unscrew hook bearing adjustment gauge 4.

### Requirement

1. The centrifugal washer **1** must be **1.5 mm** above the oil ring **3**.
2. When the machine is running at full speed, there should be a fine line of oil after approx. **10 seconds** on a paper strip held over the needle plate cutout.

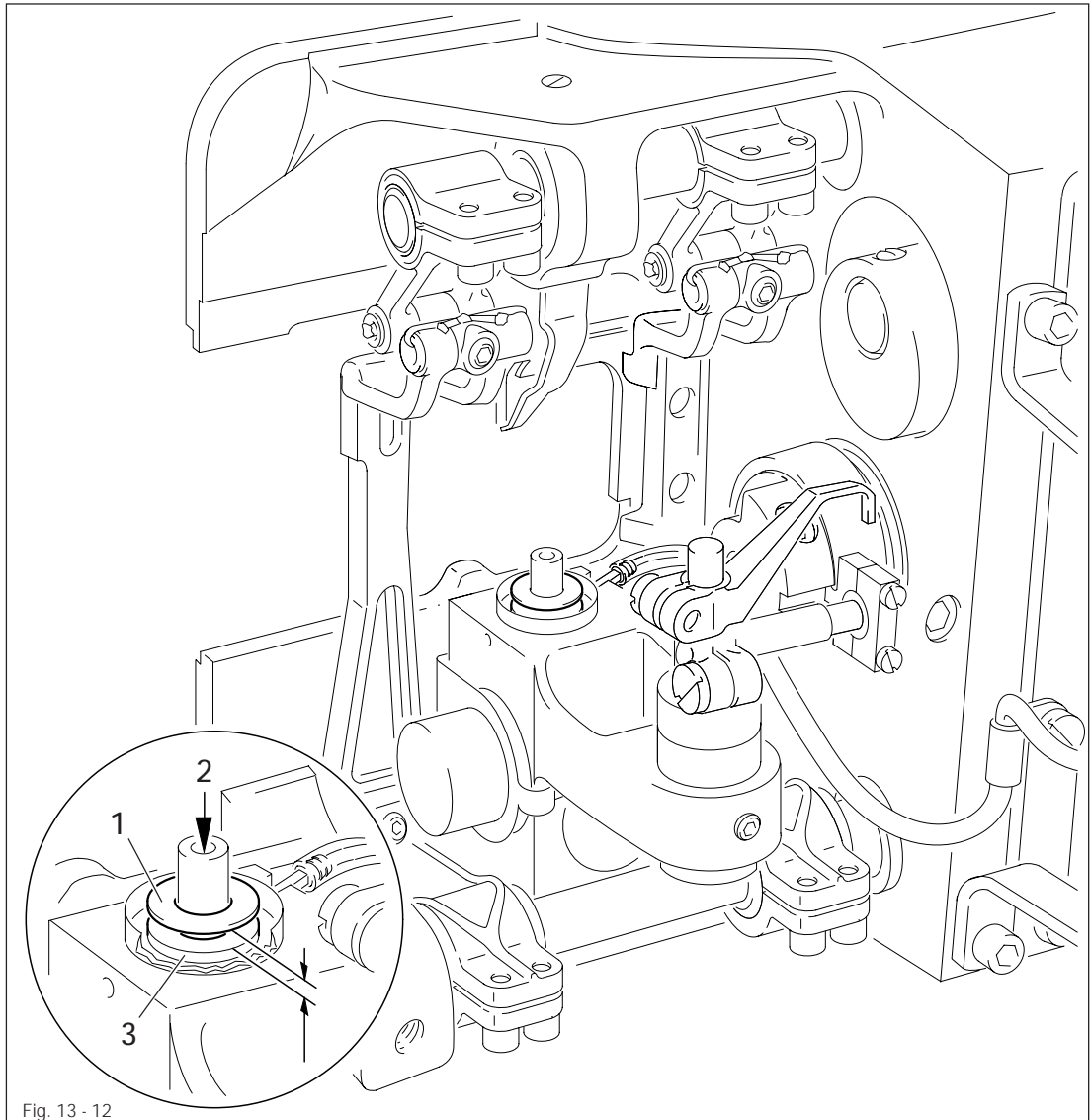

The adjustment is only required when the wick is replaced. After replacing the wick, make sure that the new one is impregnated with oil.

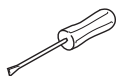

- Move centrifugal washer **1** (screw **2**) according to **requirement 1**.
- Check **requirement 2**; if necessary, move centrifugal washer **1**.

## 13.06.11 Gear box drive belt

### Requirement

The drive belt **3** must be tensioned so that the machine does not bind and the gears do not have any play.

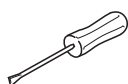
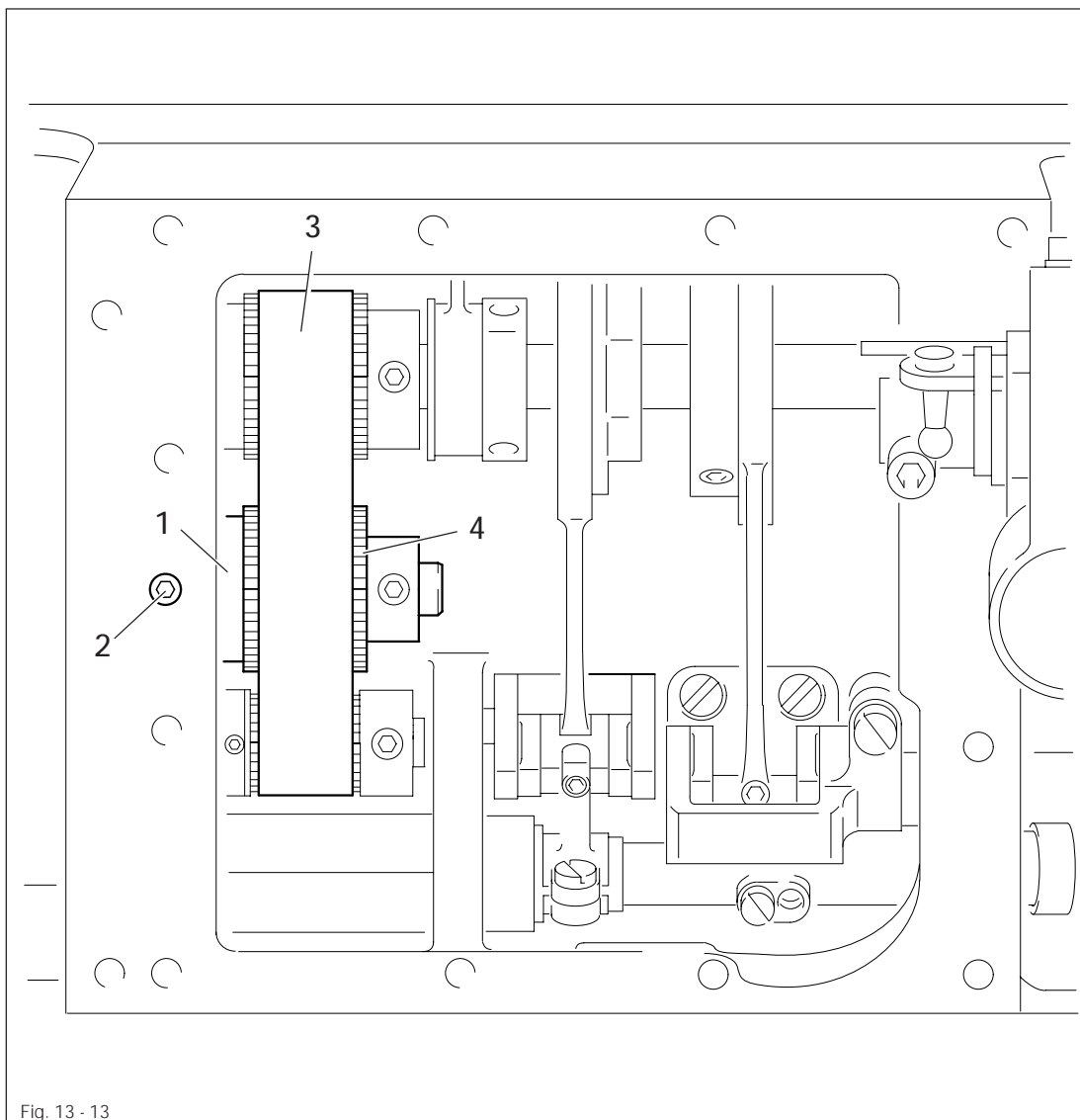

- Move eccentric bearing bush **1** (screw **2**) so that the drive belt **3** is positioned in the middle of the bobbin case opener's drive wheel **4** and turn out of position according to the **requirement**.

# Adjustment

## 13.06.12 Preadjusting the needle height

### Requirement

At needle bar position TDC (hole 2), the distance between the needle point and the needle plate must be approx. 19 mm.

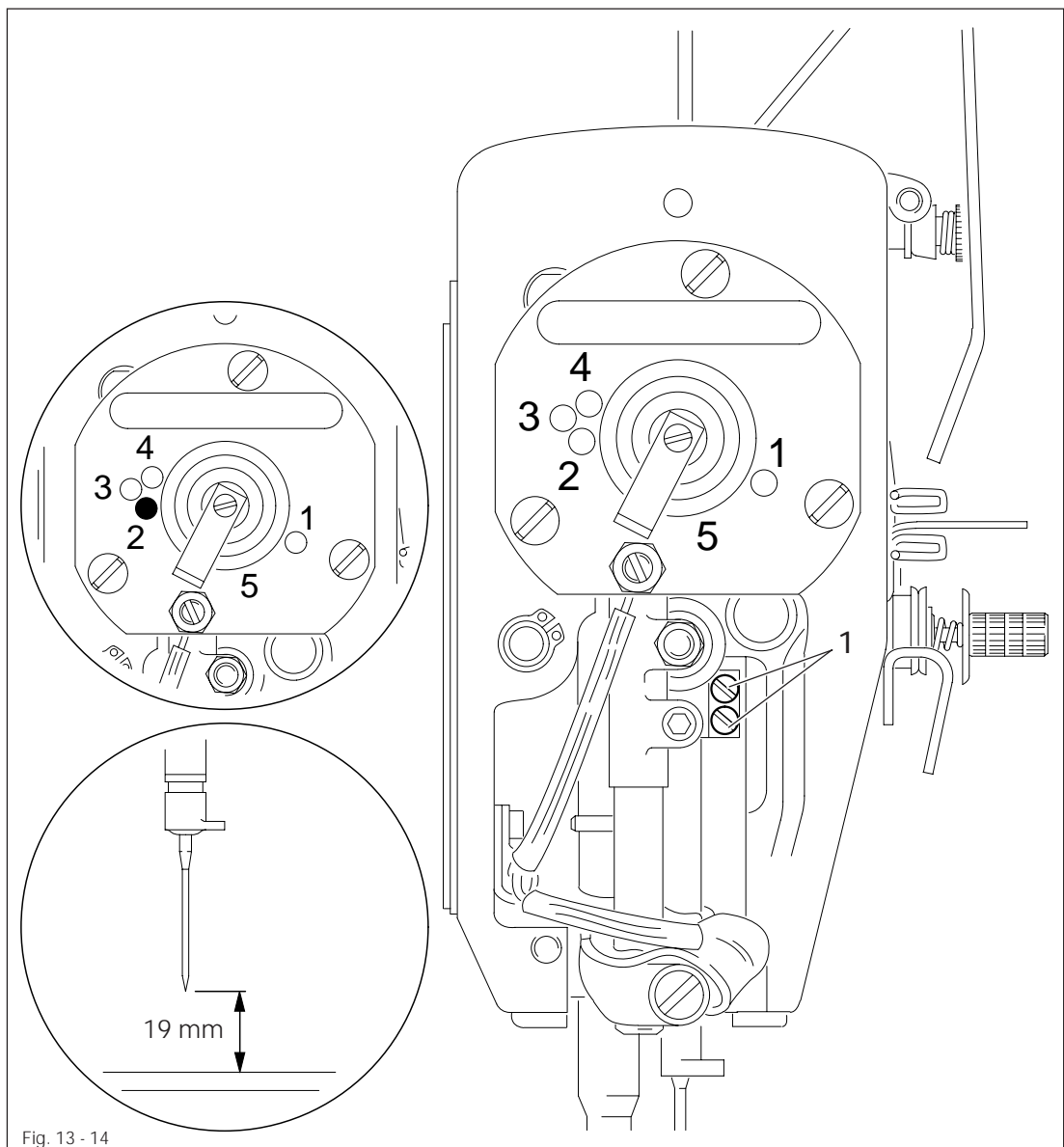
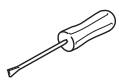

Fig. 13 - 14



- Move needle bar (screws 1) without twisting it according to the **requirement**.

## 13.06.13 Needle bar rise, hook-to-needle clearance and bobbin case position stop

**Requirement**

1. With the needle bar 2.4 past BDC (hole 1), the hook point must be at the middle of the needle; the distance between the needle and the hook point must be from **0.05 to 0.1 mm**.
2. The bobbin case position stop is to be mounted so that between the bobbin case base and the front edge of the bobbin case position stop there is a distance of **1.0 mm** (see arrow).

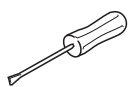
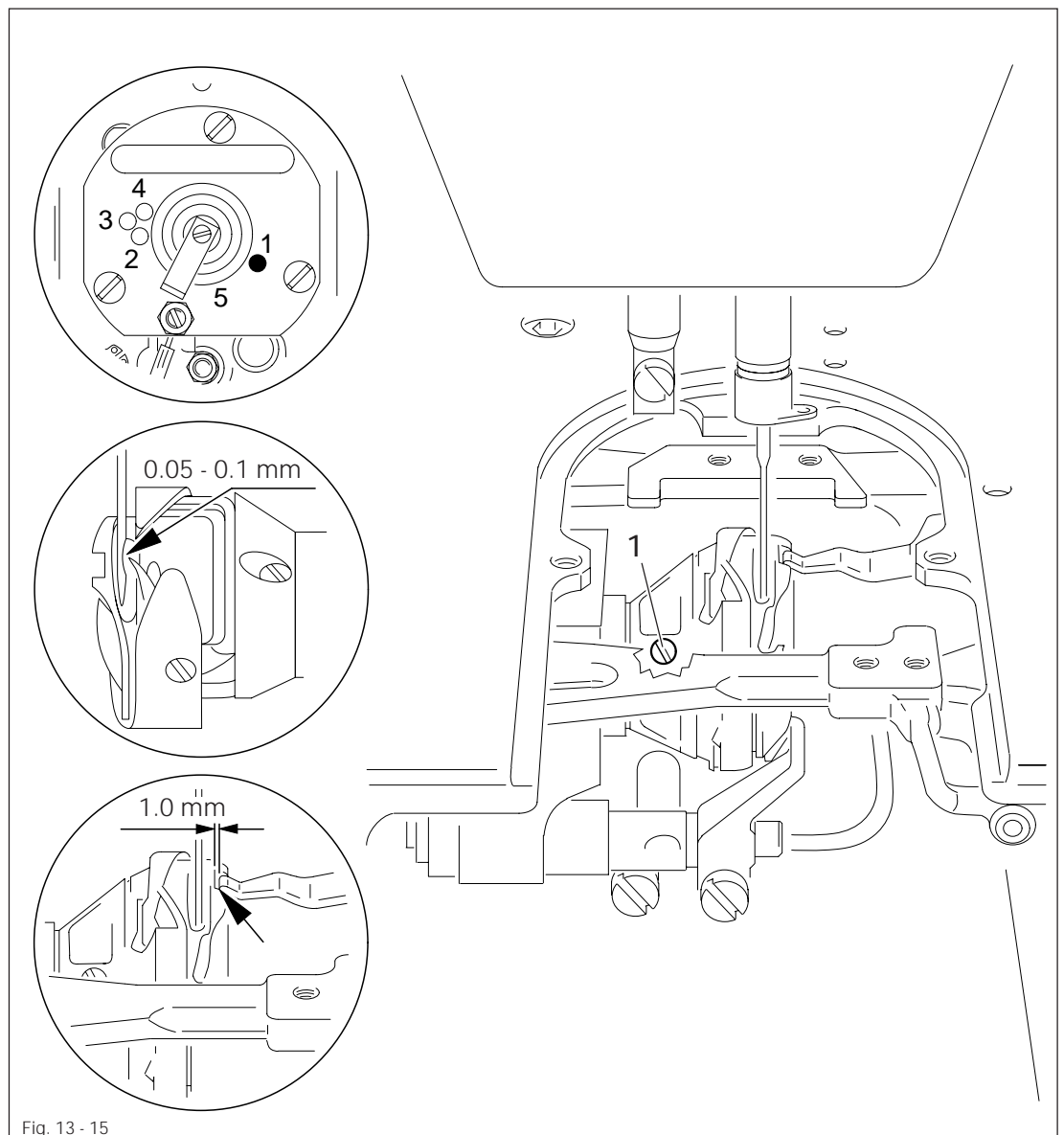

- Adjust the hook (screw 1) according to **requirement 1**.
- Mount bobbin case position stop according to **requirement 2**.

# Adjustment

## 13.06.14 Final adjustment of needle height

### Requirement

When, in the left-hand zigzag position, the hook point is at the center of the needle, the upper edge of the needle eye must be **0.5 mm** below the hook point.

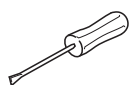
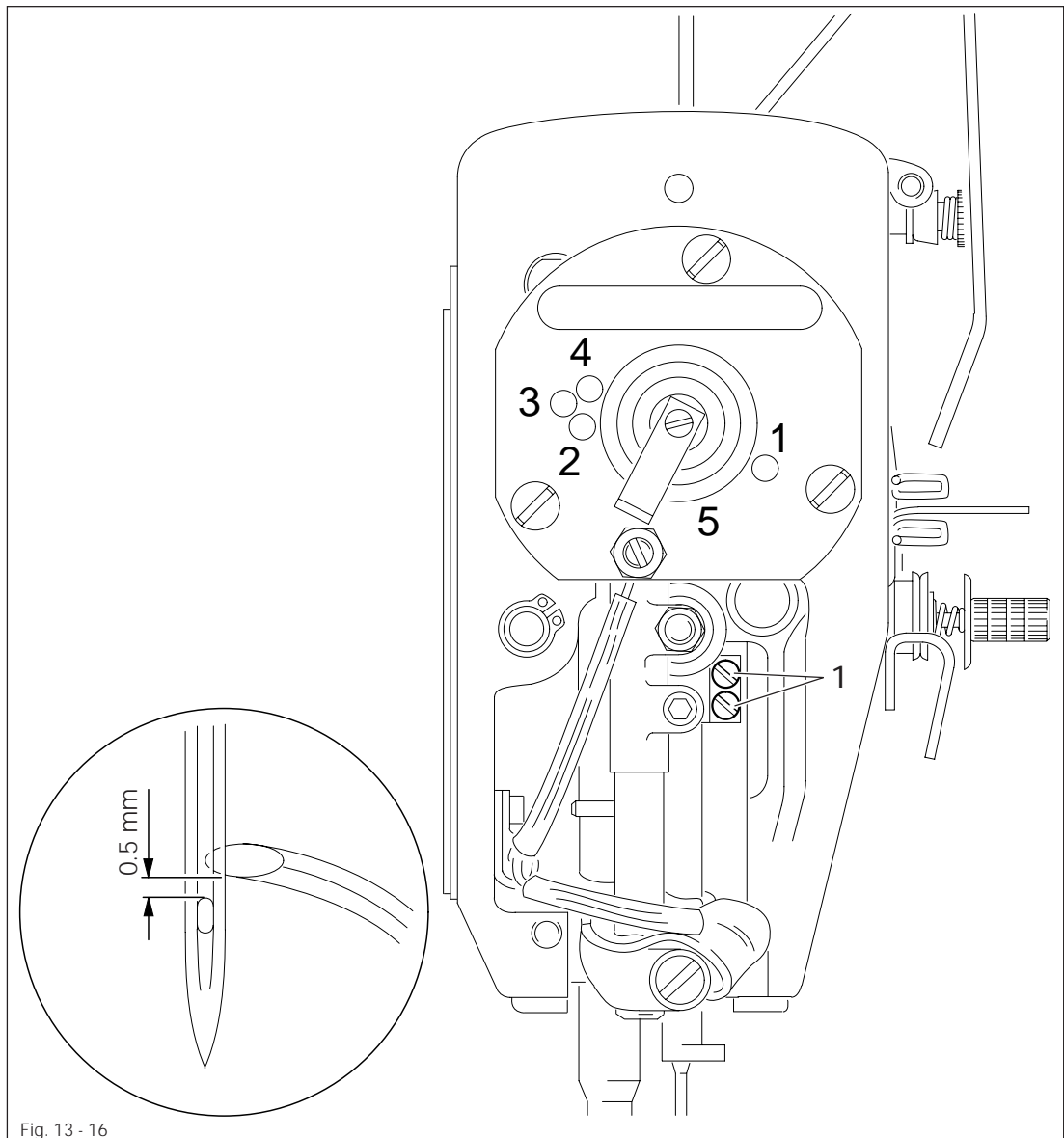

- Move needle bar (screws 1) without twisting it according to the requirement.

## 13.06.15 Bobbin case opener position

## Requirement

1. The top edge of the bobbin opener should extend **0.8 mm** over the bobbin case.
2. When the bobbin opener **2** is in its point of reversal, the front edge of its finger must be approx. **0.6 mm** behind the front edge of the bobbin case trip **6**.
3. At the left point of reversal of the bobbin case opener, the bobbin case position stop must be positioned **at the center** of the slot in the bobbin case base.

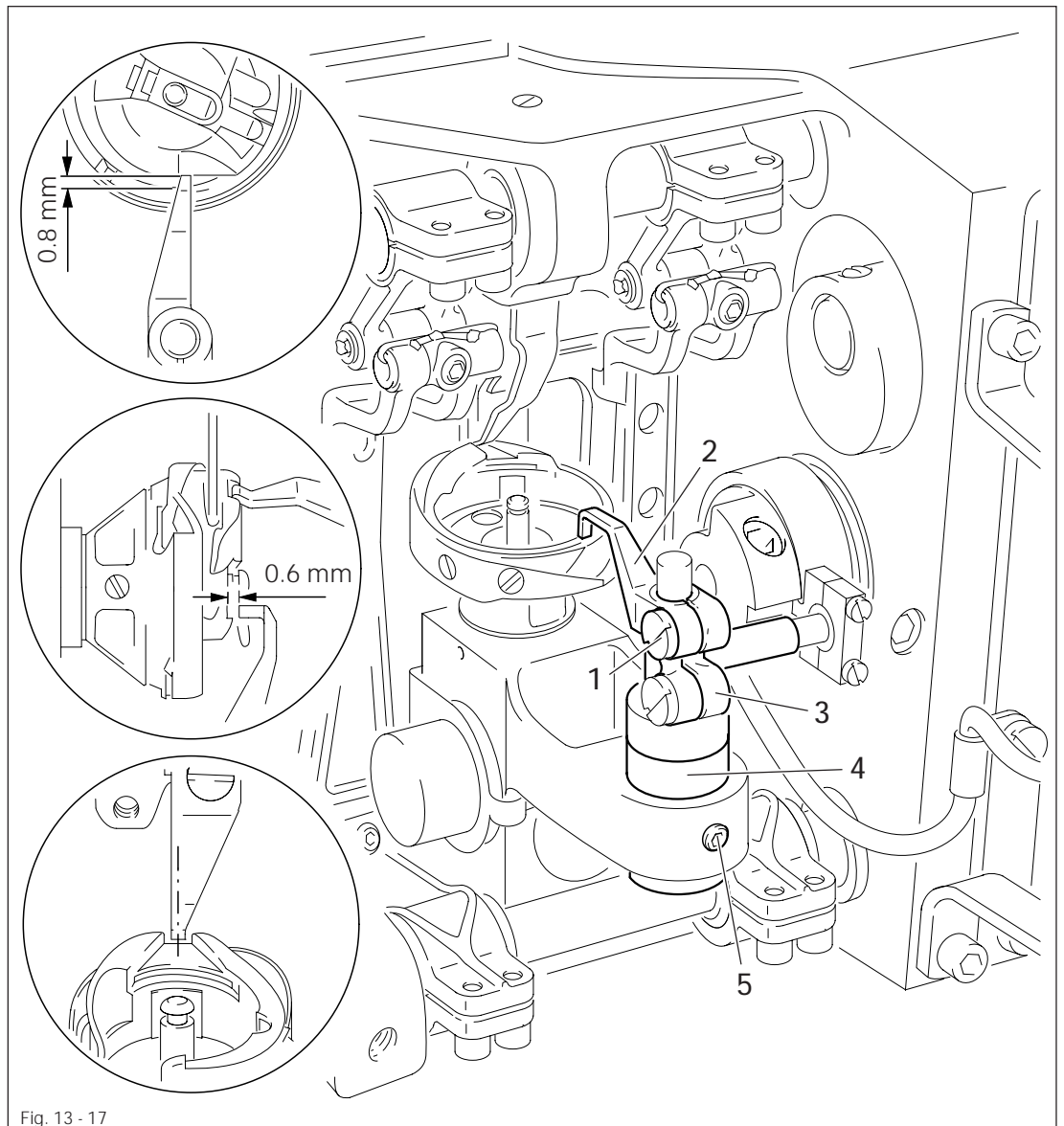
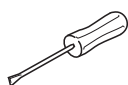

Fig. 13 - 17



- Loosen screw 1.
- Place the bobbin case opener 2 against the right side of the bobbin case base, press against the clamp crank 3 underneath it and tighten screw 1 slightly.
- Adjust bearing bush 4 (screw 5) according to **requirements 1 and 2**.
- Turn bobbin case opener 2 according to **requirement 3** and tighten screw 1, making sure that the bobbin case opener 2 is resting against clamp crank 3.

## 13.06.16 Bobbin case opener movement

### Requirement

With the needle bar 2.4 mm past BDC (hole 1), bobbin case opener 3 must be at its right point of reversal.

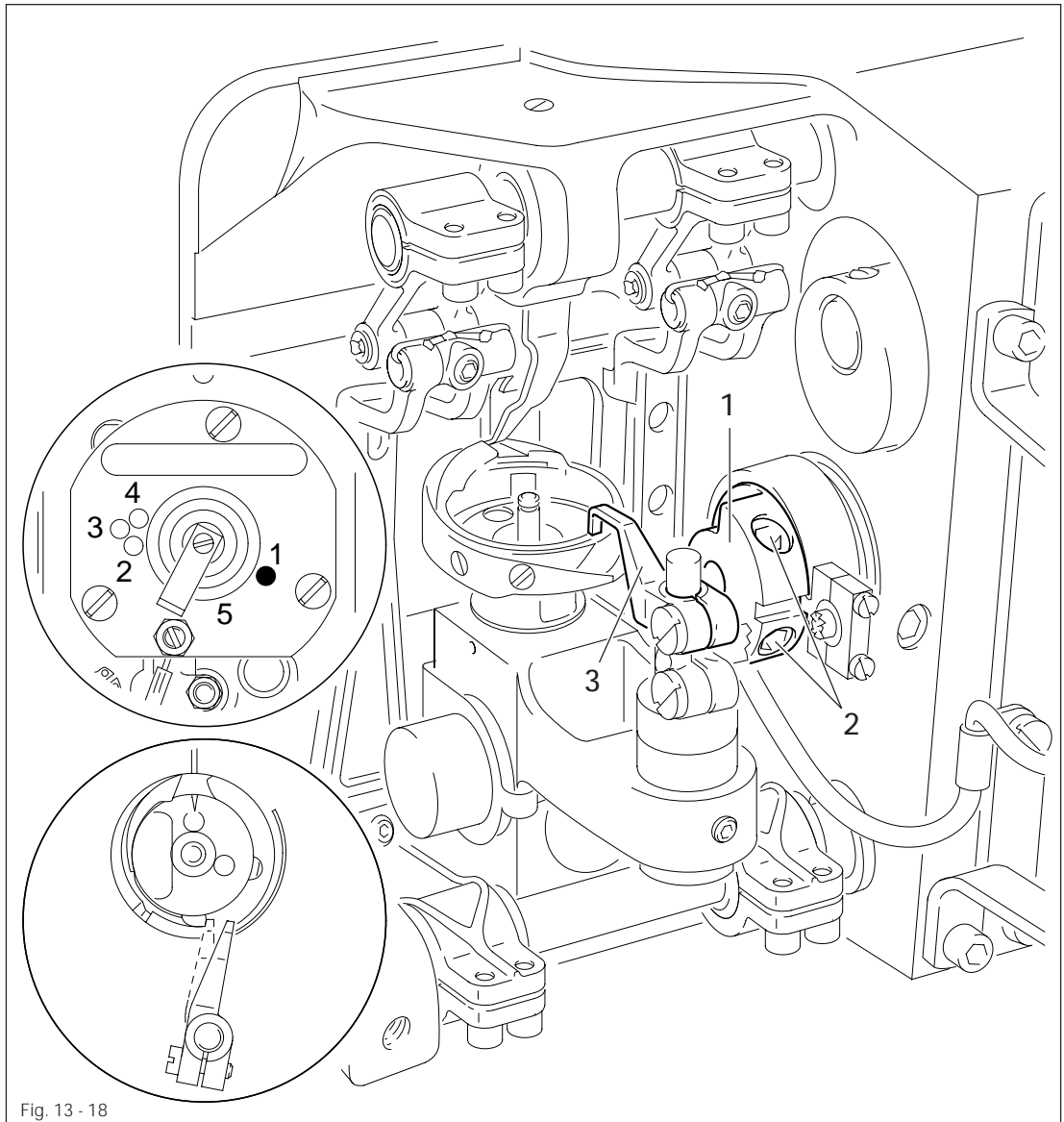
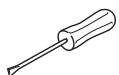

Fig. 13 - 18



- Adjust bobbin case opener eccentric 1 (screws 2) in accordance with the requirement.



## 13.06.17 Counter presser lifting stroke

**Requirement**

At needle bar position BDC, the counter presser is to have just reached the top of its stroke.

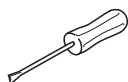
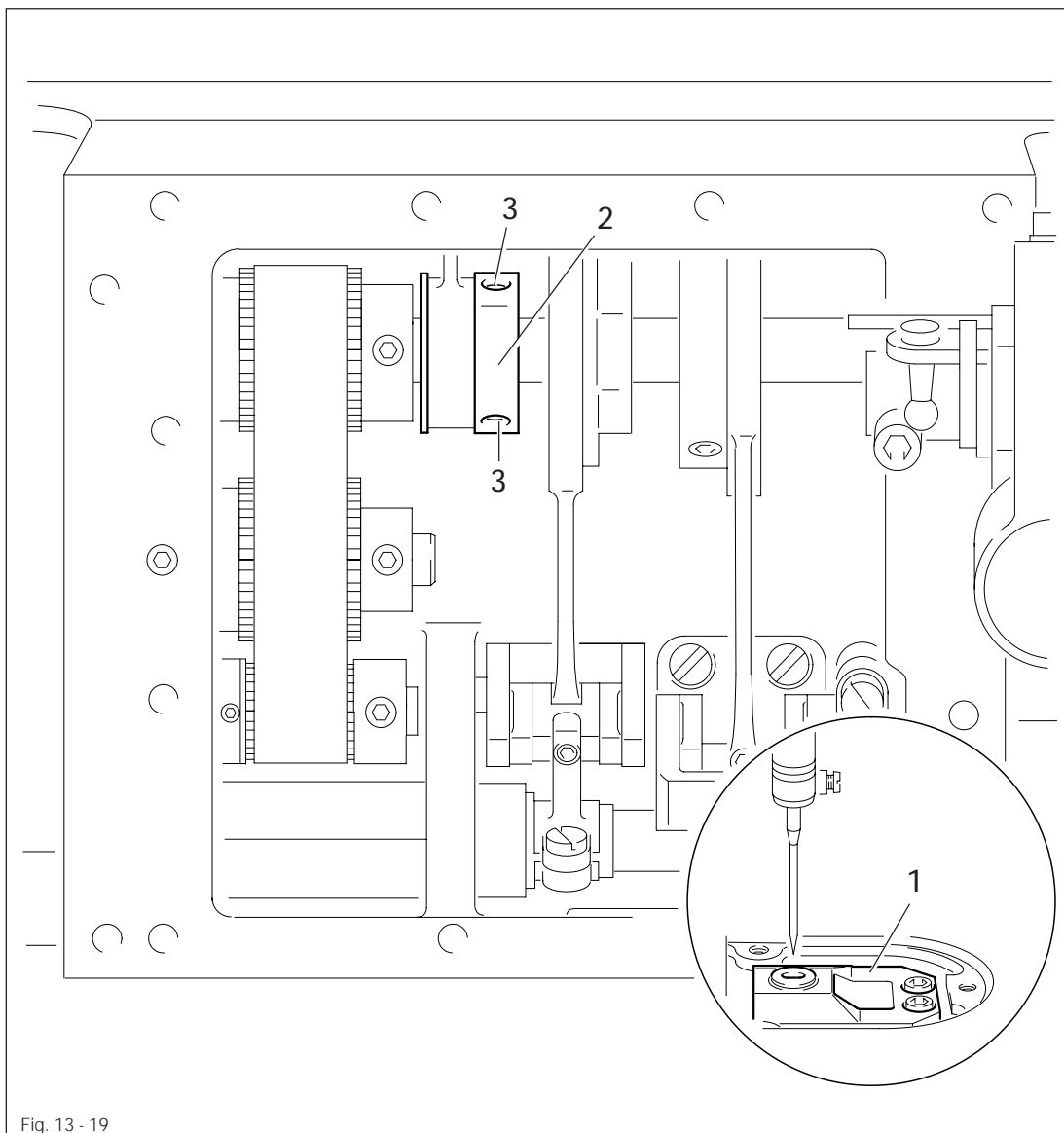

- Unscrew counter presser 1.
- Move needle bar to BDC.
- Turn eccentric 2 (screws 3) according to the **requirement**.

## 13.06.18 Needle guard movement

### Requirement

1. The travel of needle guard finger 1 must be approx. 5 mm.
2. When the distance between the hook point and the needle is 3 mm, the needle guard finger 1 must be at its back point of reversal.

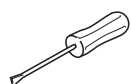
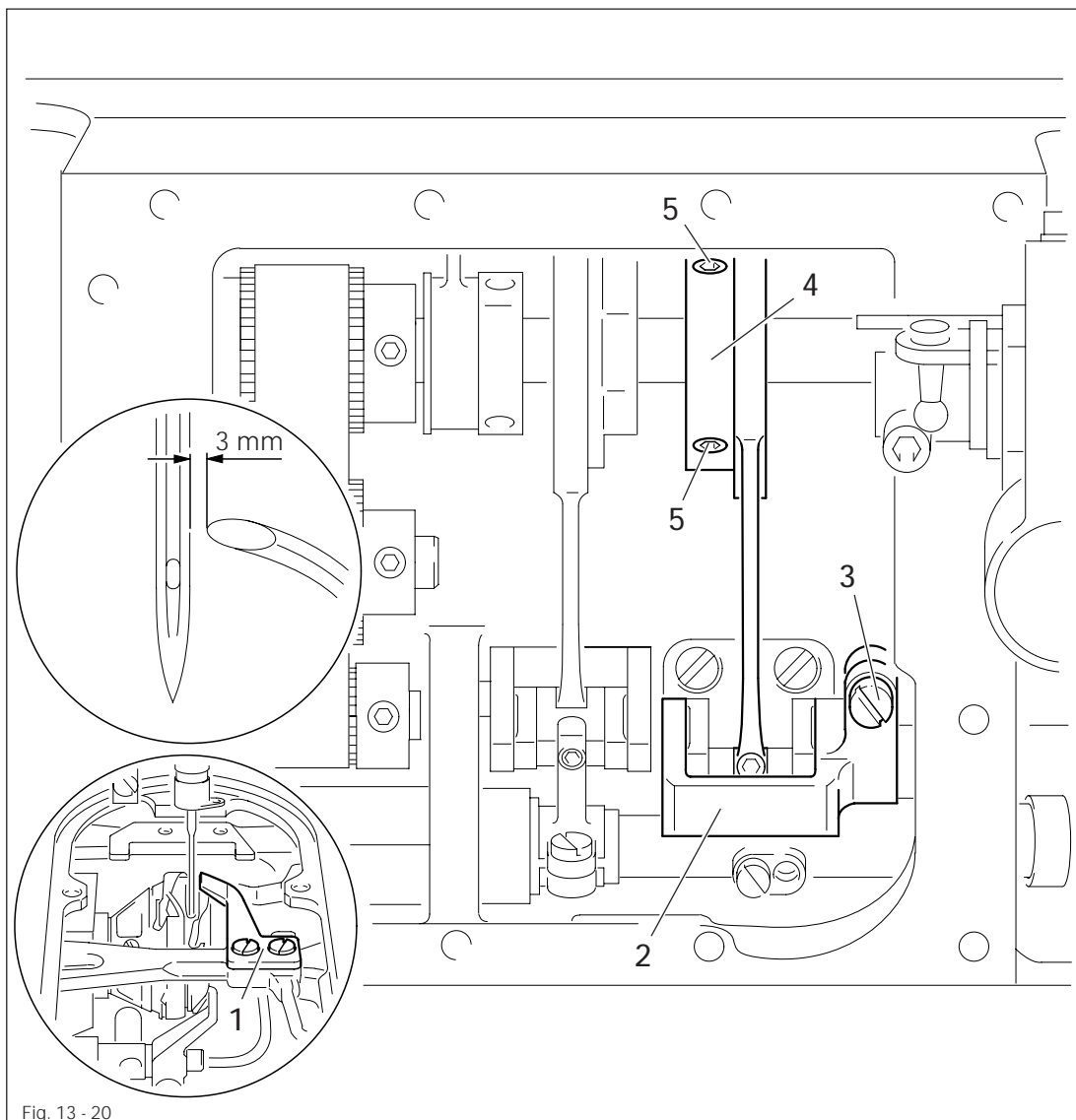

- Unscrew needle guard 1.
- Turn crank 2 (screw 3) according to requirement 1.
- Turn the handwheel in rotating direction until the hook point is 3 mm in front of the needle.
- Hold handwheel firmly and turn eccentric 4 (screws 5) according to requirement 2.

## 13.06.19 Needle guard position

**Requirement**

The needle guard finger 1 must

1. not strike against the thread guard nor the bobbin case base.
2. when at its back point of reversal, be at a distance of 0.5 mm to the needle.

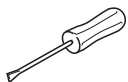
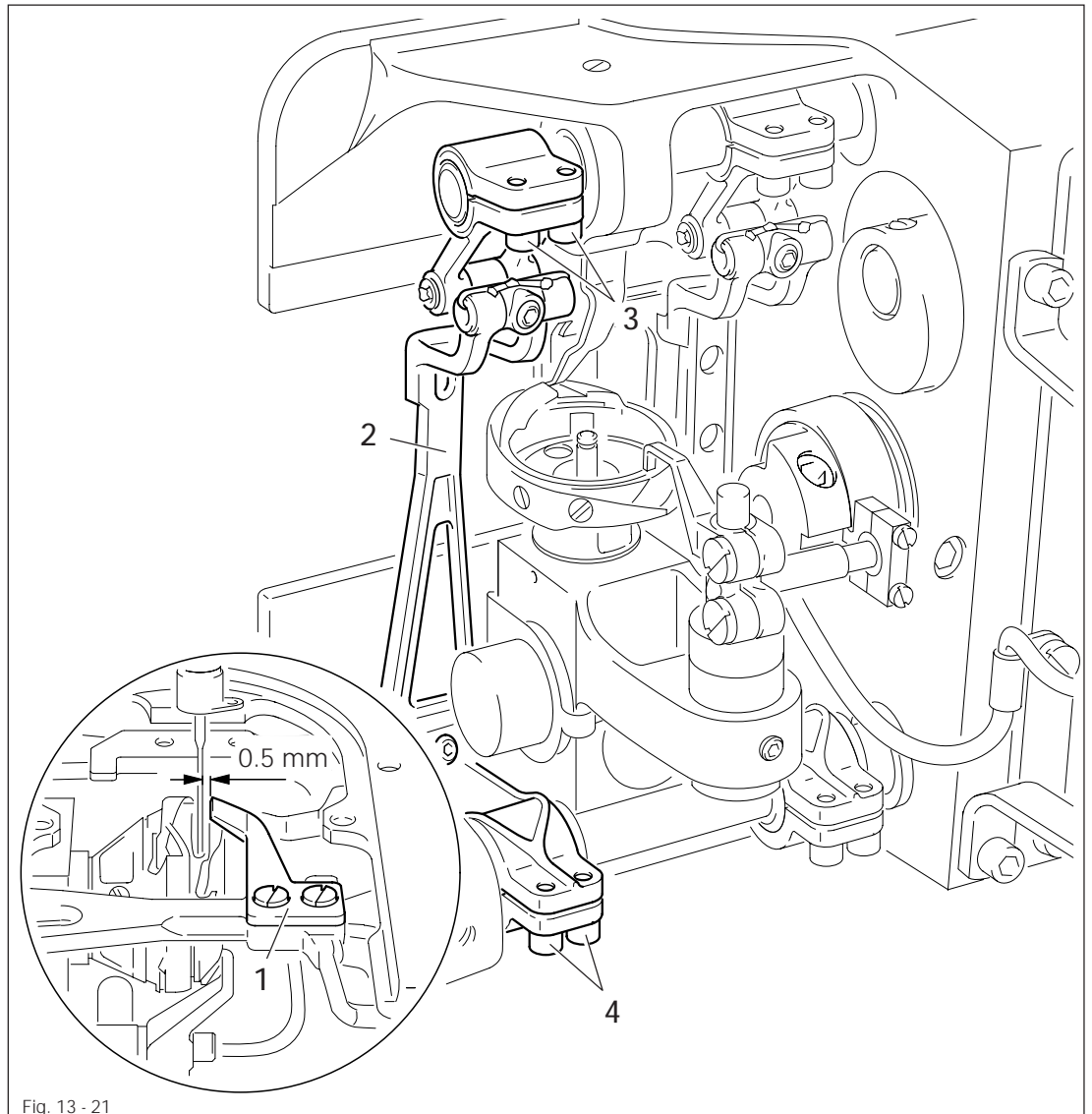

- Adjust the height of the needle guard 1 by adjusting the needle guard bracket 2 (screws 3) according to **requirement 1**.
- By turning the handwheel, position needle guard 1 at its front point of reversal.
- Adjust the needle guard bracket 2 (screws 4) according to **requirement 2**.

## 13.06.20 Counter presser height

### Requirement

At the top point of reversal of the counter presser 1 its surface must be parallel to and 0.3 mm under the cover plate 6.

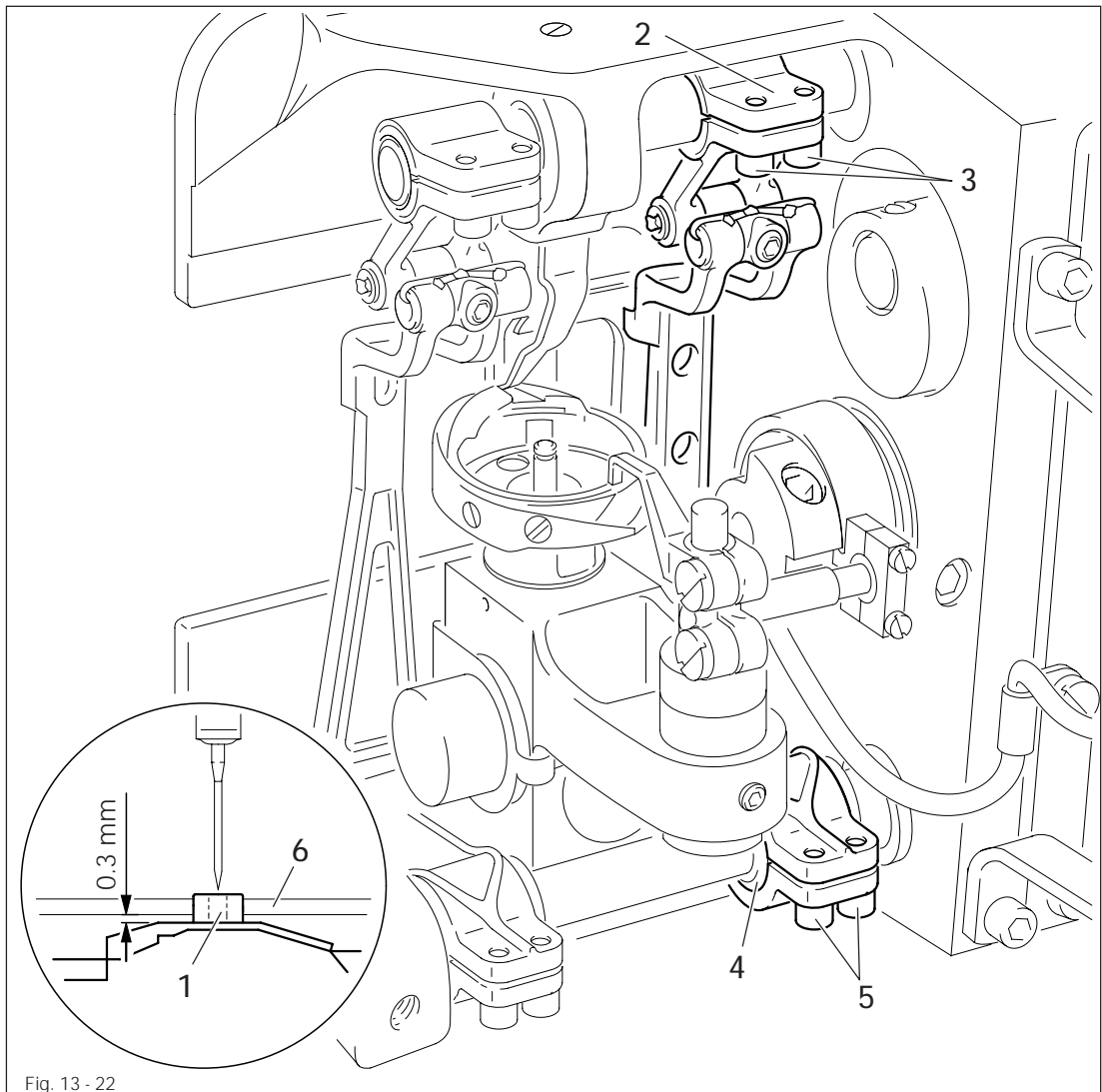
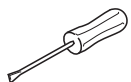

Fig. 13 - 22



- Bring counter presser 1 to its top point of reversal.
- Turn lifting crank 2 (screws 3) and eccentric clamp bush 4 (screws 5) according to the requirement.

## 13.06.21 Counter presser position

## Requirement

1. When the needle penetrates, it must be centered in the needle hole in the counter presser **5**.
2. When the needle bar is at BDC, the counter presser **5** must be at its front point of reversal and with the back edge of the needle hole resting against the needle.

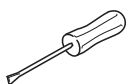
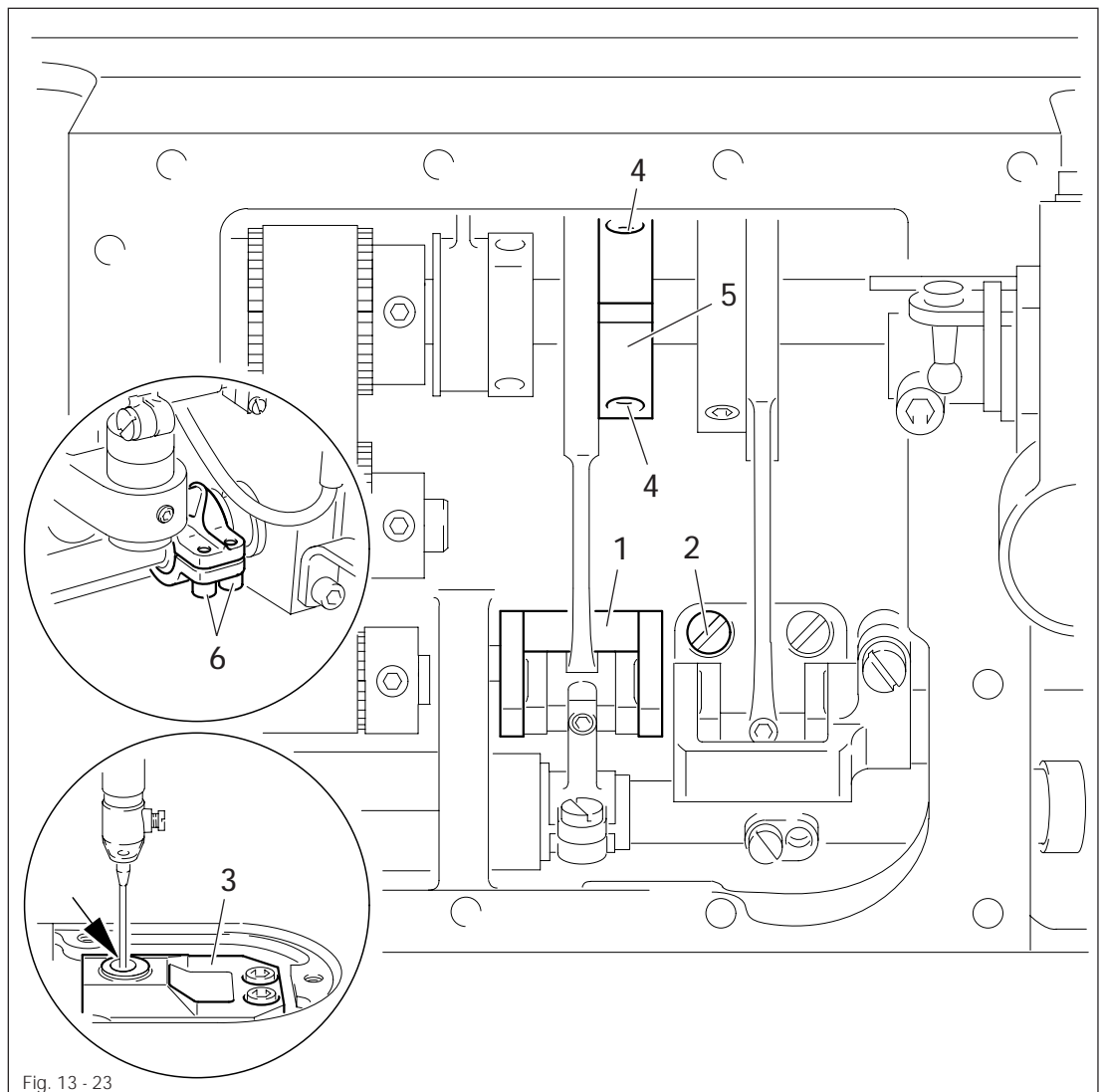

- Turn crank **1** (screw **2**) so that the counter presser **3** travels **0.6 - 1 mm**, and the needle, when it penetrates, is centered in the needle hole in the counter presser **3**.
- Loosen screws **4** just enough so that the eccentric **5** is difficult to turn on the shaft.
- Bring needle bar to BDC.
- Turn eccentric **5** until the counter presser **3** is in its back point of reversal and tighten screws **4**.
- Move counter presser **3** carrier (screws **6**) until the the back edge of the needle hole of the counter presser **3** is resting against the needle (see arrow).



Move counter presser **3** carrier (screws **6**) until the the back edge of the needle hole of the counter presser **3** is resting against the needle (see arrow).

## Requirement

1. When the presser is lowered, the distance to the bedplate must be **6 mm**.
2. When the presser is raised, the distance to the bedplate must be **17 mm**.

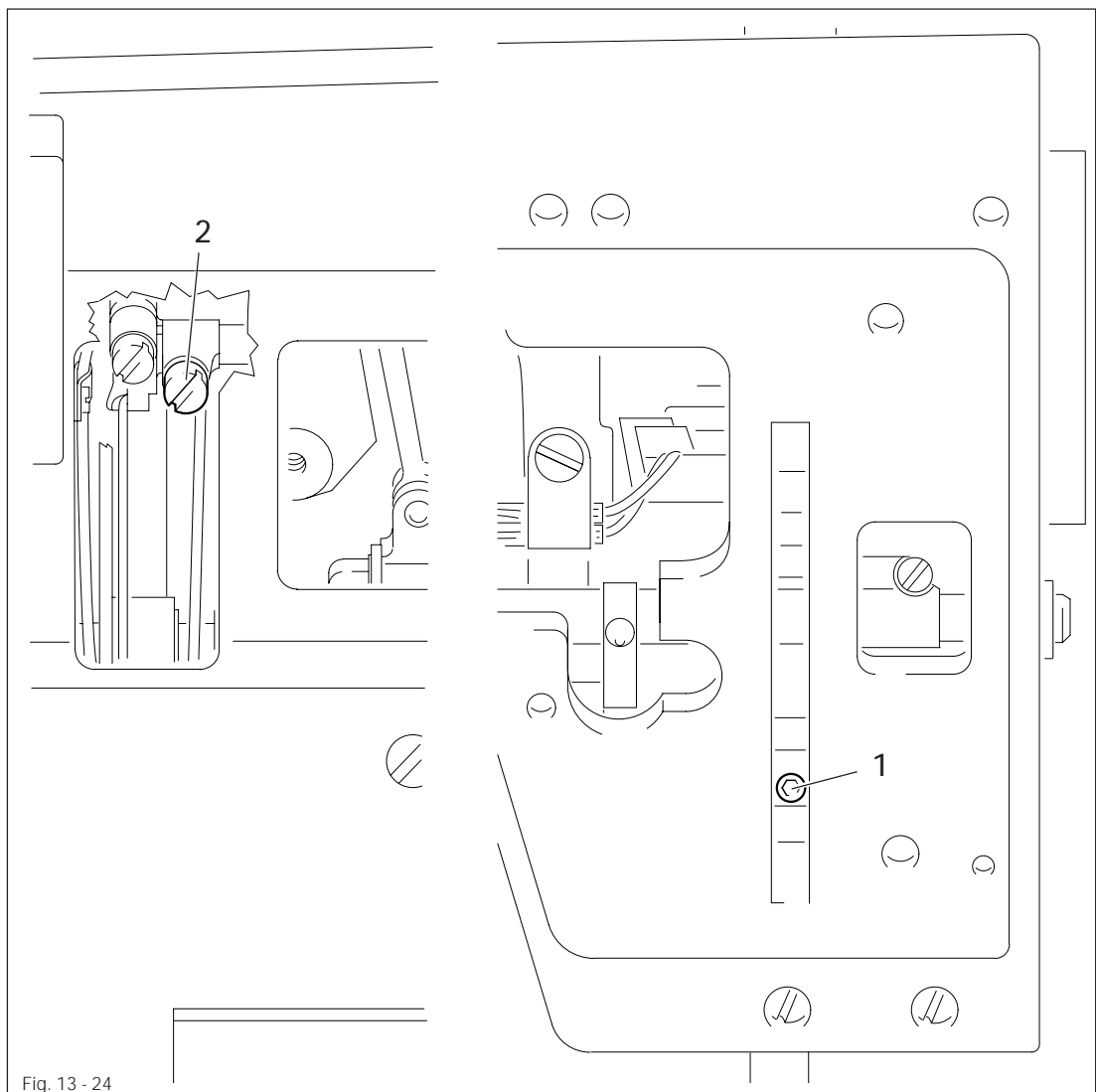
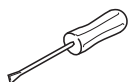

Fig. 13 - 24



- Lower presser.
- Move presser (screw 1) according to **requirement 1**.
- Allow the presser to be raised.
- Loosen screw 2.
- Place spacer with a height of **17 mm** underneath the presser.
- Adjust the distance between the presser and the bedplate according to **requirement 2**.
- Turn screw 2 slightly.

## 13.06.23 Needle thread tension release

**Requirement**

1. When the presser is raised, the distance between the tension disks must be at least **0.5 mm**.
2. When the thread trimmer is in its resting position, there must be a distance of **0.5 mm** between the trips **8** and the release olive **5**.
3. When the trips **8** are at the highest point of the release olive **5**, the distance between the tension disks must be at least **0.5 mm**.

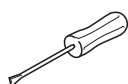
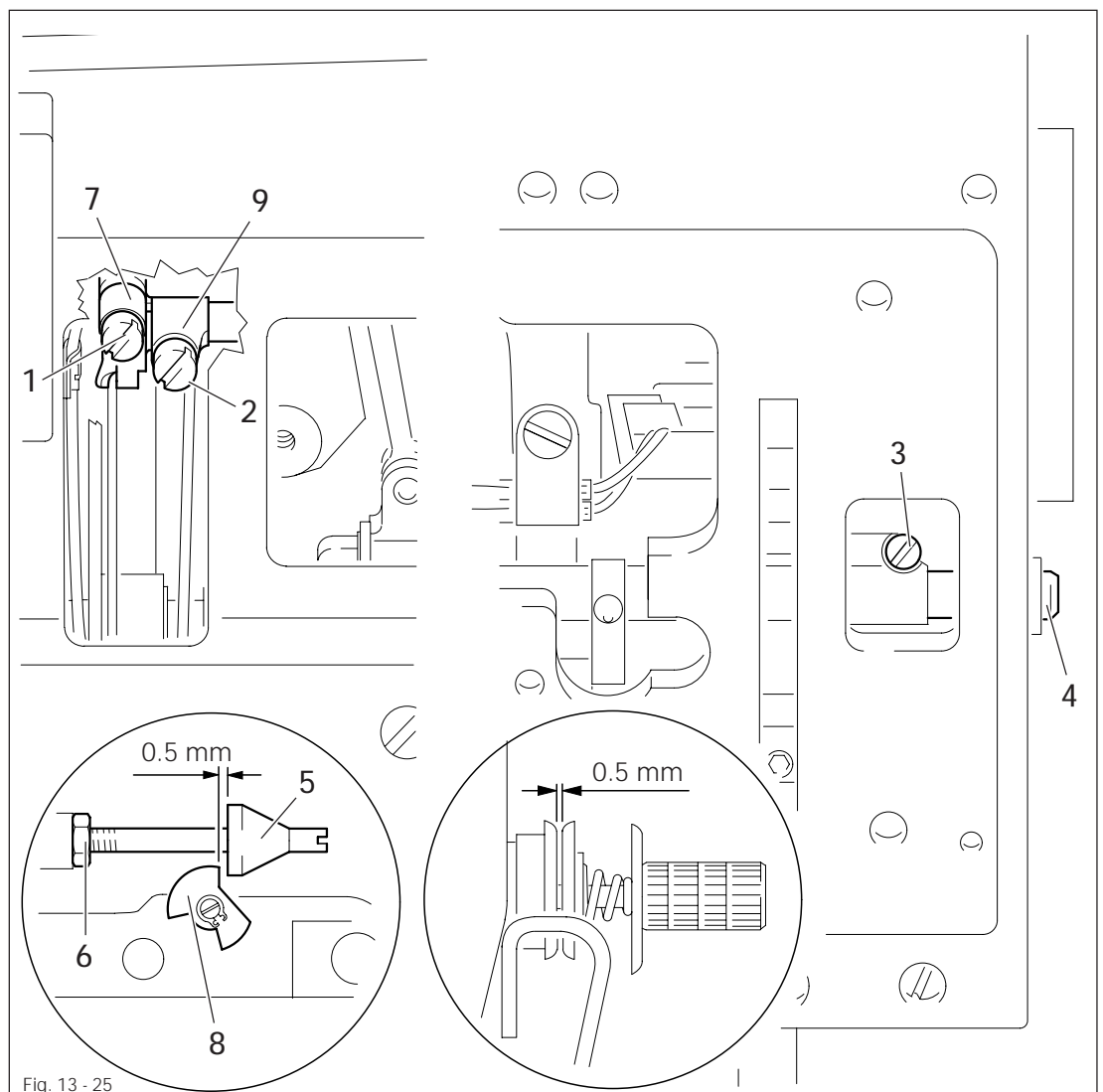

- Loosen screws **1**, **2** and **3**.
- Lift the presser and place spacer with a height of **17 mm** underneath it.
- Adjust the distance between the tension disks according to **requirement 1** by turning the hollow shaft **4**. To turn the hollow shaft **4**, jam the front end of a screwdriver in the hollow shaft **4**.
- Tighten screw **3**.
- Bring thread trimmer to its resting position.
- Move release olive **5** (nut **6**) according to **requirement 2**.
- Remove spacer.

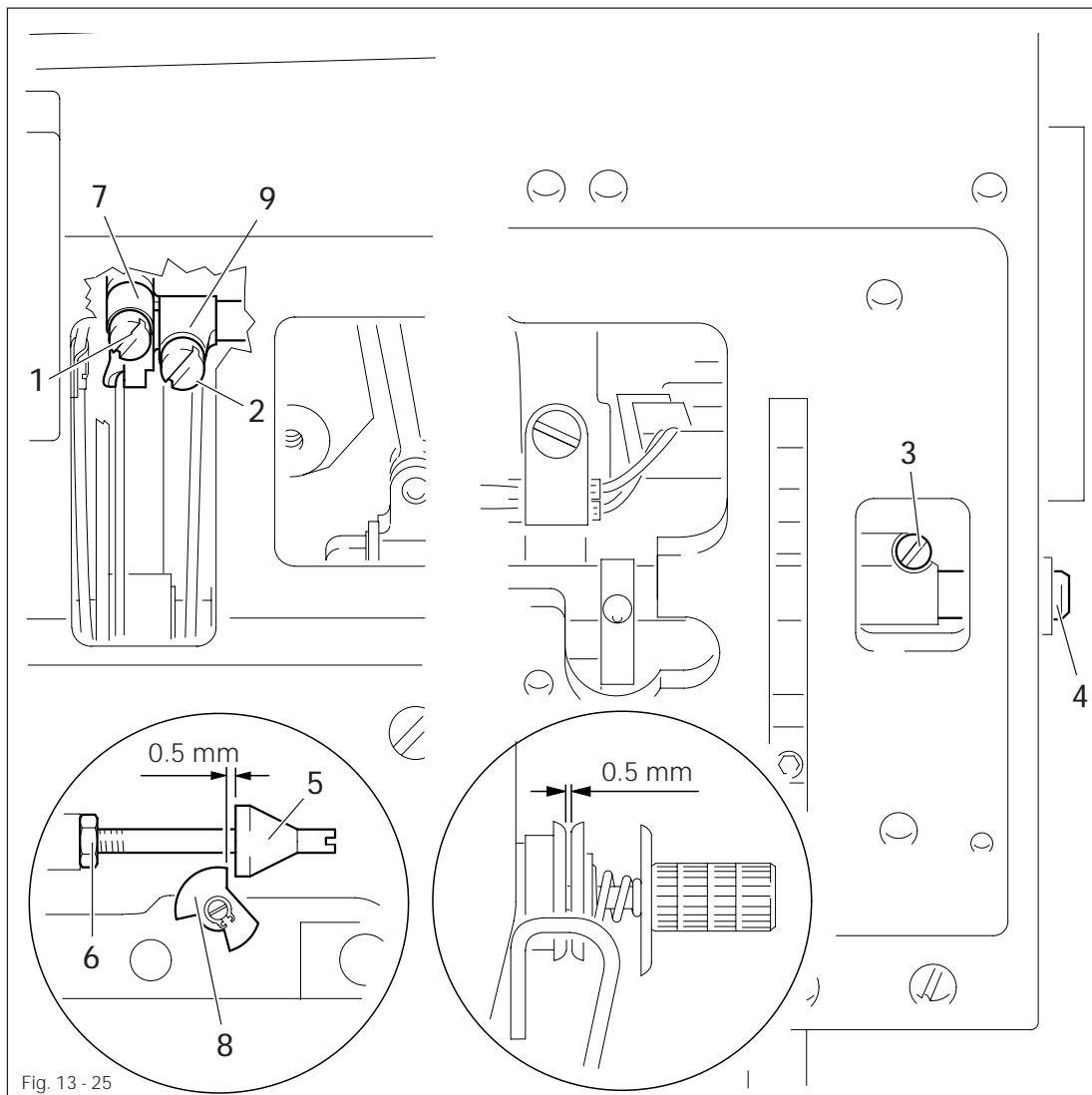
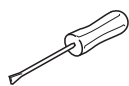

Fig. 13 - 25



- Press clamp 9 up to the top.
- Tighten screw 2, ensuring that the hollow shaft 4 does not have any lateral play.
- Turn on thread trimmer manually.
- Turn the handwheel until the trips 8 are positioned at the highest point of the release olive 5.
- By turning the tension release shaft (accessible via screwdriver through hollow shaft 4), adjust the distance between the tension disks according to requirement 3.
- Press crank 7 up to the top and tighten screw 1.
- Grease release olive 5 lightly.



The clearance between the tension discs can be fine-tuned at eccentric pin 10 after nut 11 has been loosened.



## 13.06.24 Thread check spring

**Requirement**

The stroke of thread check spring 3 must be approx. 5 mm.

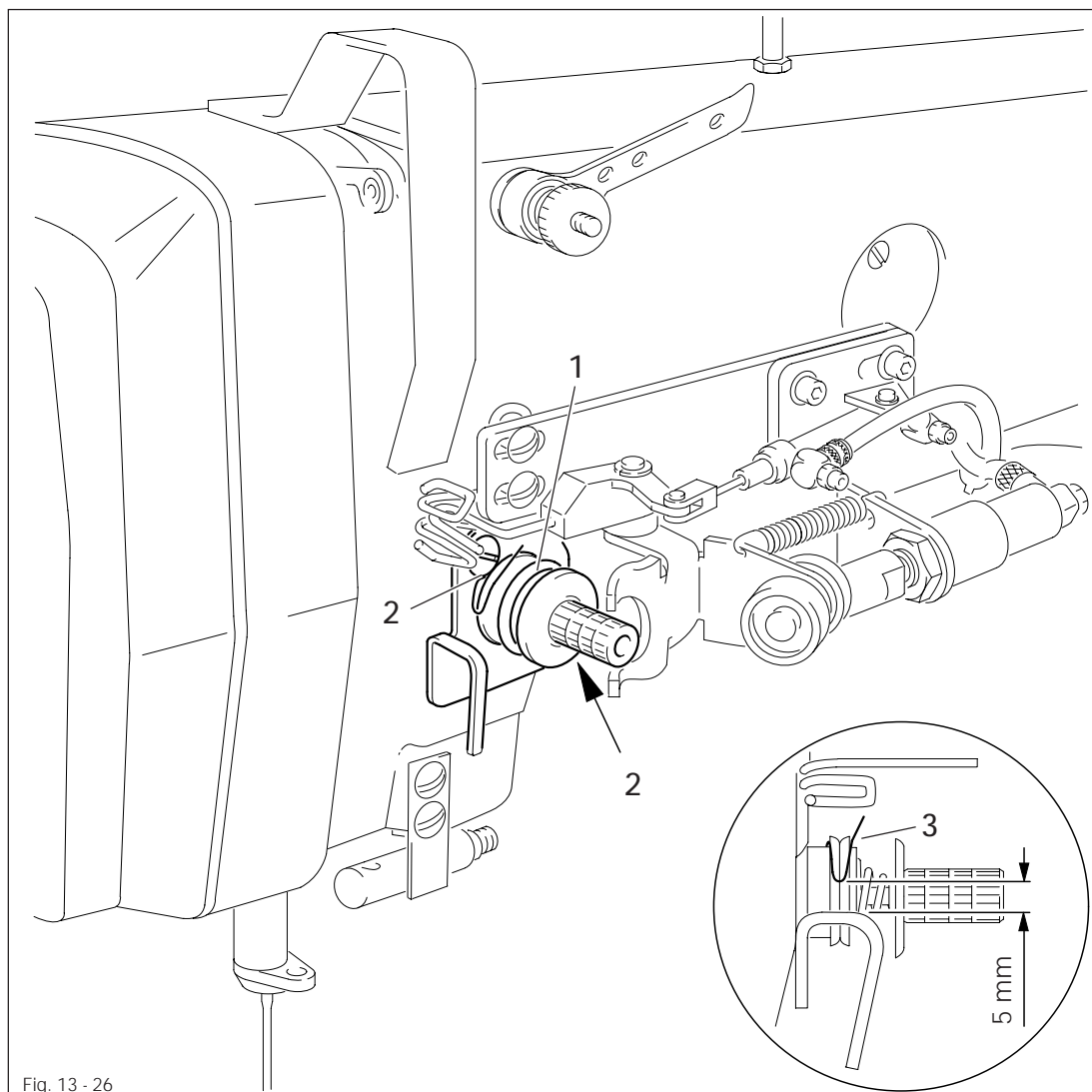
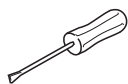

Fig. 13 - 26



- Tilt sewing machine head upright and insert.
- Turn tension block 1 (screws 2) according to the requirement.

## 13.06.25 Thread puller

### Requirement

The thread puller **3** must pull enough thread after the sewing operation is finished so that a reliable seam start is ensured.

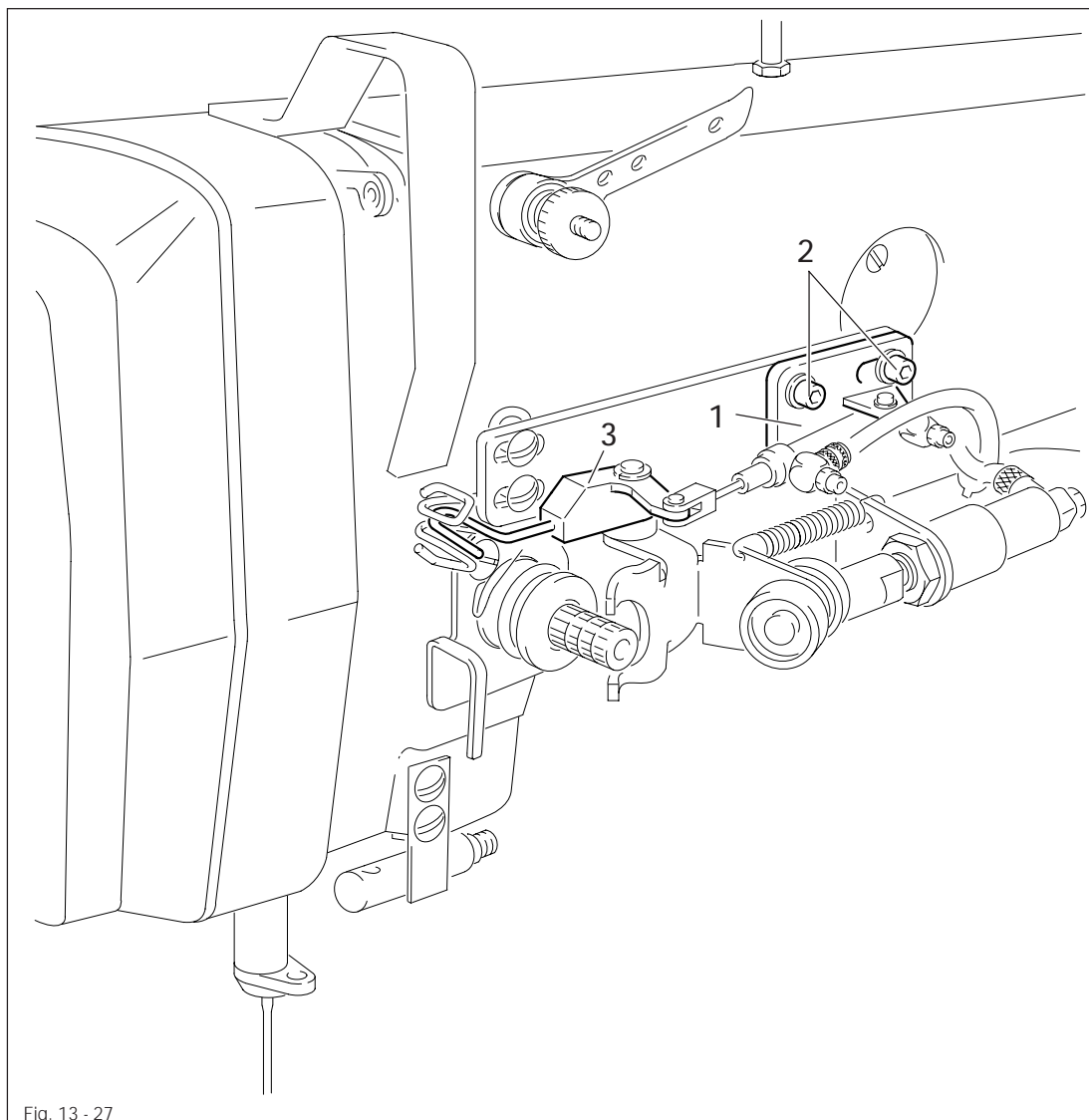
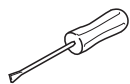

Fig. 13 - 27



- Move cylinder carrier **1** (screws **2**) according to the requirement.



The timing of the thread puller must be set so that the cylinder of the thread puller can carry out its full stroke (see chapter 11.01.03 Summary of the functions in the 2nd menu level and chapter 11.04.02 Functions in the 2nd menu level).

## 13.06.26 Bobbin winder

### Requirement

The bobbin winder must disengage when the thread level is approx. 1 mm from the edge of the bobbin.

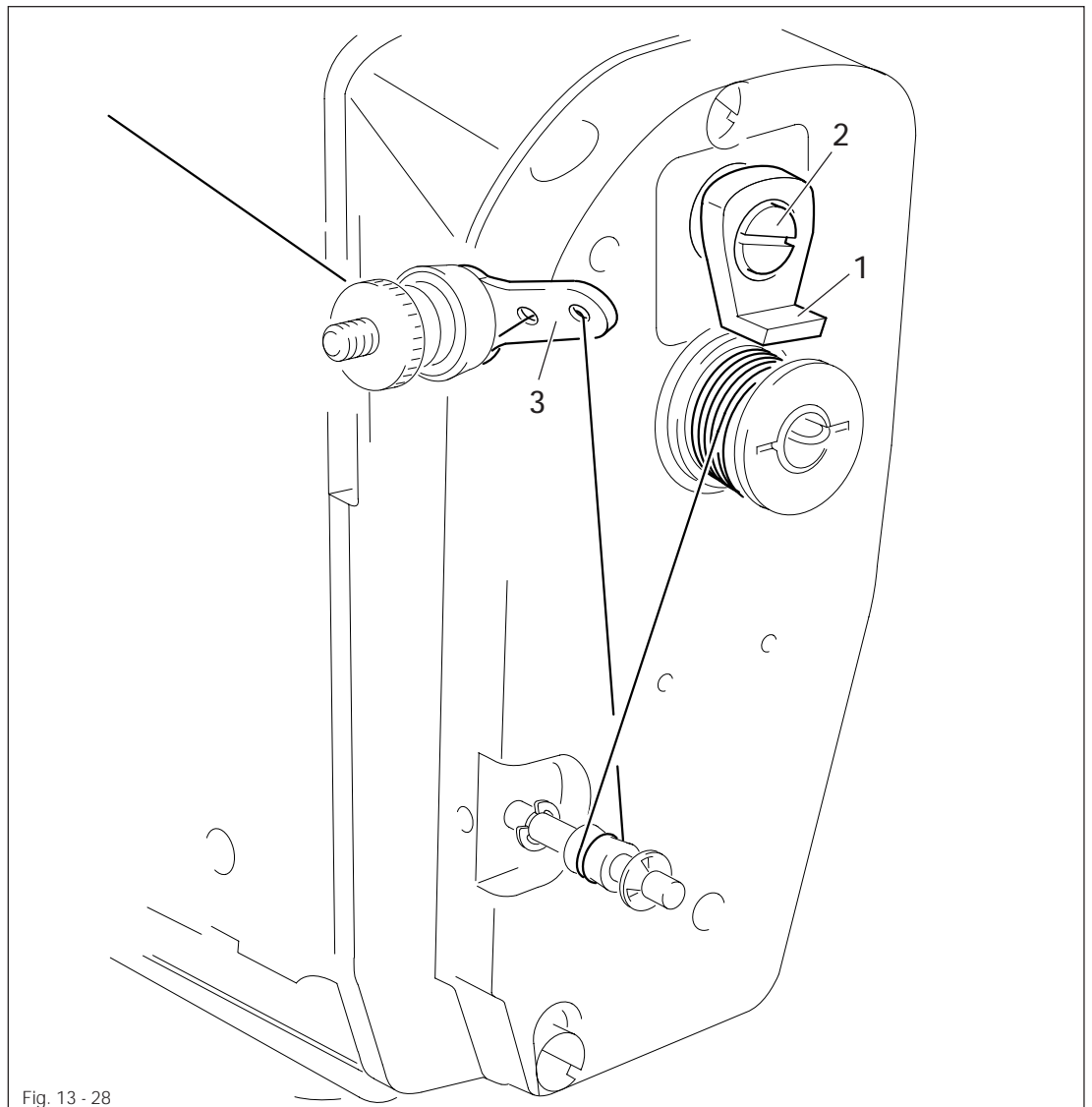
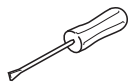

Fig. 13 - 28



- Move trip 1 (screw 2) according to the **requirement**.
- If the bobbin is wound unevenly, adjust the thread guide 3 accordingly.

# Adjustment

## 13.06.27 Synchronizer

### Requirement

After the sewing action has been completed, the machine is to position at TDC of the needle bar (hole 2).

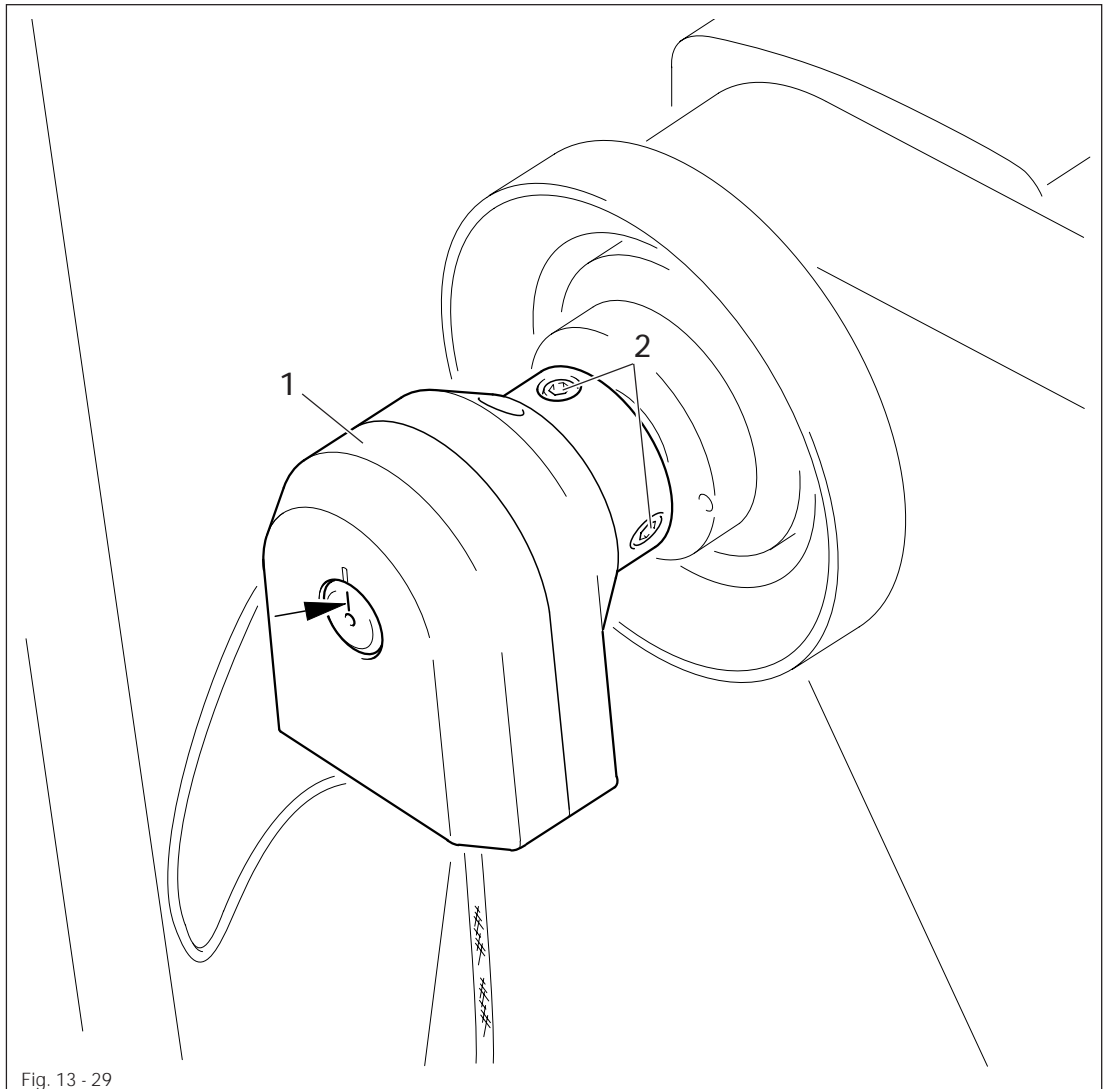
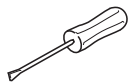

Fig. 13 - 29



- Allow sewing machine to carry out positioning (switch on/off).
- Mark this position on the shaft (see arrow).
- Bring the needle bar to TDC (hole 2).
- Turn synchronizer 1 (screws 2) until the mark on the shaft and the synchronizer 1 are aligned again.

## 13.07 Adjusting the thread trimmer

## 13.07.01 Mounting/dismounting the control unit

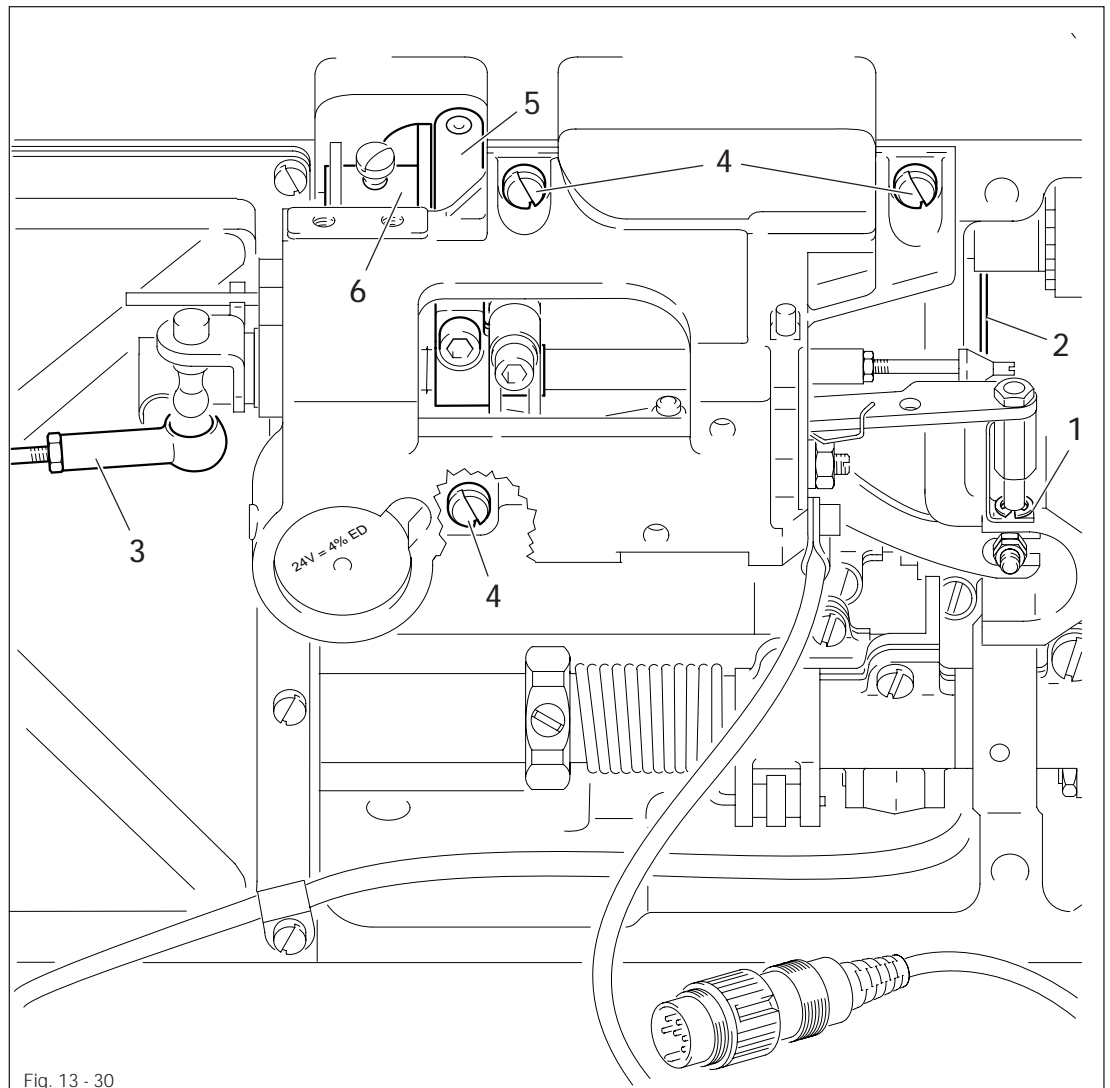
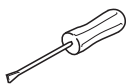

Fig. 13 - 30



- Remove sewing machine head and tilt back.
- To **dismount**, remove circlip 1 and detach pull rod 2.
- Detach spherical heads of the connecting rod 3 from the ball pins on the trimmer and control units and remove connecting rod 3.
- Unscrew control unit (screws 4).
- To **mount**, bring needle bar to 2.4 past BDC (hole 1)
- Mount control unit and connect pull rod 2.
- Screw on control unit (screws 4), tightening the screws lightly, and fit circlip 1.
- Bring needle bar to BDC and actuate the engaging lever by hand.
- Align the control unit so that the roller lever 5 is centered at the cam recess of the control cam 6.
- Tighten screws 4 and fit connecting rod 3.

## 13.07.02 Preadjusting the control cam

### Requirement

When the needle bar is at TDC (hole 2)

1. the beginning of the highest boss of the trip 5 must be under the tip of the latch 7, and
2. the right side of the trip must be flush with the right side of the latch 7.

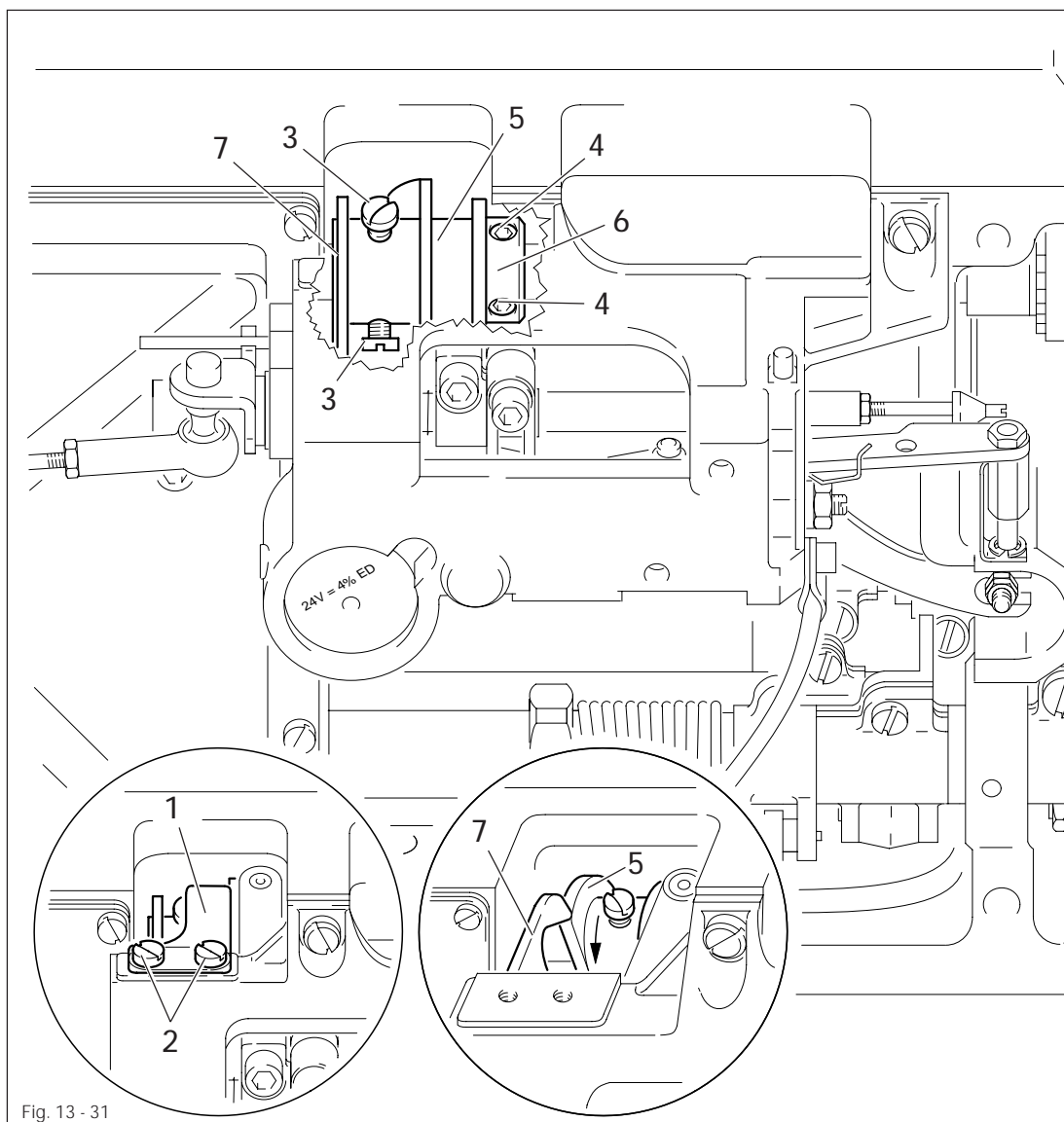
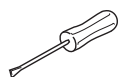

Fig. 13 - 31



- Remove catch spring 1 (screws 2) together with the cover disk.
- Loosen screws 3 and 4.
- Turn control cam 5 according to requirement 1 and/or slide according to requirement 2 and tighten screws 3.
- Slide retaining collar 6 to control cam 5 and tighten screws 4.



Catch spring 1 remains dismantled for further adjustments.

## 13.07.03 Roller lever

**Requirement**

With the needle bar at 2.4 past BDC (hole 1),

1. when the roller lever 4 is tapped the roller must engage easily in the control cam 7, and
2. the roller of the roller lever 4 must be centered at the cam recess of the control cam 7.

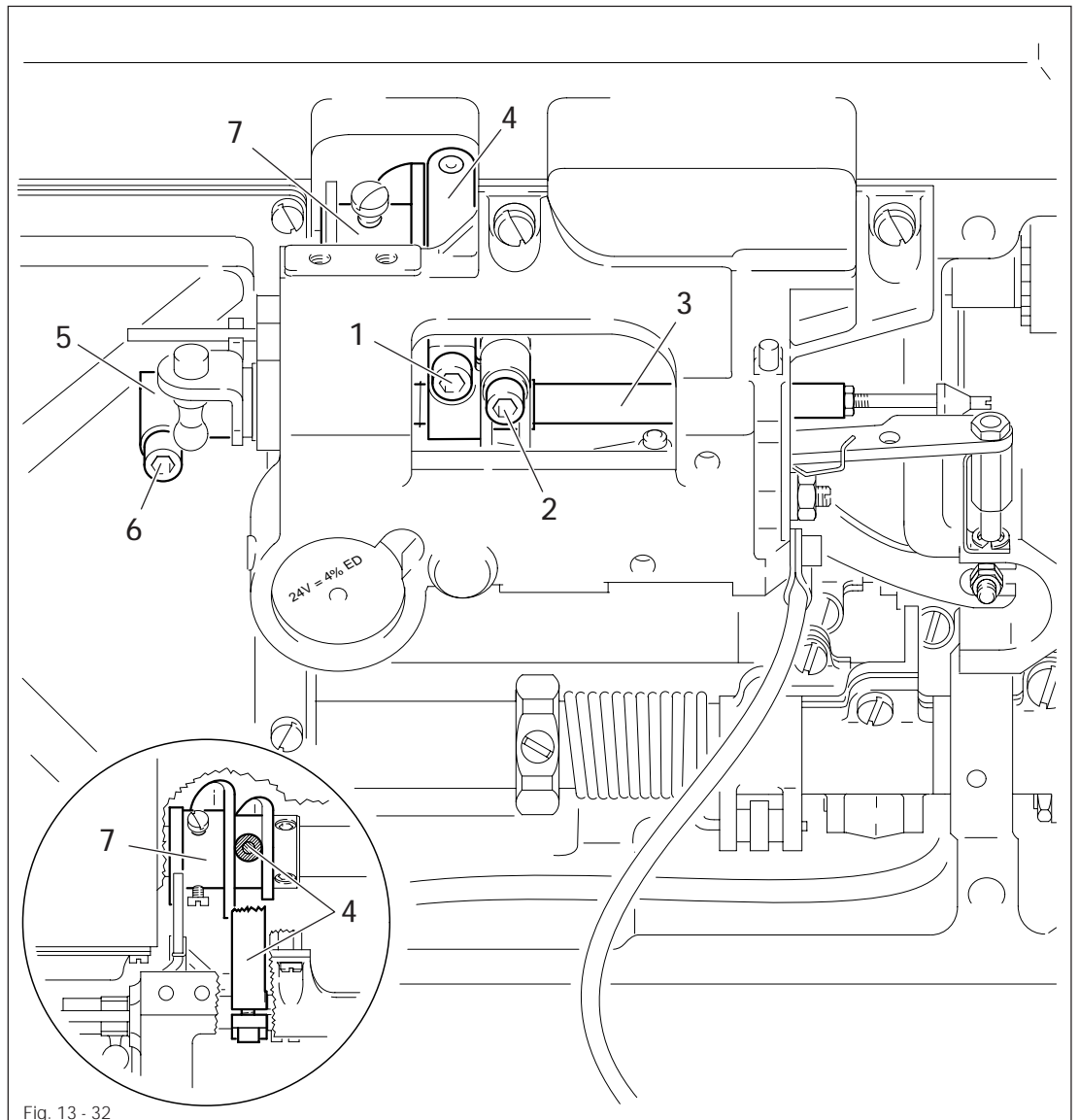
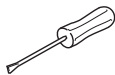

Fig. 13 - 32



- Loosen screws 1 and 2.
- Press the rock shaft 3 to the right.
- Adjust the roller lever 4 according to requirements 1 and 2.
- Tighten screw 1.
- Position the surface of the retaining collar 5 (screw 6) parallel to the bedplate.



Screw 2 remains loosened for further adjustments.

## Requirement

When the thread trimmer is in its resting position, there must be a distance of **0.3 mm** between the latch **2** and the largest eccentricity of the trip of the control cam **1**.

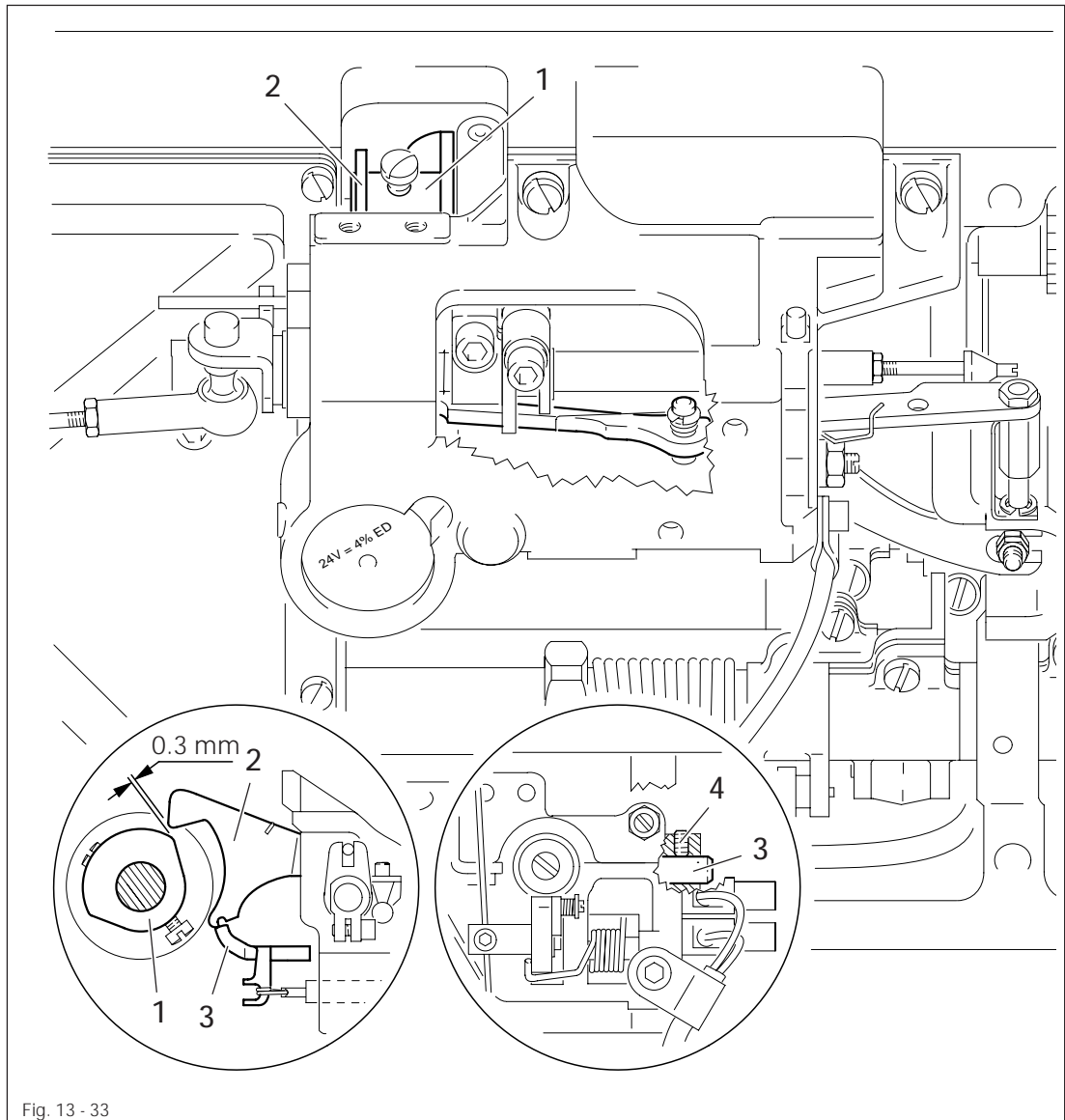
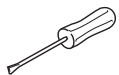

Fig. 13 - 33



- By turning the handwheel, position the trip of the control cam **1** with its largest eccentricity under the latch **2**.
- Adjust the engaging lever **3** (screw **4**) according to the **requirement**.



## 13.07.05 Engaging solenoid

**Requirement**

With the needle bar at 2.4 past BDC (hole 1), when the engaging solenoid is in operation, there must be a distance of 0.2 to 0.3 mm between the engaging lever 1 and the latch 2.

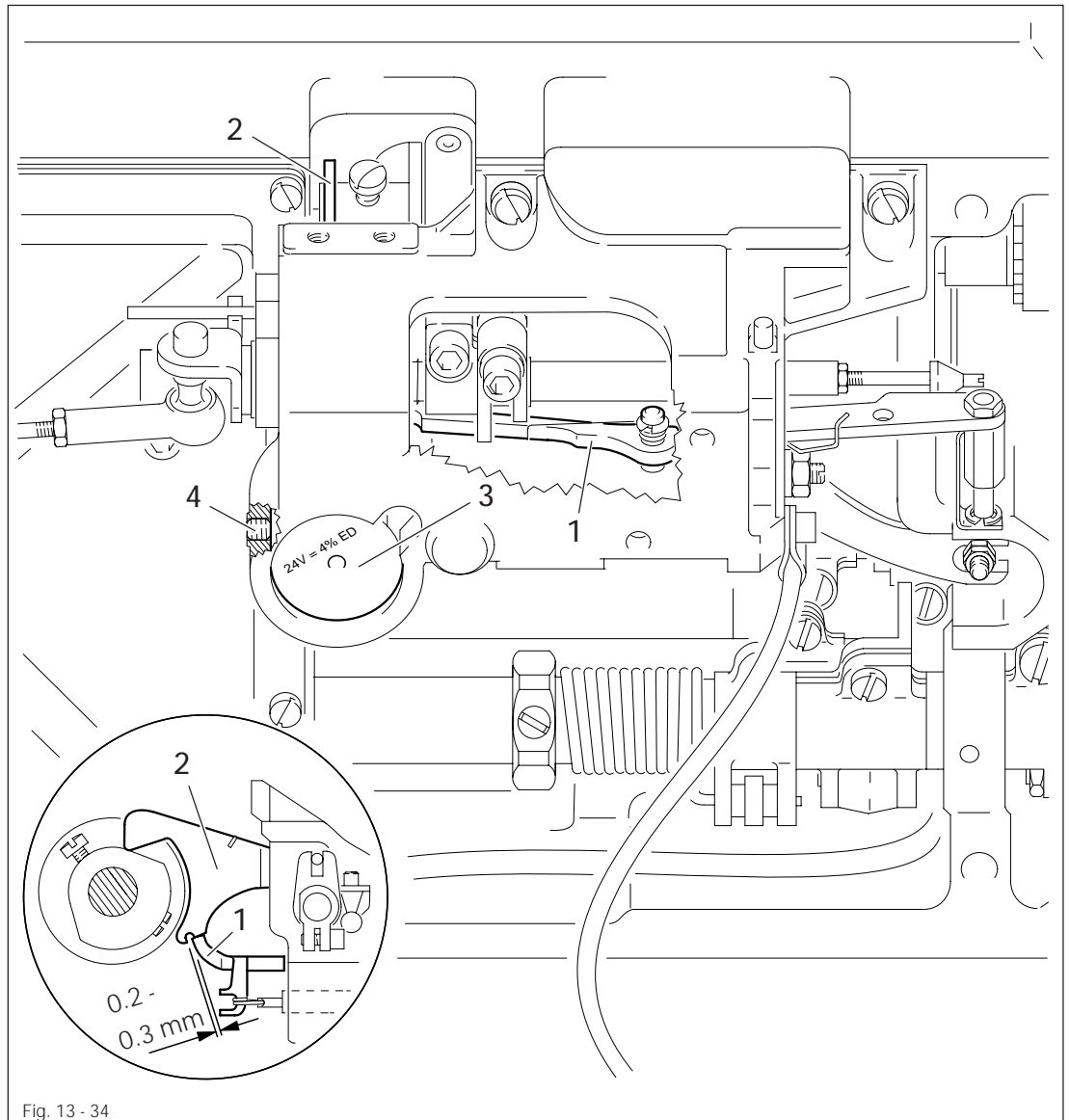
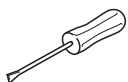

Fig. 13 - 34



- Bring needle bar to 2.4 past BDC (hole 1).
- Operate engaging lever 1 by hand until the latch 2 engages.
- Press the magnetoinductor as far as it will go into the solenoid housing 3. Move solenoid housing 3 (screw 4) together with the magnetoinductor according to the **requirement**.

## 13.07.06 Actuating lever

### Requirement

With the needle bar at 2.4 past BDC (hole 1), when the actuating lever 1 is actuated, there must be a distance of 0.2 mm between the roller of roller lever 2 and the base of the control cam 3.

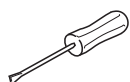
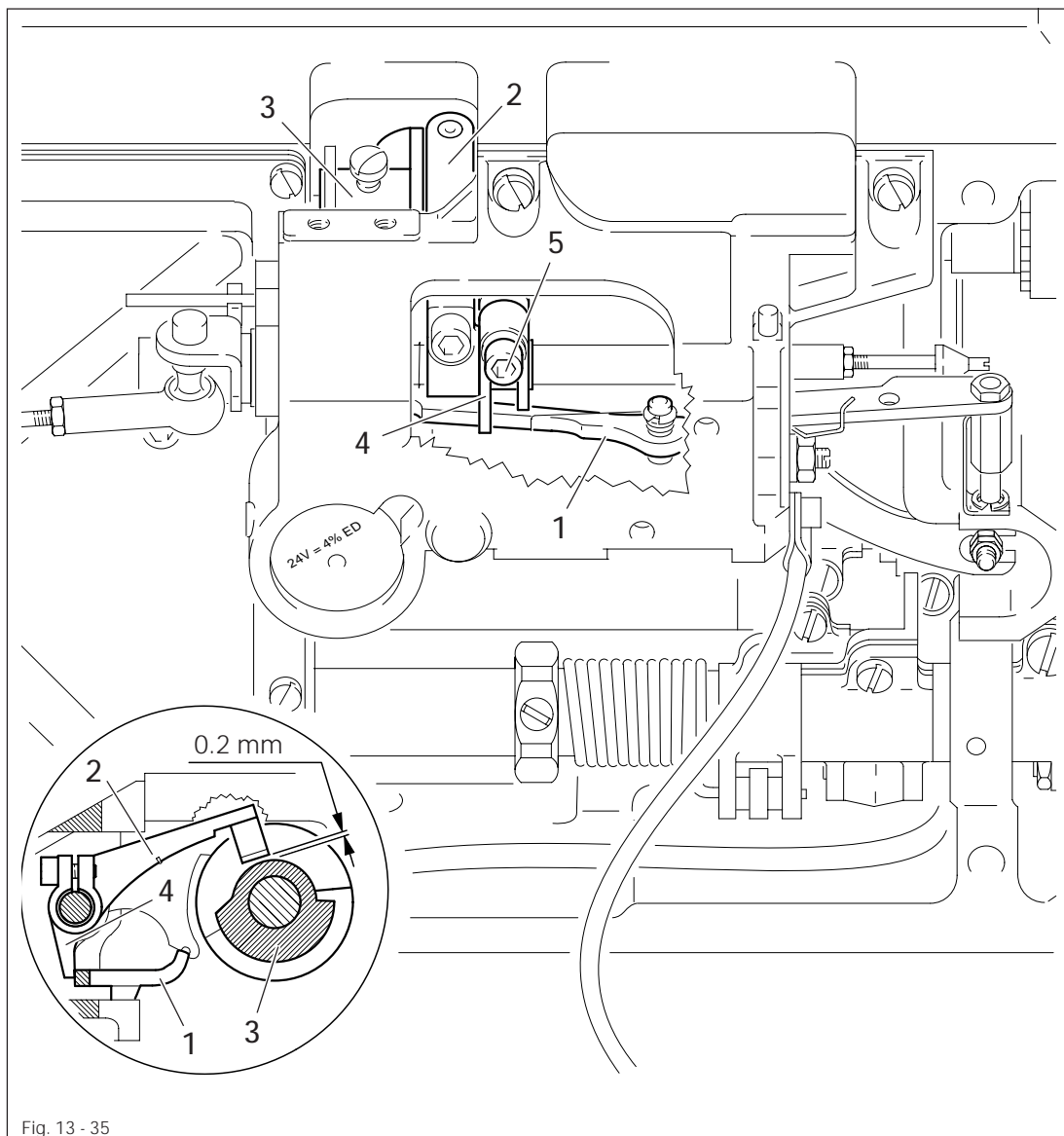

- Bring needle bar to 2.4 past BDC (hole 1).
- Operate actuating lever 1 by hand.
- Press roller lever 2 until it is at the base of the control cam 3.
- Position lever 4 at actuating lever 1 so that a distance of 0.2 mm is achieved between the roller lever 2 and the base of the control cam 3. In the process, lever 4 is to rest laterally against roller lever 2.
- Tighten screw 5.

## 13.07.07 Engaging lever

**Requirement**

With the needle bar at TDC (hole 2) and the thread trimmer in resting position, there must be a distance of **0.3 to 0.5 mm** between the roller of the roller lever 3 and the outside diameter of the control cam 4.

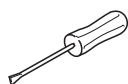
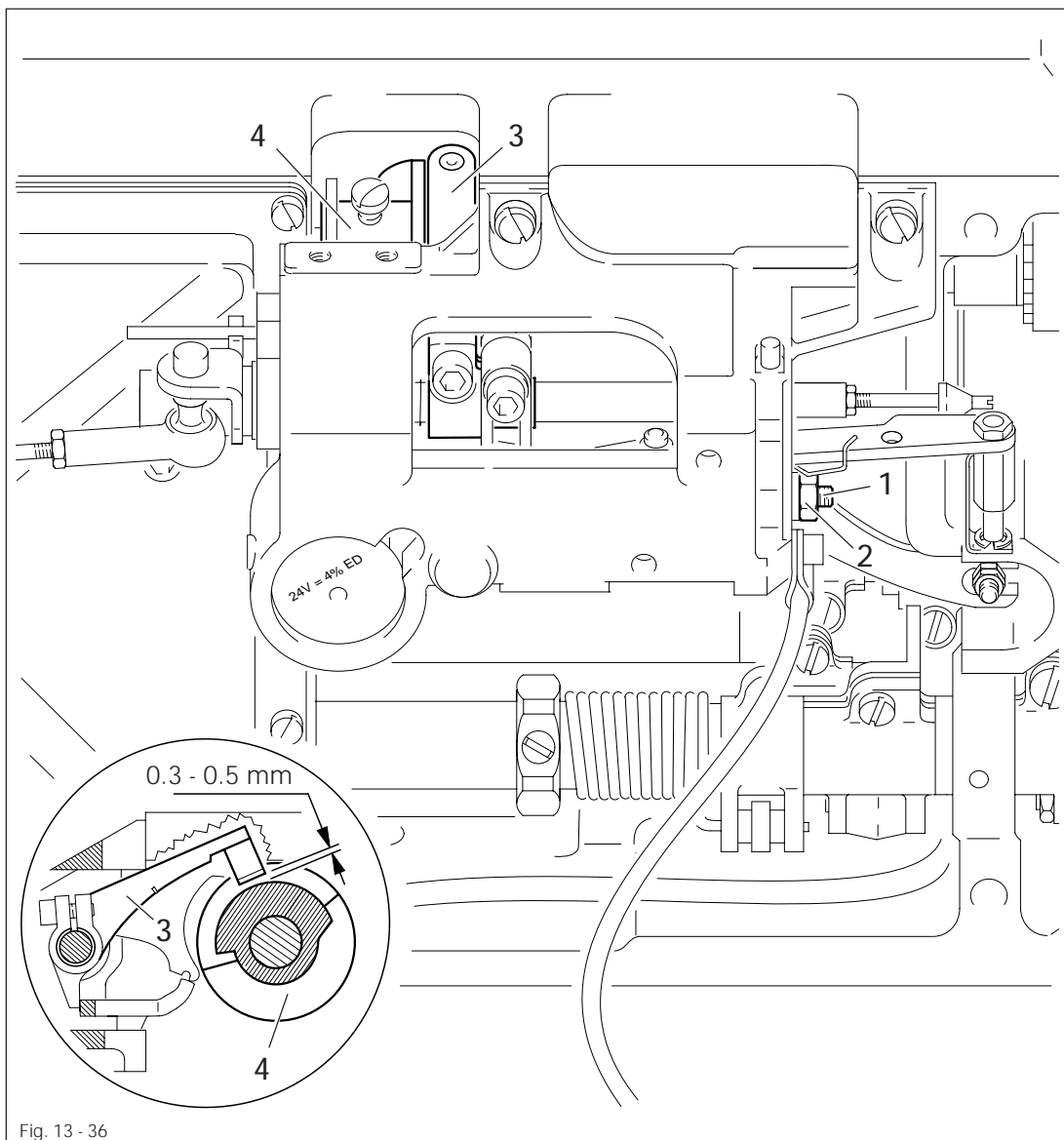

- Turn screw 1 (nut 2) according to the requirement.

## Requirement

A thread which has been inserted twice in the catcher cutout must be cut perfectly when the thread catcher is moved back.

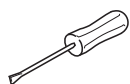
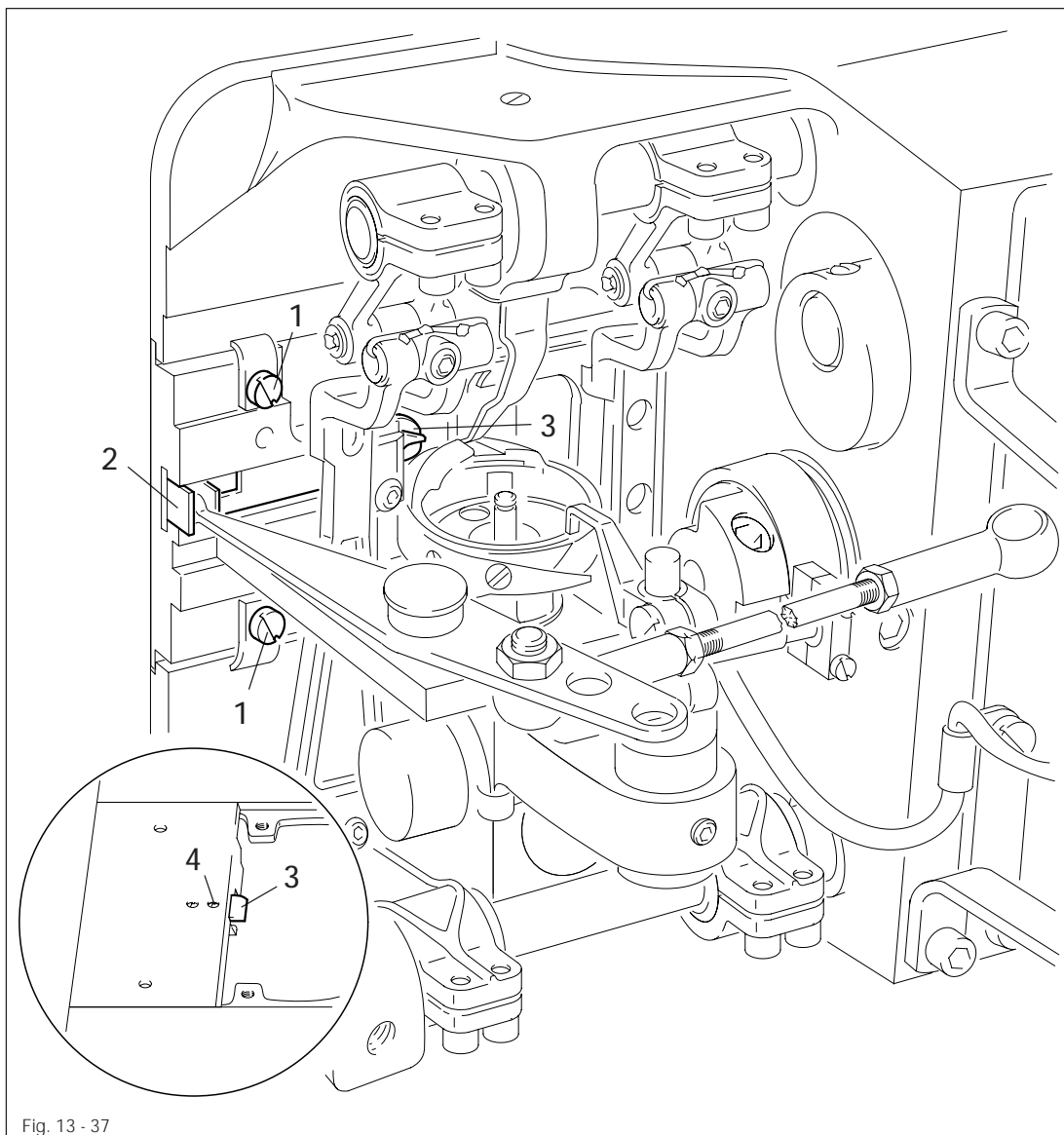

- Remove the entire thread trimmer (screws 1).
- Make sure that the knife blade is in perfect condition.
- Move the thread catcher 2 by hand over the knife 3, until the cutout in the thread catcher 2 can be seen.
- Insert a thread twice in this cutout and move back the thread catcher 2. Both threads must be cut perfectly.
- If the threads are not cut perfectly, increase the knife pressure by screwing in screw 4.

## 13.07.09 Thread catcher position

**Requirement**

When the thread trimmer is in resting position, the thread catcher **3** must be flush with the edge of the mounting plate **4**.

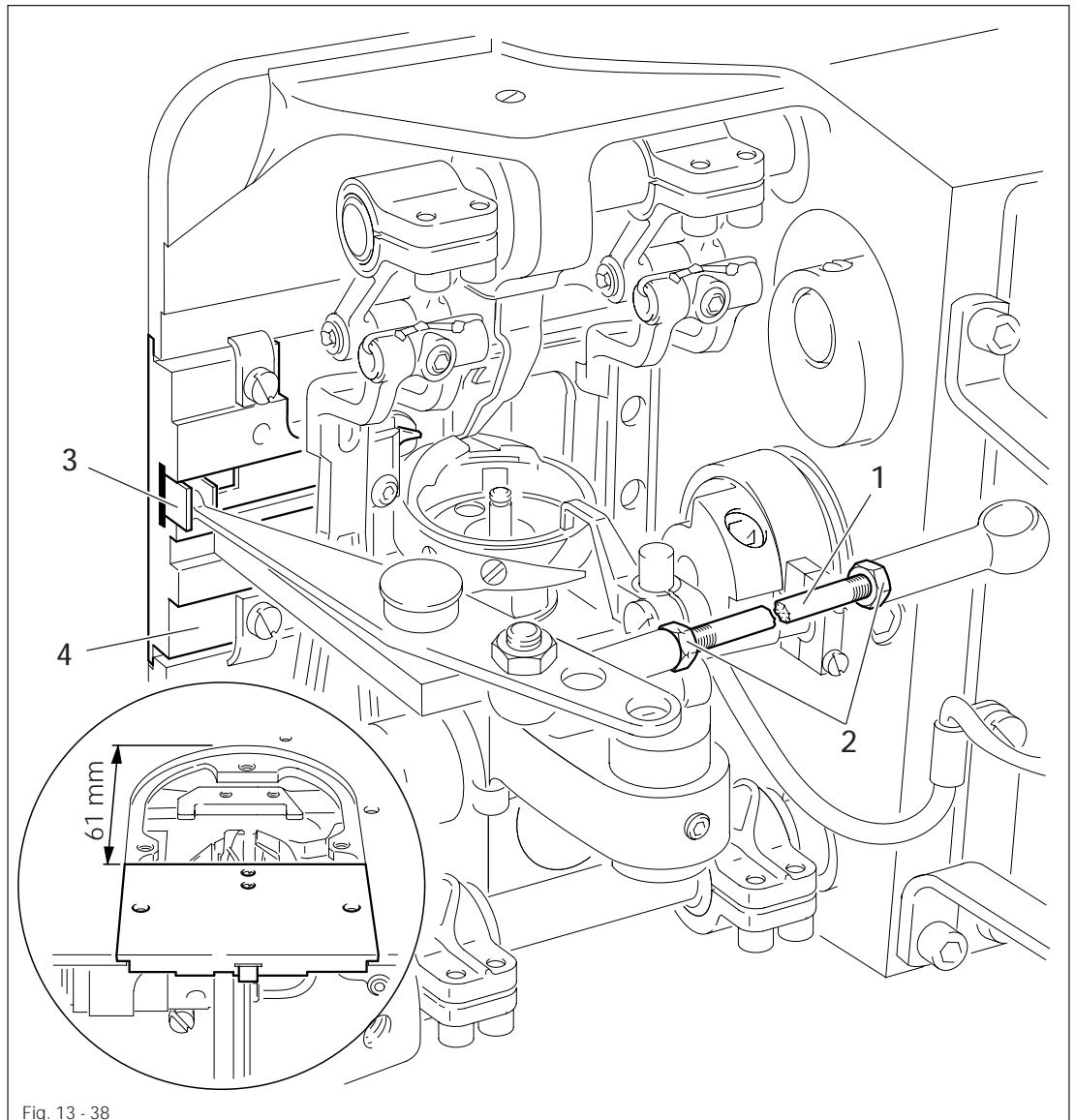
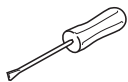

Fig. 13 - 38



- Mount the thread trimmer in the bedplate and align so that the distance between the front edge of the thread trimmer and the back edge of the needle plate cutout is **61 mm**.
- Turn connecting rod **1** (nuts **2**, left and right-hand thread) according to the **requirement**.

## 13.07.10 Control cam (final adjustment) and catch spring

### Requirement

1. When the back edge of the thread guard **6** has just moved **6 mm** past the center of the bobbin case position finger **7**, the thread catcher **8** is to begin with its forward motion.
2. When the thread trimmer is in resting position, there must be a distance of **0.2 mm** between the catch spring **4** and the roller lever **9**.

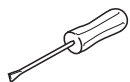
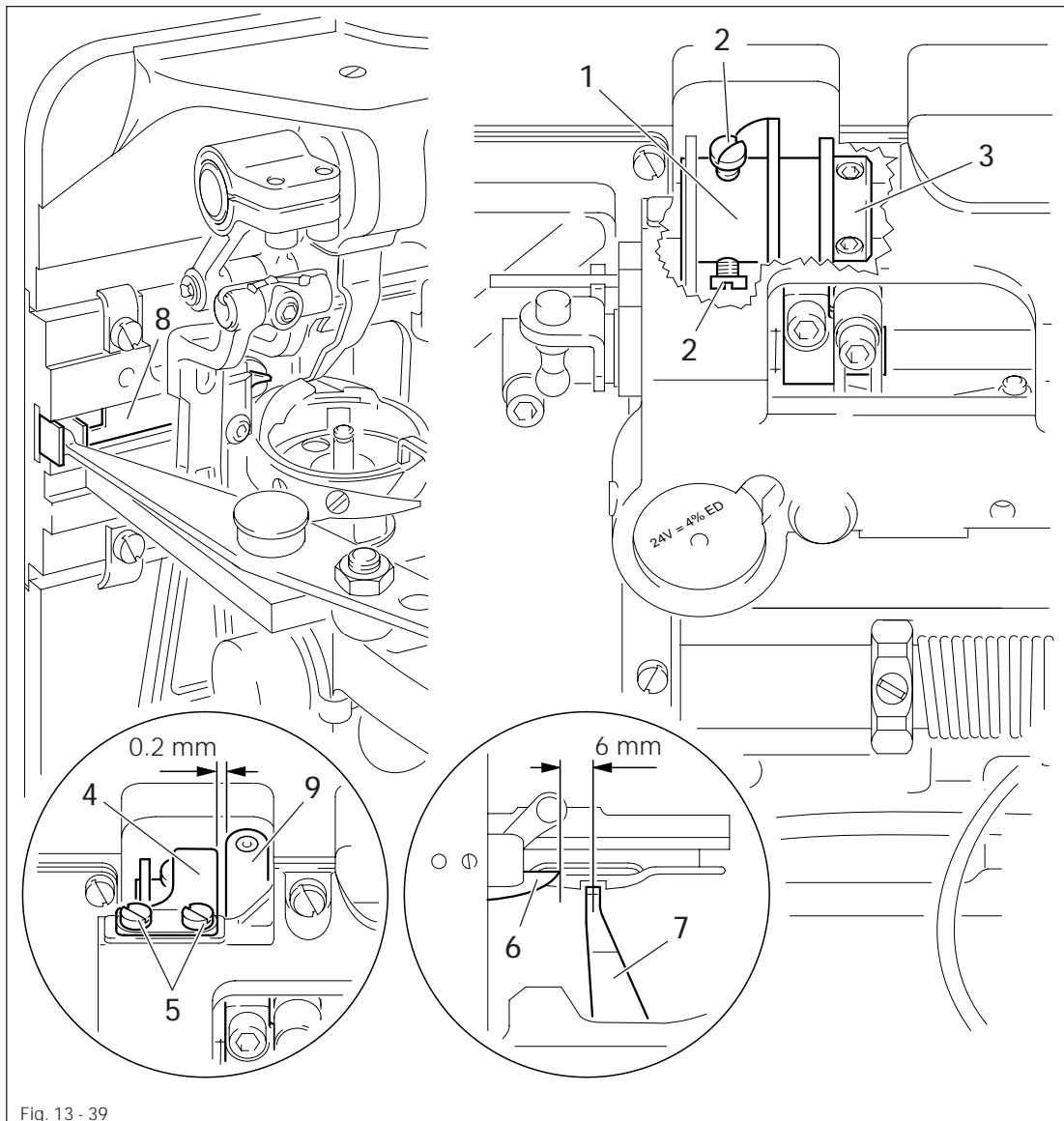

- Bring needle bar to BDC.
- Operate engaging lever.
- Adjust the control cam **1** (screws **2**) according to **requirement 1** and move it against retaining collar **3**.
- Mount catch spring **4** together with the cover disk and screw on screws **5** slightly.
- Slide catch spring **4** up as far as it will go and align according to **requirement 2**.
- Tighten screws **5**.

## 13.08 Adjusting the folding and feed devices

## 13.08.01 Adjusting the switch vanes on the X/Y control

**Requirement**

The overlap of the switch vanes 1 and 3 to the carrier

1. is to be **18 mm** on the carriage for the Y direction.
2. is to be **15 mm** on the carriage for the X direction.

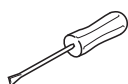
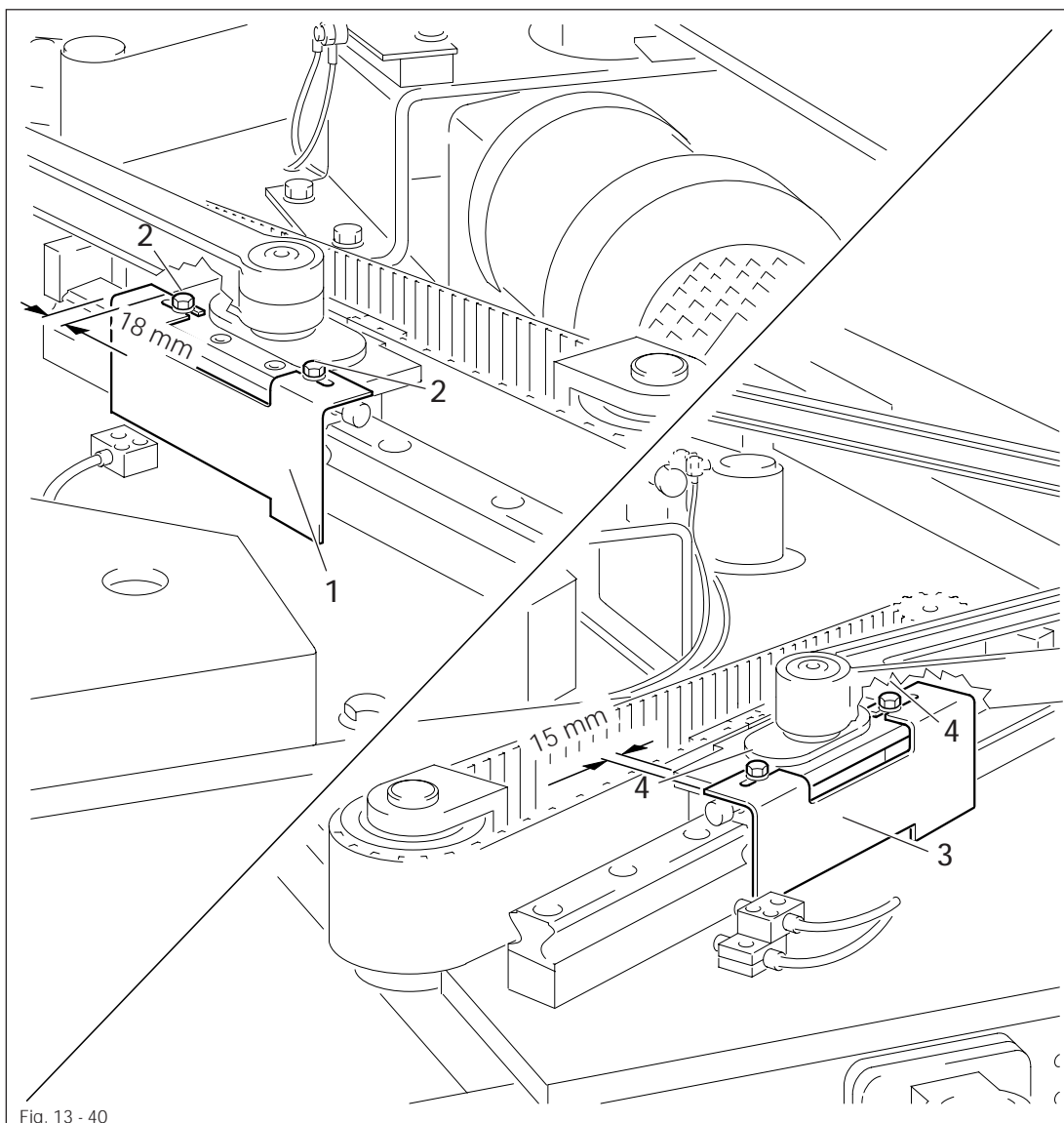

Adjusting the switch vanes 1 and 3 is only necessary when the carriage guides have been replaced or when the zero point setting causes problems.

- Move switch vane 1 (screws 2) according to **requirement 1**.
- Move switch vane 3 (screws 4) according to **requirement 2**.
- Set zero point (see **chapter 9.02.02 Adjusting zero point**).

## 13.08.02 Home position of the transport arm

### Requirement

When lowered, the distance between the upper edge of the transport arm 4 and the machine table at both end positions must be 100 mm.

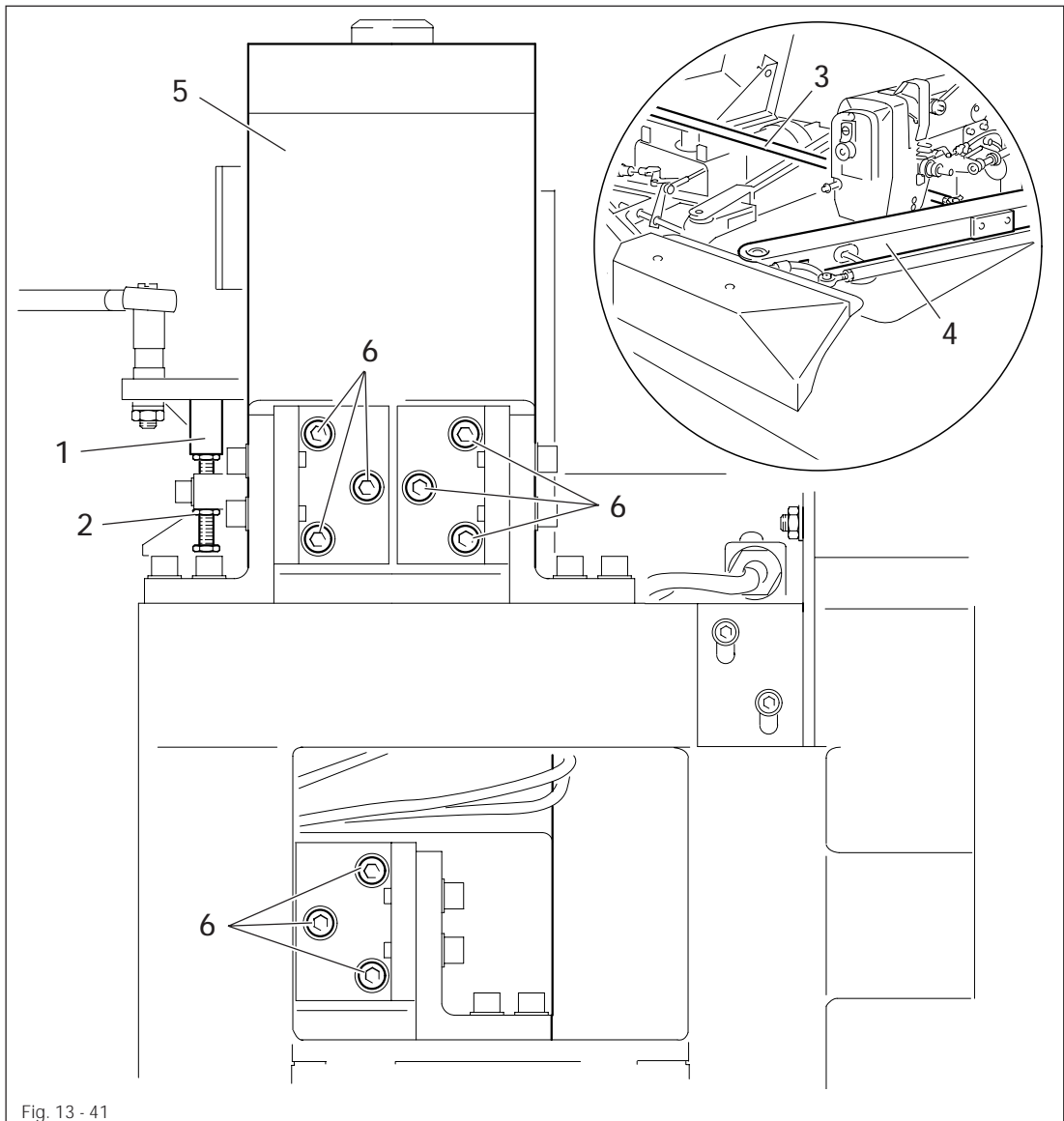
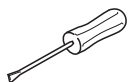

Fig. 13 - 41



- Turn stop 1 (nut 2) according to the **requirement**.
- Detach pull rod 3.
- Swing transport arm 4 to folding station.
- Align carrier 5 (screws 6) according to the **requirement**.
- Swing transport arm 4 back to the sewing station and recheck the distance to the machine table.
- Repeat this adjustment if necessary.
- Connect pull rod 3.



## 13.08.03 Feed changeover

**Requirement**

1. The jig frame must just touch the sewing changeover and be both parallel and horizontal.
2. On the folding station, the sewing jig must be positioned parallel to the pocket plate and/or to the table.
3. When the jig changes over, the jig frame must not move.

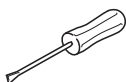
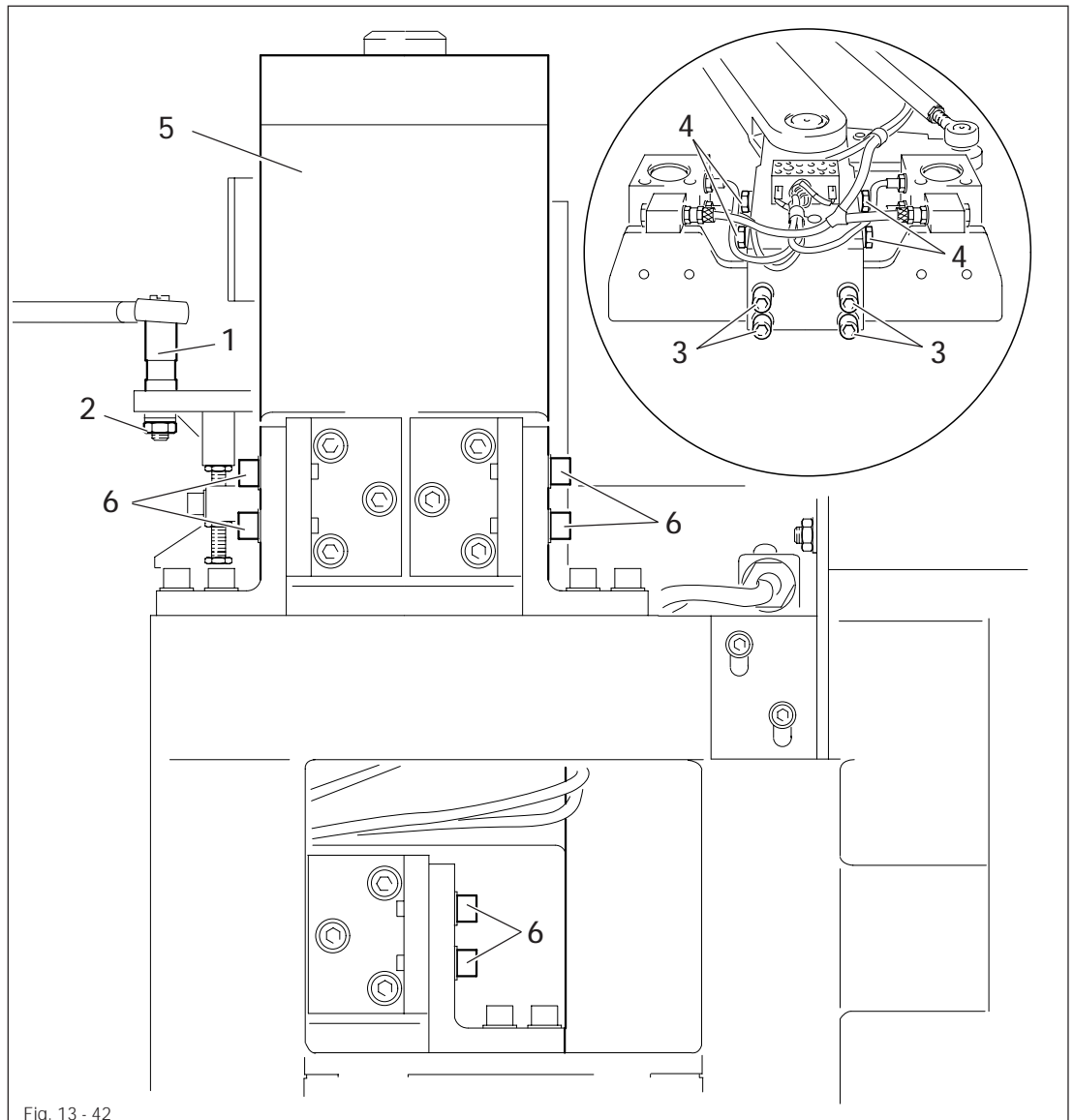

- Move eccentric pin 1 (nut 2) according to the **requirements 1 and 2**.
- Repeat this work step until both adjustments are correct.
- Align jig frames (screws 3 and 4) horizontally.
- Adjust carrier 5 (screws 6) according to **requirement 3**, making sure that the home position of the transport arm does not change (see **chapter 13.08.02 Home position of the transport arm**).

## 13.08.04 Sewing jig position at the sewing station

### Requirement

When the sewing jig is at the sewing station (left end position),

1. rod 3 and crank 6 must be aligned, and
2. the jig frame must be resting against the sewing changeover without pressure.

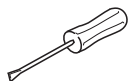
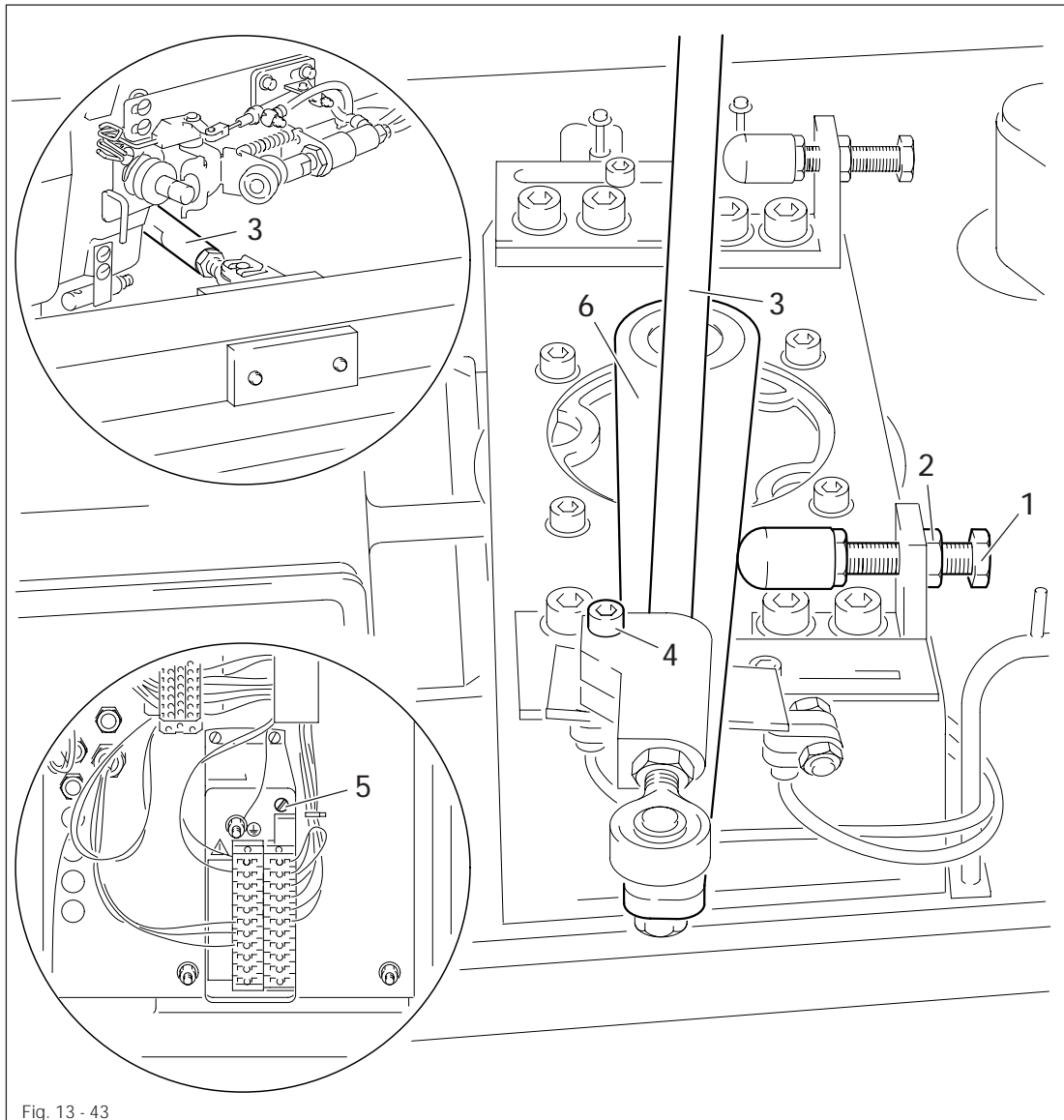

- Turn stop screw 1 (nut 2) according to **requirement 1**.
- Adjust rod 3 (screw 4) according to **requirement 2**.



The feed speed of the sewing jig as it travels to the sewing station can be changed at screw 5 located to the bottom right in the control box. The swinging speed to the folding station cannot be altered.

## 13.08.05 Aligning the sewing jig

### Requirement

The needle must not touch the edges of the sewing jig groove during any phase of the sewing operation.

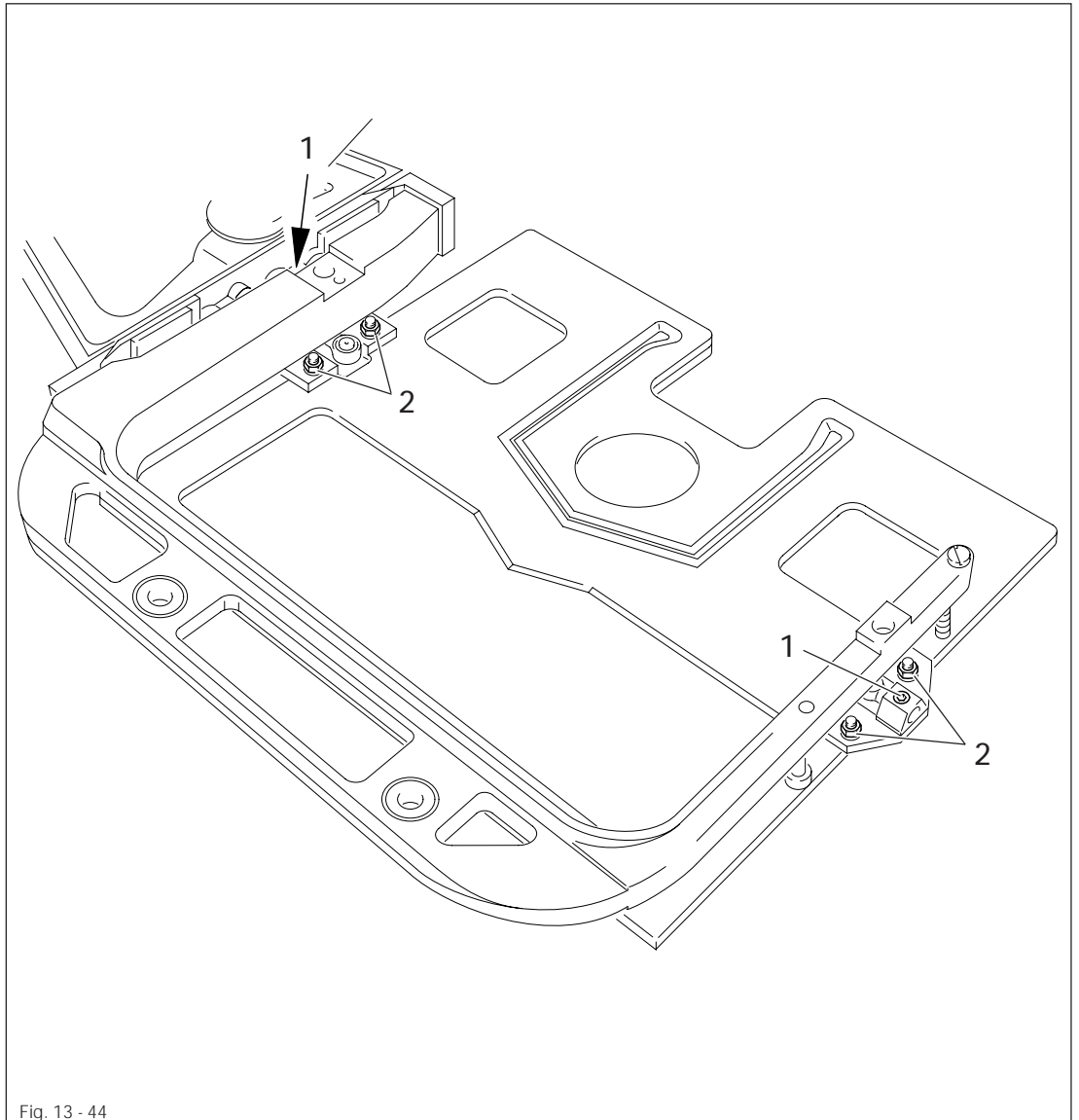
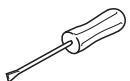

Fig. 13 - 44



- Press the key **seam pattern forwards** until the sewing jig groove is under the needle.
- Position the needle point in the sewing jig groove by turning the handwheel.
- By repeatedly pressing the keys **seam pattern forwards** and/or **seam pattern backwards**, execute the seam pattern.
- Align the sewing jig (screws **1** and nuts **2**) according to the **requirement**.
- By pressing the key **home position**, bring the sewing jig to starting position.

## 13.08.06 Sewing jig position at the folding station (home position)

### Requirement

When the sewing jig is positioned at the folding station (right end position),

1. rods **6** and **7** must be aligned with each other, and
2. the distance of the sewing jig **1** to the right side of the table **8** must be parallel **25 mm**.

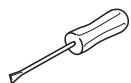
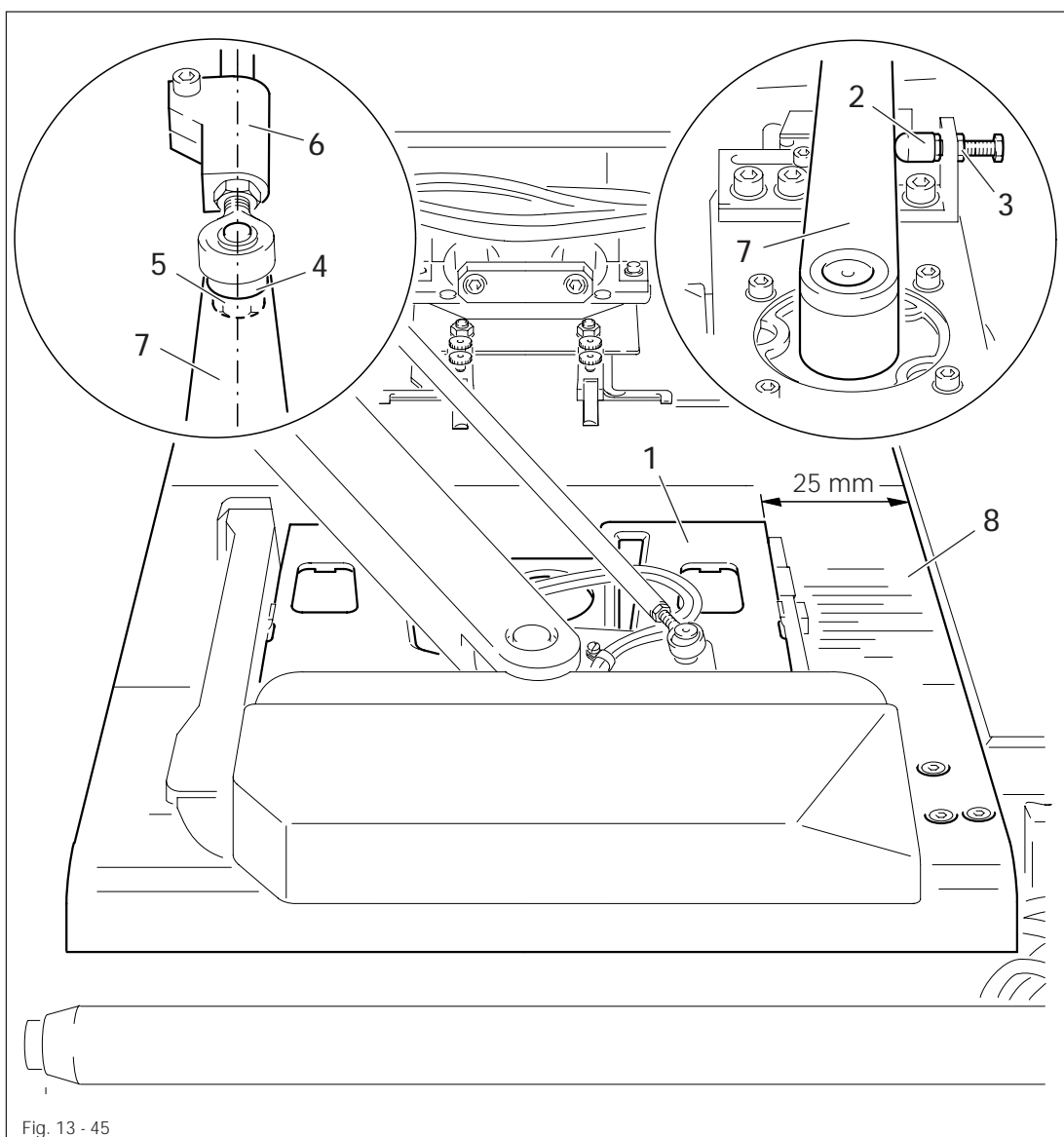

- Swing sewing jig **1** in front of the folding station.
- Turn stop screw **2** (nut **3**) according to **requirement 1**.
- Turn eccentric pin **4** (nut **5**) according to **requirement 2**.
- Recheck left end position of the sewing jig and adjust, if necessary. (See **chapter 13.08.04 Sewing jig position at the sewing station.**)



The exact adjustment of the right end position of the transport arm is based on the pocket seam as described in **chapter 13.08.21 Centering the pocket seam.**

## 13.08.07 Proximity switch

## Requirement

1. In both end positions of the transport arm 9 the corresponding proximity switch 1 or 3 must be covered by 3/4 by the switch vane 10.
2. The distance of the proximity switches 5 and 6 to the proximity switches 1 and 3 must be 46 mm in each case.

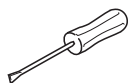
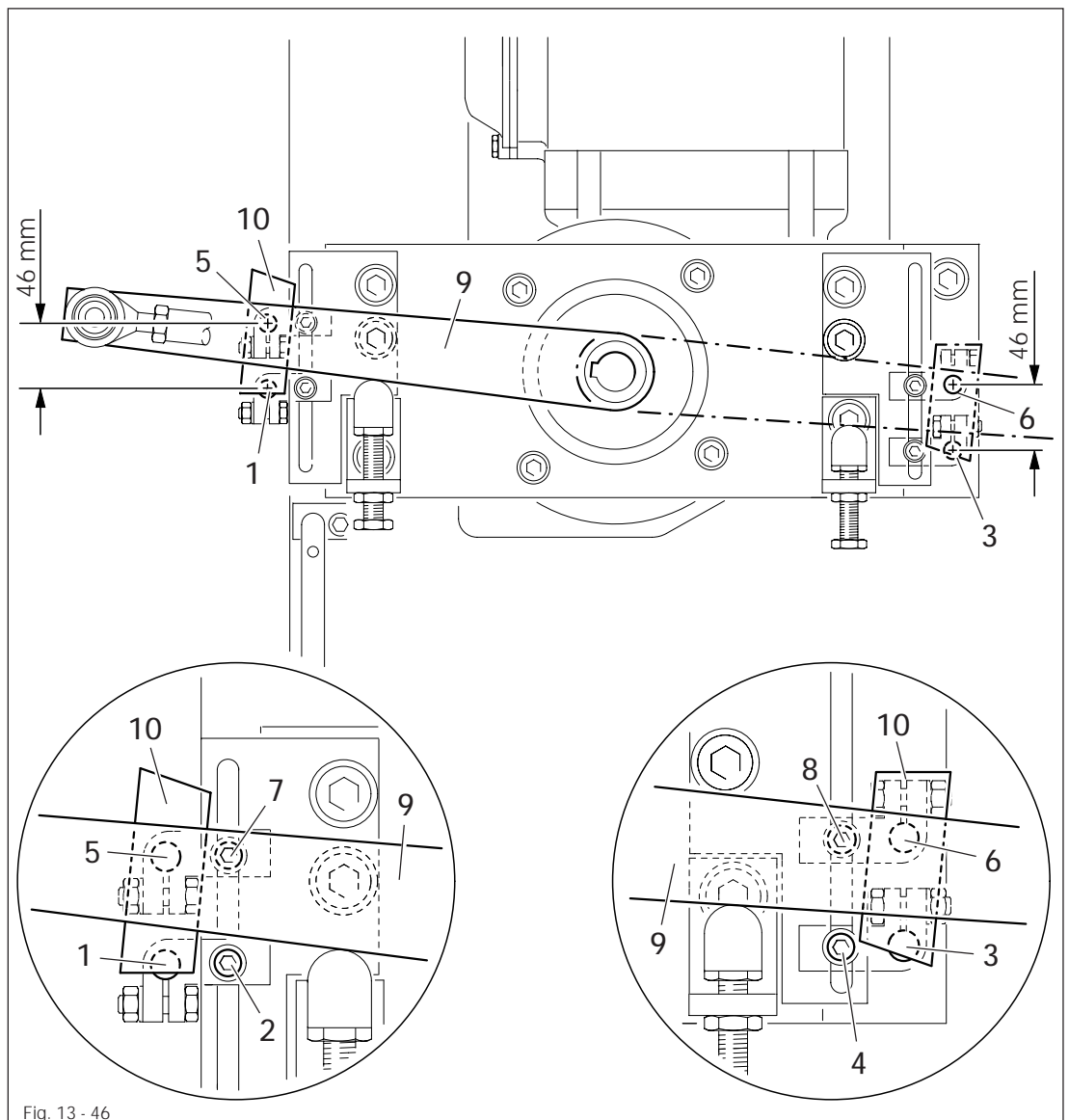

- Swing the sewing jig in front of the sewing station.
- Move proximity switch 1 (screw 2) according to requirement 1.
- Swing the sewing jig in front of the folding station.
- Move proximity switch 3 (screw 4) according to requirement 1.
- Move proximity switches 5 and 6 (screws 7 and 8) according to requirement 2.

## 13.08.08 Height of the table

### Requirement

The table 4 and the insert plate must be at the same height.

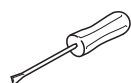
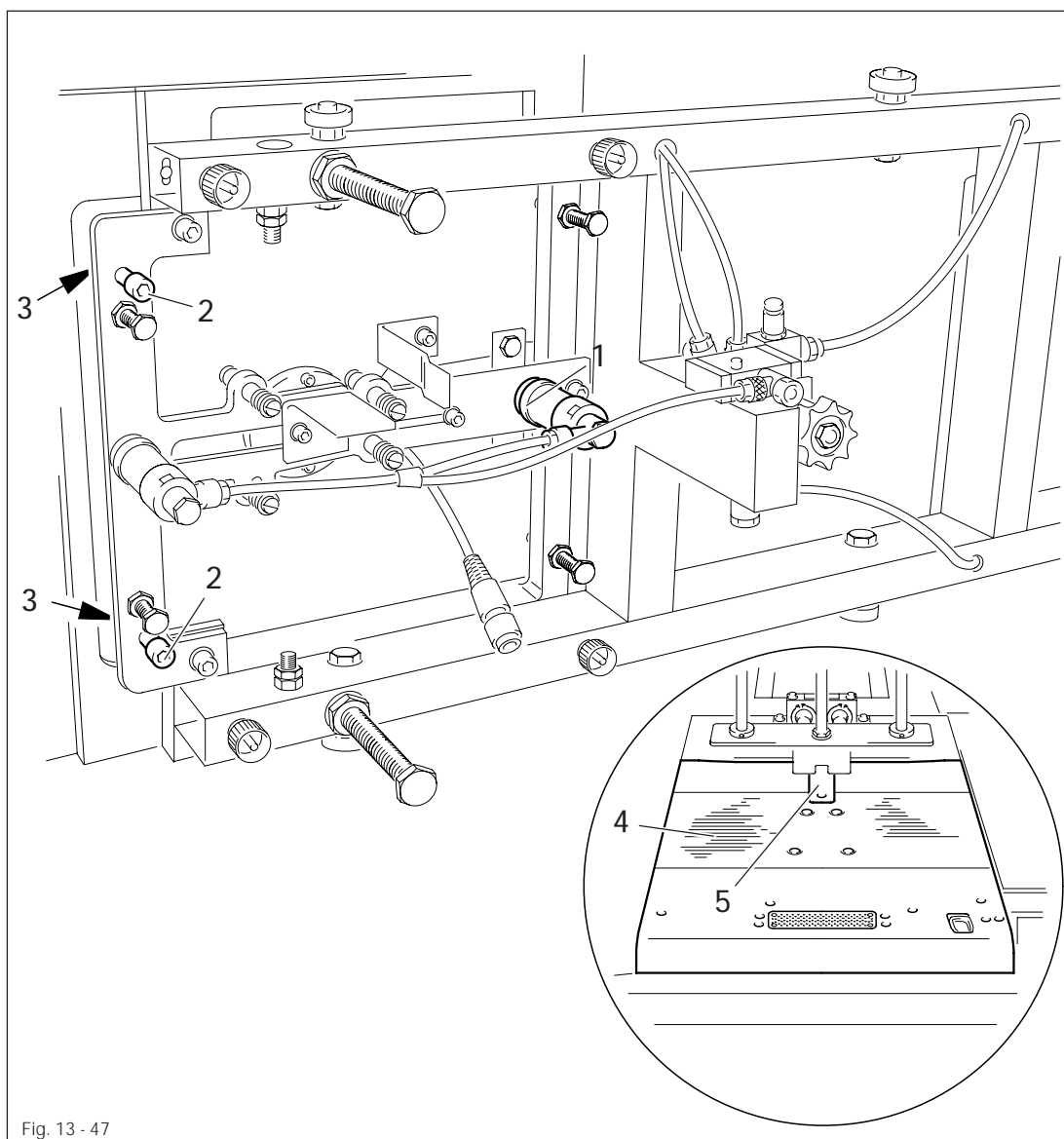

- Turn off compressed air (table is lowered).
- Underneath the table, work loose the lock nut of the plunger from the cylinder 1.
- Open compressed air (table raises).
- By turning screws 2 (lock nut 3) and the plunger of the cylinder 1, adjust the height of the table.
- Turn off compressed air and tighten the lock nut of the plunger.
- Check the free movement of the table 4.

## 13.08.09 Height of pocket plate support

**Requirement**

The plungers **3** must be flush with the raised table **4**.

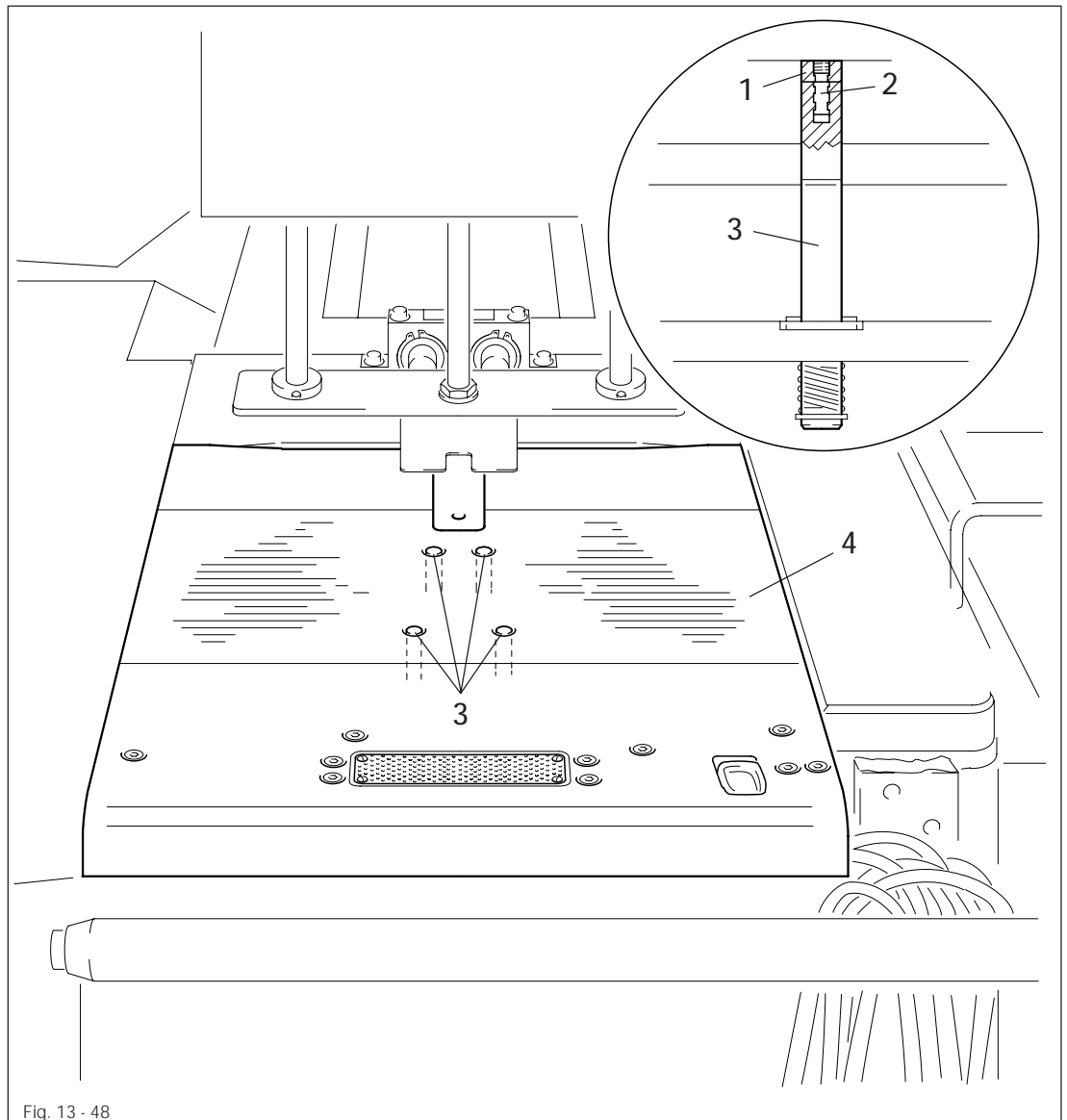
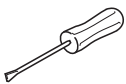

Fig. 13 - 48



- Turn screws **1** (grub screws **2**) according to the **requirement**.



Depending on the size of the pocket plate, the plungers which are not in the pocket plate area can be lowered.

To do this, press the plunger up lightly, turn by **90°** and lower.

## 13.08.10 Basic dimensions of the folder



The folders are mounted according to basic dimensions from the factory. These dimensions may not be changed when adjustments are carried out! Only make adjustments described in this manual!

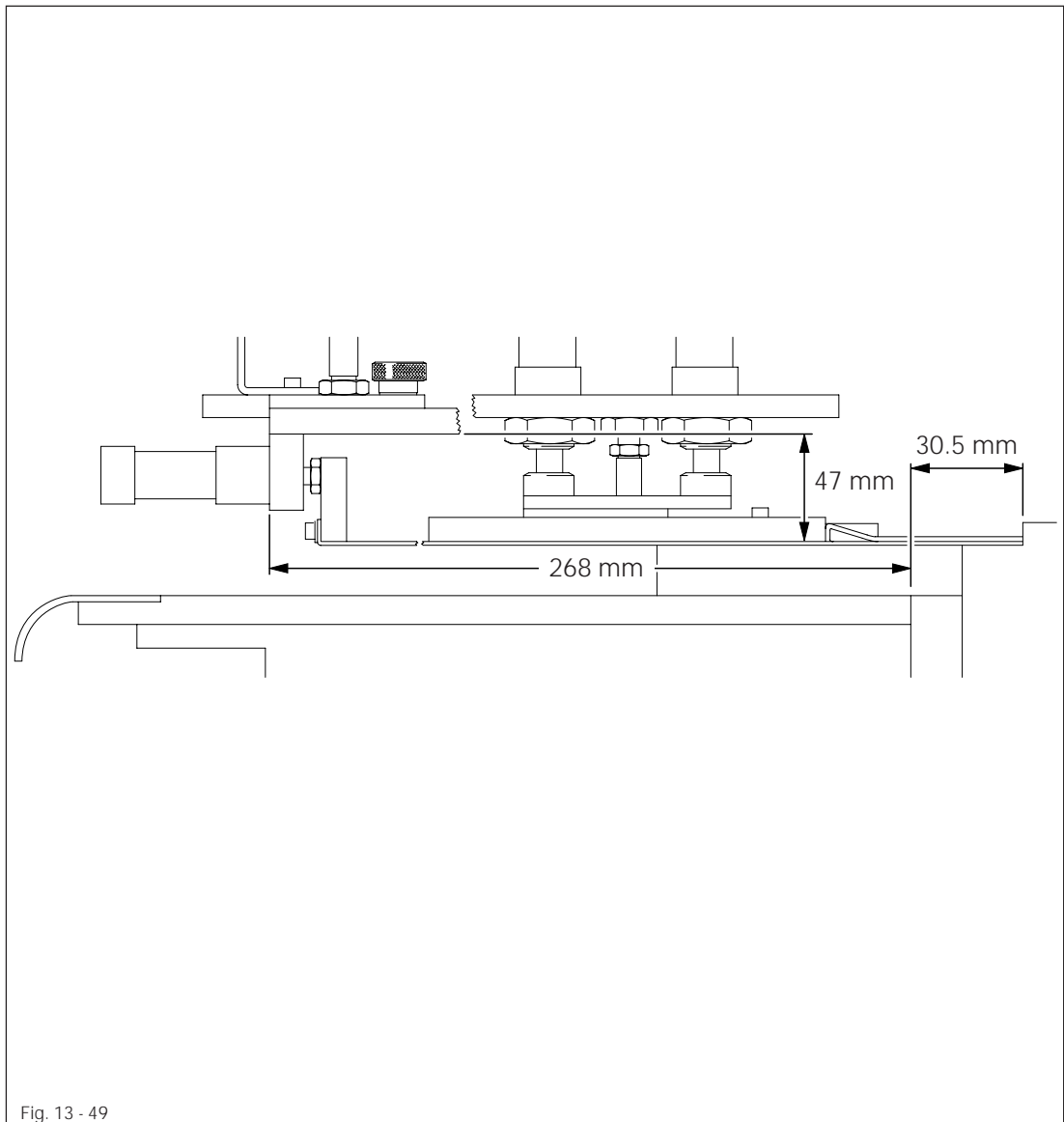

Fig. 13 - 49



## 13.08.11 Height of the folder device

**Requirement**

The folder table and the machine table must be at the same height.

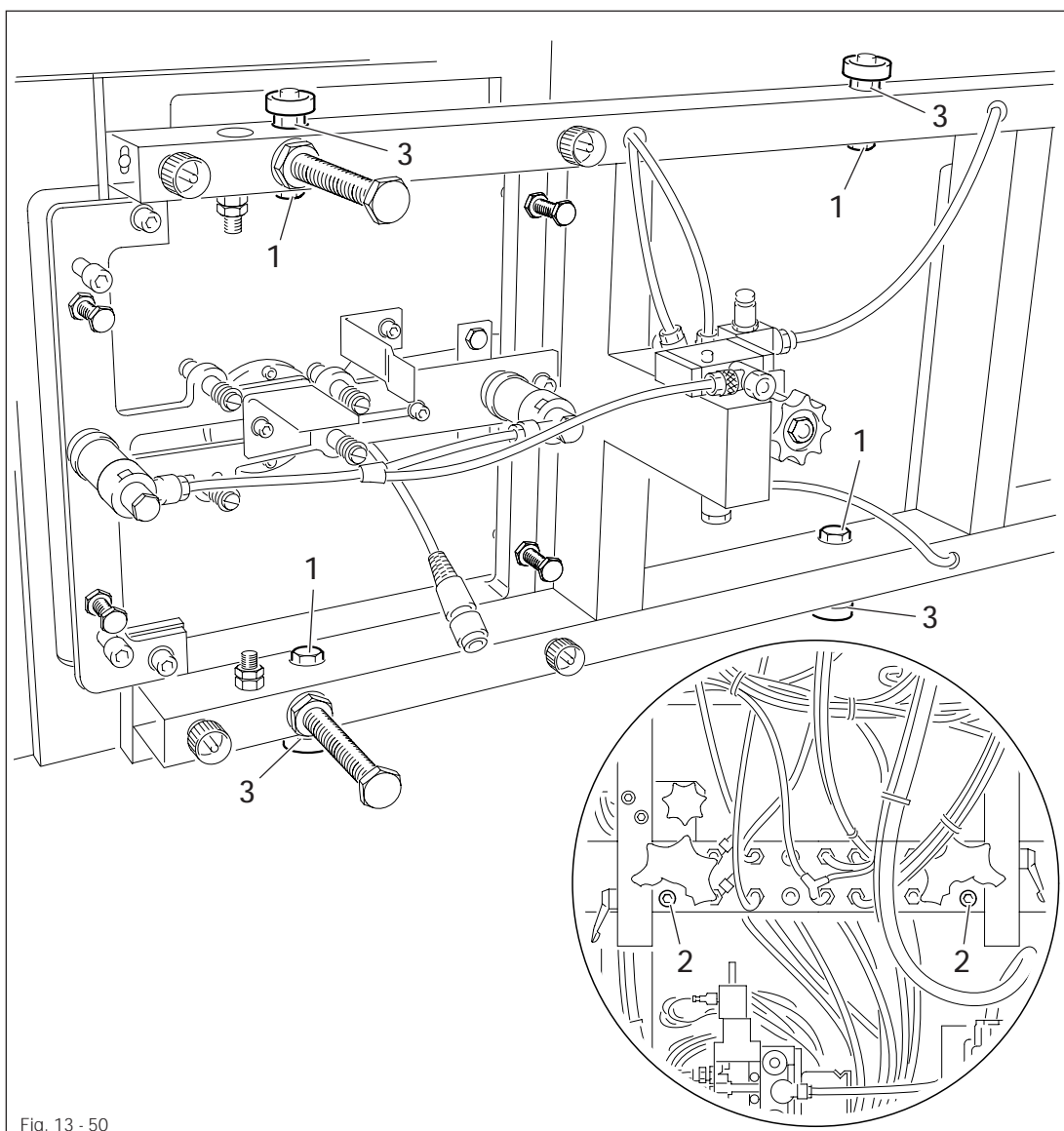
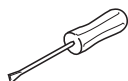

Fig. 13 - 50



- Loosen nuts 1 and screws 2.
- Align folder device by turning eccentric pins 3 according to the requirement.
- Tighten nuts 1 and screws 2.

## 13.08.12 Position of pocket plate arm

### Requirement

1. When the pocket plate **3** is lowered, it must be parallel to the table.
2. The lengthwise motion of the pocket plate **3** must run parallel to the table.

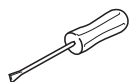
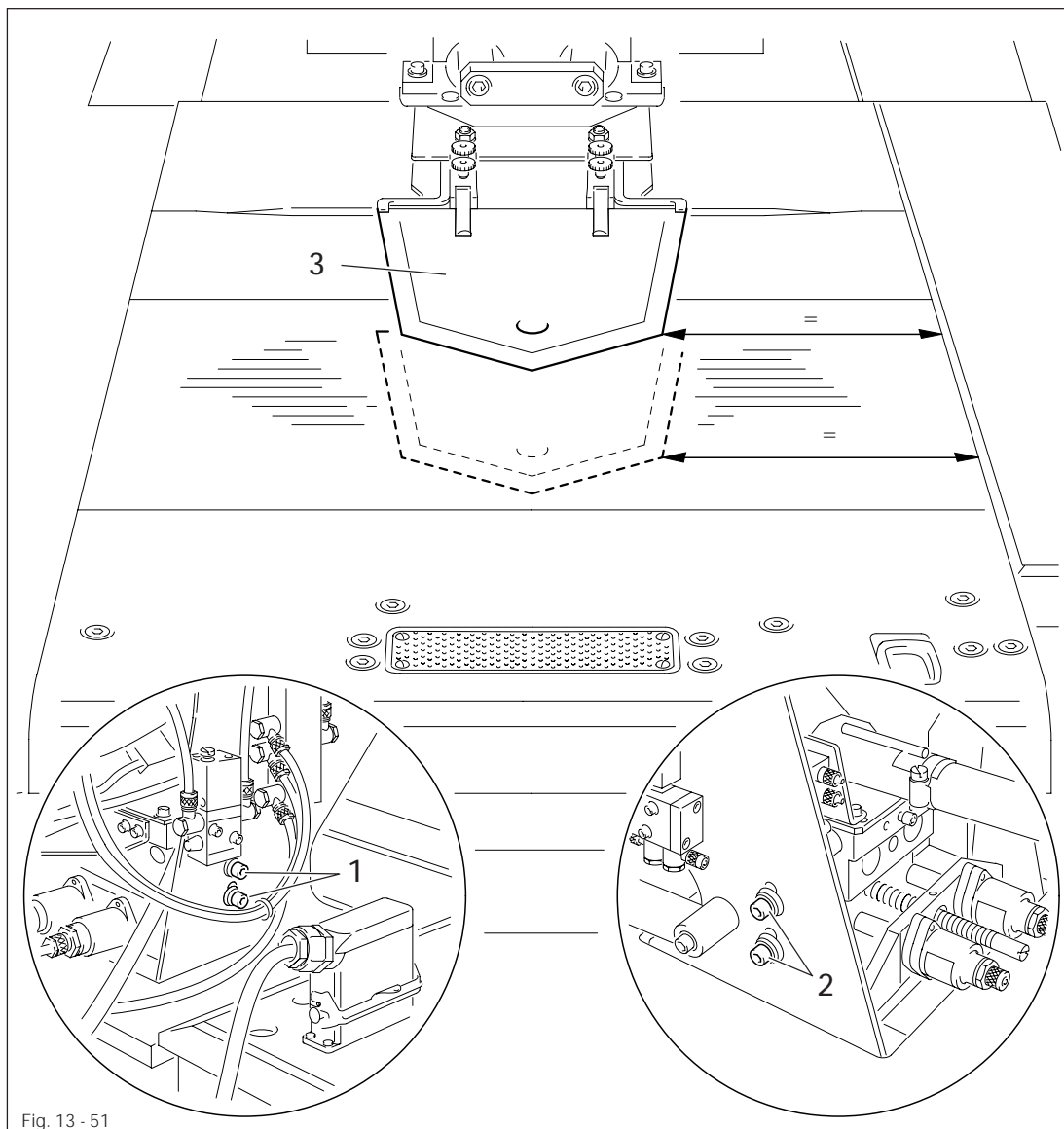

- Loosen screws **1** and **2** just enough so that the bearing housing of the pocket plate arm can only be moved with difficulty.
- Align pocket plate arm by moving the bearing housing according to **requirement 1**.
- Turn off compressed air.
- Remove pocket plate **3** and measure the distance to the edge of the table.
- Move pocket plate **3** back a little and measure the distance to the edge of the table again.
- If both distances are not equal, align the pocket plate arm according to **requirement 2**.
- Check **requirement 1** and realign pocket plate arm if required.
- Tighten screws **1** and **2**; turn on compressed air.

## 13.08.13 Pocket plate position

**Requirement**

The pocket plate **1** must be centered and parallel to the table.

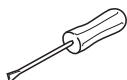
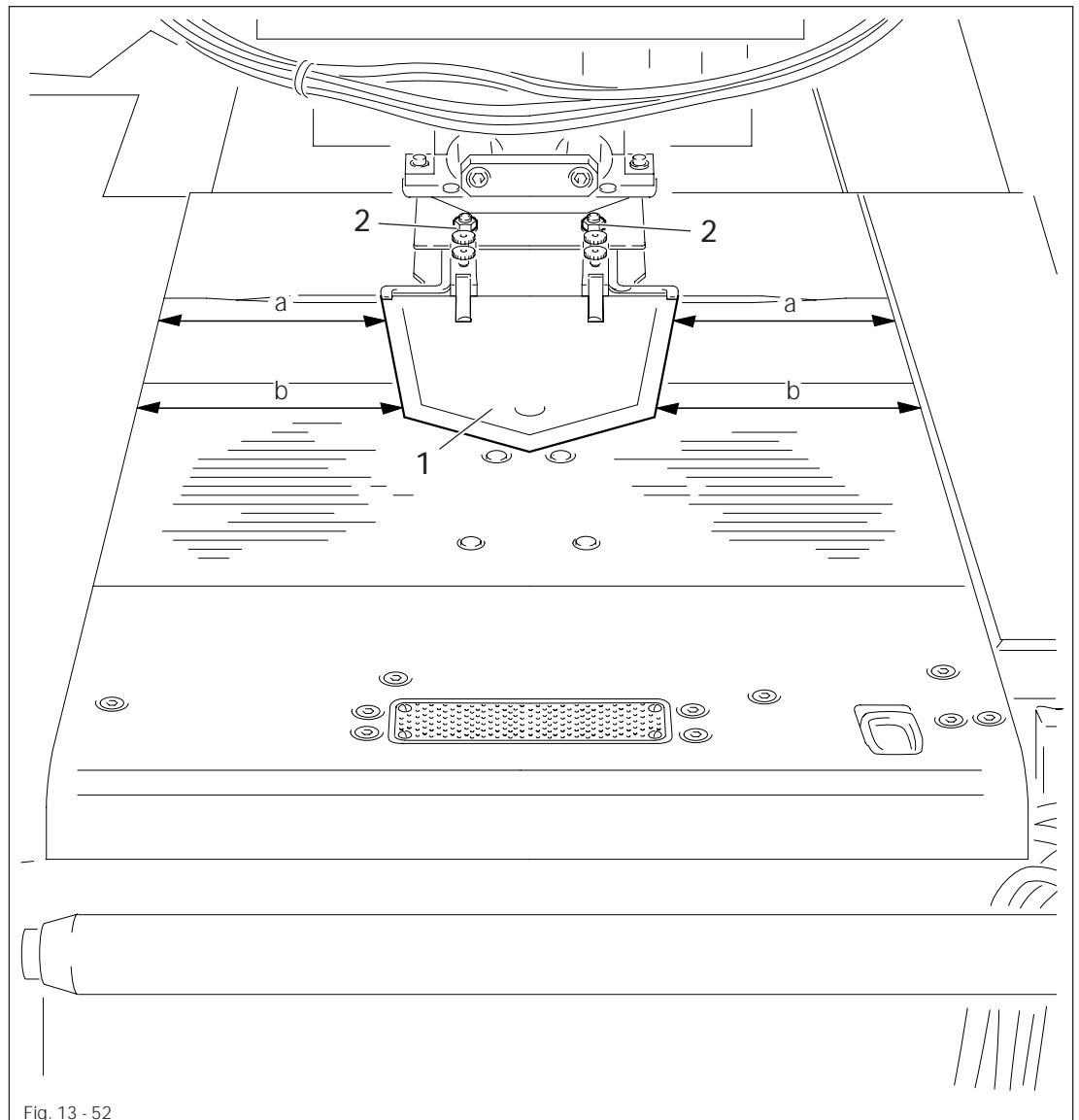

- Align the pocket plate **1** (nuts **2**) so that measurements **a** are the same. The same applies to measurements **b** correspondingly.

## 13.08.14 Pocket plate height

### Requirement

1. When the pocket plate is in home position, the distance to the table must be 11 to 12 mm.
2. When the pocket plate is raised, it must be possible to easily move a panel of fabric positioned under the pocket plate.
3. When the pocket plate is lowered, it must just touch the fabric positioned under it; it must not apply pressure to the fabric, however.

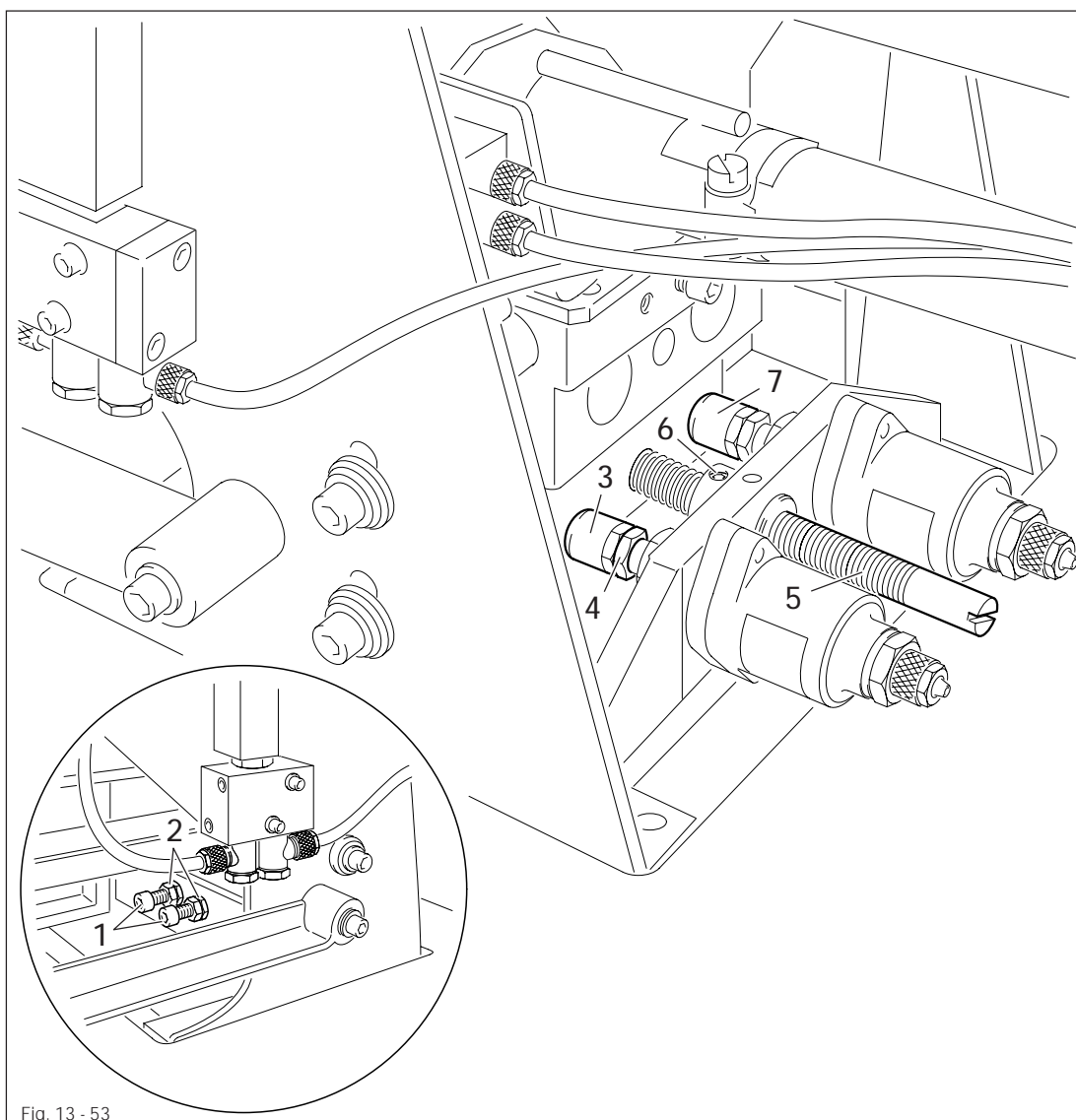
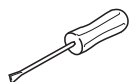

Fig. 13 - 53



- Turn screws 1 (nuts 2) according to requirement 1.
- Turn stop 3 (nut 4) according to requirement 2.
- Turn adjusting screw 5 (screw 6) according to requirement 3.
- Grease stops 3 and 7.

13.08.15 Die

## Requirement

1. The die 2 together with its angular strip 8 must lie evenly on the table.
2. The bottom edges of the angular strips 8 must be at a distance of approx. the thickness of the fabric under the underside of the pocket plate.
3. The angular strips 8 must be positioned on all sides at the same distance of 0.3 to 1 mm (depending on the fabric) to the pocket plate.

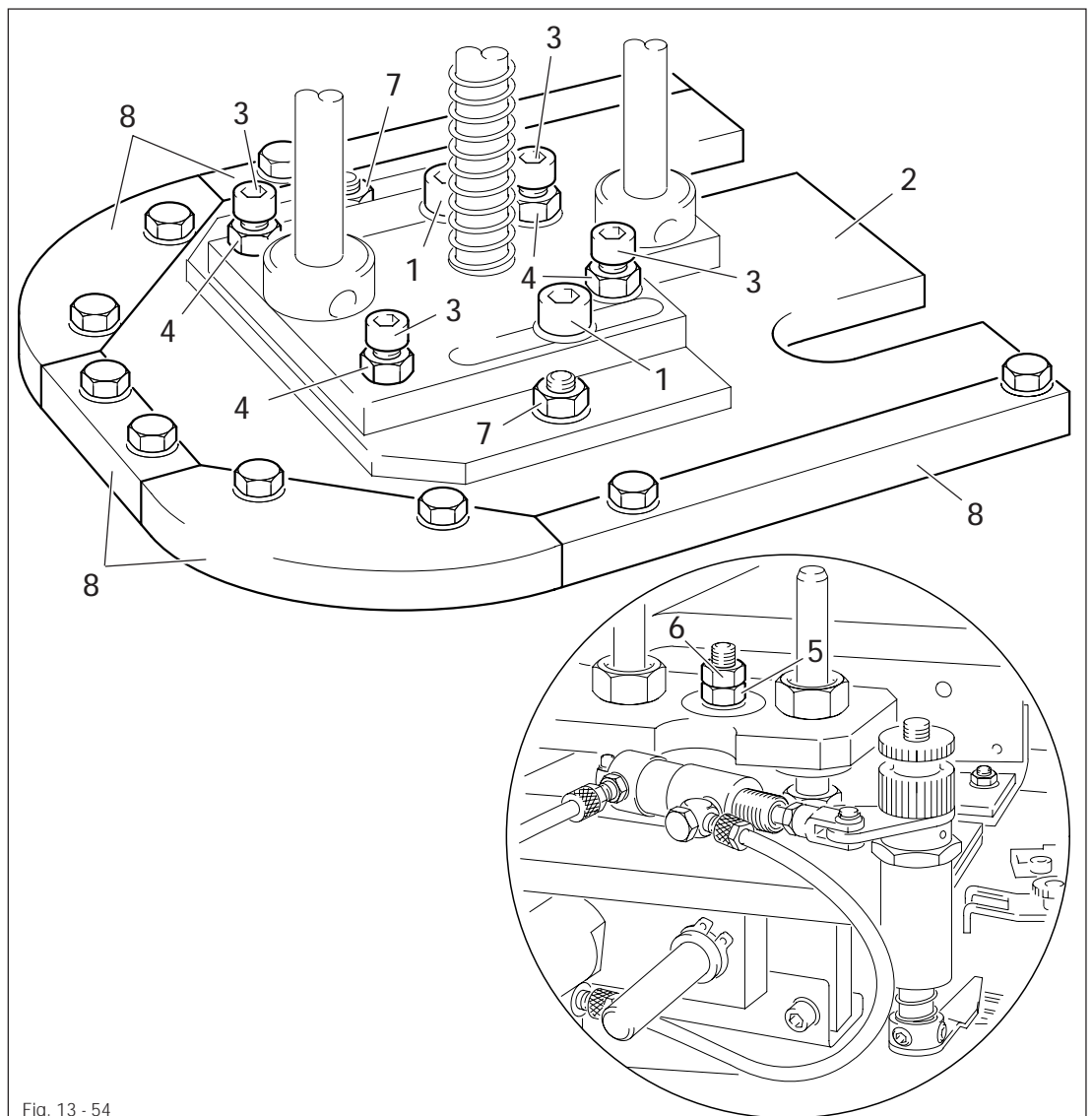
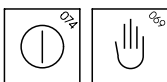
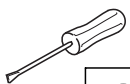

Fig. 13 - 54



- Unscrew folder plates.
- Turn on machine and select **MANUAL** mode.
- Press start controls simultaneously.
- Press **folder movement** key.

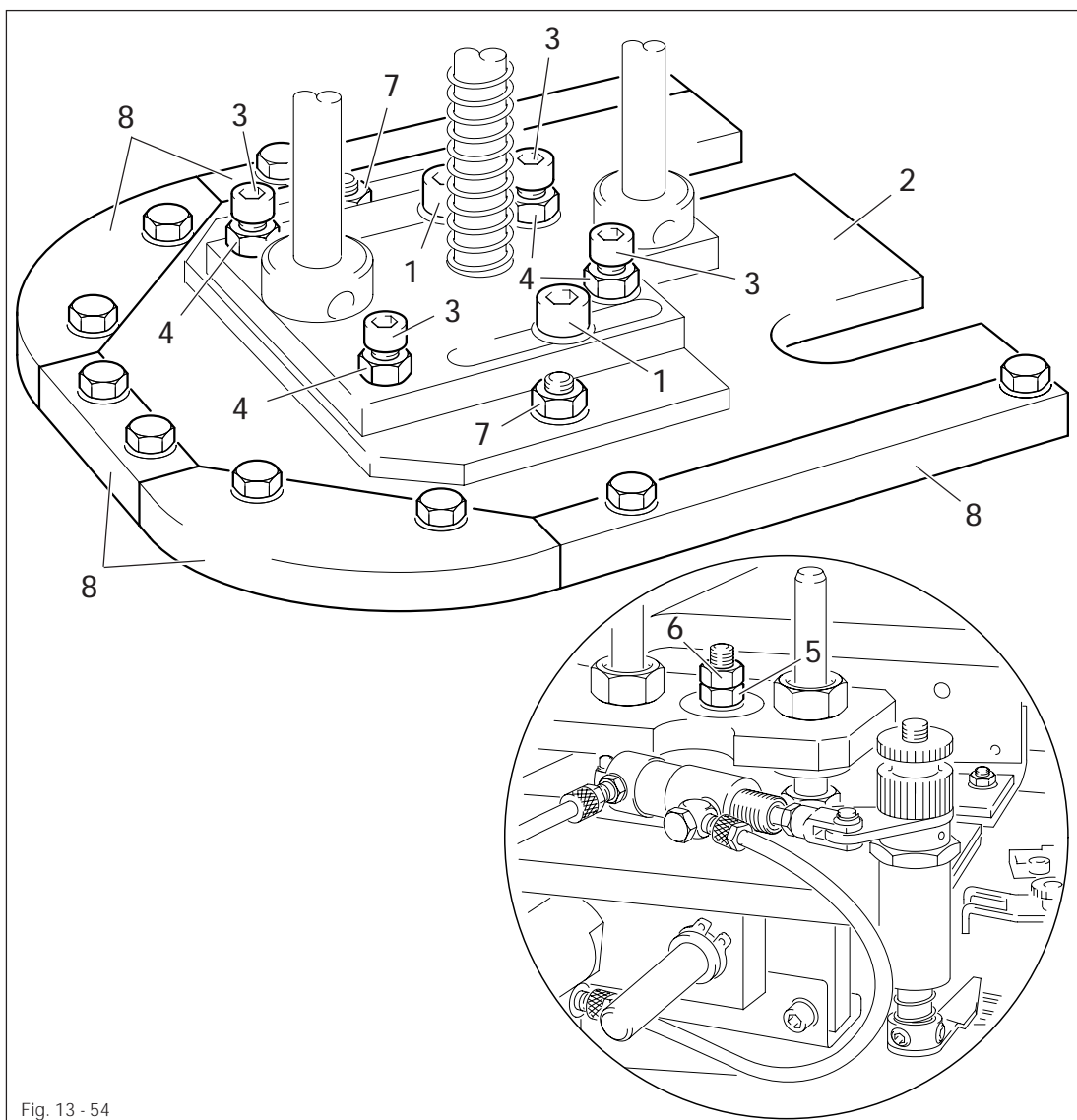
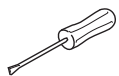

Fig. 13 - 54



- Loosen screws 1 and align die 2 by turning screws 3 (nuts 4) according to **requirement 1**.
- Adjust height of die by turning the nut 5 (lock nut 6) according to **requirement 2**.
- Align die 2 (screws 1, nuts 7) so that its outer edges are flush with the pocket plate edges.
- Align angular strips 8 according to **requirement 3**.



- Bring folder to starting position.
- Screw on folder plates.



To better align die 2 and angular strips 8, place a mirror under the folder unit.

## 13.08.16 Position of folder plate

## Requirement

1. The front edge of the folder plate 2 must be parallel to the die 4.
2. The exiting folder plates 2 must be positioned on all sides approx. 0.1 mm under the lower edge of the angular strips of the die 4.

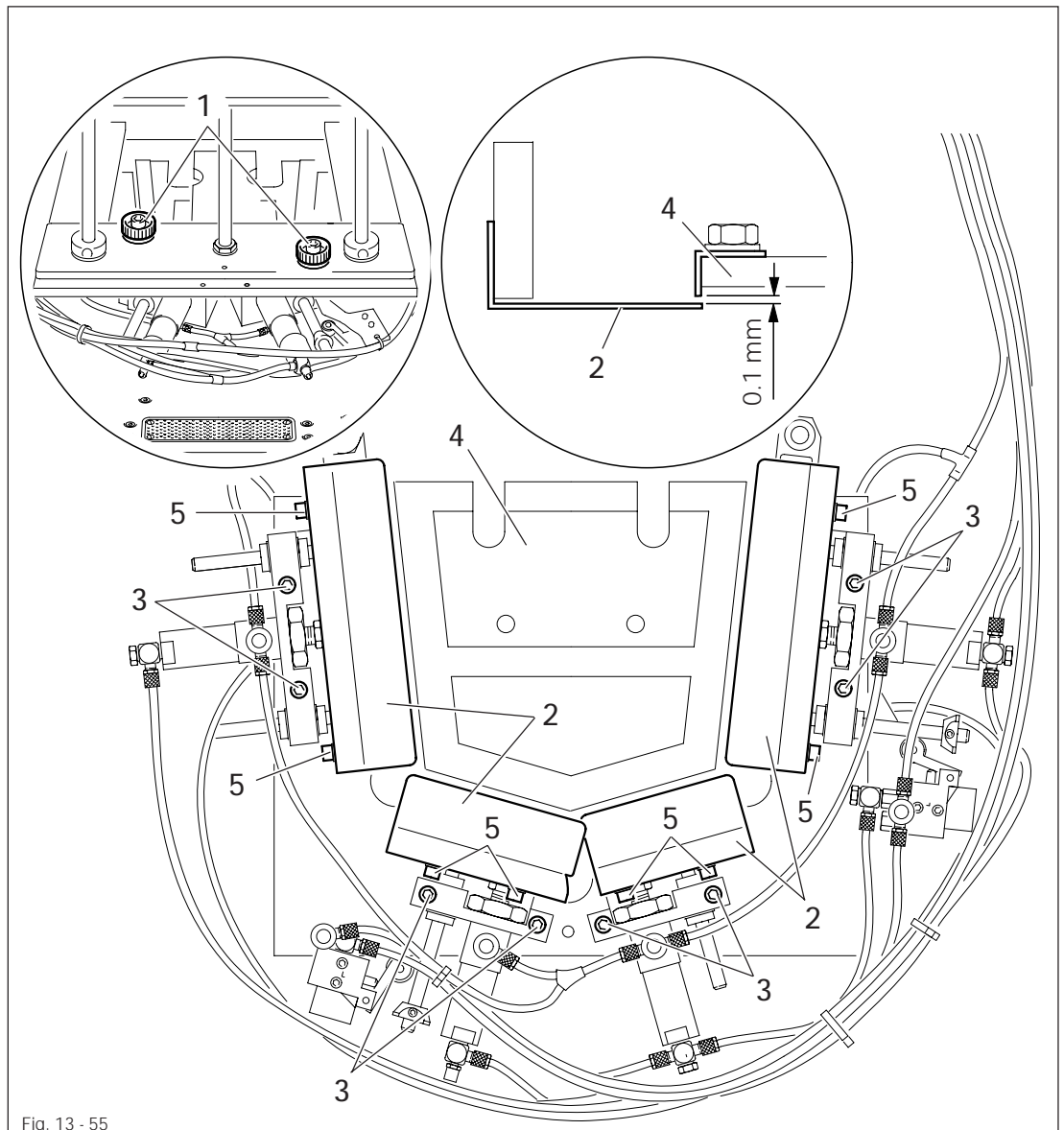
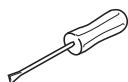

Fig. 13 - 55



- Turn off compressed air and unscrew compressed air connection of the folder unit.
- Unscrew screw 1 and remove the entire folder unit.
- Align folder plate 2 according to **requirement 1** (screws 3).
- Insert folder plate 2 and adjust distance to die 4 according to **requirement 2** (screws 5).
- Position the folder plates of the following switching positions correspondingly under the previous folder plate to be entered (see **chapter 13.08.17 Actuating sequence of the folder plates**).
- Mount the folder unit (observe the aligning pins) and tighten screws 1.
- Screw on compressed air connection and turn on compressed air.

## 13.08.17 Actuating sequence of the folder plates

Pocket style					
1. Switching position	a + b	a + b	a + b	a + b	a + b
2. Switching position	c + d + e	c + d + e	c + d	c + d + e	c + d
3. Switching position	f	f	e	f	e
4. Switching position	g	g	f	g	f
5. Switching position		h			g

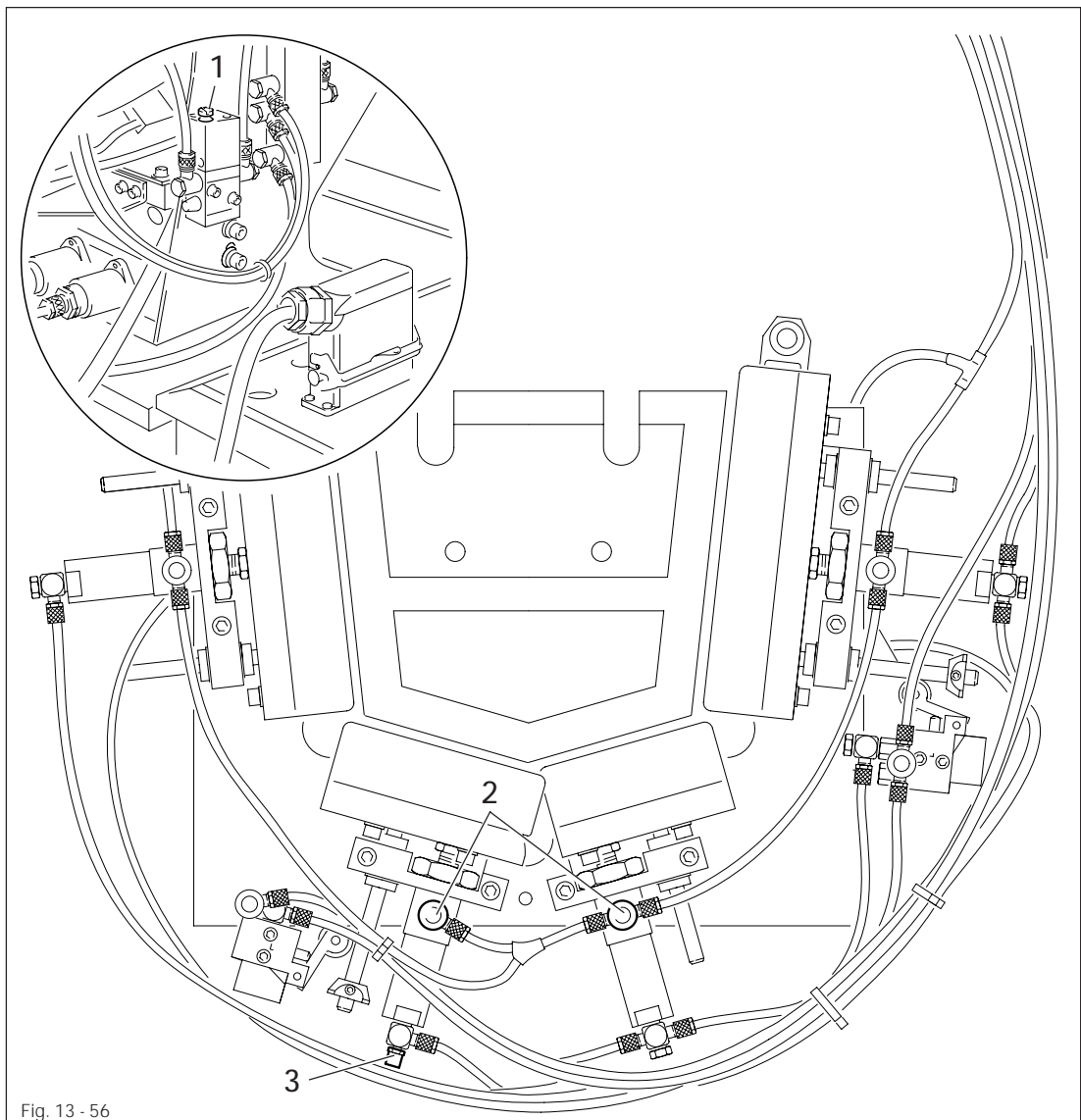
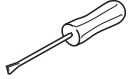

Fig. 13-56



The actuating sequence and the number of folder plates (and the number of switching positions) depends on the pocket style. The folder installation shown in Fig. 13-56 is for the third pocket style. For other pocket styles, refer to the above table for the cylinders corresponding to the relevant switching positions.





- Adjust the entering delay of the folder plates of the second switching position with screw 1.
- Adjust the entering delay of the third, fourth and, if available, fifth switching position on the regulating valves 2 of the corresponding cylinders.
- Adjust the exiting delay of the folder plate of the final switching position on the regulating valve 3 of the corresponding last cylinder.

## 13.08.18 Position of corner folder

### Requirement

1. In folder position, the corner folder 1 must be parallel under the slanted side of the folder plate and overlap by 1 to 2 mm.
2. The corner folders must be positioned 1 to 2 mm under the folder plates depending on the fabric thickness.

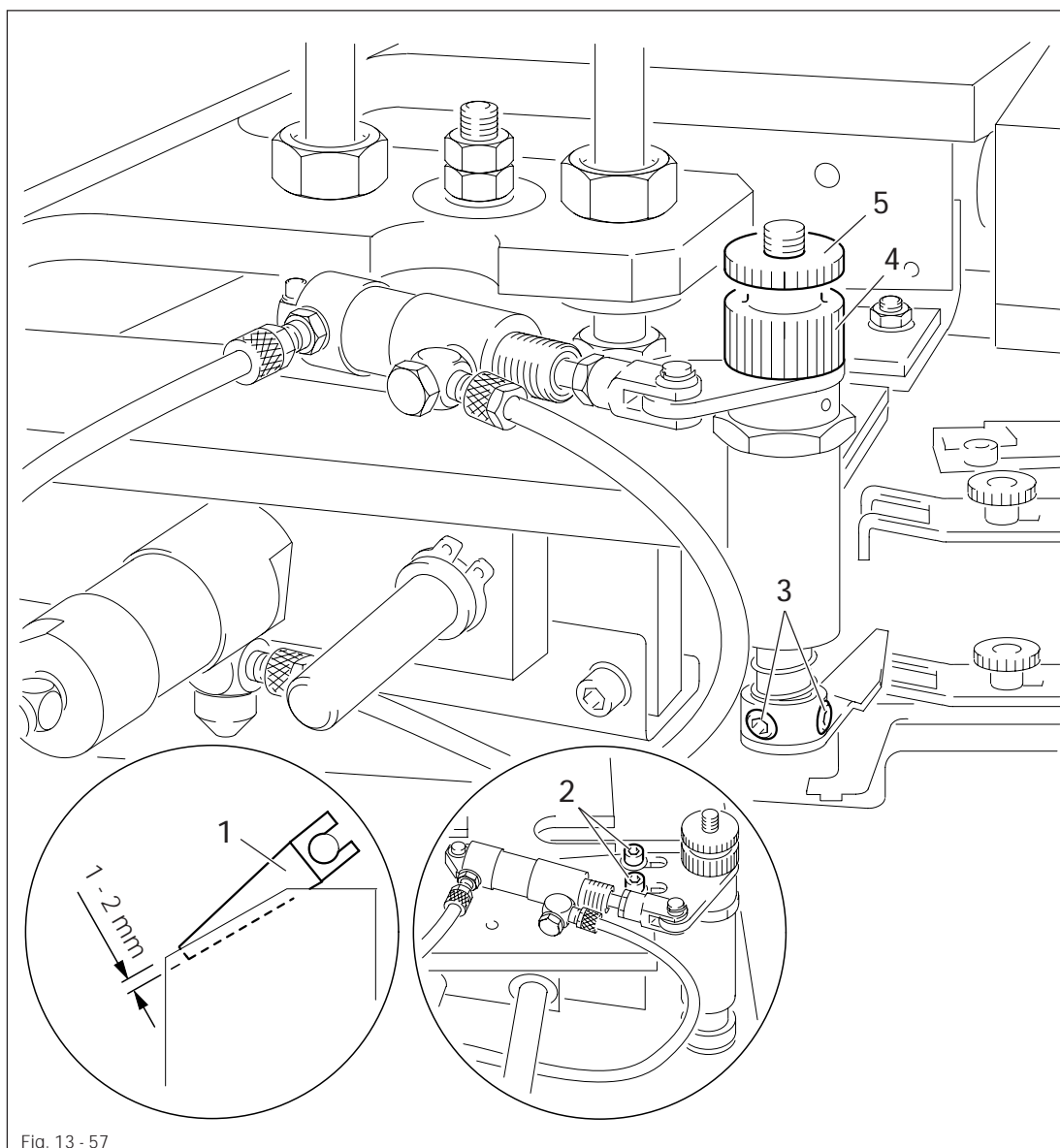
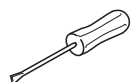

Fig. 13 - 57



- Align the corner folders 1 according to **requirement 1** (screws 2 and 3).
- Turn knurled nut 4 (knurled nut 5) according to **requirement 2**.

## 13.08.19 Roller lever valves

**Requirement**

The roller lever valves **3** are not to be actuated until after the folder plates have been fully entered.

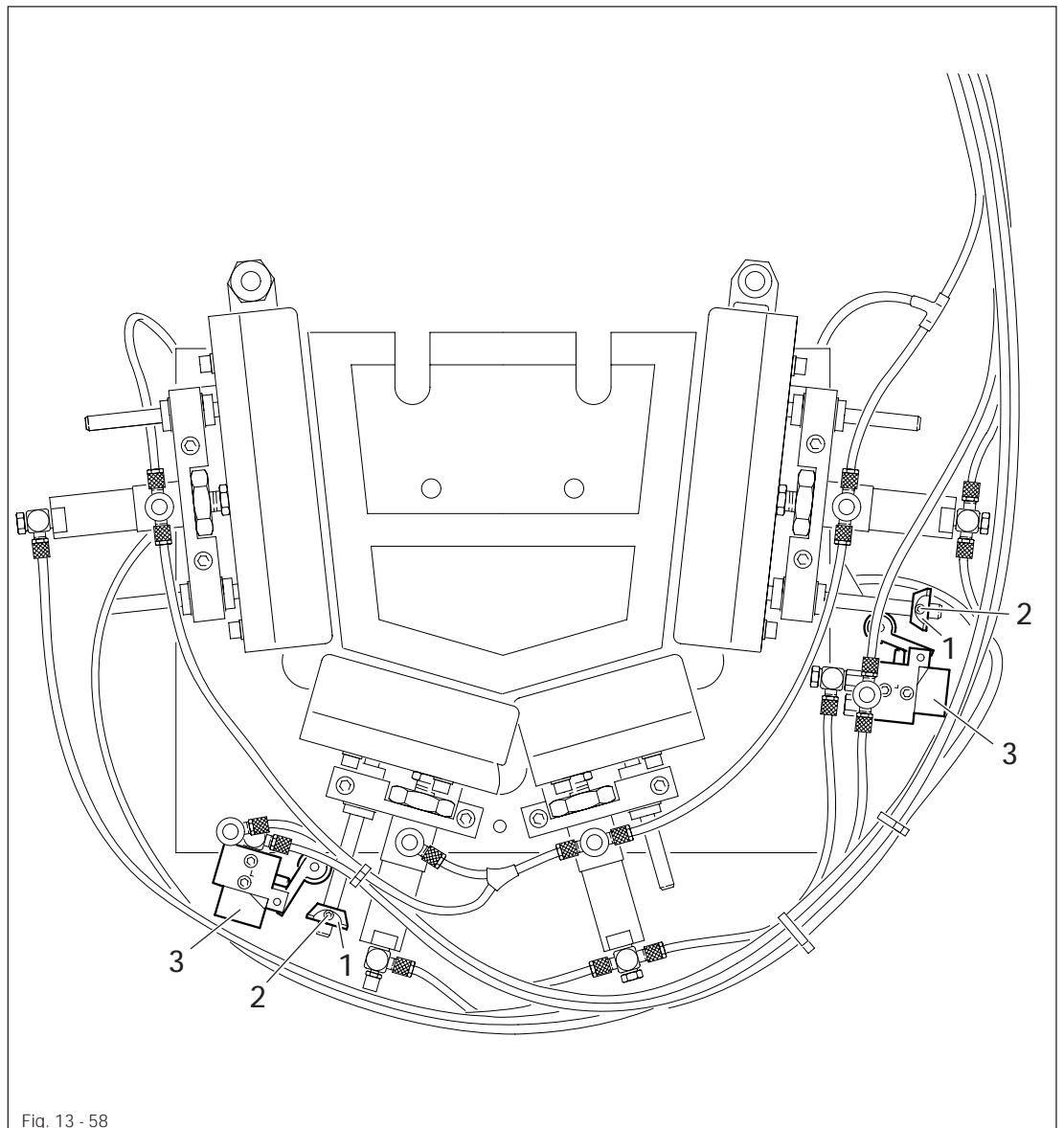
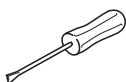

Fig. 13 - 58



- Move trip 1 (screws 2) according to the requirement.



The folder installation shown in Fig. 13-58 is for the third pocket style.

For other pocket styles, refer to the table found in chapter 13.08.16 **Actuating sequence of the folder plates** for the cylinders corresponding to the relevant switching positions.

The roller lever valves are on a cylinder of the second switching position, as well as on the cylinder of the final switching sequence.

## 13.08.20 Parallelism of seam to pocket

### Requirement

The seam must run parallel to the pocket edge.

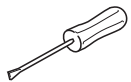
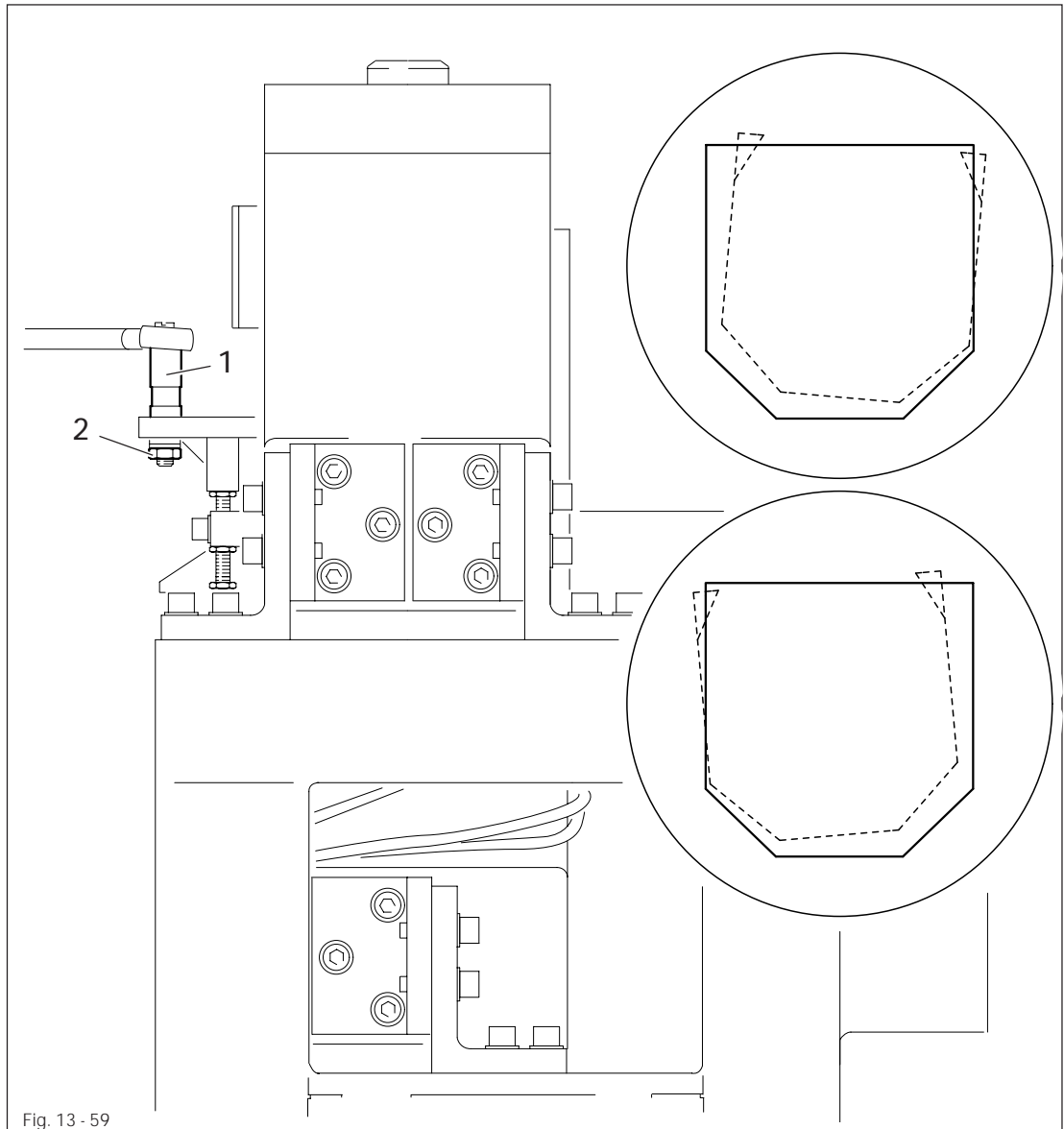

- Turn eccentric pin 1 (nut 2) according to the requirement.

## 13.08.21 Centering the pocket seam

### Requirement

The seam must be the same distance at the right and left to the pocket edge.

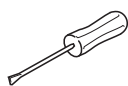
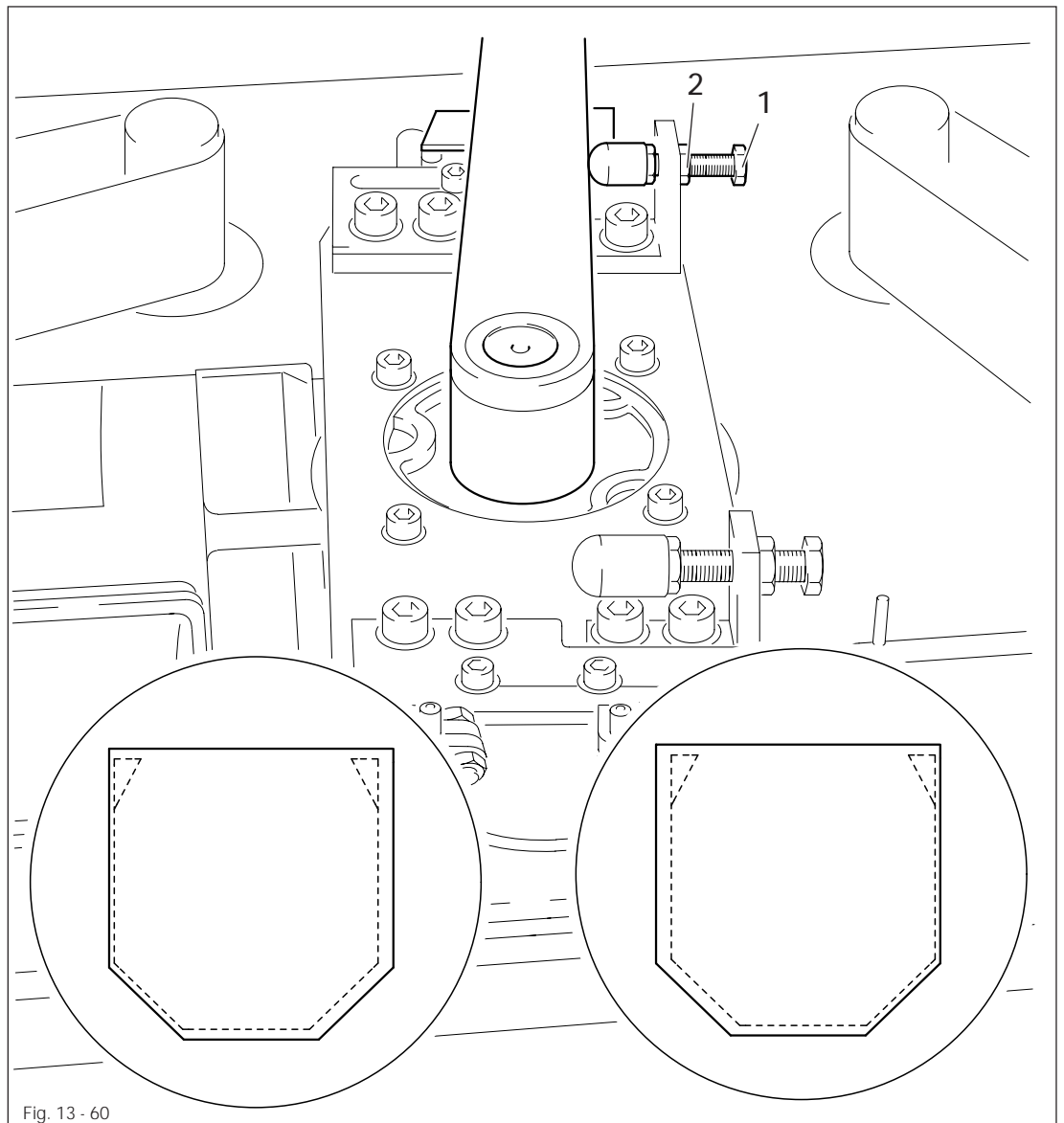

- Turn screw 1 (nut 2) according to the requirement.

# Adjustment

## 13.08.22 Distance of seam to pocket

### Requirement

The seam is to be at the same distance on all sides to the pocket edge.

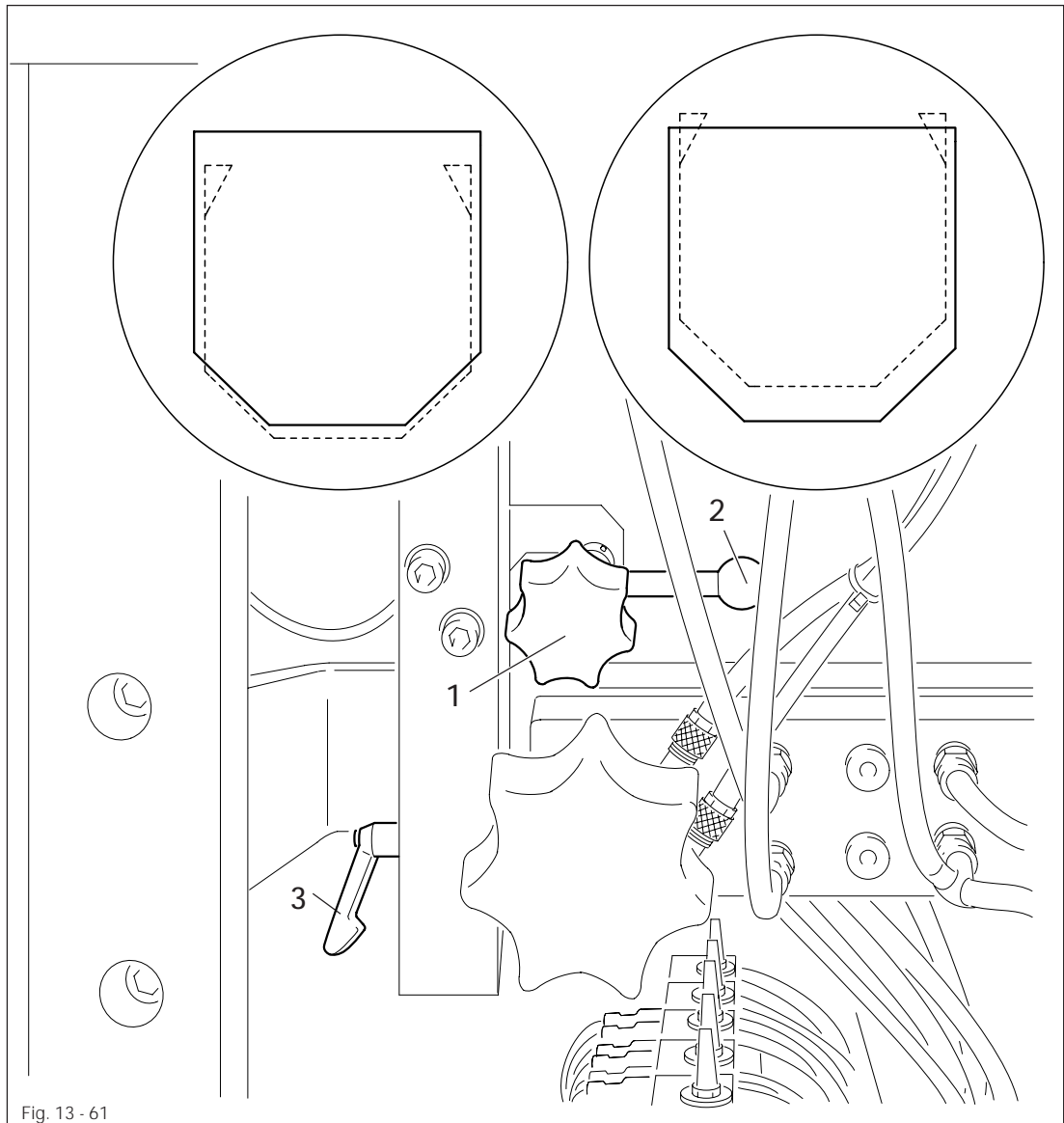
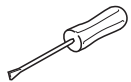

Fig. 13 - 61



- Turn adjusting screw 1 (toggle switch 2 and clamp lever 3) according to the **requirement**.

## 13.08.23 Seam backtack distance

### Requirement

The distance between the seam backtack and the pocket opening is to be approx. 1 mm.

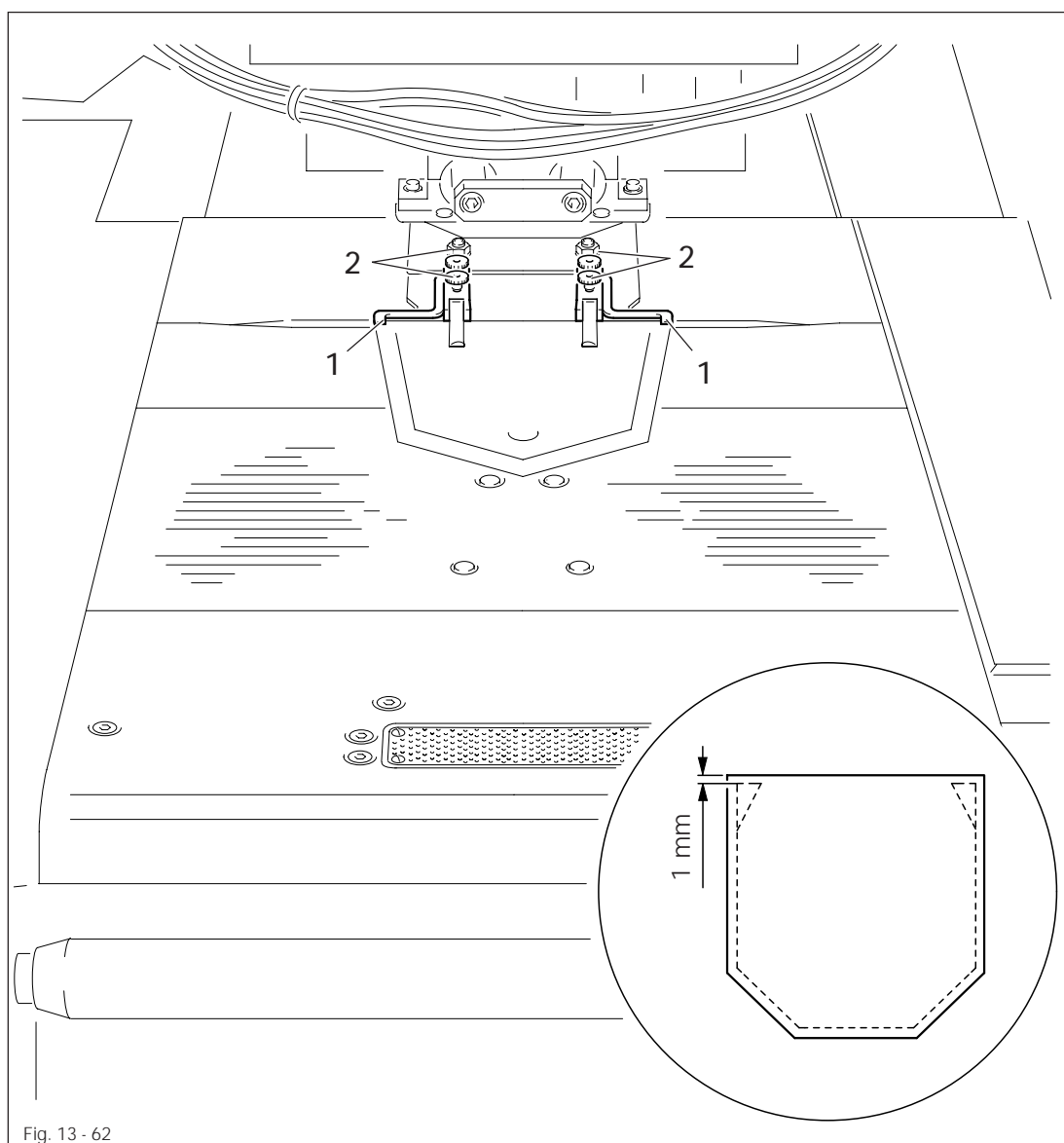
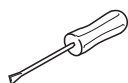

Fig. 13 - 62



- Adjust stops 1 (screws 2) on the pocket plate according to the requirement.

## 13.09 Shaping folder plates

### 13.09.01 New installation / self-manufacture of folder plates

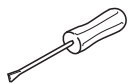
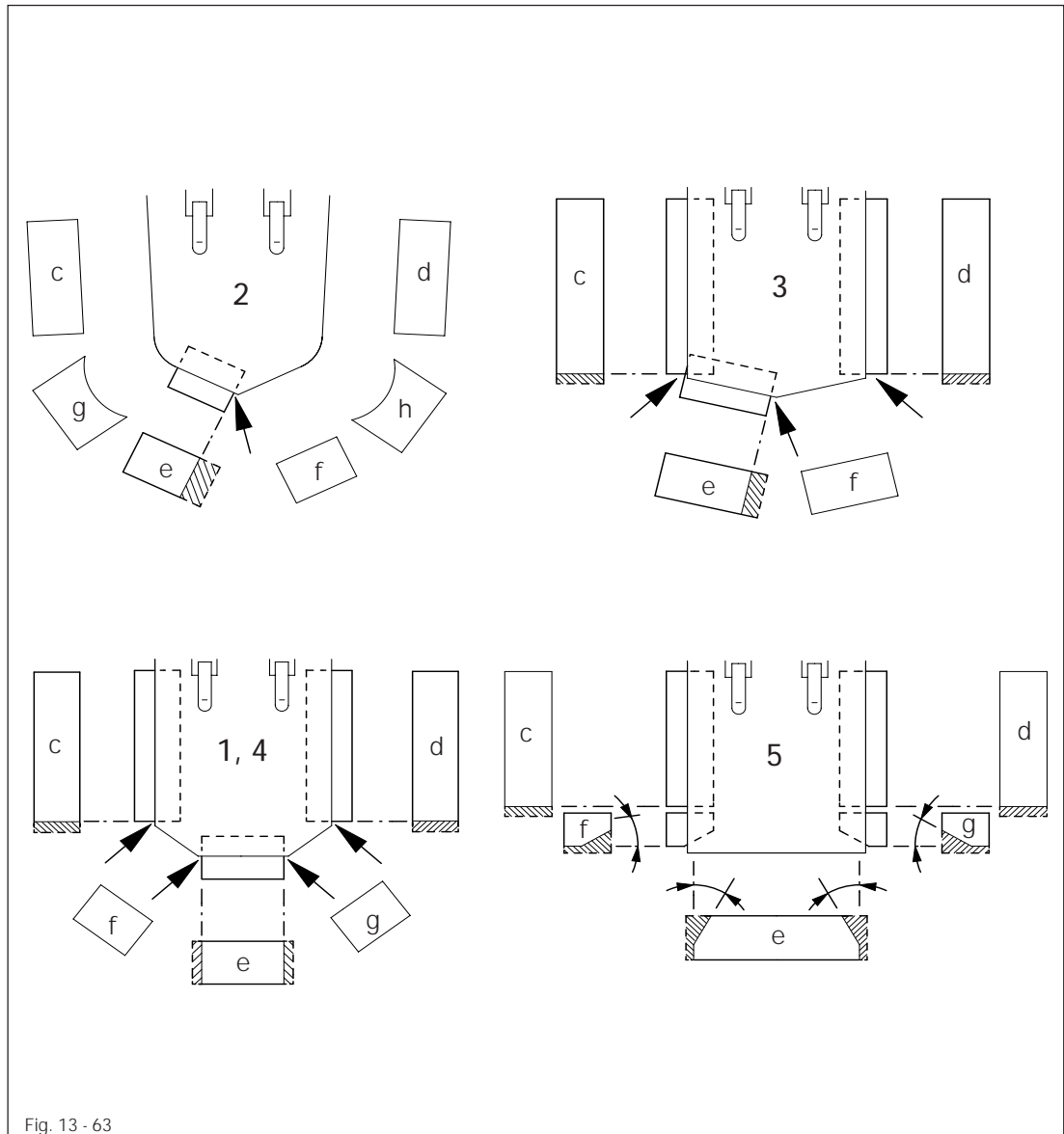

- Make and/or install the folder plates according to Fig. 13-63.



When newly installing or making the folder plates, make sure that they lie behind the corners of the pocket plate by at least the amount of the fabric thickness on the marked spots.



In the case of the fifth pocket style, the folder plates e, f and g must be additionally slanted by  $30^\circ$ .



## 13.09.02 Slanting the lateral folder plates



Do not begin with this work process until the adjustments in chapters 13.08.20 through 13.08.23 have been carried out.

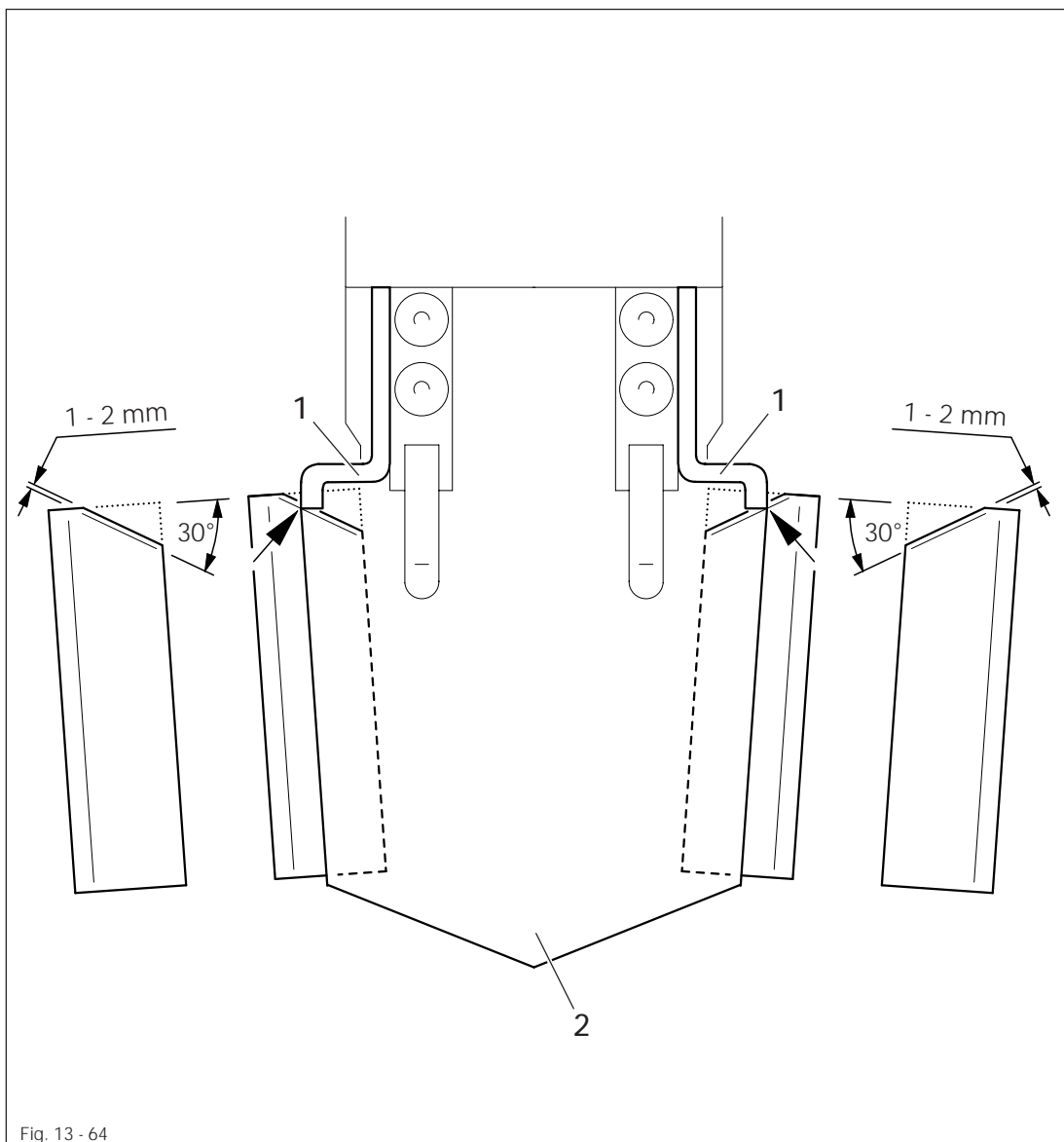
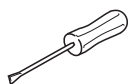

Fig. 13 - 64



- With the folder plates fully extended, transfer the front edges of the pocket stops 1 and the outer edge of the pocket plate 2 to the lateral folder plate.
- Trace slanted edge of  $30^\circ$ .
- Work the folder plate up to 1 - 2 mm before the trace.
- Round off the edges of the folder plate and polish.

# PFAFF

G.M. PFAFF  
Aktiengesellschaft

Postfach 3020  
D-67653 Kaiserslautern

Königstr. 154  
D-67655 Kaiserslautern

Telefon: (0631) 200-0  
Telefax: (0631) 172 02  
Telex: 45753 PFAFF D

Gedruckt in der BRD  
Printed in Germany  
Imprimé en R.F.A.  
Impreso en la R.F.A.  
Stampato in R.F.G.  
отпечатано ФРГ