

PFAFF

3306

Service Manual

Notes on safety

- The machine must only be used for the purpose intended and not without the safety devices it is equipped with; also, all relevant safety regulations must be adhered to.
- When gauge parts are exchanged (e.g. needle, presser foot, needle plate and feed dog), during threading, when the workplace is left, and during service work, the machine must be isolated from the mains by switching off the main switch or disconnecting the mains plug.
- On mechanically operated clutch motors without start inhibitor it is necessary to wait until the motor has stopped.
- Daily servicing work must only be carried out by appropriately trained persons.
- Repairs and special maintenance work must only be carried out by technicians or persons with appropriate training.
- For service or repair work on pneumatic systems the machine must be isolated from the compressed air supply system.
Exceptions to this are only adjustments and function checks made by appropriately trained technicians.
- Work on the electrical equipment must only be carried out by electrical engineers or appropriately trained persons.
- Work on parts and systems under electric current is not permitted, except as specified in regulations DIN 57 105 or VDE 0105.
- Conversions or changes to the machine must be authorized by us and only be made on adherence to all safety regulations.
- For repairs, only replacement parts approved by us must be used.

Service Manual Pfaff 3306 applies to the following machine versions:

3306, mechanical version
3306, with electro-pneumatic control (-966/..)
3306, with electro-magnetic control (-967/..)
3306, stem wrapping version (-9/..)
3306 for sewing on shank buttons (-15/..)

Tools, gauges and other items needed for adjustment

Set of screwdrivers with blades from 2 to 10 mm wide
Set of allen keys from 1.5 to 6.0 mm
Set of open-ended spanners from 7 to 14 mm
Open-ended spanner, 22 mm
Metal rule
C clamp No. 08-880137-00
Gauge No. 08-880136-01 (1.6; 1.8; 2.0; 2.2 and 2.4 mm)
Looper gauge No. 08-880138-01
Button gauge No. 08-880138-00
Two strips of white paper
Sewing thread and material

1 Preliminary adjustment of needle bar height

Correct setting:

With the stop-motion mechanism engaged (= needle bar at top dead centre) there must be a clearance of **31 mm** between needle point and needle plate.

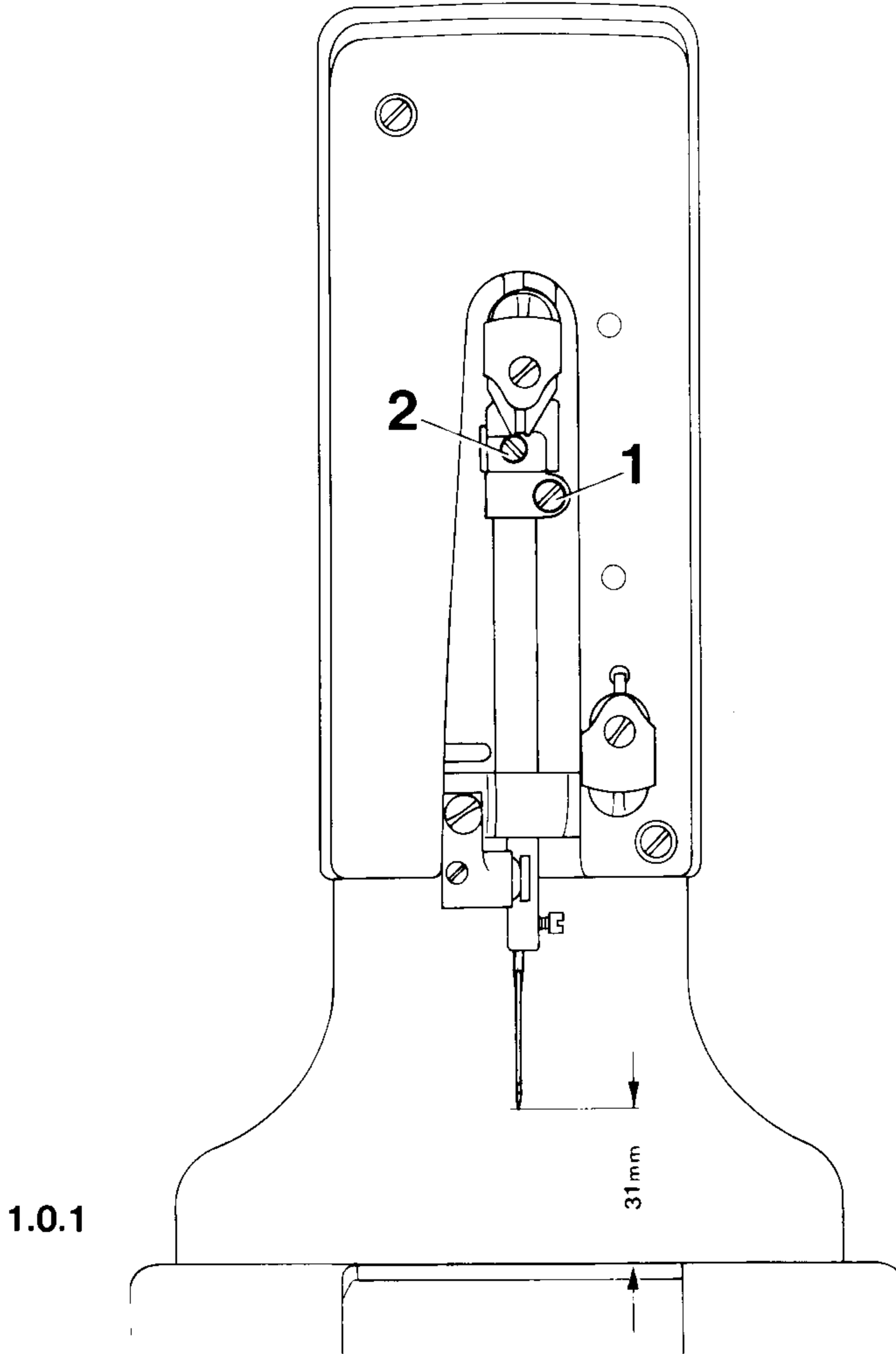

- 1.1 Engage stop-motion mechanism.
- 1.2 Loosen screws 1 and 2.
- 1.3 **Adjust the needle bar vertically, without turning it, so that a clearance of 31 mm is obtained between needle point and needle plate.**
- 1.4 In this position, tighten screw 1.
- 1.5 Leave screw 2 loose.

2

Preliminary adjustment of control cam

Correct setting:

The sideways movement of the needle must be equally divided before and after top dead center of the needle bar (it is advisable to carry out the check at the widest zigzag stitch setting).

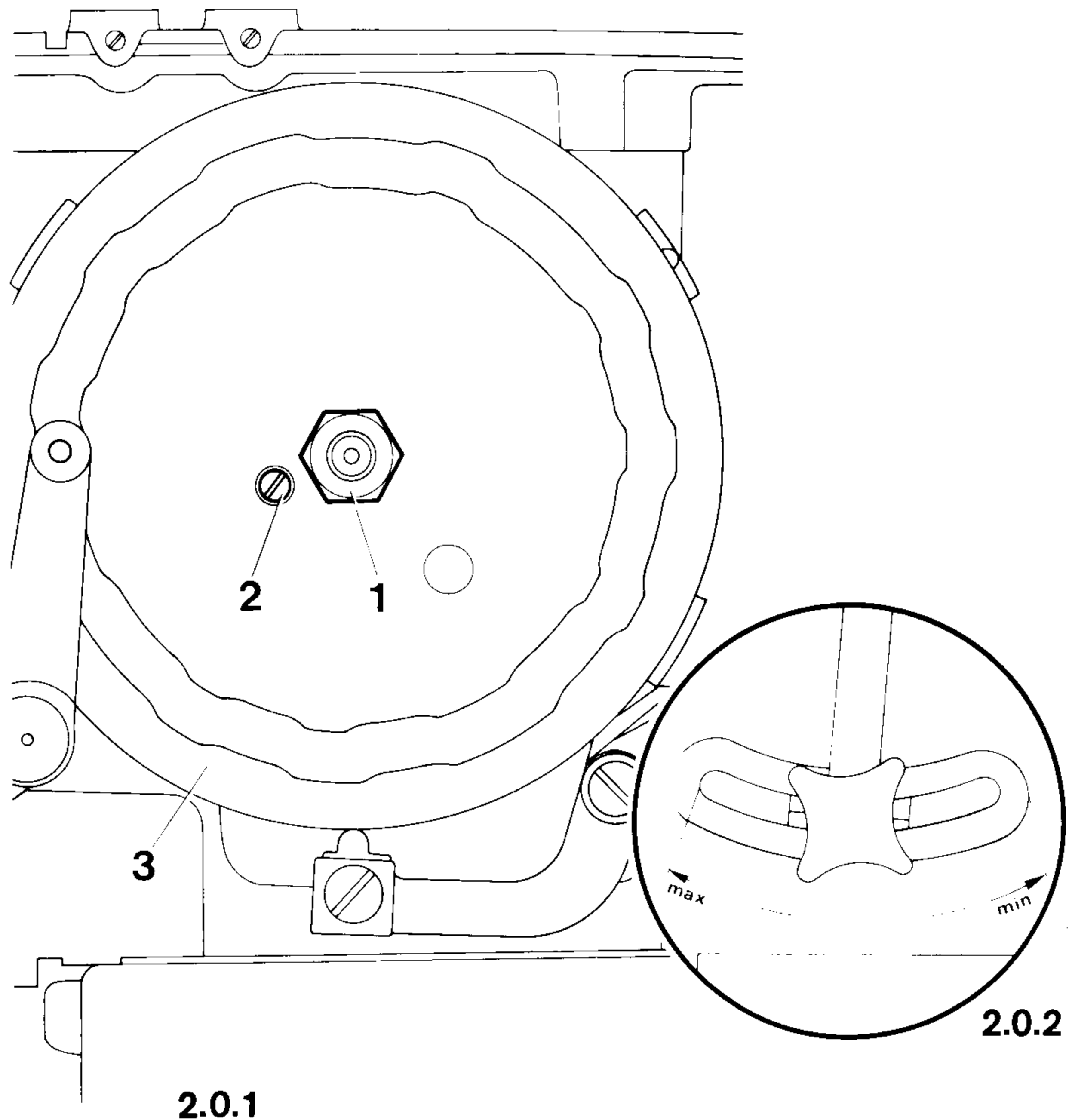

- 2.1 Set the widest zigzag stitch (see Fig. 2.0.2) and disengage the stop-motion mechanism.
- 2.2 Turn the belt pulley until the machine has made two to three stitches.
- 2.3 Loosen nut 1 and threaded stud 2.
- 2.4 Set the needle bar at top dead center.
- 2.5 **Turn control cam 3 until the needle bar frame has completed half of its sideways movement.**
- 2.6 Tighten threaded stud 2.
- 2.7 Check this adjustment (see "Correct setting").
- 2.8 Tighten nut 1.

3 Centering the needle throw in the needle slot

Correct setting:

With the machine set at its widest stitch, the needle must pass the right and left ends of the needle slot at the same distance (Fig. 3.0.2).

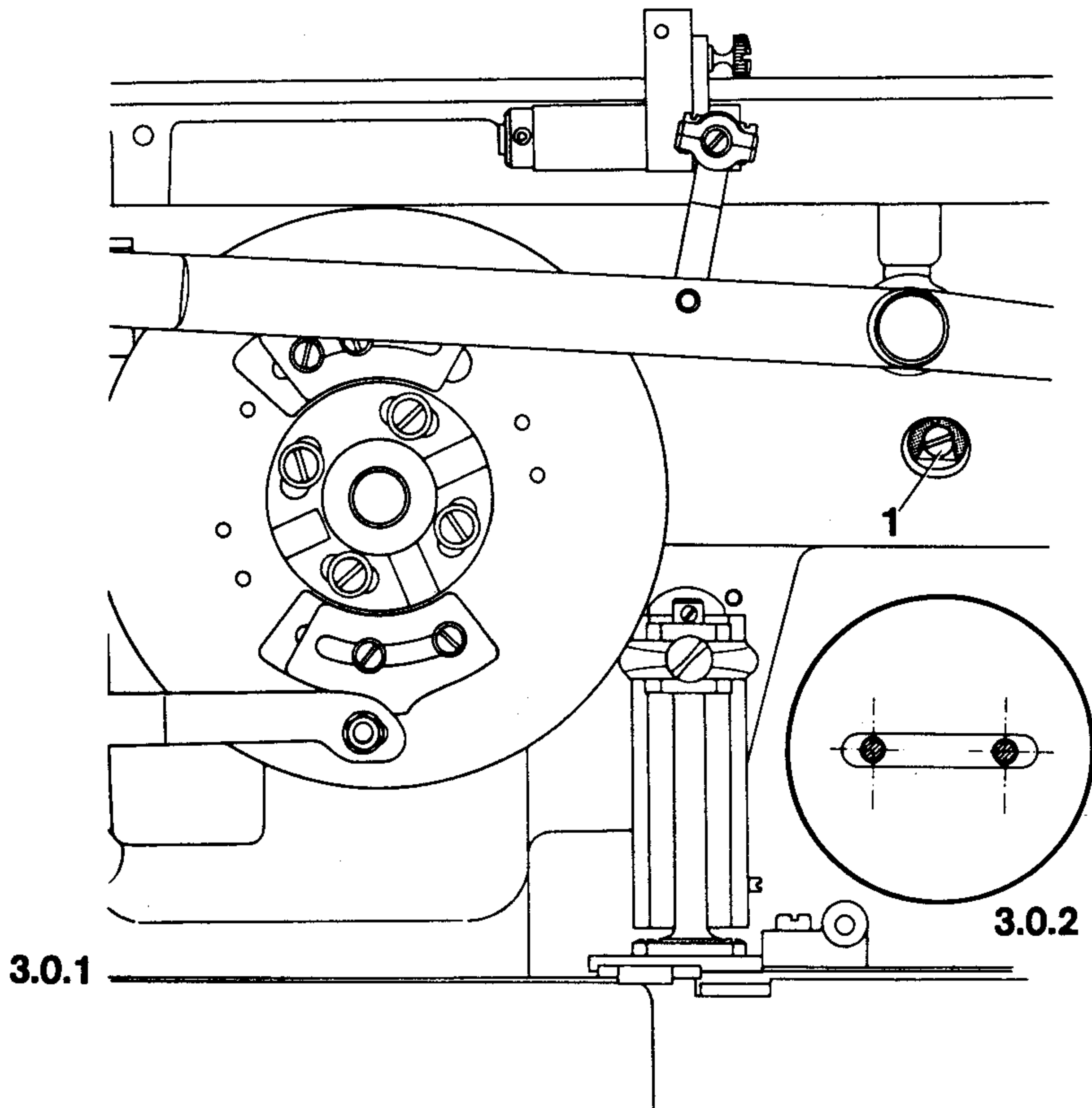

- 3.1 Set the widest zigzag stitch (see Fig. 2.0.2) and disengage the stop-motion mechanism.
- 3.2 Loosen screw 1.
- 3.3 **Position the needle bar frame so that the needle enters the needle slot at the same distance from each end when the balance wheel is turned (see Fig. 3.0.2).**
- 3.4 Tighten screw 1.
- 3.5 Check this adjustment (see "Correct setting").

4 Centering the smallest needle throw within the largest needle throw

Correct setting:

The smallest needle throw must be centered exactly within the largest needle throw (Fig. 4.0.2)

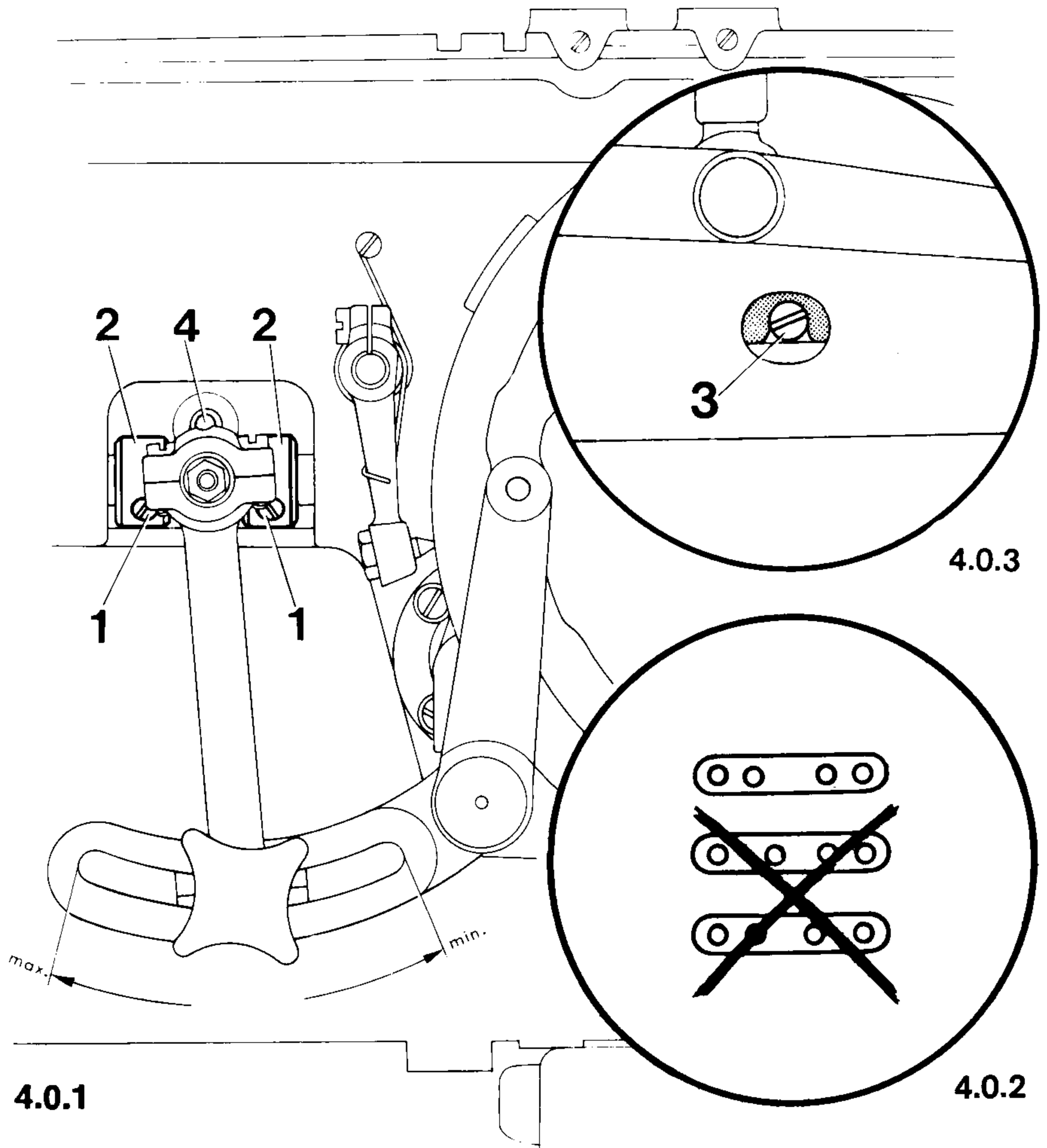

- 4.1 Set the widest zigzag stitch (Fig. 4.0.1) and disengage the stop-motion mechanism.
- 4.2 Turn the belt pulley in its normal direction until the machine has made two or three stitches.
- 4.3 Place a piece of white paper over the needle plate and hold it there.

- 4.4 Turn the belt pulley in its normal direction until the needle just pricks the paper.
- 4.5 Then turn the belt pulley in the opposite direction until the needle just pricks the paper again.
- 4.6 Raise the needle a little again, holding the paper fast.
- 4.7 Set the smallest needle throw (narrowest zigzag stitch), as shown in Fig. 4.0.1.
- 4.8 Turn the belt pulley opposite to its normal direction until the needle pricks the paper.
- 4.9 Turn the belt pulley in its normal direction until the needle pricks the paper again.
- 4.10 If the smallest needle throw is not centered within the largest needle throw, proceed as follows:
 - 4.10.1 Loosen screws **1**.
 - 4.10.2 Loosen screw **3**, which is accessible through the opening at the back of the machine (Fig. 4.0.3), and move crank **4** a little to the right or left.
 - 4.10.3 Tighten screw **3** and check this adjustment (see "Correct setting").
 - 4.10.4 Push collars **2** up against crank **4** and tighten screws **1** securely.
- 4.11 Again check the setting specified in Section 3.

5

Adjusting the lengthwise movement of the control bar

Correct setting:

With the control bar set to make its longest lengthwise movement, the front and rear edges of the feed plate cutout must be the same distance from the needle slot at either end of the control bar stroke (see Fig. 5.0.2).

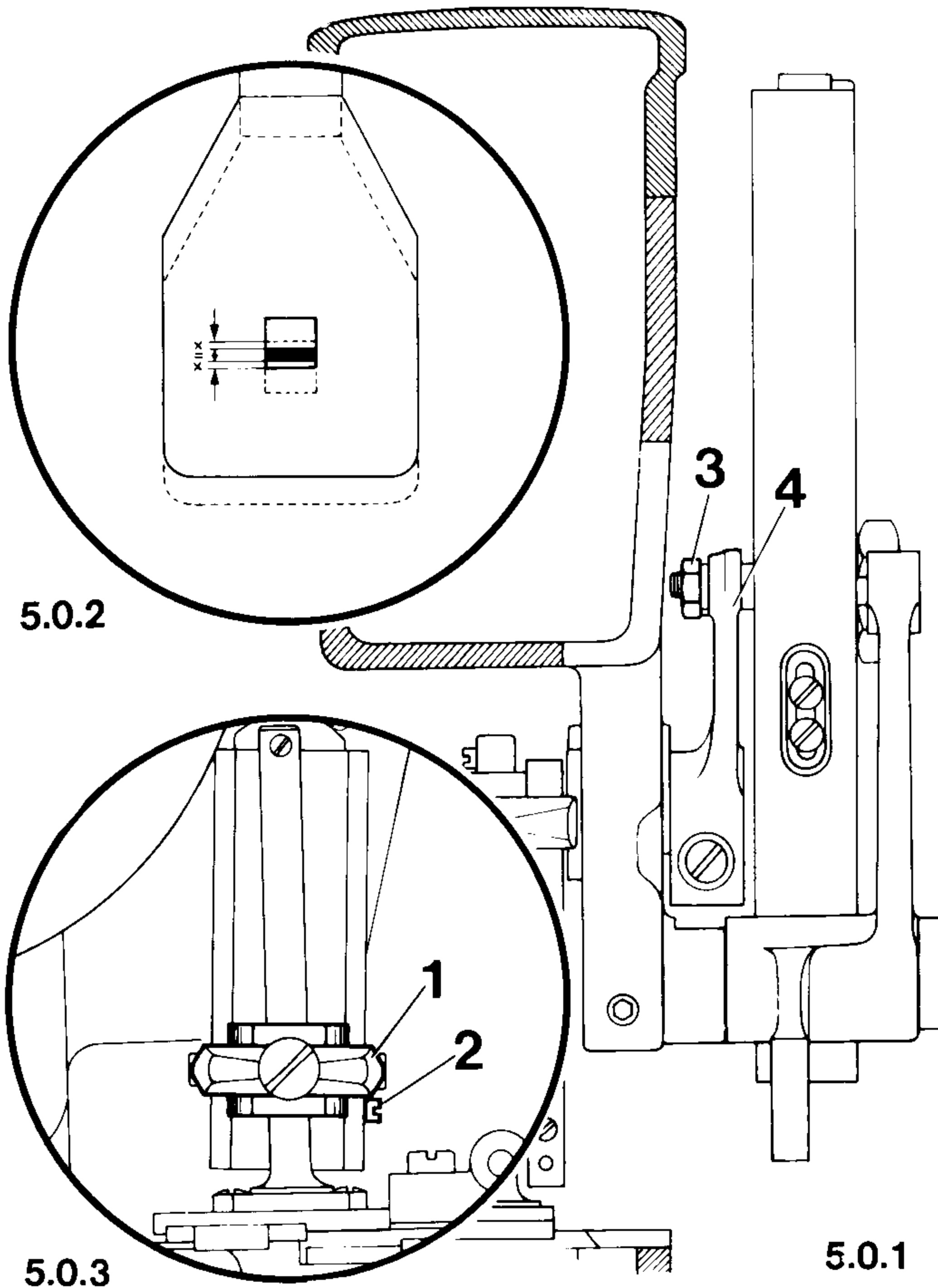

Note:

The roller of lever 4 must be level with the worm gear shaft. If required, loosen the retaining screws and insert the eccentric bearing of lever 4 turned through 180°.

- 5.1 Push retaining clamp 1 up against screw 2 and disengage the stop-motion mechanism.
- 5.2 Turn the belt pulley in its normal direction and simultaneously check the lengthwise motion of the control bar.
- 5.3 If the setting is not as specified above, proceed as follows:
 - 5.3.1 Loosen nut 3 and reposition lever 4 a little.
 - 5.3.2 Tighten nut 3.
 - 5.3.3 Check this adjustment (see "Correct setting").
- 5.4 Repeat the above adjustment until the setting is as described in "Correct setting".

6

Driving belt inside the machine

Correct setting:

The belt tension must be adjusted so that the machine does not bind and there is no play in the gears.

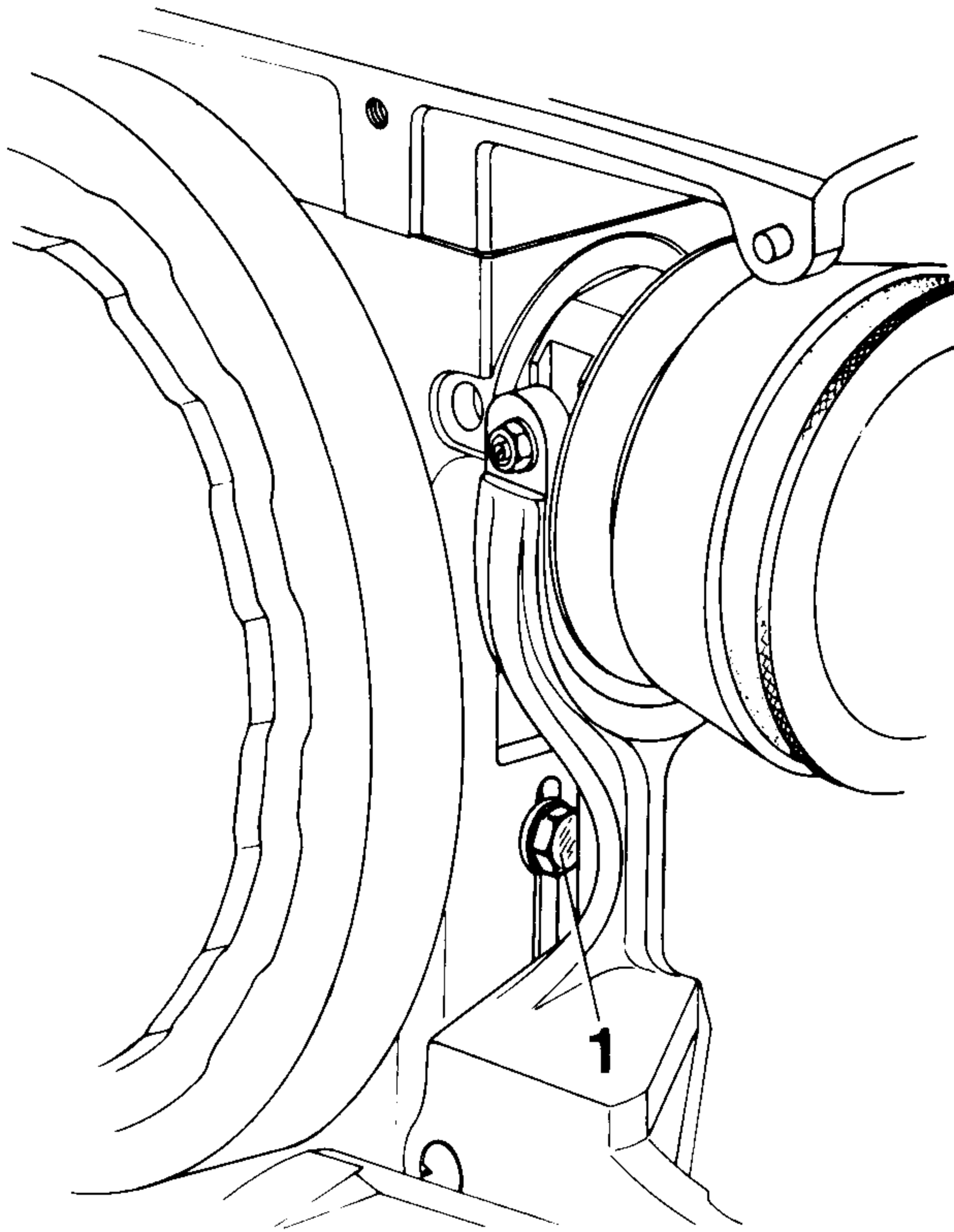

6.0.1

- 6.1 Loosen screw 1.
- 6.2 **Move screw 1 to adjust the tension of the driving belt so that the machine does neither bind nor have noticeable play in its gears.**
- 6.3 Tighten screw 1.
- 6.4 Check this adjustment (see "Correct setting").

7 Drag link assembly

Correct setting:

With the stop mechanism in its locked position, the slot of shaft 4 must be in line with slot 5 in the housing. Also, the milled-out section of shaft 4 (see arrow in Fig. 7.0.2) must be positioned at the top side.

Note:

Make sure that driving crank 3 pulls drag link 6 when the belt pulley is turned.

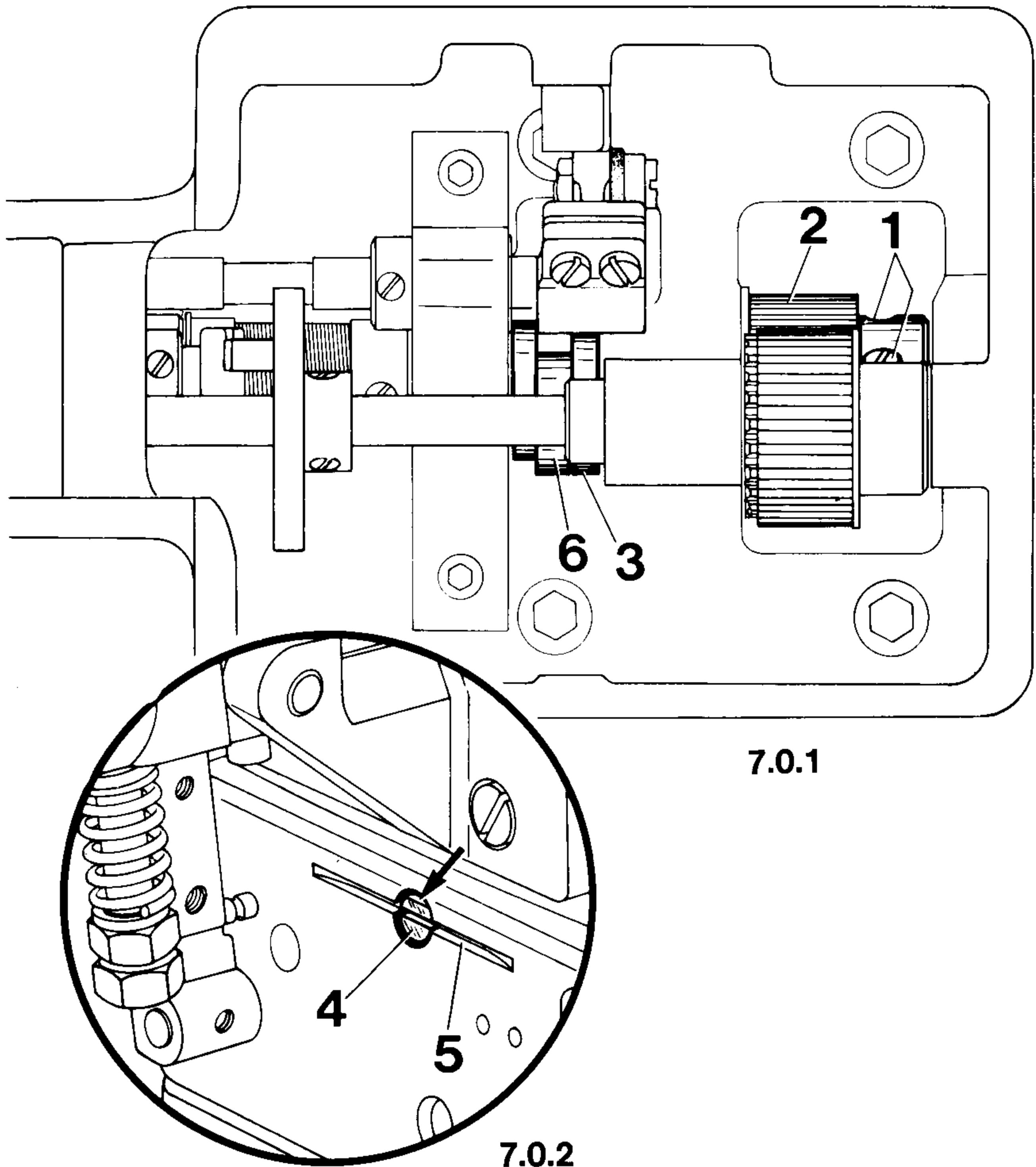

- 7.1 Disengage the stop mechanism and turn the belt pulley in its normal direction until the first screw 1 is accessible (as seen in the direction of rotation).
- 7.2 Loosen screw 1 of gear 2.
- 7.3 Engage the stop mechanism and loosen the second screw 1, too.

- 7.4 **Turn crank 3 so that the slot of shaft 4 is in line with slot 5 in the housing and the milled-out section (see arrow in Fig. 7.0.2) is at the top.**
- 7.5 Block the machine in this position by inserting the 2.4 mm blade of the needle rise gauge in the slot of shaft 4.
- 7.6 Tighten the accessible screw 1.
- 7.7 Remove the needle rise gauge and disengage the stop mechanism.
- 7.8 Turn the belt pulley until the second screw 1 is accessible.
- 7.9 Tighten screw 1.
- 7.10 Check this adjustment (see "Correct setting").

8 Positioning the looper shaft in relation to the needle

Correct setting:

The needle point must contact the gauge pin in the looper shaft when the needle descends on the far right and far left of its throw (Fig. 8.0.2).

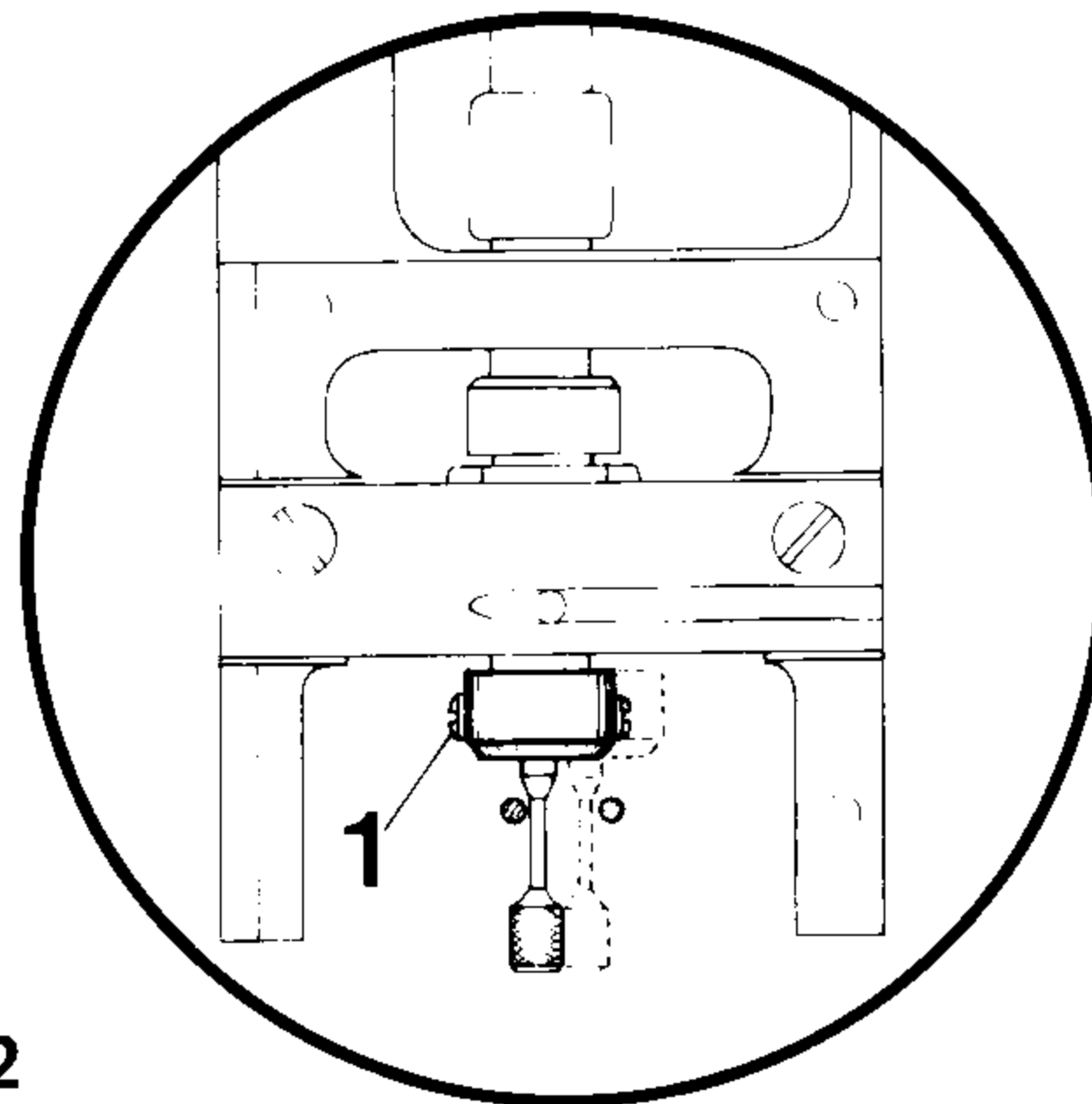
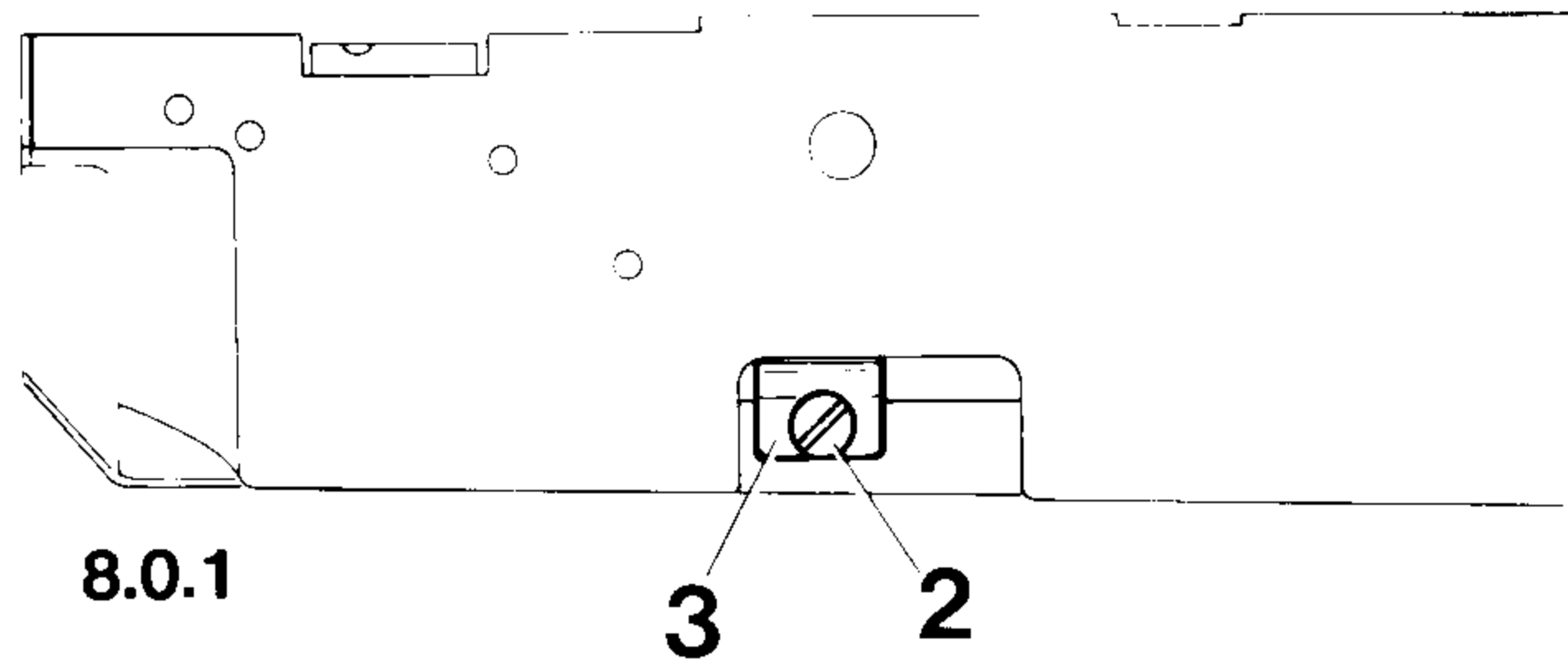

- 8.1 Remove button clamp, feed plate and needle plate.
- 8.2 Set the widest zigzag stitch and disengage the stop-motion mechanism.
- 8.3 Turn the belt pulley in its normal direction until looper retaining screw 1 (first screw as seen in direction of rotation) is accessible.
- 8.4 Loosen screw 1 and remove the looper.
- 8.5 Push the gauge pin fully into the looper shaft.
- 8.6 Loosen screw 2.
- 8.7 **Turn crank 3 so that the needle point contacts the gauge pin when the needle descends on the far right and far left of its throw (Fig. 8.0.2).**
- 8.8 Tighten screw 2.
- 8.9 Check this adjustment (see "Correct setting").
- 8.10 Remove the gauge pin.

9

Basic setting of thread trimming knife

(This adjustment does not apply to subclass -9/..)

Correct setting:

The front edge of knife **1** and front edge of looper **2** must be flush (see arrow in Fig. 9.0.1). The distance between bottom edge of knife **1** and top edge of the looper must be approx. **2.5 mm** (see Fig. 9.0.2).

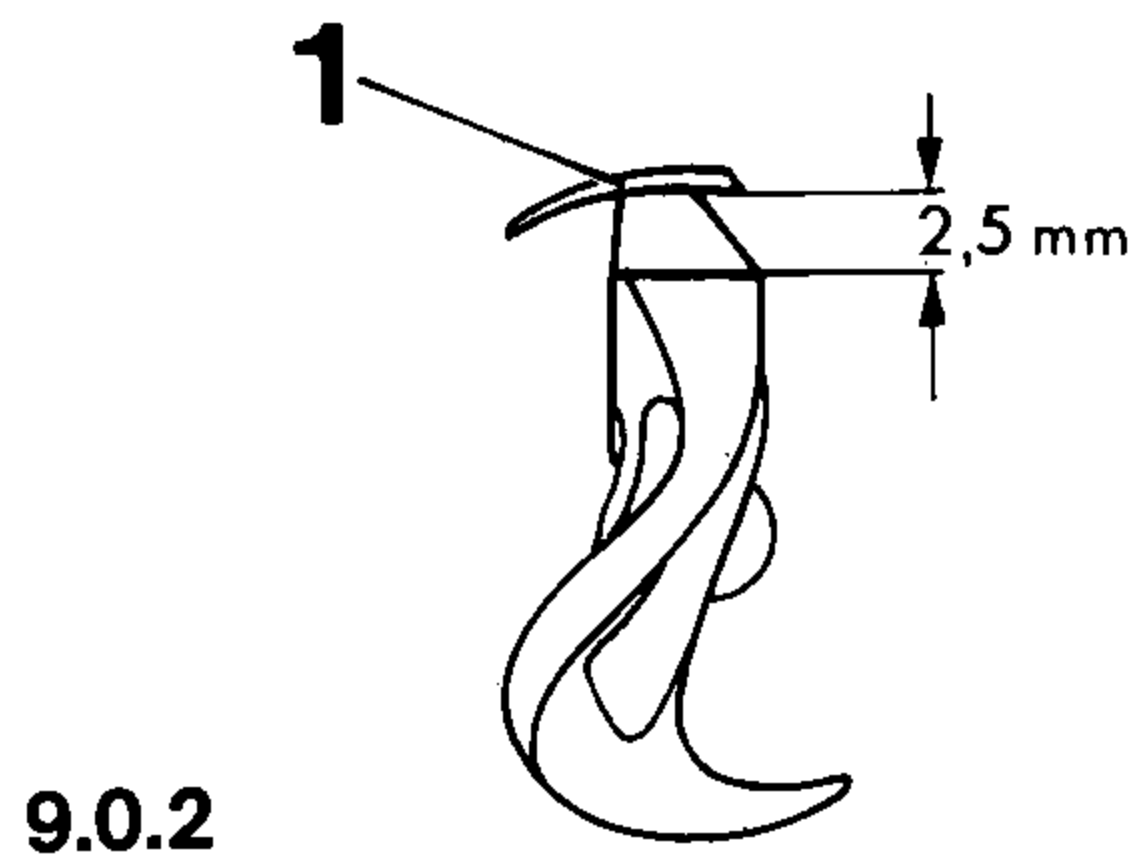
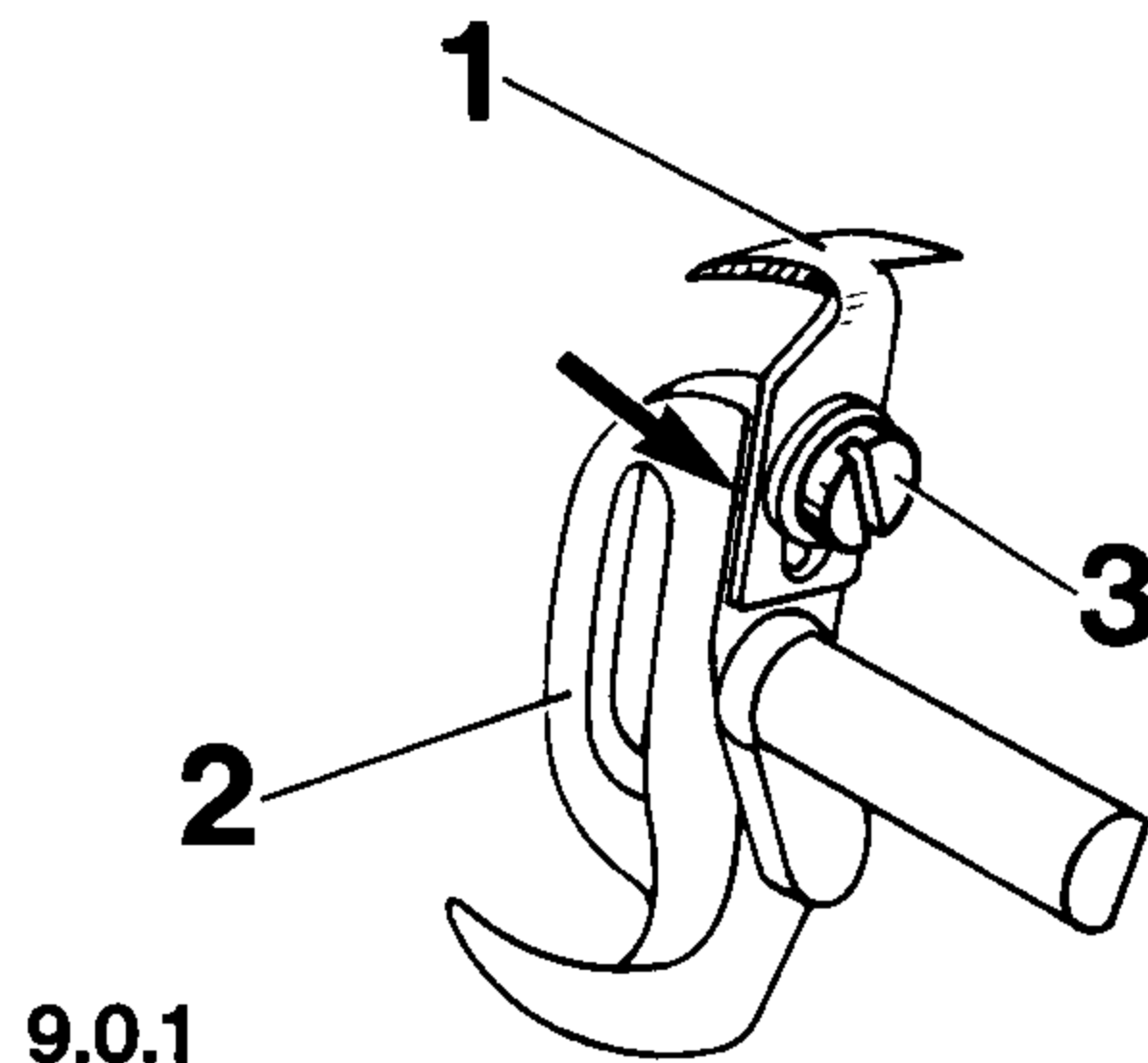

9.1 **Loosen screw 3 on the removed looper and position the knife accordingly.**

9.2 In this position, tighten screw **3**.

Note: Depending on the type and size of thread used it may be necessary to deviate from this basic setting.

10

Timing the looper and setting the looper-to-needle clearance

Correct setting:

With the machine set at the widest stitch, the looper point must be at the center line of the needle when the latter has risen approx. **2.4 mm** from bottom dead center on the right of its throw. In this position, there must be a clearance of approx. **0.1 mm** between looper point and needle.

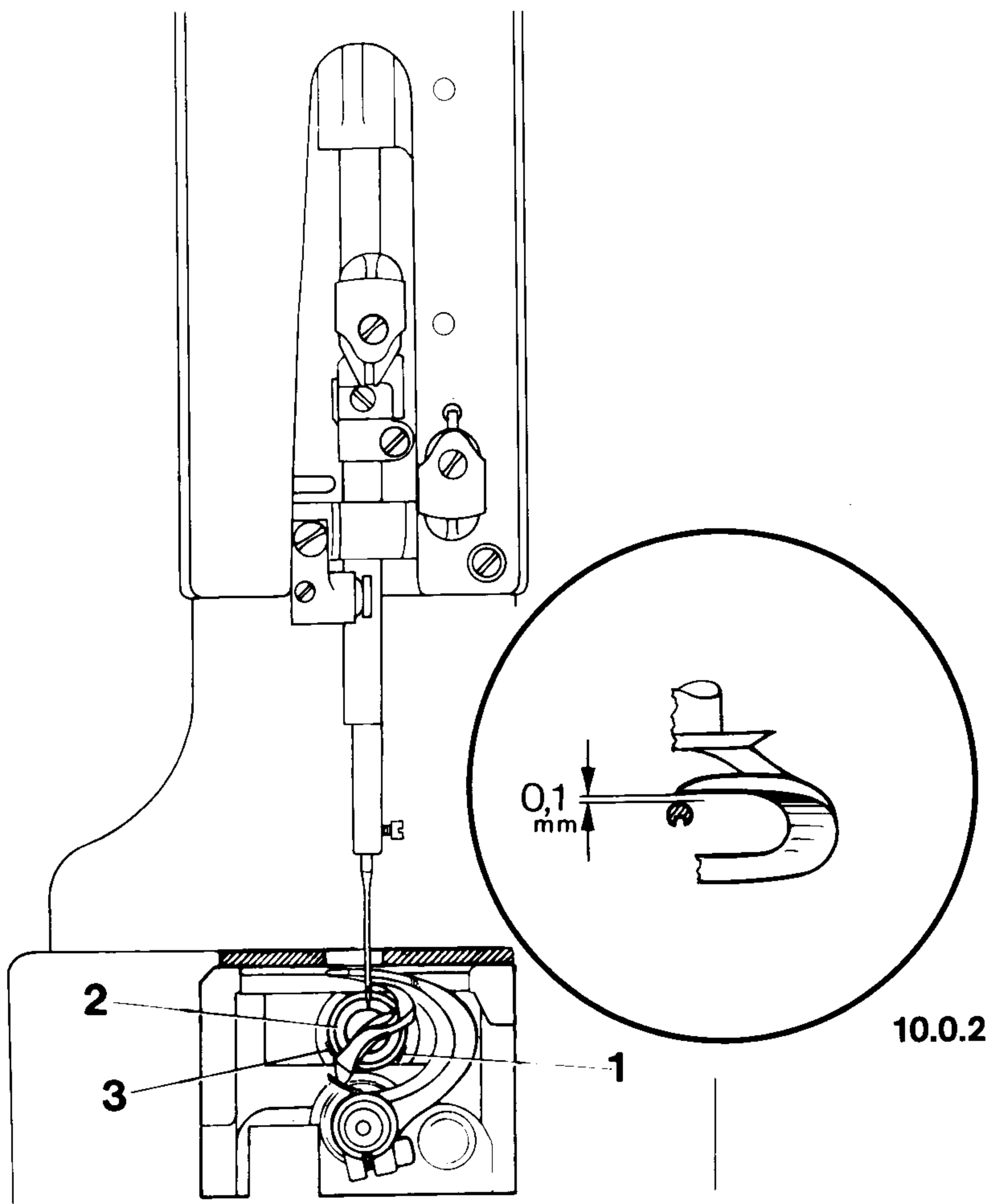

10.0.1

10.1

Set the widest stitch and disengage the stop-motion mechanism.

10.2

Insert the looper so that screw 1 (first screw in direction of rotation) of collar 2 is positioned over the flat on the looper shaft.

10.3

Tighten screw 1 a little.

10.4

Turn the belt pulley in its normal direction until the needle bar is positioned at bottom dead center on the right of its throw.

- 10.5 Place the needle rise gauge (**2.4 mm**) against the needle bar bushing and secure it in position with the C clamp.
- 10.6 Remove the needle rise gauge and turn the belt pulley in its normal direction until the C clamp contacts the needle bar bushing.
- 10.7 Loosen screw **3**.
- 10.8 **Turn collar 2 until the looper point is at the center line of the needle and adjust the looper so that there is a clearance of 0.1 mm between looper point and needle (Fig. 10.0.2).**
- 10.9 Tighten screws **1** and **3**.
- 10.10 Check this adjustment (see "Correct setting").
- 10.11 Remove the C clamp from the needle bar.

11

Checking the drag link

Correct setting:

With the needle bar at bottom dead center, the looper must be roughly in the position shown in Fig. 11.0.1.
With the needle bar at top dead center, the looper must be positioned as shown in Fig. 11.0.2.

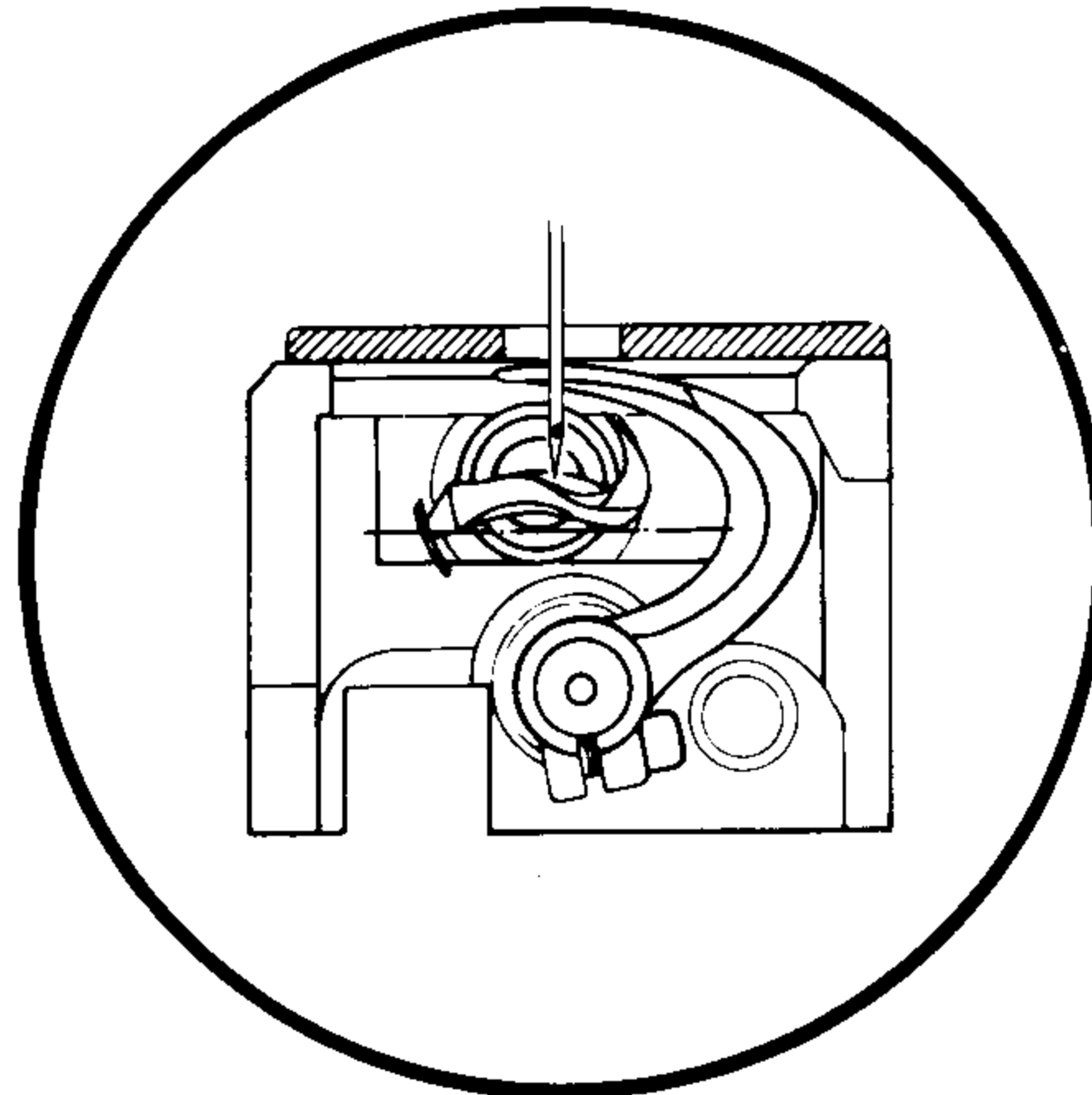

11.0.1

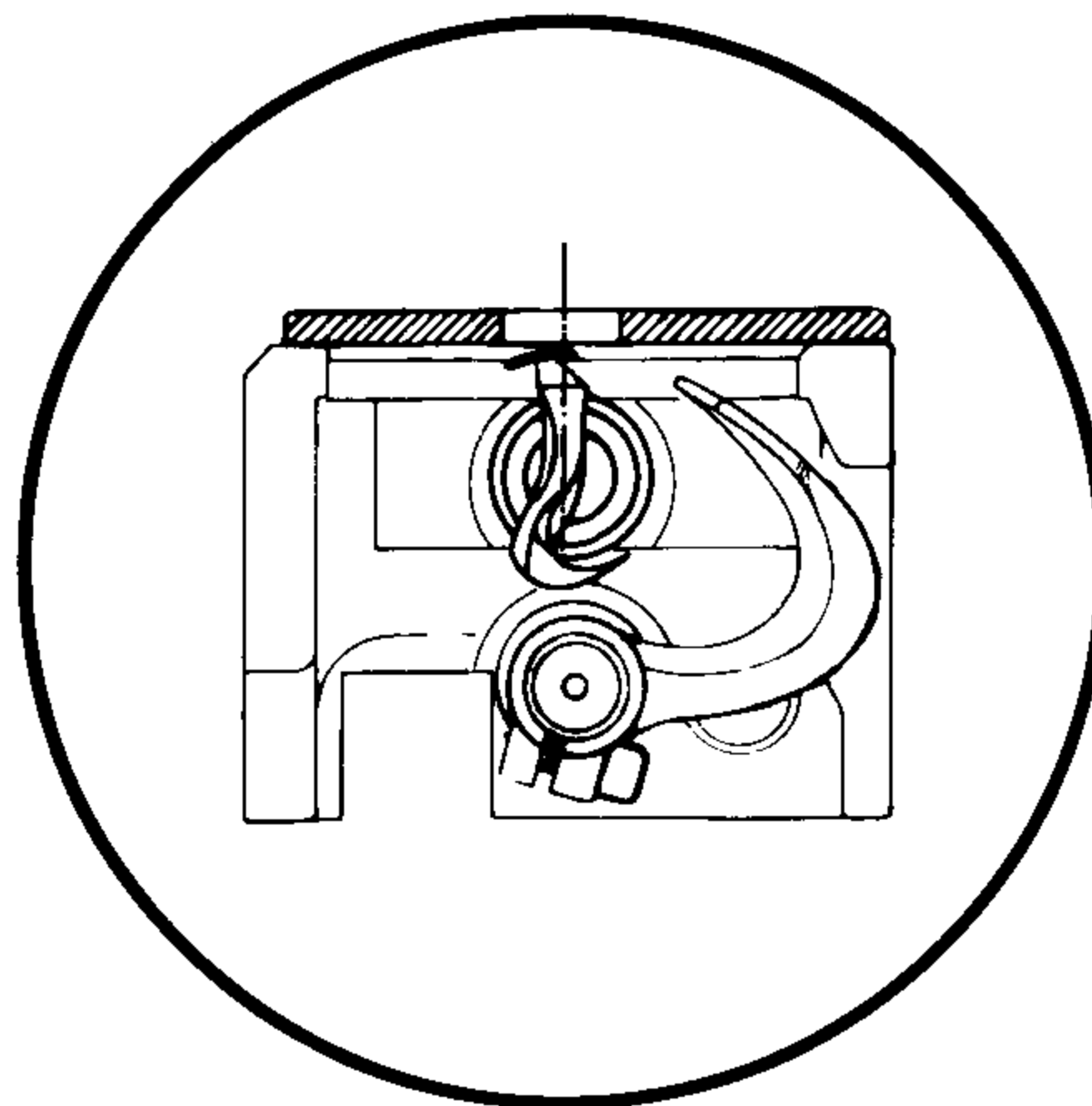

11.0.2

11.1 Check the two looper positions.

11.2 If they are incorrect, check the settings specified in Sections 7 and 10 again.

Correct setting:

With the machine set at the widest stitch, the bottom edge of the looper point must be approx. **0.5 mm** above the top edge of the needle eye when the looper point is at the center-line of the needle as it ascends on the left of its throw (Fig. 12.0.2).

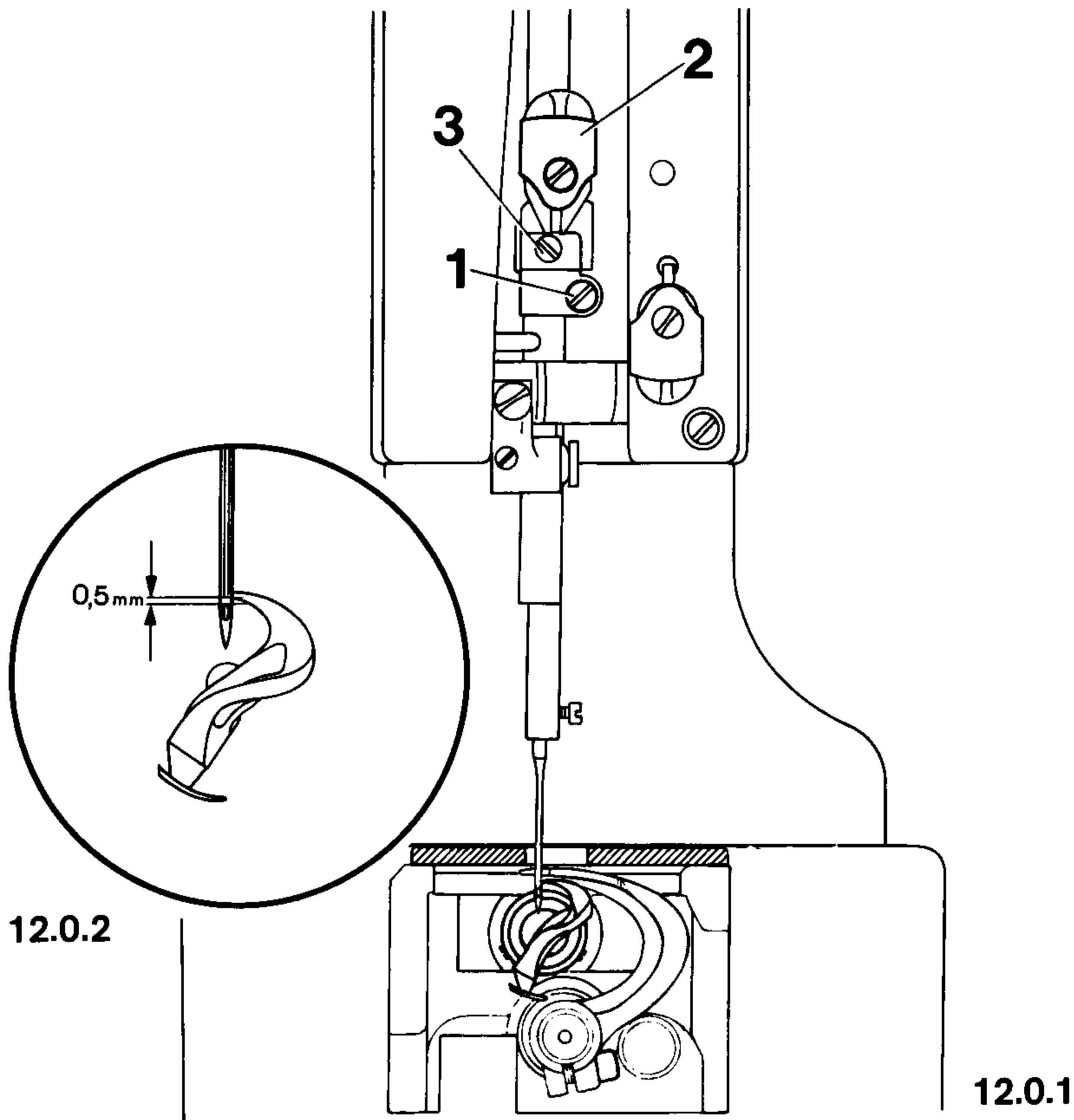

- 12.1 Set the widest zigzag stitch and disengage the stop-motion mechanism.
- 12.2 Turn the belt pulley until the needle bar is at bottom dead center on the left of its throw.
- 12.3 Continue turning the belt pulley until the looper point is exactly at the center line of the needle.
- 12.4 **Loosen clamp screw 1 and adjust the height of the needle bar so that the bottom edge of the looper point is approx. 0.5 mm above the top of the needle eye (Fig. 12.0.2).**
- 12.5 In this position, tighten clamp screw 1, making sure the needle bar has not been turned.
- 12.6 Check this adjustment (see "Correct setting").
- 12.7 Push thread take-up 2 against the needle bar lug and position it in the middle of the face plate cutout.
- 12.8 In this position, tighten screw 3 securely.

13 Blind looper

13.1 Timing

Correct setting:

When the point of the descending needle is level with the bottom edge of blind looper 3 the latter must be at its left point of reversal (Fig. 13.0.2).

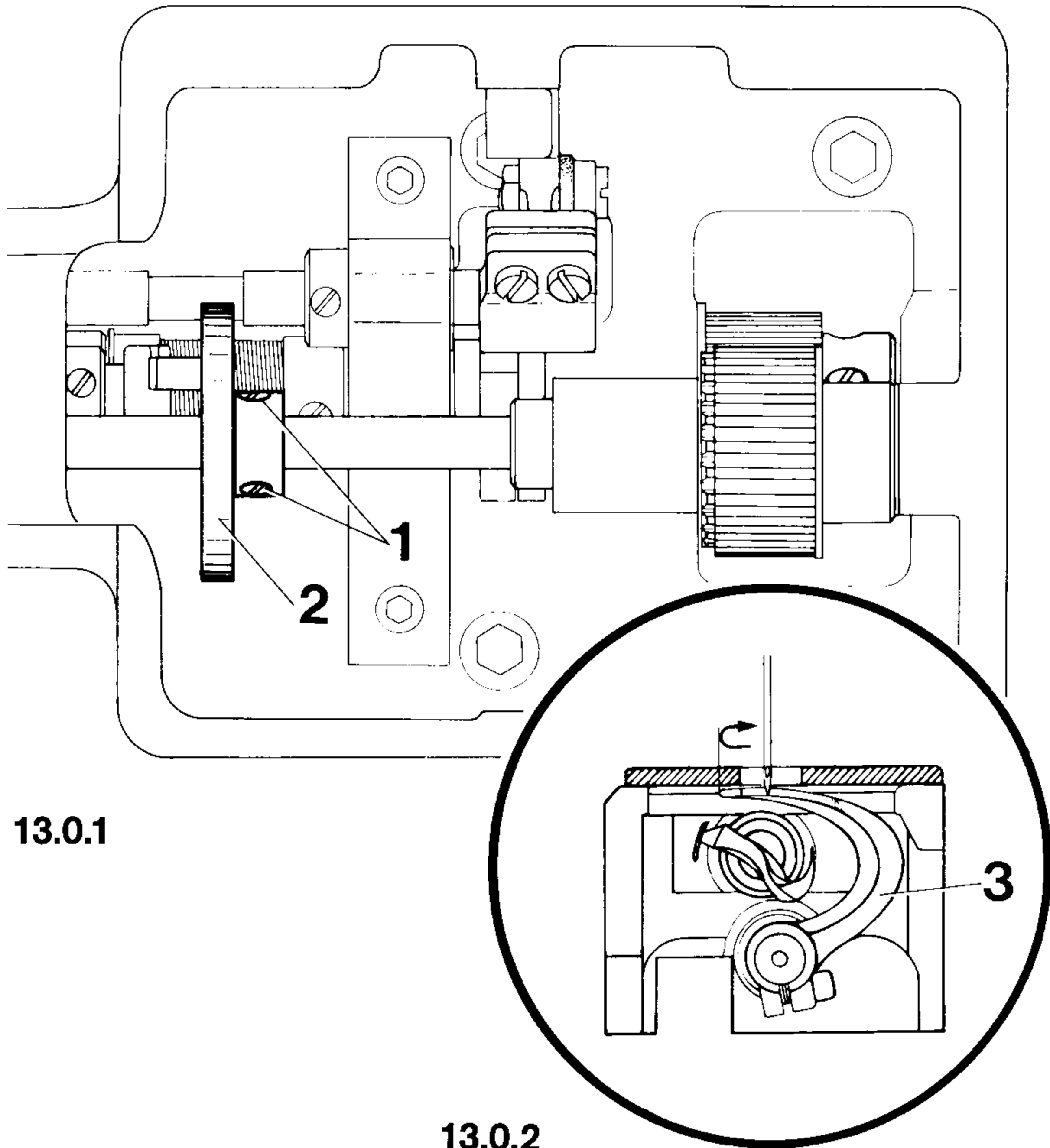

13.0.1

13.0.2

- 13.1.1 Loosen screws **1** and re-tighten them just enough to allow control cam **2** to be turned against resistance.
- 13.1.2 Disengage the stop-motion mechanism and turn the belt pulley in its normal direction so that the point of the descending needle is level with the bottom edge of the blind looper.
- 13.1.3 **Turn control cam 2 until blind looper 3 is at its left point of reversal (Fig. 13.0.2).**
- 13.1.4 In this position, tighten the accessible screw **1**, making sure that the roller does not foul the bottom of the track in control cam **2**.
- 13.1.5 Check this adjustment (see "Correct setting").
- 13.1.6 Also tighten the second screw **1**.

13.2 Radial and axial setting

Correct setting:

With the machine set at the widest stitch, there must be a clearance of approx. **0.5 mm** between thread puller hook **2** and the needle when the point of the needle ascending on the left of its throw is level with the bottom edge of the blind looper (Fig. 13.0.4). There must be a clearance of approx. **0.8 mm** between the rear edge of the needle slot and the front edge of the blind looper (Fig. 13.0.4).

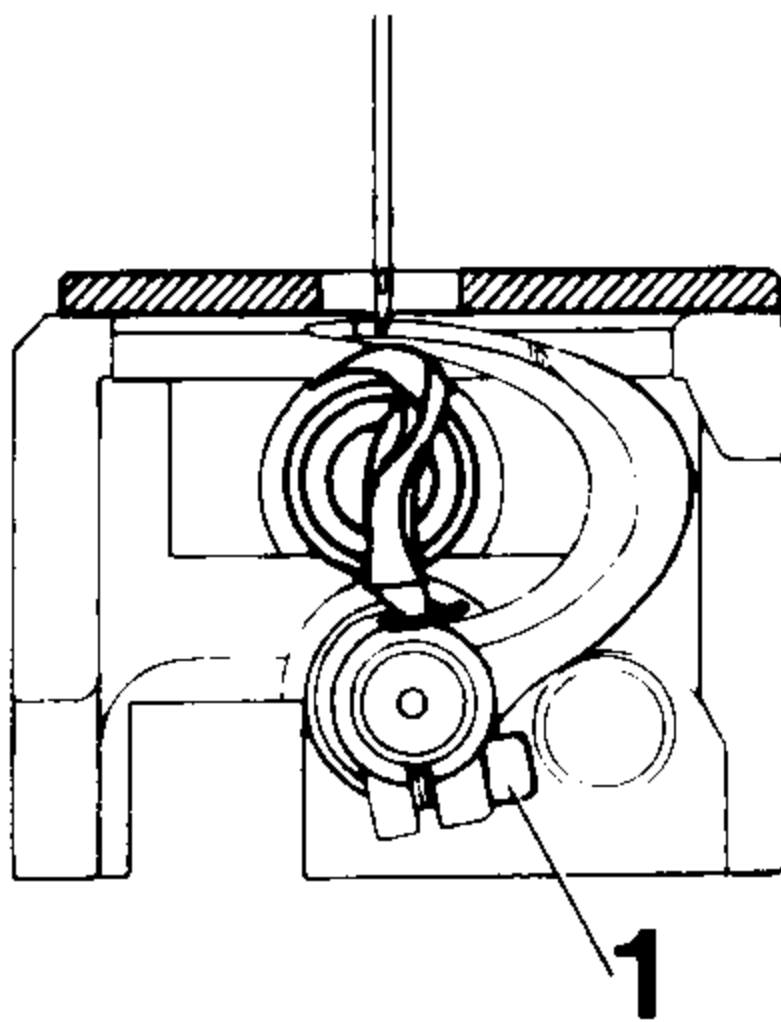

13.0.3

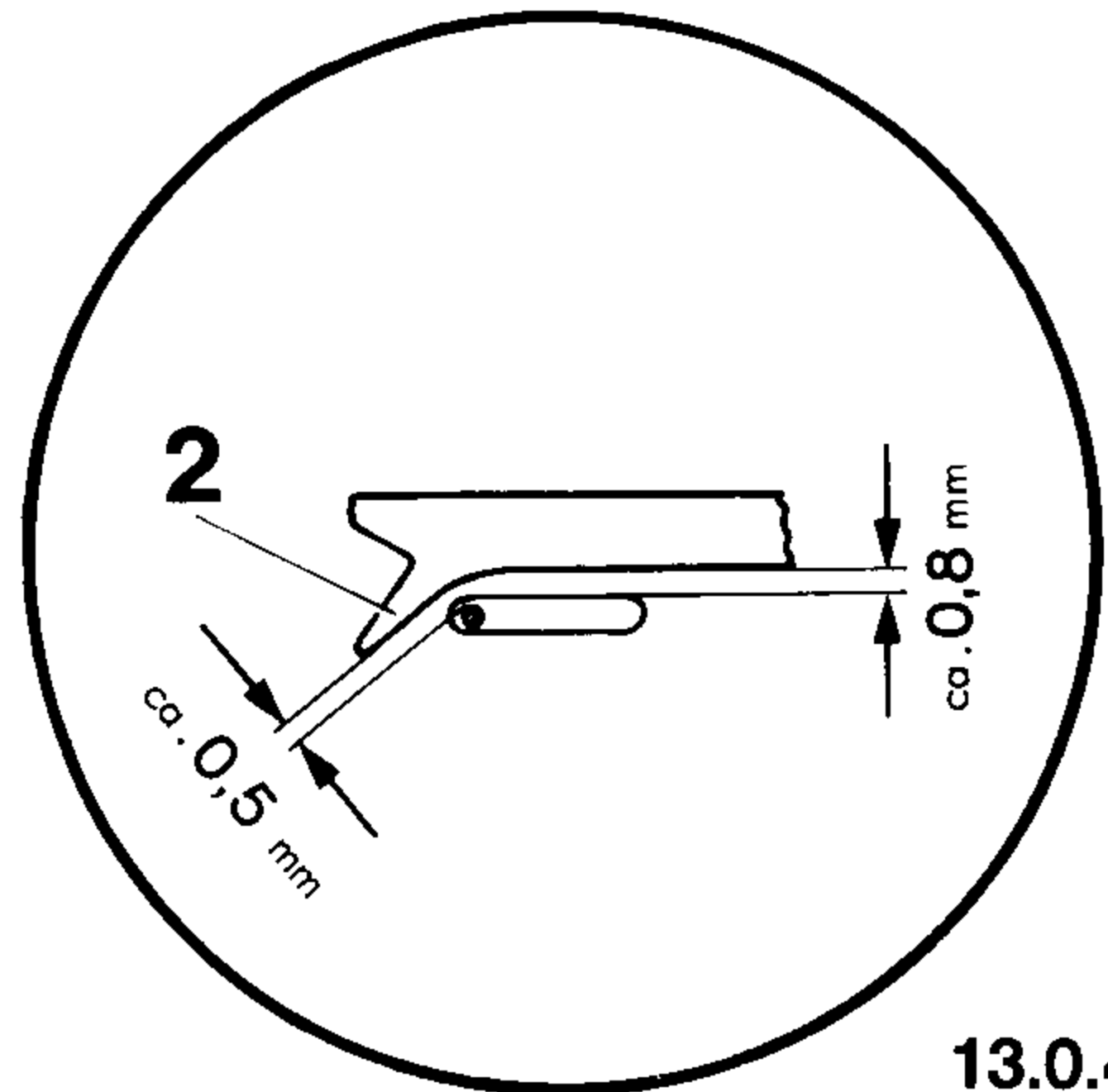

13.0.4

- 13.2.1 Screw on the needle plate and set the widest zigzag stitch.
- 13.2.2 Disengage the stop-motion mechanism and turn the belt pulley in its normal direction until the needle bar is at bottom dead center on the left of its throw.
- 13.2.3 Continue turning the belt pulley in its normal direction until the needle point is flush with the bottom edge of the blind looper (Fig. 13.0.3).
- 13.2.4 **Loosen screw 1 and turn the blind looper so that there is a clearance of approx. 0.5 mm between thread puller hook 2 and the needle.**
- 13.2.5 **Tighten screw 1, making sure there is a clearance of approx. 0.8 mm between the rear edge of the needle slot and the front edge of the blind looper.**
- 13.2.6 Check this adjustment (see "Correct setting").

Correct setting:

With the machine set at the widest stitch, there must be a clearance of approx. **0.5 mm** between thread loop support and needle when the latter is on the right and left of its largest throw (Fig. 14.0.2).

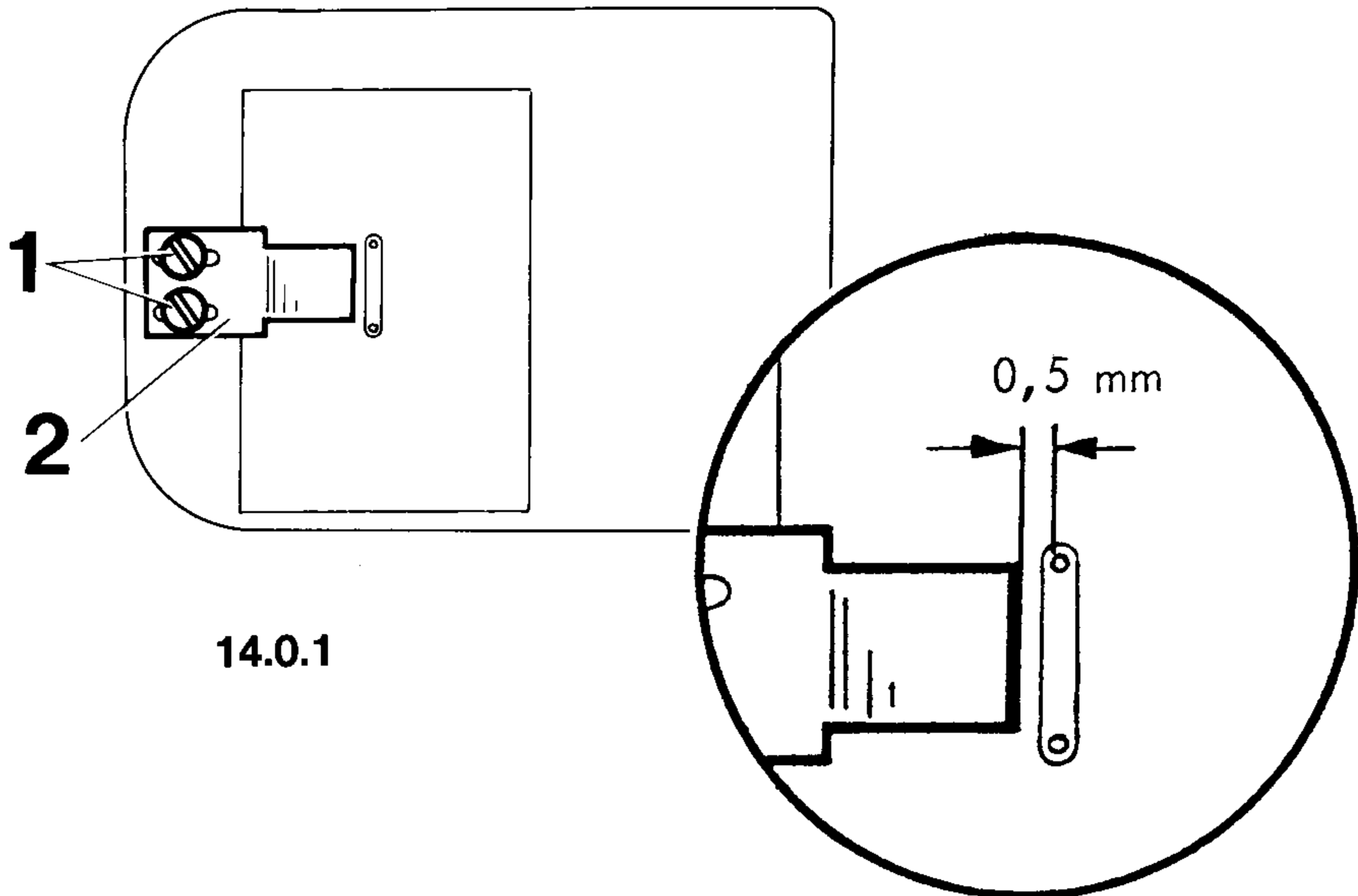

- 14.1 Set the widest stitch and disengage the stop-motion mechanism.
- 14.2 Tilt the machine over.
- 14.3 Set the needle bar at bottom dead center on the left of its throw.
- 14.4 Loosen screws **1** just sufficiently to allow support **2** to be moved against resistance.
- 14.5 **Position thread loop support **2** so that there is a clearance of approx. 0.5 mm between its front edge and the needle, making sure this front edge is parallel to the needle slot (see Fig. 14.0.2).**
- 14.6 **Set the needle bar at bottom dead center on the right of its throw and check that there is a clearance of approx. 0.5 mm between needle and thread loop support **2** (Fig. 14.0.2).**

14.7 Readjust, if necessary.

14.8 Tighten screws **1**.

14.9 Check this adjustment (see "Correct setting").

Note: Depending on the size of thread used, it may be necessary to deviate from this basic setting.

15

Button clamp

(This adjustment does not apply to subcl. -9/.. and 15/..)

Correct setting:

When retaining clamp 4 rests against stop screw 5 and the belt pulley is turned, the needle must enter the middle holes of the gauge button exactly in the center, both lengthwise and crosswise to the arm.

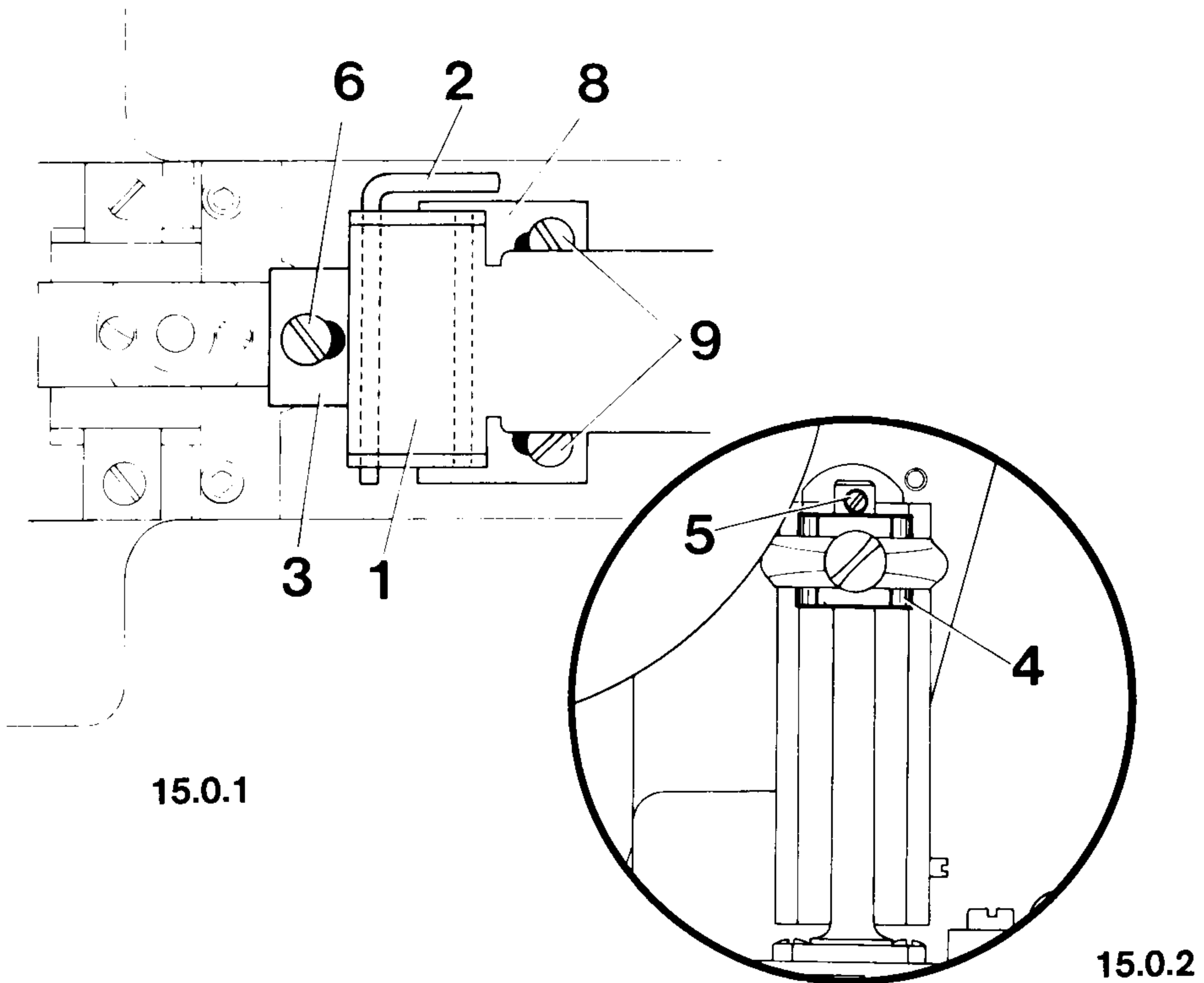

- 15.1 Screw on the feed plate.
- 15.2 Fit button clamp 1.
- 15.3 Push hinge pin 2 through the rear hole in button clamp 1 and the hole in bearing bracket 3.
- 15.4 Insert the gauge button straight and disengage the stop-motion mechanism.
- 15.5 Set the stitch width so that the needle enters the middle holes of the gauge button exactly in the center (crosswise to the arm).
- 15.6 Move retaining clamp 4 up against screw 5.
- 15.7 **Loosen screw 6 and position bearing bracket 3 so that, when the belt pulley is turned, the needle enters the middle holes of the gauge button exactly in the center (lengthwise to the arm) (Fig. 15.0.3).**

- 15.8 In this position, tighten screw 6.
- Note: Slight crosswise adjustment of the button clamp is possible after loosening screws 7.
- 15.9 Pull out hinge pin 2 and push it through the front hole of button clamp 1 and the hole of bracket 8.
- 15.10 **Loosen screws 9 and position bearing bracket 8 so that, when the belt pulley is turned, the needle enters the middle holes of the gauge button exactly in the center (lengthwise to the arm) (Fig. 15.0.3).**
- 15.11 In this position tighten screw 9.
- 15.12 Remove the gauge button.

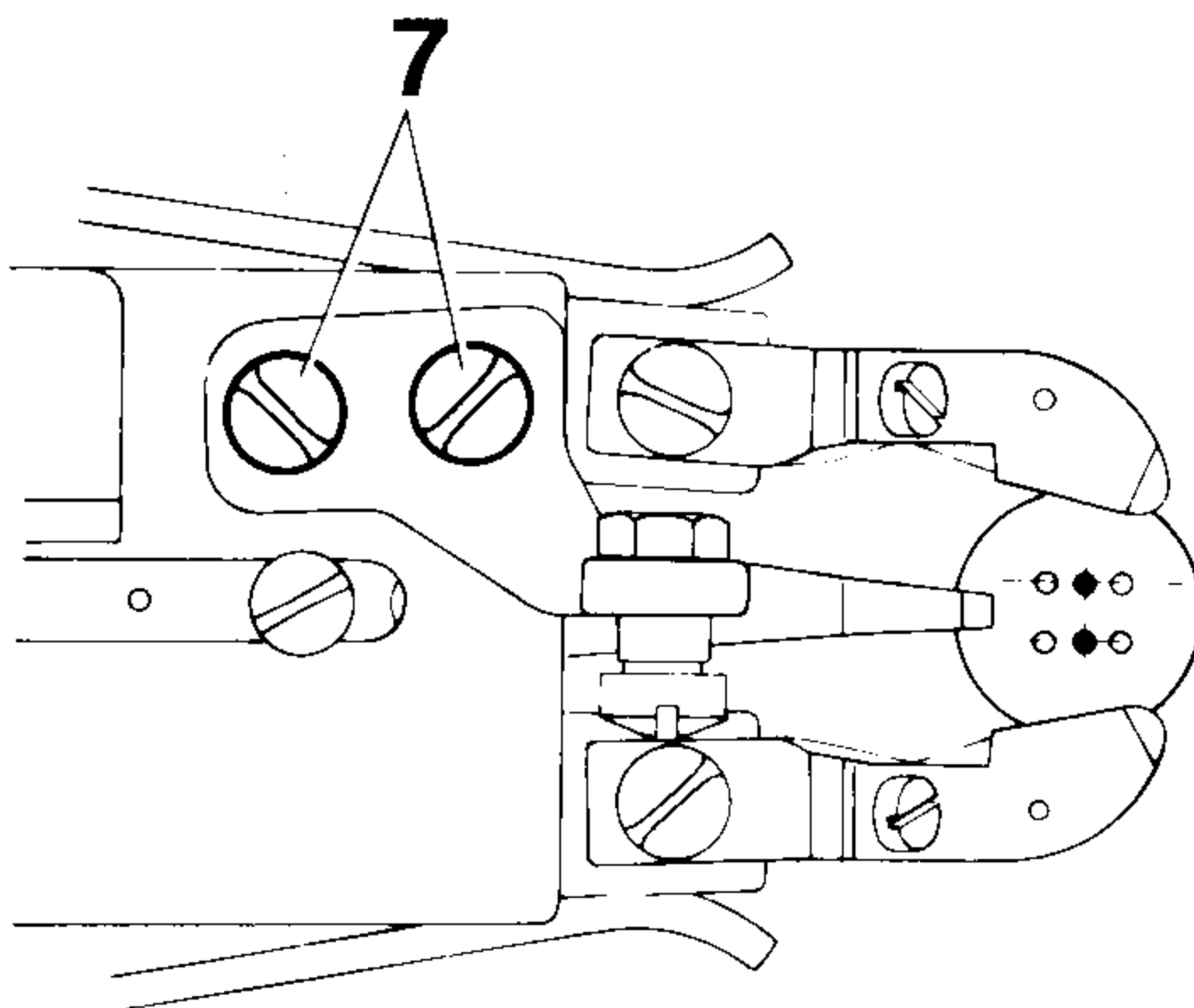

15.0.3

16

Presser bar

(This adjustment does not apply to subclass -9/..)

Correct setting:

With the button clamp raised, there must be a clearance of **13 mm** between button clamp and feed plate.

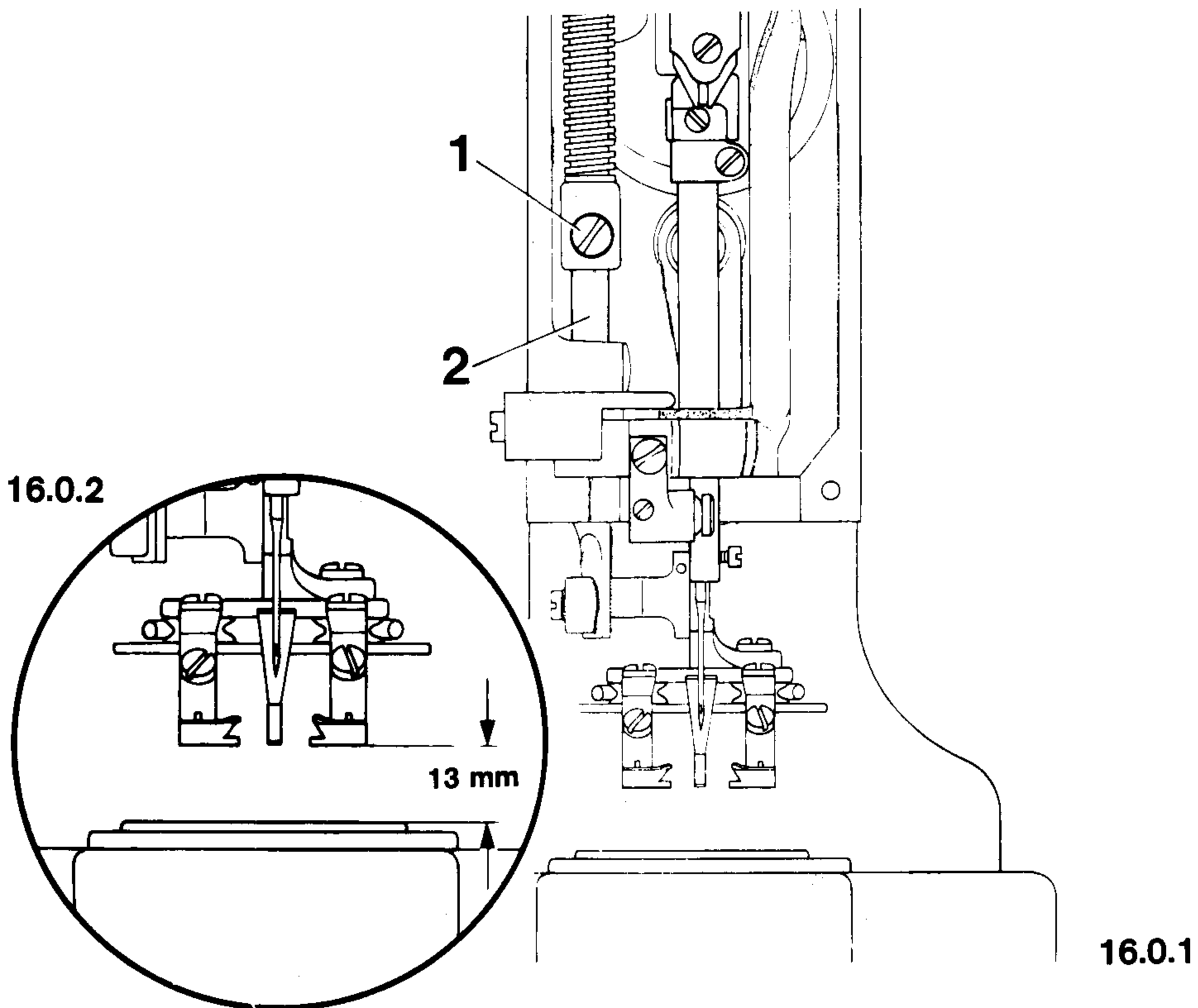

- 16.1 Engage stop-motion mechanism and remove the face plate.
- 16.2 Operate the pedal to raise the button clamp.
- 16.3 On machines with electro-magnetic or electro-pneumatic control remove the V-belt and turn on the master switch.
- 16.4 Loosen screw 1.
- 16.5 **Adjust the height of presser bar 2, without turning it, so that there is a clearance of 13 mm between button clamp and feed plate.**
- 16.6 Tighten screw 1.
- 16.7 Check this adjustment (see "Correct setting").
- 16.8 Replace the face plate.
- 16.9 Replace the guard on the face plate.
- 16.10 Switch off the master switch and replace the V-belt.

17 Thread trapper push rod

Note: To check this adjustment the arm cover must be removed.

Correct setting:

There must be a clearance of approx. **10 mm** between the top of collar **3** and the arm cover. Between bush **5** and collar **6** there must be a clearance of approx. **18 mm**.

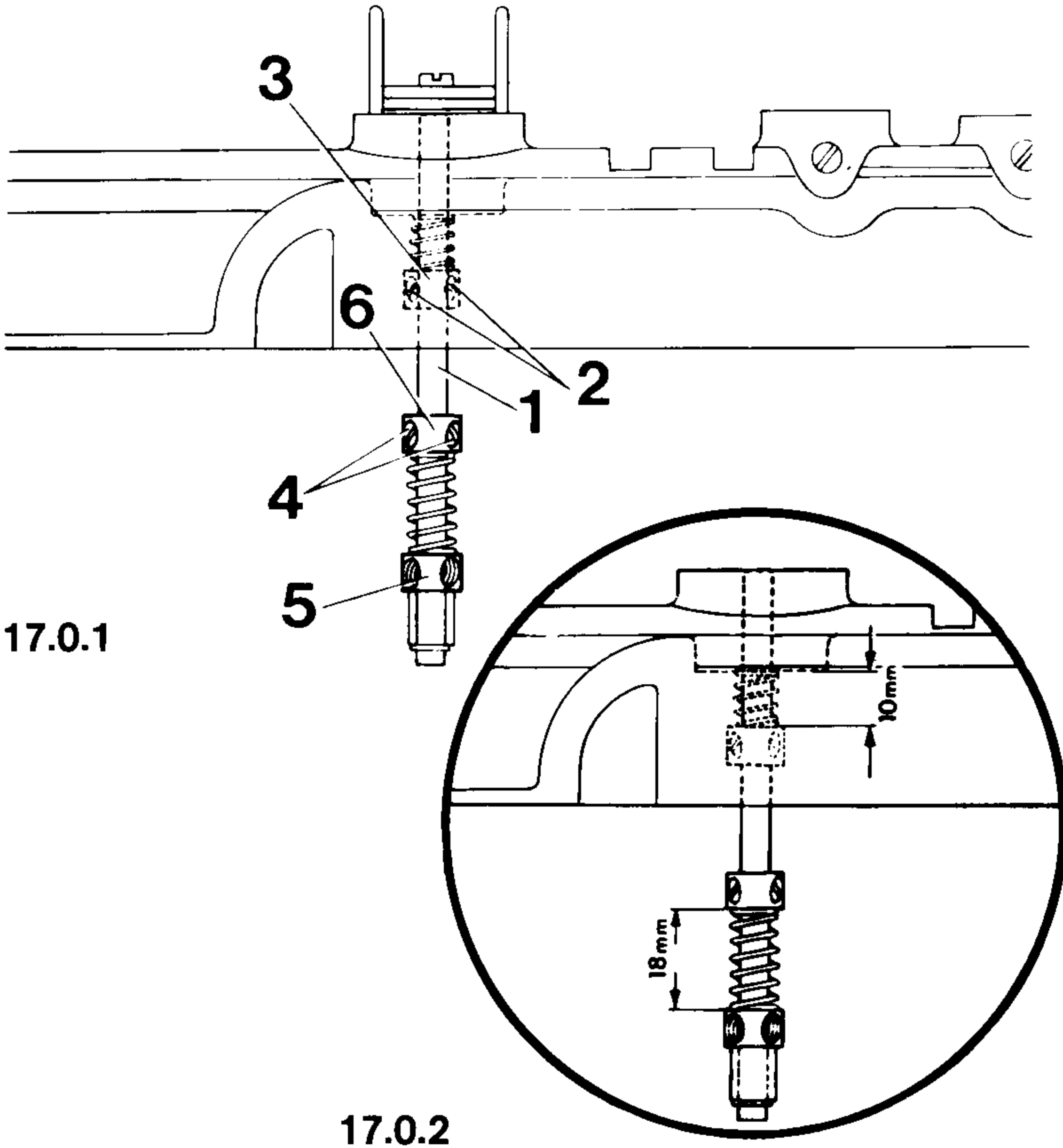

- 17.1 Engage stop-motion mechanism and remove the arm cover.
- 17.2 Pull rod 1 down as far as it will go.
- 17.3 **Loosen screws 2 and adjust collar 3 until there is a clearance of approx. 10 mm between it and the arm cover (Fig. 17.0.2).**
- 17.4 In this position, tighten screws 2.
- 17.5 Loosen screws 4.
- 17.6 **Set a clearance of approx. 18 mm between bush 5 and collar 6 (Fig. 17.0.2).**
- 17.7 In this position, tighten screws 4.
- 17.8 The arm cover is left off for the next adjustment.

Correct setting:

The thread tension must begin to open **8 to 10 mm** before top dead center of the needle bar, and must be closed again **8 to 10 mm** past top dead center.

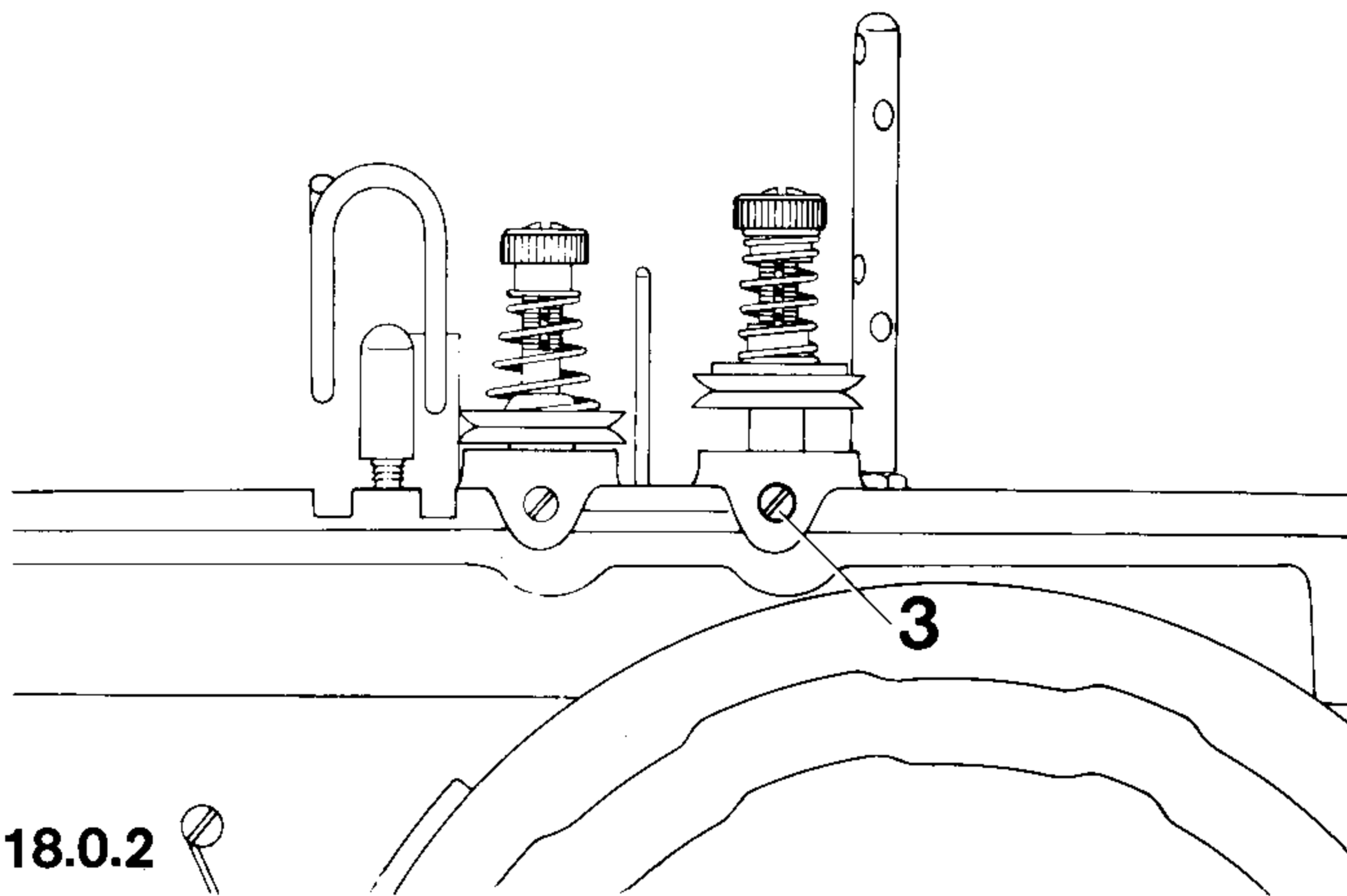
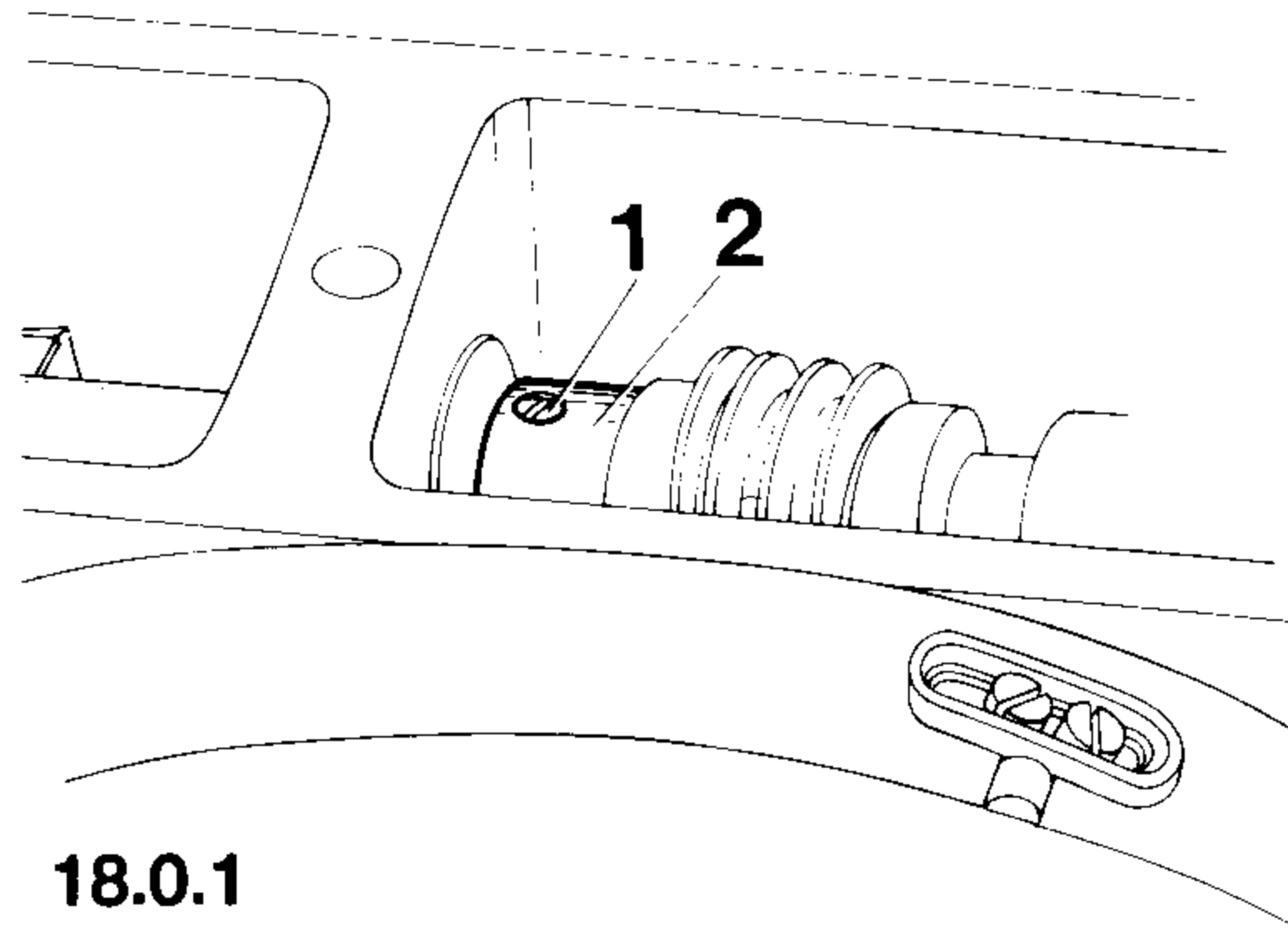

- 18.1 Loosen screw **1** just sufficiently to allow eccentric **2** to be turned against resistance.
- 18.2 Set the needle bar at top dead center.
- 18.3 Turn eccentric **2** so that its lobe is facing up.
- 18.4 Tighten screw **1**.
- 18.5 Replace the arm cover and secure it in position with two screws, making sure that push rod **9** (Fig. 20.0.1) enters lever **8**.
- 18.6 Disengage stop-motion mechanism and position the needle bar **10 mm** before top dead center.
- 18.7 Loosen screw **3** and position the thread tension so that the release pin just touches eccentric **2**.
- 18.8 In this position, tighten screw **3** securely.
- 18.9 Check this adjustment (see "Correct setting").
- 18.10. Replace all arm cover screws.

Correct setting:

The movement of the button clamp lengthwise to the arm must be completed when the needle point enters the button.

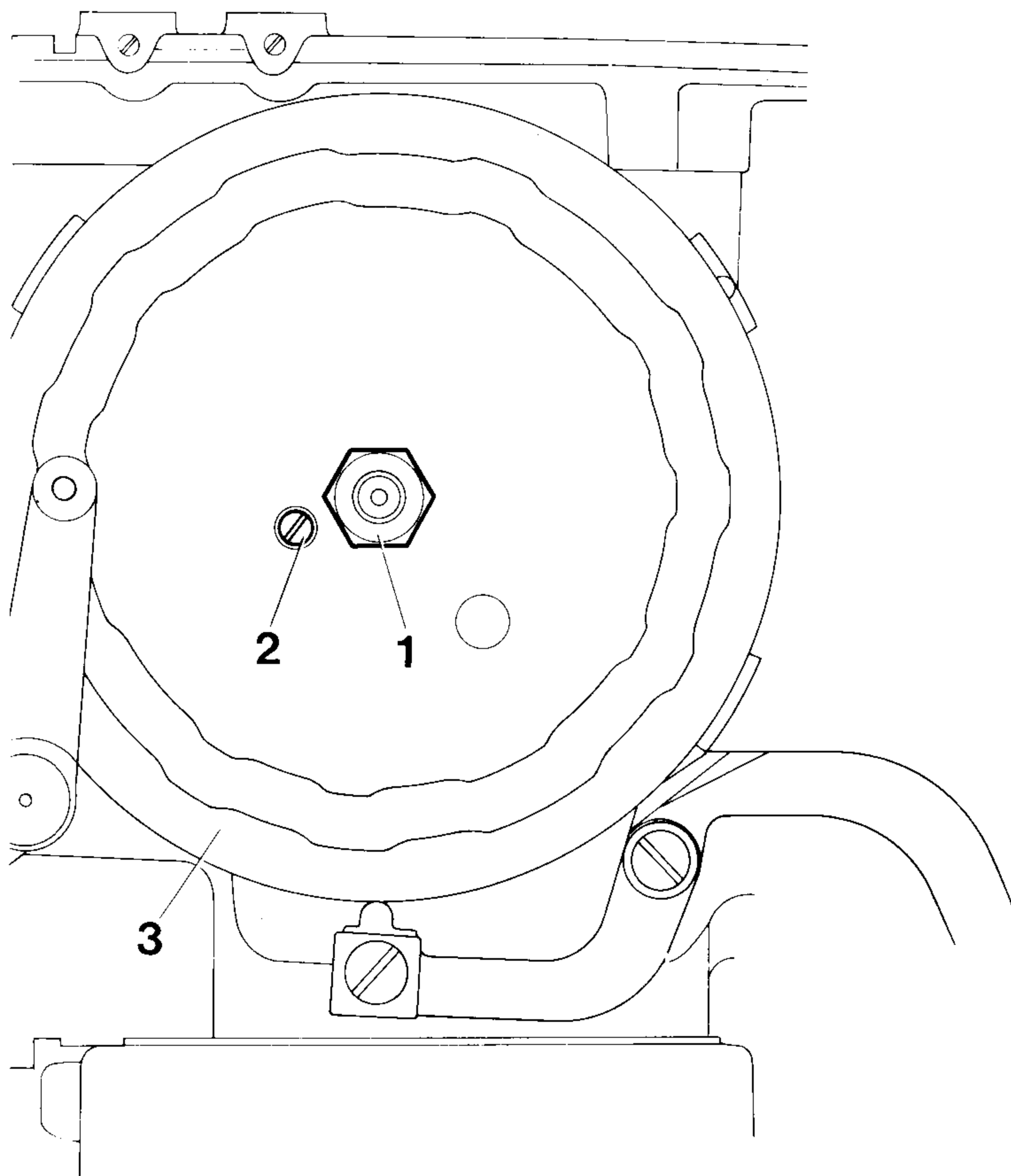

- 19.1 Place a piece of fabric in the machine and insert a button in the clamp.
- 19.2 Disengage the stop mechanism and turn the belt pulley in its normal direction, checking the movement of the button clamp lengthwise to the arm.
- 19.3 If the movement does not coincide with "Correct setting", proceed as follows:
 - 19.3.1 Loosen nut 1 and threaded stud 2.
 - 19.3.2 **Turn control cam 3 so that the arm-lengthwise movement of the button clamp is completed when the needle enters the button.**
 - 19.3.3 Tighten screw 2 securely.
- 19.4 Check this adjustment (see "Correct setting").
- 19.5 Tighten nut 1.

Correct setting:

The thread trapper must be adjusted so that the thread is firmly held at the end of the cycle with the stop mechanism in its locked position.

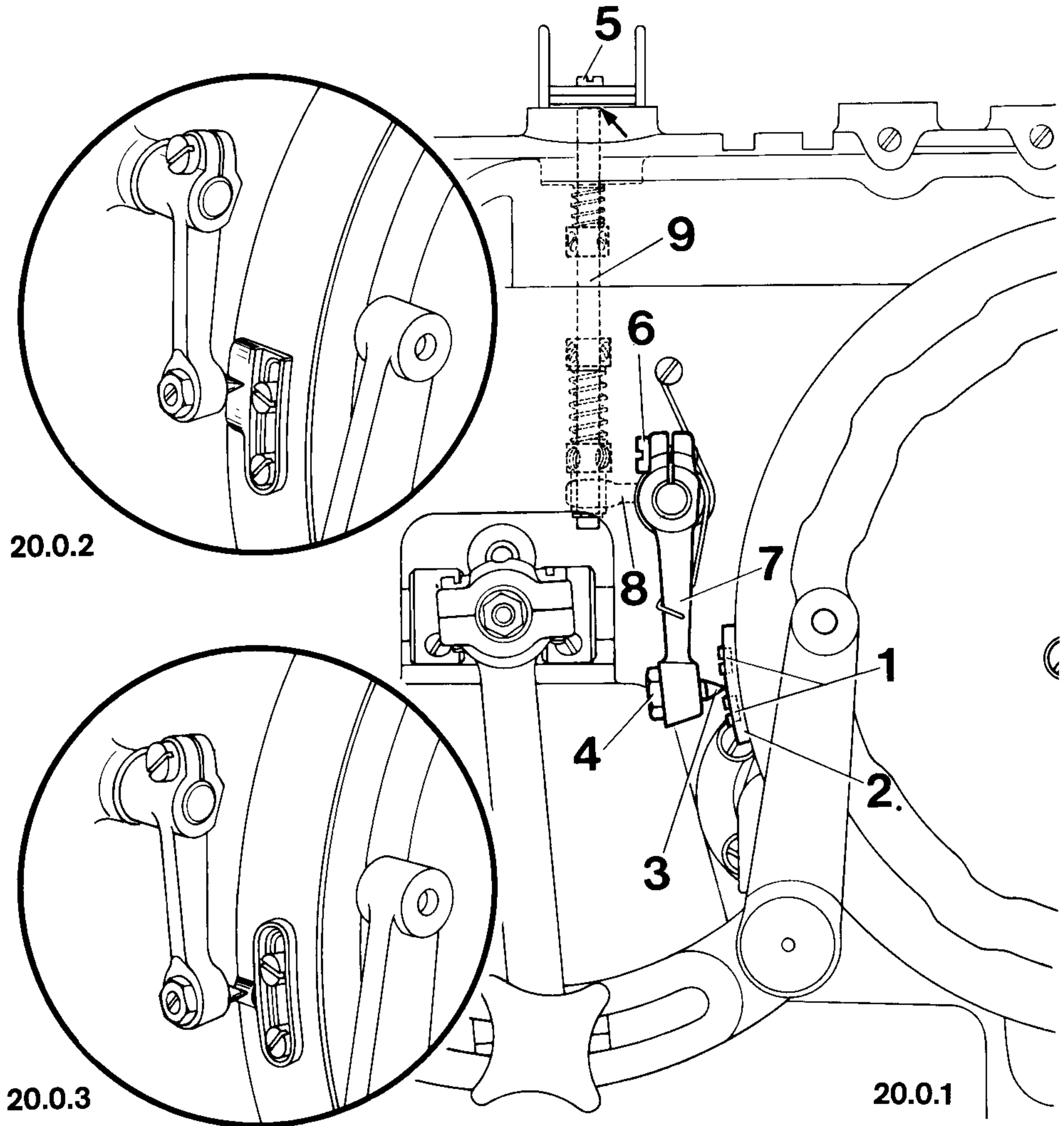

- 20.1 Set machine at end-of-cycle position and engage stop-motion mechanism.
- 20.2 Loosen screws 1 and position thread trapper actuating segment 2 so that center screw 3 is positioned in the middle (on subcl. -108/01 machines at the highest point) of actuating segment 2 (Figs. 20.0.2 and 20.0.3 respectively).

- 20.3 In this position, tighten screws **1**.
- 20.4 Loosen locknut **4** and screw center screw **3** in so that it is flush with locknut **4** when the latter is tightened.
- 20.5 Tighten locknut **4**.
- 20.6 Screw out screw **5** and remove clamping discs with spacer.
- 20.7 Disengage the stop mechanism and turn the belt pulley in its normal direction until screw **3** no longer rests on segment **2**.
- 20.8 Loosen clamp screw **6** and turn lever **7** so that center screw **3** is against the cam.
- 20.9 Making sure the point of screw **3** contacts the cam, turn lever **8** (accessible through the opening in the arm) so that push rod **9** is flush with the top edge of the arm cover (see arrow).
- 20.10 In this position, tighten clamp screw **6**, making sure there is no end play.
- 20.11 Replace the two clamping discs with the spacer and insert and tighten screw **5**.
- 20.12 Set the machine at the end of the sewing cycle and allow the stop motion lever to engage.
- 20.13 Check this adjustment (see "Correct setting").

21 Thread trapper actuating segment

Note: This adjustment is omitted on subcl. -108/01 machines.

Correct setting:

The thread trapper must be open when the needle bar is at a position **10 mm** past top dead center.

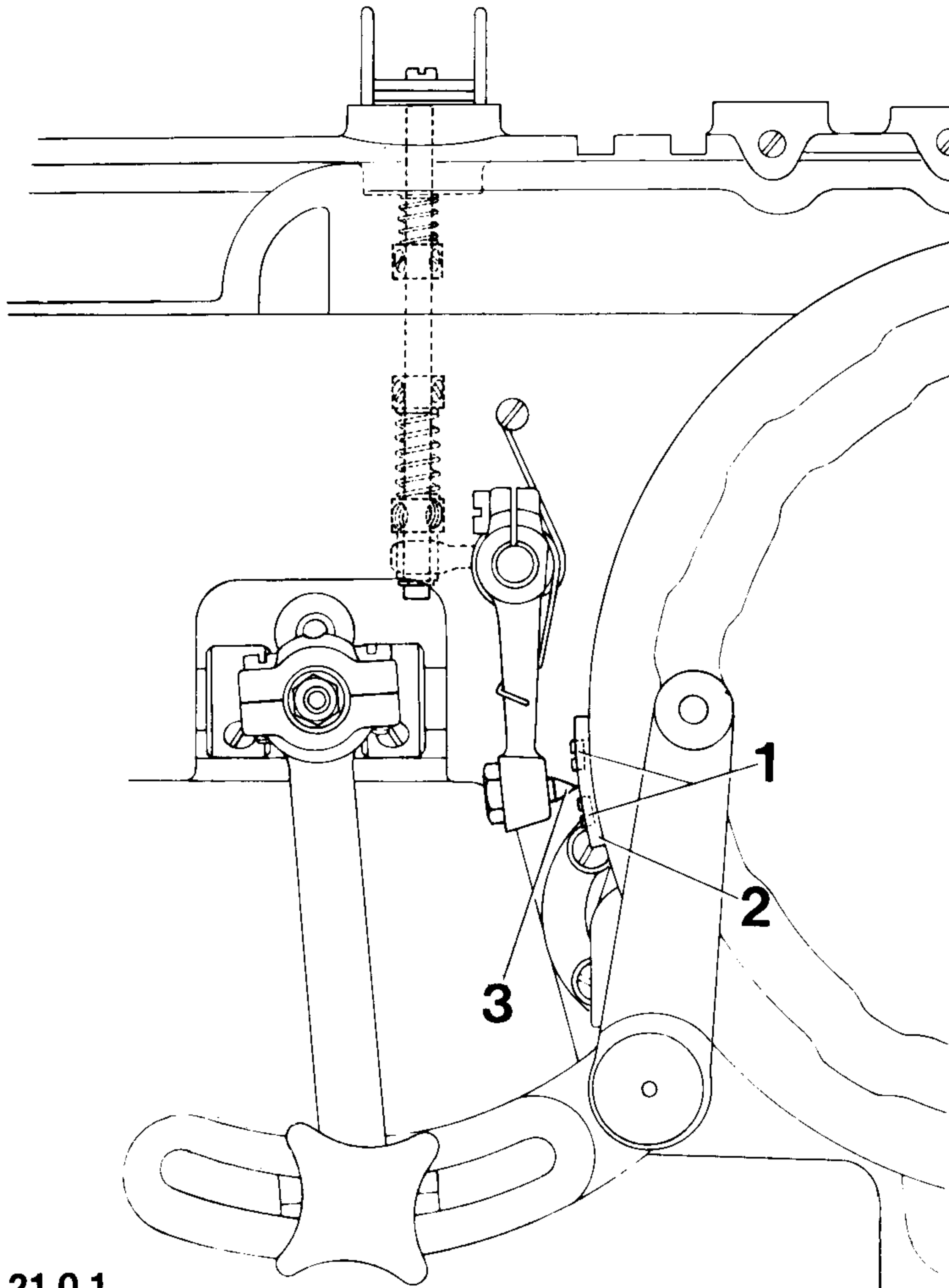

21.0.1

- 21.1 Set machine at end-of-cycle position and engage stop-motion mechanism.
- 21.2 Disengage the stop-motion mechanism and turn the belt pulley to set the needle bar at a position **10 mm** past top dead center.

- 21.3 Loosen screws 1 and adjust the position of thread trapper actuating segment 2 so that the point of center screw 3 contacts the control cam (Fig. 21.0.2).
- 21.4 In this position, tighten screws 1.
- 21.5 Check this adjustment (see "Correct setting").

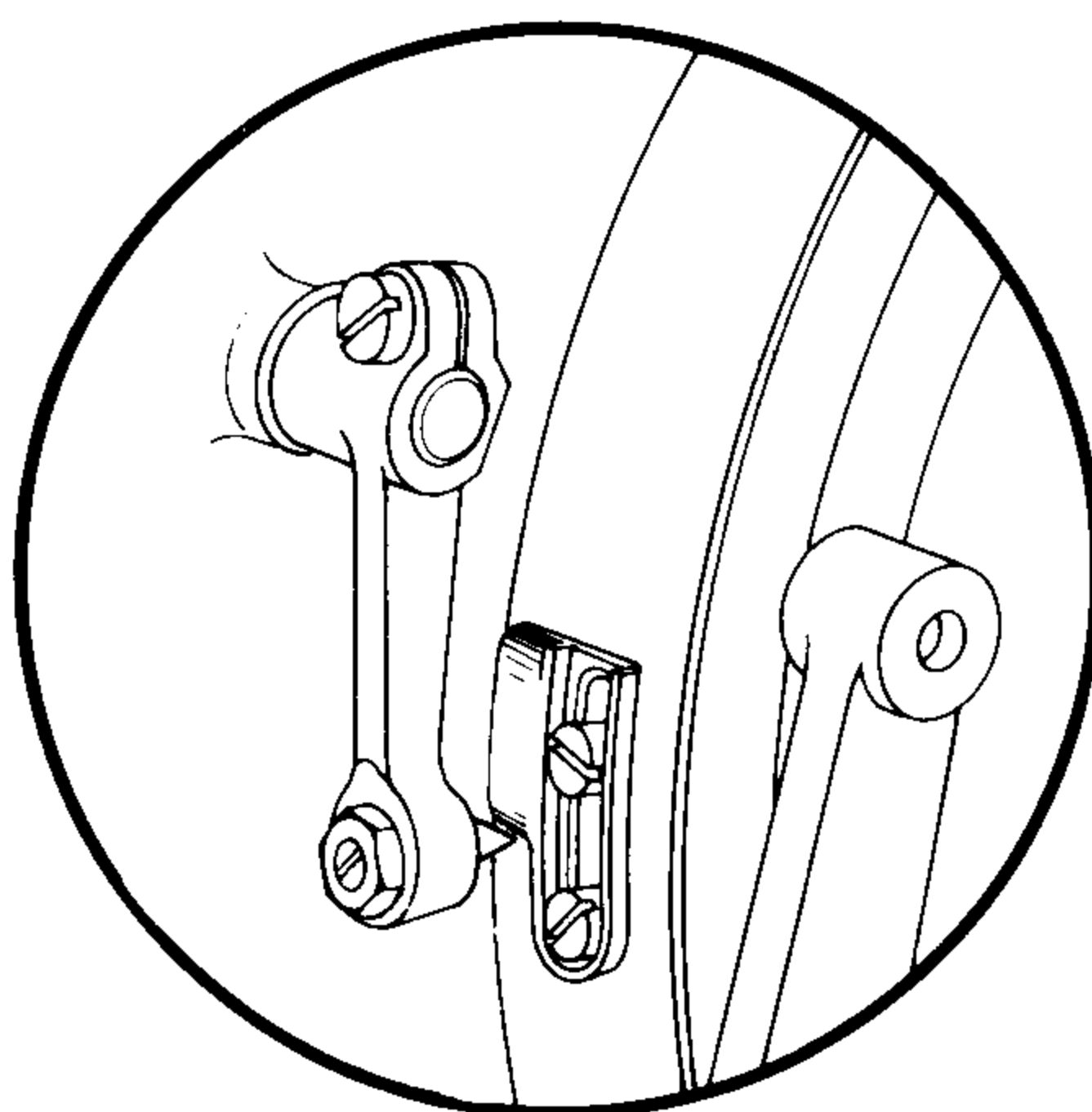

21.0.2

22 Stop mechanism

22.1 V-belt pulley

Correct setting:

When stop link 2 is at the highest point of stop cam 1 V-belt pulley 5 must just be released from drive pulley 6.

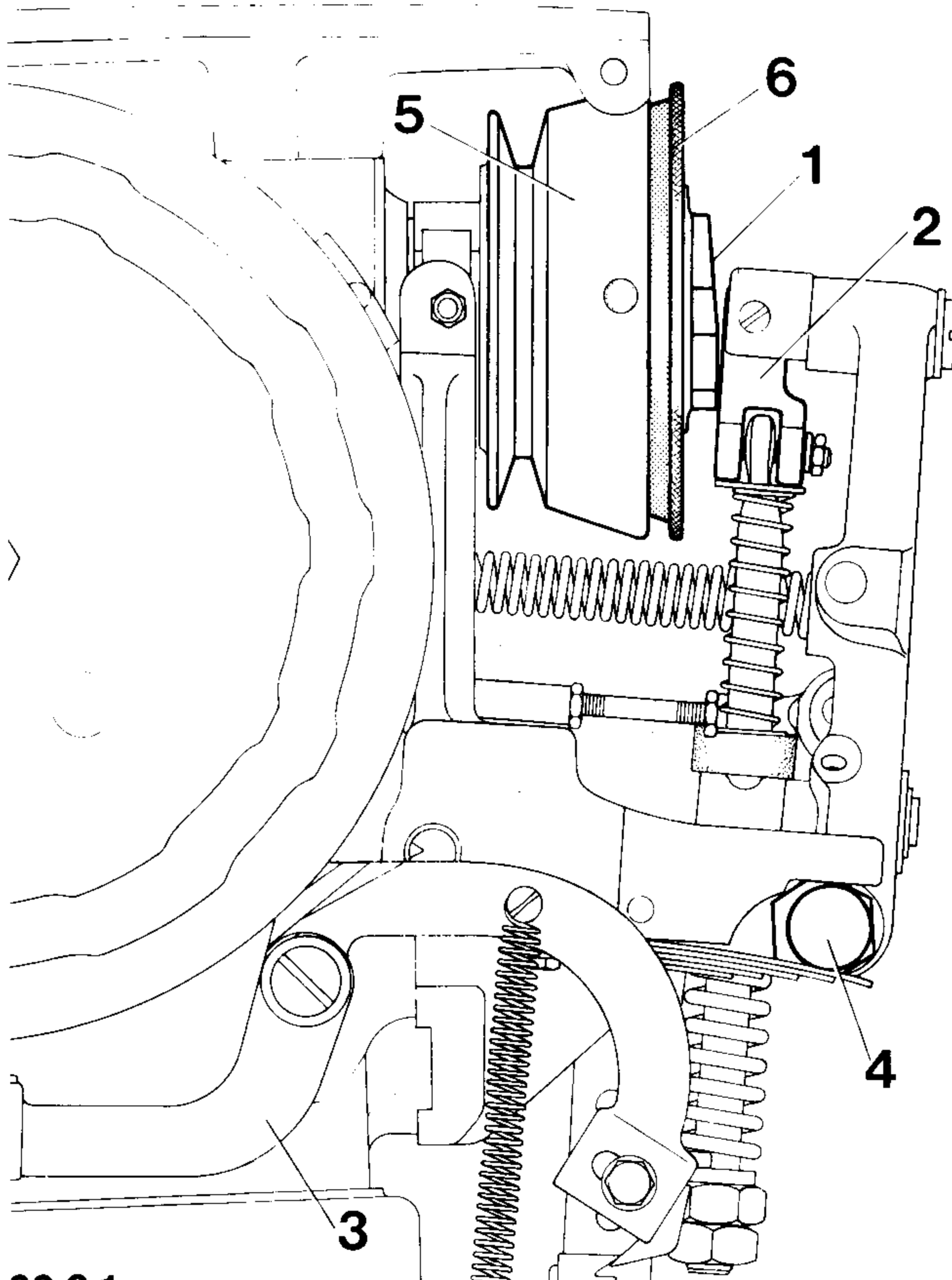

22.0.1

- 22.1.1 Disengage stop-motion mechanism and turn the belt pulley in its normal direction until the highest point of stop cam 1 is positioned opposite stop link 2.
- 22.1.2 Operate lever 3 to move stop link 2 against cam 1.
- 22.1.3 **Loosen the locknut of eccentric 4 and turn the latter so that belt pulley 5 is just released from drive pulley 6.**
- 22.1.4 In this position, tighten the locknut again.

22.2

Clearance between stop link and cam

Correct setting:

With the stop mechanism disengaged, there must be a clearance of approx. **1 mm** between the highest point of stop cam **1** and stop link **2**.

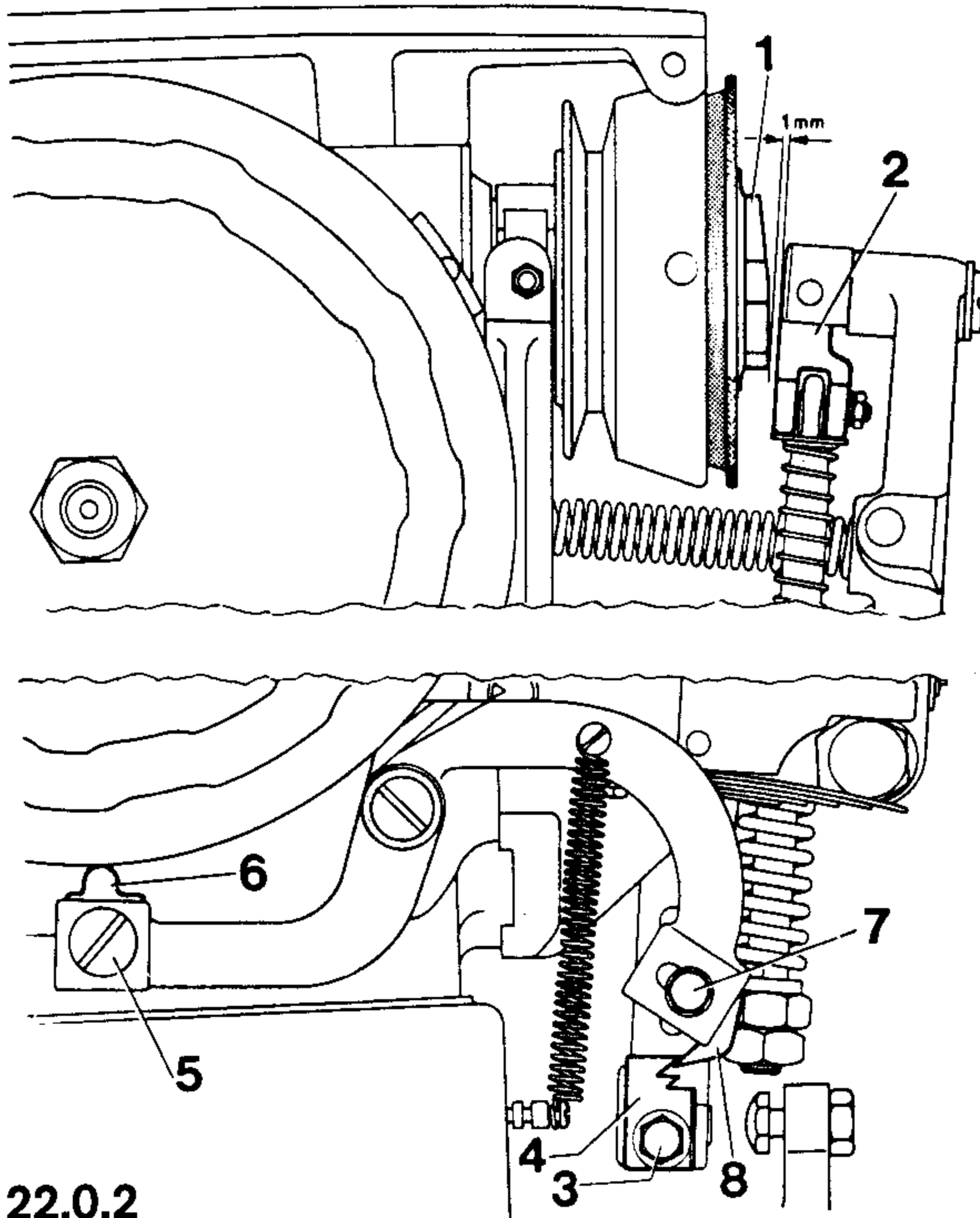

22.0.2

- 22.2.1 Engage stop-motion mechanism.
- 22.2.2 To obtain a clearance of approx. **1 mm**, place a 1.6 mm thick feeler gauge between cam **1** and stop link **2**.
- 22.2.3 Loosen screw **3** and position catch **4** so that screw **3** is in the middle of the elongated hole in catch **4**.
- 22.2.4 Tighten screw **3**.
- 22.2.5 Loosen screw **5** and push stop **6** downwards.
- 22.2.6 Loosen screw **7** and position latch **8** so that it enters the upper notch of catch **4** halfway.
- 22.2.7 Tighten screw **7**.
- 22.2.8 In this position, move stop **6** up against the cam and tighten screw **5**.
- 22.2.9 Remove the feeler gauge and check this adjustment (see "Correct setting").

Correct
setting:

From the point of engagement of the stop mechanism to the point of engagement of stop link 1 stop cam 2 must make another $3/4$ of a turn.

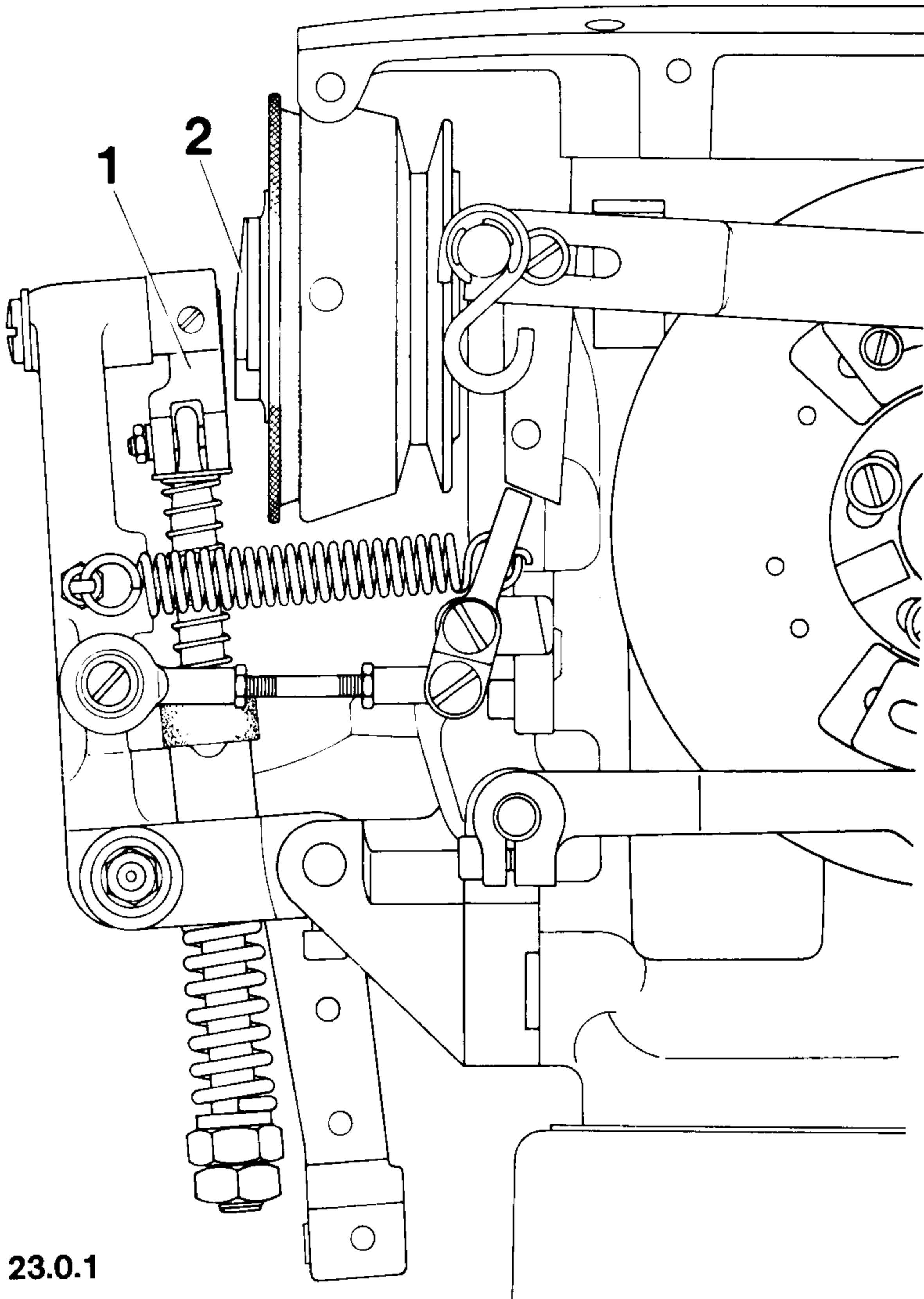

23.0.1

- 23.1 Set machine at end-of-cycle position and engage stop-motion mechanism.
- 23.2 Disengage the stop-motion.
- 23.3 Turn the belt pulley contrary to its normal direction until the stop mechanism is engaged.

- 23.4 Disengage the stop mechanism again and turn the belt pulley in its normal direction until stop link 1 moves against cam 2.
- 23.5 Check the position of the cam (Fig. 23.0.2).
- 23.6 If the cam is not in the correct position, loosen screws 3 and adjust trip 4 accordingly.
- 23.7 Tighten screws 3 securely.
- 23.8 Check this adjustment (see "Correct setting").
- Note: On machines with several trips, each one has to be adjusted separately.

23.0.2

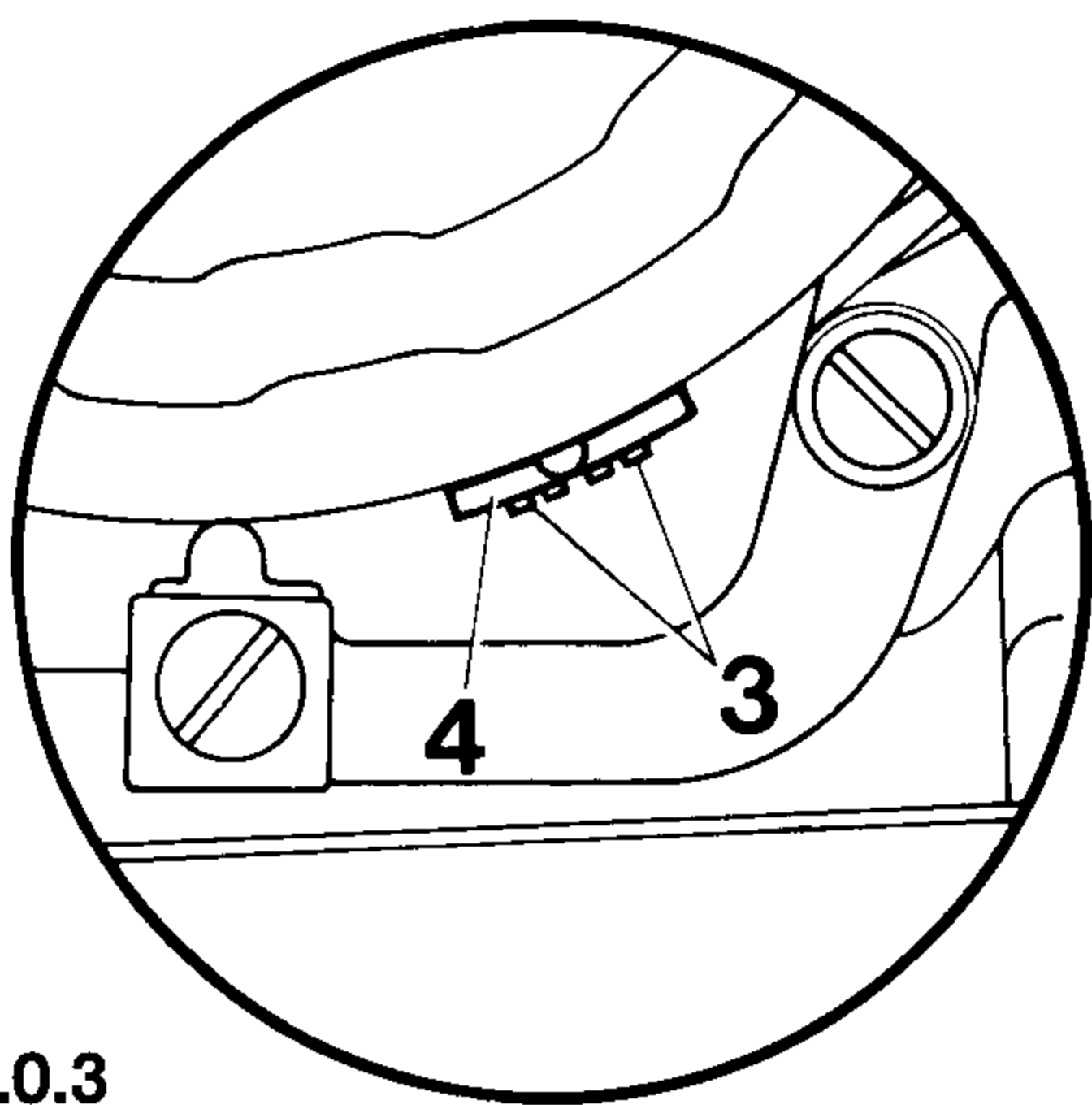
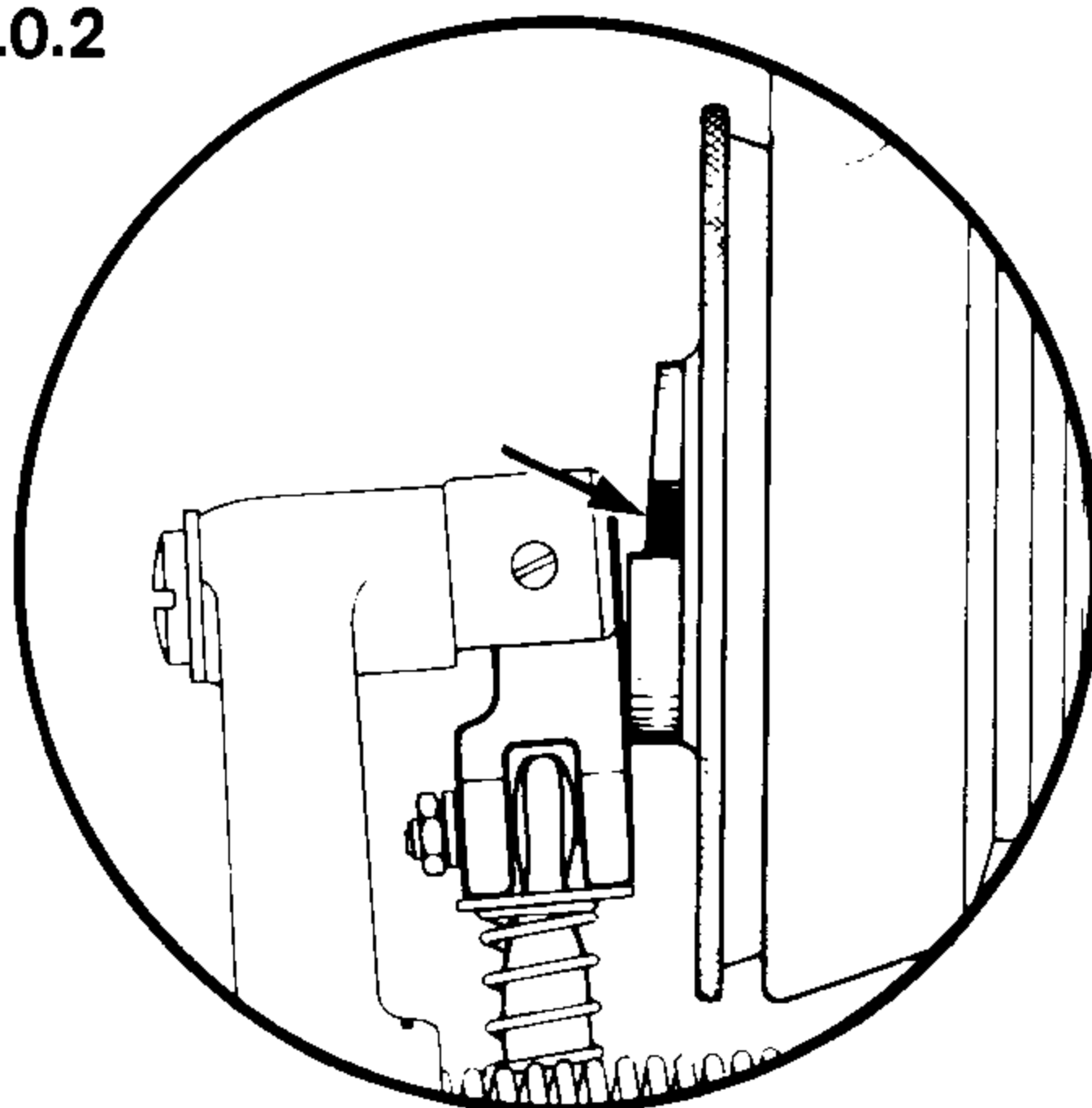

23.0.3

Correct setting:

When lever 3 contacts stop 4 there must be a clearance of approx. **2 mm** between stop link 6 and the highest point of stop cam 5 (Fig. 24.0.2).
In the end-of-cycle position and with the stop mechanism engaged, there must be a clearance of about **1.5 mm** between screw 2 and thrust piece 9.

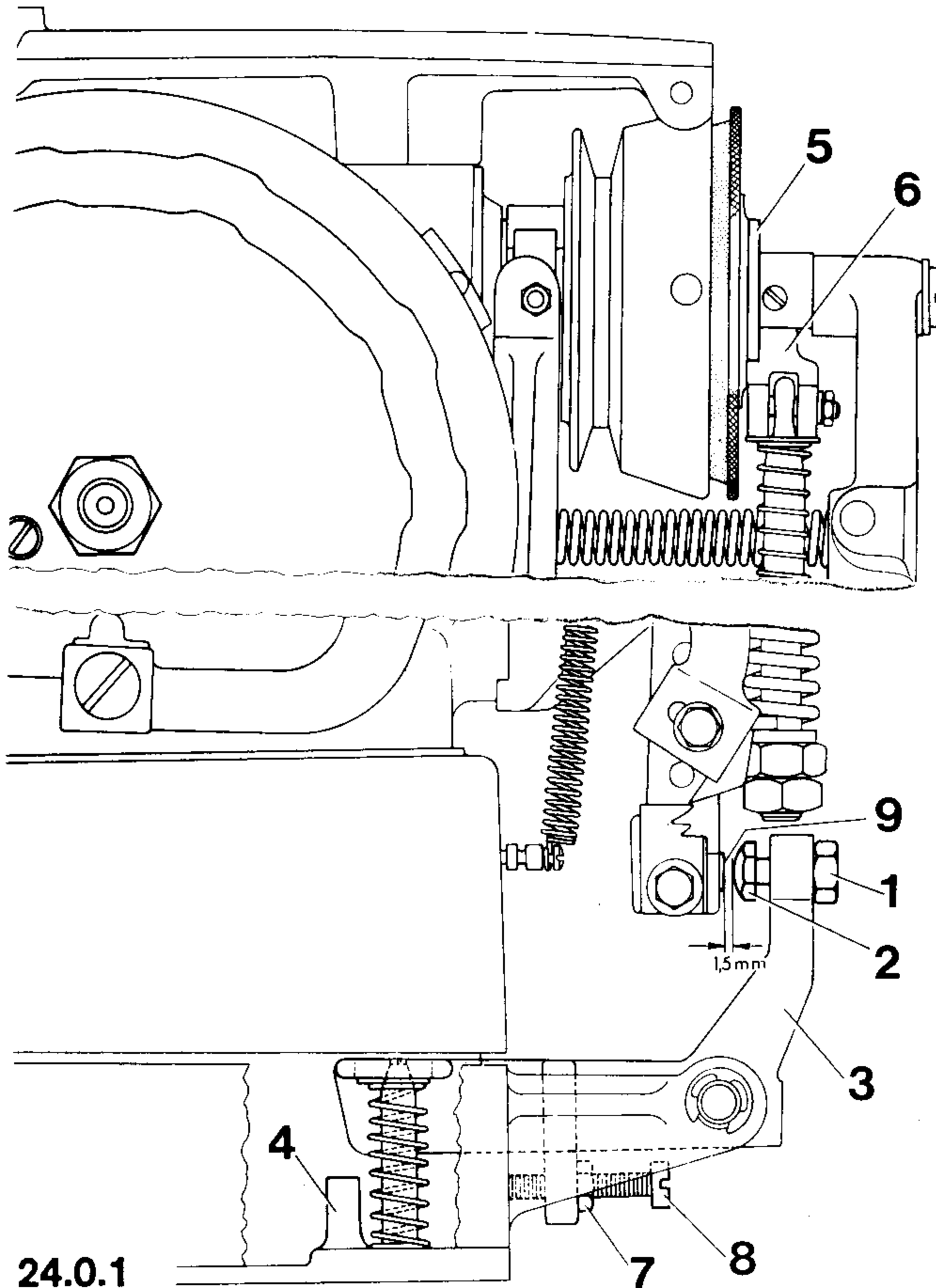

- 24.1 Set machine at end-of-cycle position and engage stop-motion mechanism.
- 24.2 Loosen locknut 1 and turn screw 2 fully back.
- 24.3 Disengage stop-motion mechanism and move lever 3 up against stop 4.
- 24.4 Turn the belt pulley in its normal direction until the highest point of cam 5 is opposite stop link 6.

- 24.5 Turn screw 2 so that there is a clearance of 2 mm between stop link 6 and the highest point of cam 5 (Fig. 24.0.2).

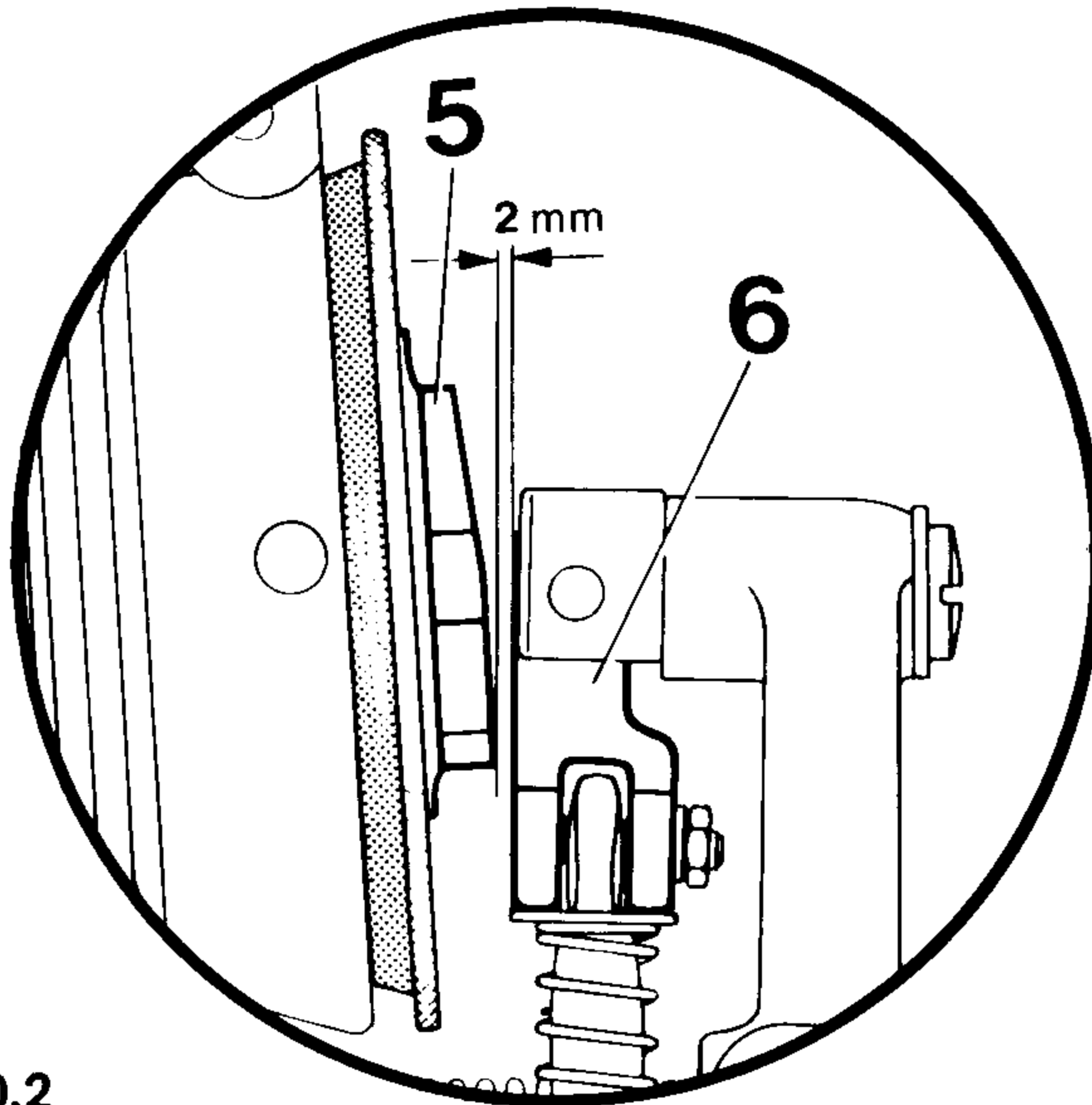

24.0.2

- 24.6 Tighten locknut 1.
- 24.7 Release lever 3 and allow the stop mechanism to engage.
- 24.8 Loosen locknut 7.
- 24.9 Turn adjusting screw 8 until there is a clearance of 1.5 mm between screw 2 and thrust piece 9.
- 24.10 Tighten locknut 7 and check this adjustment (see "Correct setting").

25

Locking lever

For machines with -966/13 see section 29.

Correct setting:

With the stop mechanism engaged, there must be a clearance of approx. **1 mm** between locking lever **4** and stop **5**. With the stop mechanism disengaged, there must be a clearance of about **0.3 mm** between locking lever **4** and stop **5** (Fig. 25.0.2).

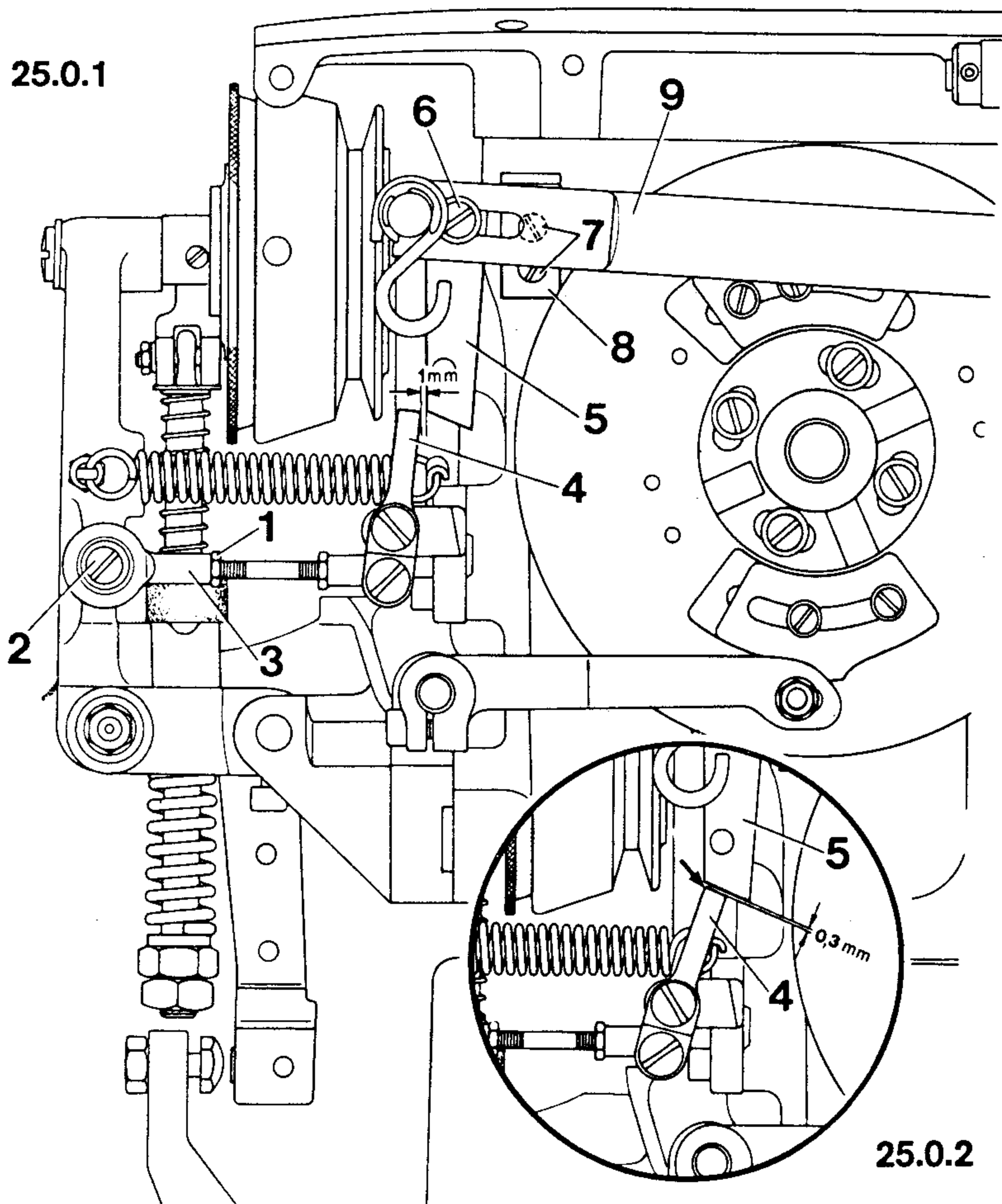

- 25.1 Engage stop-motion mechanism and loosen locknut 1.
- 25.2 Loosen screw 2.
- 25.3 Turn ball joint 3 so that there is a clearance of approx. 1 mm between locking lever 4 and stop 5.

- 25.4 Screw in screw **2** and tighten locknut **1** in this position.
- 25.5 Disengage the stop mechanism and loosen screw **6**.
- 25.6 Position stop **5** so that its rear edge is flush with the back edge of locking lever **4** (see arrow in Fig. 25.0.2).
- 25.7 Tighten screw **6**.
- 25.8 **Loosen screws 7 and adjust stop bracket 8 so that there is a clearance of approx. 0.3 mm between stop 5 and locking lever 4 (Fig. 25.0.2).**
- 25.9 In this position, tighten the accessible screw **7**.
- 25.10 Engage the stop mechanism, push lifting lever **9** downwards and tighten the second screw **7**, too.
- 25.11 Check this adjustment (see "Correct setting").

Declutching mechanism

Correct setting:

The belt pulley must be released from the drive pulley $1\frac{1}{2}$ to 2 stitches before the end of cycle.
 At the end of cycle and with the stop mechanism disengaged there must be a clearance of approx. **1 mm** between roller **6** and segments **2** and **3** (Fig. 26.0.2).
 The clearance between the lug of segment **2** and roller **6** must be approx. **0.5 mm** (Fig. 26.0.3).

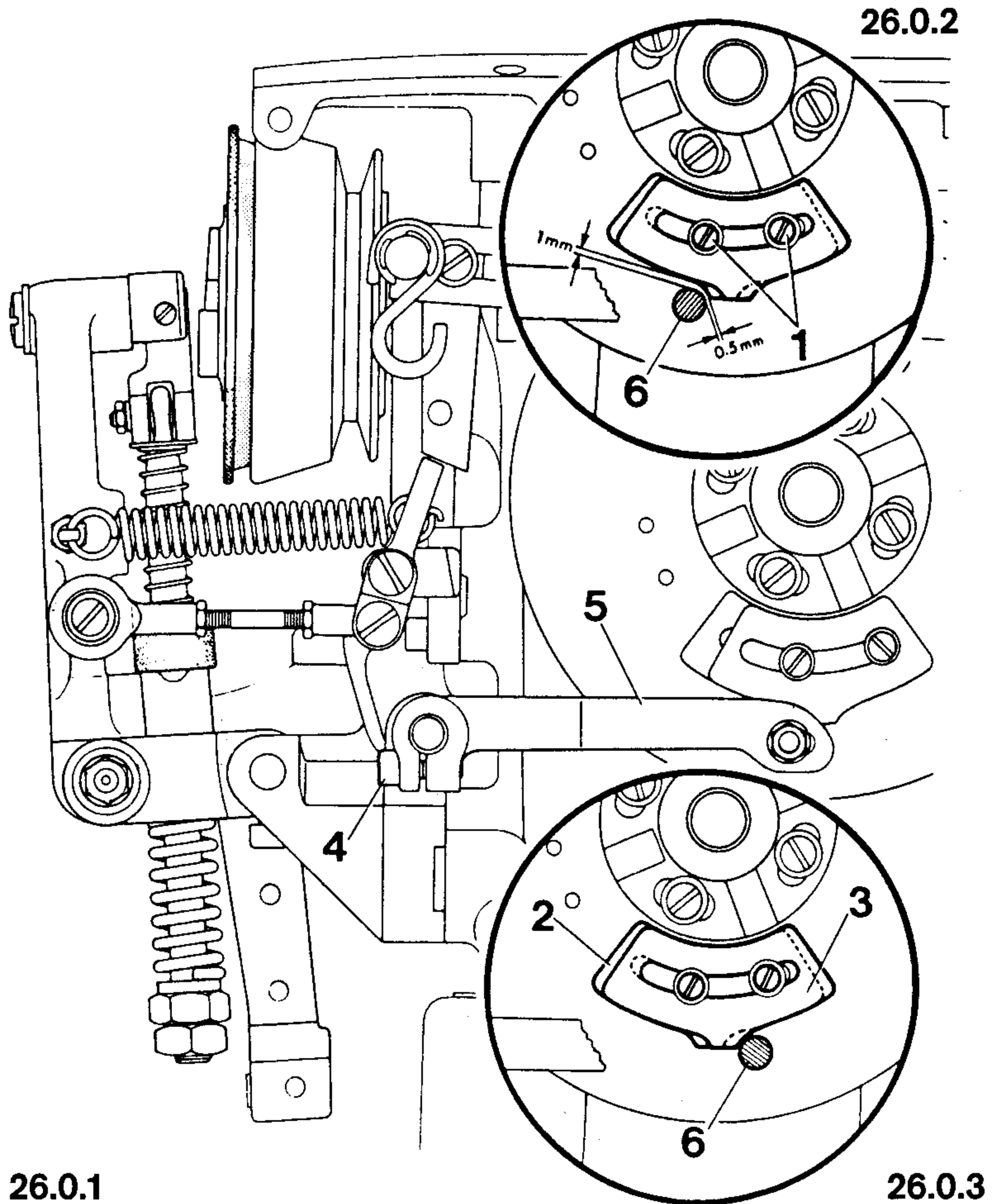

26.1

Set machine at end-of-cycle position and engage stop-motion mechanism.

26.2

Disengage the stop-motion mechanism.

26.3

Loosen screws **1** a little and adjust segments **2** and **3** so that screws **1** are centered in the elongated holes.

- 26.4 Tighten screws 1.
- 26.5 **Loosen screws 4 and turn stopping lever 5 so that there is a clearance of approx. 1 mm between roller 6 and segments 2 and 3 (Fig. 26.0.2).**
- 26.6 In this position, tighten screws 4.
- 26.7 **Loosen screws 1 and adjust segment 2 so that there is a clearance of approx. 0.5 mm between the lug of segment 2 and roller 6 (Fig. 26.0.2).**
- 26.8 In this position, tighten screws 1.
- 26.9 Turn the belt pulley in its normal direction until the lug of segment 3 contacts roller 6 (Fig. 26.0.3).
- 26.10 Continue turning the belt pulley until the belt pulley is released from the drive pulley. In this position, the machine must be 1 ½ to 2 stitches before the end of cycle.
- 26.11 If it is not, proceed as follows:
- 26.11.1 Making sure the position of inner segment 2 is not changed, loosen screws 1 and position outer segment 3 farther forward or backward.
- 26.11.2 Tighten screws 1.
- 26.12 Check this adjustment (see “Correct setting”).
- Note: On control cams with several stop points, this adjustment has to be made on each segment group.
- Important: If soft de-clutching cannot be ensured by the setting specified above, the next higher size of de-clutching segments must be used.

Stock No.	Length of lug
91-132 637-15	2 mm
91-132 638-15	4 mm
91-132 432-15	8 mm
91-132 433-15	17 mm

Make preliminary adjustment of the new segments as indicated above. Making sure that the position of inner segment 2 is not changed, adjust outer segment 3 so that soft declutching is ensured.

Correct setting:

When center screw 1 is no longer positioned on the thread trapper actuating segment the upper felt 4 must be resting on felt 5 of the oil reservoir and there must be a clearance of approx. **0.3 mm** between center screw 1 and the control cam.

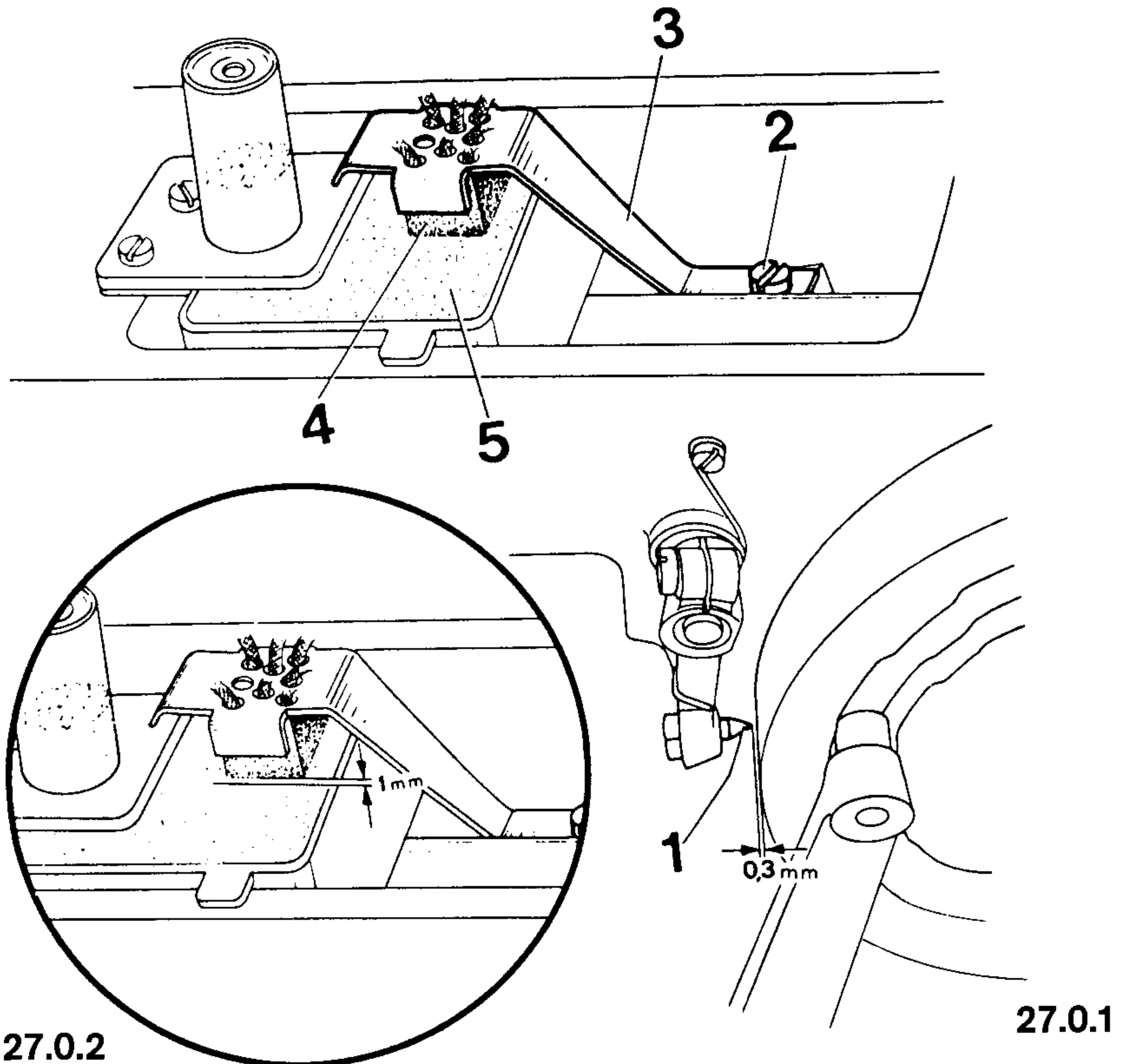

- 27.1 Remove the arm cover.
- 27.2 Disengage the stop mechanism and turn the belt pulley until center screw 1 no longer contacts the thread trapper actuating segment.
- 27.3 **Place a 0.3 mm thick feeler gauge between center screw 1 and the cam and hold it there.**
- 27.4 **Loosen screw 2 and turn bracket 3 so that upper felt 4 is resting on felt 5 of the oil reservoir.**
- 27.5 In this position, tighten screw 2.
- Note: When the center screw is resting on the thread trapper actuating segment (end-of-cycle position) there must be a clearance of approx. **1 mm** between upper felt 4 and felt 5 of the oil reservoir. If necessary, adjust the bracket accordingly.
- 27.6 Replace and screw on the arm cover.

28 Switches on machines with subcl. -966/.. and -967/..

28.1 Upper switch on machine
(on -966/08, /09, /10, /11, /13, /21, -967/01, /07, /08/, /09, /10)

Correct setting:

When stop link **3** is at the lowest point of stop cam **4** (see arrow in Fig. 28.0.2) switch **2** must just be actuated.
When the stop mechanism is engaged switch **2** must just be released.

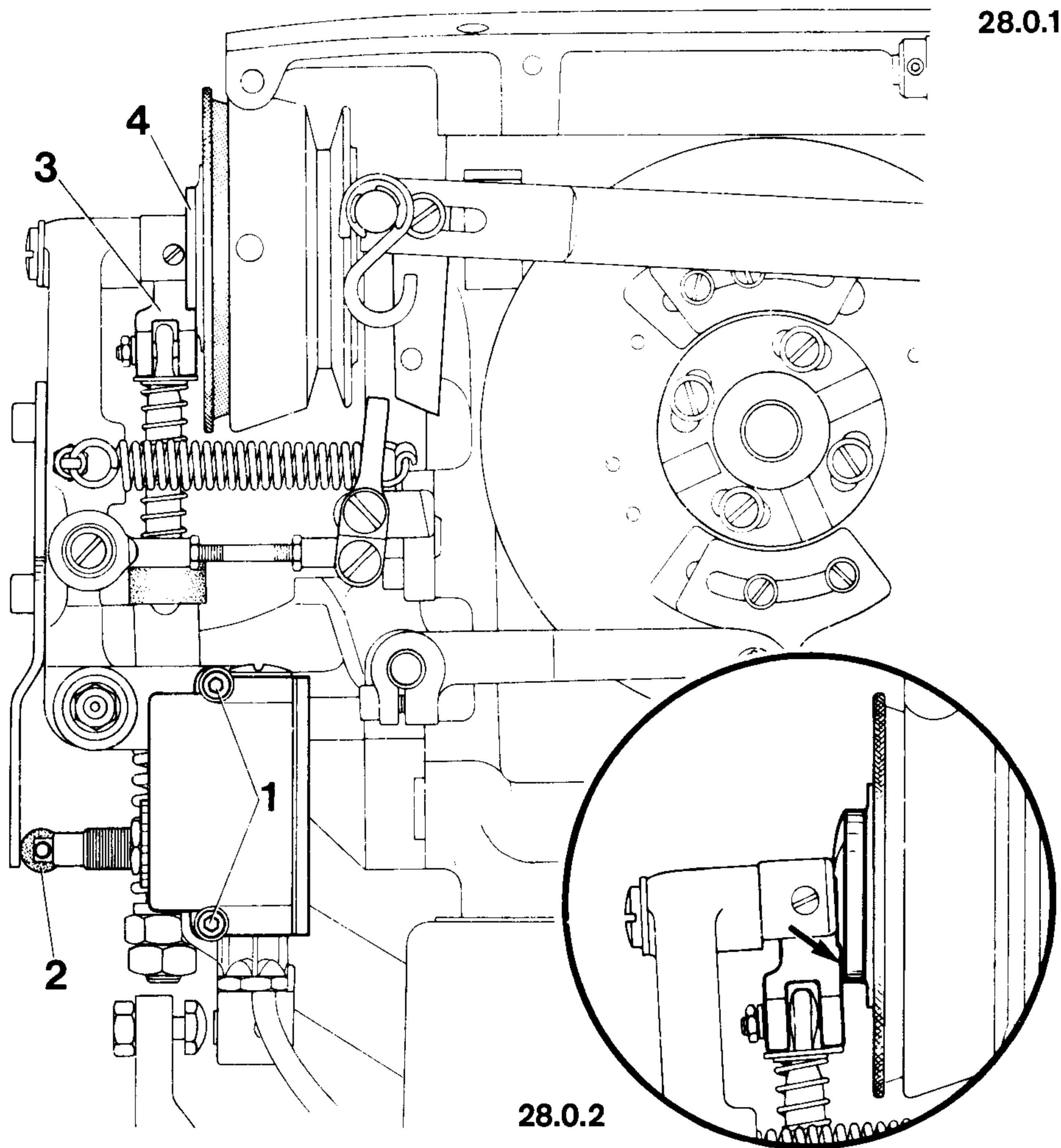

- 28.1.1 Engage stop-motion mechanism.
- 28.1.2 Loosen screws **1** and position switch **2** accordingly.
- 28.1.3 Tighten screws **1**.
- 28.1.4 Check this adjustment (see "Correct setting").

28.2 Lower switch on machine (only on -966/13)

Correct setting:

When engaging lever **7** is at rest, switch **6** must just be actuated.
When engaging lever **7** contacts thrust piece **8**, switch **6** must just be released.

- 28.2.1 Loosen screws **5** and position switch **6** accordingly.
- 28.2.2 Tighten screws **5**.
- 28.2.3 Check this adjustment (see "Correct setting").

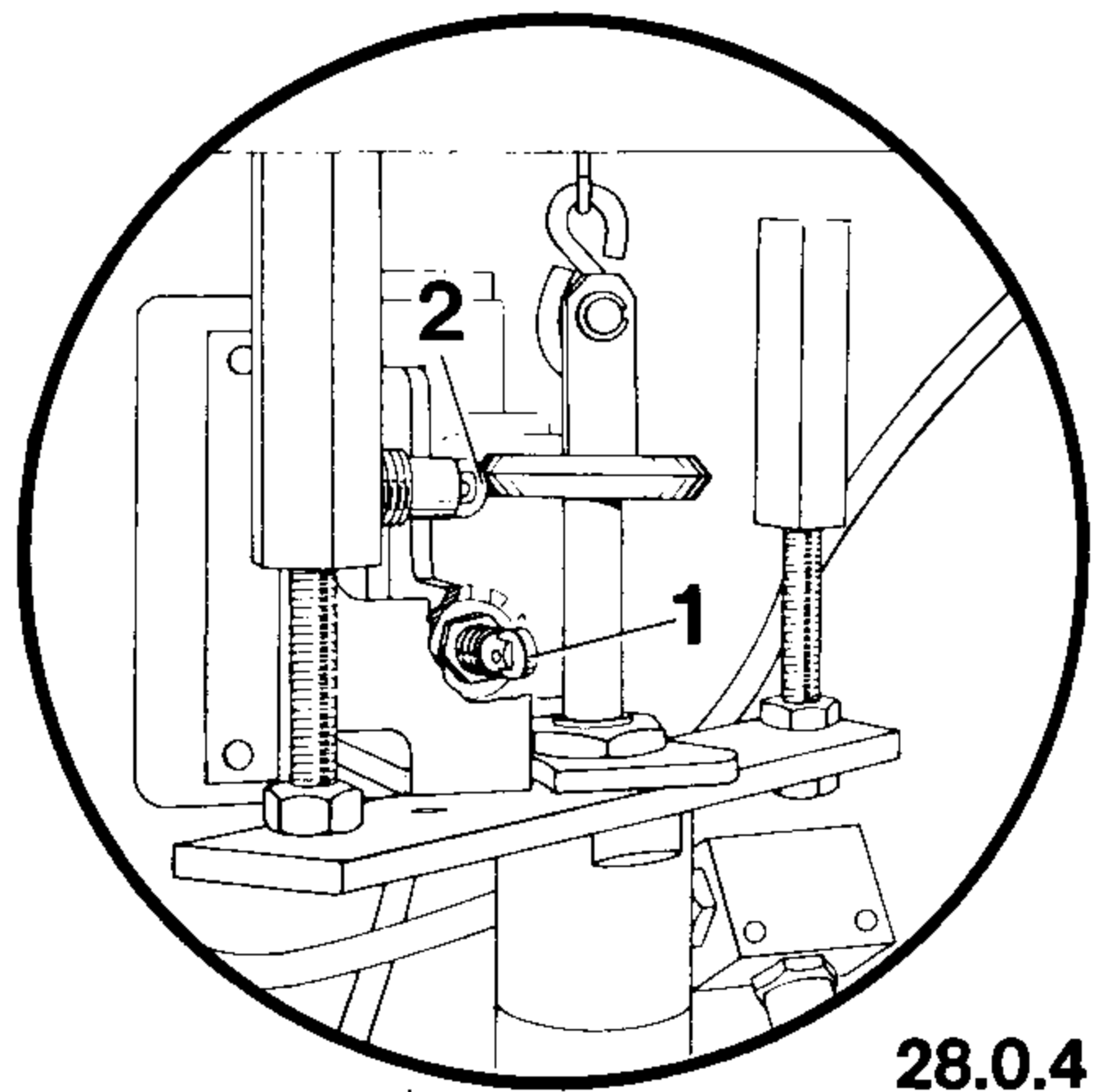
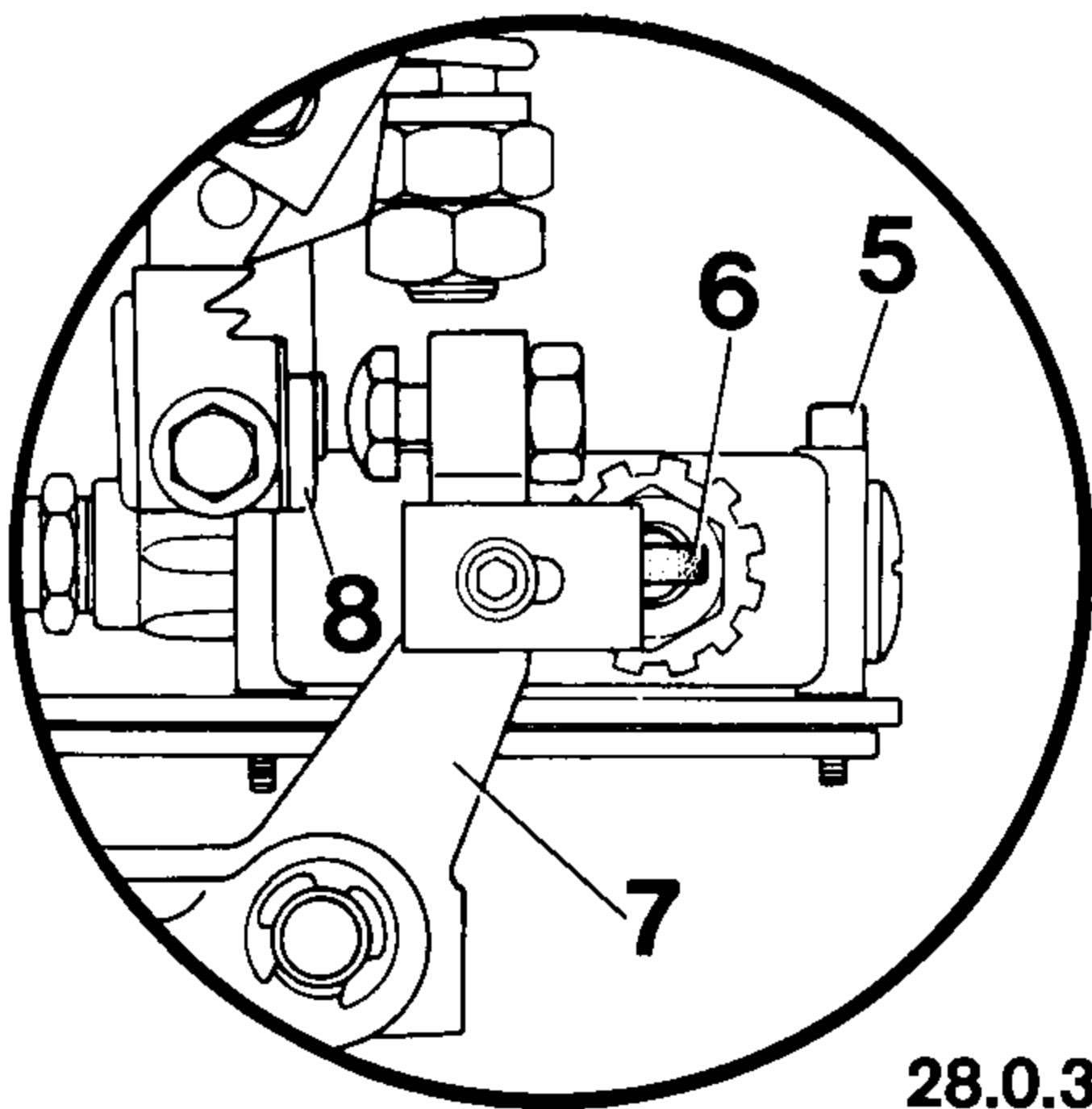

28.3 Switch below table top (on -966/08)

Correct setting:

When the lifting lever is operated, lower switch **1** must be actuated. With the lever in its resting position, upper switch **2** must be actuated.

- 28.3.1 Loosen switch retaining screws and adjust by re-positioning switches **1** and **2**.

28.4 Switch below table top (on -966/09, /10, /11, /21)

Correct setting:

When the clamping- or presser foot is resting on the needle plate, switch **9** must be actuated.

28.4.1 Loosen switch retaining screws and adjust by re-positioning switch **9**.

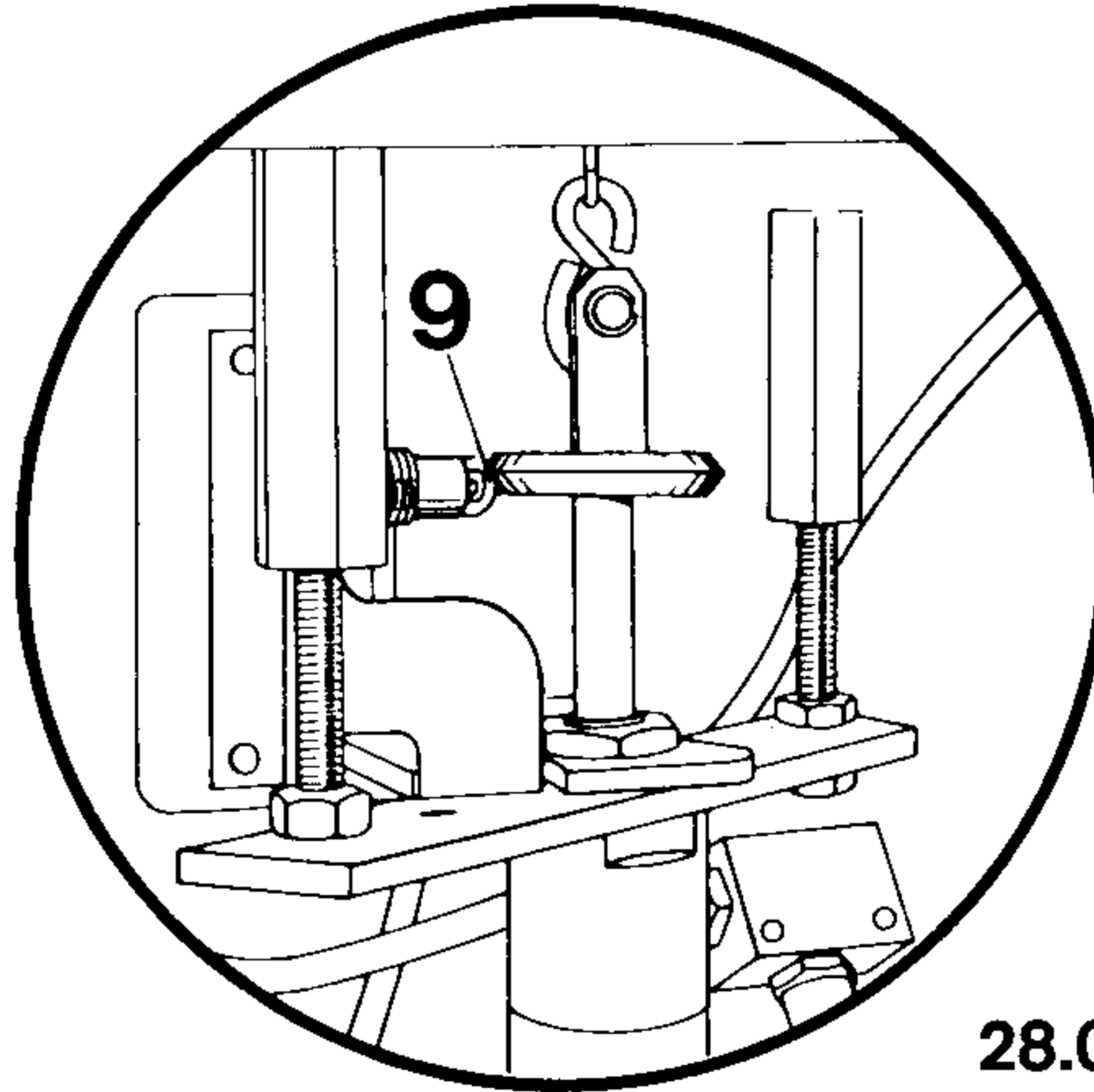

28.0.5

28.5 Switch below table top (on -967/01, /07, /08, /09, /10)

Correct setting:

When the solenoid is energized, switch **10** must be actuated.

28.5.1 Adjust by loosening the locknuts and re-positioning switch bracket **11** accordingly.

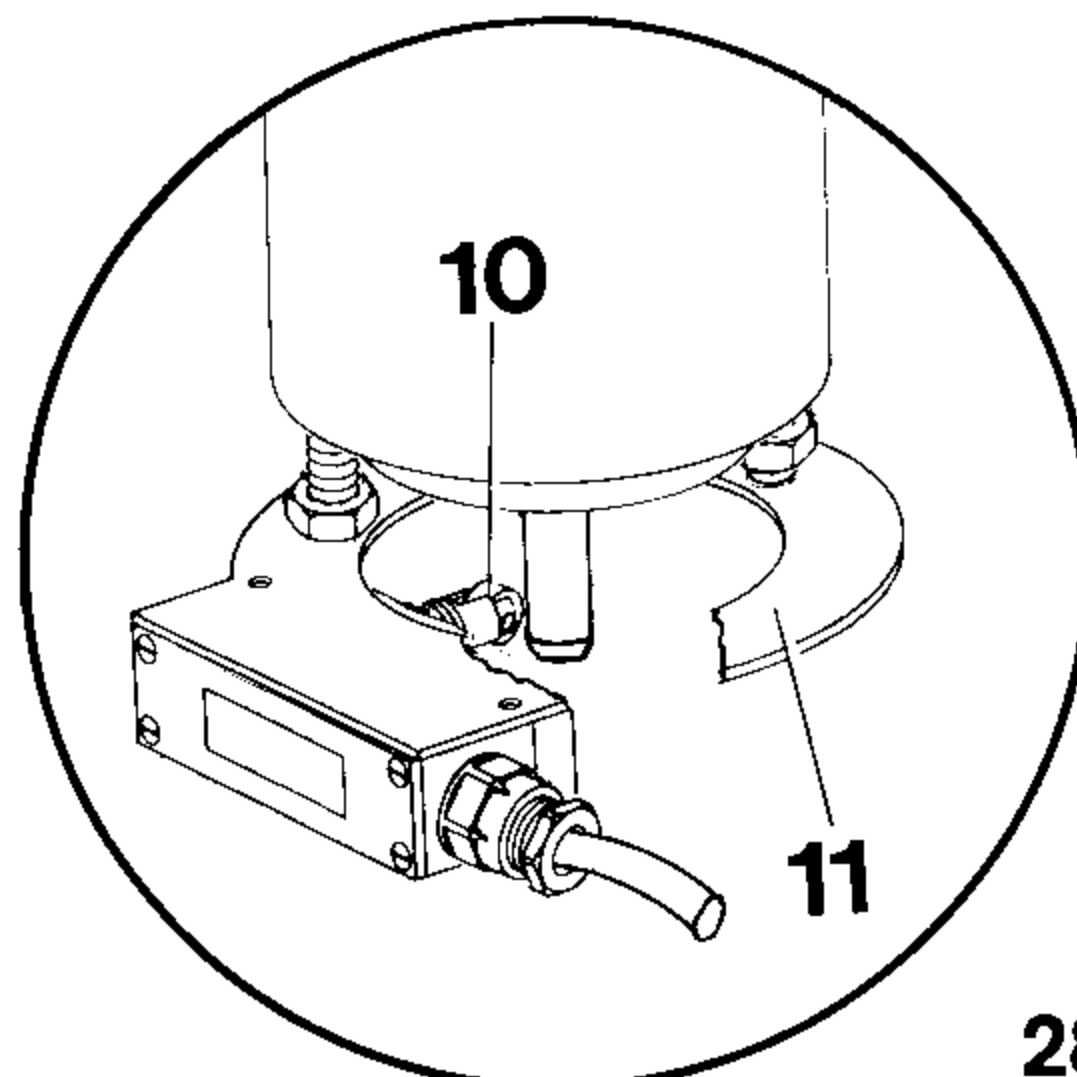

28.0.6

Correct setting:

With lifting lever **3** pushed down by approx. **10 mm** and stop link **5** at the lowest point of the stop cam (Fig. 29.0.2), locking lever **7** must contact stop **8** just lightly and clutch **9** must be released (Fig. 29.0.3).

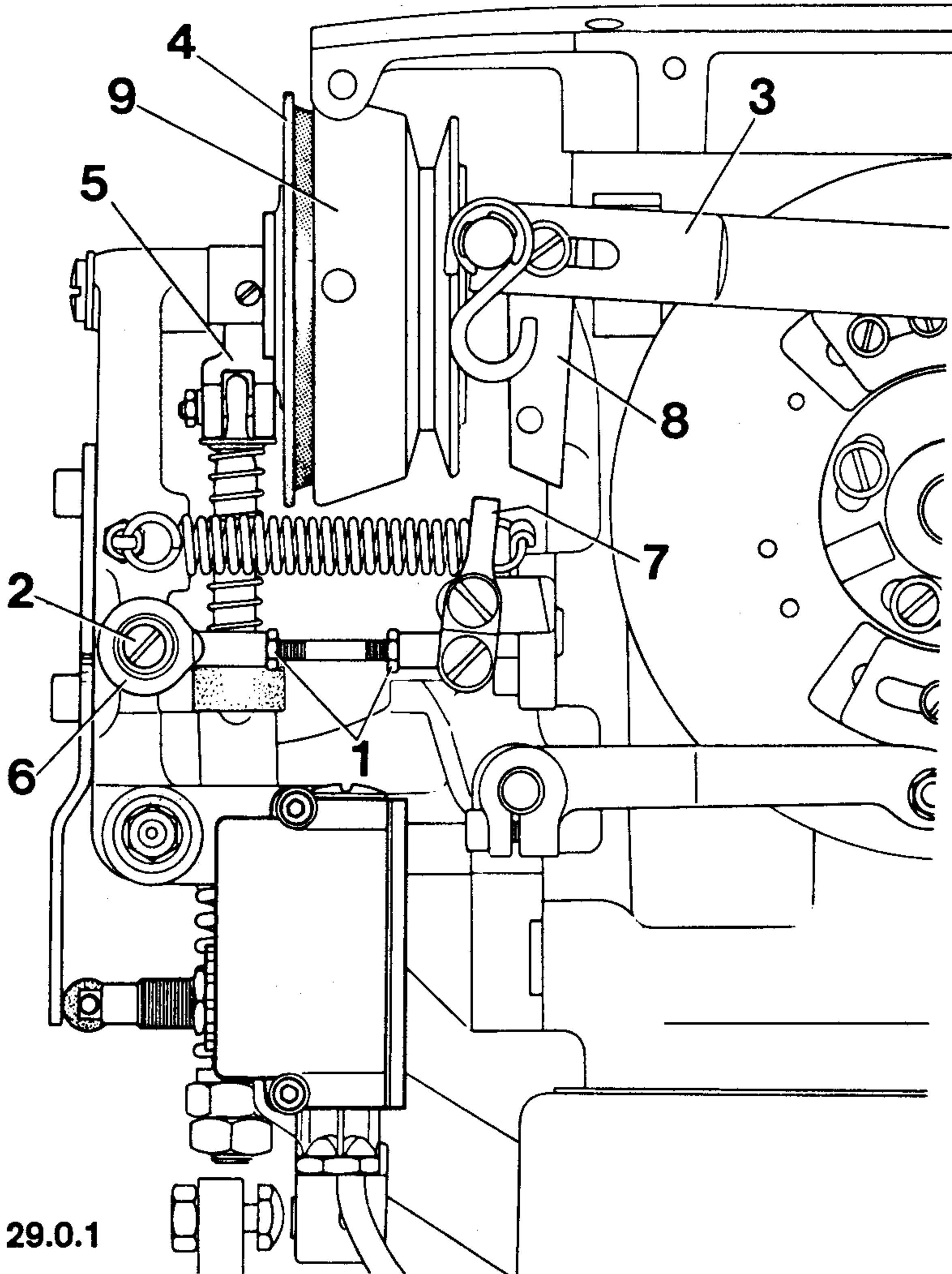

- 29.1 Making sure the stop-motion mechanism is engaged, loosen locknuts **1**.
- 29.2 Screw out screw **2**.
- 29.3 Push lifting lever **3** downwards by approx. **10 mm** and lock it in this position.

- 29.4 Pull the stop mechanism out a little and turn drive pulley 4 until the lowest point of the stop cam is positioned below stop link 5 (Fig. 29.0.2).
- 29.5 **Turn ball joint 6 until locking lever 7 contacts stop 8 just lightly (Fig. 29.0.3).**
- 29.6 In this position, screw in screw 2 and tighten it.
- 29.7 Tighten locknut 1.
- 29.8 Check this adjustment (see "Correct setting").

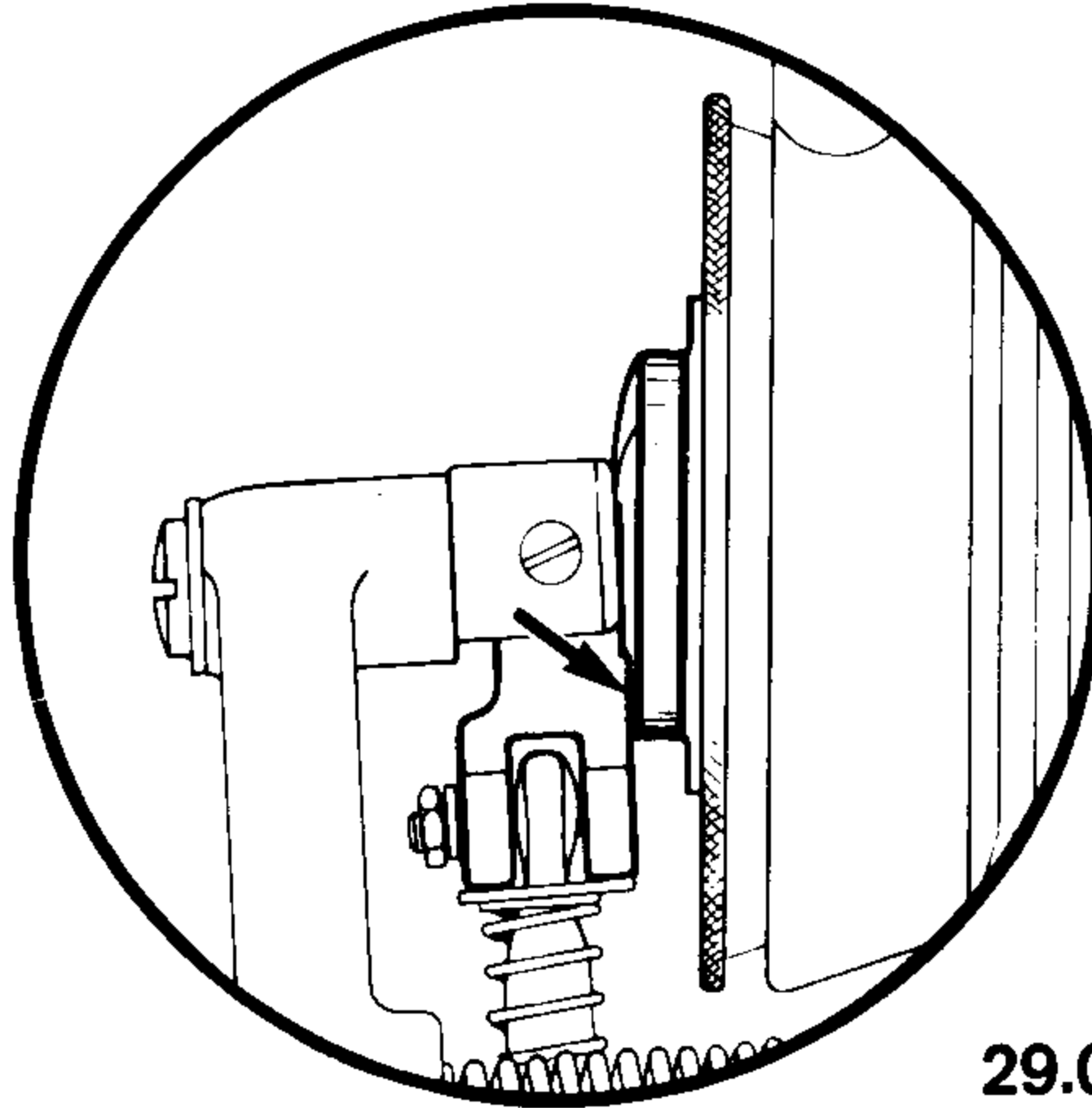

29.0.2

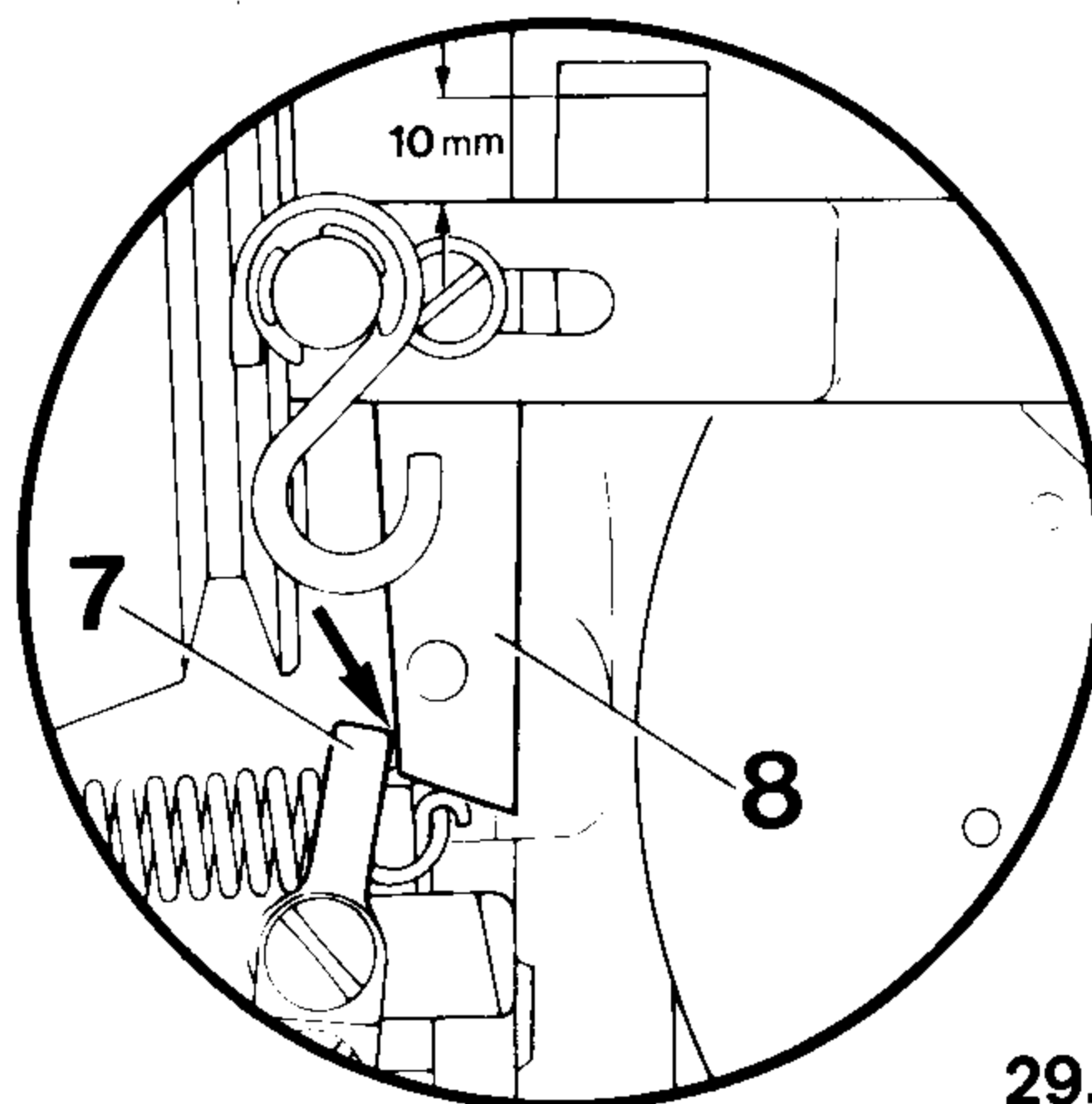

29.0.3

30 Thread puller

Correct setting:

The thread puller must be set so that reliable starting of the sewing action is ensured, but that, on the other hand, no thread ends protrude from the workpiece.

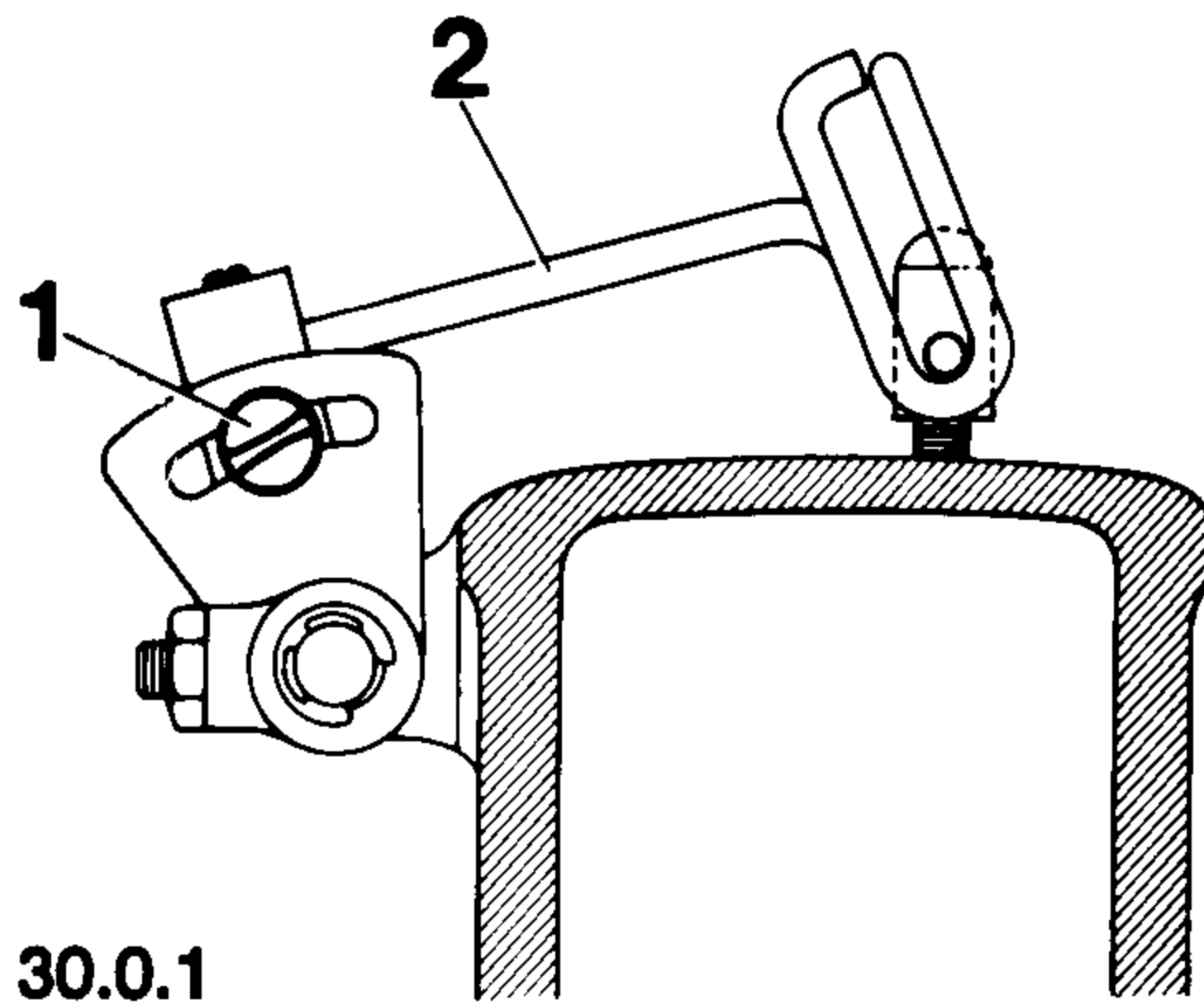

30.0.1

- 30.1 Thread the machine, place a piece of fabric under the button clamp and sew on a button.
- 30.2 Check the machine setting (see "Correct setting").
- 30.3 Loosen milled screw 1.
- 30.4 Turn thread puller 2 up or down, as follows:
Down for **less** starting thread.
Up for **more** starting thread.
- 30.5 Tighten milled screw 1.
- 30.6 Replace the two side covers and secure them in position with three screws each, fit the rear belt guard and swing in the eye guard.

Deviating adjustments on machines with subclass 9/..

31 Clamp position lengthwise to the arm

Correct setting:

Both in the front and rear position of the stem clamp there must be a clearance of **0.2 mm** between the needle shank and the inside of the clamp.

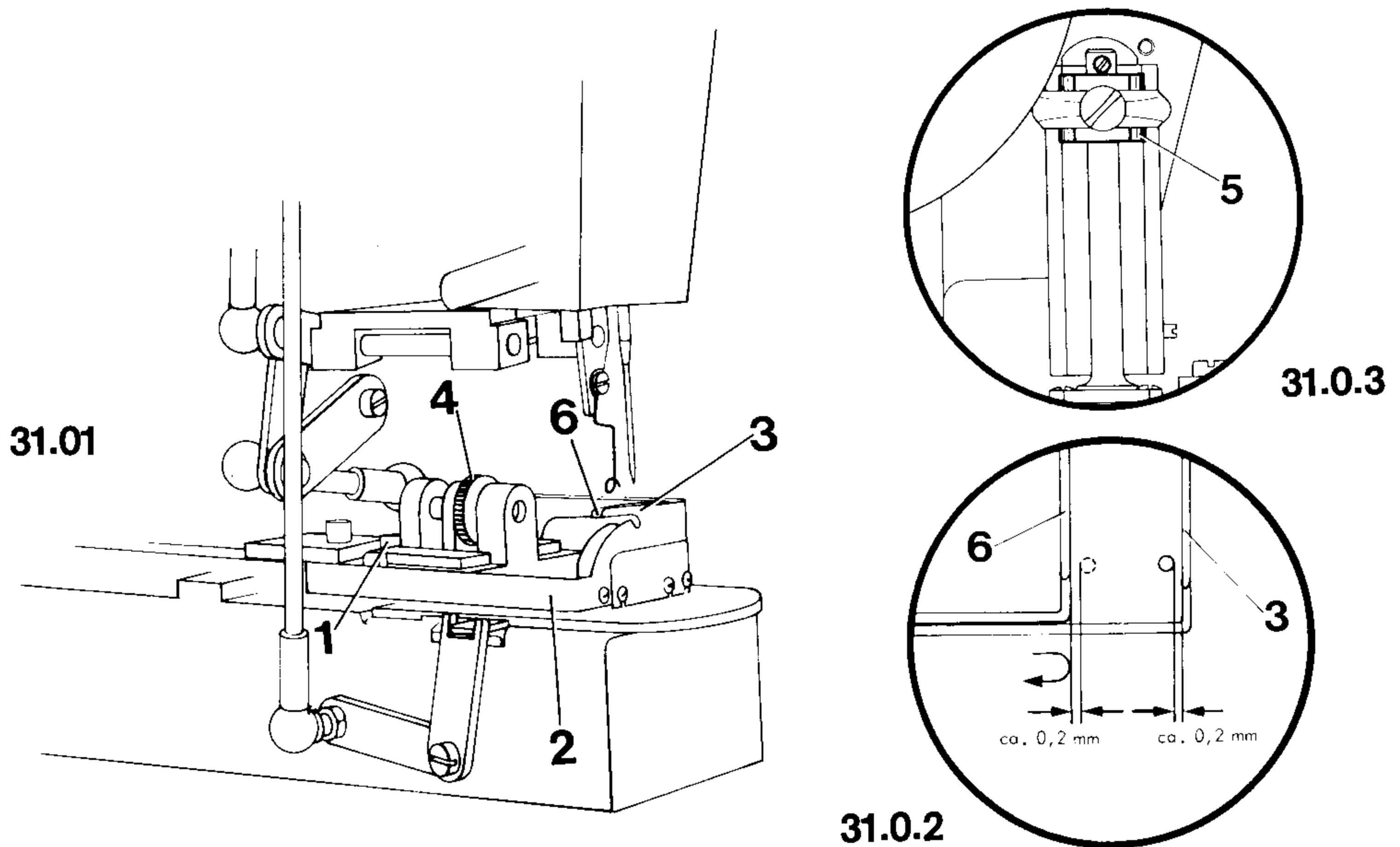

- 31.1 Swing out the stop-motion mechanism by hand and turn the V-belt pulley to set the needle bar at bottom dead center.
- 31.2 **Loosen screw 1 and position stem clamp 2 so that there is a clearance of 0.2 mm between the shank of the needle and the inside of fixed part 3.**
- 31.3 In this position, tighten screw 1.
- 31.4 Place a sewn-on button in stem clamp 2 and slightly tauten the stem by turning regulating screw 4.
- 31.5 Remove the button from the stem clamp.
- 31.6 Set the feed stroke of the stem clamp (for stem length) lengthwise to the arm by positioning retaining bracket 5 as follows:
downwards = longer stroke
upwards = shorter stroke
- When positioning the retaining bracket ensure that there is a clearance of 0.2 mm between the inside of part 6 and the shank of the needle when the stem clamp is in its front position.**
- 31.7 Turn the V-belt pulley in sewing-direction and carry out a check.
- 31.8 Correct, if necessary at retaining bracket 5 and check again.
- 31.9 If the clearance of 0.2 mm is not obtained, correct this at roller lever 4 (as described in section 5).

32 Clamp position crosswise to the arm

Correct setting:

The first four stitches must be located in the threads of the sewn-on button.

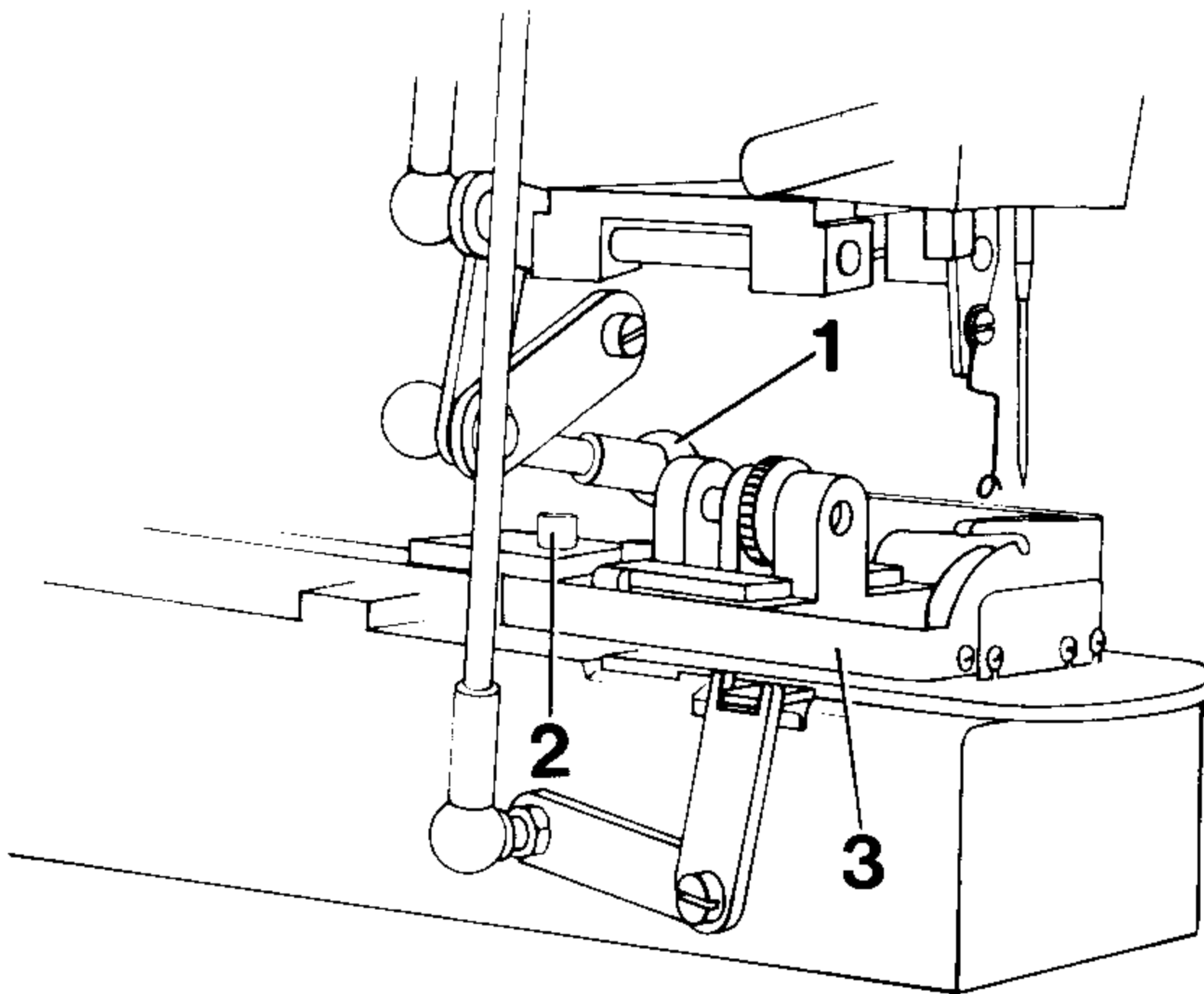

32.0.1

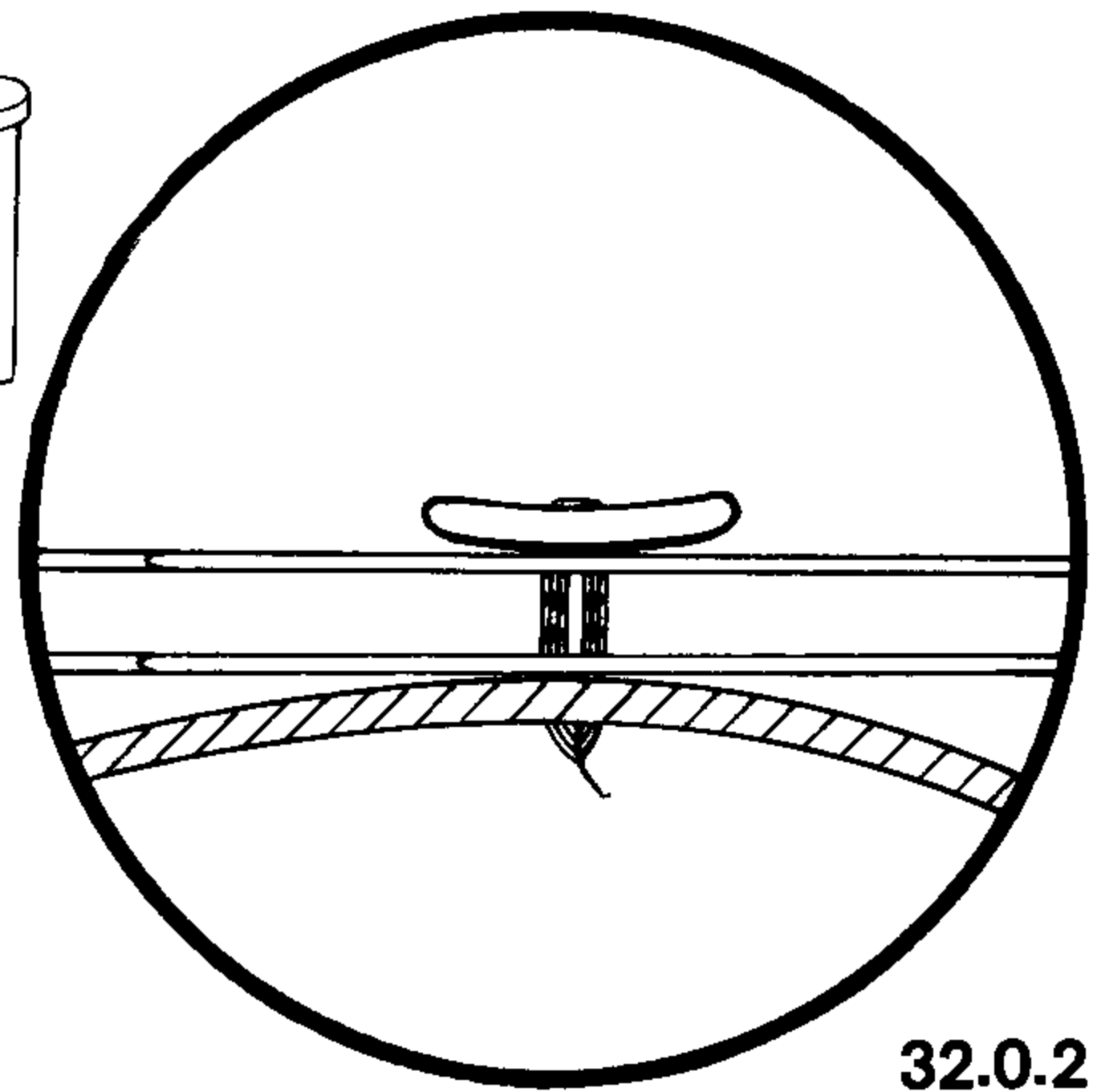

32.0.2

- 32.1 Disconnect ball joint 1 and loosen screw 2 a little.
- 32.2 **Position clamp 3 laterally in such a way that the first four stitches are sewn in the threads of the sewn-on button.**
- 32.3 Tighten screw 2 and re-connect ball joint.
- 32.4 Place in a sewn-on button and test the stem wrapping function.
- 32.5 Carry out a check (see "Correct setting").

33

Thread trimmer knife

Correct setting:

With the machine in its resting position the outer angled surface of knife 5 must be roughly flush with the outer surfaces of clamp 4.

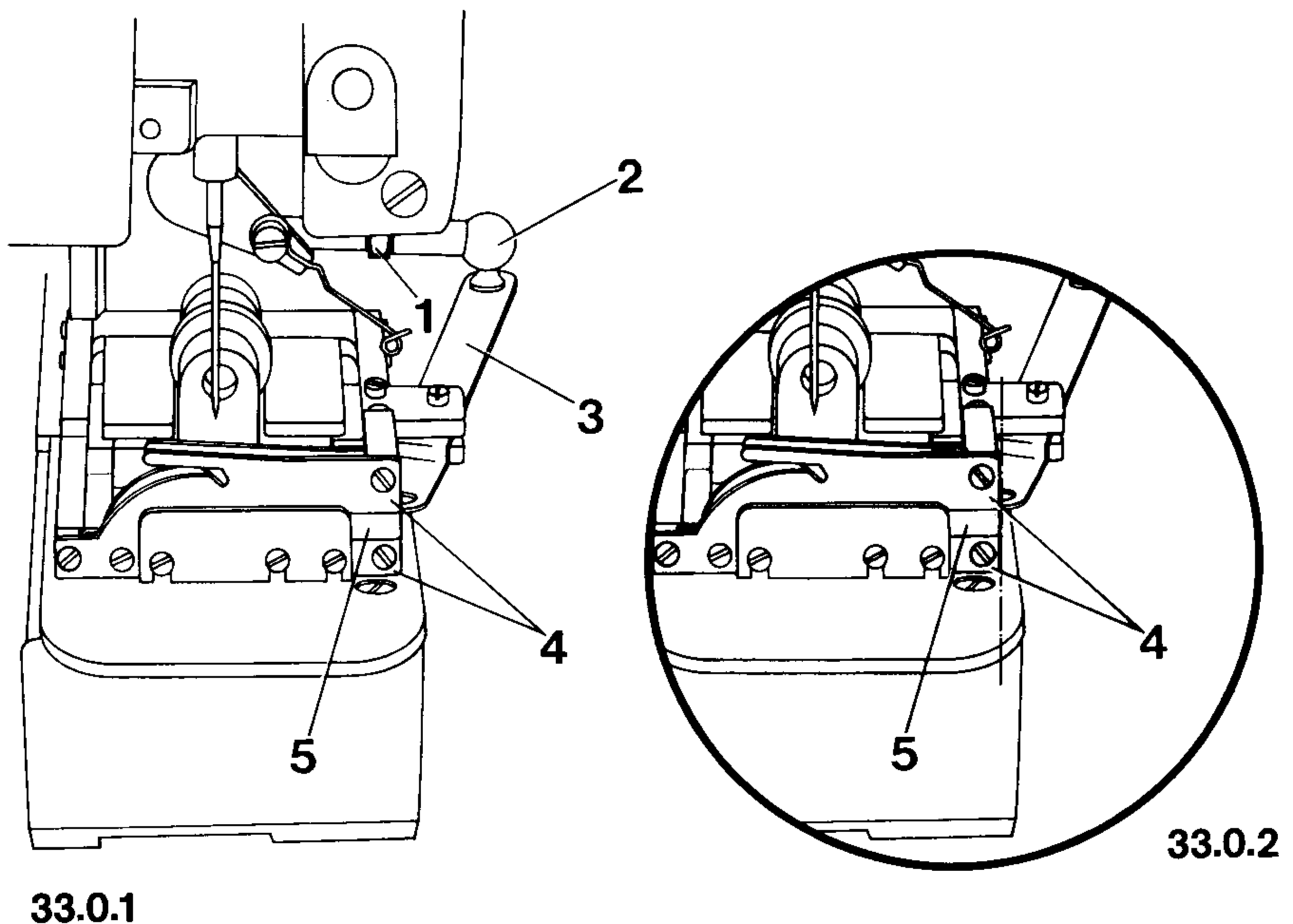

- 33.1 Loosen locknut 1 and disconnect ball joint 2.
- 33.2 Swing lever 3 outwards as far as it will go, then push it back in by about 1 mm.
- 33.3 **Retain this position, turn ball joint 2 accordingly and re-connect it (outer angled surface of knife 5 is roughly flush with the outer surfaces of clamp 4).**
- 33.4 Tighten locknut 1.

Correct setting:

When the spreader is in its resting position and the blind looper is at its far left position there must be a clearance of **0.5 mm** between the spreader point and the rear edge of the blind looper. Also, when the spreader is in its front and rear position, there must be a slight play between the spreader and the cutout in lever **5**.

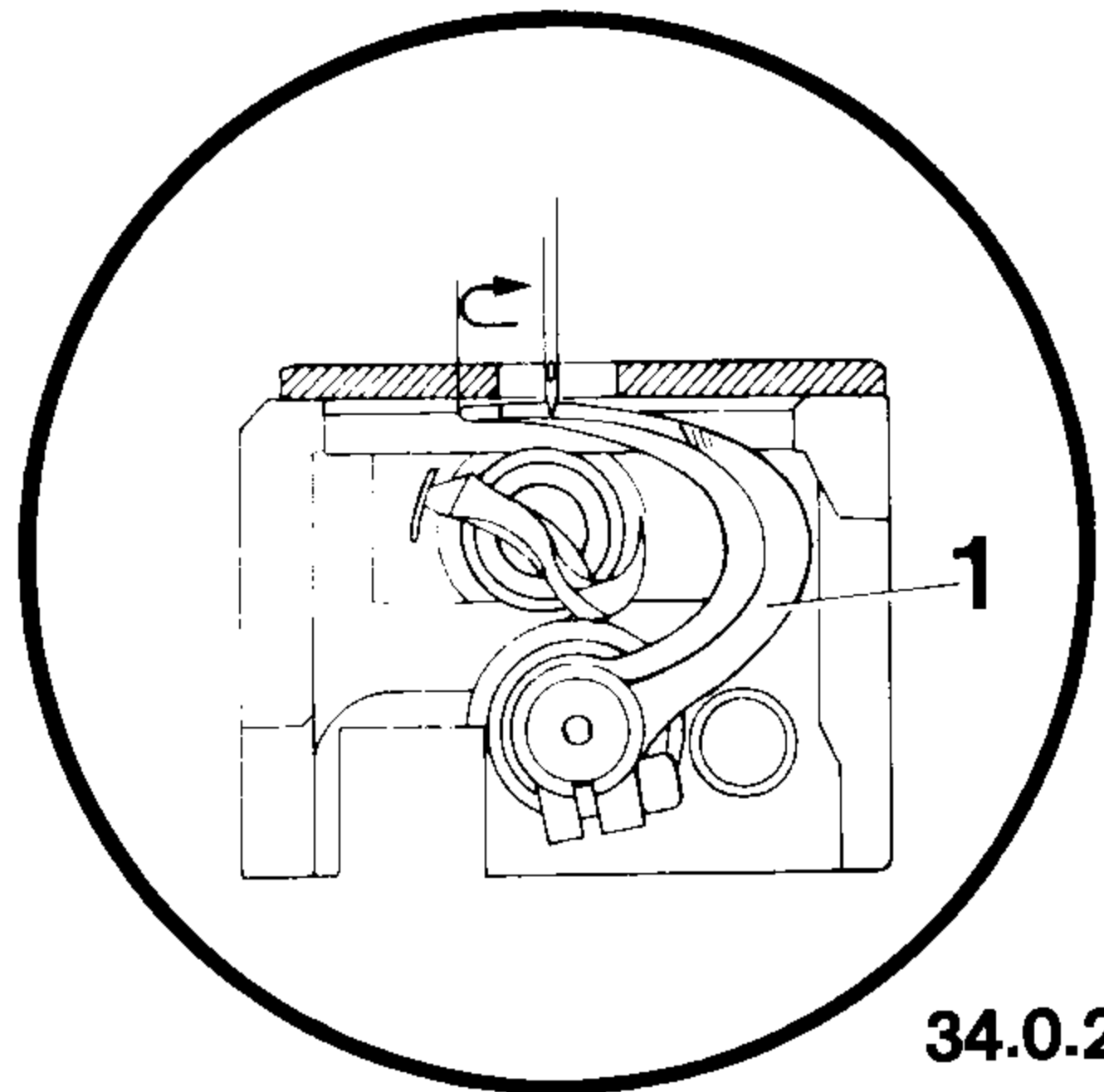

34.0.2

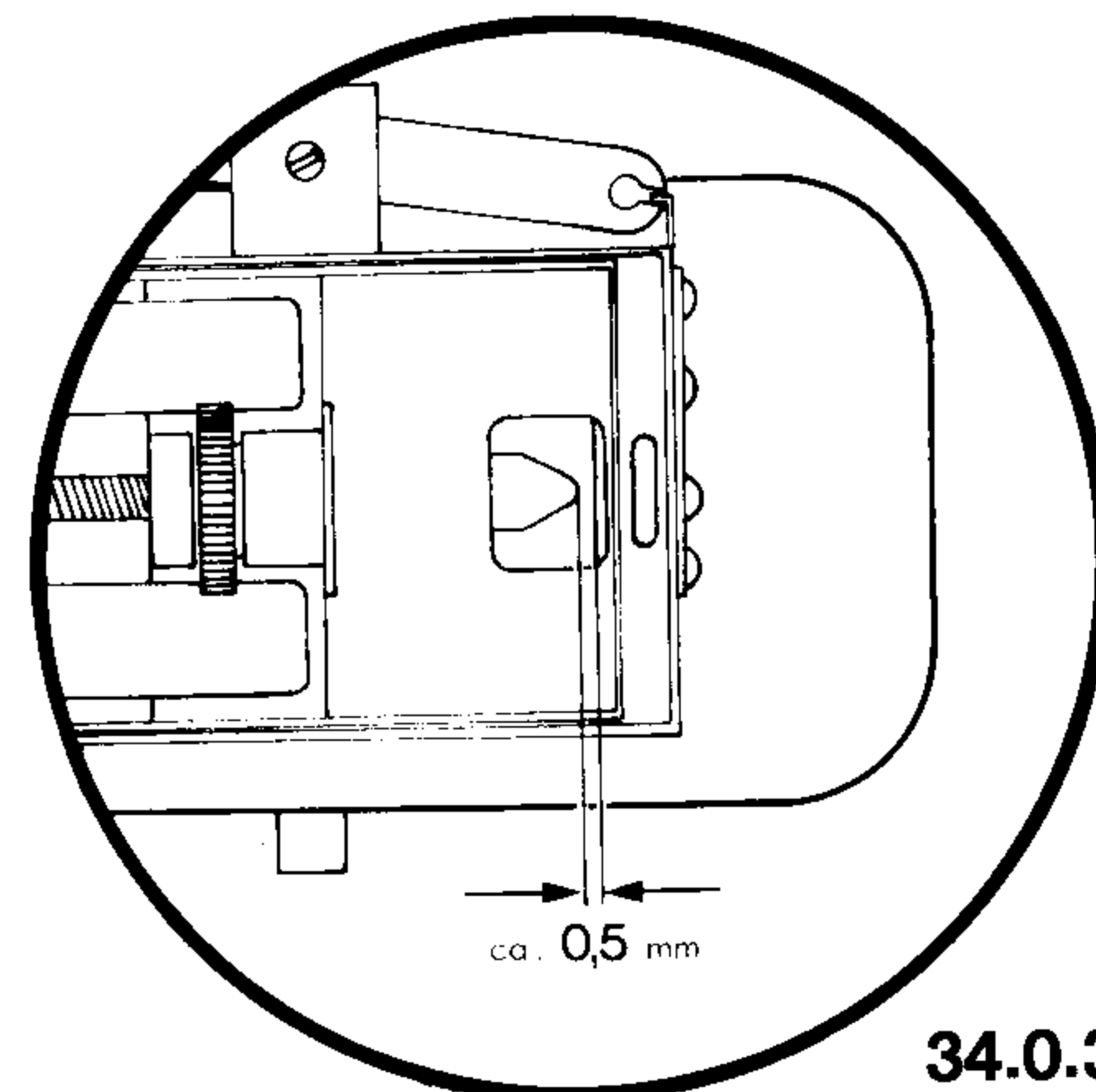

34.0.3

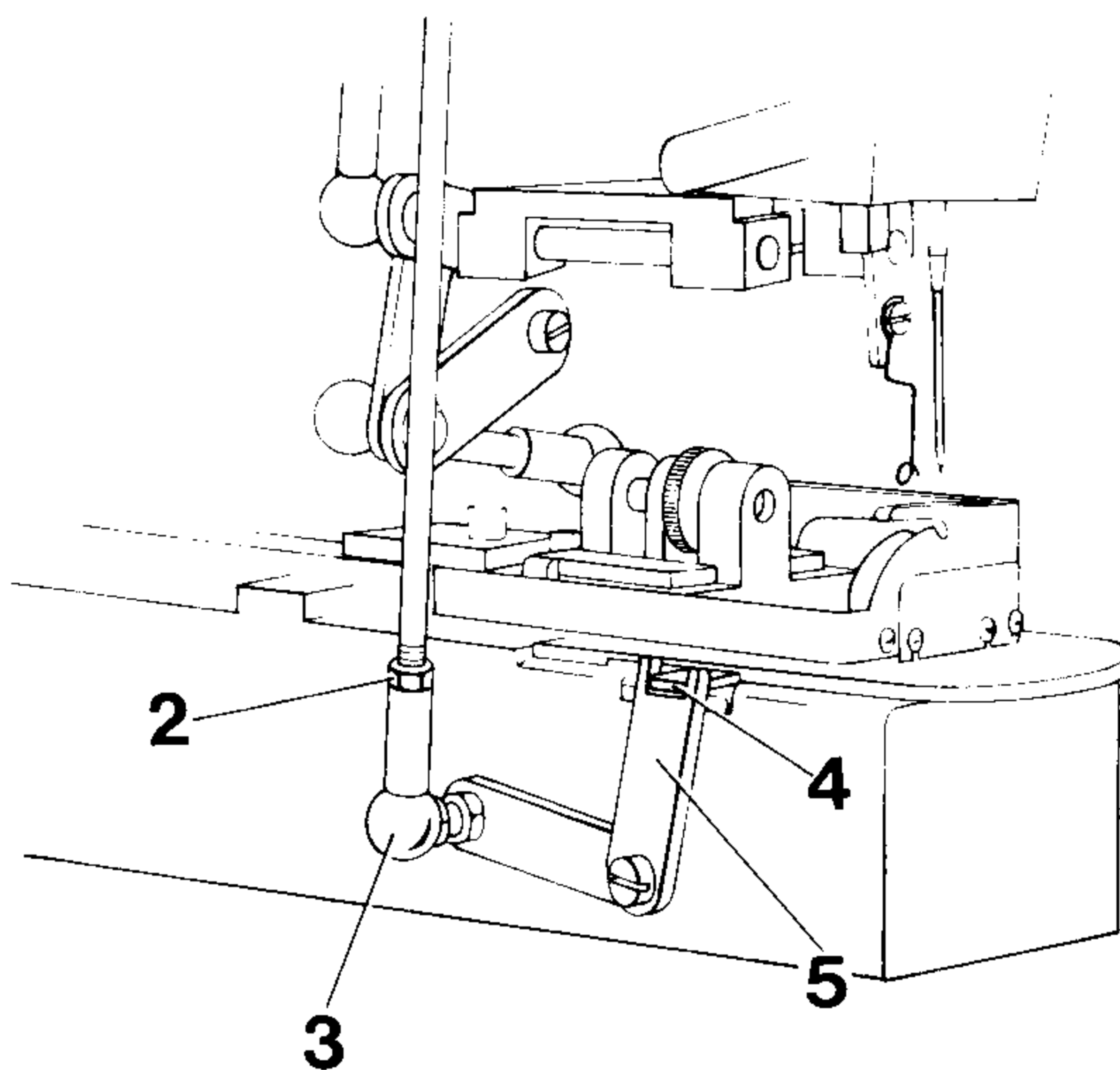

34.0.1

- 34.1 Disengage the stop-motion mechanism by hand and turn the V-belt pulley in sewing direction so that blind looper 1 is in its far left position.
- 34.2 Loosen locknut 2 and disconnect ball joint 3.
- 34.3 **Turn ball joint 3 so that there is a clearance of 0.5 mm between the point of spreader 4 and the rear edge of blind looper 1 when ball joint 3 is re-connected, and the spreader has a slight play in the cutout of lever 5 in its front and rear position.**
- 34.4 Re-connect ball joint 3 and tighten locknut 2.
- 34.5 Set the machine at the end of its cycle and carry out a check (see "Correct setting").

Correct setting:

The spreader must enter the center of the thread triangle (see arrow in Fig. 35.0.2).

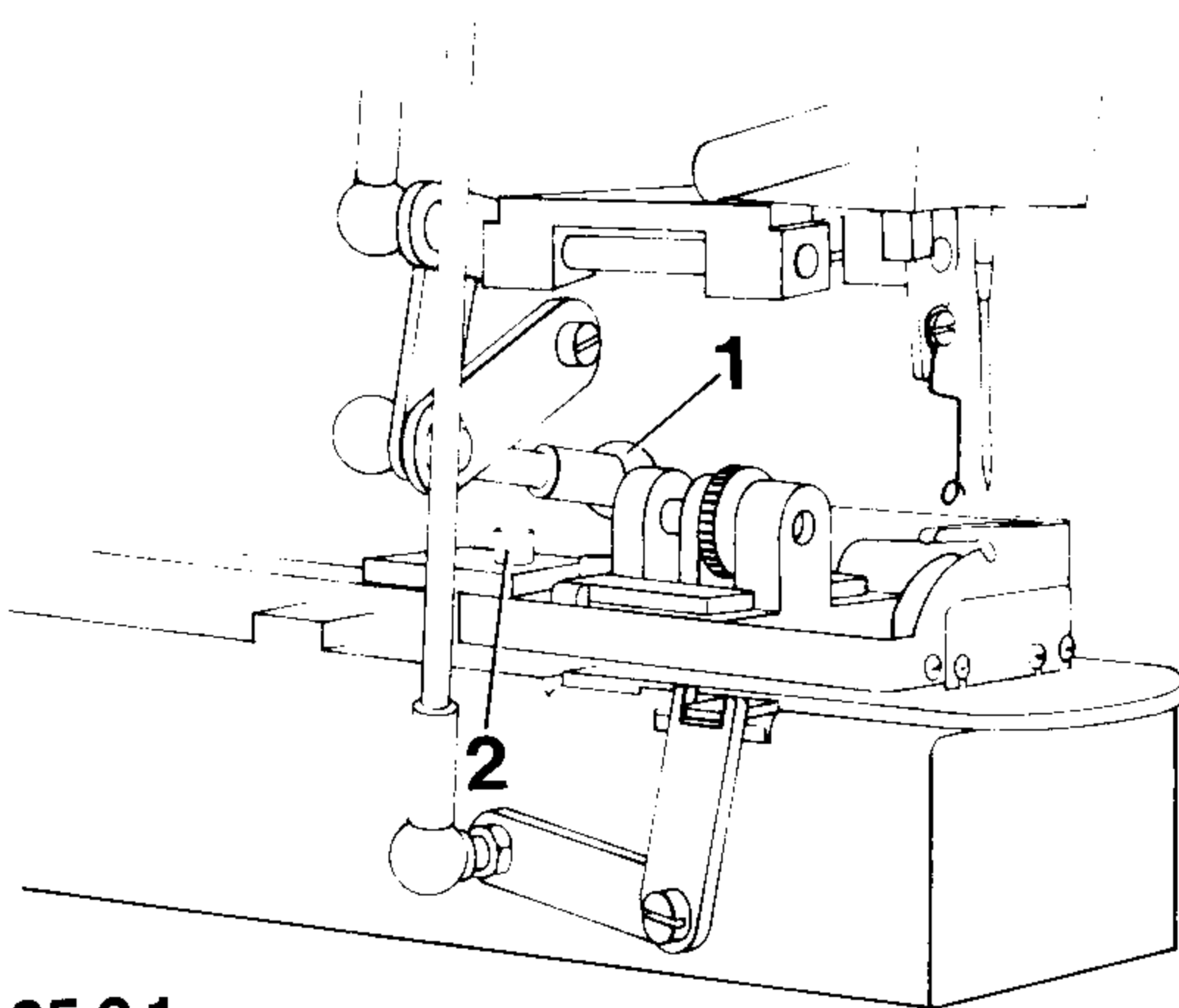

35.0.1

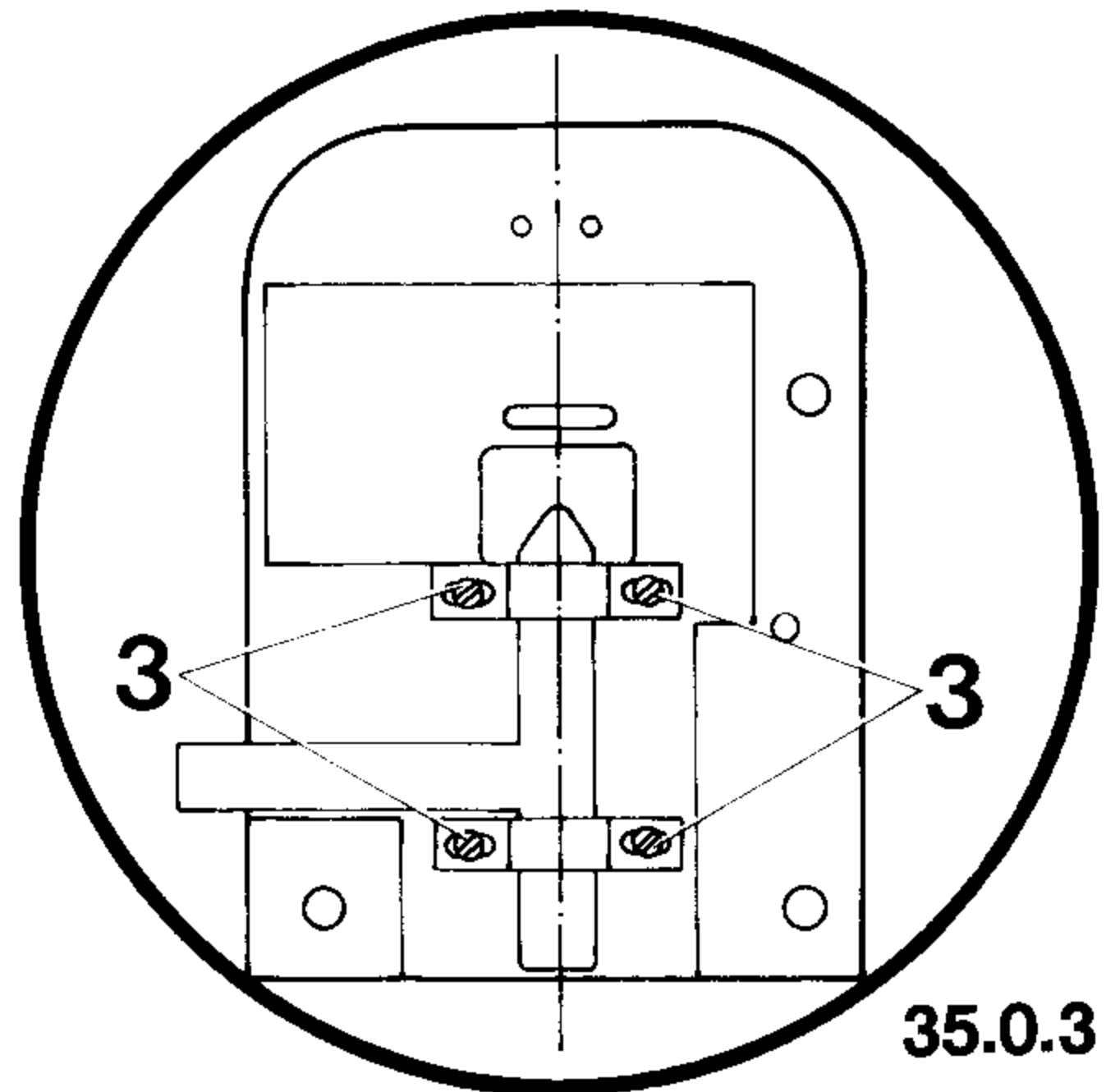

35.0.3

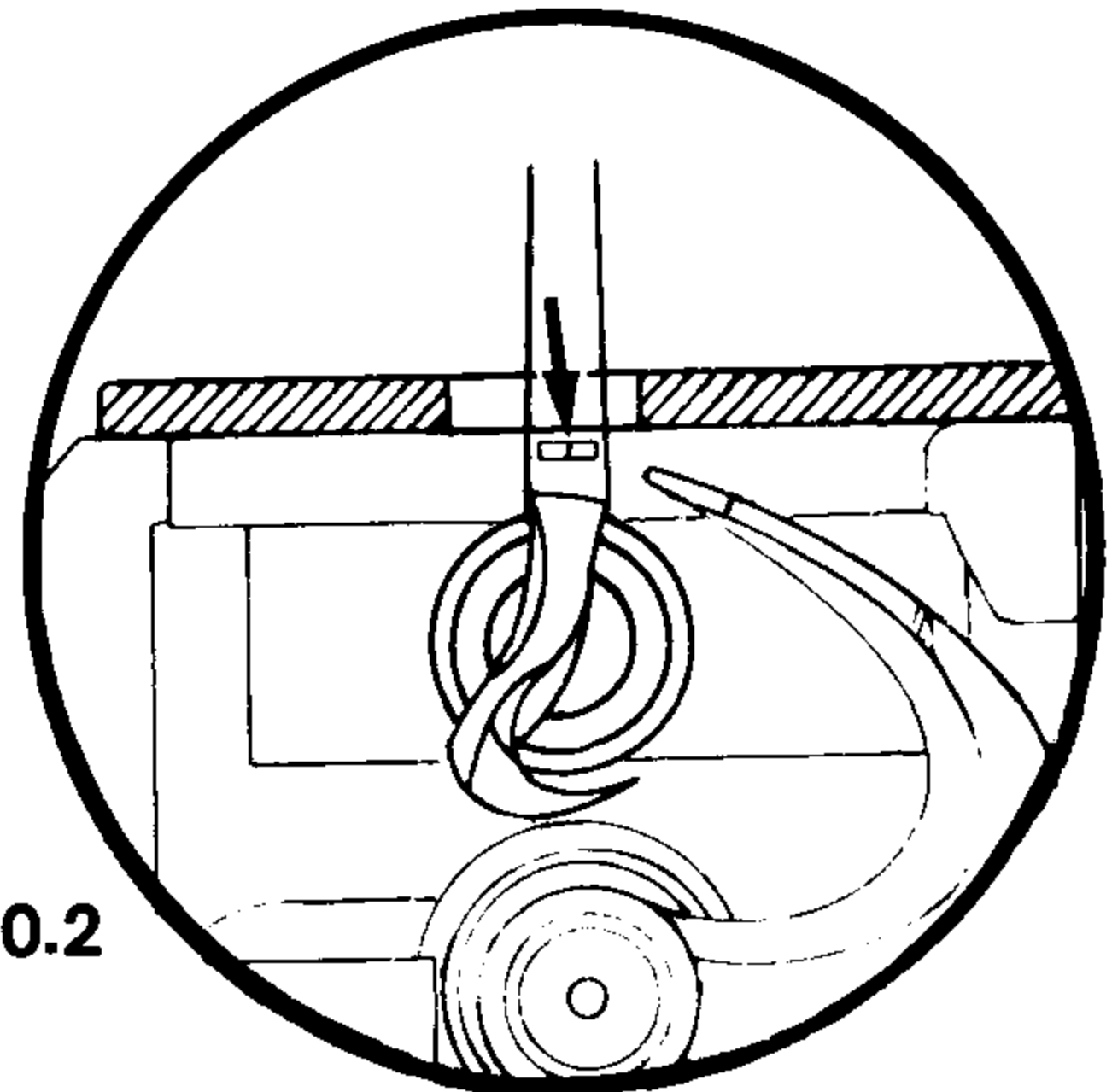

35.0.2

- 35.1 Thread the machine and wrap a button stem.
- 35.2 Turn off the master switch shortly before the end of the machine cycle and turn the V-belt pulley in sewing direction until the stop-motion mechanism engages.
- 35.3 Fully lower the presser bar lifter and check that the spreader enters the center of the thread triangle (see arrow in Fig. 35.0.2).
- 35.4 If correction is necessary, proceed as follows:
- 35.5 Disconnect ball joint 1, remove screw 2 and remove the stem clamp.
- 35.6 Remove the needle plate and re-position the spreader guide on the underside of the needle plate accordingly after loosening screw 3.
- 35.7 Making sure that the spreader can move freely, tighten screws 3 and re-fit the needle plate.
- 35.8 Re-fit the stem clamp with screw 2 and adjust it according to section "2".
- 35.9 Re-connect ball joint 1 and carry out a check (see "Correct setting").

Correct setting:

When the lifting lever is operated, thread wiper 3 must pass behind the needle as close as possible and on its return stroke reliably catch the thread with its eye.

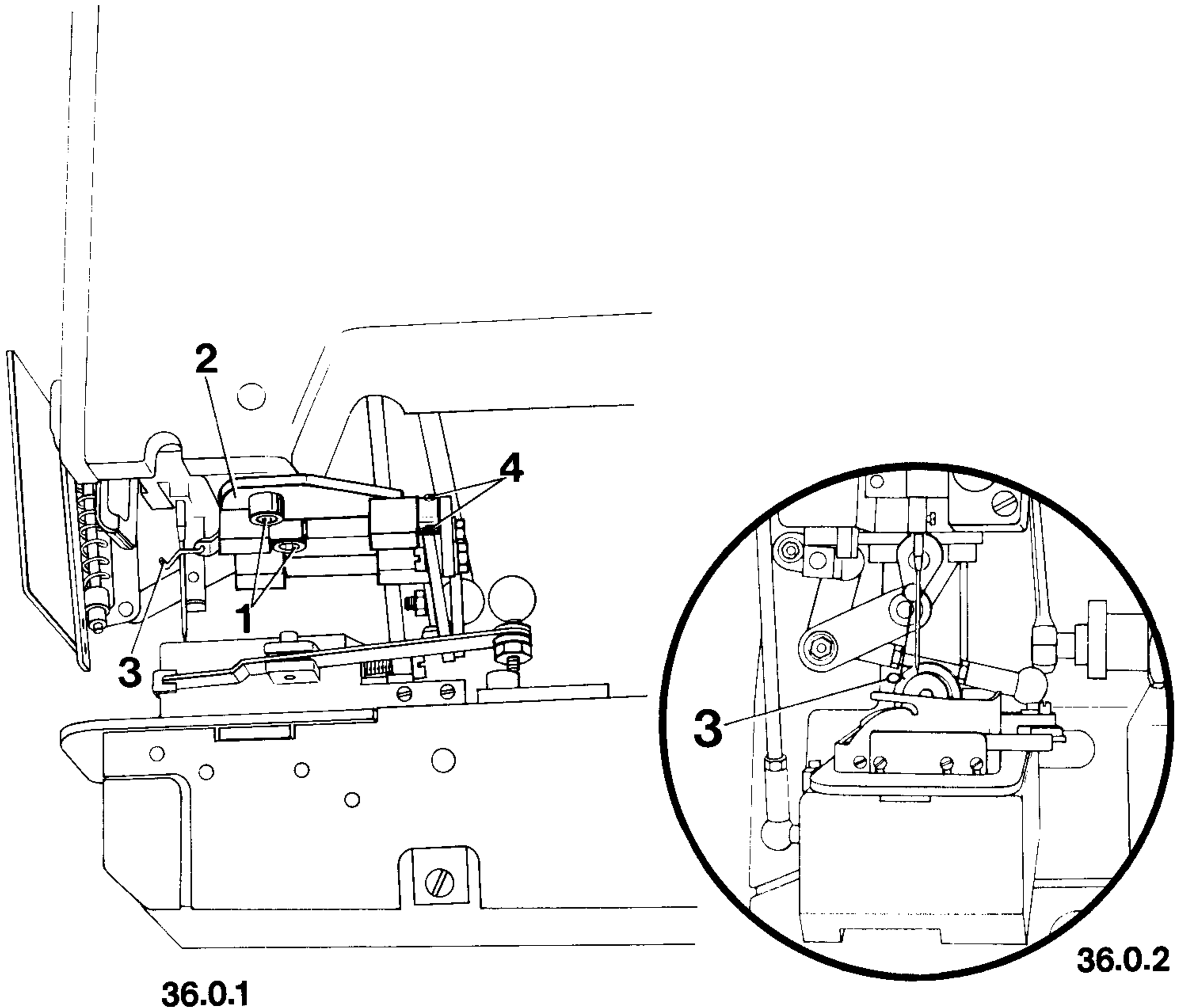

36.0.1

36.0.2

- 36.1 **Loosen allen screws 1 and position plate 2 lengthwise to the arm so that when the lifting lever is operated thread wiper 3 passes as close as possible behind the needle.**
- 36.2 Loosen screws 4 a little.
- 36.3 Set thread wiper 3 in its far left position by operating the lifting lever.
- 36.4 **In this position turn the thread wiper so that on its return stroke it catches the thread reliably with its eye.**
- 36.5 Tighten screws 4 and carry out a check (see "Correct setting").

Deviating adjustments on machines with subclass 9/..

37 Shank guiding plate

Correct setting:

The button shanks must readily enter the shank guide when light pressure is applied.

37.0.1

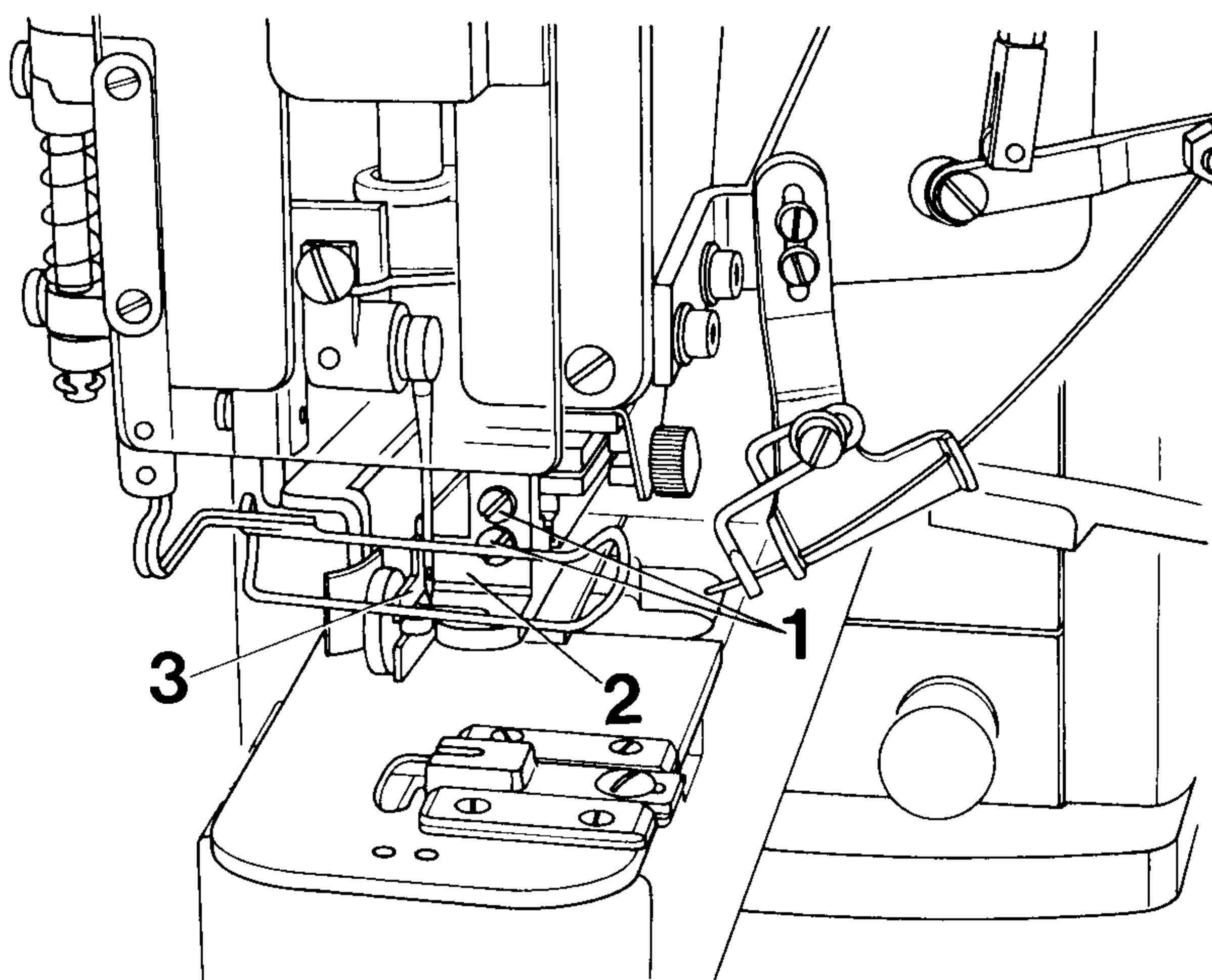

37.1 Loosen screws **1**.

37.2 **Re-position guide 2 vertically in accordance with “Correct setting”.**

37.3 Tighten screws **1**, making sure retaining clamp **3** of the guide plate is vertical.

38 Button clamp (lengthwise to the arm)

Correct setting:

The needle must enter in the middle of the button-shank eyelet, as viewed lengthwise to the arm.

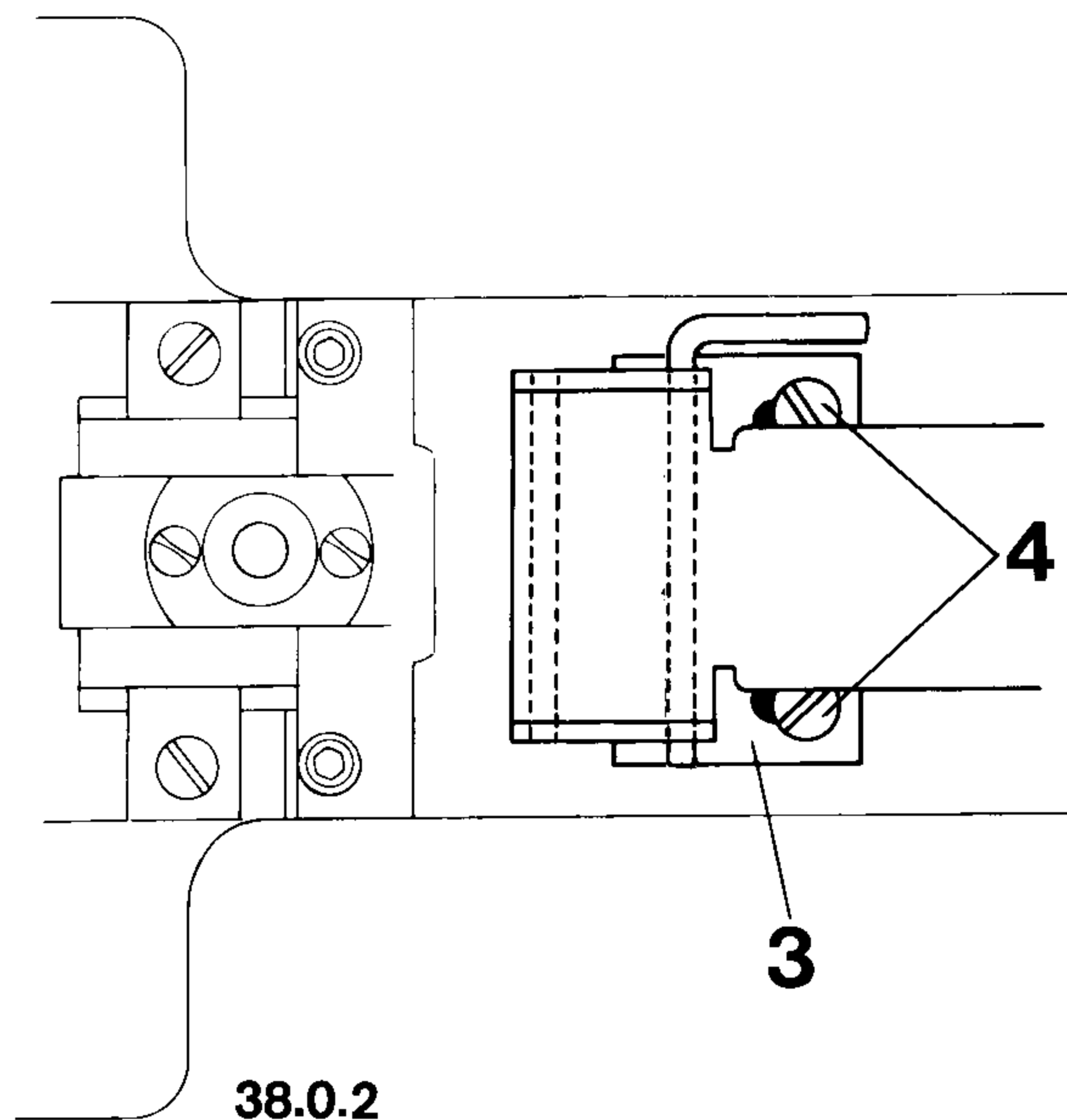
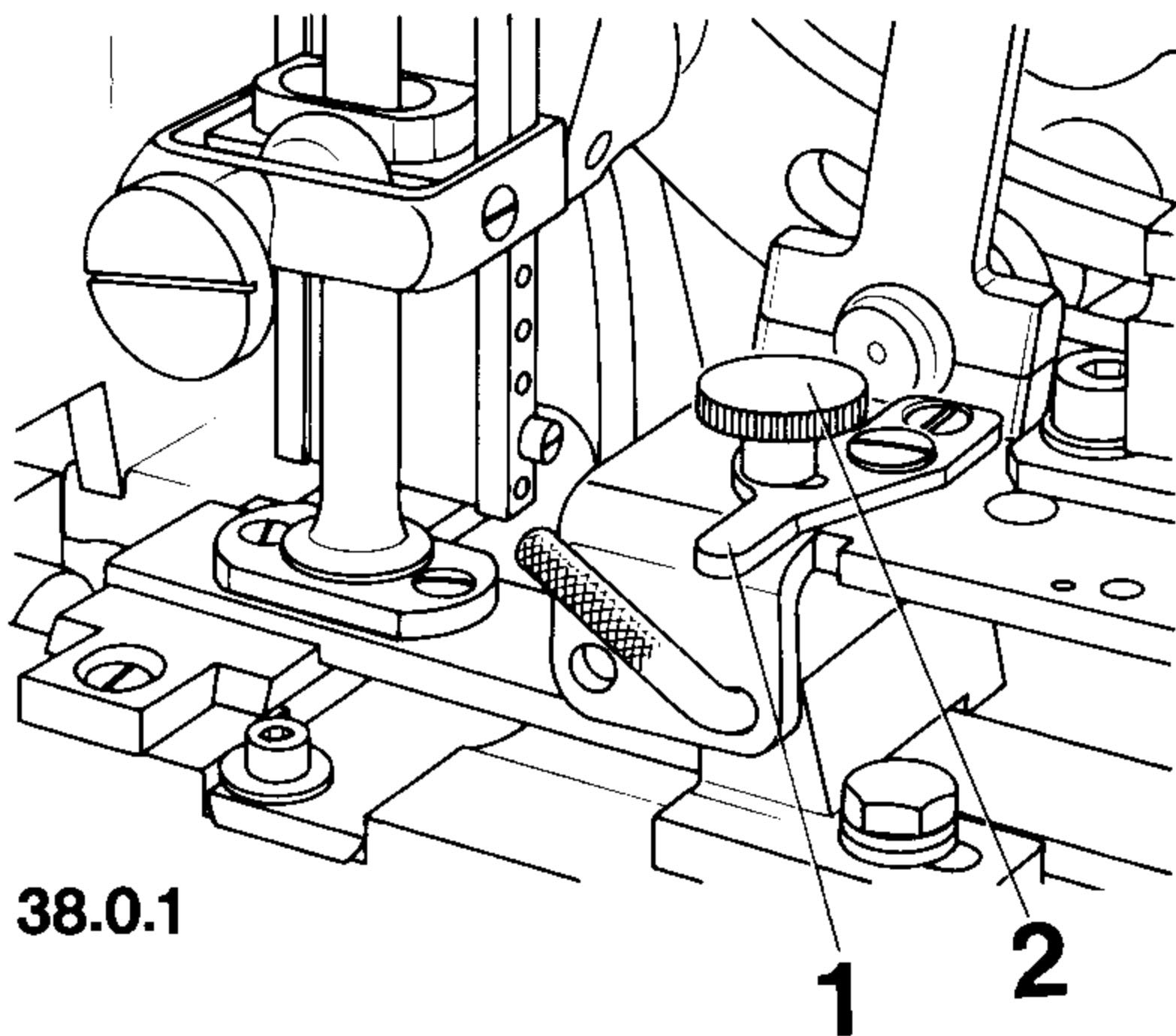

38.1 **Adjust the position of the button-shank eyelet in relation to the needle at lever 1 (screw 2) according to “Correct setting”.**

38.2 If necessary, re-position bearing bracket 3 (screws 4) according to “Correct setting”.

39

Button clamp (crosswise to the arm)

Correct setting:

At the right and left of its throw the needle penetration points must be the same distance from the button shank.

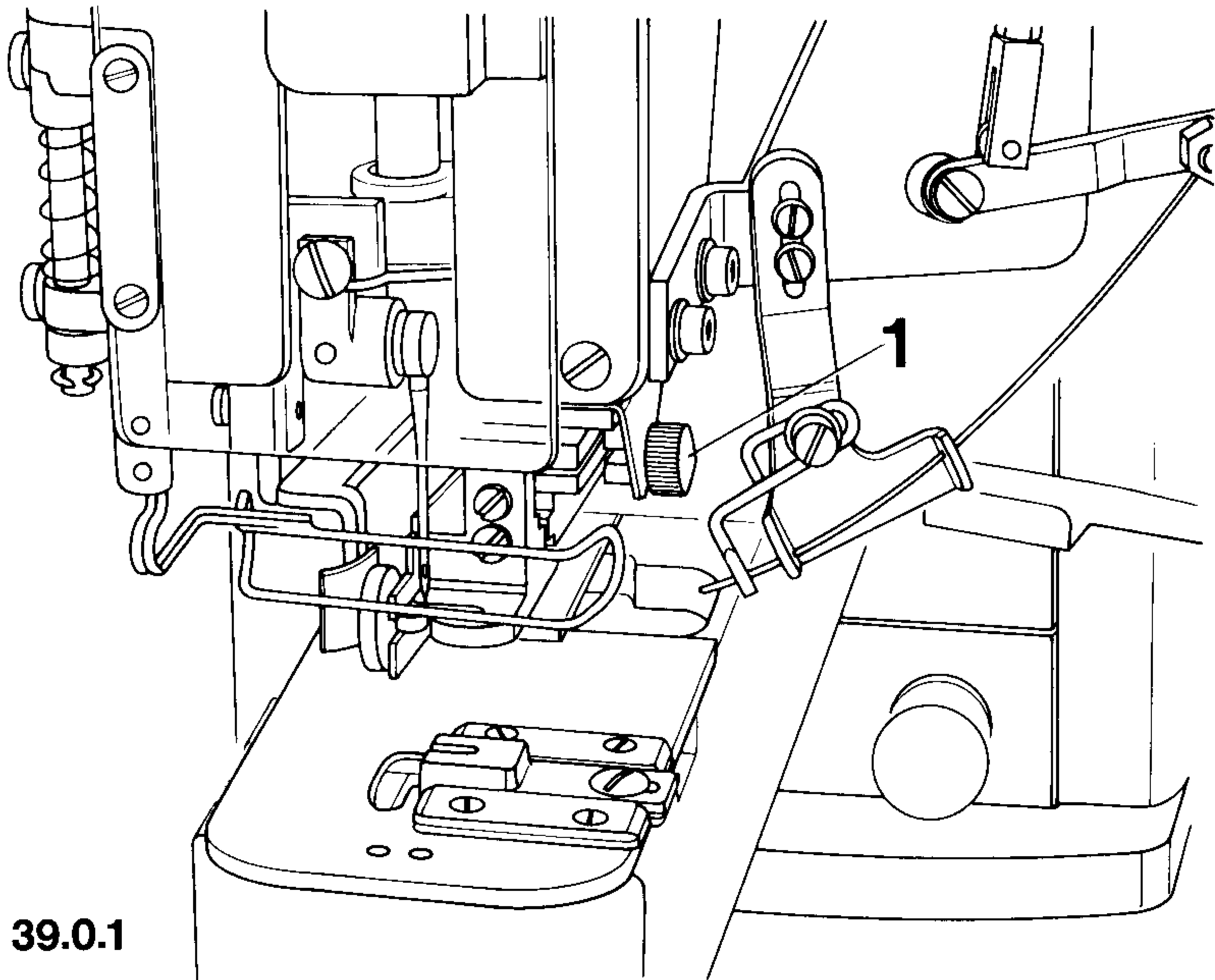

39.0.1

39.1 Adapt the stitch width to the button shank on the star knob.

39.2 **Adjust button shank relative to the stitch width at screw 1 according to “Correct setting”.**

Correct setting:

When the button clamp is lowered, retaining clamp 3 must rest lightly against the workpiece and not be deflected.

40.0.1

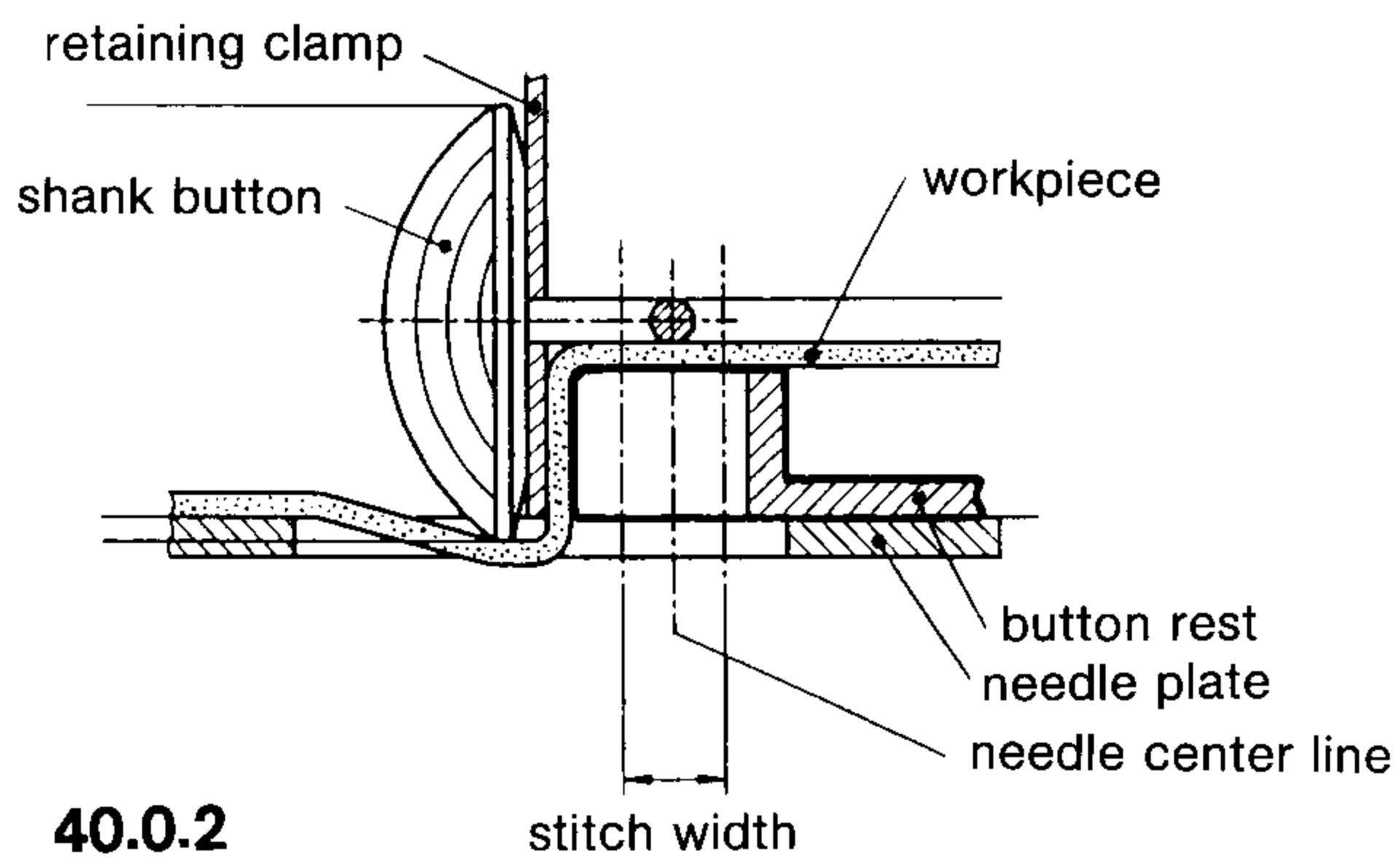
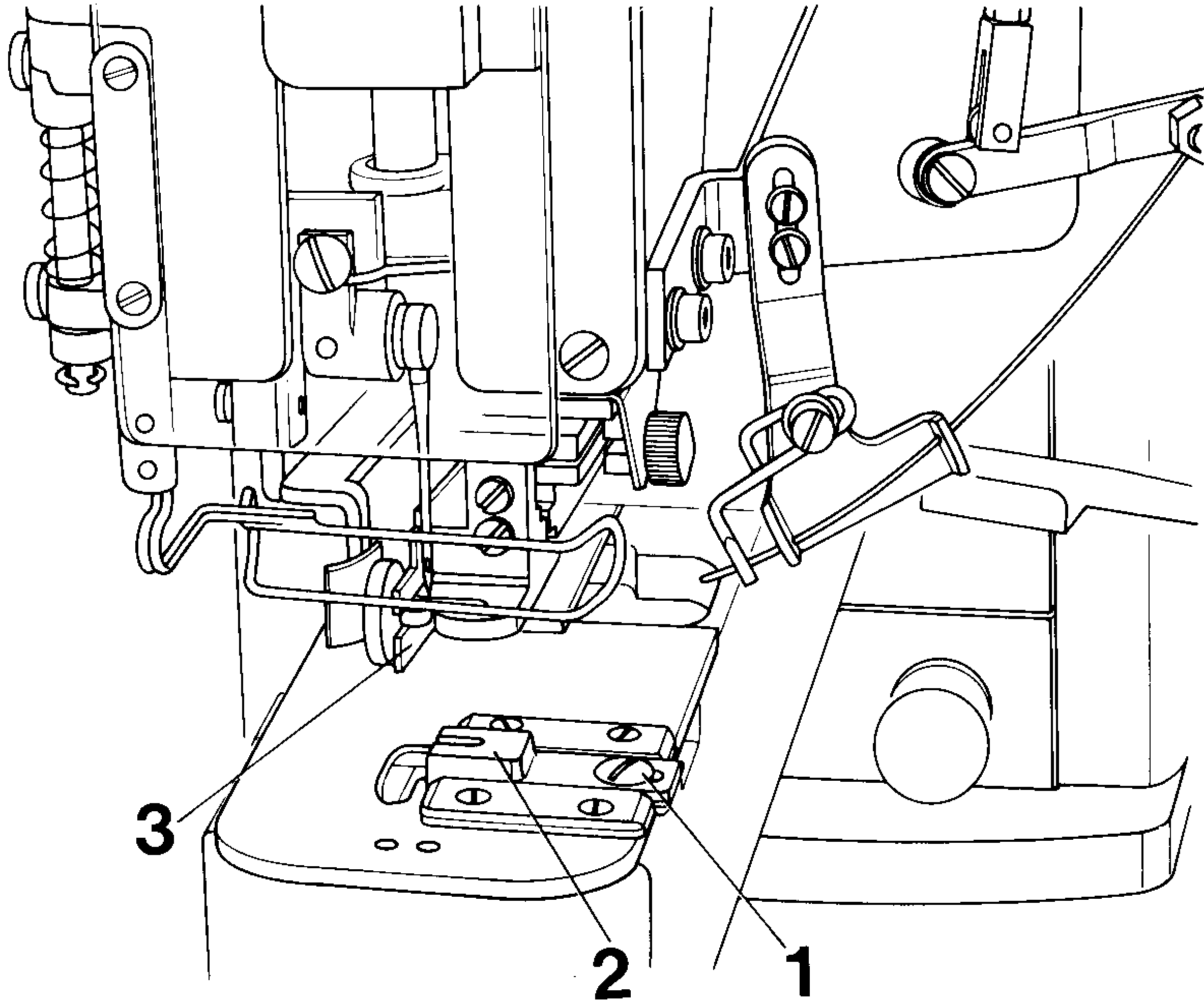

40.0.2

40.1

Loosen screw 1.

40.2

Move button rest 2 against the inserted workpiece and tighten screw 1.

Contents

Page

1	Preliminary adjustment of needle bar height	3
2	Preliminary adjustment of control cam	4
3	Centering the needle throw in the needle slot	5
4	Centering the smallest needle throw within the largest needle throw	6
5	Adjusting the lengthwise movement of the control bar	8
6	Driving belt inside the machine	9
7	Drag link assembly	10
8	Positioning the looper shaft in relation to the needle	12
9	Basic setting of thread trimming knife	13
10	Timing the looper and setting the looper-to-needle clearance	14
11	Checking the drag link	16
12	Final adjustment of needle bar height	17
13	Blind looper	18
14	Basic setting of thread loop support	20
15	Button clamp	22
16	Presser bar	24
17	Thread trapper push rod	25
18	Automatic thread tension	26
19	Final adjustment of control cam	27
20	Thread trapper	28
21	Thread trapper actuating segment	30
22	Stop mechanism	32
23	Stop-motion trip	34
24	Engaging lever	36
25	Locking lever	38
26	Declutching mechanism	40
27	Oil supply	42
28	Switches (on machines with subcl. -966/.. and -967/..)	43
29	Locking lever (on subcl. -966/13 machines)	46
30	Thread puller	48

Deviating adjustments on machines with subclass -9/..

31	Clamp position lengthwise to the arm	49
32	Clamp position crosswise to the arm	50
33	Thread trimmer knife	51
34	Resting position of the spreader	52
35	Spreader guide	53
36	Thread wiper	54

Deviating adjustments on machines with subclass 15/..

37	Shank guiding plate	55
38	Button clamp (lengthwise to the arm)	56
39	Button clamp (crosswise to the arm)	57
40	Button rest	58

PFAFF

PFAFF
Postfach 3020/3040
Königstraße 154
D-6750 Kaiserslautern

Telefon: (06 31) 200-0
Telefax: (06 31) 172 02
Telex: 45 753

Rohr
Gedruckt in der BRD