

**PFAFF**® **1445**  
**1446**

# **Service manual**



## Contents

	Page
1 Scale ring in reverse-feed control . . . . .	5
2 Zeroing top-, bottom- and needle feed . . . . .	6
3 Feeding motion of top-, bottom- and needle feed . . . . .	8
4 Bottom feed lifting motion . . . . .	9
5 Feed dog height . . . . .	10
6 Centering needles in needle holes . . . . .	11
7 Synchronizing the feeds . . . . .	12
8 Needle height (preliminary adjustment) . . . . .	13
9 Hook clearance, hook timing, needle-bar height and needle guard setting . . . . .	14
10 Bobbin case openers . . . . .	16–19
11 Oil check valve . . . . .	20
12 Top-feed stroke adjustment on machines without -918/09 . . . . .	22
13 Top-feed stroke adjustment on machines with -918/09 . . . . .	23
14 Setting vibrating presser in relation to lifting presser on machines without -918/09 . . . . .	24
15 Setting vibrating presser in relation to lifting presser on machines with -918/09 . . . . .	25
16 Stroke limitation on machines without -918/09 . . . . .	26
17 Stroke limitation on machines with -918/09 . . . . .	27
18 Top feed lifting stroke . . . . .	28
19 Knee lever play . . . . .	29
20 Fabric clearance . . . . .	30
21 Most convenient knee-lever resting position . . . . .	31
22 Needle thread tension release . . . . .	32
23 Hook lubrication . . . . .	33
24 Bobbin winders . . . . .	34
25 Thread check springs . . . . .	35
26 Maximum speeds . . . . .	36
27 Quick-change stepping control -918/09 . . . . .	37
28 After-braking action . . . . .	38
29 Reversing mechanism -913/08 . . . . .	39

**Notes on safe machine operation:**

The machine must only be used for the purpose it has been designed for.

When converting it to another version, all valid safety rules must be followed.

Service and repair work must only be performed by qualified personnel.

Work on live parts is not permitted, apart from exceptions according to DIN 57105 and VDE 0105.

**Important note:**

This Service Manual applies also to the Pfaff 1445 and 1446. Deviations in the illustrations do not affect the adjustment of the machines. The Service Manual is based on a two-needle machine. When adjusting a single-needle machine, simply ignore the adjustment procedure for the left needle and the left sewing hook.

A separate Service Manual is available for adjusting the thread trimmer -900/56 or -900/61 (publ. No. 296-12-14827).

**Tools, gauges and other items required for adjusting Pfaff machines 1445 and 1446**

1 set of screwdrivers with blades from 2 to 10 mm wide

1 set of wrenches with openings from 7 to 14 mm wide

1 set of allen keys from 2 to 6 mm

1 needle rise gauge, part No. 08-880136-01

1 C-clamp, part No. 08-880137-00

1 metal rule

1 wrapper of needles: system 134-35

2 strips of white paper

Sewing thread and testing material

1

## Scale ring in reverse-feed control

Requirement:

With the stitch length set at "0", the "0" mark on scale ring **3** should be opposite mark **4**.

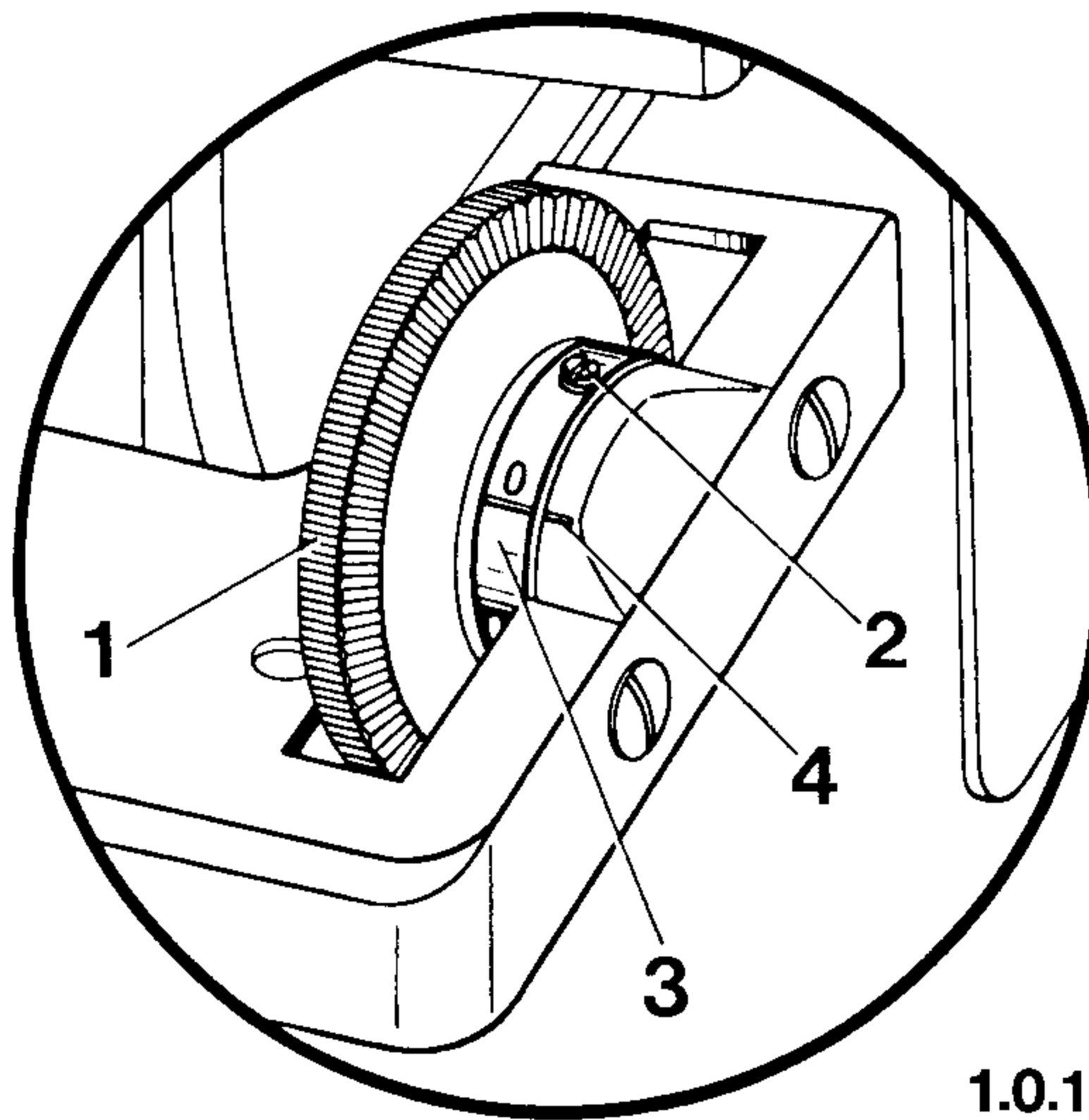

Adjustment:

- 1.1 Take the needles out of the needle holder.
- 1.2 Remove both knee lever and clutch piece.
- 1.3 Turn knurled disc **1 as far as it will go** in the direction the reverse-feed control starts to move downwards.
- 1.4 **Loosen screw 2 and turn scale ring 3 until the "0" mark is opposite mark 4.**
- 1.5 In this position, tighten screw **2**.

## 2

### Zeroing top-, bottom-, and needle feeds

Requirement:

With the stitch length set a **0** top feed, bottom feed and needle bar must not make any feeding movement when the balance wheel is turned.

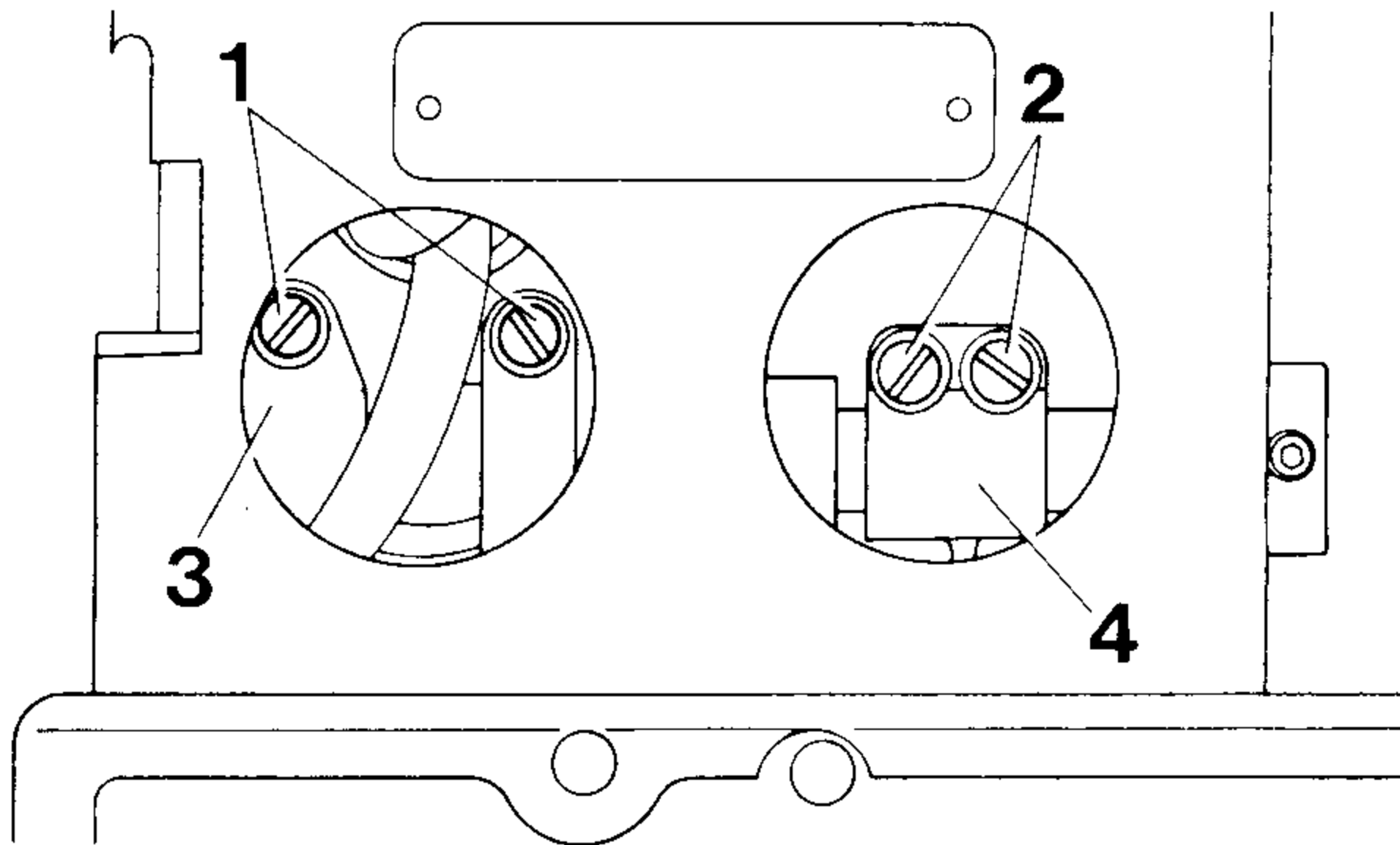

2.0.1

Adjustment:

- 2.1 Remove the two plastic grommets at the rear side of the arm standard.
- 2.2 Remove the gear cover at the base of the machine and allow any oil to drain out.
- 2.3 Set stitch length **0**.
- 2.4 Loosen screws **1** and **2** just enough to allow cranks **3** (bottom feed) and **4** (top- and needle feed) to turn tightly.

- 2.5 **Position connecting rods 5 (bottom feed) and 6 (top- and needle feed) so that when the balance wheel is turned, top feed, bottom feed and needle bar make no feeding movement.**
- 2.6 In this position tighten screws 1 and 2 firmly.
- 2.7 Carry out a check (see "Requirement").
- 2.8 Fit the two plastic grommets.

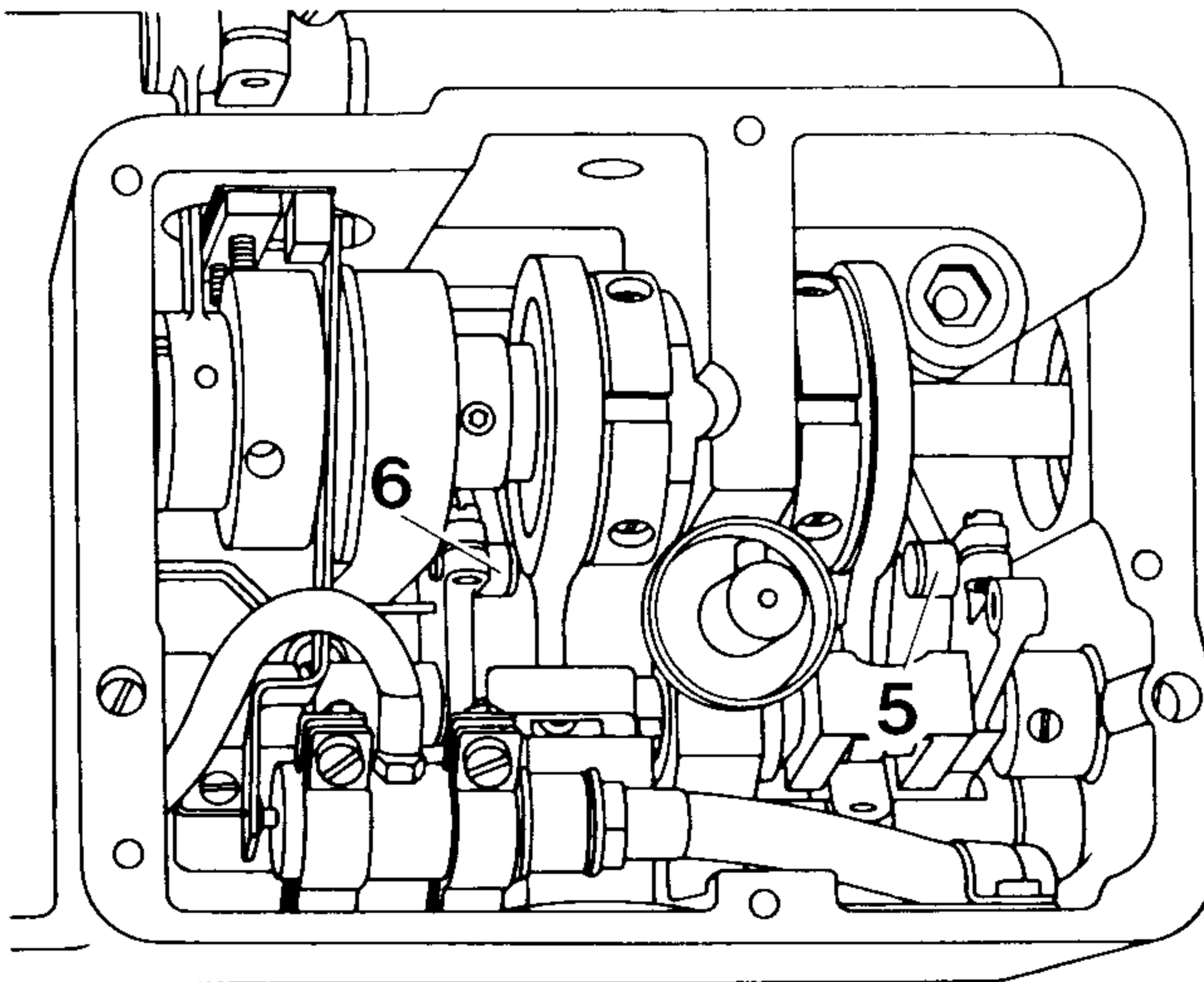

**2.0.2**

### 3

### Feeding motion of top-, bottom- and needle feed

Requirement:

With the longest stitch length set and the needle bar at bottom dead centre, top-, bottom- and needle feed must not make any feeding motion when the reverse-feed lever is operated.

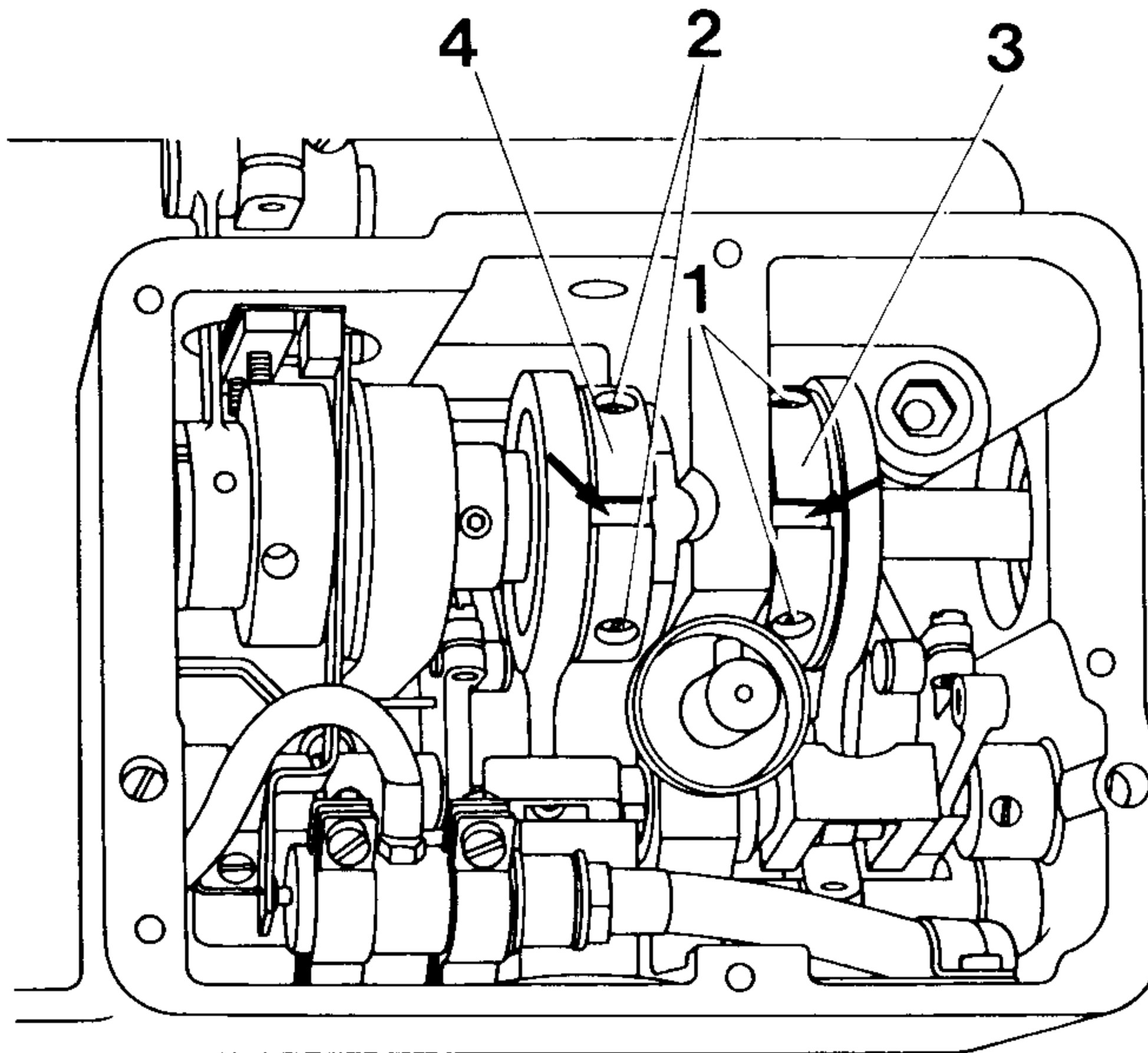

**3.0.1**

Adjustment:

- 3.1 Loosen screws **1** and **2** in eccentrics **3** and **4** just enough to allow the eccentrics to turn tightly.
- 3.2 Move the needle bar to top dead centre and set the longest stitch length.
- 3.3 Move the C-clamp up against the needle bar frame and tighten it in position.
- 3.4 Move the reverse-feed lever continuously up and down and turn eccentric **3** until the cutout in the eccentric (see arrow) becomes visible and the bottom feed dog no longer moves.
- 3.5 In this position tighten screws **1** firmly.
- 3.6 Move the reverse-feed lever continuously up and down and turn eccentric **4** until the cutout in the eccentric (see arrow) becomes visible and top feed and needle bar no longer move.
- 3.7 In this position tighten screws **2** firmly.
- 3.8 Remove the C-clamp from the needle bar.
- 3.9 Carry out a check (see "Requirement").



## 4

### Bottom feed lifting motion

Requirement:

When the needle bar is at bottom dead center, the feed dog should be at its highest point.

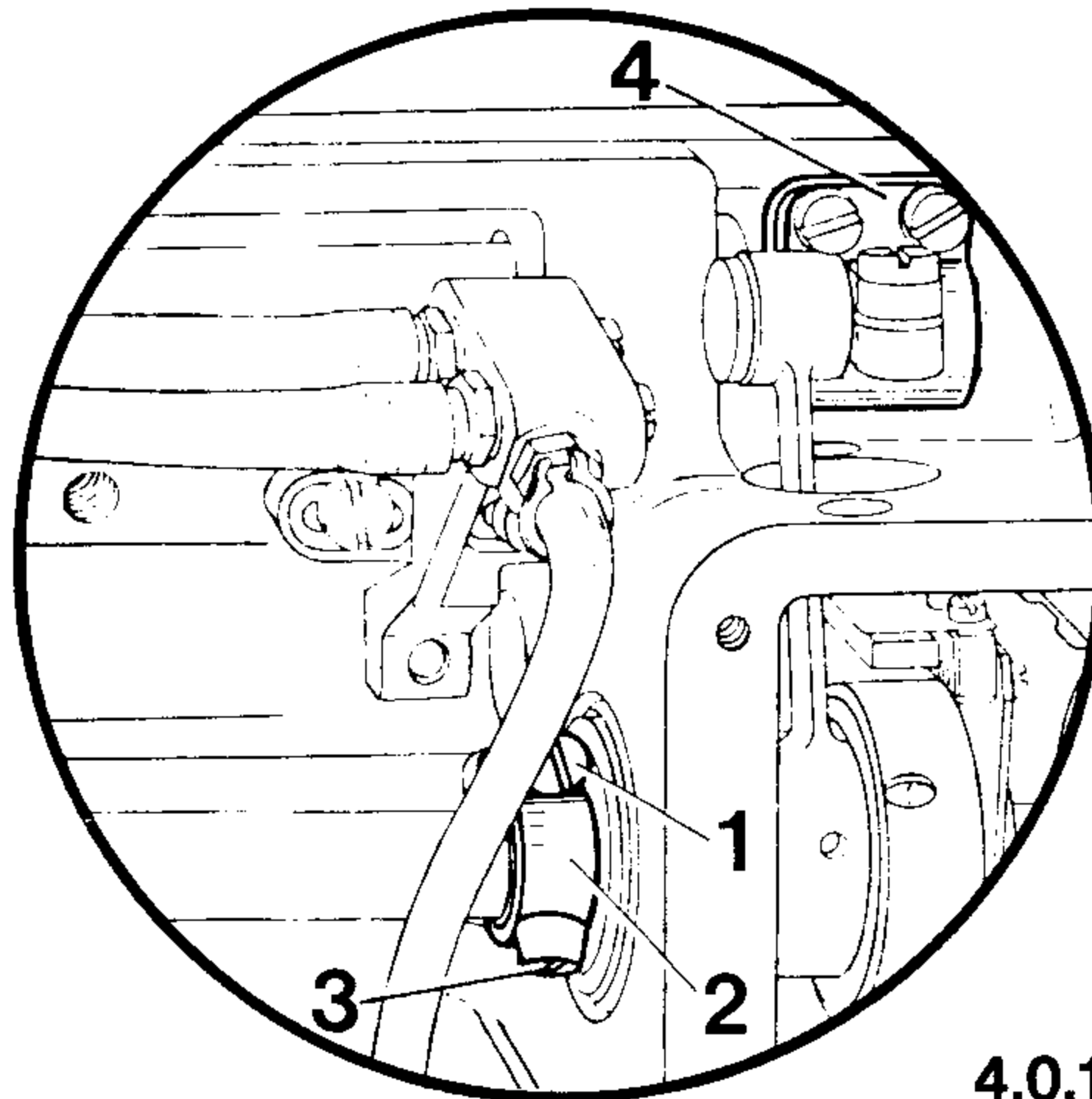

4.0.1

Adjustment:

- 4.1 Set the stitch length at "0".
- 4.2 Loosen screw 1.
- 4.3 Loosen screw 3 in collar 2 by half a turn.
- 4.4 Insert a screwdriver in the slot of bottom feed lifting crank 4 and bring the needle bar to bottom dead center.
- 4.5 Push the C-clamp onto the needle bar, push it up against the needle bar frame and tighten its screw.
- 4.6 **Turn collar 2 on the collar of the lifting eccentric until the feed dog (or screwdriver) is at bottom dead center.**
- 4.7 In this position, tighten screw 3.
- 4.8 Remove the C-clamp from the needle bar and tighten screw 1.
- 4.9 Pull the screwdriver out of the slot of bottom feed lifting crank 4 and check this adjustment (see "Requirement").

## 5

## Feed dog height

Requirement:

With the stitch length set at "0" and the needle bar at bottom dead centre the teeth of the feed dog must project above the needle plate by **0.5 mm**. Also the feed dog must be positioned in the middle of the needle plate slots.

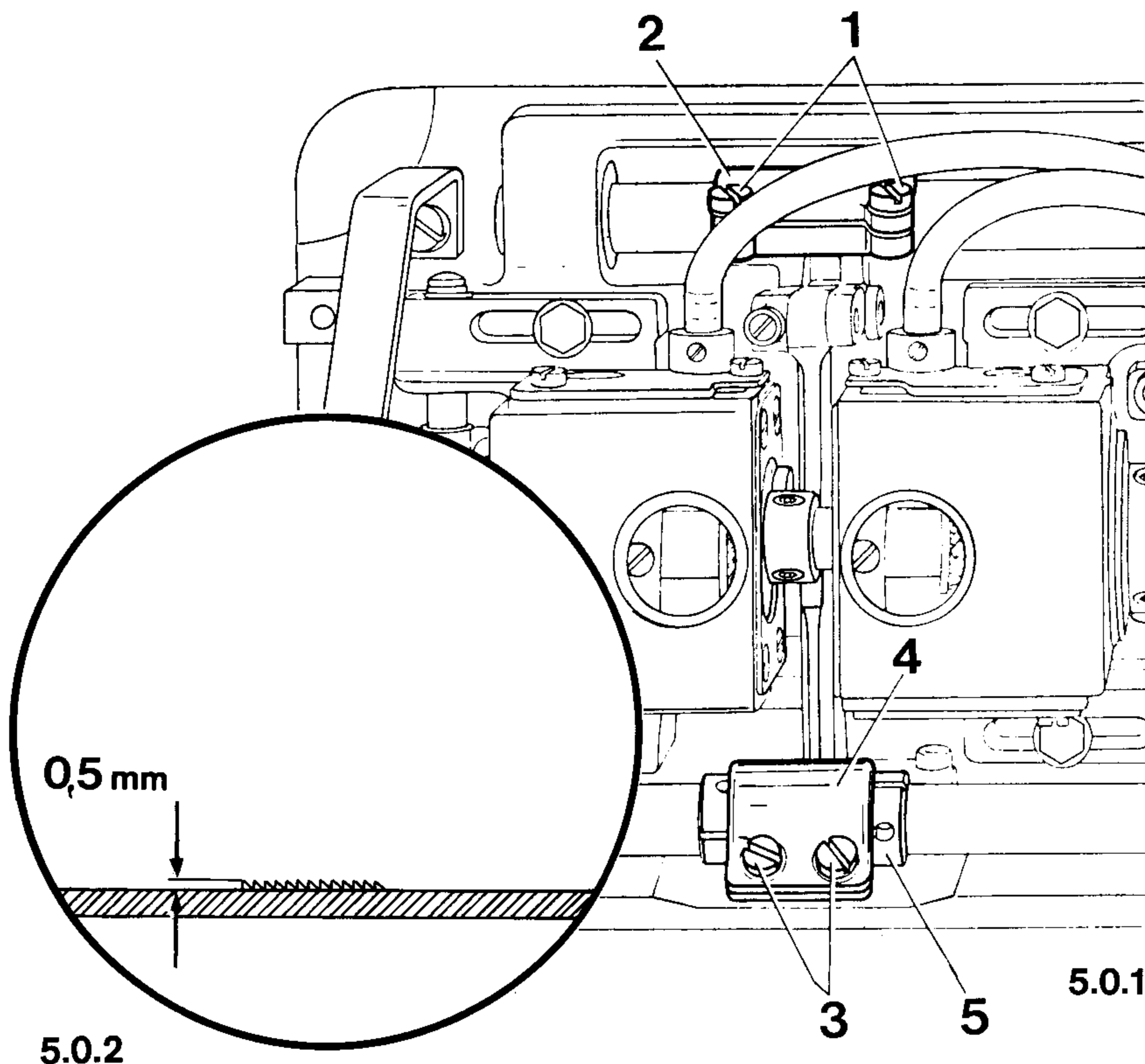

Adjustment:

- 5.1 Set the stitch length at "0".
- 5.2 Move the needle bar to top dead centre.
- 5.3 Loosen screws 1 of lifting crank 2 and screws 3 of feeding crank 4.
- 5.4 Turn lifting crank 2 so that the teeth of the feed dog project above the needle plate by 0.5 mm.
- 5.5 In this position tighten screws 1.
- 5.6 Turn eccentric clamp bush 5 until the feed dog is horizontal.
- 5.7 **Making sure that clamp bush 5 is not turned from this position, turn feeding crank 4 until the feed dog is in the middle of the needle plate slots.**
- 5.8 In this position tighten screws 3.
- 5.9 Carry out a check (see "Requirement").

## Centering needles in needle holes

Requirement:

With the stitch length set at "0" the needles must enter exactly in the centre of the needle holes (it is advisable to insert two new needles).

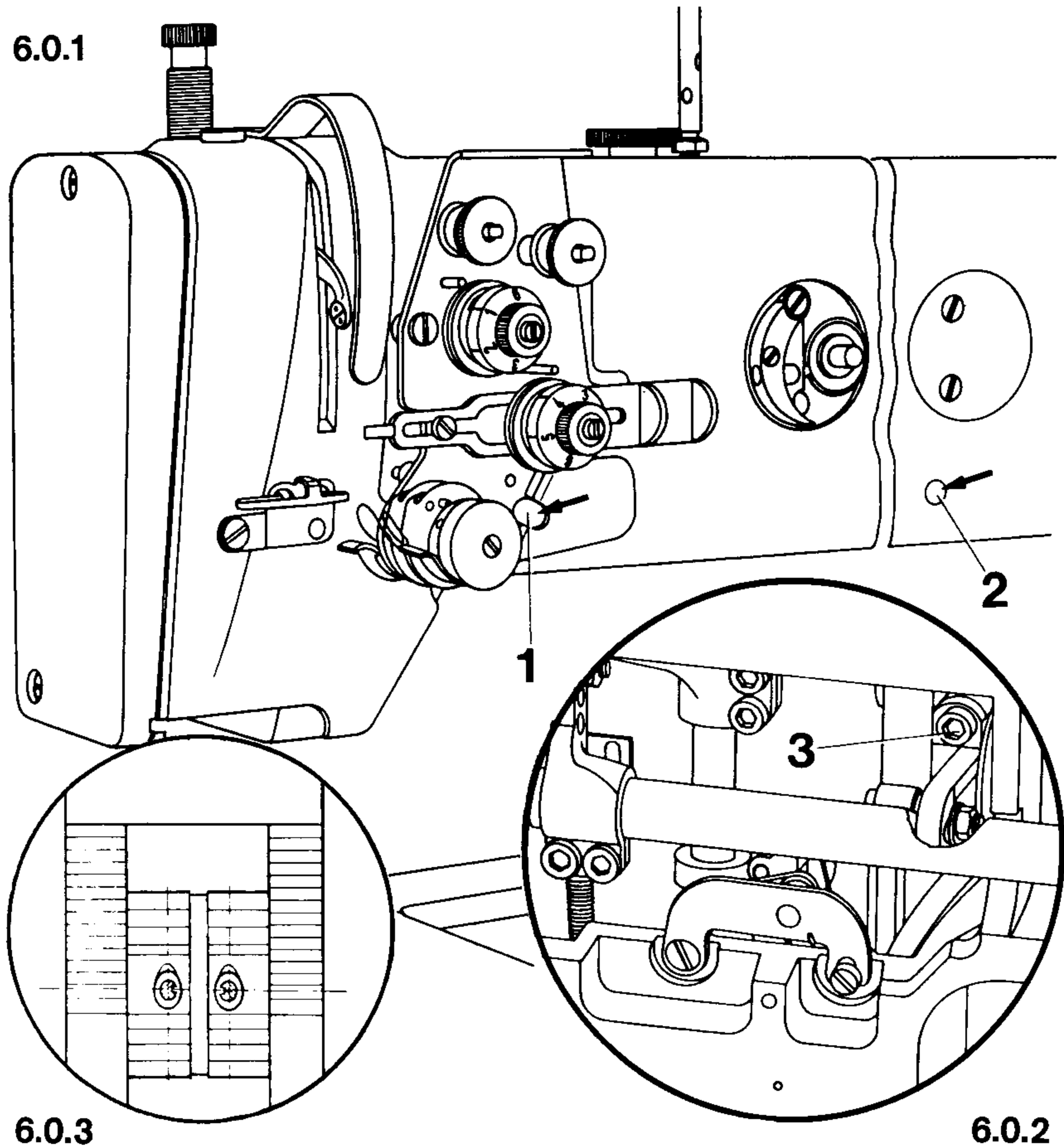

Adjustment:

- 6.1 Remove vibrating presser and presser foot.
- 6.2 Set the stitch length at "0" and move the needle bar to top dead centre.
- 6.3 Insert two new needles.
- 6.4 Remove the two covers at the rear of the machine.
- 6.5 Loosen screws 1 and 2 (see arrows) and screw 3 in the needle-bar drive crank.
- 6.6 Turn the balance wheel until the needles are positioned above the needle holes.
- 6.7 **Continue turning the balance wheel and adjust the needle bar frame, both lengthwise and crosswise of the feeding direction, so that the two needles enter exactly in the centre of the needle holes.**
- 6.8 In this position tighten screws 1, 2 and 3 firmly.

## 7

### Synchronizing the feeds

Requirement:

When the balance wheel is turned at the longest stitch length setting the needle and the bottom feed dog must make the same feeding stroke.

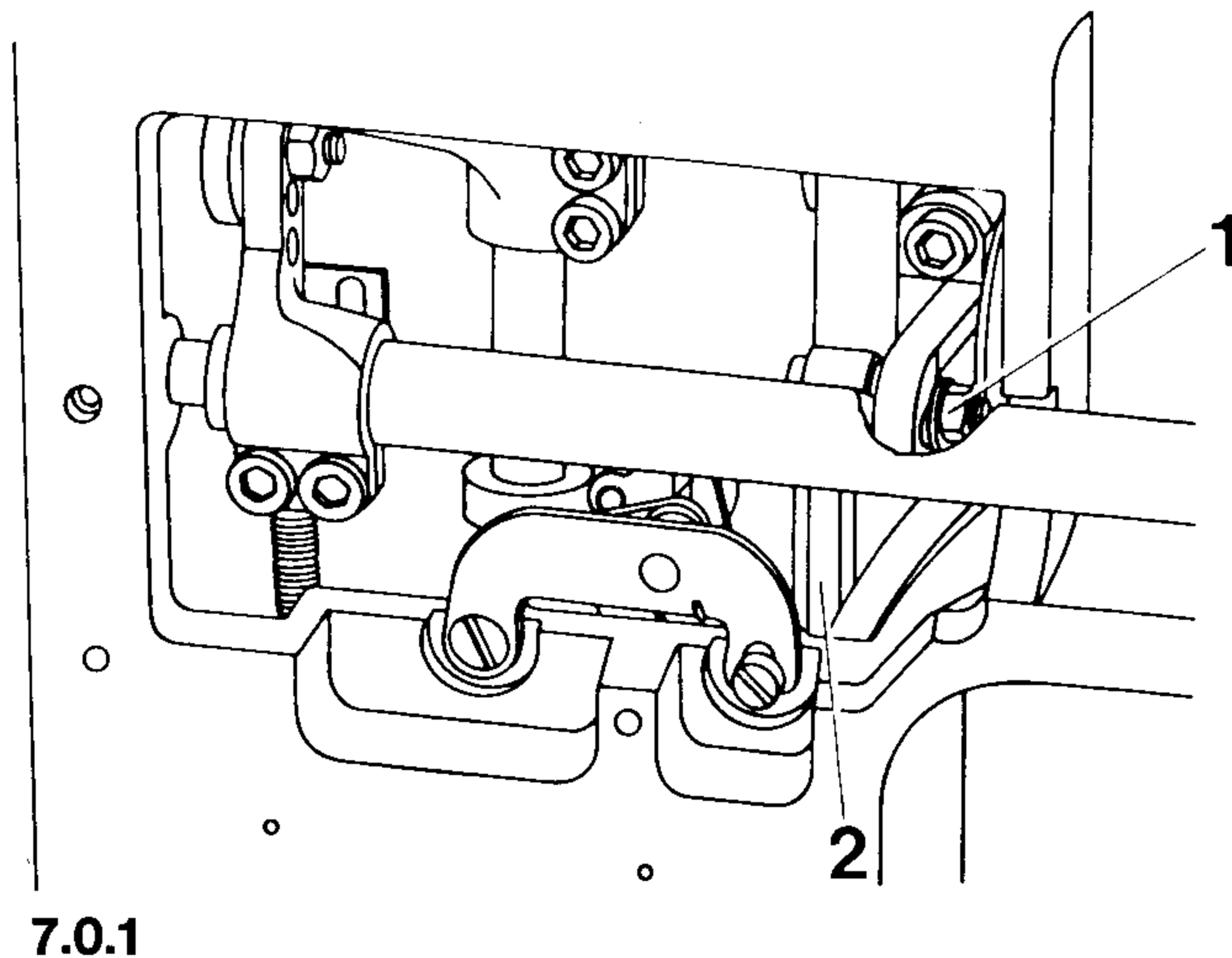

Adjustment:

- 7.1 Set the longest stitch.
- 7.2 **Loosen nut 1 and push connecting rod 2 so that the needle and feed dog make the same feeding stroke when the balance wheel is turned.**
- 7.3 In this position tighten nut 1.
- 7.4 Carry out a check (see "Requirement").
- 7.5 Check the adjustment described in section 6 and repeat if necessary.

8

**Needle height (preliminary adjustment)**

Requirement:

With the needle bar at top dead centre there must be a clearance of **19 mm** between needle point and needle plate.

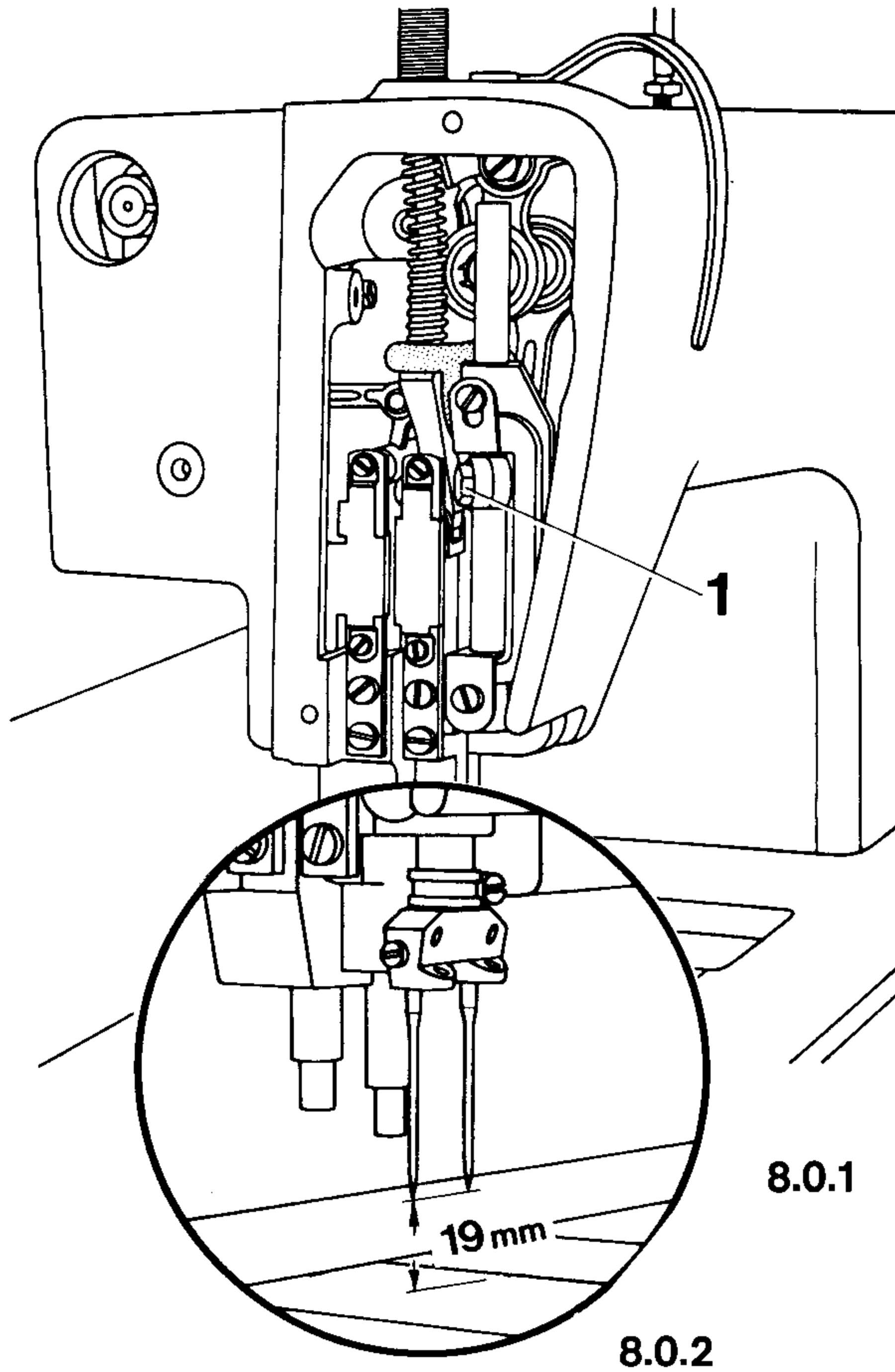

Adjustment:

- 8.1 Remove the face plate.
- 8.2 Move the needle bar to top dead centre and loosen hexagon screw 1.
- 8.3 **Adjust the height of the needle bar, without turning it, so that the clearance between needle point and needle plate is 19 mm.**
- 8.4 In this position tighten screw 1.

9 Hook clearance, hook timing, needle-bar height and needle-guard setting

9.1 Hook clearance, hook timing and needle bar height

Requirement:

With the stitch length set a 3mm and the needle bar positioned 2,0 mm past bottom dead center (needle rise position) each hook point should be exactly opposite the center line of the respective needle, the lateral clearance between hook point and needle being 0.05 - 0.1 mm. Also, in this position, the hook points should be positioned 0.8 mm above the top edge of the respective needle eye.

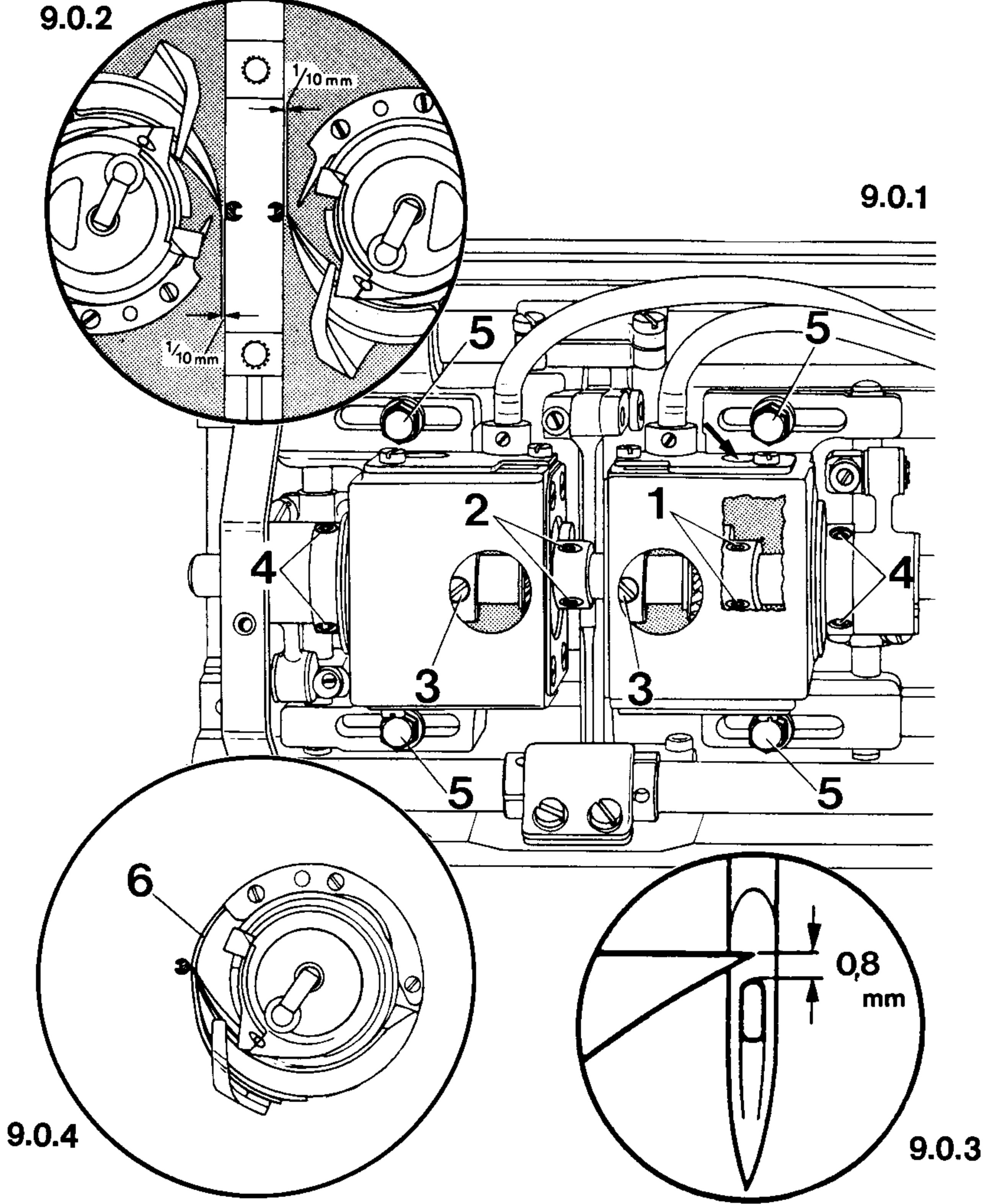

Adjustment:

9.1.1 Set the stitch length a 3 mm and unscrew the needle plate and the feed dog.

- 9.1.2 Loosen allen screws **1**, which are accessible through the hole in the bevel gear case cover, and allen screws **2** between both bevel gear cases.
- 9.1.3 Loosen both screws **3**, which are accessible through the holes in the bevel gear cases.
- 9.1.4 Loosen screws **4** and **5**.
- 9.1.5 Bring the needle bar to bottom dead center.
- 9.1.6 Push the 2.0-mm-thick blade of the gauge onto the needle bar immediately below its lower bearing, push the C-clamp up against the blade and tighten its screw.
- 9.1.7 Pull out the gauge and turn the balance wheel in its normal direction until the C-clamp contacts the needle bar bearing.
- 9.1.8 **Turn both hooks on their shafts to that their points are opposite the center line of the respective needle.** In this position (needle rise position), the hook points should be positioned **0.8 mm** above the top edge of the respective needle eye. If necessary, adjust the needle bar height.
- 9.1.9 **Adjust the hook bearing brackets laterally until there is a clearance of 0.05 – 0.1 mm between the hook points and the needles.**
- 9.1.10 In this position, securely tighten screws **5**.
- 9.1.11 Adjust the left part of the main drive shaft so that the clutch has a play of **0.5 mm**.
- 9.1.12 In this position, and making sure that the bevel gears are neither too close to each other nor have too much play, tighten screws **1** and **2**.
- 9.1.13 Tighten one each of screws **4**.
- 9.1.14 Push the bushings up against the bevel gears and tighten both screws **3** on each.
- 9.1.15 Remove the C-clamp from the needle bar. Check this adjustment (see “Requirement”).
- 9.1.16 Do not tighten the second screw **4** yet.

**9.2 Needle guard**

Requirement:

In the needle rise position, needle guard **6** must touch the needle lightly, in order to ensure that the needle is not struck by the looper point.

Adjustment:

- 9.2.1 Turn the balance wheel to move the needle to needle rise position.
- 9.2.2 Position needle guard **6** so that the needle touches it lightly but is not deflected.

## 10 Bobbin case openers

### 10.1 Right bobbin case opener eccentric

Requirement:

When the take-up lever is at bottom dead center, shaft 3 of the right bobbin case opener should be exactly at its rear point of reversal, as seen in the direction of feed (see arrow).

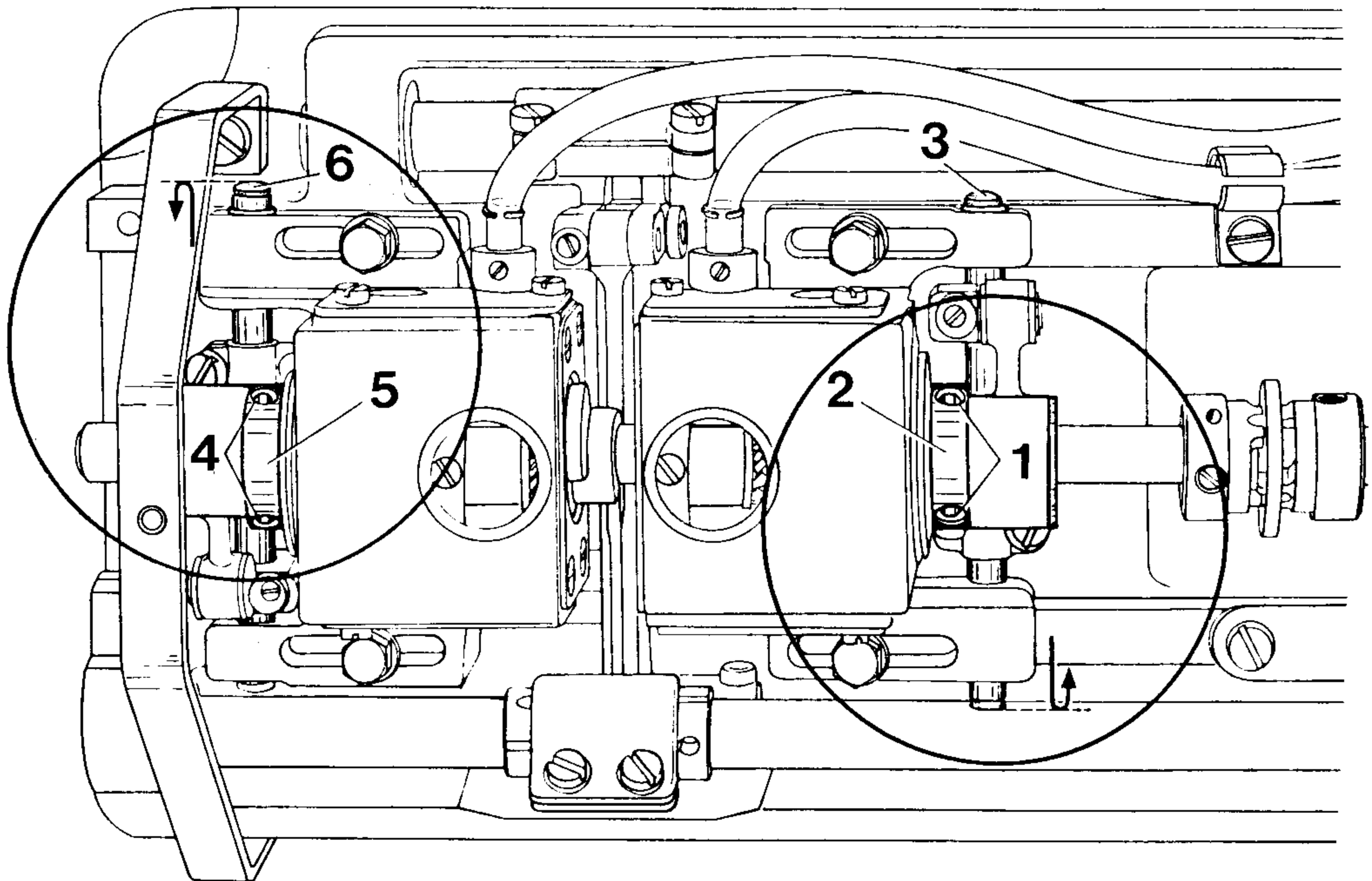

#### 10.0.1

Adjustment:

- 10.1.1 Screw on the feed dog.
- 10.1.2 Also screw on the needle plate, making sure that the lugs of both bobbin case bases enter the appropriate slots on the underside of the needle plate.
- 10.1.3 Loosen screw 1 in the right bobbin case opener eccentric, which was tightened previously.
- 10.1.4 Turn the balance wheel to bring the take-up lever to bottom dead center.
- 10.1.5 **Turn the right bobbin case opener eccentric 2 on its shaft until shaft 3 is exactly at its rear point of reversal (see arrow).**
- 10.1.6 In this position, tighten screws 1 securely.



10.2 **Left bobbin case opener eccentric**

Requirement:

When the take-up lever is at bottom dead center, shaft <b>6</b> of the left bobbin case opener should be exactly at its front point of reversal, as seen in the direction of feed (see arrow).
--

Adjustment:

- 10.2.1 Loosen screw **4** in the left bobbin case opener eccentric, which was tightened previously.
- 10.2.2 Turn the balance wheel to bring the take-up lever to bottom dead center.
- 10.2.3 **Turn the left bobbin case opener eccentric 5 on its shaft until shaft 6 its exactly at its front point of reversal (see arrow).**
- 10.2.4 In this position, tighten screw **4** securely.

## 10.3

**Right bobbin case opener**

Requirement:

When shaft 1 of the right bobbin case opener is at its rear point of reversal (see arrow), as seen in the direction of feed, there should be a clearance of 0.3 to 0.5 mm between the lug of the right bobbin case base and the rear edge of the needle plate slot.

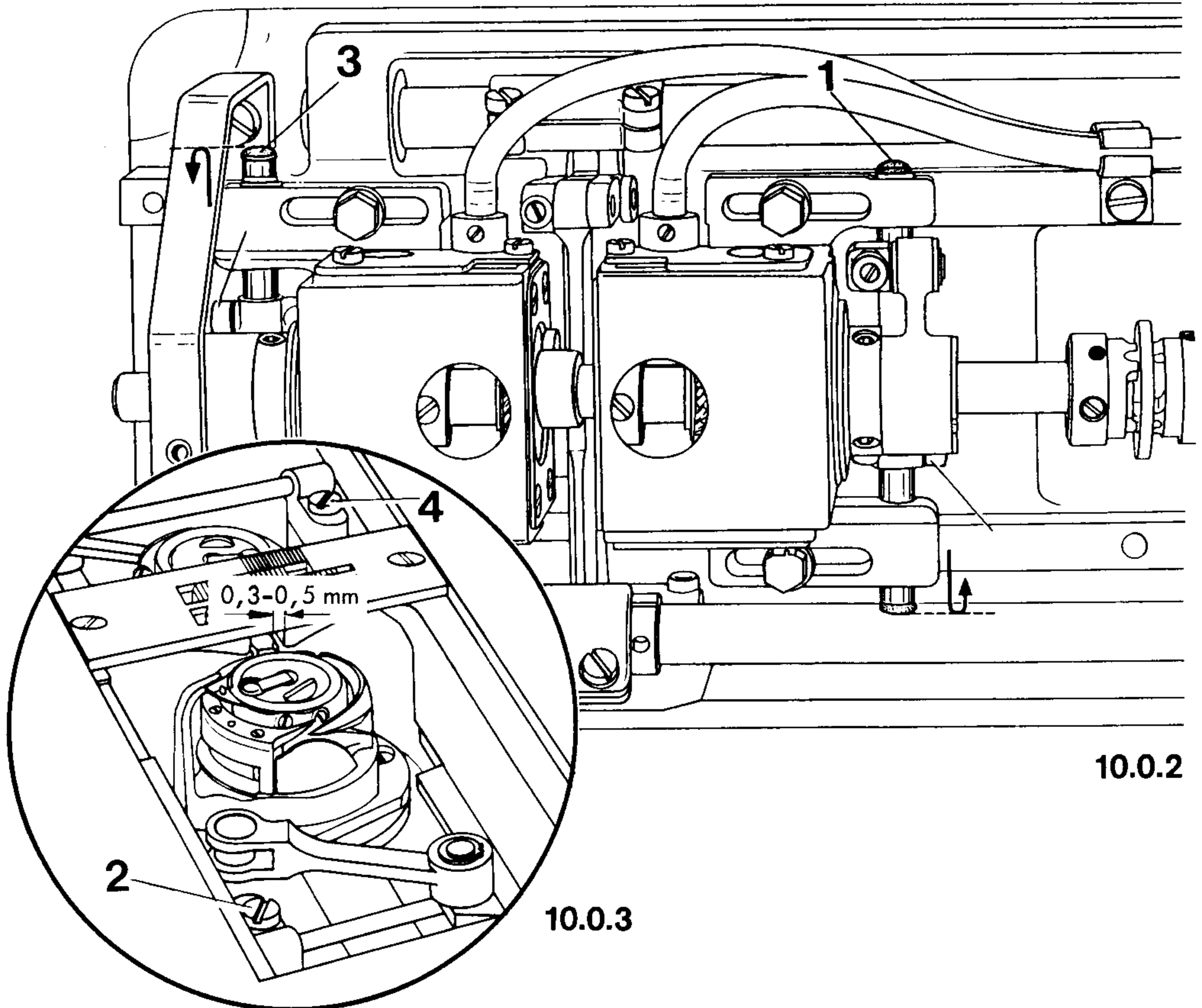

10.0.2

10.0.3

Adjustment:

- 10.3.1 Bring the needle bar to bottom dead center.
- 10.3.2 Turn the balance wheel in its normal direction until shaft 1 of the right bobbin case opener is at its rear point of reversal (see arrow).
- 10.3.3 Loosen clamp screw 2 of the connecting crank on the right shaft 1.
- 10.3.4 **Reposition the connecting crank on its shaft so that there is a clearance of 0.3 to 0.5 mm between the lug of the right bobbin case base and the rear edge of the needle plate slot.**
- 10.3.5 In this position, tighten clamp screw 2, making sure that the connecting crank is not tilted.
- 10.3.6 Check this adjustment (see "Requirement").

## 10.4 Left bobbin case opener

Requirement:

When shaft **3** of the left bobbin case opener is at its front point of reversal (see arrow), as seen in the direction of feed, there should be a clearance of 0.3 to 0.5 mm between the lug of the left bobbin case base and the front edge of the needle plate slot.

Adjustment:

- 10.4.1 Bring the needle bar to bottom dead center.
- 10.4.2 Continue turning the balance wheel in its normal direction until shaft **3** of the left bobbin case opener is at its front point of reversal (see arrow).
- 10.4.3 Loosen clamp screw **4** of the connecting crank on the left shaft **3**.
- 10.4.4 **Reposition the connecting crank on its shaft so that there is a clearance of 0.3 to 0.5 mm between the lug of the left bobbin case base and the front edge of the needle plate slot.**
- 10.4.5 In this position, tighten clamp screw **4**, making sure that the connecting crank is not tilted.
- 10.4.6 Check this adjustment (see "Requirement").

Requirement:

With the machine in its inoperative position there must be a clearance of **0.3 mm** between actuating link **4** and centrifugal switch **5** at its narrowest point (see Fig. 11.0.1).  
Also, pin **7** must be set at the middle of the elongated hole and the circlip on the pin must rest lightly against the actuating link.

11.0.1

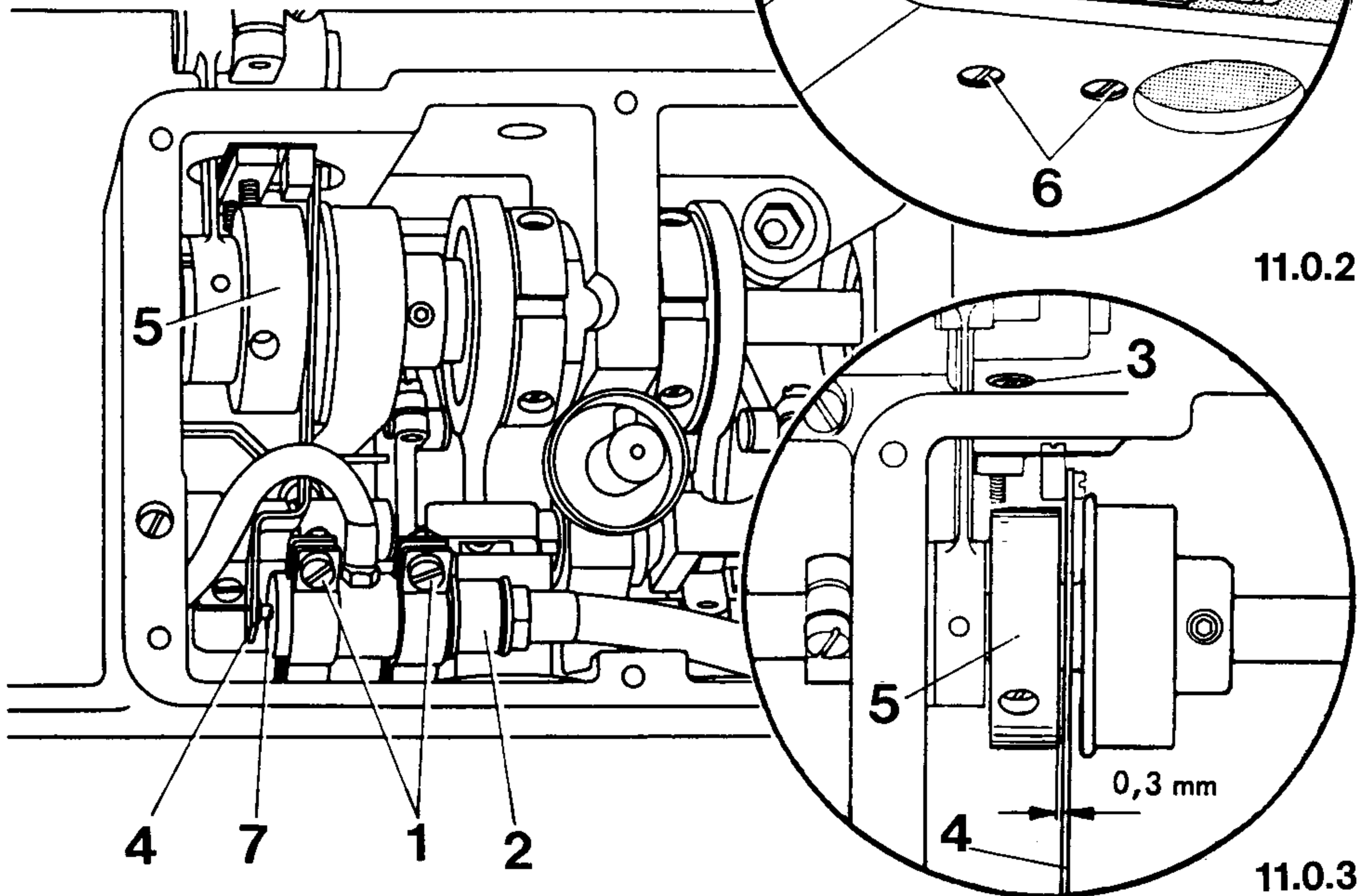

Adjustment:

- 11.1 Loosen the two clamp screws **1** and push oil check valve **2** to the right.
- 11.2 Also loosen retaining screws **3**.
- 11.3 **Position actuating link **4** so that in its resting position it clears centrifugal switch **5** by 0.3 mm.**

- 11.4 In this position tighten retaining screw 3.
- 11.5 Loosen retaining screws 2.
- 11.6 Push pin 7 to the right until you feel a pressure, then position clamp 8 so that pin 7 is in the middle of the elongated hole.
- 11.7 In this position tighten the two retaining screws 6.
- 11.8 **Adjust the position of oil check valve 2 so that the circlip on pin 7 rests lightly against actuating link 4, making sure that the pin is still at the pressure point.**
- 11.9 In this position tighten clamp screws 1.
- 11.10 Carefully clean the surface of the gearbox and the gasket of the gearbox cover.
- 11.11 Replace the gear cover with its 5 retaining screws (tightening the screws evenly crosswise).

Requirement:

With milled nut **1** turned out as far as it will go, crank **4** must not move when the balance wheel is turned.

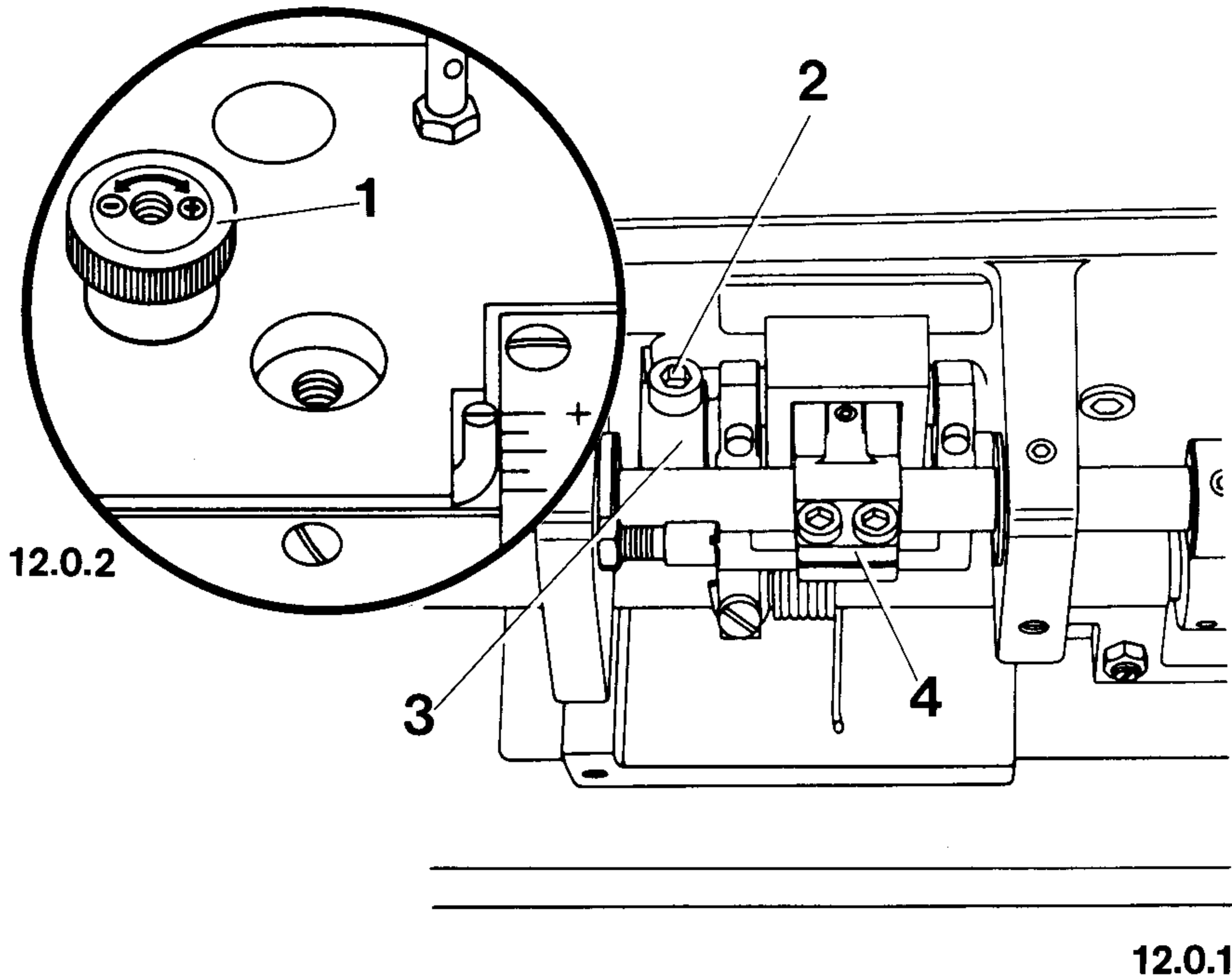

Adjustment:

- 12.1 Turn out milled nut **1** as far as it will go.
- 12.2 Loosen screw **2**.
- 12.3 **Turn crank **3** so that crank **4** no longer moves when the balance wheel is turned (to check this, insert a screwdriver in the hole of crank **4**).**
- 12.4 In this position, tighten screw **2**.

Requirement:

With the cylinder plunger extended and milled nut **1** turned out as far as it will go, there must be a clearance of approx. **5 mm** between crank **3** and shaft **4**.

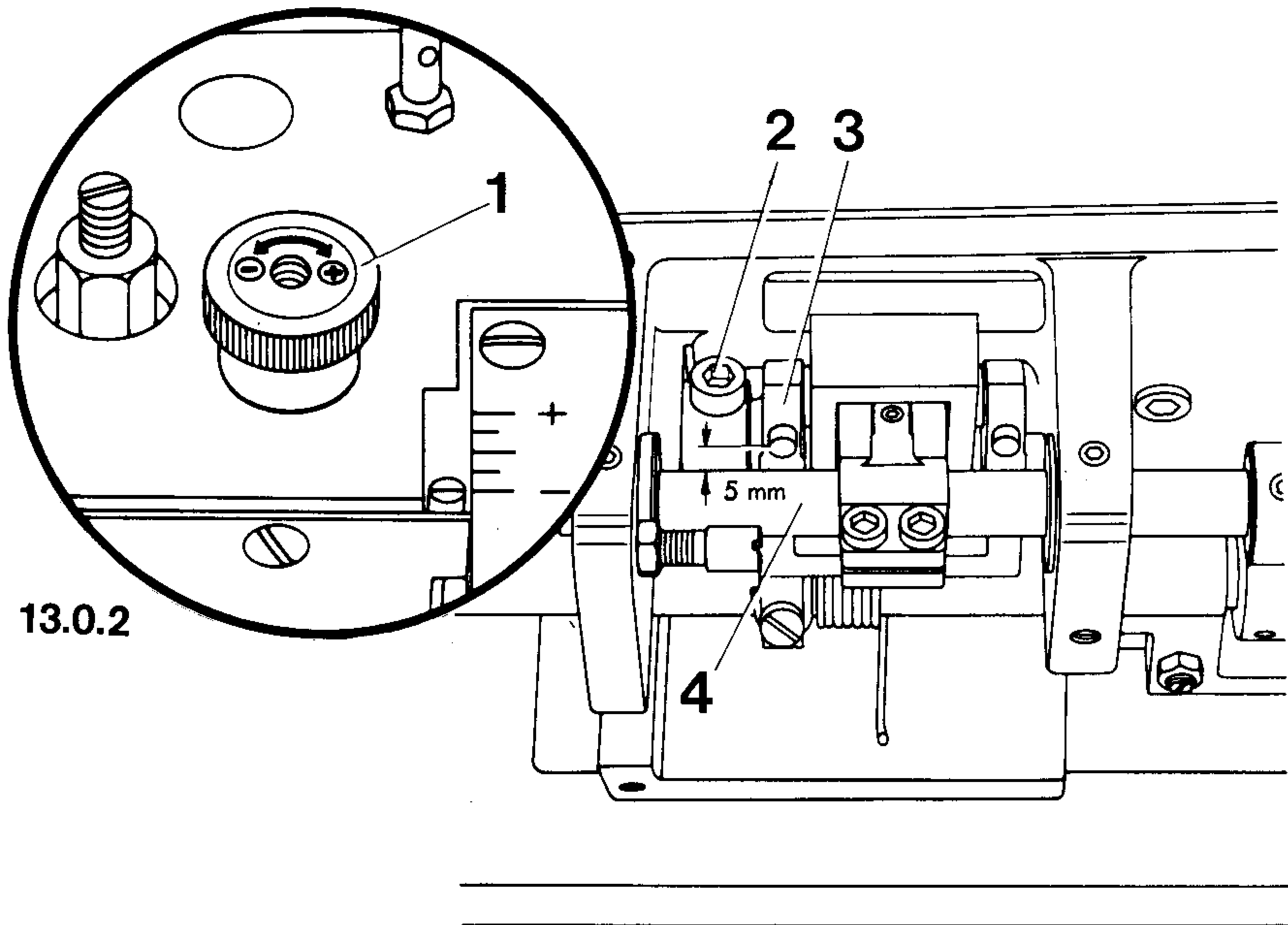

13.0.1

Adjustment:

- 13.1 Extend the cylinder plunger.
- 13.2 Turn out milled nut **1** as far as it will go.
- 13.3 Loosen screw **2**.
- 13.4 **Turn crank **4** until the clearance between shaft **4** and crank **3** is approx. 5 mm.**
- 13.5 In this position, tighten screw **2**.

**14**      **Setting the top feed dog in relation to the presser foot on machines without -918/09**

Require-  
ment:

When the balance wheel is turned, the stroke of the top feed dog must be **2 mm** and that of the presser foot **3 mm**.

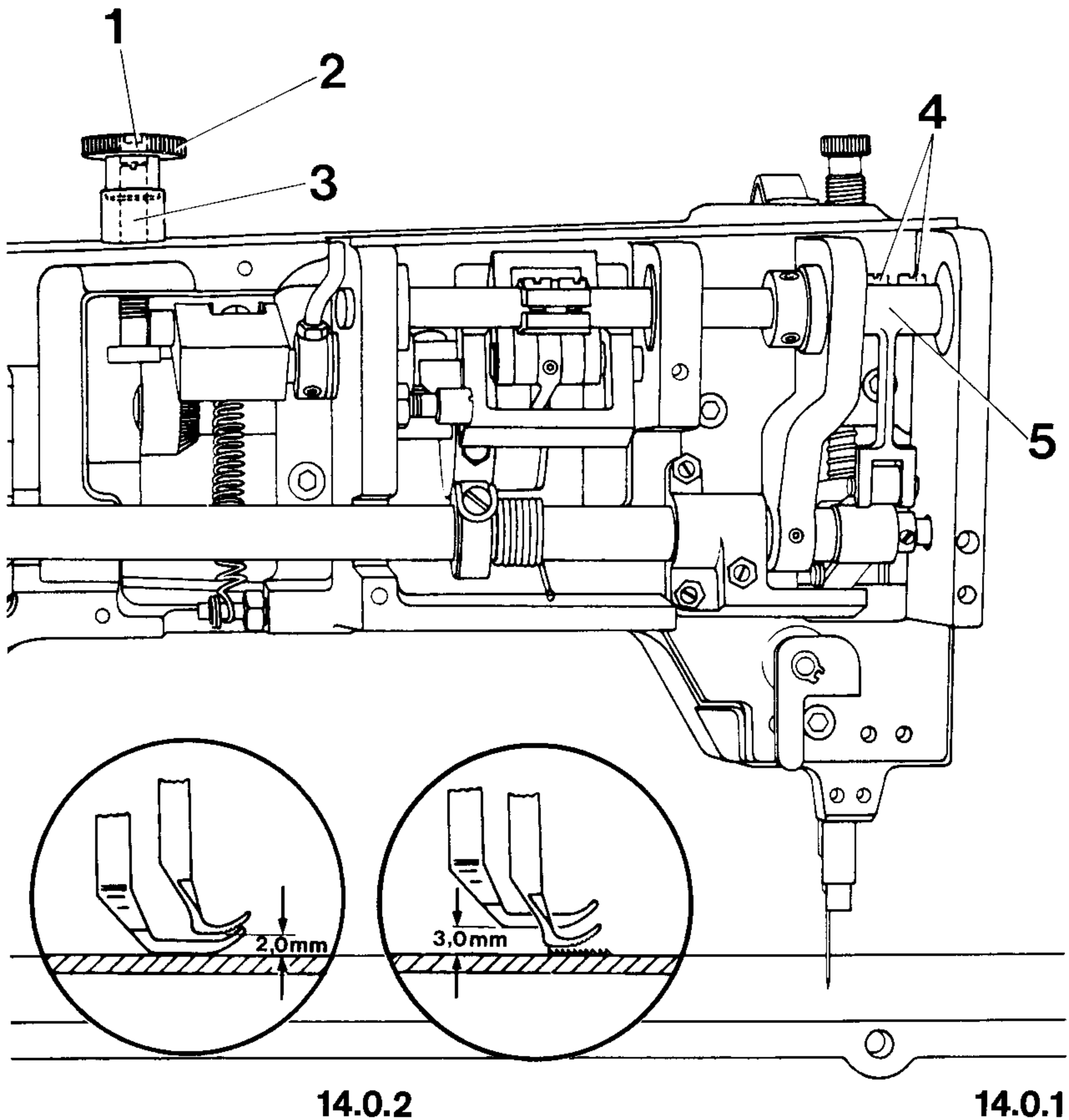

Adjustment:

- 14.1      Fit top feed dog and presser foot.
- 14.2      Remove allen screw 1 and screw milled nut 2 off threaded pin 3.
- 14.3      Turn out threaded pin 3 as far as it will go, then turn it back again by 4 turns.
- 14.4      **Loosen screws 4 and turn crank 5 so that the stroke of the top feed dog is 2 mm, and that of the presser foot 3 mm when the balance wheel is turned.**
- 14.5      Tighten screw 4.
- 14.6      Milled nut 2 will be tightened in Section 16.



**15 Setting the top feed dog in relation to the presser foot on machines with -918/09**

Requirement:

When the stroke of the top feed dog is **2 mm** when the balance wheel is turned, the stroke of the presser foot must be **3 mm**.

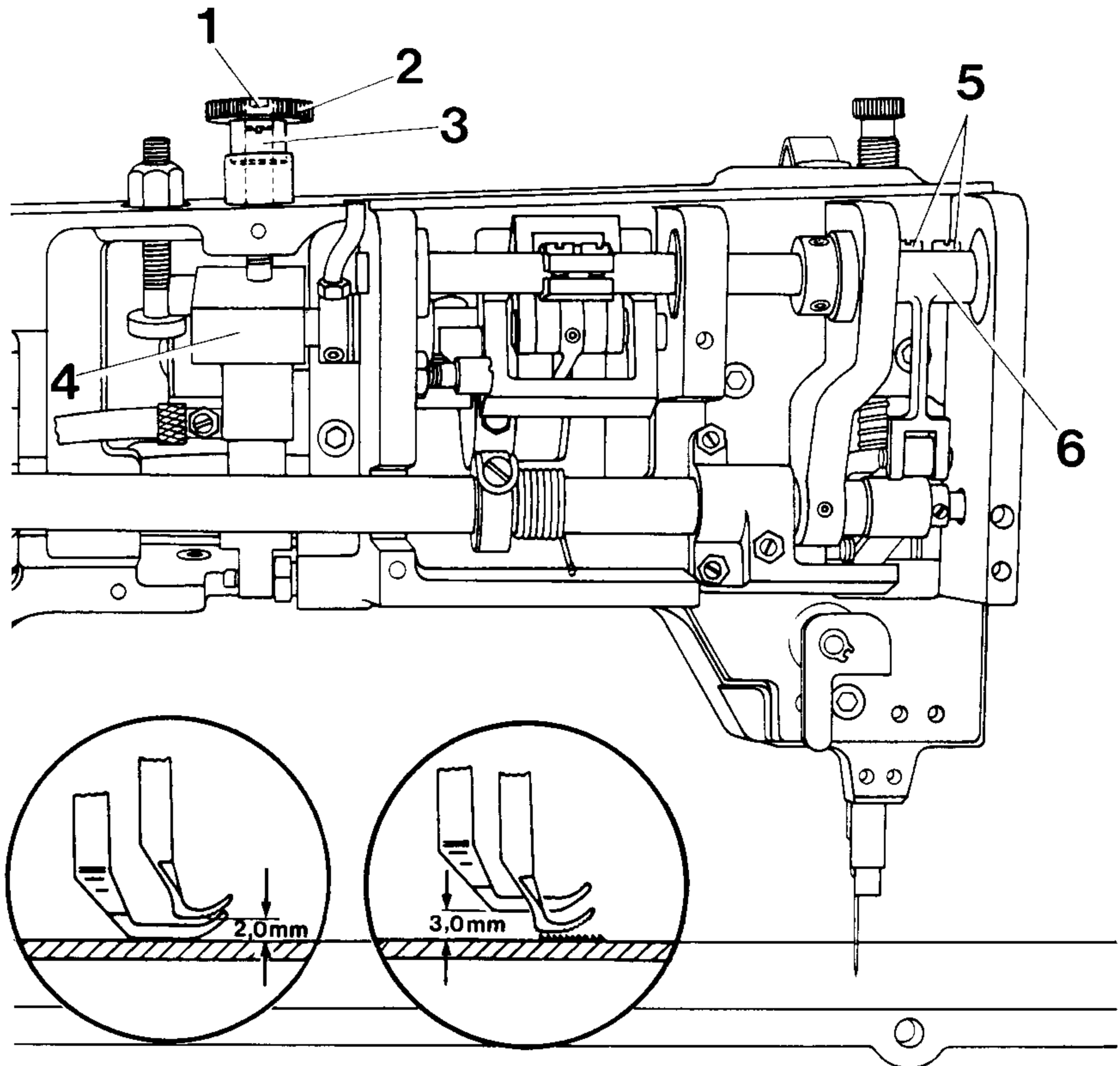

**15.0.2**

**15.0.1**

Adjustment:

- 15.1 Fit top feed dog and presser foot.
- 15.2 Extend cylinder plunger.
- 15.3 Remove allen screw **1** and milled nut **2** off threaded pin **3**.
- 15.4 Turn out threaded pin **3** as far as it will go.
- 15.5 Turn in threaded pin **3** until it is resting against crank **4**, then turn it in further by  $1\frac{1}{2}$  turns.
- 15.6 **Loosen screws **5** and turn crank **6** so that the stroke of the top feed dog is 2 mm and that of the presser foot 3 mm, when the balance wheel is turned.**
- 15.7 Tighten screws **5**.
- 15.8 Milled nut **2** will be tightened in Section 17.

Requirement:

With milled nut 5 resting on sleeve 7, the max. presser foot stroke\* must be 7 mm when the balance wheel is turned. The mark of pointer 9 must be opposite the "+" on the housing cover (Fig. 16.0.2).

Note:

\* At the factory, the maximum stroke is limited to 5.5 mm on eccentric 3. When setting a higher stroke, observe the maximum speed (see table on page 36).

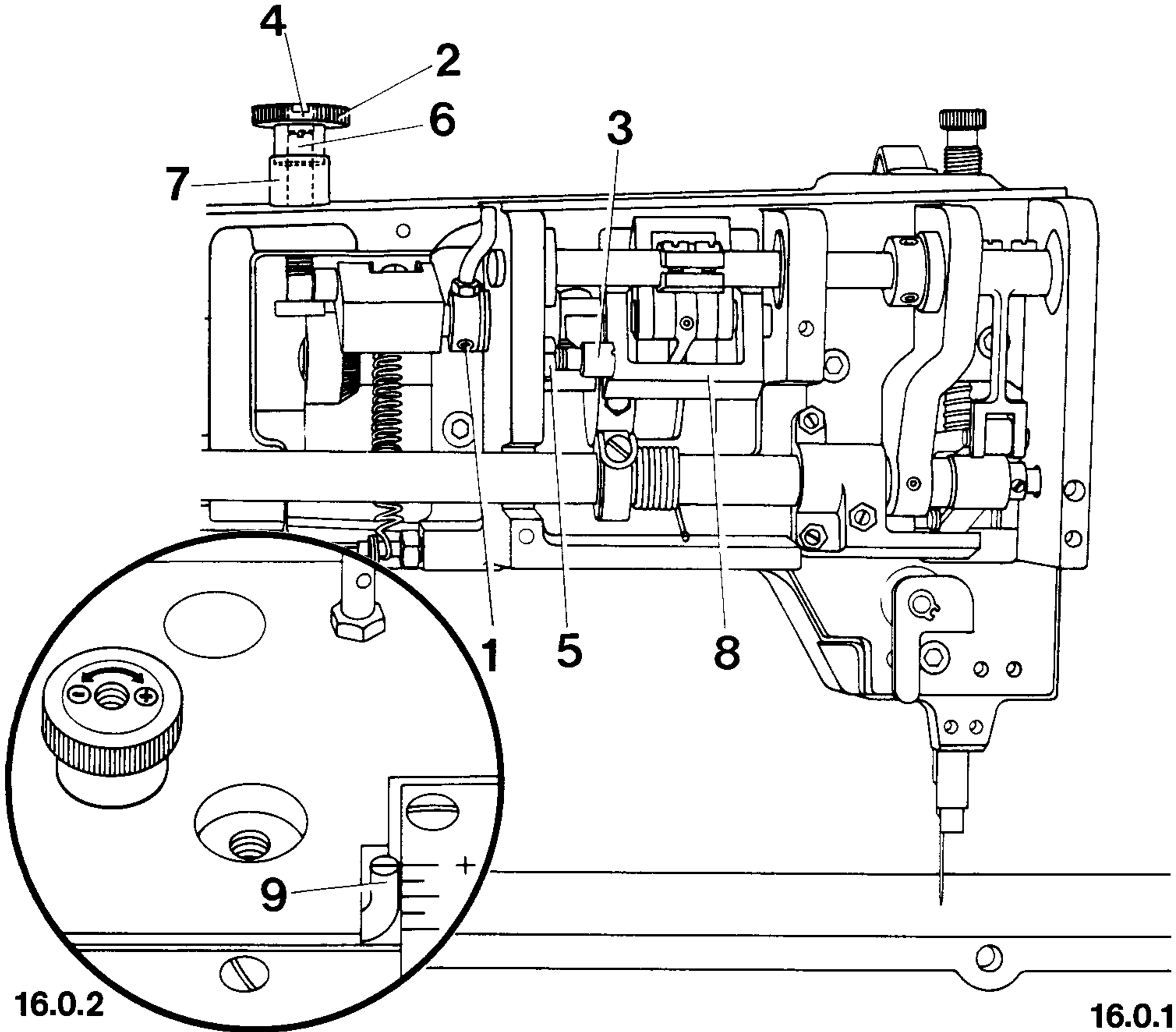

### 16.0.2

Adjustment:

- 16.1 Loosen screw 1.
- 16.2 Loosen nut 5 and turn eccentricity of eccentric 3 toward you.
- 16.3 **Turn in threaded pin 6 until the stroke of the presser foot is 7 mm when the balance wheel is turned.**
- 16.4 Turn in milled nut 2 so that it contacts sleeve 7.
- 16.5 Turn in allen screw 4 and lock it in place with milled nut 2.
- 16.6 Adjust eccentric 3 so that it rests against crank 8, and tighten nut 5.
- 16.7 **Turn pointer 9 so that its mark is opposite the "+" on the housing cover.**
- 16.8 Tighten screw 1.

### 16.0.1

17 **Stroke limitation on machines with -918/09**

Requirement:

With the cylinder plunger extended and milled nut 2 fully turned in, the presser foot stroke must be 4 mm when the balance wheel is turned. With the cylinder plunger retracted, the presser foot stroke must be 7 mm\* when the balance wheel is turned. With cylinder plunger retracted, the mark of pointer 11 must be opposite the “+” on the housing cover.

Note: \* At the factory, the maximum stroke is limited to 5.5 mm on eccentric 6. When setting a higher stroke, observe the maximum speed (see table on page 36).

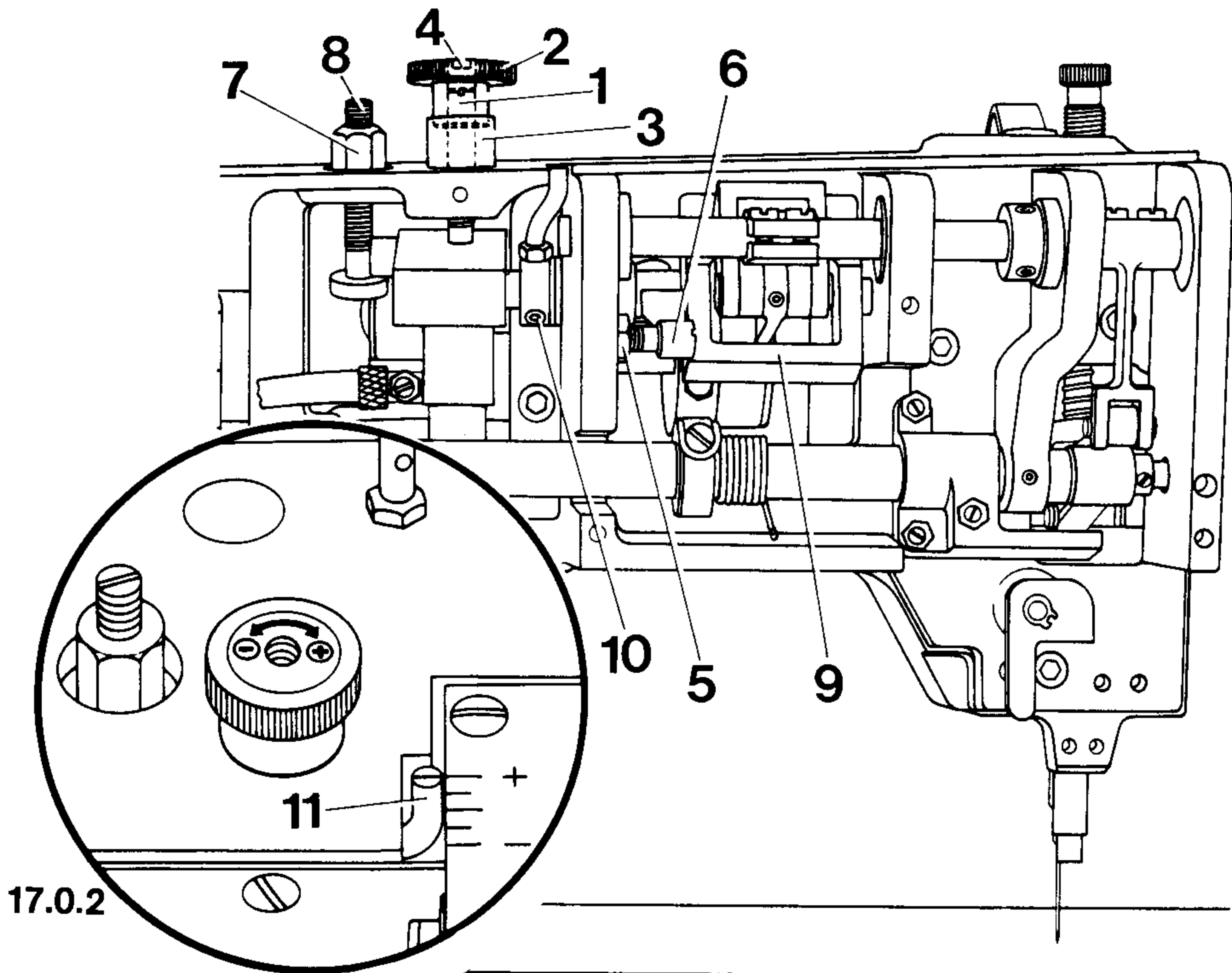

17.0.1

Adjustment:

- 17.1 Extend cylinder plunger.
- 17.2 **Turn in threaded pin 1 until the presser foot stroke is 4 mm when the balance wheel is turned.**
- 17.3 Turn in milled nut 2 so that it contacts sleeve 3.
- 17.4 Turn in allen screw 4 and lock in place with milled nut 2.
- 17.5 Loosen nut 5 and turn eccentricity of eccentric 6 toward you.
- 17.6 Loosen nut 7.
- 17.7 **Retract cylinder plunger and turn threaded pin 8 so that the presser foot stroke is 7 mm when the balance wheel is turned.**
- 17.8 In this position, lock threaded pin 8 in place with nut 7.
- 17.9 Adjust eccentric 6 so that it rests against crank 9, and tighten nut 5.
- 17.10 **Loosen screw 10 and turn pointer 11 so that its mark is opposite the “+” on the housing cover.**
- 17.11 Tighten screw 10.

Requirement:

With the presser foot stroke set at 3 mm, and the foot resting on the needle plate, the top feed dog must just have arrived at the needle plate when the needles on their way down are 3 mm above it.

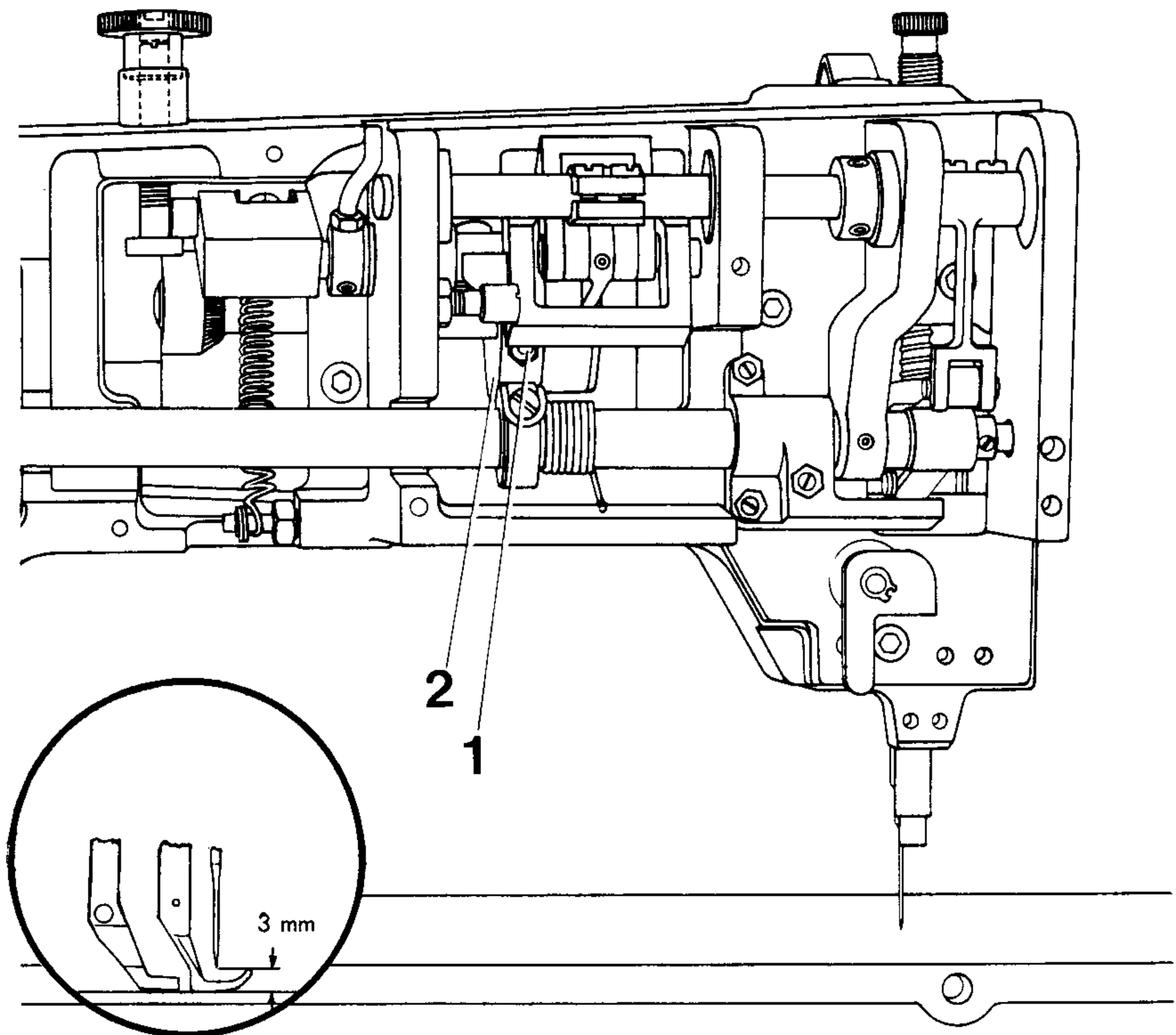

18.0.2

18.0.1

Adjustment:

- 18.1 Set the presser foot stroke at 3 mm.
- 18.2 Lower the foot onto the needle plate.
- 18.3 Loosen screws 1 until lifting eccentric 2 can be turned on the shaft against resistance.
- 18.4 Move lifting eccentric 2 until the top feed dog reaches the needle plate.
- 18.5 In this position, tighten screws 2.
- 18.6 Carry out a check (see "Requirement").

Requirement:

When the knee lever is operated it must have a slight play before the presser foot is raised.

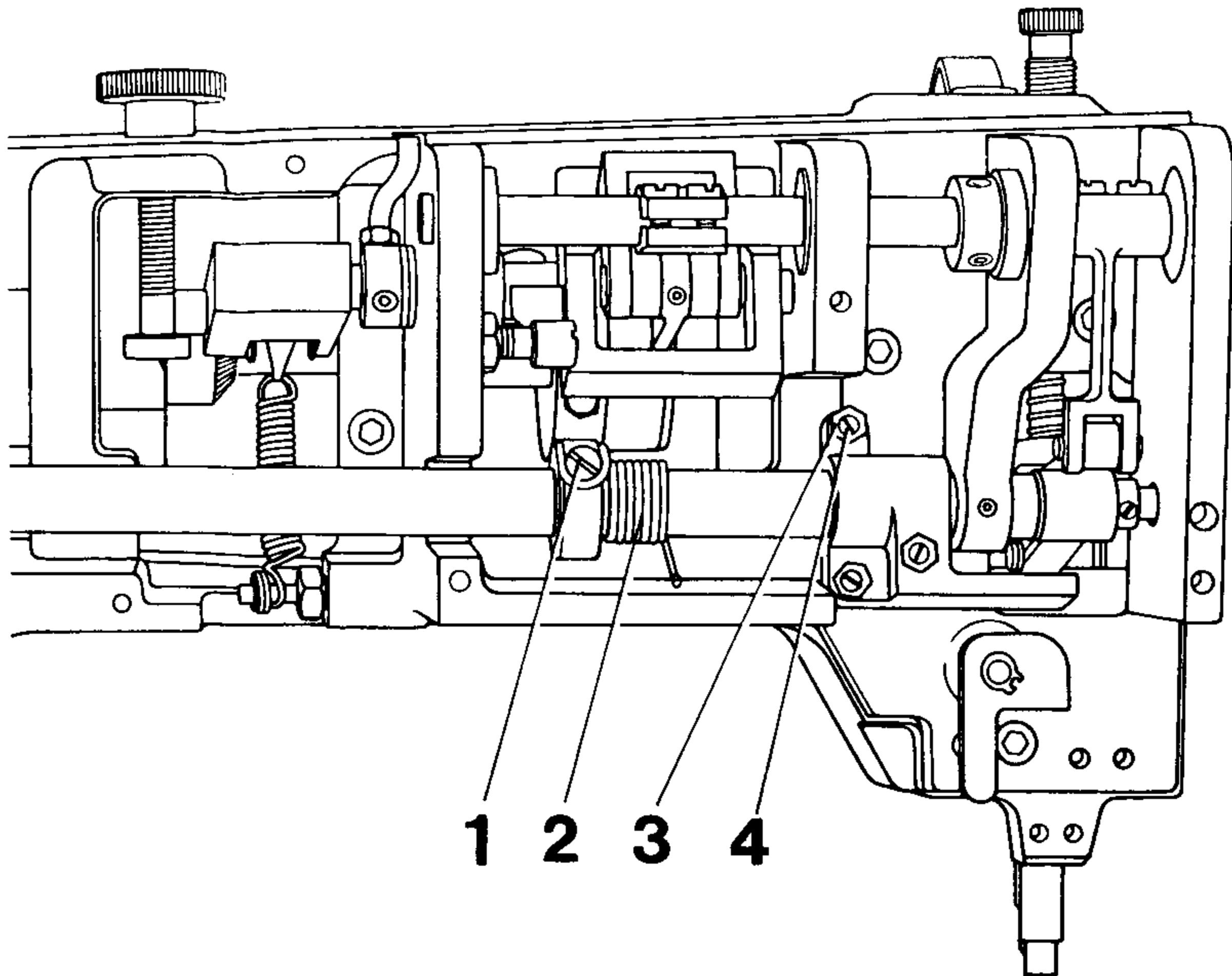

19.0.1

Adjustment:

- 19.1 Loosen screw 1 and set a tension of about half a turn on tension spring 2.
- 19.2 Tighten screw 1.
- 19.3 Place the knee-lever connection on the vertical shaft of the knee lever, push it up and turn it fully to the right.
- 19.4 Insert the knee lever into the knee-lever connection.
- 19.5 Lower the lifting presser onto the needle plate.
- 19.6 Loosen locknut 3 and unscrew stop screw 4 by a few turns.
- 19.7 Turn stop screw 6 back in until the lifting presser begins to rise from the needle plate.
- 19.8 **In this position turn stop screw 4 back half a turn and lock it with nut 3.**
- 19.9 Carry out a check (see "Requirement").

Requirement:

When the knee lever is fully actuated there must be a clearance of 11 or 14 mm between lifting presser and needle plate (see table).	
Machine version	Clearance
1445; 1446-.../...-900/56	11 mm
1445; 1446-.../...	14 mm
1445; 1446-.../...-900/56-913/08	14 mm

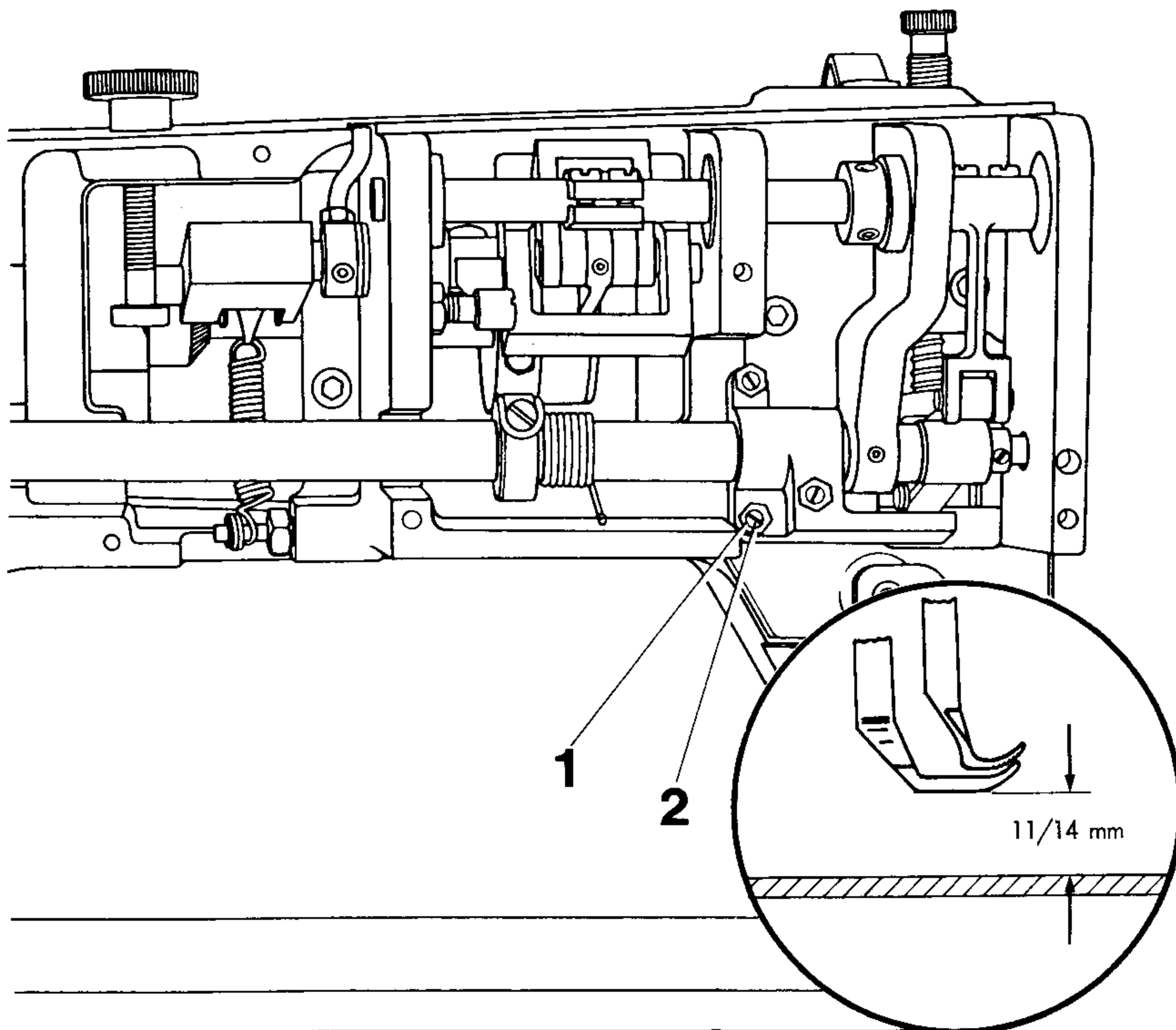

20.0.1

20.0.2

Adjustment:

- 20.1 Loosen nut 1.
- 20.2 **Fully actuate the knee lever and holding it there, turn threaded stud 2 so that there is a clearance of 11 or 14 mm between presser foot and needle plate.**
- 20.3 In this position lock threaded stud 2 with nut 1.
- 20.4 Carry out a check (see "Requirement").

Requirement:

Knee-lever connecting shaft 5 should be at an angle of  $15^\circ$  to the left of a line extending perpendicularly from the bedplate.

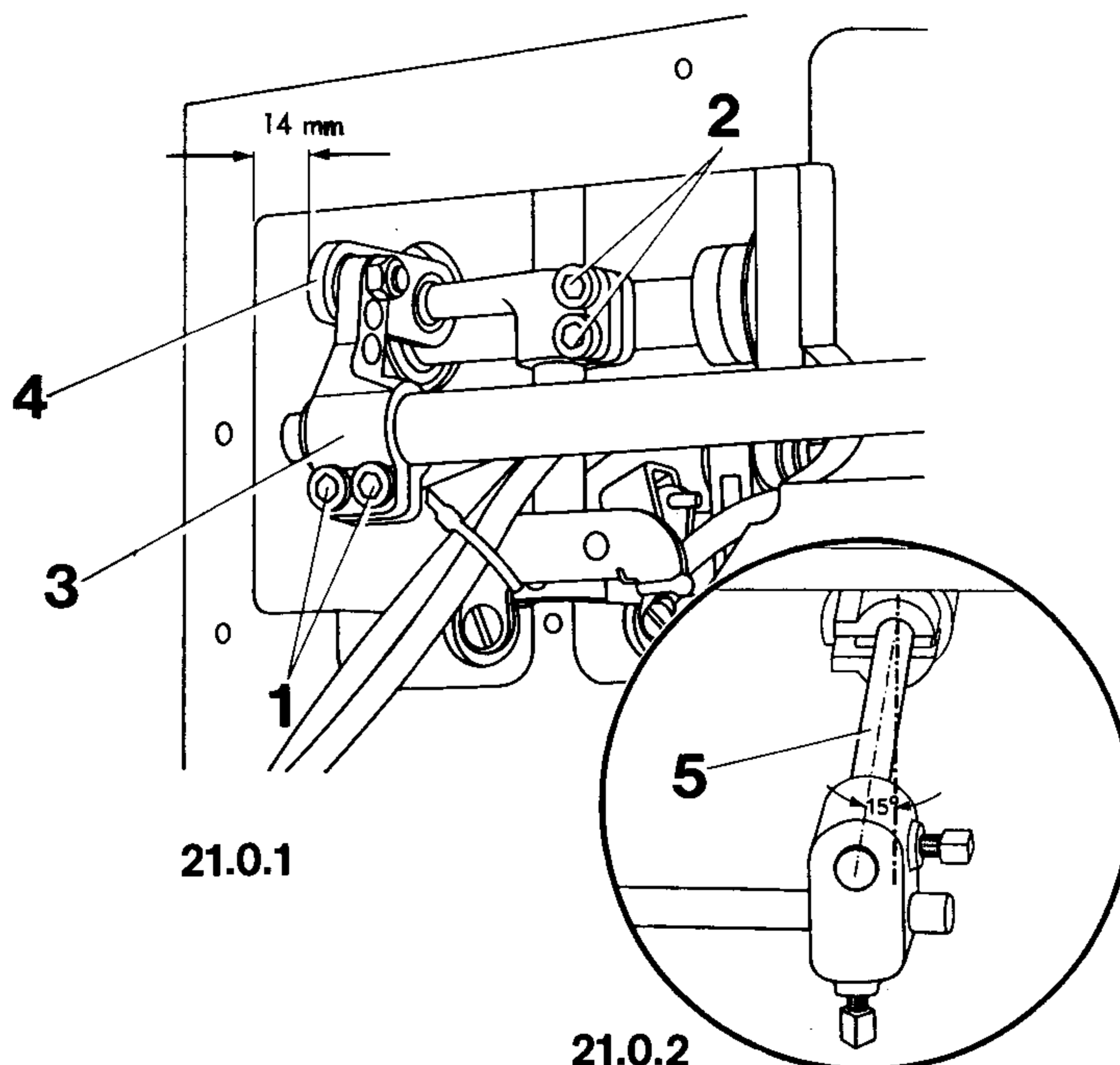

Adjustment:

- 21.1 Loosen screws 1 and 2.
- 21.2 Turn crank 3 so that the front edge of ball joint 4 stands back from the housing by roughly 14 mm.
- 21.3 Tighten screws 1.
- 21.4 **Making sure that ball joint 4 is positioned horizontal, set the knee lever so that the connecting shaft is at an angle of  $15^\circ$  to the left of a line extending perpendicularly from the bedplate (see Fig. 21.0.2).**
- 21.5 In this position tighten screws 2.

Requirement:

With the knee lever actuated the two tension discs must be opened by at least 0.5 mm.

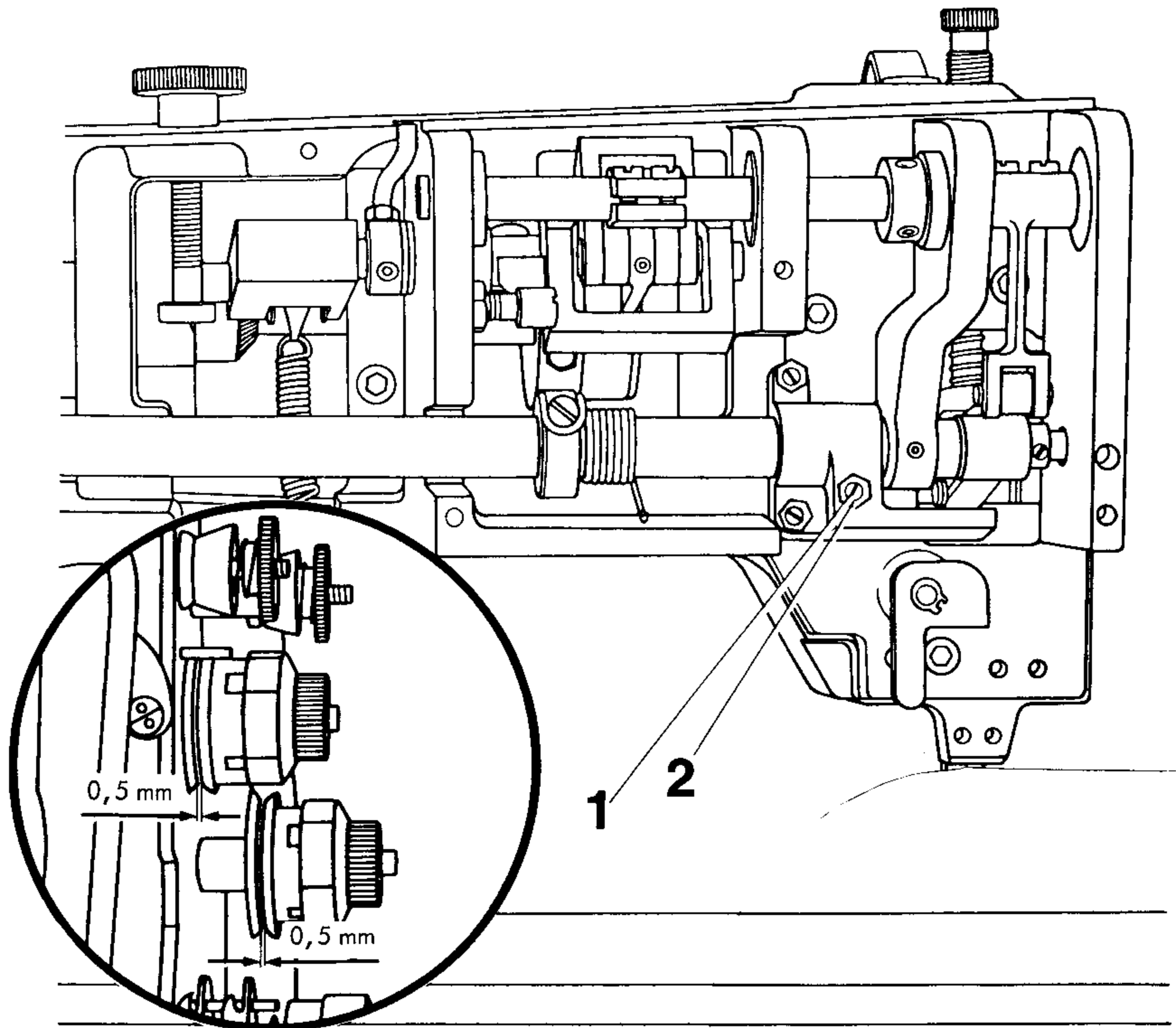

22.0.2

22.0.1

Adjustment:

- 22.1 Loosen nut **2** and unscrew threaded stud **1** a few turns.
- 22.2 Fully actuate the knee lever.
- 22.3 **Turn threaded stud 1 until the two tension discs are at least 0.5 mm apart.**
- 22.4 In this position lock threaded stud **1** with nut **2**.
- 22.5 Carry out a check (see "Requirement")



Requirement:

After the machine has run at full speed for about ten seconds, a fine trace of oil should appear opposite each hook on a piece of paper placed vertically behind them.

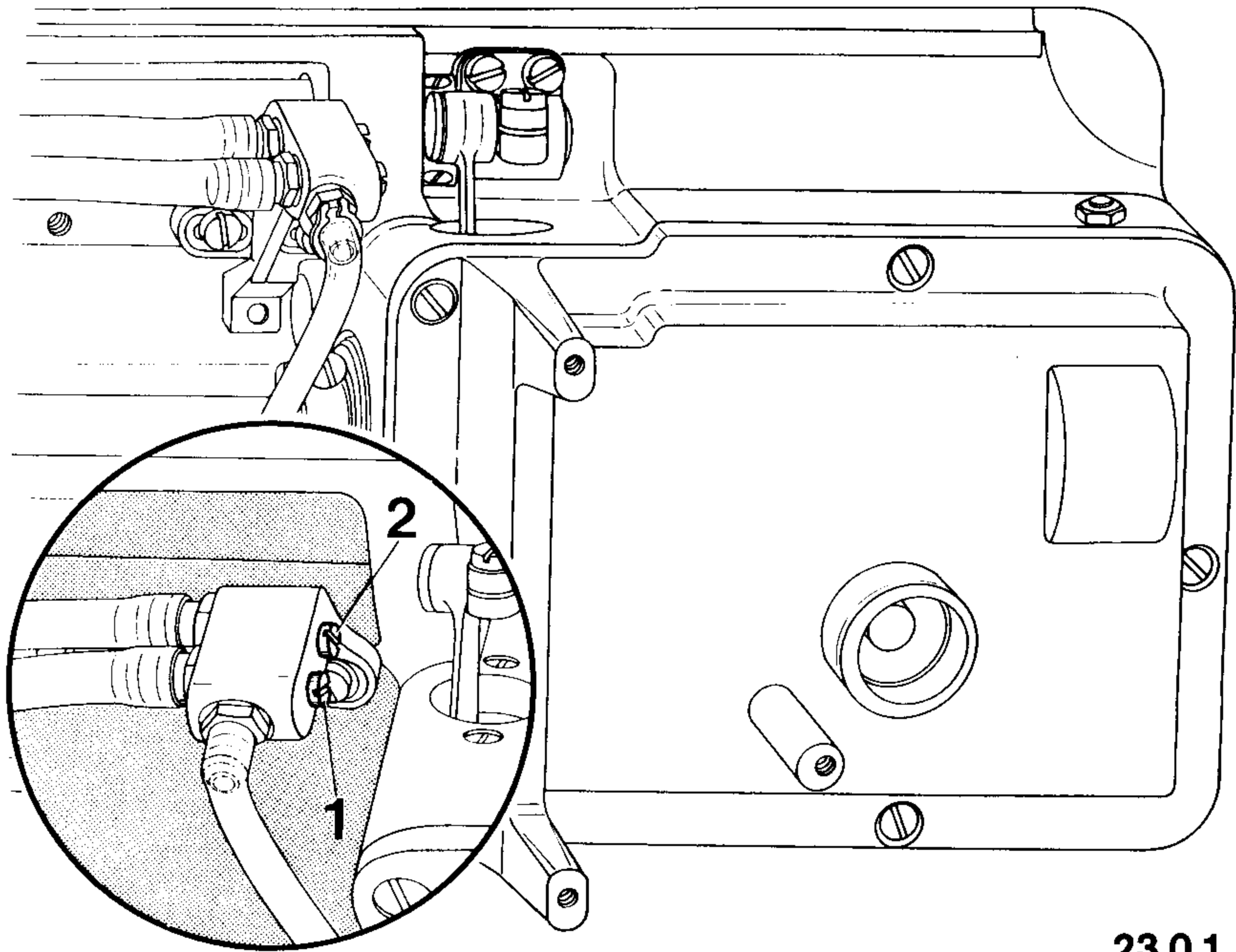

23.0.2

23.0.1

Adjustment:

- 23.1 Check the oil level at the oil sight glass and, if necessary, top up the reservoir until the oil level is in line with the upper mark. Use oil with a mean viscosity of 22.0 mm<sup>2</sup>/s at 40°C and a density of 0.865 g/cm<sup>3</sup> at 15°C. We recommend Pfaff sewing machine oil No. 280-1-120144.
- 23.2 Turn in regulating screws 1 and 2 of the oil check valve as far as they will go, and then back out by half a turn.
- 23.3 Turn on the master switch and let the machine run about one minute.
- 23.4 Place a piece of paper vertically behind the hooks. Then check to see if a fine trace of oil has appeared on the paper opposite each hook raceway.
- 23.5 **If too much oil is emitted, turn in regulating screw 1 for the right hook or 2 for the left hook somewhat. If too little oil is emitted, turn out the respective screw a little.**
- 23.6 Check this adjustment (see "Requirement")

Requirement:

When the bobbin winders are engaged, the winder spindles should be driven reliably; when the bobbin winders are disengaged, however, friction wheels 3 must not contact drive wheels 2. Furthermore, each bobbin winder should stop automatically when the thread wound on the bobbin has reached a point abt. 1.0 mm below its rim.

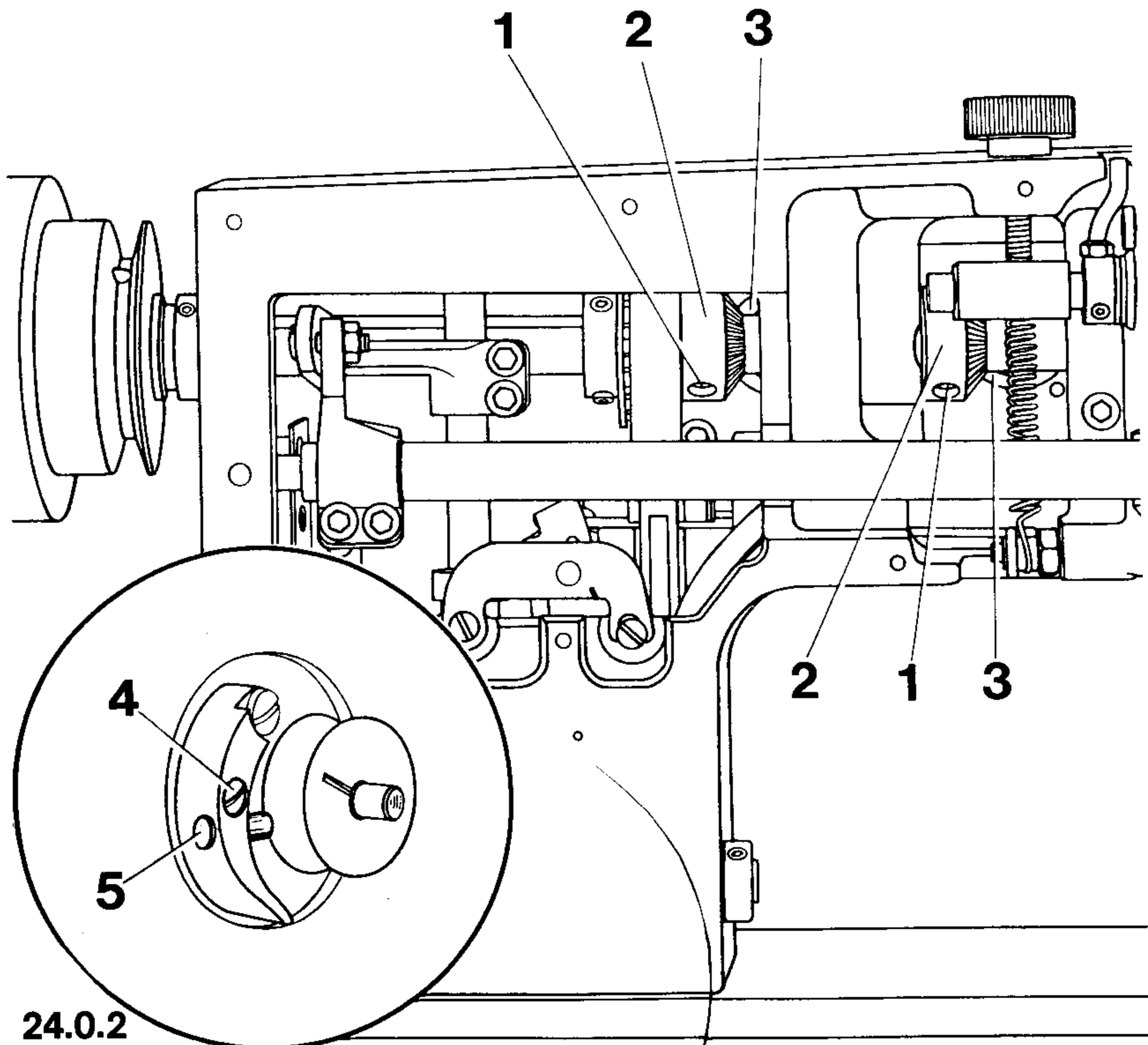

24.0.2

Adjustment:

24.0.1

- 24.1 Engage both bobbin winders.
- 24.2 Loosen screws 1 of both drive wheels which are accessible from the back of the machine arm.
- 24.3 Adjust the position of drive wheels 2 on the arm shaft so that both winder spindles will be driven reliably when the bobbin winders are engaged, but that friction wheels 3 will not be in contact with drive wheels 2 when the bobbin winders are disengaged.
- 24.4 In this position, tighten screws 1.
- 24.5 Loosen screw 4 of the right stop latch.
- 24.6 **If the bobbin is too full, push regulating stud 5 toward the right; if it is not full enough, push it toward the left.**
- 24.7 After the adjustment, tighten screw 4 again.
- 24.8 Repeat the same adjustment for the left bobbin winder.
- 24.9 Check this adjustment (see "Requirement").

Requirement:

The movement of the thread check springs must be completed when the needle point penetrates the material (roughly 7 mm stroke).

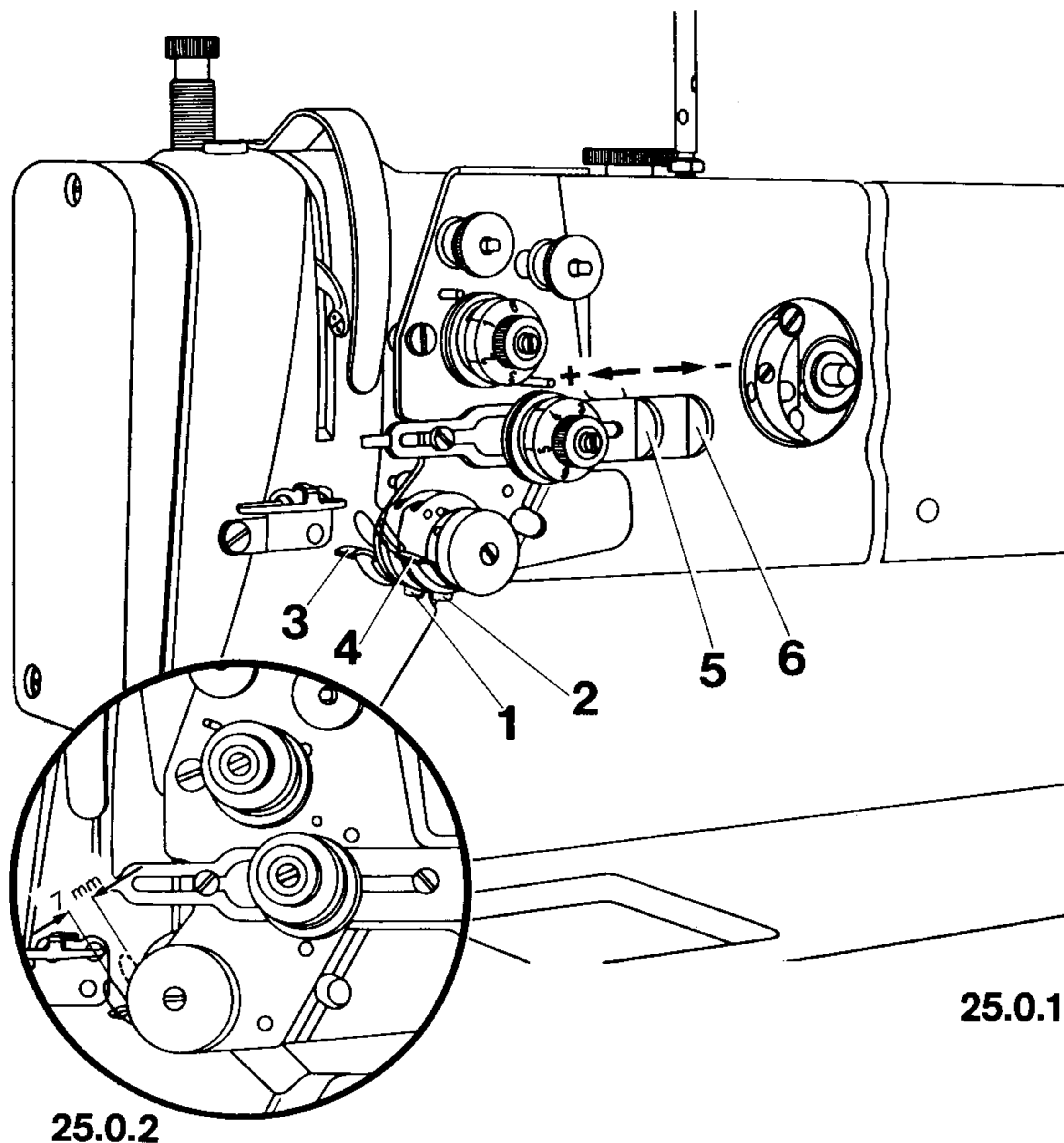

Adjustment:

- 25.1 Thread the machine and place a piece of waste fabric under the presser foot.
- 25.2 Lower the presser foot onto the needle plate.
- 25.3 Loosen screws 1 and 2 of stops 3 and 4.
- 25.4 Make a number of stitches by turning the balance wheel, then set the take-up lever at top dead centre.
- 25.5 Continue turning the balance wheel in rotating direction and allow the thread check springs to move back by 7 mm.
- 25.6 In this position move stops 3 and 4 up against the thread check springs and tighten screws 1 and 2.
- 25.7 Carry out a check (see "Requirement").

Note: When the thread is passed around the sewing hook the check spring should just make a brief movement. This is adjusted by re-setting the position of thread regulators 5 and 6. Move towards "+" for more thread and towards "-" for less thread.

**Maximum speeds**

<b>Class 1445</b>	
Top feed lift	Max. speed in s.p.m.
7 mm	2000
6 mm	2300
5 mm	2700
4 mm	3000
3 mm	3400
2 mm	3800
1 mm	4000

<b>Class 1446</b>					
Top feed lift	Max. speed in s.p.m. for needle gauges				
	Up to 6 mm	Up to 12 mm	Up to 20 mm	Up to 28 mm	Up to 40 mm
7 mm	1800	1700	1600	1500	1400
6 mm	2000	1900	1800	1700	1600
5 mm	2300	2150	2000	1900	1800
4 mm	2700	2500	2300	2150	2000
3 mm	3000	2850	2700	2500	2300
2 mm	3400	3200	3000	2850	2700
1 mm	3800	3600	3400	3200	3000

**Quick-change stepping control -918/09**

By this control the maximum speed is decreased automatically when the machine is switched over to high stroke, and increased in case of low stroke.

The speed to be used for low stroke is determined by the V-belt pulley on the motor shaft. The speed for high stroke is set at potentiometer **11** on the motor control box of the Efka-Variostop motor 5 G 32D-03 and at potentiometer **7** on the control box of motor 5 G43 P 456.

**After-braking action**

When using electronic stop motors, make sure they have an after-braking action.

Electronic stop motors type Efka – VD 552-5 G 43, VD 552-5 G 43 VP 456 and Quick – NDK 880/12-25 621, NDK 880/12-25 321 are equipped with this feature.

The after-braking action serves to secure the position of the take-up lever at top dead centre after thread trimming. Make sure the balance wheel can still be turned by hand. Adjustment is made at the motor control box (refer to adjustment instructions of motor manufacturer).

Requirement:

With the presser foot at its highest position, the needle point must not protrude under the presser foot.

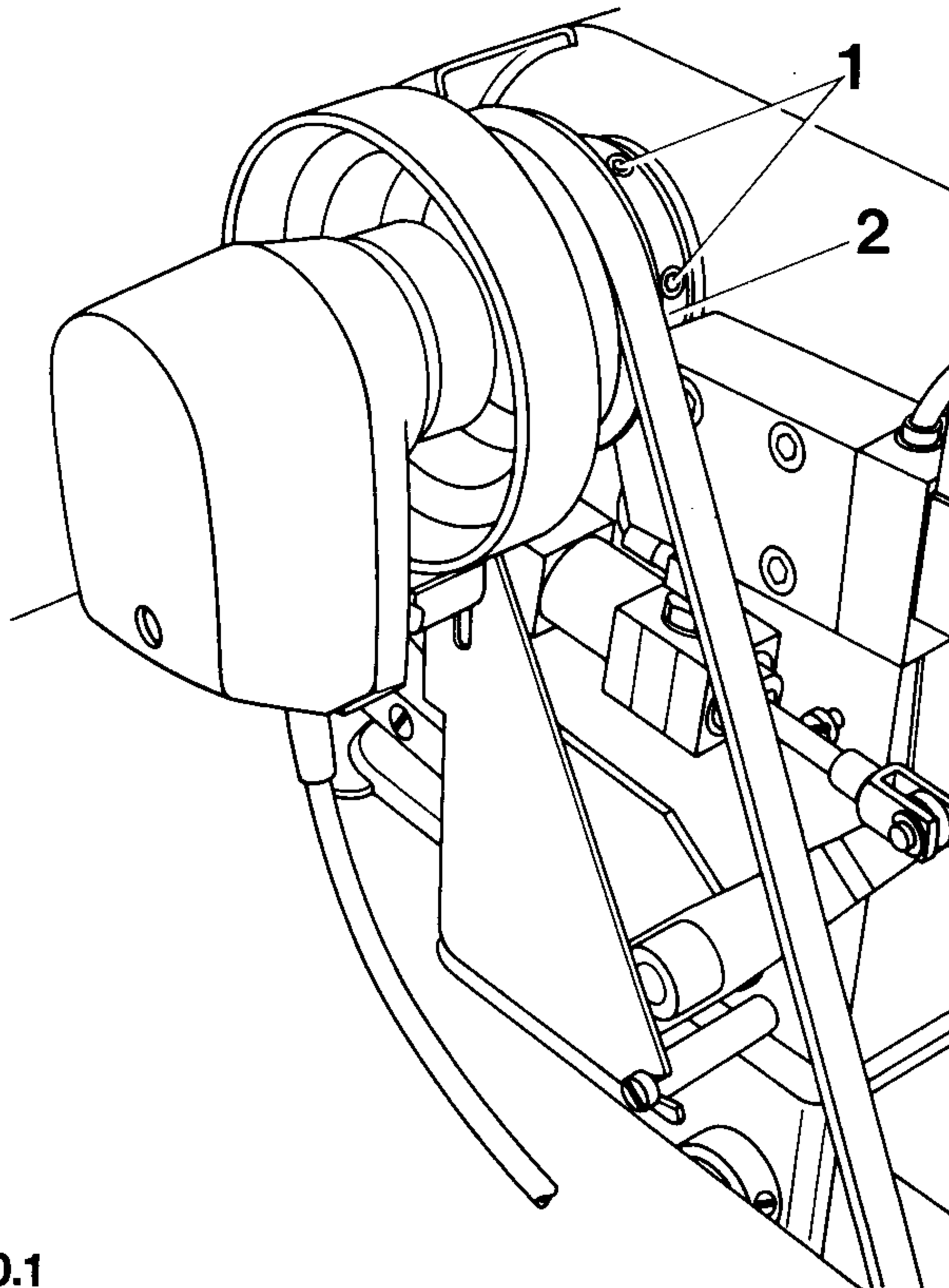

### 29.0.1

Adjustment:

- 29.1 Loosen screws 1.
- 29.2 Turn retaining collar 2 so that the needle point does not protrude from under the presser foot when the presser foot is at its highest position.
- 29.3 Tighten screws 1.
- 29.4 Carry out a check (see "Requirement"), re-adjust, if necessary.

