

PFAFF

937

Instruction Manual



This instruction manual is valid for all models and subclasses listed in the chapter "**Specification**".

The reprinting, copying or translation of PFAFF Instruction Manuals, whether in whole or in part, is only permitted with our previous permission and with written reference to the source.

G.M. PFAFF
Aktiengesellschaft

Postfach 3020
D-67653 Kaiserslautern

Königstr. 154
D-67655 Kaiserslautern

Redaktion / Illustration
HAAS-Publikationen GmbH
D-53840 Troisdorf

	Contents	Chapter -Page
1	Safety	1 - 1
1.01	Directives	1 - 1
1.02	General notes on safety	1 - 1
1.03	Safety symbols	1 - 1
1.04	Important points for the user	1 - 2
1.05	Operating and specialist personnel	1 - 2
1.05.01	Operating personnel	1 - 2
1.05.02	Specialist personnel	1 - 2
1.06	Danger	1 - 3
2	Proper use	2 - 1
3	Specifications	3 - 1
3.01	PFAFF 937	3 - 1
3.02	Models and subclasses	3 - 2
3.03	Needle and thread	3 - 2
4	Disposal of machine waste	4 - 1
5	Transport, packaging and storage	5 - 1
5.01	Transport to the customer's premises	5 - 1
5.02	Transport within the customer's premises	5 - 1
5.03	Disposal of the packaging	5 - 1
5.04	Storage	5 - 1
6	Explanation of the symbols	6 - 1
7	Operational controls	7 - 1
7.01	On/Off switch	7 - 1
7.02	Knuckle switch on machine head	7 - 1
7.03	Pedal	7 - 2
7.04	Presser foot lifter	7 - 2
7.05	Adjustment lever for zigzag stitch and needle position	7 - 3
7.06	Reverse-feed key	7 - 3
7.07	Stitch-length adjustment wheel	7 - 4
7.08	Adjustment wheels for the top feed	7 - 4
8	Installation and commissioning	8 - 1
8.01	Installation	8 - 1
8.01.01	Adjusting the height of the table top	8 - 1
8.01.02	Tightening the V-belt	8 - 2
8.01.03	Mounting the upper V-belt guard	8 - 2
8.01.04	Fitting the lower V-belt guard	8 - 3
8.01.05	Mounting the reel stand and the sewing lamp	8 - 3
8.02	Commissioning	8 - 1
8.03	Switching the machine on/off	8 - 4

	Contents	Chapter- Page
9	Preparation	9 - 1
9.01	Inserting the needle	9 - 1
9.02	Winding the bobbin thread, adjusting the thread tension	9 - 2
9.03	Removing/inserting the bobbin case	9 - 3
9.04	Threading the bobbin case, adjusting the thread tension	9 - 3
9.04.01	PFAFF 937 without thread trimmer -900/..	9 - 3
9.04.02	PFAFF 937 with thread trimmer -900/..	9 - 4
9.05	Threading the needle thread	9 - 5
9.06	Adjusting the needle-thread tension	9 - 5
9.07	Adjusting the zigzag stitch and needle position	9 - 6
9.08	Adjusting the stitch length	9 - 6
9.09	Adjusting the top feed	9 - 7
9.09.01	Normal sewing	9 - 7
9.09.02	Applying fullness constantly	9 - 8
9.09.03	Applying fullness intermittently	9 - 9
9.09.04	Constant braking of the top fabric ply (stretching)	9 - 10
9.09.05	Braking the top fabric ply or intermittently applying fullness	9 - 11
10	Care and maintenance	10 - 1
10.01	Cleaning	10 - 1
10.02	Lubricating the hook	10 - 2
10.03	Lubricating the zigzag drive	10 - 2
10.04	Checking the air pressure	10 - 4
10.05	Emptying/cleaning the water container of the air filter/regulator	10 - 4
11	Adjustment	11 - 1
11.01	Notes on adjusting	11 - 1
11.02	Tools, gauges and other accessories	11 - 1
11.03	Abbreviations	11 - 1
11.04	Check and adjustment aid	11 - 2
11.05	Adjusting the basic machine	11 - 3
11.05.01	Balancing weight	11 - 3
11.05.02	Centering the needle in the needle hole (in sewing direction)	11 - 4
11.05.03	Parallel guiding of the needle bar	11 - 5
11.05.04	Locking lever	11 - 6
11.05.05	Zero stitch and zigzag stitch scale	11 - 7
11.05.06	Centering the needle in the needle hole (across sewing-direction)	11 - 8
11.05.07	Zigzag stitch width	11 - 9
11.05.08	Zigzag stitch motion	11 - 10
11.05.09	Needle penetration symmetry	11 - 11
11.05.10	Needle position adjustment lever	11 - 12
11.05.11	Adjustment wheels for applying fullness	11 - 13
11.05.12	Zeroing the differentiation	11 - 14
11.05.13	Main-stitch-length display	11 - 15
11.05.14	Zeroing the bottom feed (with gearbox housing closed)	11 - 16
11.05.15	Zeroing the bottom feed (with gearbox housing open)	11 - 17
11.05.16	Vibrating presser connecting rod	11 - 18

Contents		Chapter - Page
11.05.17	Zeroing the vibrating presser	11 - 19
11.05.18	Torsion spring of the reverse feed lever	11 - 20
11.05.19	Torsion spring of the differentiation regulating shaft	11 - 21
11.05.20	Feeding motion of the bottom feed dog	11 - 22
11.05.21	Lifting motion of the bottom feed dog	11 - 23
11.05.22	Drive belt in the gearbox housing	11 - 24
11.05.23	Hook bearing bracket	11 - 25
11.05.24	Hook lubrication	11 - 26
11.05.25	Pre-adjusting the needle height	11 - 27
11.05.26	Needle rise, hook-to-needle clearance and bobbin case positioning-finger	11 - 28
11.05.27	Final adjustment of the needle height	11 - 29
11.05.28	Bobbin case opener position	11 - 30
11.05.29	Bobbin case opener motion	11 - 31
11.05.30	Bottom-feed dog height	11 - 32
11.05.31	Clearance between presser foot and needle plate	11 - 33
11.05.32	Vibrating-presser feed and connecting lever	11 - 35
11.05.33	Vibrating-presser stroke	11 - 37
11.05.34	Vibrating-presser lifting motion	11 - 38
11.05.35	Vibrating-presser feeding motion	11 - 39
11.05.36	Feeding motion difference	11 - 40
11.05.37	Vibrating presser and presser foot pressure	11 - 41
11.05.38	Thread diverter pin	11 - 42
11.05.39	Needle-thread tension release (machines without -900/..)	11 - 43
11.05.40	Limiting the knee lever stroke	11 - 44
11.05.41	Knee lever play	11 - 45
11.05.42	Bobbin winder	11 - 46
11.06	Adjusting the thread trimmer -900/51	11 - 47
11.06.01	Pre-adjusting the control cam	11 - 47
11.06.02	Roller lever	11 - 48
11.06.03	Pawl	11 - 49
11.06.04	Engaging solenoid	11 - 50
11.06.05	Release lever	11 - 51
11.06.06	Engaging lever	11 - 52
11.06.07	Thread catcher position and cutting test	11 - 53
11.06.08	Control cam (final adjustment) and retaining spring	11 - 54
11.06.09	Needle-thread tension release	11 - 55
11.06.10	Removing and refitting the control unit	11 - 57
11.06.11	Synchronizer	11 - 58

1 Safety

1.01 Directives

This machine is constructed in accordance with the European regulations contained in the conformity and manufacturer's declarations

In addition to this Instruction Manual, observe also all generally accepted, statutory and other regulations and legal requirements and all valid environmental protection regulations! The regionally valid regulations of the social insurance society for occupational accidents or other supervisory organisations are to be strictly adhered to!

1.02 General notes on safety

- This machine may only be operated by adequately trained operators and only after having completely read and understood the Instruction Manual!
- All Notes on Safety and Instruction Manuals of the motor manufacturer are to be read before operating the machine!
- The danger and safety instructions on the machine itself are to be followed!
- This machine may only be used for the purpose for which it is intended and may not be operated without its safety devices. All safety regulations relevant to its operation are to be adhered to.
- When exchanging sewing tools (e.g. needle, presser foot, needle plate, feed dog or bobbin), when threading the machine, when leaving the machine unattended and during maintenance work, the machine is to be separated from the power supply by switching off the On/Off switch or by removing the plug from the mains!
- Everyday maintenance work is only to be carried out by appropriately trained personnel!
- Repairs and special maintenance work may only be carried out by qualified service staff or appropriately trained personnel!
- When servicing or carrying out repairs on pneumatic devices, the machine is to be removed from the compressed air supply! The only exceptions to this are adjustments and function checks carried out by appropriately trained personnel!
- Work on electrical equipment may only be carried out by appropriately trained personnel!
- Work is not permitted on parts and equipment which are connected to the power supply! Exceptions to this are only to be found in the regulations EN 50110.
- Modifications and alterations to the machine may only be carried out under observance of all the relevant safety regulations!
- Only spare parts which have been approved by us are to be used for repairs! We expressly point out that any replacement parts or accessories which are not supplied by us have not been tested and approved by us. The installation and/or use of any such products can lead to negative changes in the structural characteristics of the machine. We shall not be liable for any damage which may be caused by non-original parts.

1.03 Safety symbols



Danger!
Points to be observed.



Danger of injury for operating and specialist personnel!

1.04 Important points for the user

- This Instruction Manual is a component part of the machine and must be available to the operating personnel at all times.
- The Instruction Manual must be read before operating the machine for the first time.
- The operating and specialist personnel is to be instructed as to the safety equipment of the machine and regarding safe work methods.
- It is the duty of the operator to only operate the machine in perfect running order.
- It is the obligation of the operator to ensure that none of the safety mechanisms are removed or deactivated.
- It is the obligation of the operator to ensure that only authorized persons operate and work on the machine.

Further information can be obtained at your PFAFF agent.

1.05 Operating and specialist personnel

1.05.01 Operating personnel

Operating personnel are persons responsible for the equipping, operating and cleaning of the machine as well as taking care of faults arising in the sewing area.

The operating personnel is obliged to observe the following points and must:

- always observe the Notes on Safety in the Instruction Manual!
- never use any working methods which could limit the level of safety in using the machine!
- not wear loose-fitting clothing or jewellery such as chains or rings!
- also ensure that only authorized persons have access to the potentially dangerous area around the machine!
- always immediately report to the person responsible any changes in the machine which may limit its safety!

1.05.02 Specialist personnel

Specialist personnel are persons with a specialist education in the fields of electrics, electronics and mechanics. They are responsible for the lubrication, maintenance, repair and adjustment of the machine.

The specialist personnel is obliged to observe the following points and must:

- always observe the Notes on Safety in the Instruction Manual!
- switch off the On/Off switch before carrying out adjustments or repairs and ensure that it cannot be switched on again unintentionally!
- never work on parts which are still connected to the power supply! Exceptions are contained only in the regulations EN 50110.
- when servicing or carrying out repairs on pneumatic devices, remove the machine from the compressed air supply! The only exceptions to this are function checks.
- replace the protective coverings and close the electrical control box after all repairs or maintenance work!

1.06

Danger



A working area of 1 meter is to be kept free both in front of and behind the machine while it is in operation so that it is always easily accessible.



Never reach into the sewing area while sewing! Danger of injury by the needle!



Never leave objects on the table or in the needle plate area while adjusting the machine settings! Objects can become trapped or be slung away! Danger of injury!



Always wait for the motor to stop before working on mechanically actuated clutch-motors without an operating lock! Danger of injury!

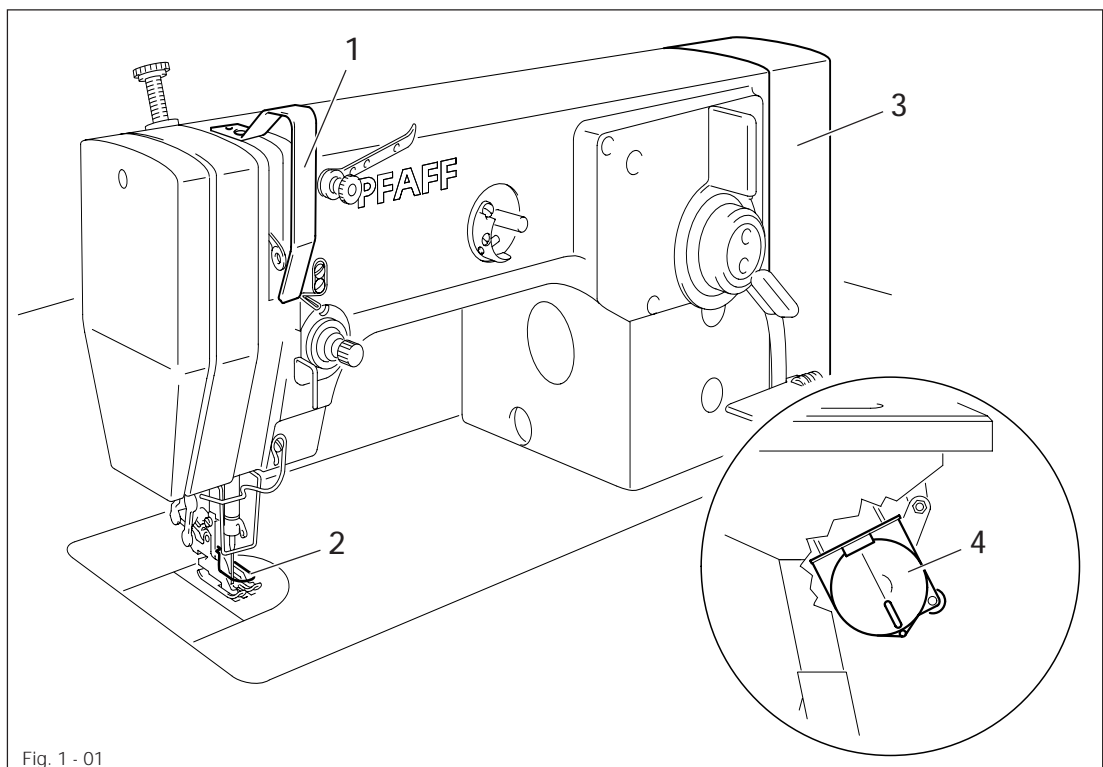

Fig. 1 - 01



Do not operate the machine without its take-up-lever guard 1!
Danger of injury due to the motion of the take-up lever!



Do not operate the machine without its finger guard 2!
Danger of injury due to the up and down motion of the needle!



Do not operate the machine without its belt guards 3 and 4!
Danger of injury due to the rotating V-belt!

2 **Proper use**

The PFAFF 937 is a high-performance high-speed zigzag sewing machine with bottom feed and an adjustable top feed.

These machines are designed for producing topstitch zigzag seams in the apparel and linen goods industries.



Any and all uses of these machines which have not been approved of by the manufacturer are considered to be inappropriate! The manufacturer cannot be held liable for any damaged caused by the inappropriate use of the machines! The appropriate use of the machines includes the observance of all operational, adjustment, maintenance and repair measures required by the manufacturer!

Specifications

3 Specifications

3.01 PFAFF 937

Stitch types: 301 (lockstitch)
304 (zigzag lockstitch)

Models: A and B

Needle system:

Top-feed model -706/81: 438

Top-feed model -706/83: 438-35

Needle thickness (Nm) in 1/100 mm:

Model A: 60 - 70

Model B: 80 - 100

Effective diameter of handwheel: 65 mm

Clearance under the presser foot: 7 to 9 mm

Fabric clearance width: 260 mm

Fabric clearance height: 130 mm

Dimensions of machine head:

Length: approx. 550 mm

Width: approx. 180 mm

Height (above table): approx. 230 mm

Working air pressure [▲]: 6 bar

Air consumption [▲]: ~0.8 l / work cycle

Working noise level:

Emission at workplace at sewing speed of n = 4000 spm: 80 dB(A)
(noise measurement in accordance with DIN 45 635-48-A-1)

Net weight of machine head: approx. 48 kg

[▲] Only on machines with pneumatic equipment
Gross weight of machine head: approx. 56 kg

3.02 Models and subclasses

	Model	Stitch-length name	Subclasses	Zigzag-stitch width	Max. stitch length in mm	Max. stitch length [♦] on -706/81	Max. stitch length [♦] on -706/83
PFAFF 937	A	-	-6/61	6.0	4.5	5000	4200
		-	-6/61-914/89	6.0	4.5	1600	-
	B	-	-6/61	6.0	4.5	5000	4200
		-	-6/61-914/89	6.0	4.5	1600	1600
		N 2,5	-3/83	2.0	2.5	5000	4200
		N 24	-6/41 ; 32/23	6.0	2.5	5000	4200

♦ Dependent on material and work phase

N 24 = 2.5 mm feeding stroke of the bottom feed

= 4.5 mm feeding stroke of the bottom feed

3.03 Needle and thread

Model	Use	Needle thickness (Nm) in 1/100 mm	Max. thread thickness (Nm) max. synthetic [▲]
A	For fine materials	60 to 70	60/3
B	For medium materials	80 to 100	40/3

▲ or comparable thicknesses of other thread types

4 Disposal of machine waste

- The proper disposal of machine waste is the responsibility of the customer.
- The materials used on the machines are steel, aluminium, brass and various plastics. The electrical equipment consists of plastics and copper.
- The machine waste is to be disposed of in accordance with the locally valid environmental protection regulations. If necessary a specialist is to be commissioned.



Special care is to be taken that parts soiled with lubricants are separately disposed of in accordance with the locally valid pollution control regulations!

5 Transport packaging and storage

5.01 Transport to the customer's premises

Within the Federal Republic of Germany, the complete machine (with table and motor) is delivered without packaging.

Machines without table and motor (only machine heads) and machines for export are packaged.

5.02 Transport within the customer's premises

The manufacturer carries no liability for transport within the customer's premises. Care is to be taken to transport the machine in an upright position.

5.03 Disposal of the packaging

The packaging of the machine consists of wood, paper, cardboard and VCE fibre. The proper disposal of the packaging is the responsibility of the customer.

5.04 Storage

The machine can be stored for up to 6 months if not in use. During this time it should be protected from dust and moisture.

For longer storage the individual parts of the machine, especially the moving parts, should be protected against corrosion e.g. by a film of oil.

Explanation of the symbols

6 Explanation of the symbols

In the following section of this Instruction Manual, certain tasks or important pieces of information are accentuated by symbols.

The symbols used have the following meanings:



Note, information



Cleaning, care



Lubrication, greasing

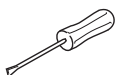

Servicing, repairing, adjustment, maintenance
(only to be carried out by specialist personnel)

7 Operational controls

7.01 On/Off switch

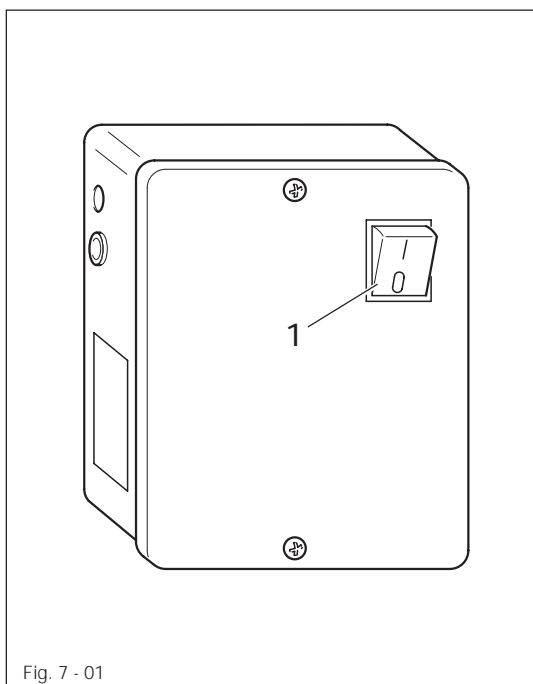

- Turn the machine on and off by pressing the On/Off switch 1 to "1" for on and "0" for off. When the machine is on, the control lamp 1 in the switch is lit.



The On/Off switch in the illustration is that of machines with Quick motors. When using other motors, other switches may be used.

7.02 Knuckle switch on machine head

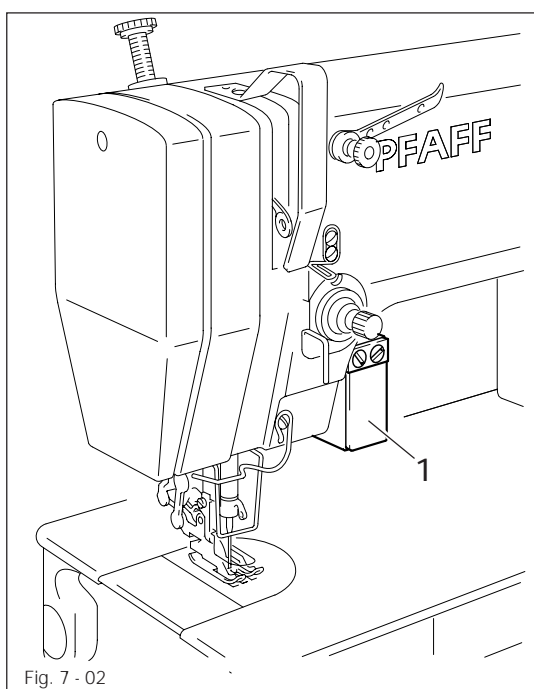

- Key 1 is for reversing the sewing direction (on machines with backtacker -911/35).

7.03 Pedal

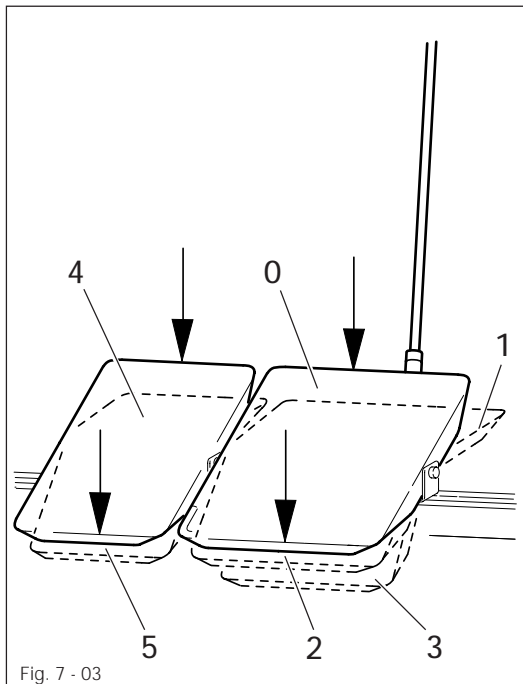

- 0 = Resting position
- 1 = Sew
- 2 = Lift presser-foot (on machines with automatic presser-foot lifter)
- 3 = Trim thread (on machines with a thread trimmer)
- 4+1 = Call up the second top-feed setting
- 5 = Reverse sewing



Further function-combinations can be found in the instruction manual of the motor manufacturer.

7.04 Presser foot lifter

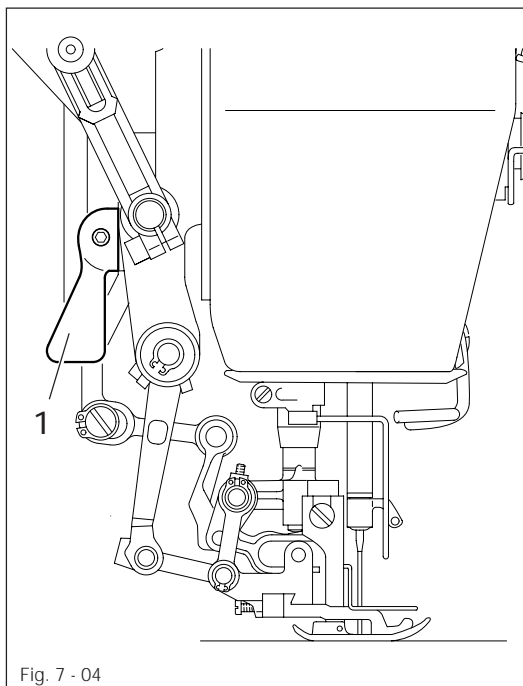

- The presser foot can be raised by turning lever 1.

7.05 Adjustment lever for zigzag stitch and needle position

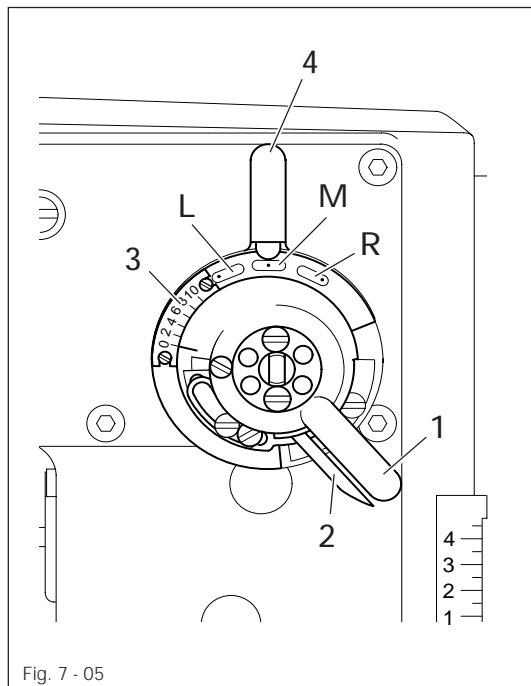

- The zigzag stitch adjustment lever 1 is used for adjusting the width of the zigzag stitch.
- To change the position of the adjustment lever, the locking lever 2 must be pressed against the adjustment lever 1.



The current zigzag-stitch width can be seen on scale 3.

- By turning the needle-position adjustment lever 4 the required needle position can be set.

- L = needle-position left
- M = needle-position center
- R = needle-position right

7.06 Reverse-feed key

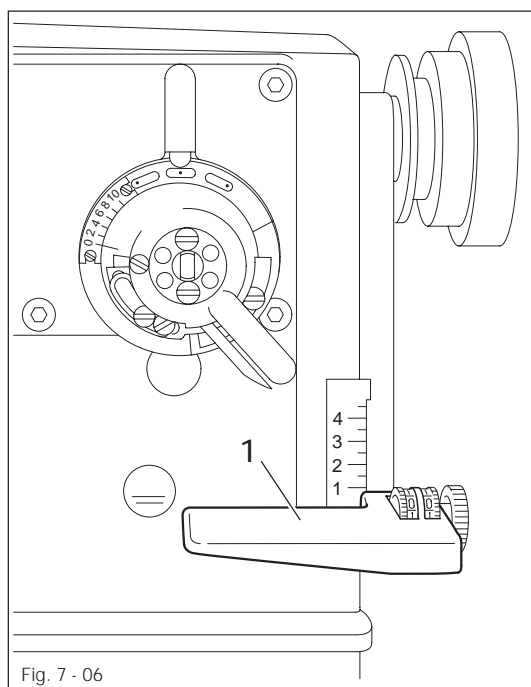

- The machine sews in reverse as long as the reverse-feed key 1 is pressed.

7.07 Stitch-length adjustment wheel

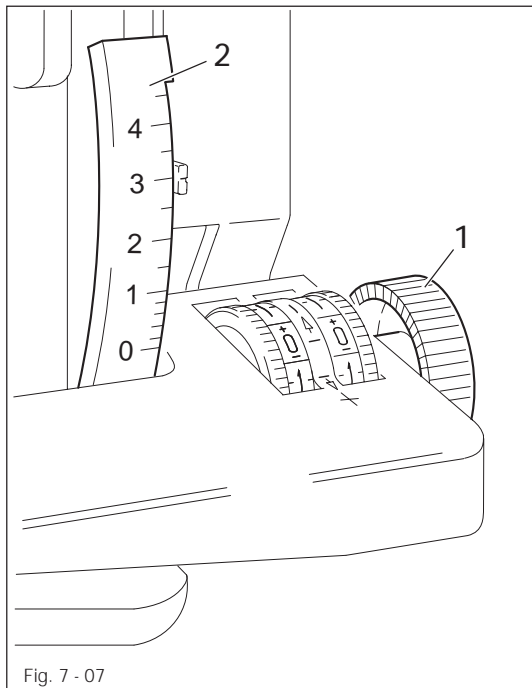

- The stitch length can be altered by turning the stitch-length adjustment wheel 1.



The current stitch-length can be seen on scale 2.

7.08 Adjustment wheels for the top feed

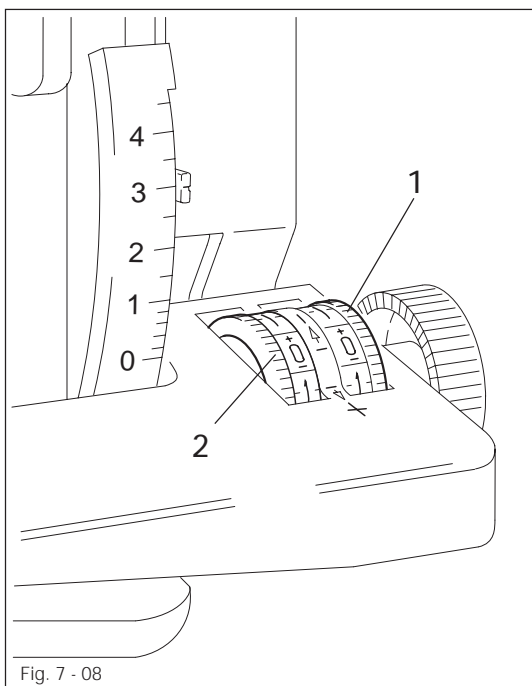

- Adjustment wheel 1 (1st setting)
This adjustment wheel is for adjusting the setting with which the machine is to do most of its work.

Green area	=	Apply fullness
Red area	=	Stretch
Zero	=	Normal sewing (top and bottom feeds work with same feed motion)

- Adjustment wheel 2 (2nd setting)
This adjustment wheel is for setting a value which is different from the first setting and which can be called up using the second treadle.
(see chapter 7.03 Pedal)

8 Installation and commissioning



This machine may only be installed and commissioned by qualified specialists!
All relevant safety regulations are to be adhered to!



If the machine is delivered without a table, the frame and table top used must be able to support the weight of the machine and the motor. The table must guarantee a sufficient level of stability - even during sewing.

8.01 Installation

Connections for electrical and compressed air supplies must be available at the machine's location.

A firm, horizontal surface and adequate lighting must also be guaranteed where the machine is installed.



The table top is lowered for packaging. The following is a description of how to adjust the table top height.

8.01.01 Adjusting the height of the table top

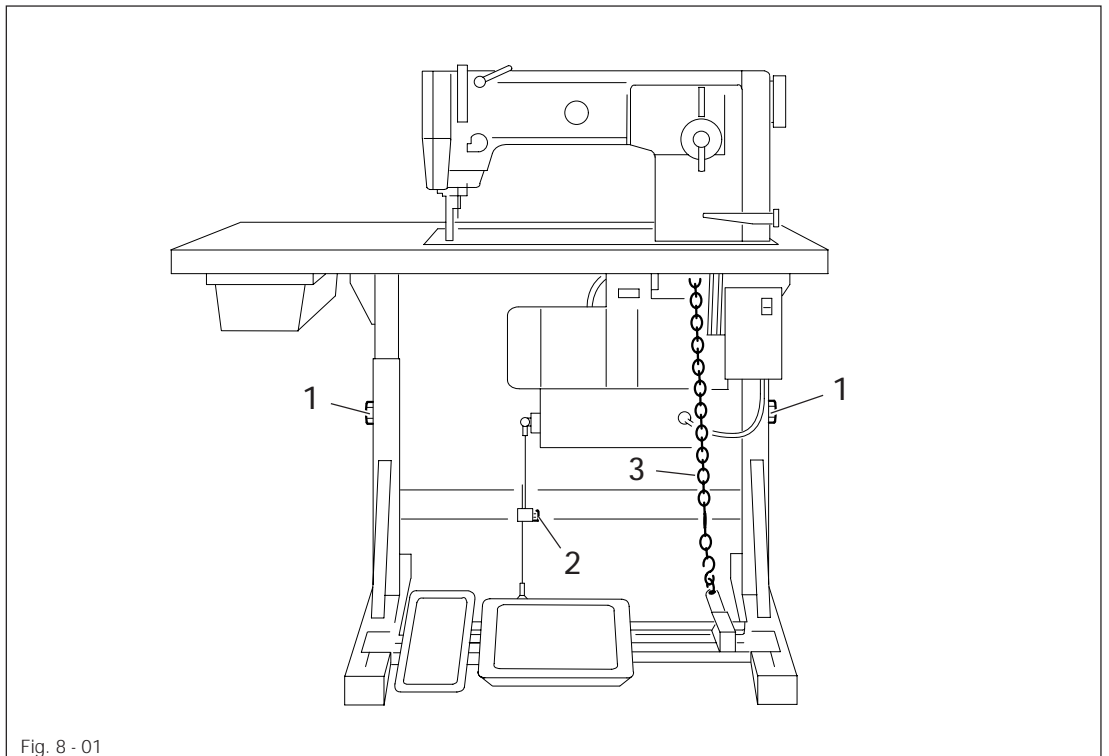

- Loosen screws 1 and 2.
- Adjust the height of the table top as desired and tighten screws 1 firmly.
- Adjust the position of the right pedal ergonomically and tighten screw 2.
- The left pedal can be adjusted by means of chain 3.

8.01.02 Tightening the V-belt

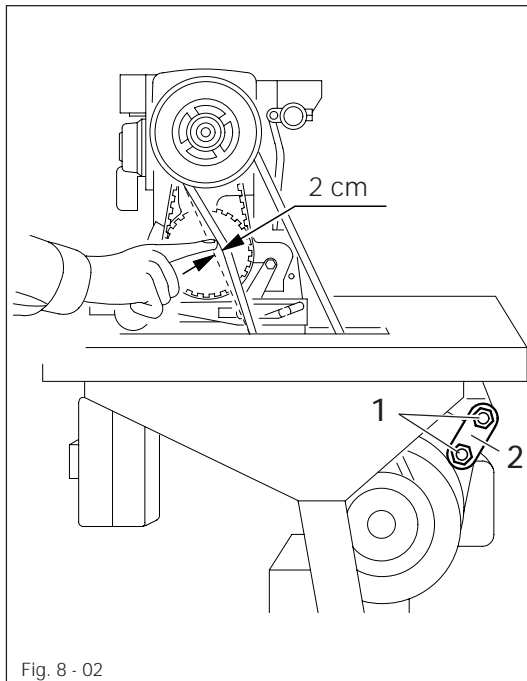

- Loosen nuts 1.
- Tighten V-belt using motor driven rocker dolly switch 2.
- Tighten nuts 1.



Fig. 8-02 shows a Quick motor. If another motor is used, proceed as described in the instruction manual of the motor manufacturer.

8.01.03 Mounting the upper V-belt guard

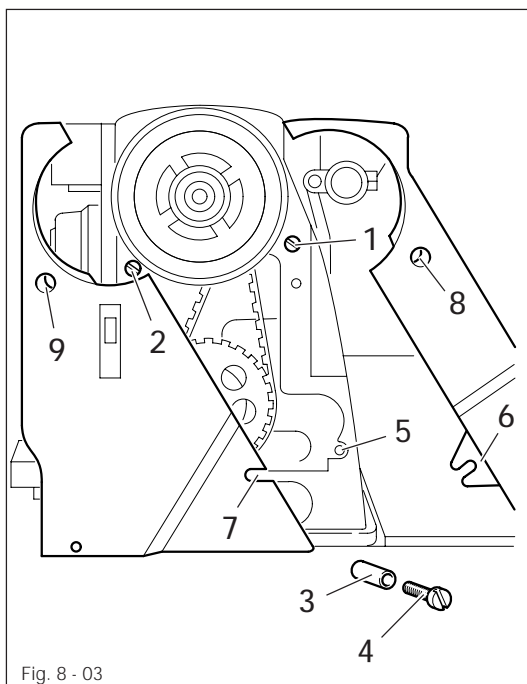

- Slide the left and right halves of the V-belt guard into place with the slots behind the heads of screws 1 and 2.
- Screw screw 4 with distance bush 3 into threaded hole 5.
- Align the V-belt guard, taking care that clip 6 is behind slot 7 and in front of distance bush 3.
- Tighten screws 1 and 2 (through holes 8 and 9) and screw 4.

8.01.04 Fitting the lower V-belt guard

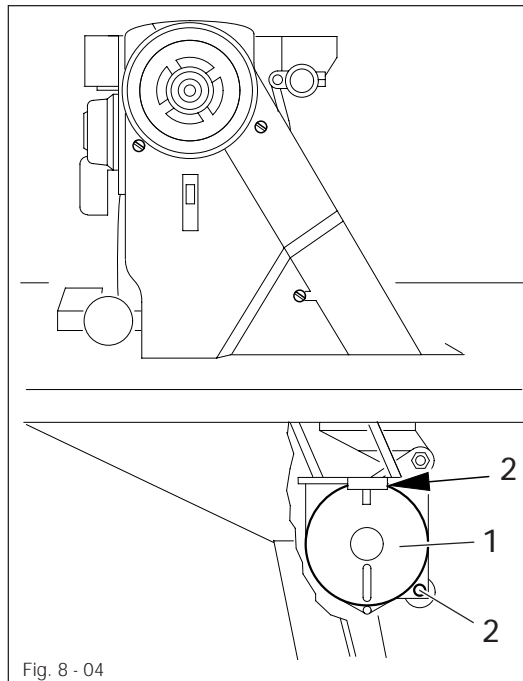

Fig. 8 - 04

- Align the V-belt guard 1 so that the motor wheel and the V-belt run freely.
- Tighten screws 2.



Fig. 8-04 shows a Quick motor. If another motor is used, proceed according to the instruction manual of the manufacturer.

8.01.05 Mounting the reel stand and the sewing lamp

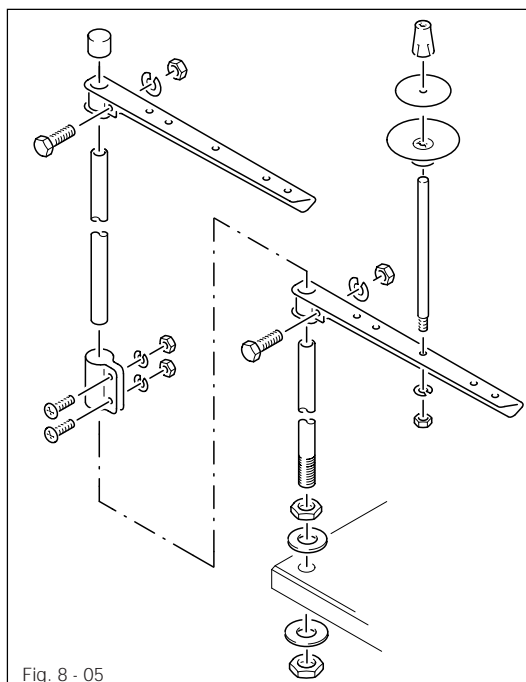

Fig. 8 - 05

- Mount the reel stand as shown in Fig. 8-05
- Have the sewing lamp screwed onto the table top by specialist personnel, using wood screws (5 x 35).



The sewing lamp is included in the standard equipment.

8.02 Commissioning

- Check the machine, especially the electrical wiring and pneumatic tubes, for possible damage.
- Clean the machine thoroughly and then oil it / fill the oil reservoirs (see **chapter 10 Care and maintenance**).
- Have specialist personnel check if the motor of the machine can be operated with the available power supply and if it is connected properly in the terminal box. If not, do not operate the machine!
- The balancewheel must rotate toward the operator when the motor is running, if not, have the motor adjusted by specialist personnel.
- Connect the machine to the compressed air supply. The gauge must indicate an air pressure of 6 bar. If necessary, set to this value (see **chapter 10.04 Checking the air pressure**).

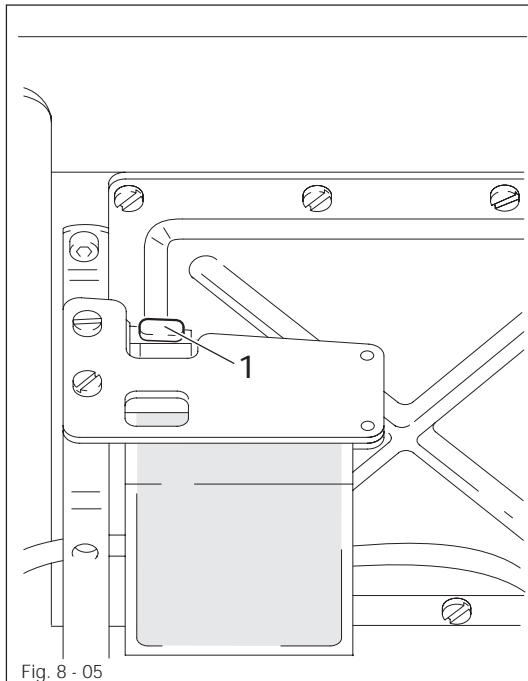

- Before operating the machine for the first time, remove stopper 1 from its hole.



Stopper 1 serves only to protect the machine while being transported and must not be used while sewing.

8.03 Switching the machine on/off

- Turn the machine on/off (see chapter 7.01 On/Off switch).
- Carry out a test run.

9

Preparation



All regulations and instructions in this Instruction Manual are to be adhered to. Special attention is to be paid to all safety regulations!



All preparatory work must only be carried out by appropriately trained personnel. When carrying out preparatory work, the machine is to be separated from the power supply by turning off the On/Off switch or by removing the plug from the socket.

9.01

Inserting the needle

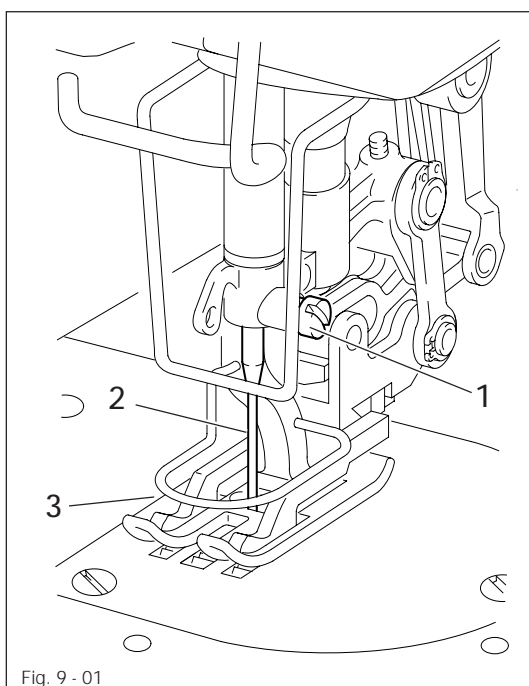

Turn the machine off!

Only use the following needle systems:

Top feed version -706/81: 438

Top feed version -706/83: 438-35

- Bring the needle bar into its highest position.
- Loosen screw 1.
- Insert needle 2 as far as possible.
- The long needle-groove must be facing the front.
- Tighten screw 1.



The choice of needle depends on the model of the machine and the thread and material to be used (see chapter 3.03 Needle and thread).

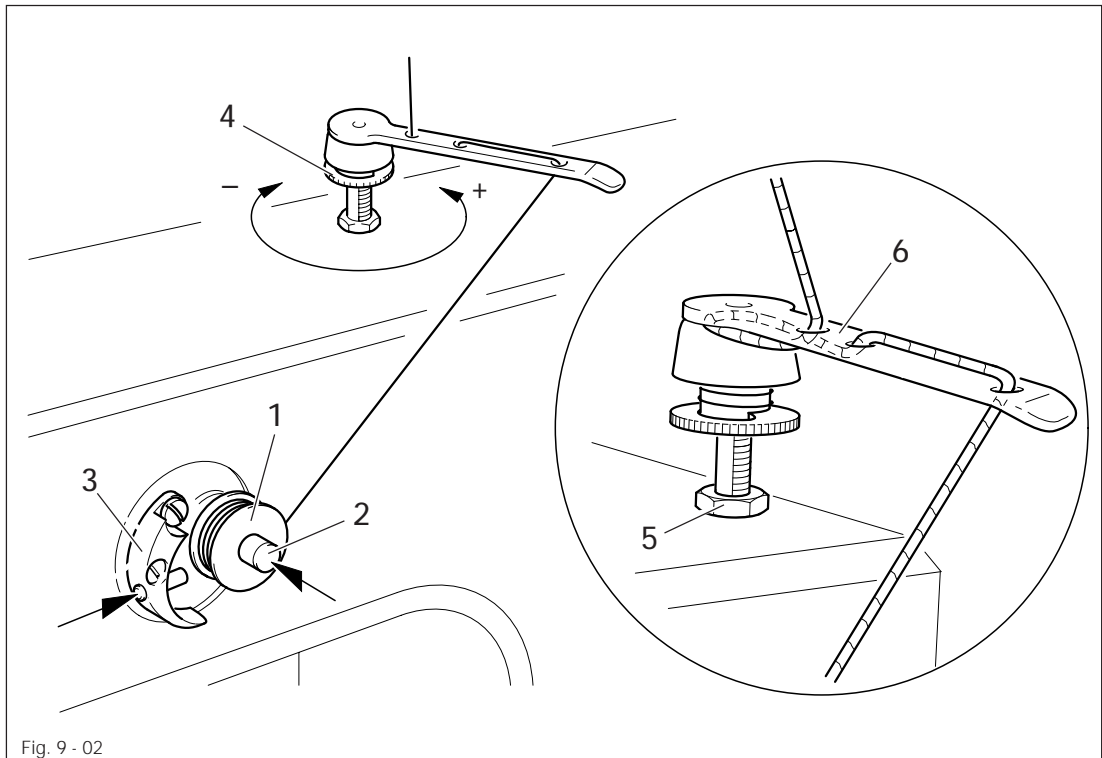

Fig. 9 - 02

- Place the empty bobbin 1 onto the bobbin winder spindle 2.
- Thread the thread in accordance with Fig. 9-02 and wind it a few times around bobbin 1 in a clockwise direction.
- Switch the bobbin winder on by pushing the bobbin winder spindle 2 and lever 3 simultaneously.



The bobbin is wound during sewing.

- The tension of the thread on bobbin 1 can be adjusted using milled screw 4.
- The bobbin winder stops automatically when bobbin 1 is full.

If the thread is wound irregularly:

- Loosen nut 5.
- Turn thread guide 6 accordingly.
- Tighten nut 5.

9.03 Removing/inserting the bobbin case

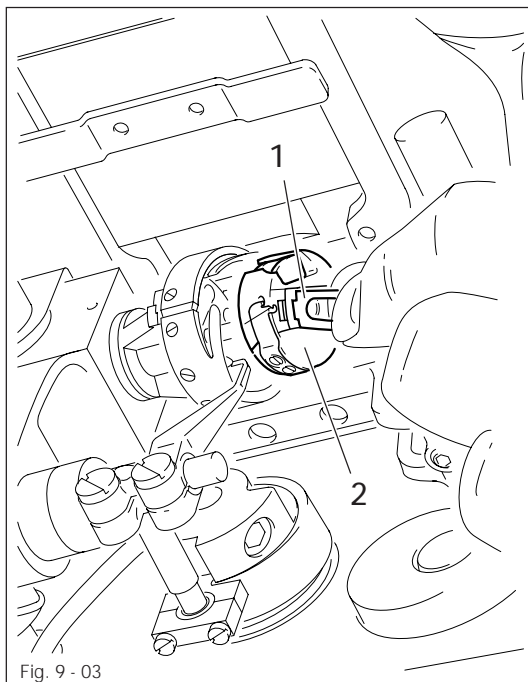

Turn the machine off!

Removing the bobbin case.

- Lift clip 1 and remove bobbin case 2.

Inserting the bobbin case:

- Insert bobbin case 1 until you feel it click into place.

9.04 Threading the bobbin case, adjusting the thread tension

9.04.01 PFAFF 937 without thread trimmer -900/..

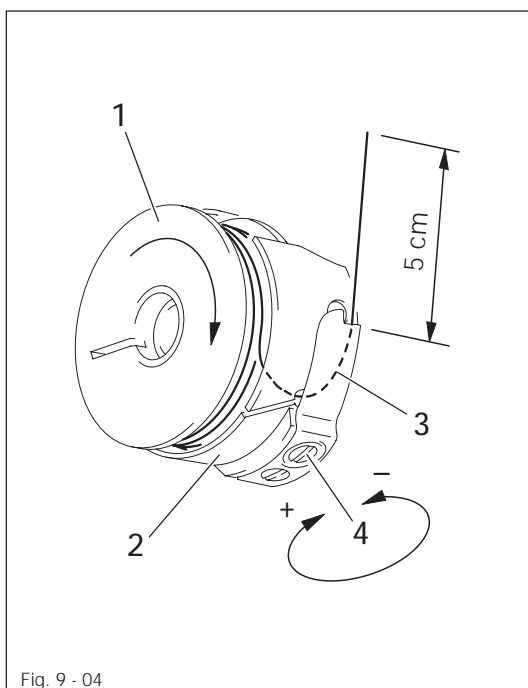

- Insert bobbin 1 into bobbin case 2.
- Guide the thread through the slot under spring 3.
- Adjust the thread tension by turning screw 4.



When the thread is pulled the bobbin 1 must rotate in the direction of the arrow.

9.04.02 PFAFF 937 with thread trimmer -900/..

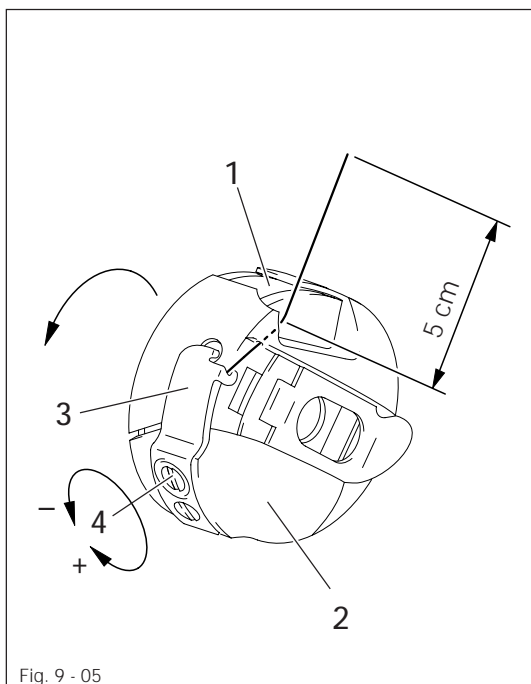

- Insert bobbin 1 into bobbin case 2.
- Guide the thread through the slot under spring 3.
- Adjust the thread tension by turning screw 4.



When the thread is pulled the bobbin 1 must rotate in the direction of the arrow.

9.05 Threading the needle thread

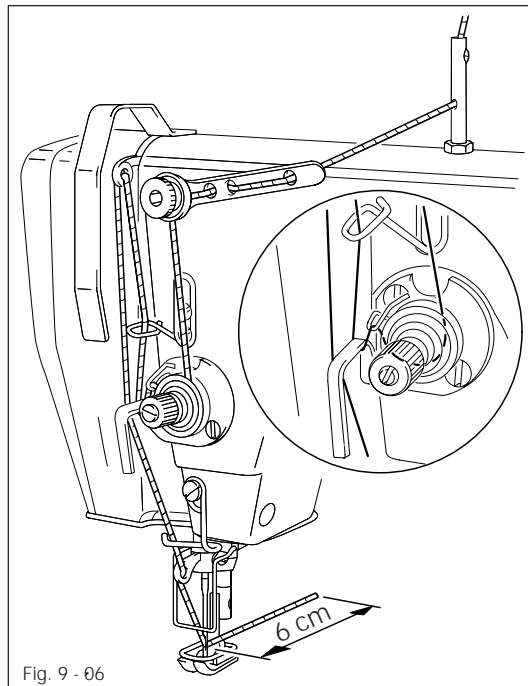

Turn the machine off!

- Thread the needle thread in accordance with Fig. 9-06.

9.06 Adjusting the needle-thread tension

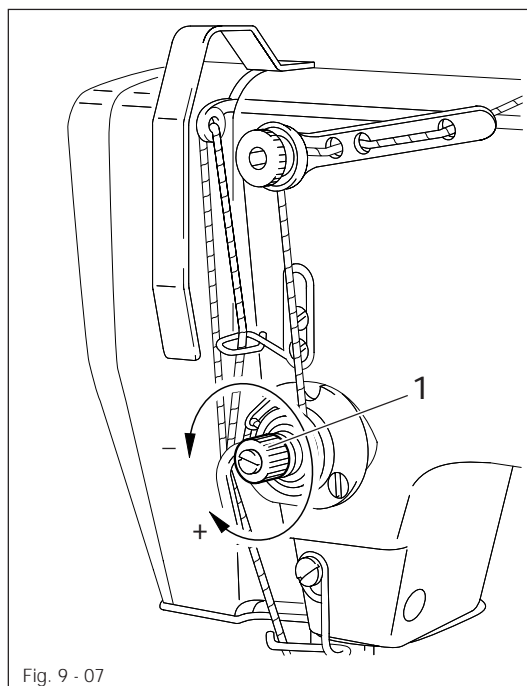

- Adjust the needle-thread tension by turning milled screw 1.

9.07

Adjusting the zigzag stitch and the needle position

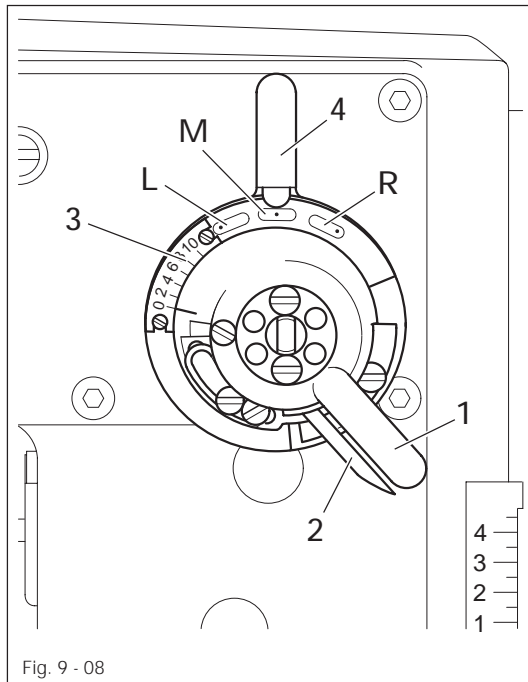

- Adjust the zigzag stitch width by turning the zigzag-stitch adjustment lever 1.
- To adjust locking lever 2, press against the zigzag-stitch adjustment lever 1.
- The setting can be seen on scale 3.
- Adjust the needle position by turning the needle-position adjustment lever 4.

L = Needle position left
M = Needle position middle
R = Needle position right

9.08

Adjusting the stitch length

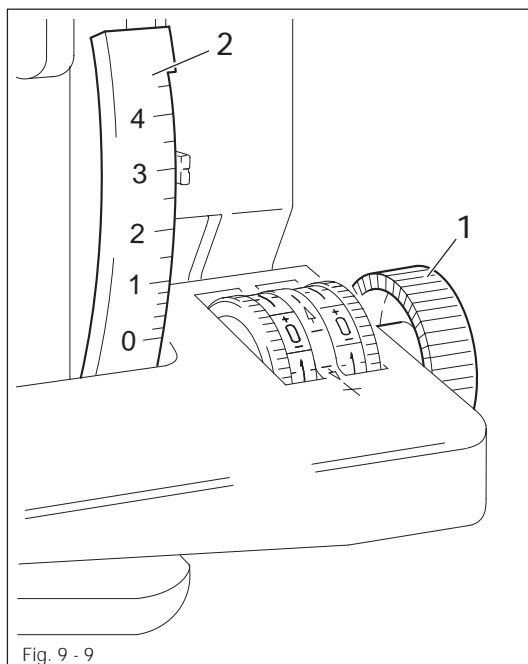

- Adjust the stitch length by turning the stitch-length adjustment wheel 1.
- The setting can be seen on scale 2.

9.09 Adjusting the top feed

9.09.01 Normal sewing

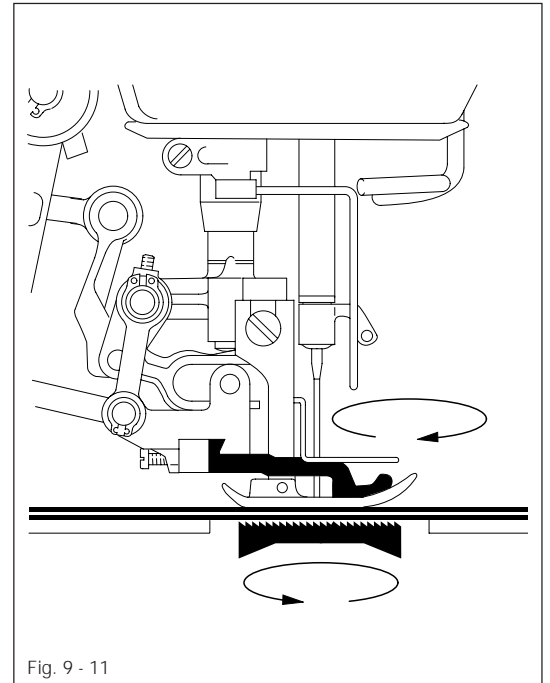
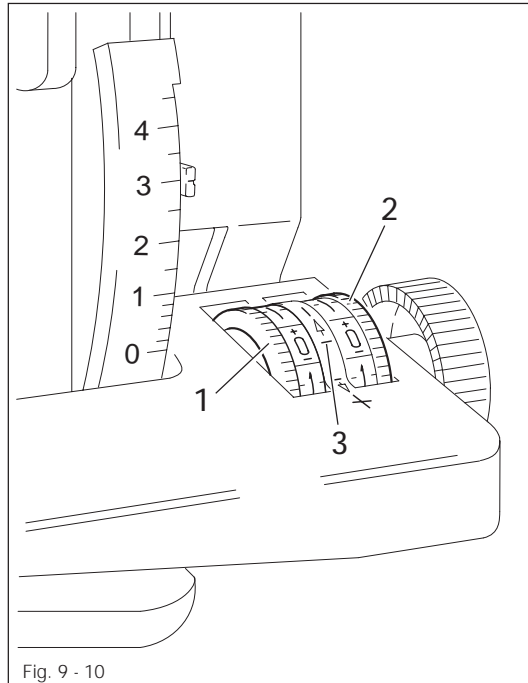

- Turn adjustment wheel 1 to "+" as far as it will go.
- Turn adjustment wheel 2 until "0" is at marking 3.
- Turn adjustment wheel 1 back until "0" is at marking 3.
- Adjust the stitch length (see chapter 9.08 Adjusting the stitch length).



In normal sewing mode the bottom and top feeding motions are the same length.

9.09.02 Applying fullness constantly

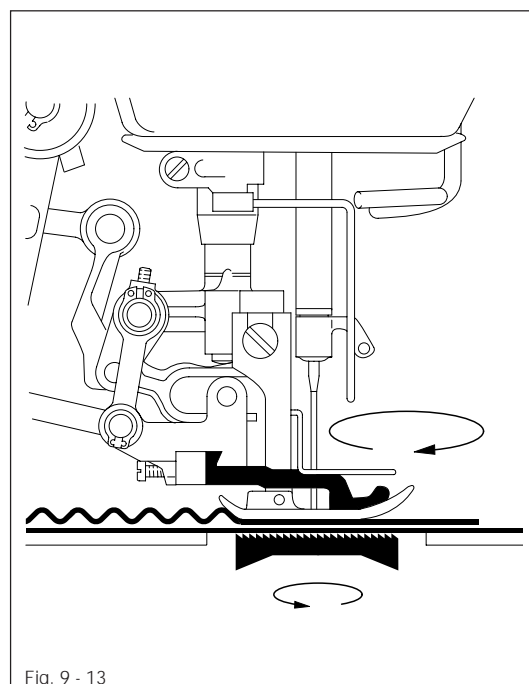
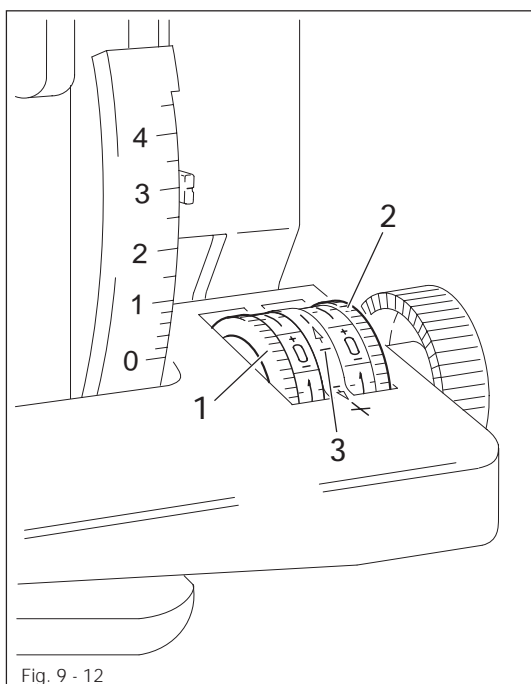

- Turn adjustment wheel 1 to " + " as far as it will go.
- Turn adjustment wheel 2 until the desired level of fullness (green numbers) is at marking 3.
- Turn adjustment wheel 1 back until the same green number is at marking 3.
- Adjust the stitch length (see [chapter 9.08 Adjusting the stitch length](#)).



The sum of the selected fullness level and the stitch length must not exceed 4.5 because more than this lessens the stitch length.

9.09.03 Applying fullness intermittently

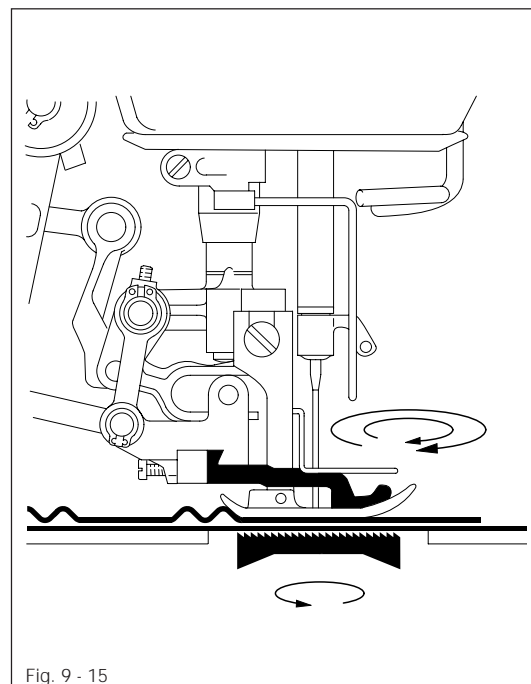
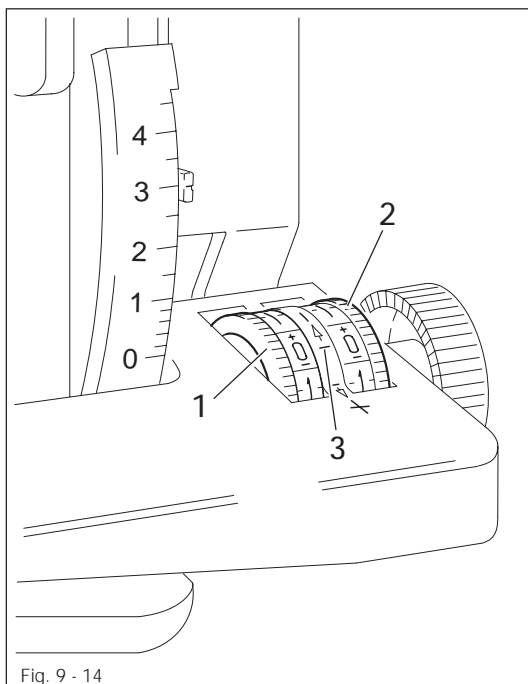

- Turn adjustment wheel 1 to "+" as far as it will go.
- Turn adjustment wheel 2 until "0" is at marking 3.
- Turn adjustment wheel 1 back until the desired level of fullness (green numbers) is at marking 3.
- Adjust the stitch length (see chapter 9.08 Adjusting the stitch length).



The sum of the selected fullness level and the stitch length must not exceed 4.5 because more than this lessens the stitch length.



When the left pedal is in resting position the machine sews with equal bottom and top feed strokes. By activating the left pedal the level of fullness set on adjustment wheel 1 is sewn into the top fabric layer (see chapter 7.03 Pedal).

9.09.04 Constant braking of the top fabric ply (stretching)

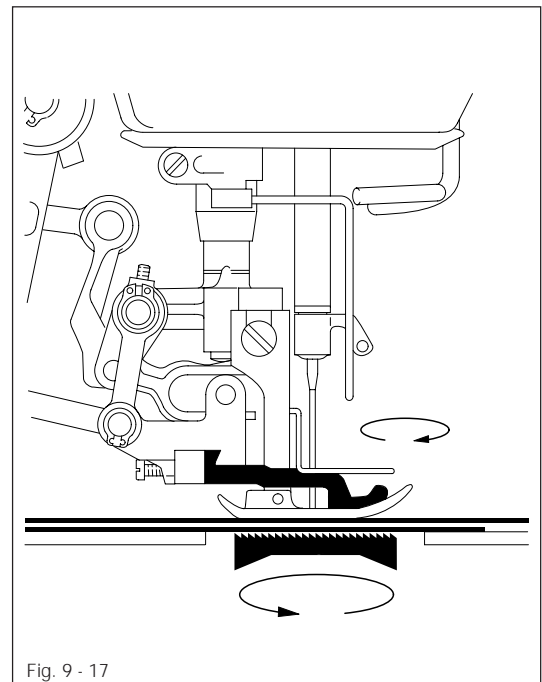
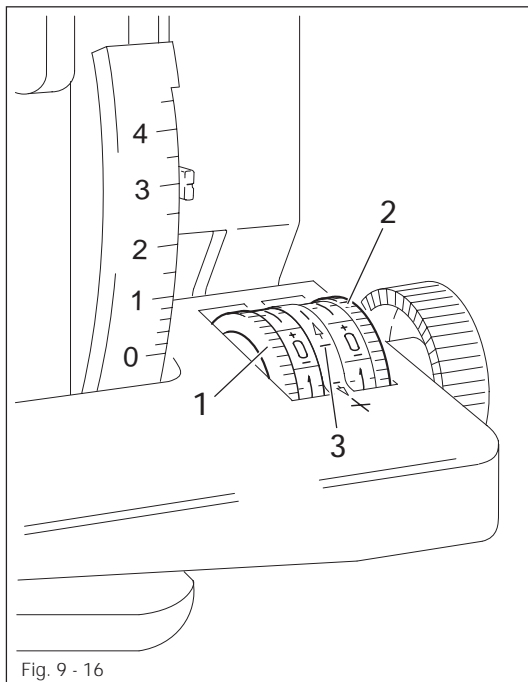

- Turn adjustment wheel 1 to " + " as far as it will go.
- Turn adjustment wheel 2 until the desired level of stretch (red numbers) is at marking 3.
- Turn adjustment wheel 1 back until the same red number is at marking 3.
- Adjust the stitch length (see [chapter 9.08 Adjusting the stitch length](#)).

9.09.05 Braking the top fabric ply or intermittently applying fullness

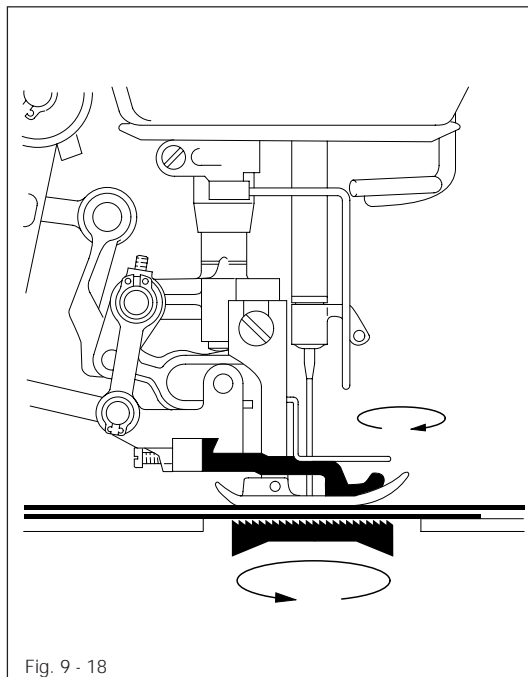

Fig. 9 - 18

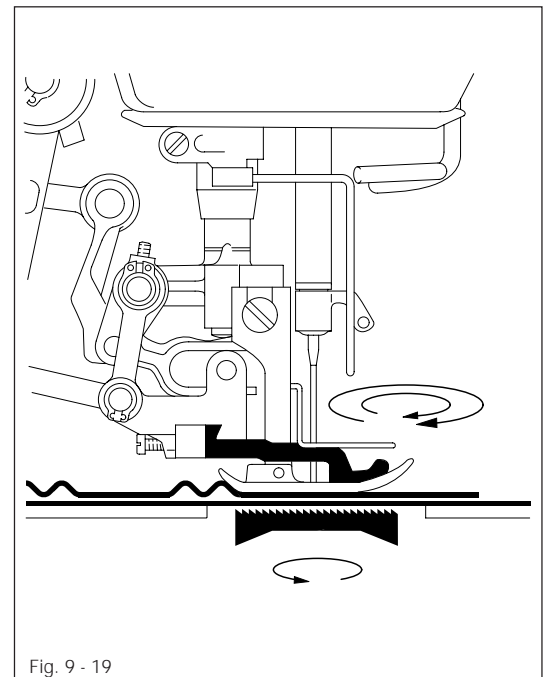

Fig. 9 - 19

- Turn adjustment wheel 1 to “+” as far as it
- Turn adjustment wheel 2 until the desired level of stretch (red numbers) is at marking 3.
- Turn adjustment wheel 1 back until the desired level of fullness (green number) is at marking 3.
- Adjust the stitch length (see chapter 9.08 Adjusting the stitch length).



The sum of the selected fullness level and the stitch length must not exceed 4.5 because more than this lessens the stitch length.



When the left pedal is in resting position the machine stretches the top fabric layer constantly. By activating the left pedal the level of fullness set on adjustment wheel 1 is sewn into the top fabric ply (see chapter 7.03 Pedal).

10 Care and maintenance

Cleaning	daily, more often when in continuous operation
Oil level (zigzag eccentric lubrication)	daily before use
Oil level (hook oil-reservoir)	yearly*
Check the air pressure	daily before use
Water container of the air filter/regulator	daily before use



* This maintenance interval is valid for an average running time of a single-shift sewing room. If the machine running-times are higher, shorter maintenance intervals are advisable.

10.01 Cleaning



Turn the machine off!



- Lay the machine head on its back.
- Clean the hook and the hook compartment daily, more often when in continuous operation.
- Return the machine head to its upright position with both hands.



Danger of crushing between machine head and table top!

10.02 Lubricating the hook

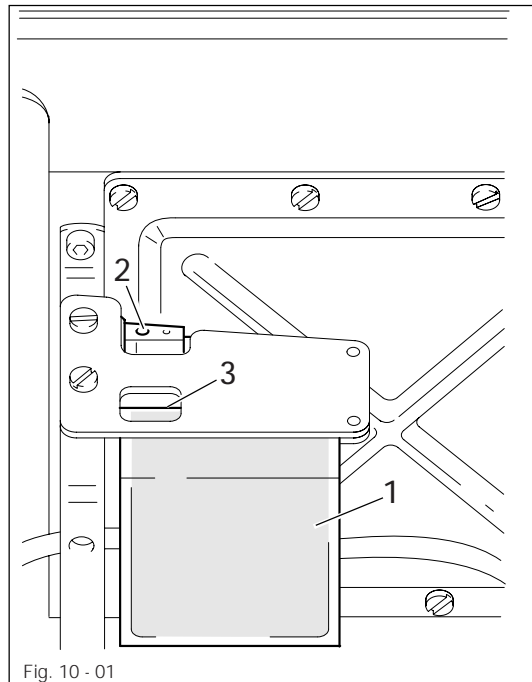

Fig. 10 - 01

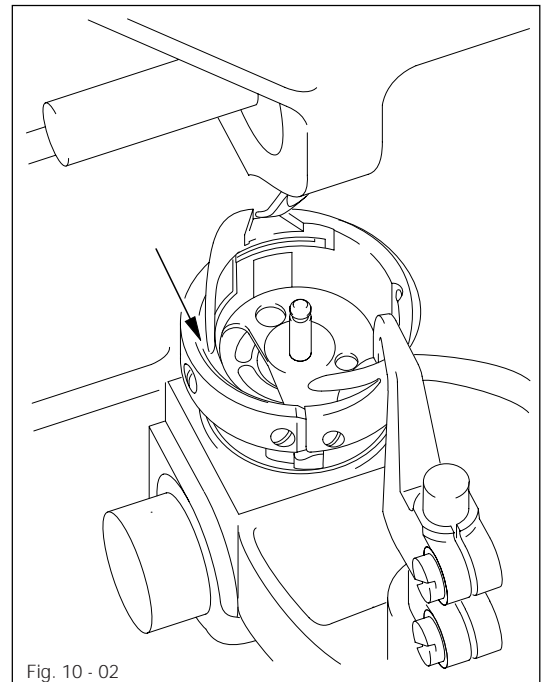

Fig. 10 - 02



Turn the machine off!



Only use oil with a mean viscosity of 10.0 mm²/s at 40°C and a density of 0.847 g/cm³ at 15°C.

- Lay the machine head on its back.
- Fill the oil reservoir 1 up to the upper marking 3 through hole 2.
- Before operating the machine for the first time or after longer stationary periods, add a few additional drops of oil into the hook race (see arrow in Fig. 10-02).



Return the machine to its upright position with both hands. Danger of crushing between machine head and table top!

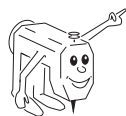

We recommend PFAFF sewing machine oil.
Part no. 280-1-120 105.

10.03 Lubricating the zigzag drive

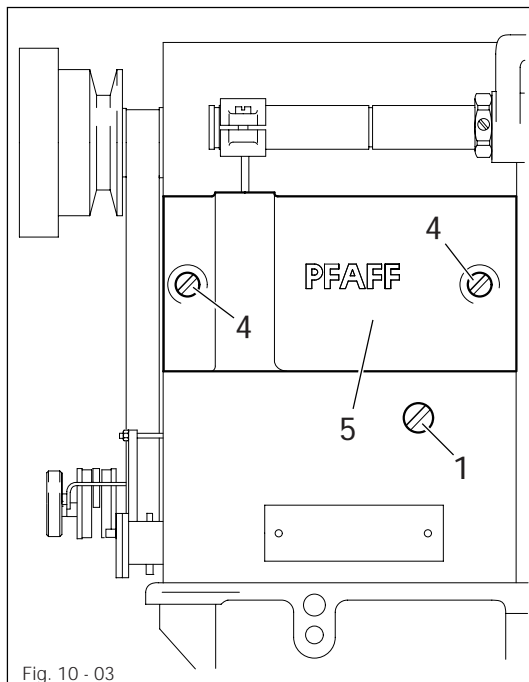

Fig. 10 - 03

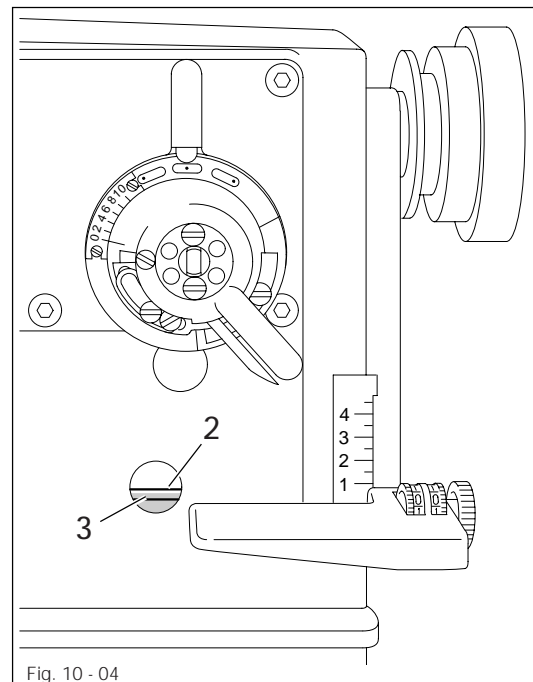

Fig. 10 - 04



Always check the oil level before every use of the machine.

- If required, unscrew screw 1 and fill the reservoir with oil up to the upper marking 2.
- Retighten screw 1.



It is beneficial to remove cover 5 when pouring larger quantities of oil into the reservoir: e.g. when filling for the first time before operating the machine for the first time.

- Unscrew screw 4 and remove cover 5.
- Take care to ensure that no dirt gets into the housing.
- Fill the reservoir with oil up to the upper marking 2.
- Clean the supporting surface of cover 5, housing and seal.
- Replace cover 5 and tighten screws 4.



Never allow the oil level to drop below the minimum mark 3.



Only use oil with a mean viscosity of 22.0 mm²/s at 40°C and a density of 0.865 g/cm³ at 15°C.

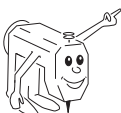

We recommend PFAFF sewing machine oil.
Part no. 280-1-120 144.

10.04 Checking the air pressure

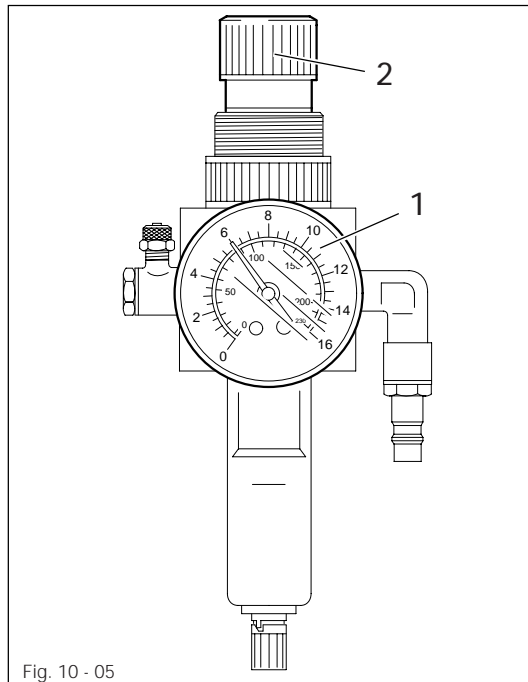

- Check the air pressure on the gauge 1 before every use of the machine.
- The gauge 1 must show a pressure of approx. 6 bar.
- Adjust to this value if necessary.
- To do so lift button 2 and turn it until the gauge shows approx. 6 bar.

10.05 Emptying/cleaning the water container of the air filter/regulator

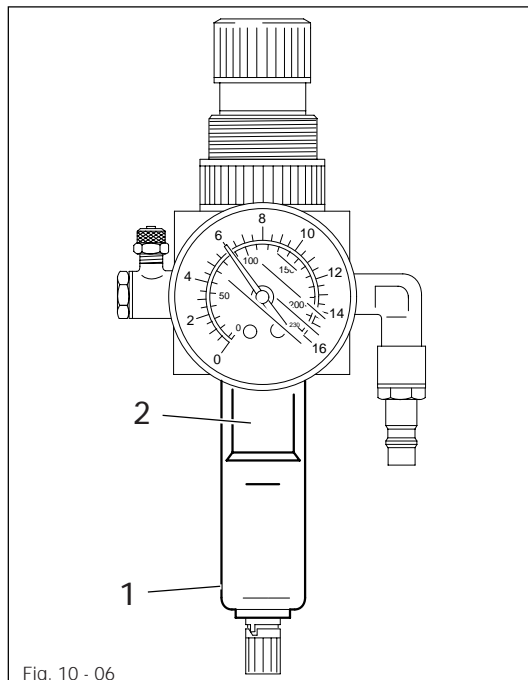

Turn the machine off!
Disconnect the compressed air hose from the air filter/regulator.

Emptying water container 1

- Water container 1 empties itself automatically when the compressed air hose is removed from the air filter/regulator.
- Unscrew water container 1.
- Screw out filter 2.
- Clean filter 2 with compressed air or isopropyl alcohol (Part No. 95-665 735-91)
- Screw filter 2 back in and screw on water trap 1.

11 Adjustment



On the PFAFF 937 no c-clamps may be attached to the needle bar as this would damage the special coating on the needle bar.

11.01 Notes on adjusting

All adjustments in these adjustment instructions are based on a completely assembled machine and must only be carried out by trained specialists. Covers on the machine which have to be removed and replaced for checks and adjustment work are not mentioned.

11.02 Tools, gauges and other accessories

- Screwdrivers with blade width from 2 to 10 mm
- Wrenches (spanners) with jaw width from 7 to 14 mm
- Allan keys from 1.5 to 6 mm
- Metal rule, Part No. 08-880 218-00
- Blocking pin (5 mm diameter), Part No. 13-030 341-05
- Vibrating presser adjustment gauge, Part No. 91-129 995-05
- Hook bearing bracket gauge, Part No. 91-129 996-05
- Sewing thread and test material

11.03 Abbreviations

tdc = top dead center

bdc = bottom dead center

11.04 Check and adjustment aid



By blocking with holes 1 - 5 the required needle bar positions can be fixed exactly.

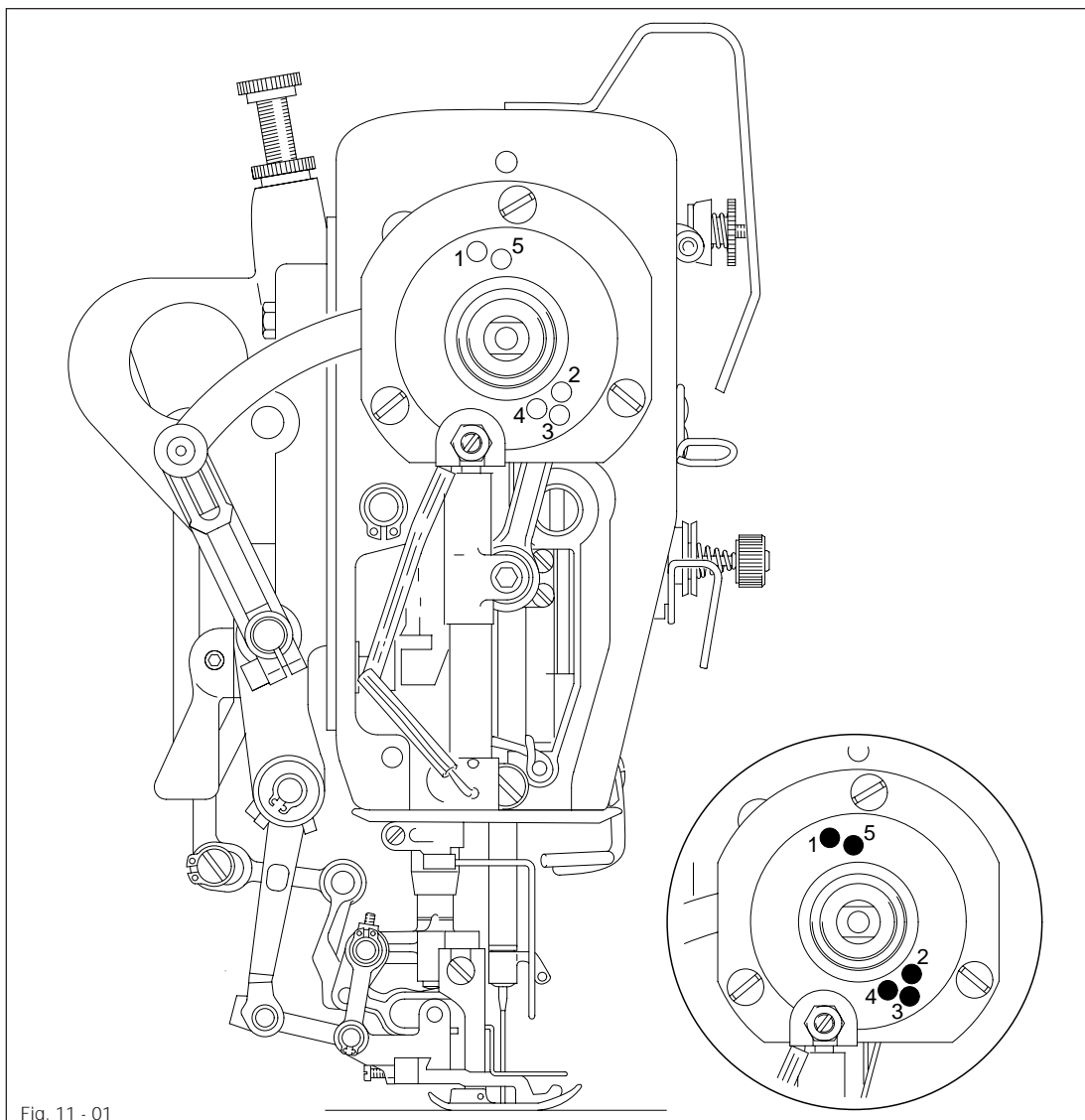
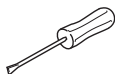

Fig. 11 - 01



- Turn the balance wheel until the needle bar has approximately reached the required position.
- Place the 5 mm blocking pin in the appropriate hole and put pressure on it.
- Turn the balance wheel forwards and backwards a little until the blocking pin moves into the slot in the crank behind the bearing plate, thus blocking the machine.

Hole 1	=	2.0 mm after the bottom dead center of the needle bar (2.0 past tdc)
Hole 2	=	Top dead center of the needle bar (tdc)
Hole 3	=	0.25 mm after the top dead center of the needle bar (0.25 past bdc)
Hole 4	=	1.0 mm after the top dead center of the needle bar (1.0 mm past tdc)
Hole 5	=	4 mm after the bottom dead center of the needle bar (4.0 past bdc)

Adjustment

11.05 Adjusting the basic machine

11.05.01 Balancing weight

Requirement

With the needle bar at bdc the largest eccentricity of the balancing weight 1 must be pointing upwards.

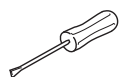
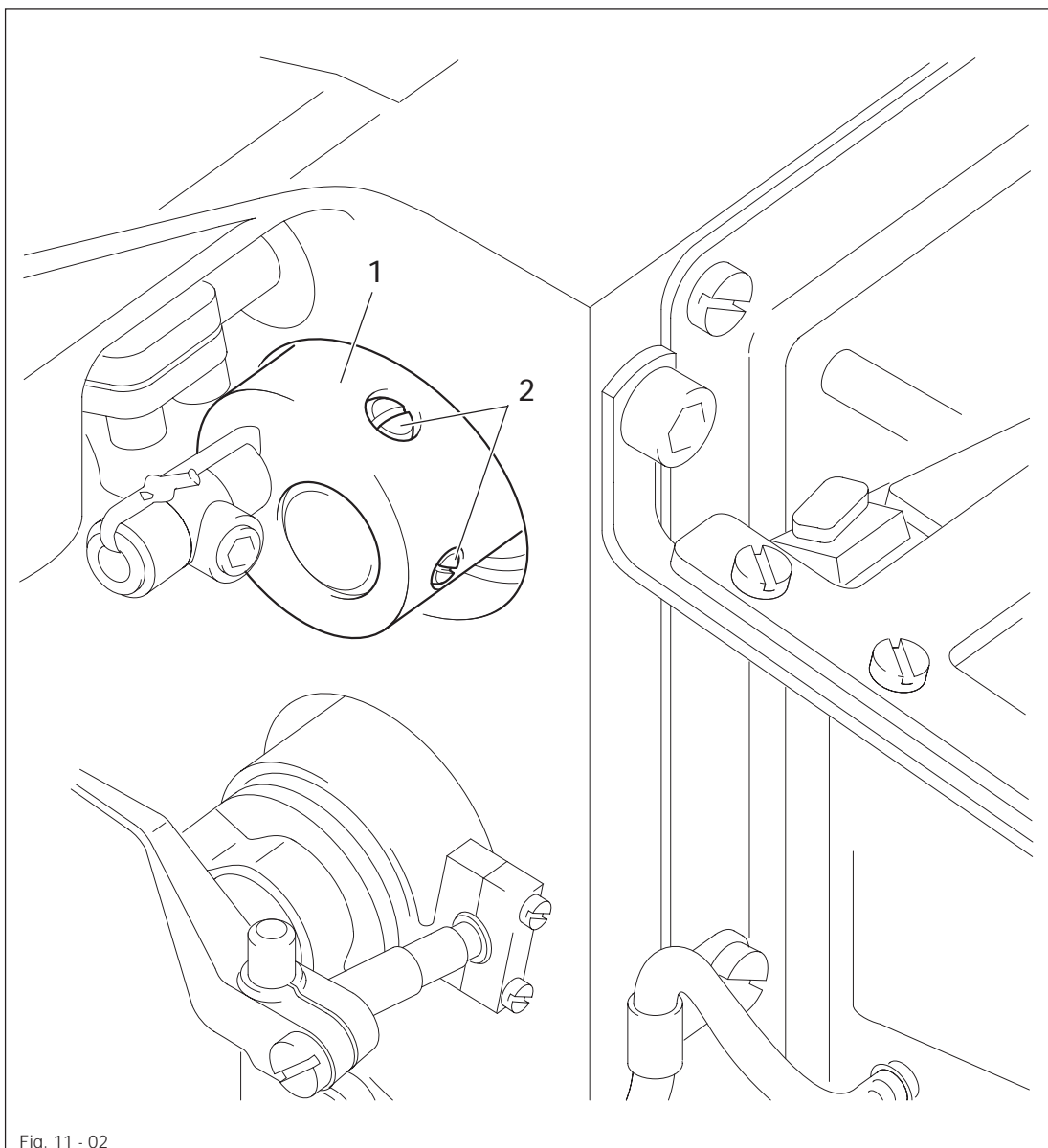

- Bring the needle bar to bdc.
- Loosen nut 2 and screw 3.
- Turn eccentric pin 1 in accordance with the **requirement**.
- Tighten nut 2 and screw 3.

11.05.02 Centering the needle in the needle hole (in sewing direction)

Requirement

With the zigzag setting at "0" and the needle position set at "middle" the needle must enter the center of the needle hole as viewed in the direction of sewing.

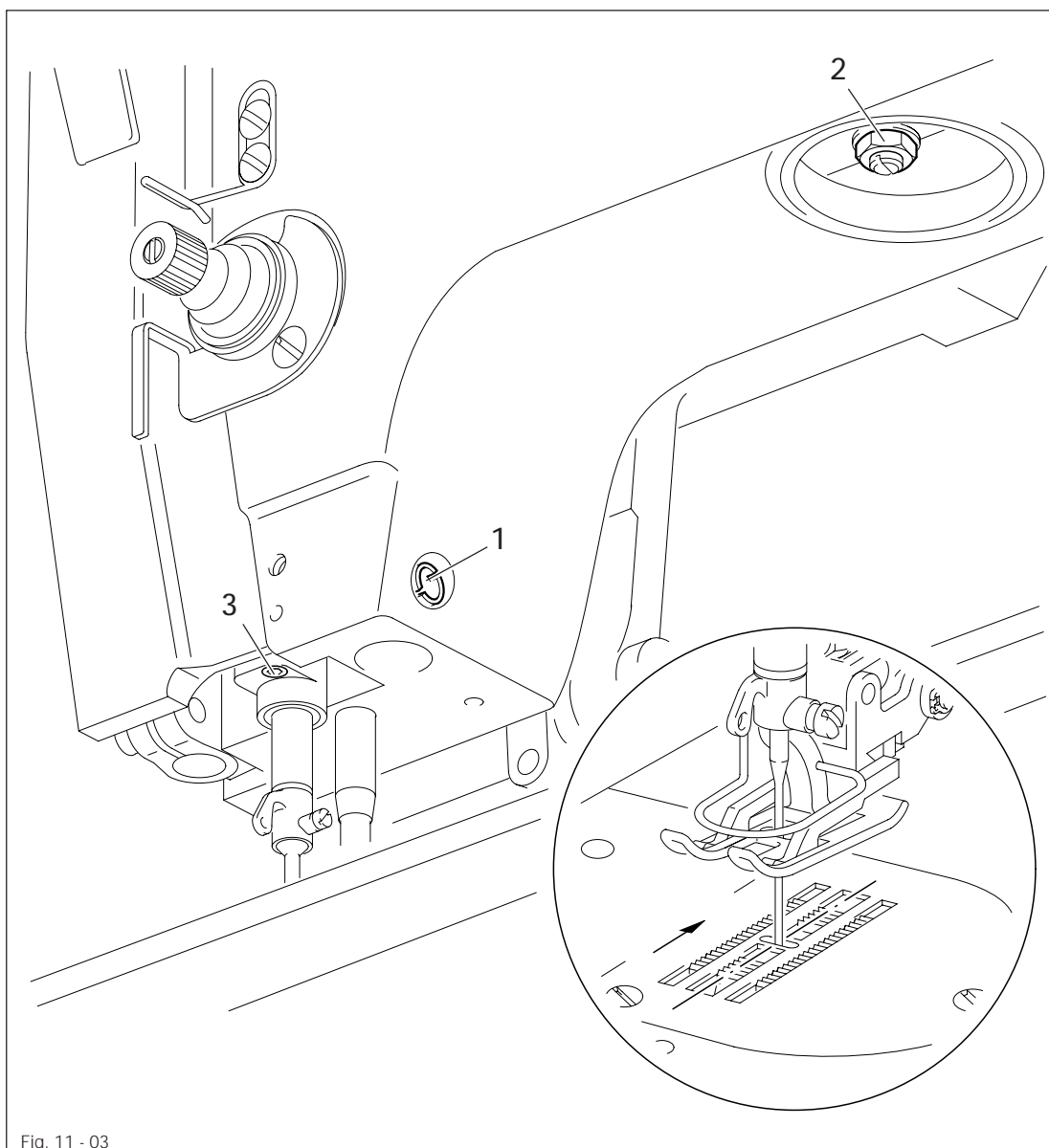
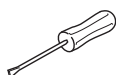

Fig. 11 - 03



- Bring the needle bar to bdc.
- Loosen nut 2 and screw 3.
- Turn eccentric pin 1 in accordance with the requirement.
- Tighten nut 2 and screw 3.

11.05.03 Parallel guiding of the needle bar

Requirement

Guide bar 5 must be parallel to the needle bar.

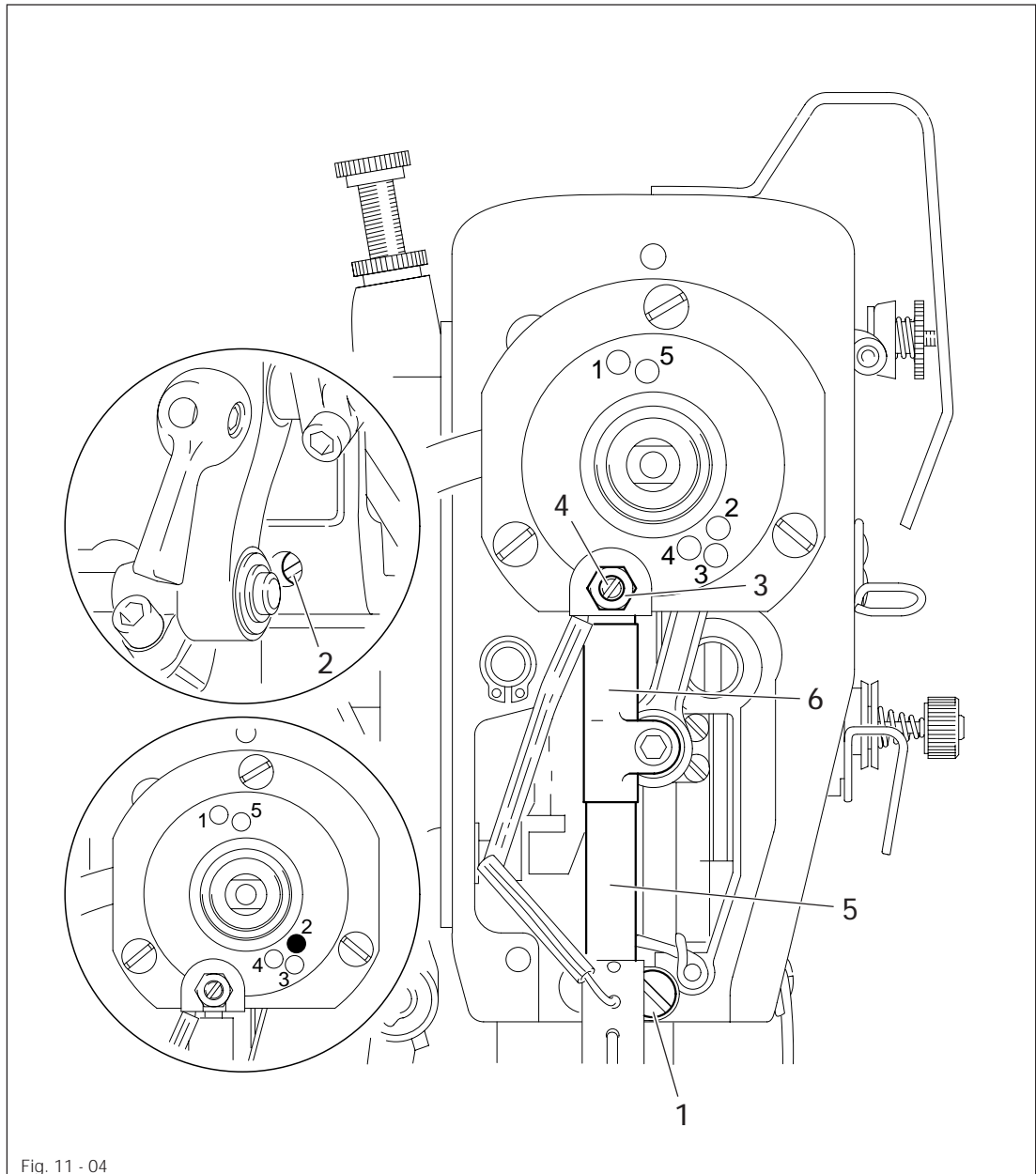
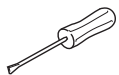

Fig. 11 - 04



- Bring the needle bar to tdc (hole 2).
- Loosen screws 1,2 and nut 3.
- The largest eccentricity of pin 4 must be facing downwards.
- Bring the groove on guide bar 5 into a position in which it rests against eccentric pin 4, turn eccentric pin 4 in accordance with the **requirement** and tighten nut 3.
- Push guide bar 5 downwards and then upwards as far as possible. Bushing 6 must not move laterally during this movement (readjust eccentric pin 4 if necessary).
- Move guide bar 5 until it rests against eccentric pin 4 and tighten screws 1 and 2.

11.05.04 Locking lever

Requirement

The zigzag stitch adjustment lever 3 must be able to be locked in any position.

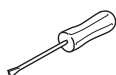
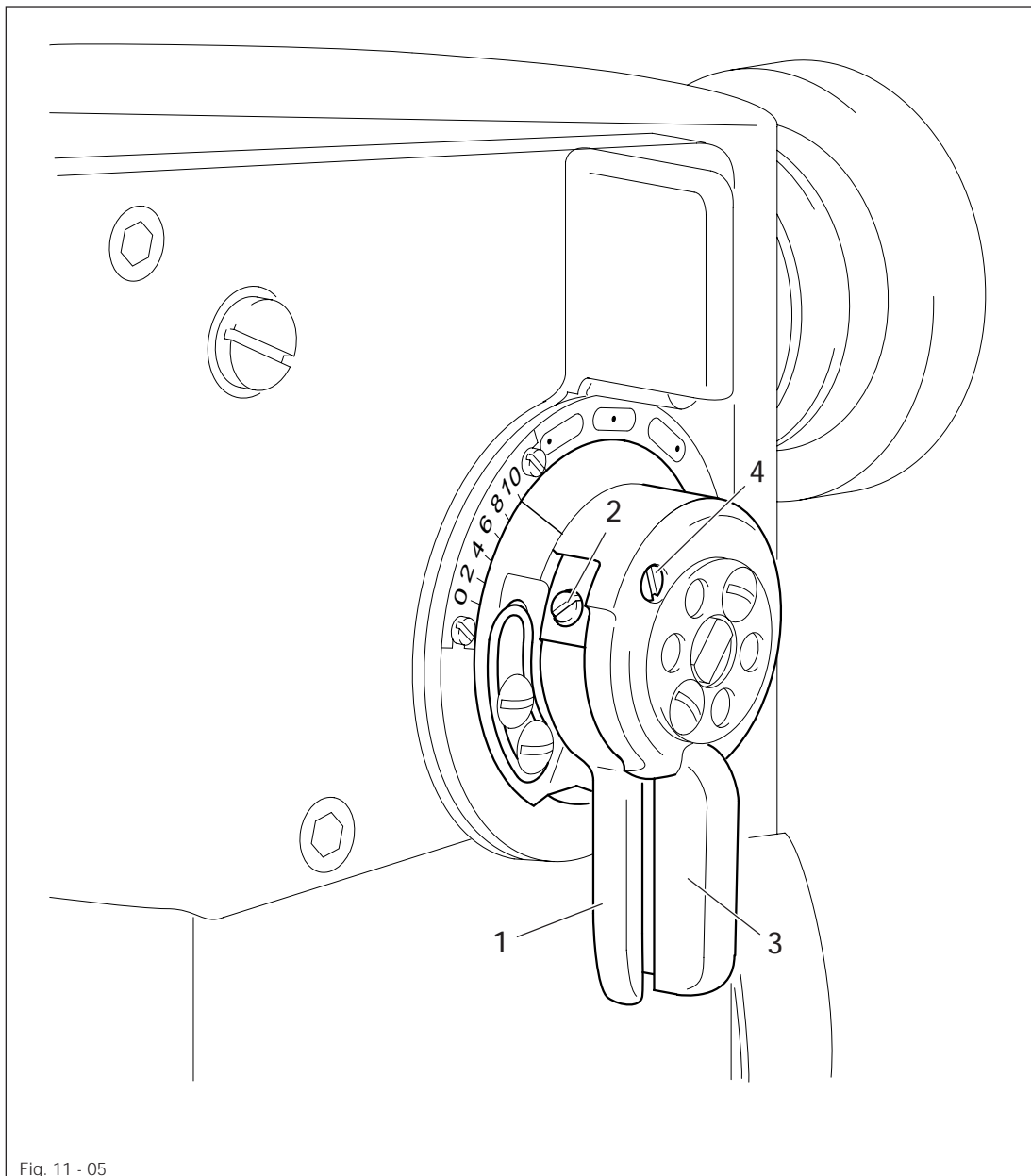

- Loosen screw 2.
- Press locking lever 1 against the zigzag stitch adjustment lever 3.
- Turn pivot pin 4 as far as possible to the left.
- Release locking lever 1.
- Locking lever 1 must be parallel to the zigzag stitch adjustment lever 3.
- Tighten screw 2.

11.05.05 Zero stitch and zigzag stitch scale

Requirement

With the zigzag stitch set at "0":

1. the needle bar must not move laterally when the balancewheel is turned and
2. the marking "0" on scale 1 must be at marking 2.

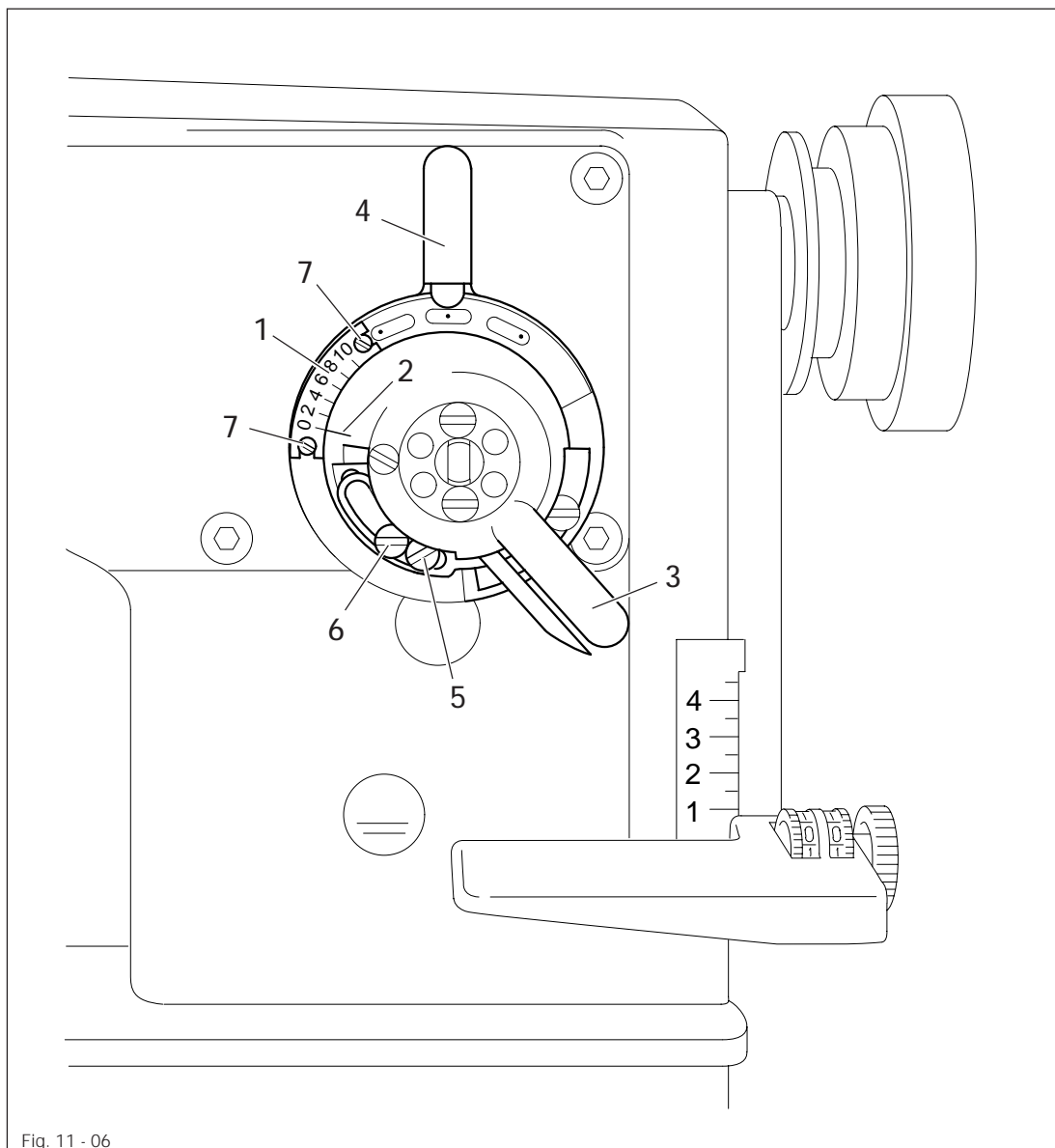
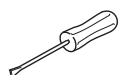

Fig. 11 - 06



- Set the needle position adjustment lever 4 to "middle" and loosen screws 5 and 6.
- Run the machine slowly and turn the zigzag stitch adjustment lever 3 to the right until the needle bar no longer moves laterally.
- Turn the machine off. Move screw 5 to the right until it touches and then tighten it.
- Loosen screws 7 and move scale 1 in accordance with requirement 2.
- Tighten screws 7.



Screw 6 remains loose for the following adjustment.

11.05.06 Centering the needle in the needle hole (crosswise to sewing direction)

Requirement

With the zigzag stitch set at "0" and the needle position setting at "middle" the needle must enter the center of the needle hole as seen across the direction of sewing.

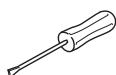
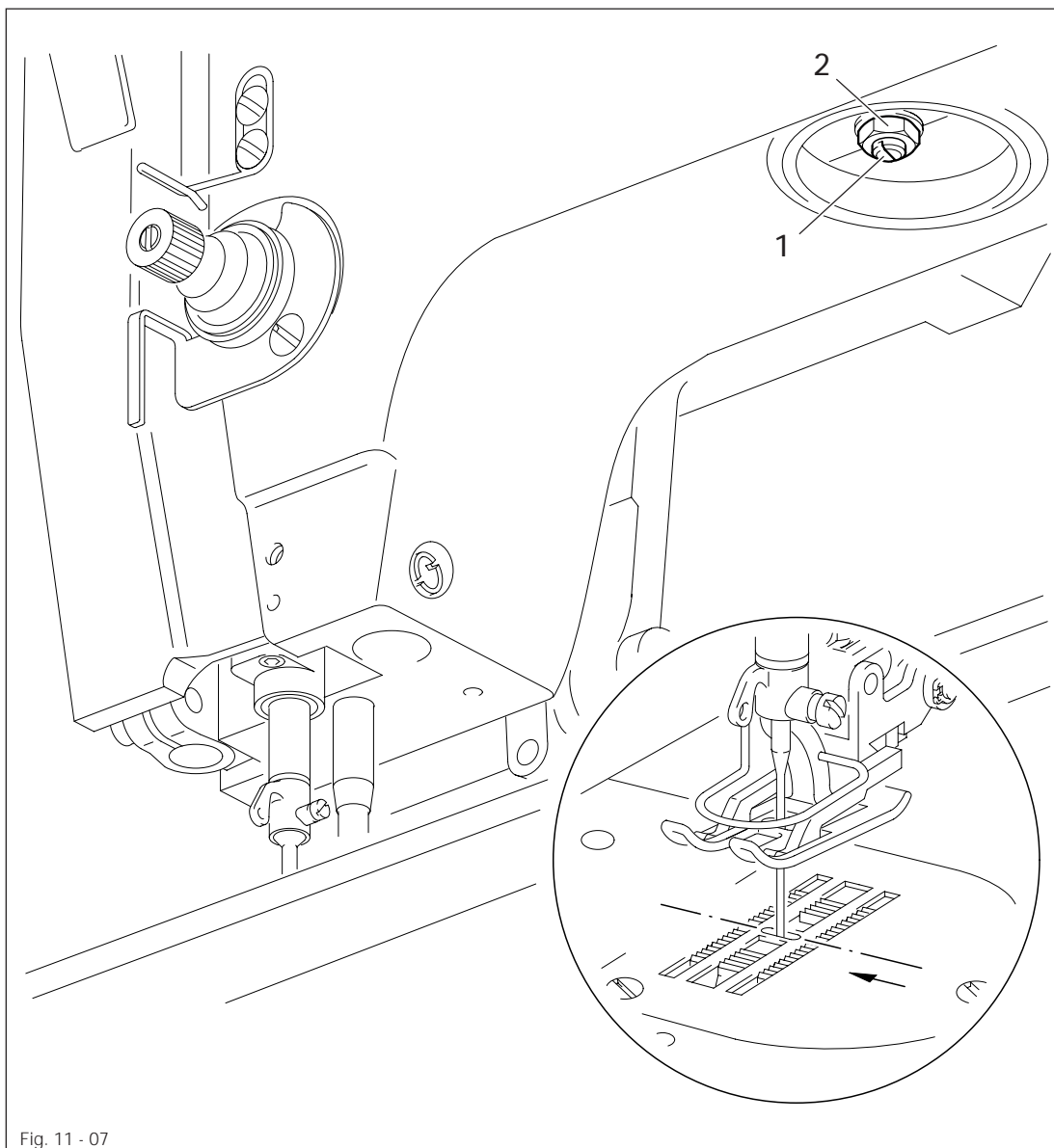

- Loosen nut 2.
- Turn eccentric pin 1 in accordance with the requirement.
- Tighten nut 1.

Adjustment

11.05.07 Zigzag stitch width

Requirement

At the largest zigzag stitch setting, marking 1 must be at the largest zigzag value on scale 2.

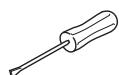
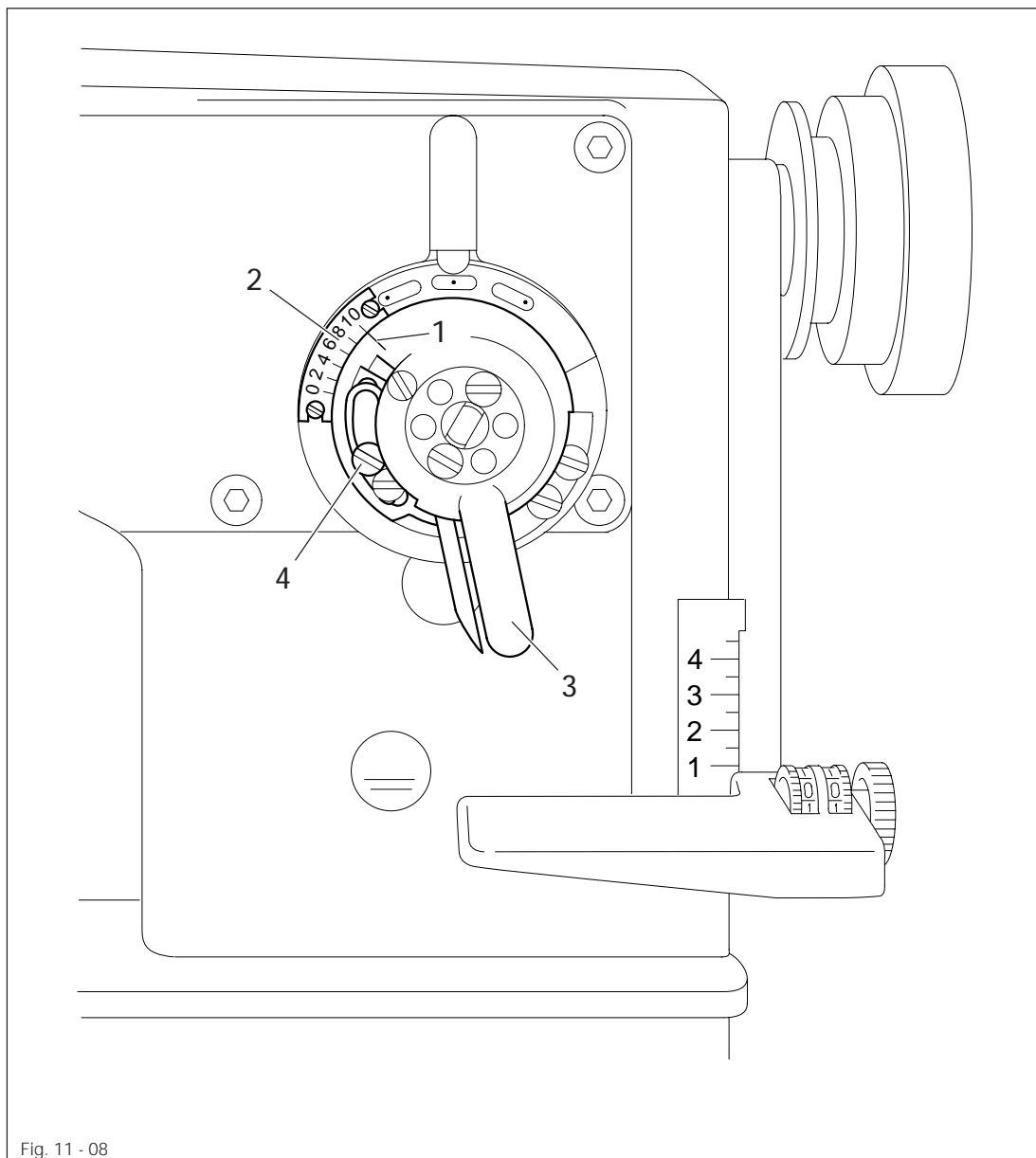

- Turn the zigzag stitch adjustment lever **3** in accordance with the **requirement**.
- Move screw **4** upwards until it touches and then tighten it.



If the machine is equipped with a needle plate with a smaller hole than is marked on the scale, the zigzag limit must be set according to the needle hole width on the needle plate.

11.05.08 Zigzag stitch motion

Requirement

When the needle bar is at tdc coming from the right bdc (hole 2), the needle bar must not move laterally when the zigzag stitch adjustment lever is moved back and forth.

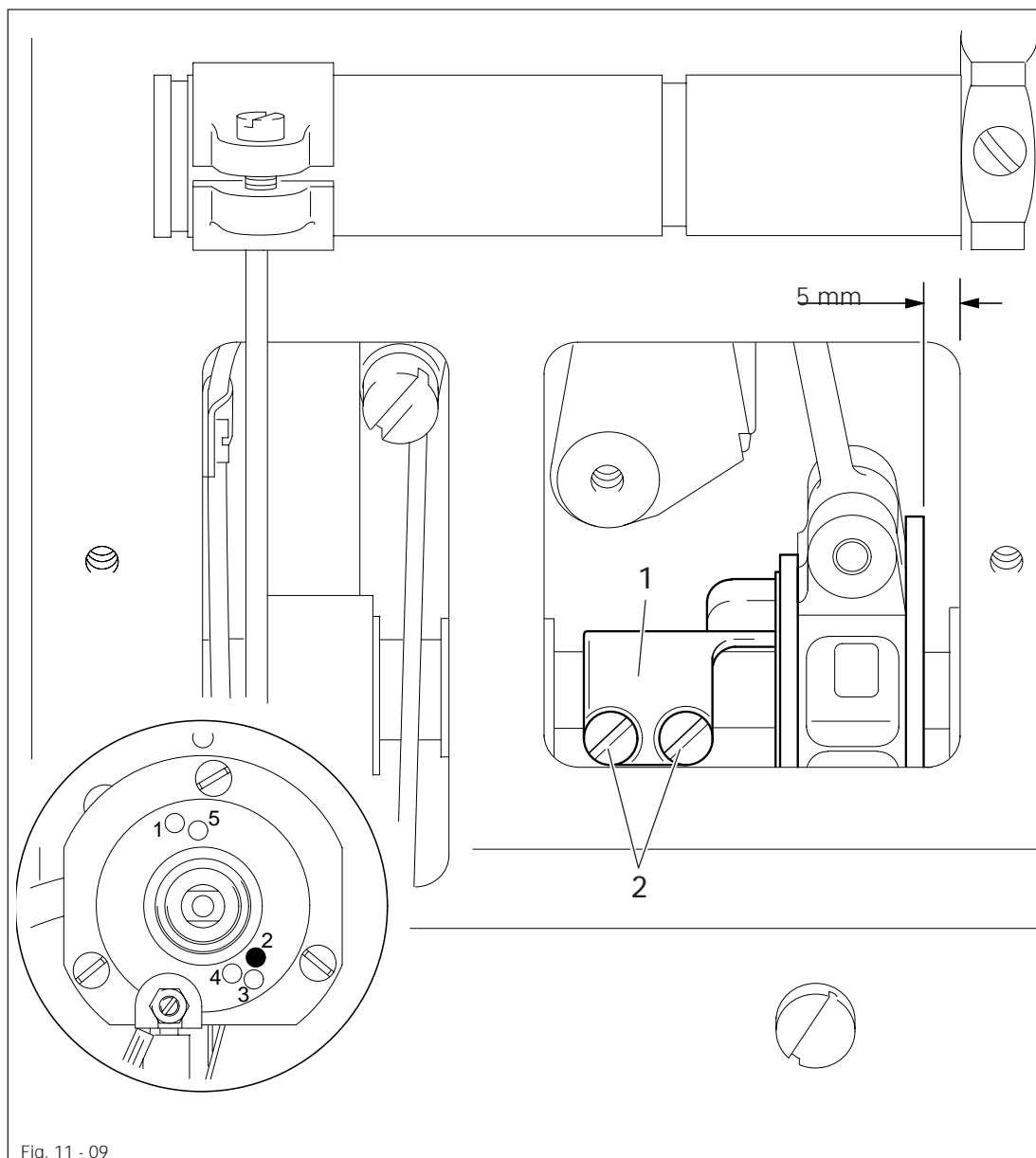
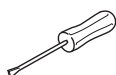

Fig. 11 - 09



- Loosen screws 2.
- Turn zigzag stitch eccentric 1 in accordance with the **requirement**, taking care to ensure that zigzag stitch eccentric 1 is approximately 5 mm from the inner right side of the housing wall.
- Tighten screws 2.

11.05.09 Needle penetration symmetry

Requirement

1. With the zigzag stitch setting at "0" the needle must enter the middle of the needle hole.
2. At the largest setting of the zigzag stitch the right and left needle-penetrations must be the same distance from the middle penetration.

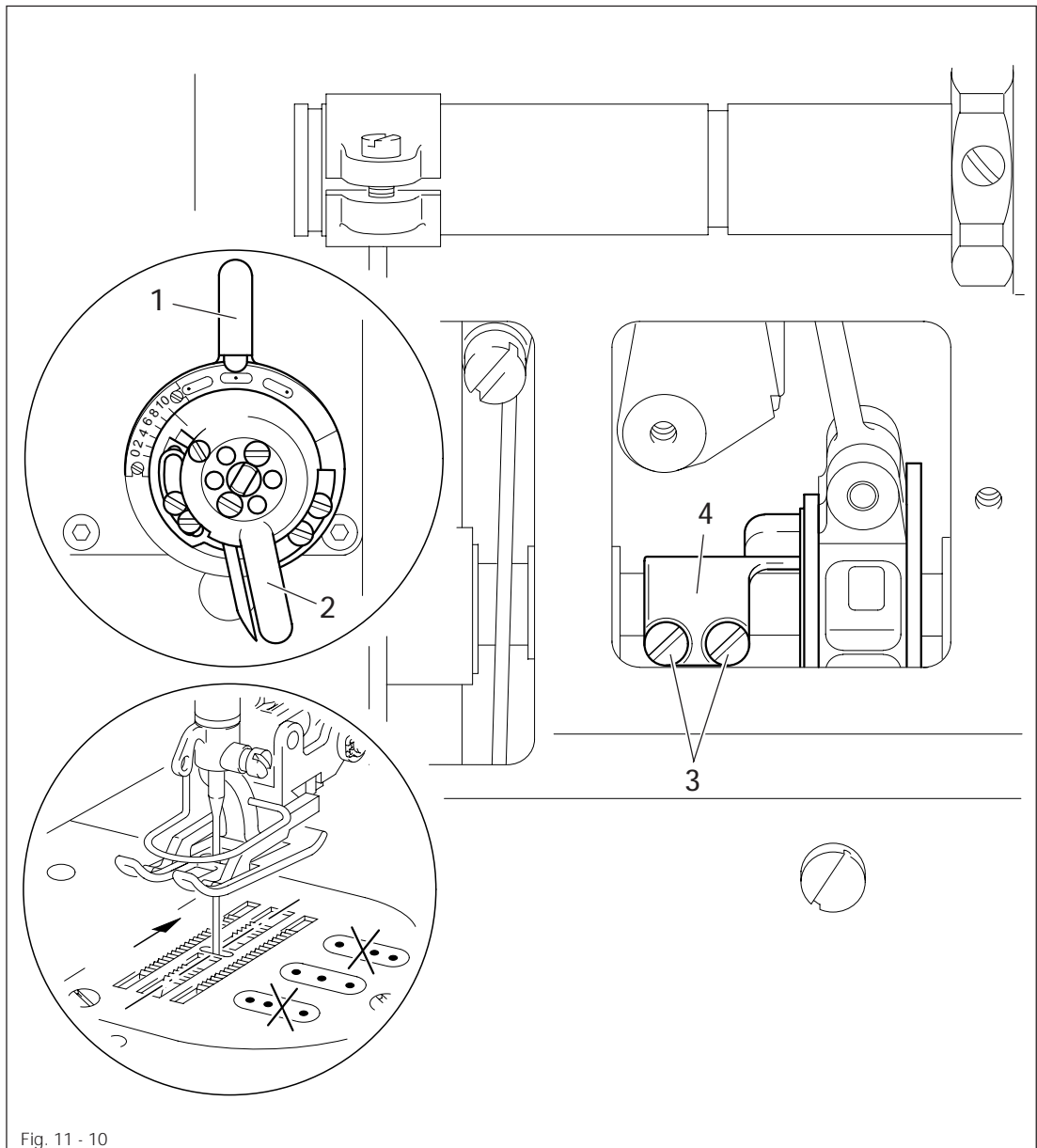
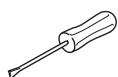

Fig. 11 - 10



- Move the needle position lever 1 to "middle" and the zigzag stitch adjustment lever 2 to "0".
- Place a piece of paper underneath the presser foot and perforate it with the needle.
- Raise the needle a little and set the zigzag stitch adjustment lever 2 to the largest setting.
- Perforate the paper to the right and left by turning the balancewheel back and forth.
- Loosen screws 3.
- Move zigzag stitch eccentric 4 in accordance with the **requirement** without twisting it and tighten screws 3.

11.05.10 Needle position adjustment lever

Requirement

The left and right throws of the needle must be the same size at the largest zigzag stitch setting and at the left or right needle position.

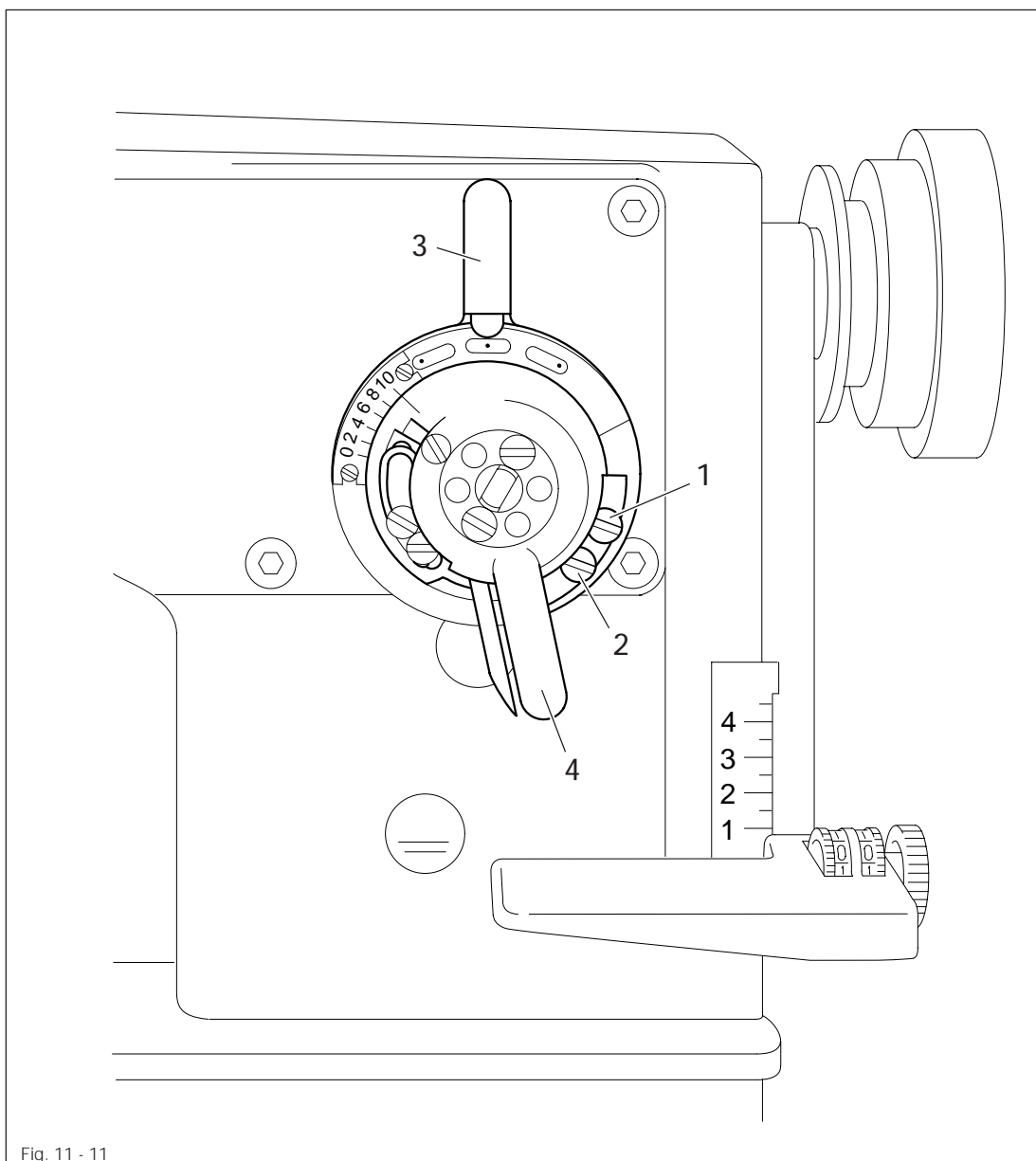
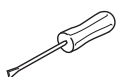

Fig. 11 - 11



- Loosen screws 1 and 2.
- Set the needle position adjustment lever 3 to "middle" and the zigzag stitch adjustment lever 4 at the largest zigzag stitch.
- Place a piece of paper underneath the presser foot and perforate it to the left and right with the needle.
- Set the zigzag stitch adjustment lever 4 at "0" and move the needle position adjustment lever 3 to the right/left until the needle is exactly over the perforations made in the last step.
- For the left needle-position bring screw 1 to a position where it touches and tighten it and for the right needle-position do the same with screw 2.

11.05.11 Adjustment wheels for applying fullness

Requirement

With guide pin 2 in the middle of the connecting link and the ends of the toothed racks 6 flush with each other, the zero markings on the adjustment wheels 5 must be at marking 4.

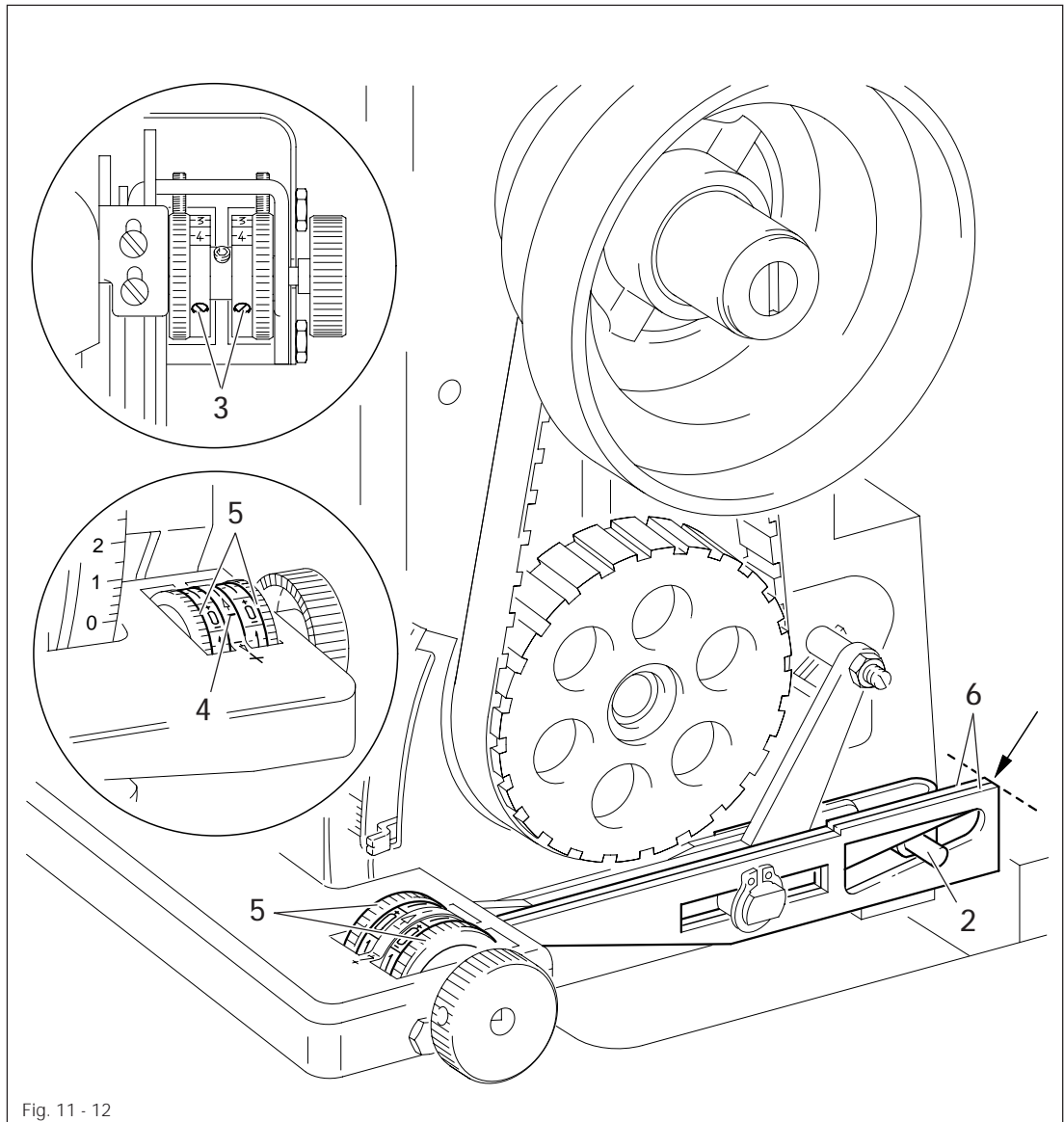
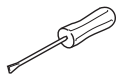

Fig. 11 - 12



- Loosen screws 3.
- Turn both adjustment wheels 5 until guide pin 2 is in the middle of the connecting link. The ends of the two toothed racks 6 must be flush with each other.
- Turn both scale rings in accordance with the **requirement** and tighten screws 3.

11.05.12 Zeroing the differentiation

Requirement

At the longest stitch-length setting, the reverse sewing button 11 must be at its highest position. In addition, the stop finger 8 of clamp crank 7 must be touching the upper regulating shaft.

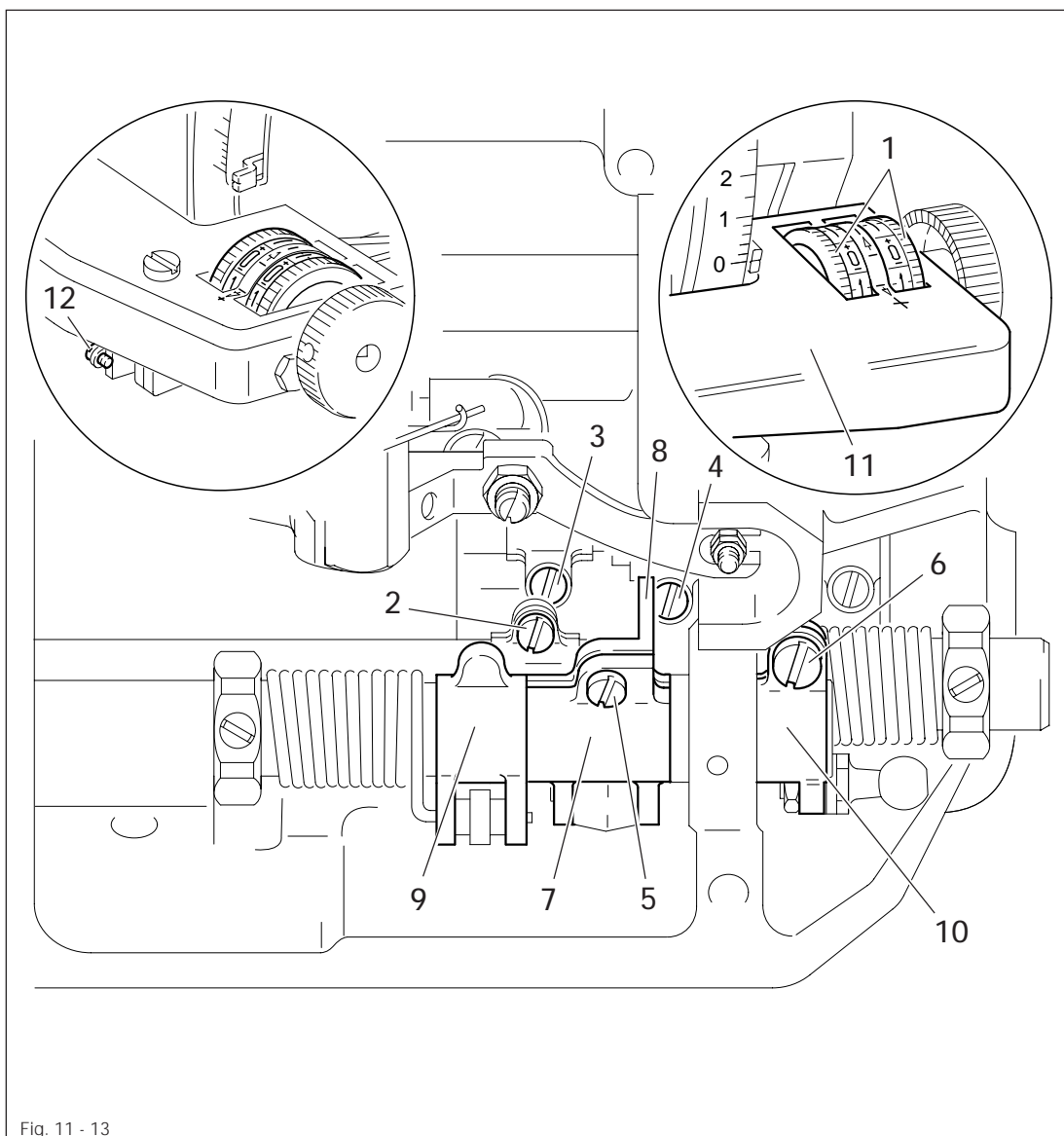
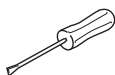

Fig. 11 - 13



- Unscrew screw 12 and the needle plate on machines with stitch length N24.
- Set both adjustment wheels 1 at "0".
- Loosen screws 2,3,4,5 and 6.
- Adjust reverse sewing key 11 and clamp crank 7 with stop finger 8 in accordance with the **requirement** and tighten screws 4 and 5.
- Turn clamp crank 9 until it is parallel with clamp crank 7, and tighten screws 2 and 3.
- Turn clamp crank 10 so that it is parallel with the bedplate and tighten screws 6.
- On machines with stitch length N24, tighten screw 12 and fit the needle plate.

Adjustment

11.05.13 Main-stitch-length display

Requirement

With the stitch length set at "0", pointer 4 must be exactly at the marking "0" on scale 5.

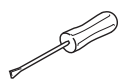
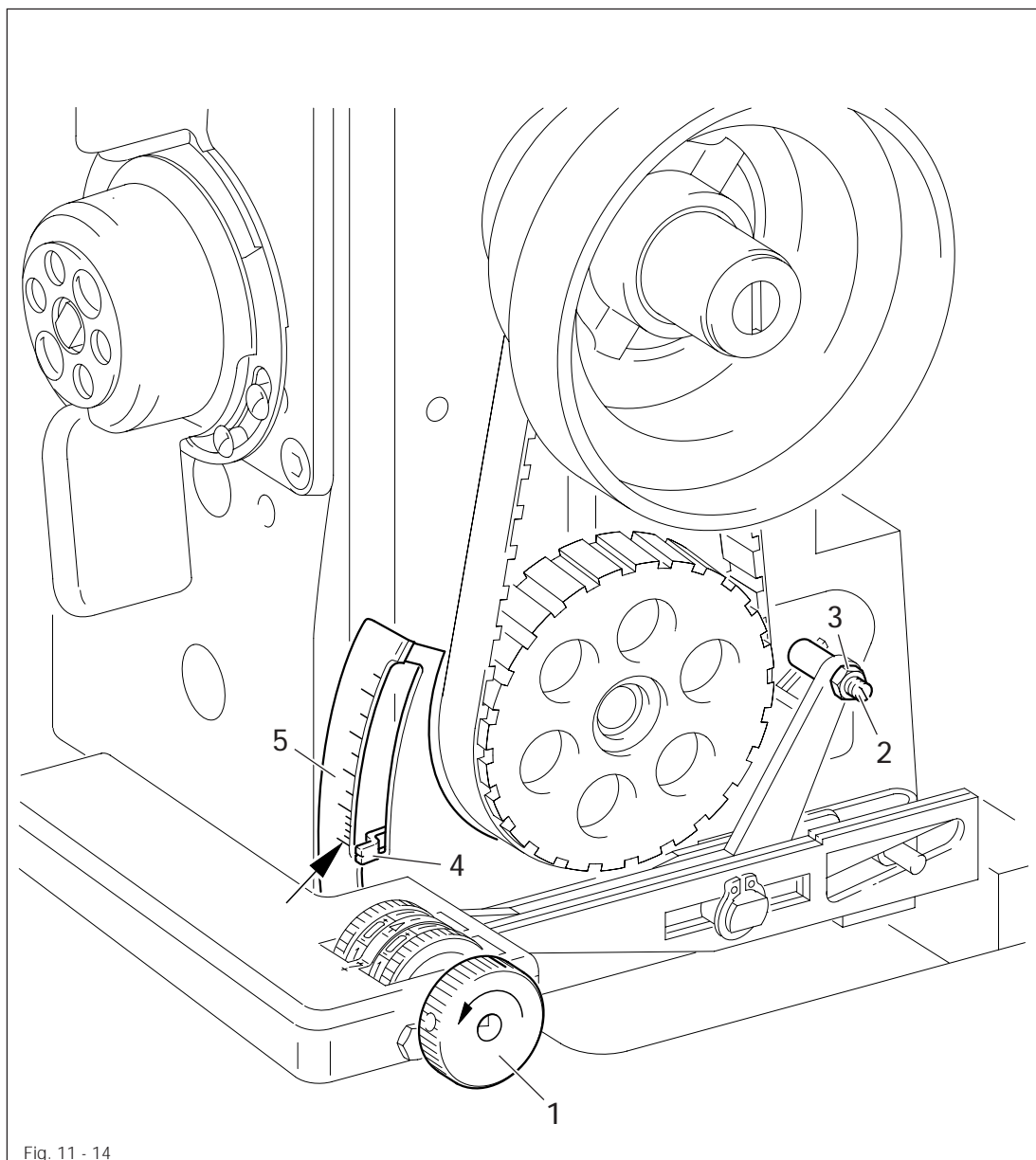

- Turn the stitch length adjustment wheel 1 as far as possible in the direction of the arrow.
- Loosen nut 3.
- Turn eccentric bolt 2 in accordance with the requirement.
- Tighten nut 3.

11.05.14 Zeroing the bottom feed (with gearbox housing closed)

Requirement

With the stitch length set at "0" the bottom feed dog must not carry out any feeding motion when the balance wheel is turned.

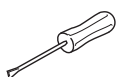
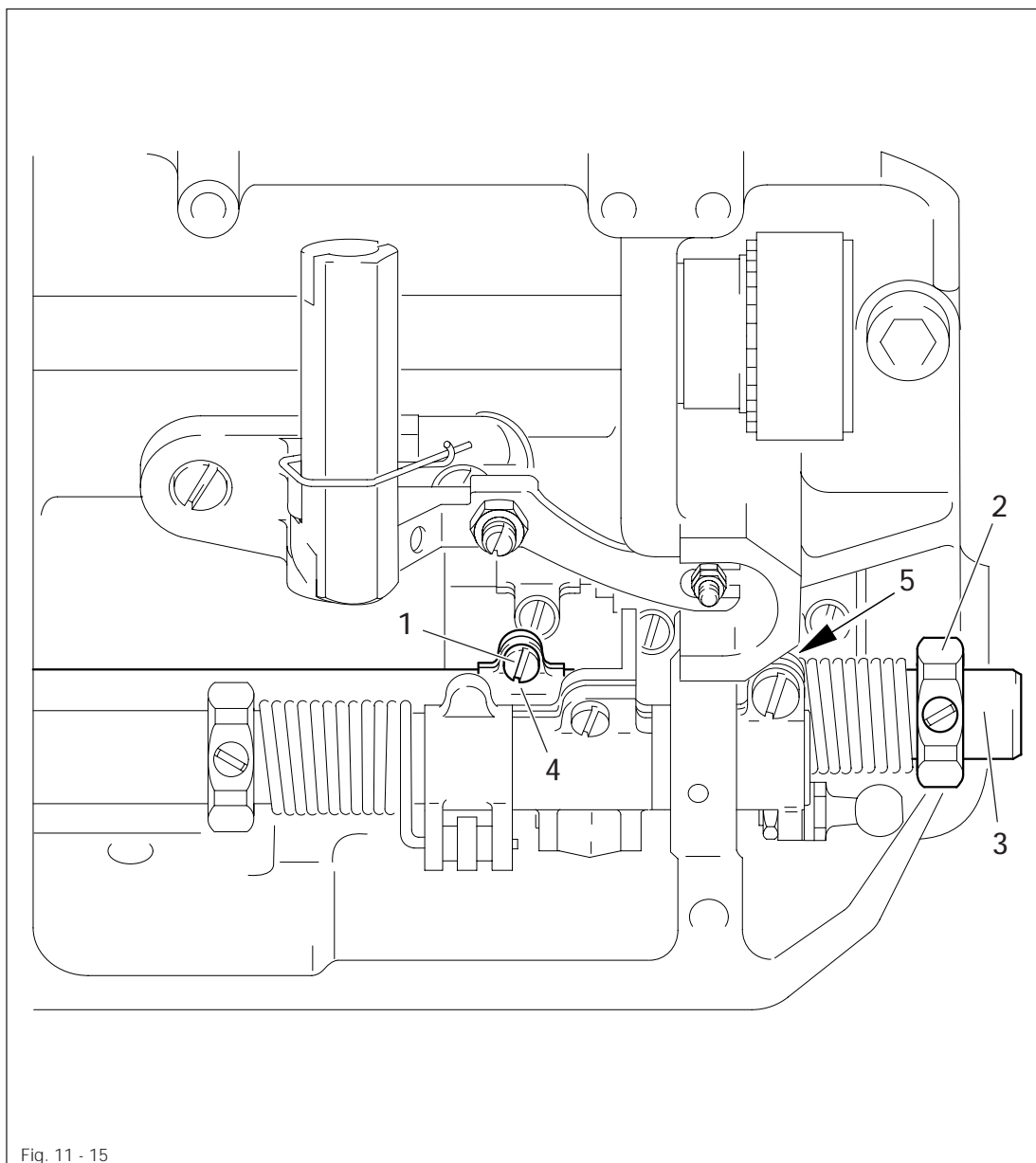

- Loosen screw 1.
- Place the open-ended wrench (SW 27) on torsion nut 2 and use it to hold regulating shaft 3 still.
- While continuously turning the balance wheel, turn the open-ended wrench on torsion nut 2 in accordance with the **requirement**.
- In this position move regulating crank 4 and circlip 5 so that they are touching the casting and tighten screw 1.
- Carry out a check in accordance with the **requirement**.

11.05.15 Zeroing the bottom feed (with gearbox housing open)

Requirement

With the stitch length set at "0" the bottom feed dog must not carry out any feeding motion when the balance wheel is turned.

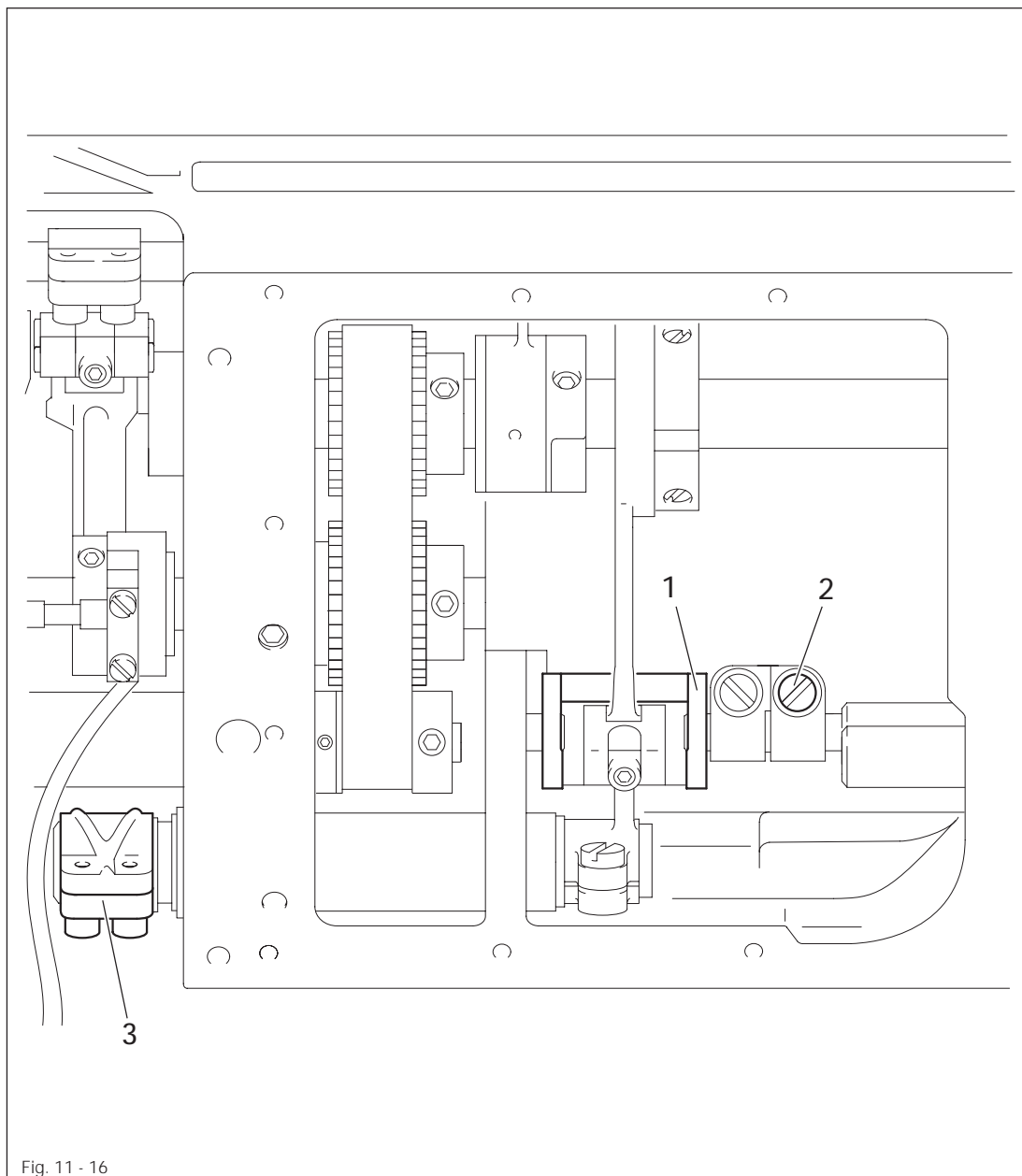
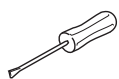

Fig. 11 - 16



- Loosen screw 2.
- While continuously turning the balance wheel, turn diverter crank 1 until feed driving crank 3 no longer moves.
- In this position tighten screw 2.
- Carry out a check in accordance with the **requirement**.

11.05.16 Vibrating presser connecting rod

Requirement

With the stitch length set at "0", crank 3 on vibrating presser connecting rod 1 must be horizontal.

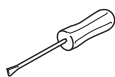
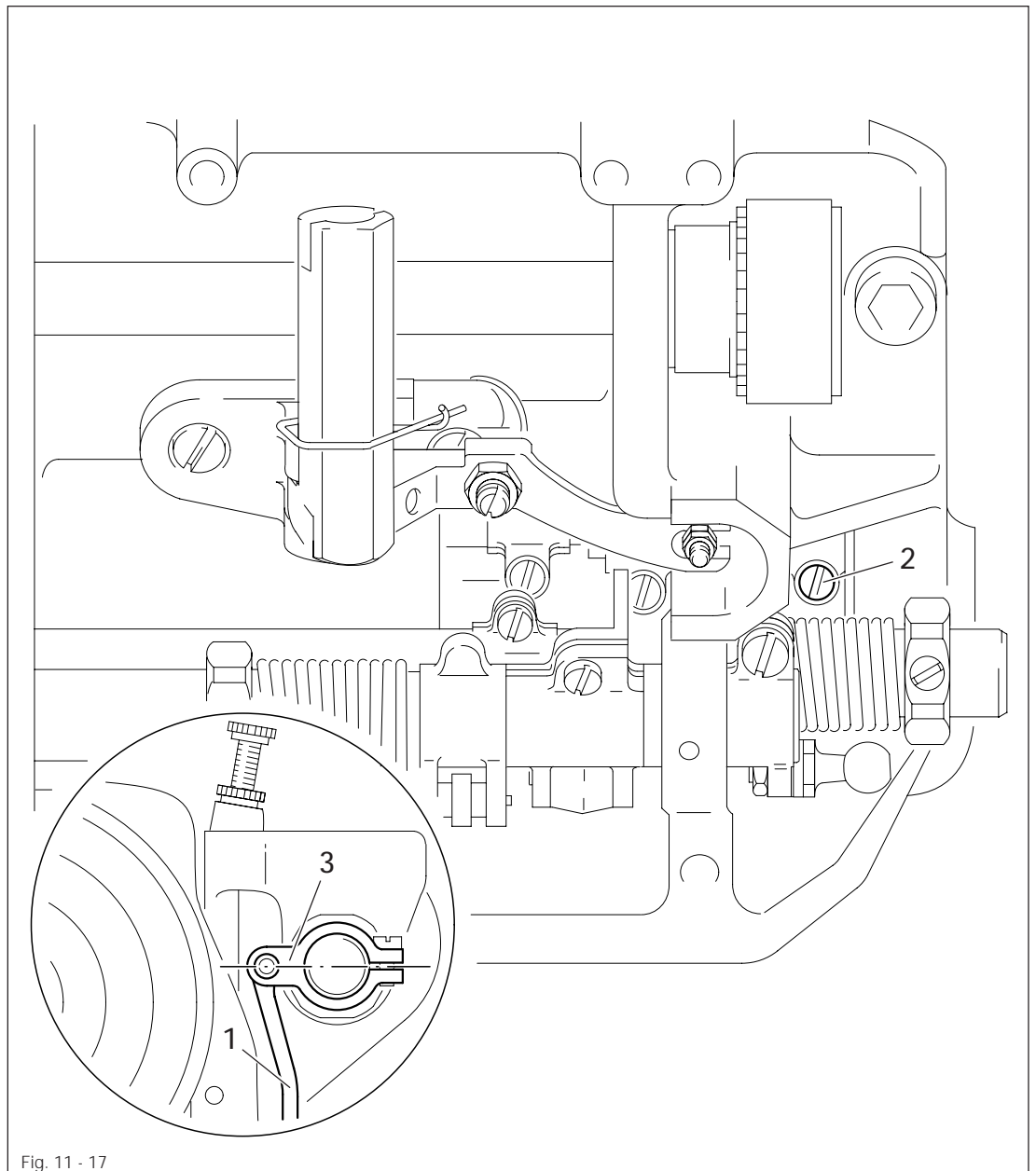

- Loosen screw 2.
- Move vibrating presser connecting rod 1 in accordance with the requirement.
- Tighten screw 2.

11.05.17 Zeroing the vibrating presser

Requirement

With the adjustment wheels 3 at "0" and the stitch length at "0", the vibrating presser must not carry out any feeding motion when the balance wheel is turned.

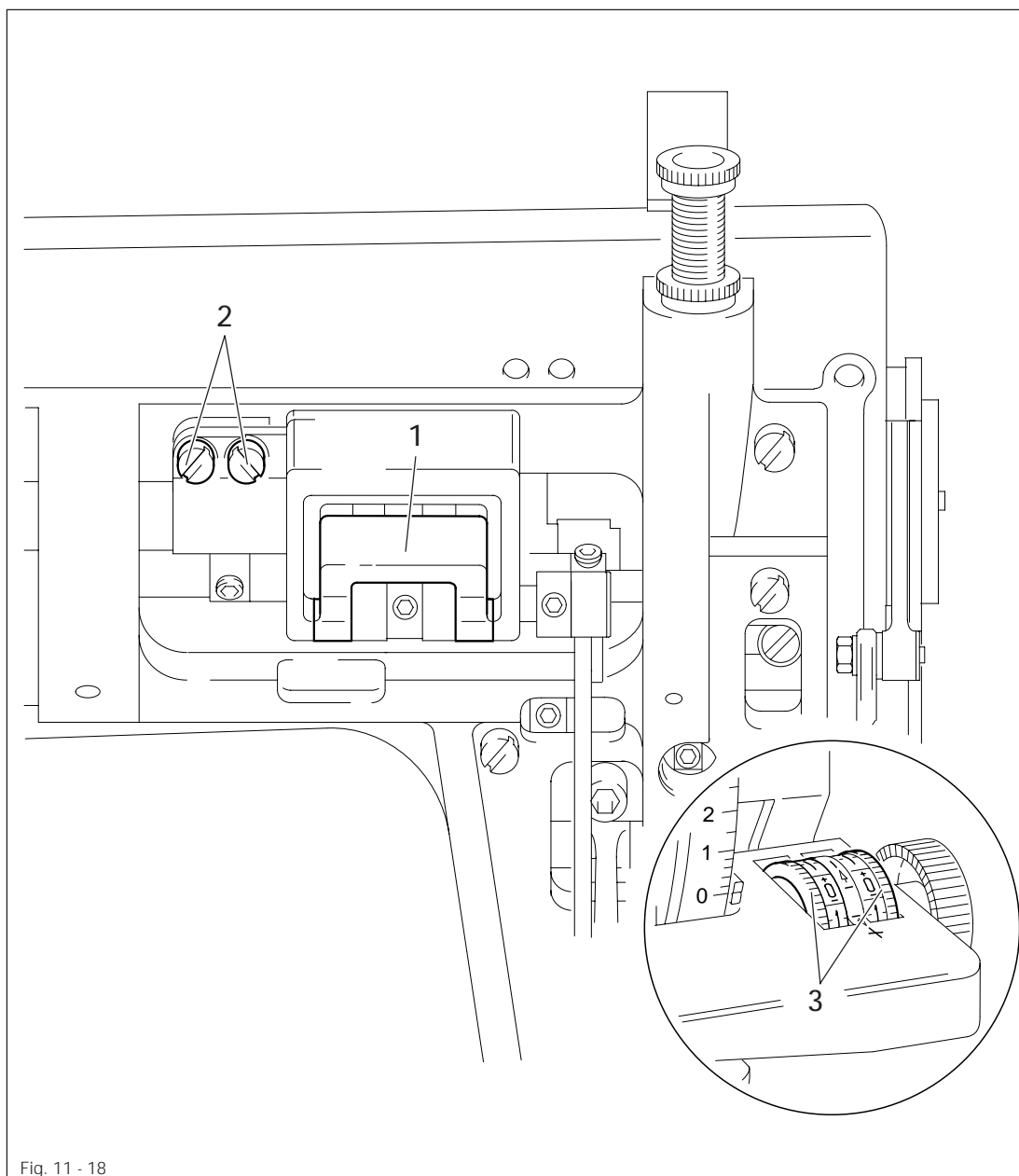
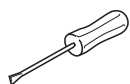

Fig. 11 - 18



- Loosen screw 2.
- Turn diverter crank 1 in accordance with the requirement.
- Tighten screws 2.

11.05.18 Torsion spring of the reverse feed lever

Requirement

With the presser foot raised, the longest stitch length set and the adjustment wheels 5 at "0", the reverse feed lever 4 must return automatically to its uppermost point after being activated.

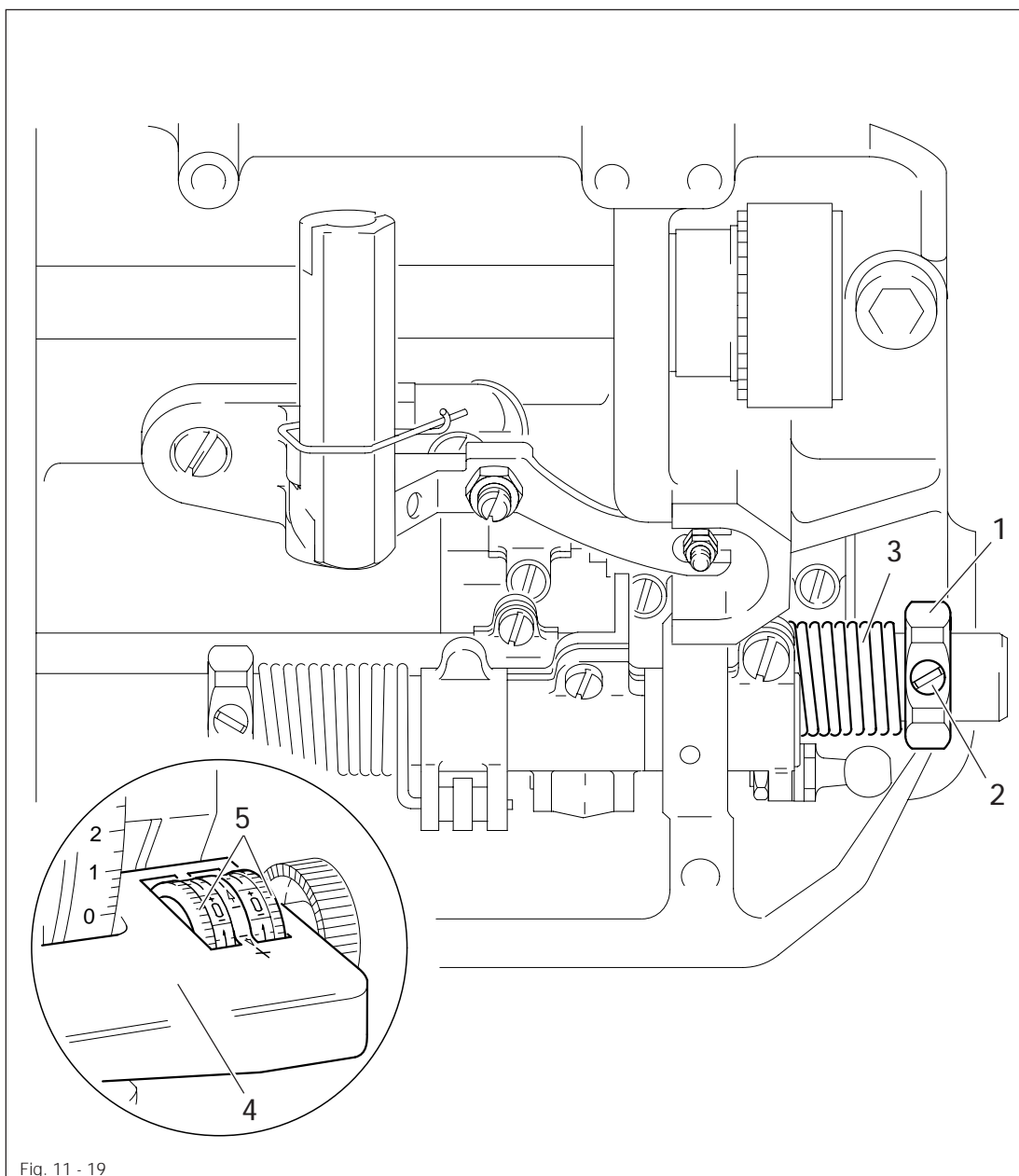
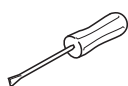

Fig. 11 - 19



- Loosen screw 2 a little.
- Turn torsion spring 3 in accordance with the requirement using nut 1.
- Tighten screw 2.

Adjustment

11.05.19 Torsion spring of the differentiation regulating shaft

Requirement

With the presser foot raised, the stitch length set at "0", adjustment wheel 3 at + 4.5 and adjustment wheel 4 at "0", guide pin 1 must be touching in connecting link 2.

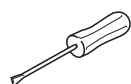
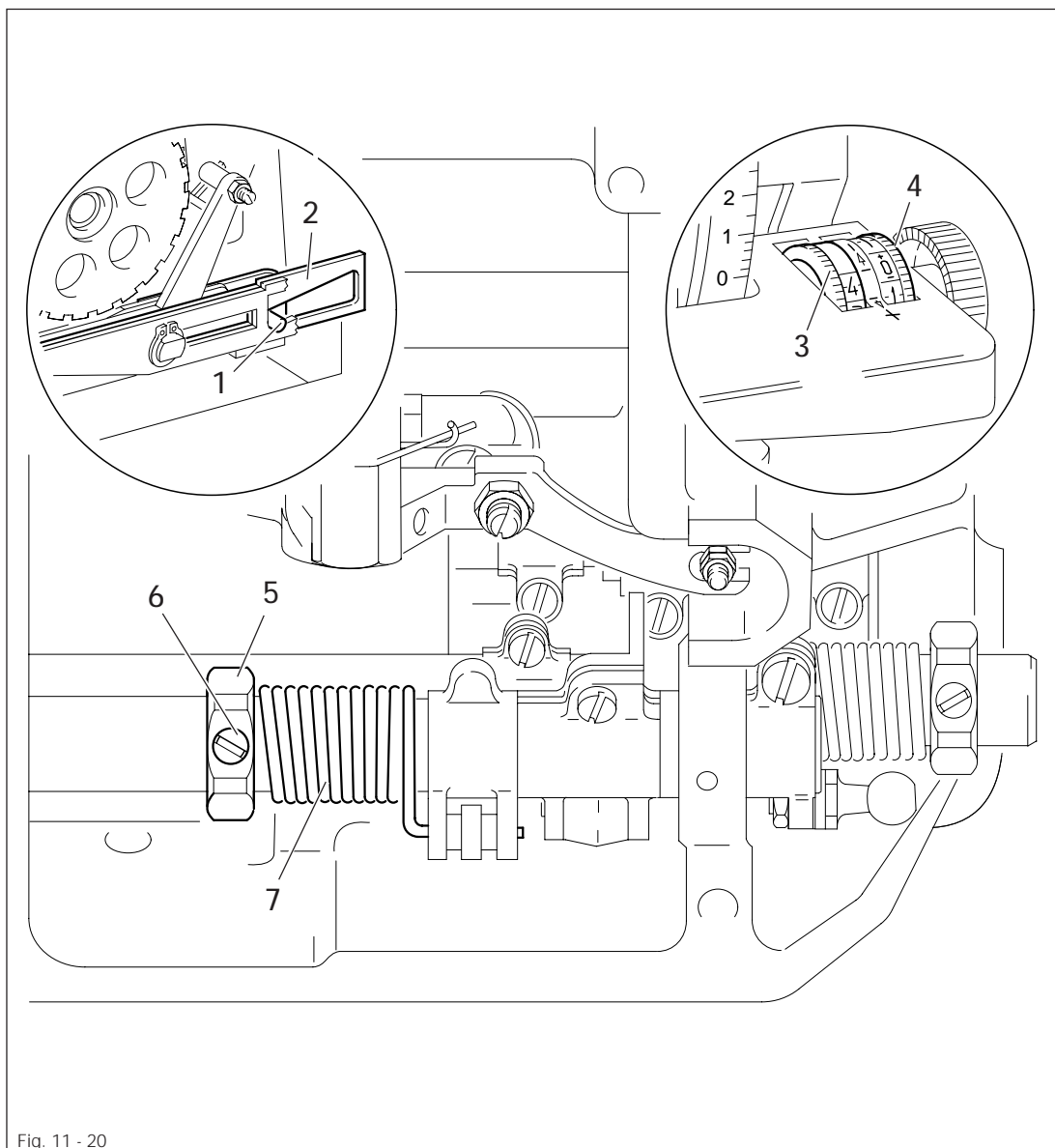

- Loosen screw 6 a little.
- Turn torsion spring 7 in accordance with the requirement using nut 5.
- Tighten screw 6.

11.05.20 Feeding motion of the bottom feed dog

Requirement

With the maximum stitch length set and the needle bar position 1.0 past tdc (hole 4), the bottom feed dog must not move when the reverse feed lever is pressed.

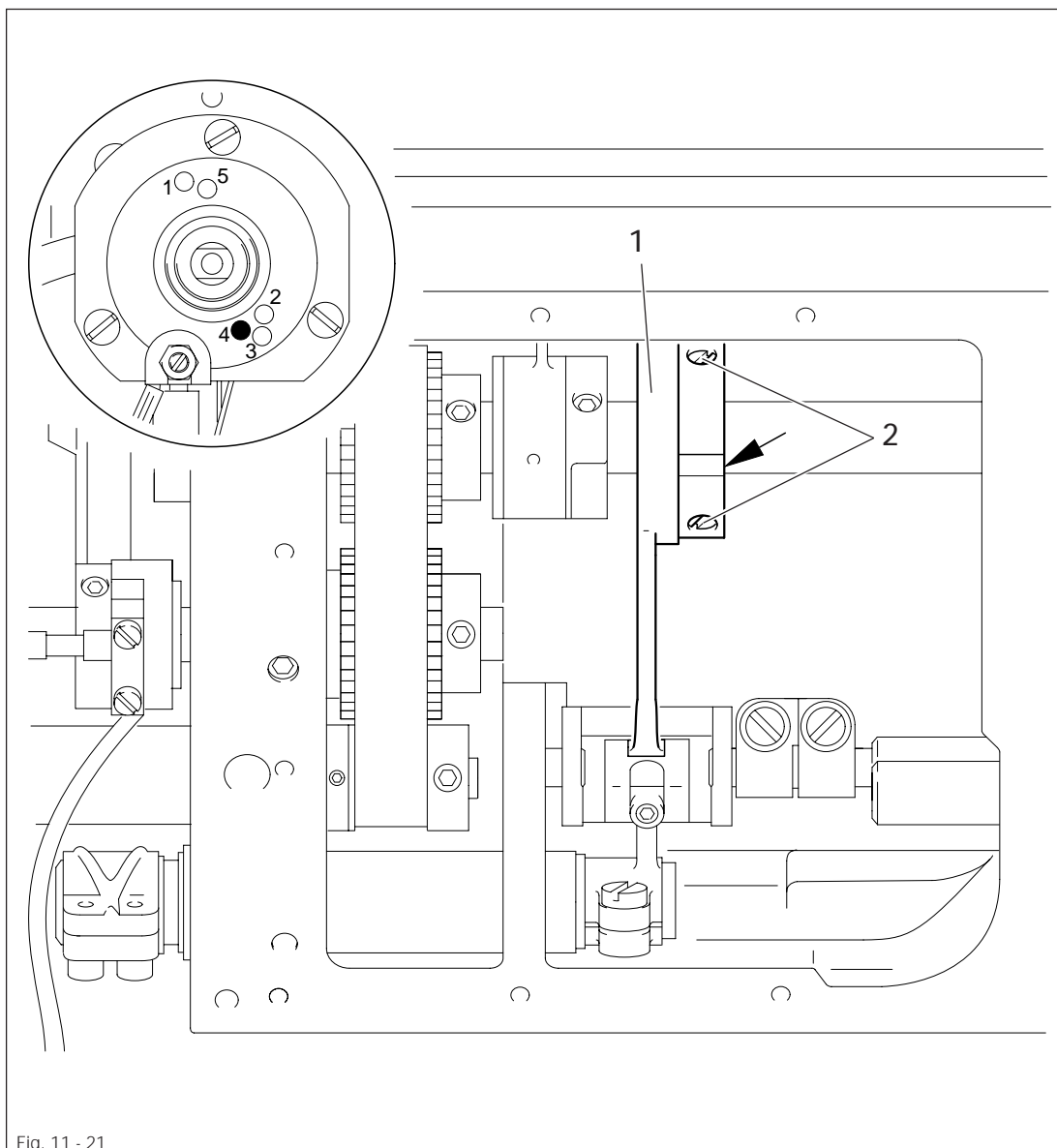
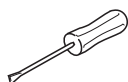

Fig. 11 - 21



- Loosen screws 2.
- Turn feeding eccentric 1 in accordance with the **requirement** while holding the reverse feed lever pressed (The notch in feed eccentric 1 must be visible).
- Tighten screws 2.



The feeding eccentric 1 must not be moved axially.

11.05.21 Lifting motion of the bottom feed dog

Requirement

With the stitch length set at "0" and the needle bar position at 0.25 mm past tdc (hole 3) the bottom feed dog must be at its upper point of reversal.

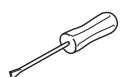
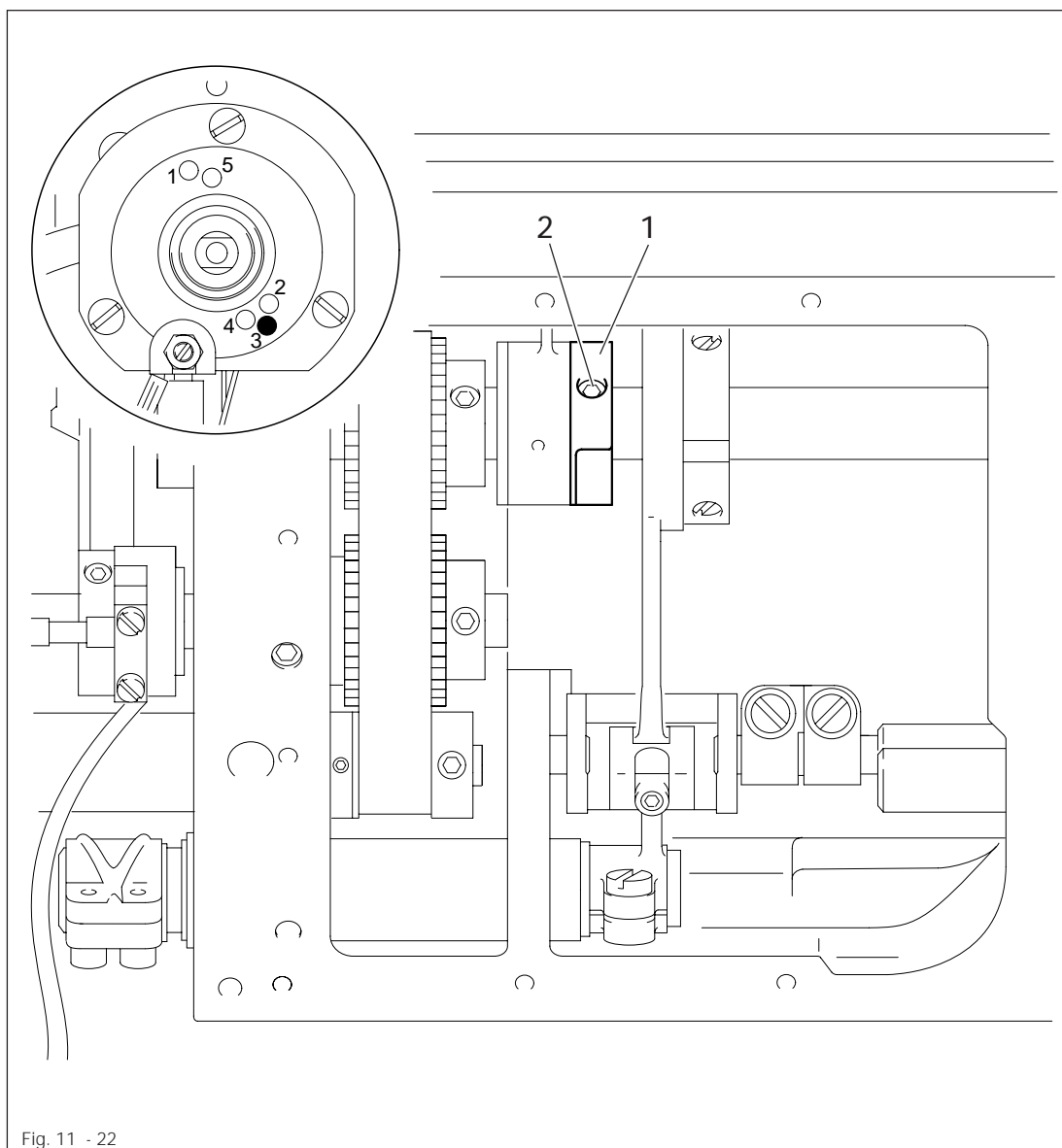

- Loosen screw 2.
- Turn lifting eccentric 1 in accordance with the **requirement**.
- Tighten screw 2.



Lifting eccentric 1 must not be moved axially.

11.05.22 Drive belt in the gearbox housing

Requirement

Drive belt 4 must be tightened so that the machine runs freely and the belt sprockets do not have any noticeable play.

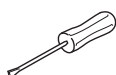
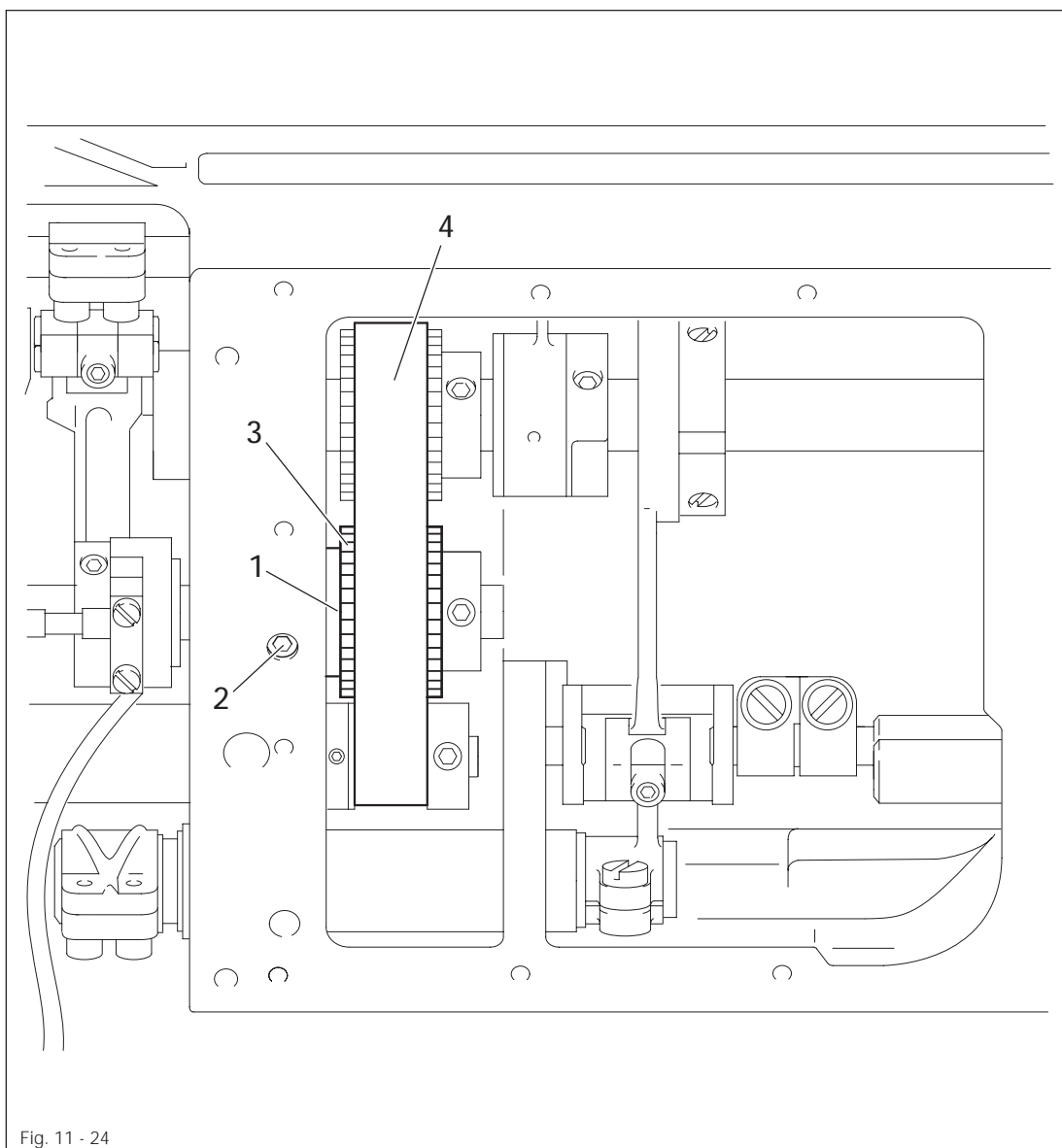

- Loosen screw 2.
- Move eccentric bearing bush 1 until drive belt 4 is in the middle of bobbin case opener drive wheel 3 and turn it in accordance with the requirement.
- Tighten screw 2.

11.05.23 Hook bearing bracket

Requirement

The hook shaft must be touching the hook bearing bracket adjustment gauge 1 at the top and the side.

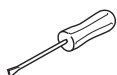
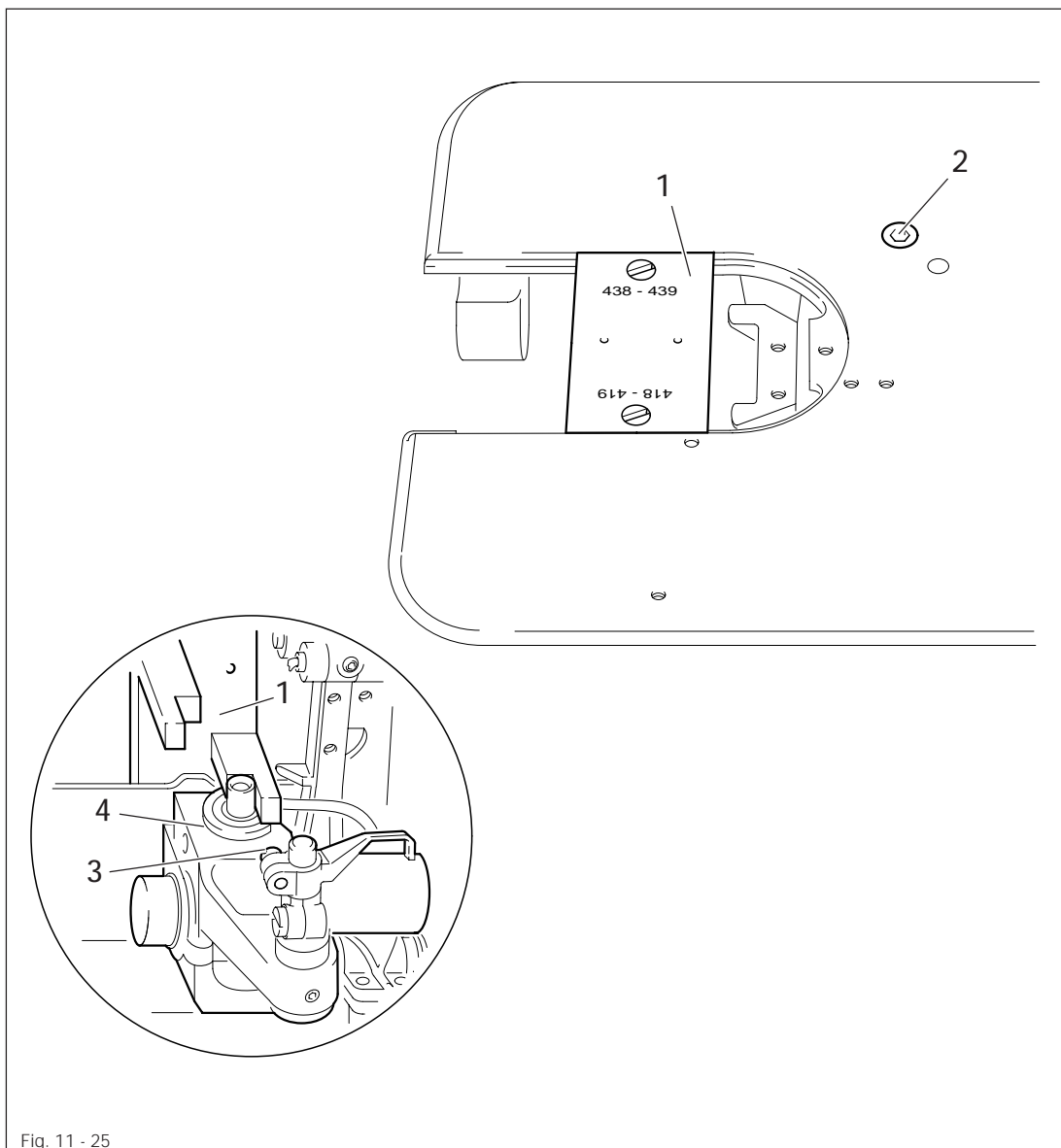

- Loosen screw 3.
- Swing the bobbin case opener to the right and remove the hook.
- Loosen screw 2 and loosen the draw key underneath it by lightly tapping the head of the screw.
- Screw on the hook bearing bracket adjustment gauge.
- On the PFAFF 937 the numbers "438 - 439" must be visible from the front.
- Move or turn hook bearing bracket 4 in accordance with the requirement.
- Tighten screw 2.
- Adjust the bobbin case opener in accordance with subsection 11.05.28 Bobbin case opener position.

11.05.24 Hook lubrication

Requirement

1. Centrifuge disc 2 must be 1.5 mm in front of the oil thrower.
2. With the machine working at top speed, a fine stripe of oil should appear after about 10 seconds on a piece of paper held over the needle plate cutout.

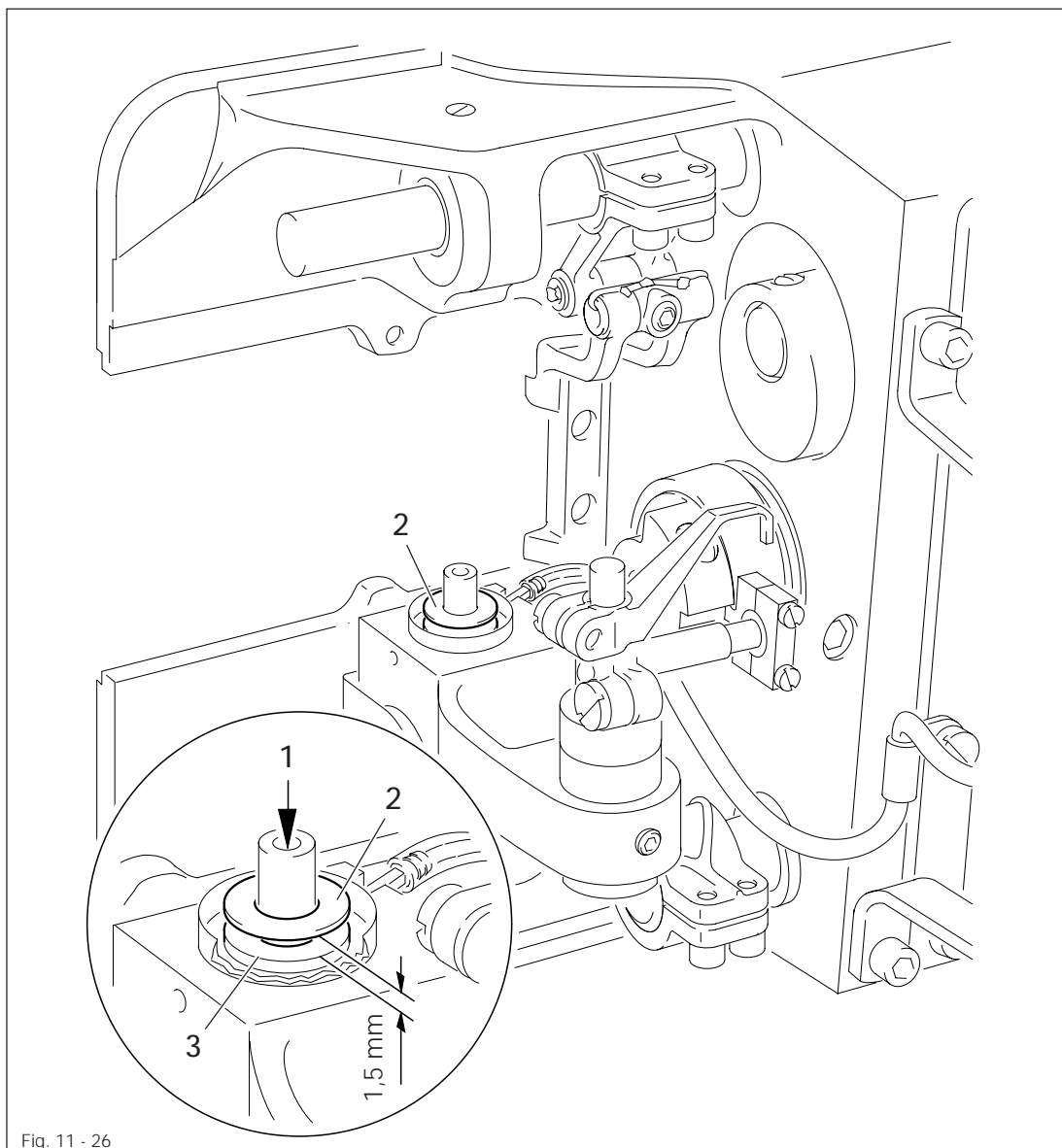

This setting is only necessary when the wick has been replaced. when replacing the wick, ensure that the new wick is saturated with oil.

- Loosen screw 1.
- Move centrifuge disc 2 in accordance with requirement 1.
- Tighten screw 1.
- Check requirement 2 and move centrifuge disc 2 if necessary.

Adjustment

11.05.25 Pre-adjusting the needle height

Requirement

With the needle bar at tdc (hole 2) the distance between the point of the needle and the needle plate must be **19 mm**.

- Loosen screws 1.

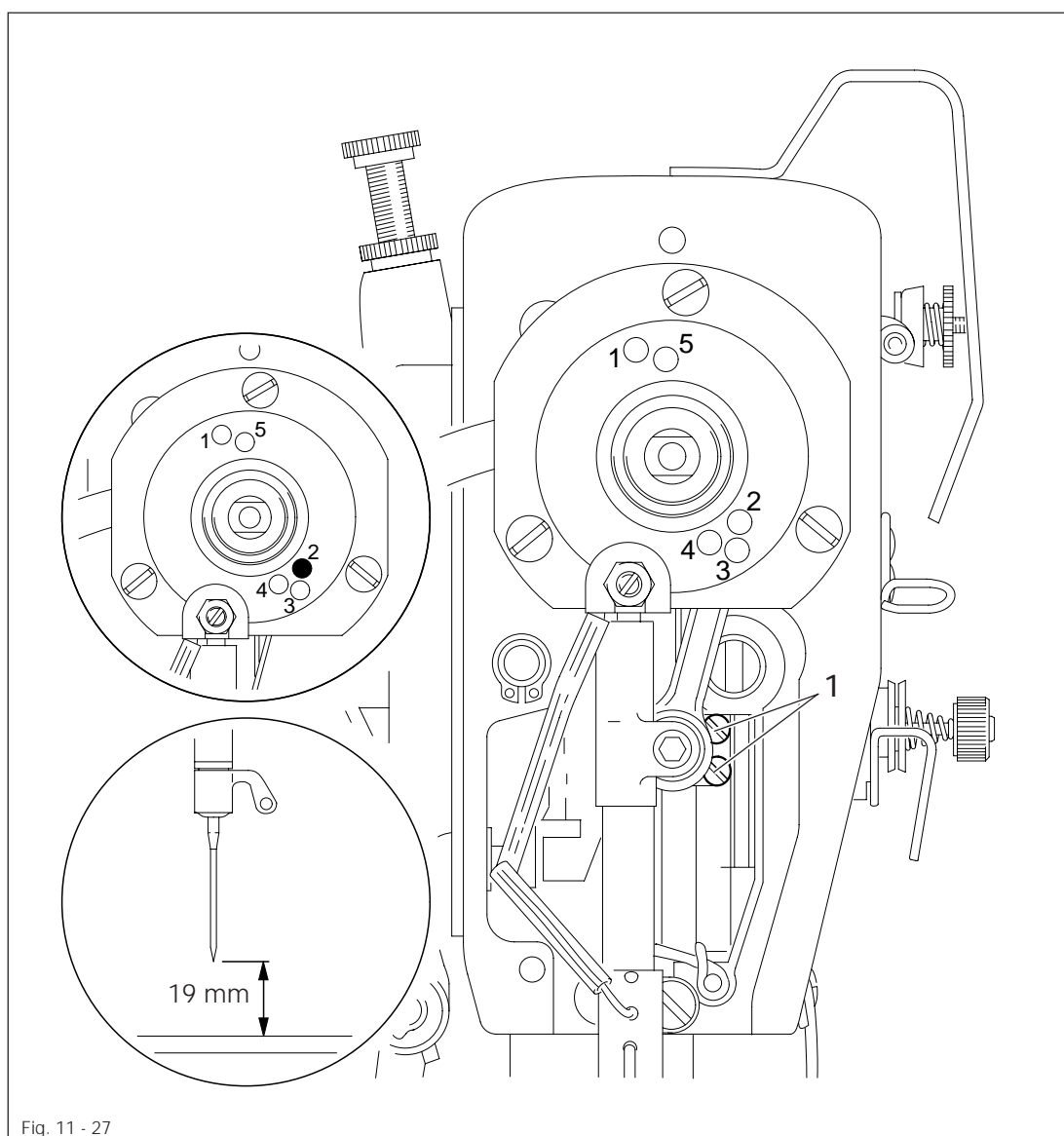
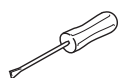

Fig. 11 - 27



- Move the needle bar in accordance with the **requirement** without twisting it.
- Tighten screws 1.

Requirement

1. With the needle position set at "middle", the zigzag stitch setting at "0" and the needle bar position 2.0 past bdc (hole 1) the hook point must be in the middle of the needle and the distance between the needle and the hook point must be 0.05 - 0.1 mm.
2. The bobbin case positioning-finger must be fitted so that there is a clearance of 0.5 mm between the bottom section of the bobbin case and the front edge of the bobbin case positioning-finger (see arrow).

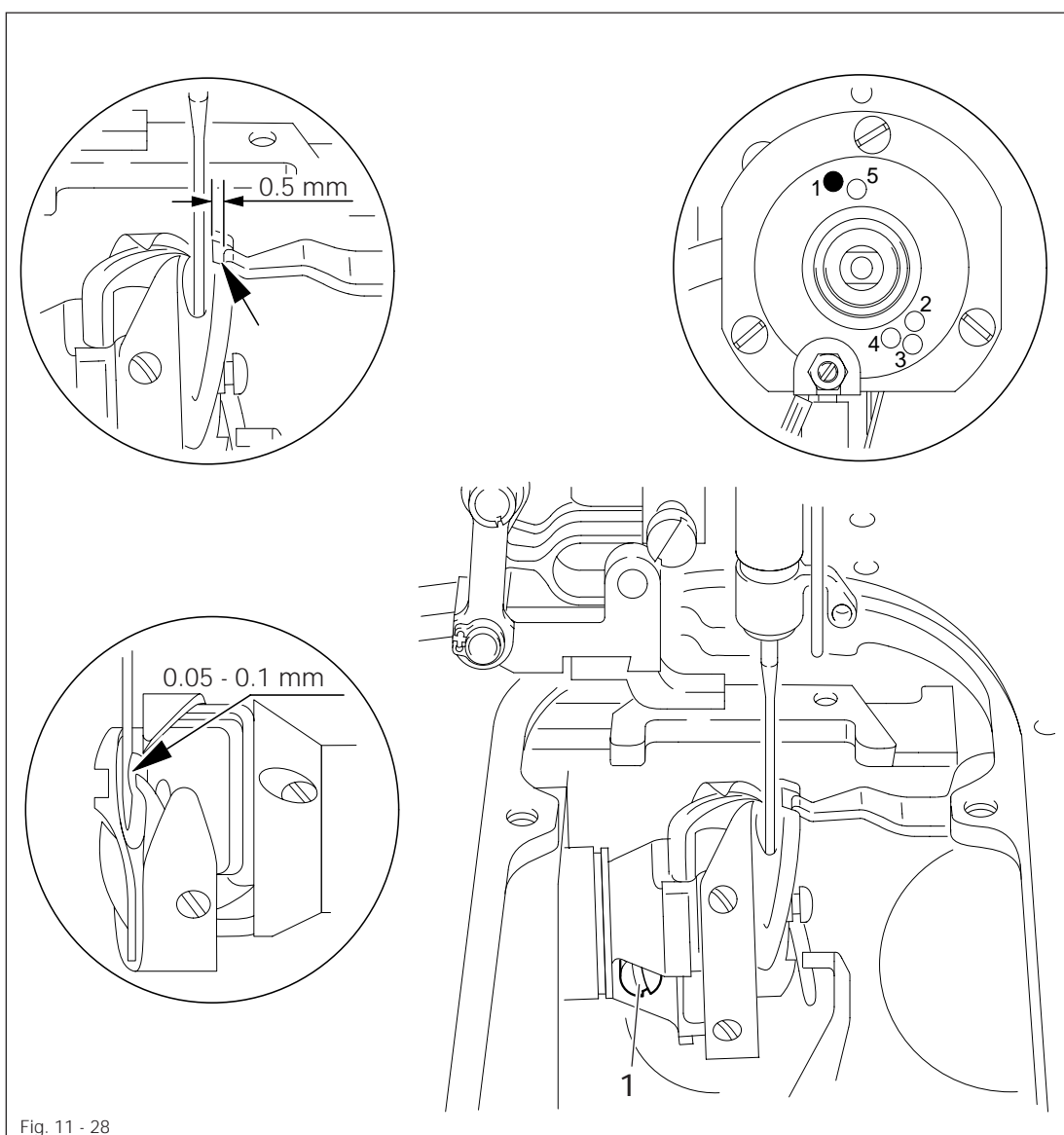
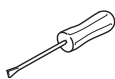

Fig. 11 - 28

- Loosen screw 1.
- Adjust the hook in accordance with **requirement 1**.
- Fit the bobbin case positioning-finger in accordance with **requirement 2**.
- Tighten screw 1.



11.05.27 Final adjustment of the needle height

Requirement

With the zigzag stitch set at "0", the needle position set at "left" and the hook point in the middle of the needle, the top edge of the needle eye must be 0.5 mm underneath the hook point.

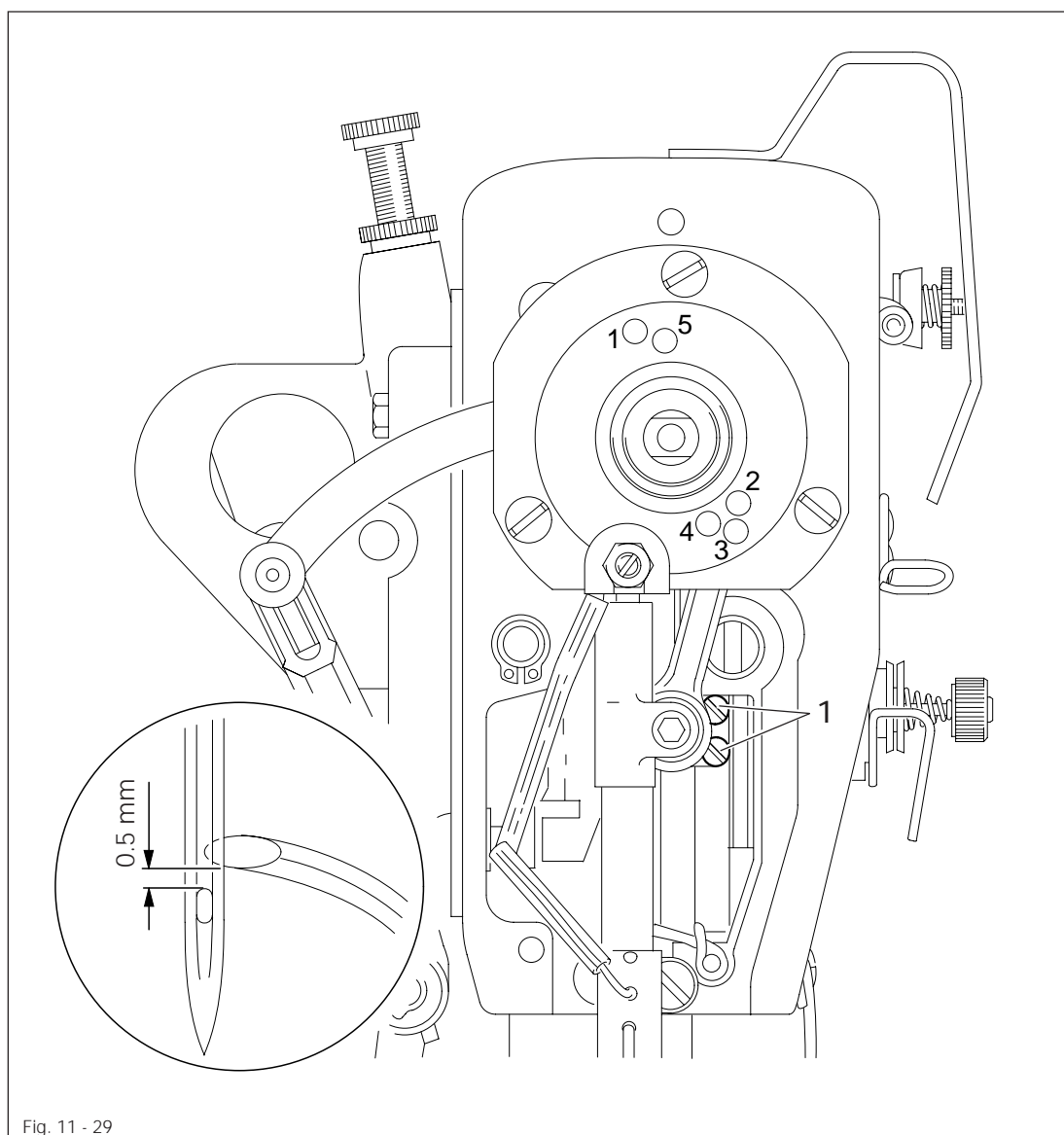
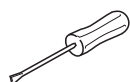

Fig. 11 - 29



- Loosen screws 1.
- Move the needle bar in accordance with the **requirement** without twisting it.
- Tighten screws 1.

Requirement

1. There must be a clearance of **0.5 mm** between the top edge of the bobbin case opener and the inner edge of the bottom section of the bobbin case.
2. Between the bobbin case opener finger and the bottom section of the bobbin case opener there must be a clearance of **0.8 mm**.
3. At the left point of reversal of the bobbin case opener the bobbin case positioning-finger must be approx. **0.3 mm** from the right side of the groove in the bottom section of the bobbin case.

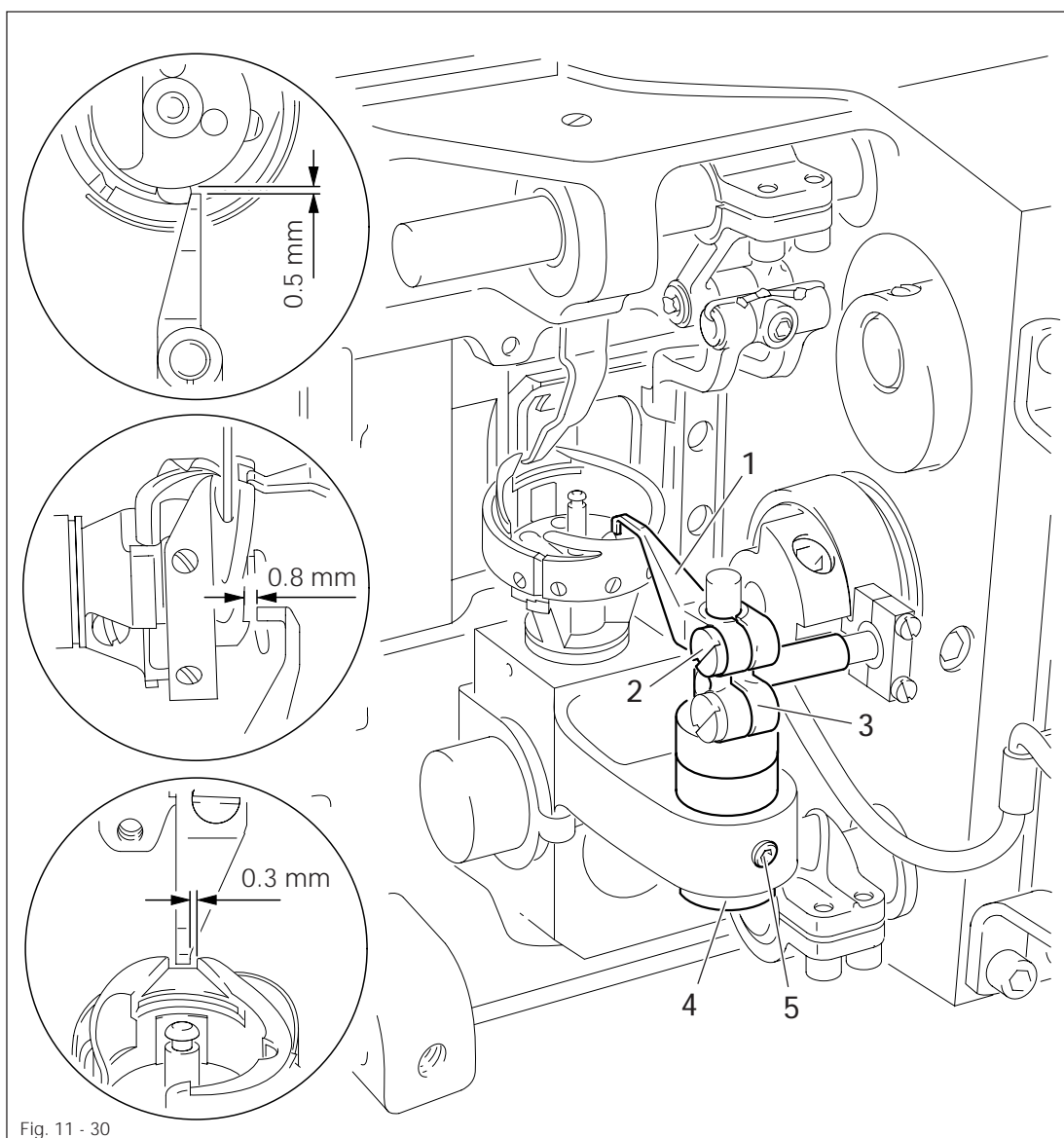

Fig. 11 - 30

- Loosen screw 2.

- Place bobbin case opener 1 onto the right side of the bottom section of the bobbin case, press against clamp crank 3 and lightly tighten screw 2.

- Loosen screw 5, move eccentric bearing bush 4 in accordance with requirements 1 and 2 and tighten screw 5.

- Turn bobbin case opener 1 in accordance with requirement 3 and tighten screw 2, taking care to ensure that bobbin case opener 1 is touching clamp crank 3.

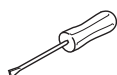

Adjustment

11.05.29 Bobbin case opener motion

Requirement

With the needle bar 2.0 past bdc (hole 1) the bobbin case opener 3 must be at its right point of reversal.

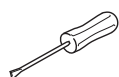
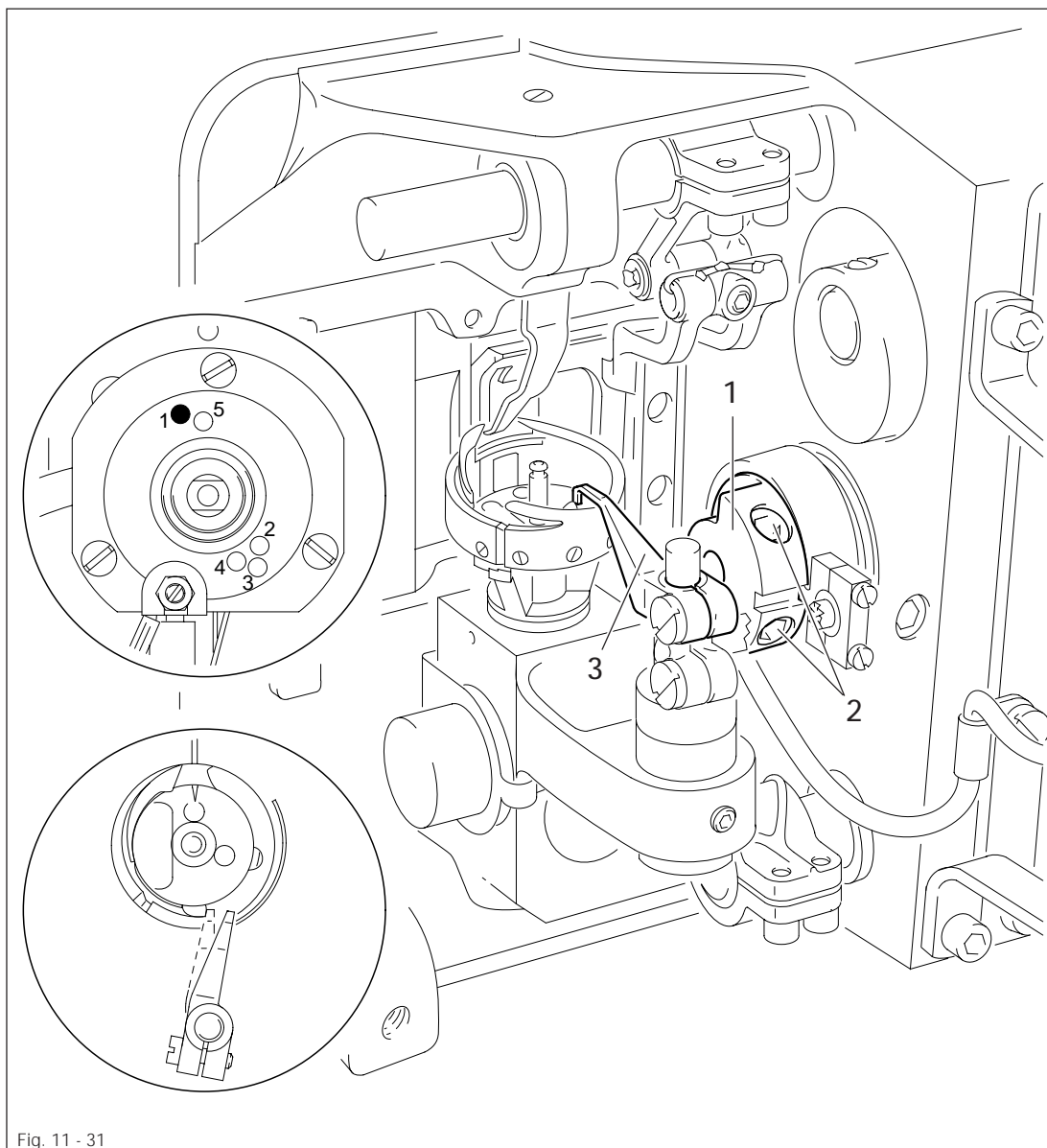

- Loosen screws 2.
- Turn bobbin case eccentric 1 in accordance with the requirement.
- Tighten screws 2.

11.05.30 Bottom feed dog height

Requirement

With the stitch length set at "0" and the needle bar position at 0.25 past tdc (hole 3) the bottom feed dog must be in the middle of the needle plate cutout and be touching the feed dog height-adjustment gauge along its entire length.

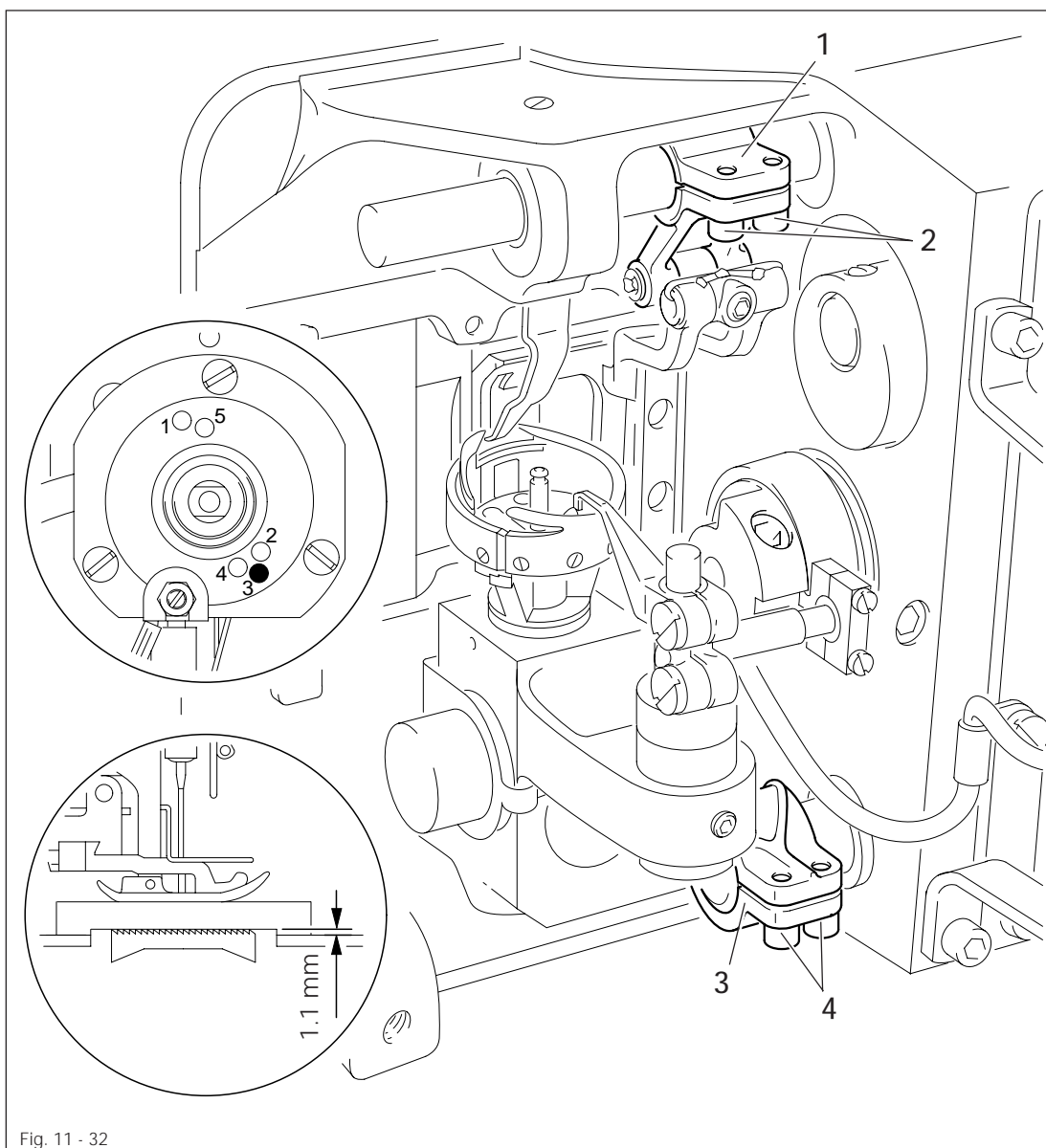
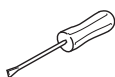

Fig. 11 - 32



- Position the feed dog adjustment gauge underneath the presser foot with the cutout facing downwards.
- Lower the presser foot onto it.
- Loosen screws 2 and 4
- Press the feed dog carrier up and position the feed dog in the middle of the needle plate cutout.
- Turn lifting crank 1 and clamp bush 3 in accordance with the requirement.
- Tighten screws 2 and 4.

Requirement

With the hand lever raised the needle must enter exactly in the middle of the needle hole in the presser foot and the clearance between the needle plate and the presser foot must be 7 mm.

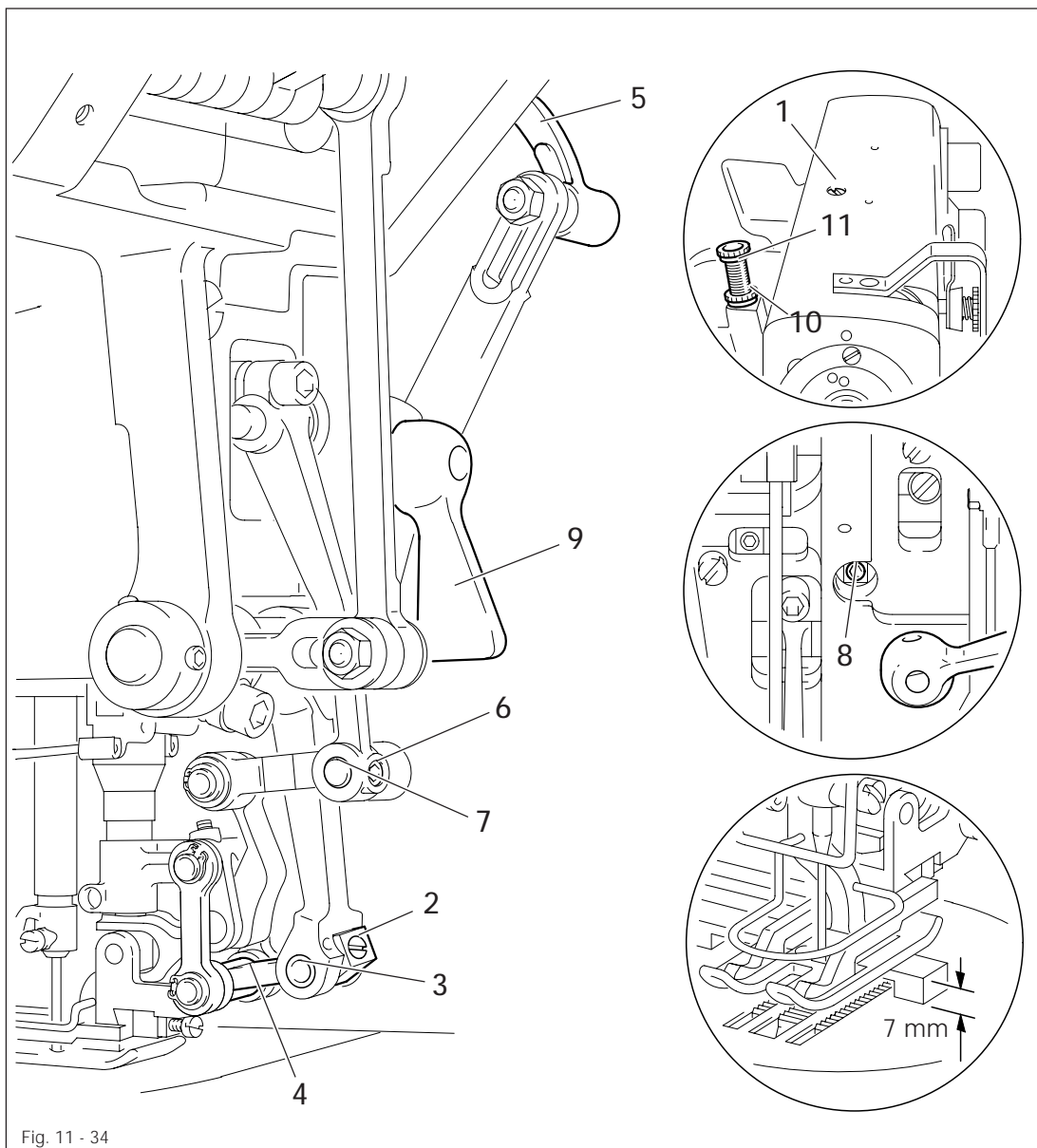
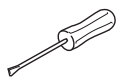
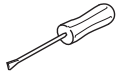

Fig. 11 - 34

- Set the zigzag stitch lever at "0" and the needle position adjustment lever at "middle".
- Allow the presser foot to rest on the needle plate. Loosen nut 10 and reduce the presser on the presser foot bar by turning screws 1 and 11.
- Tighten nut 10.
- Loosen screw 2. Push out pin 3 and pivot connecting joint 4 out of the fork of the feed lever.
- Bring lever 5 to its outer point of reversal.
- Place the feed dog adjustment gauge underneath the presser foot with its notch facing downwards.





- Loosen screw 6 and press out eccentric pin 7.
- Loosen screw 8 and raise hand lever 9.
- Press the presser foot lifting finger downwards and tighten screw 8.



For the following adjustments, screws 2 and 6 remain loosened and bearing bolt 3, connecting link 4 and eccentric pin 7 are not refitted.

11.05.32 Vibrating presser feed and connecting lever

Requirement

1. All moving parts of the vibrating presser must function freely and without play.
2. The vibrating presser must not touch the presser foot.

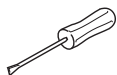
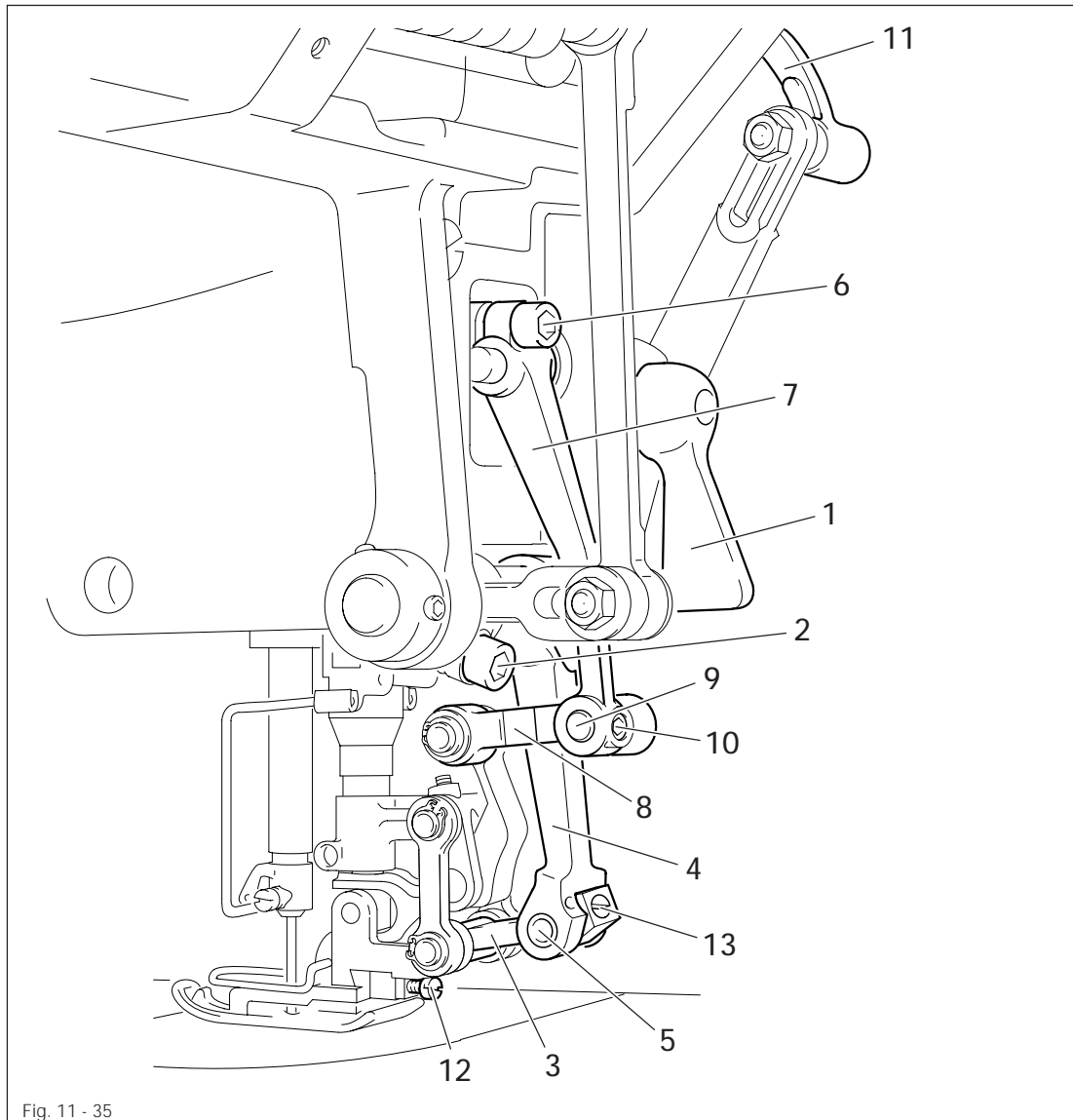

- Lower the presser foot using hand lever 1.
- Loosen screw 2.
- Swing connecting link 3 into the fork of lever 4 and insert bolt 5.
- Ensure that the machine runs freely. Adjust lever 4 if necessary.
- Tighten screw 13.
- Set the stitch length at "0".
- Align the vibrating presser foot in the middle of the presser foot cutout as viewed in the direction of sewing and tighten screw 2.
- Loosen screw 6.
- Align the hole in lever 7 with the elongated hole of lever 8 without lateral play. If necessary move/adjust lever 7.

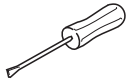

- Insert pin 9 with its largest eccentricity facing downwards into the elongated hole of lever 8 and into the hole in lever 7.
- Tighten screw 10.
- Bring lever 11 to its outer point of reversal.
- Press lever 7 in the direction of feed until you feel it stop and then tighten screw 6.
- Loosen screw 12 and align the vibrating presser foot in accordance with requirement 2.
- Tighten screw 12.

11.05.33 Vibrating presser stroke

Requirement

With the stitch length set at "0", the presser foot resting on the needle plate and the vibrating presser foot at its upper point of reversal, there must be one of the following clearances between the needle plate and the vibrating presser foot, depending on the model of the vibrating presser foot.

Subclass -706/81: 1.3 mm on pulling-type vibrating pressers.

2.0 mm on pushing-type vibrating pressers behind.

Subclass -706/83: 1.3 mm on pulling-type vibrating pressers.

3.2 mm on pushing-type vibrating pressers.

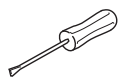
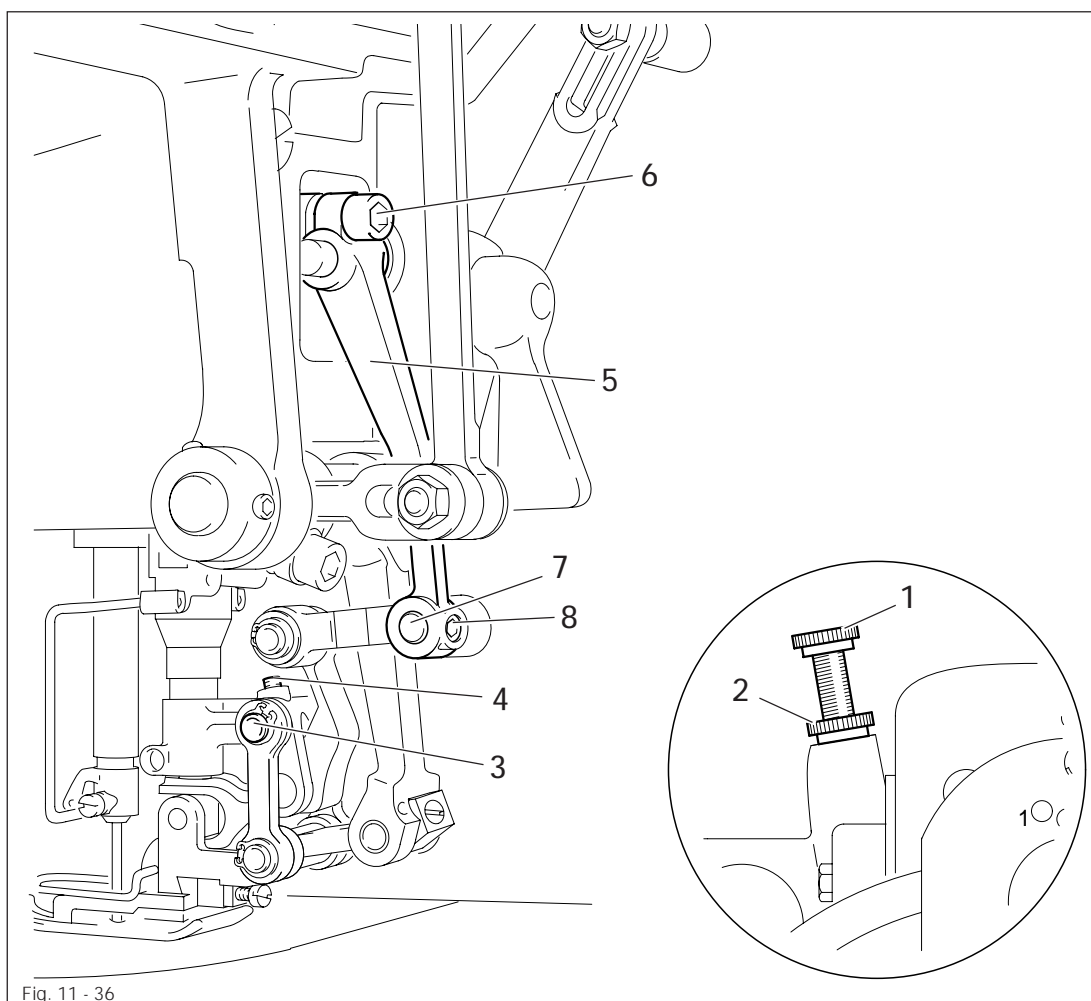

- Loosen nut 2 and increase the pressure on the presser foot a little with screw 1.
- Allow the presser foot to rest on the needle plate.
- Loosen screw 4, move the eccentricity of bolt 3 towards the needle bar and tighten screw 4.
- Turn the balance wheel until lever 5 is at its rear point of reversal.
- Loosen screw 6 and press lever 5 to the rear.
- Slide a gauge conforming with the **requirement** between the vibrating presser foot and the needle plate and tighten screw 6.
- Loosen screw 8 and turn eccentric pin 7 for the final adjustment.
- Tighten nut 2 and screw 8.

11.05.34 Vibrating presser lifting motion

Requirement

The vibrating presser must be touching the bottom feed dog when the rising bottom feed dog has reached the top edge of the needle plate with the stitch length set at "2" .

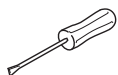
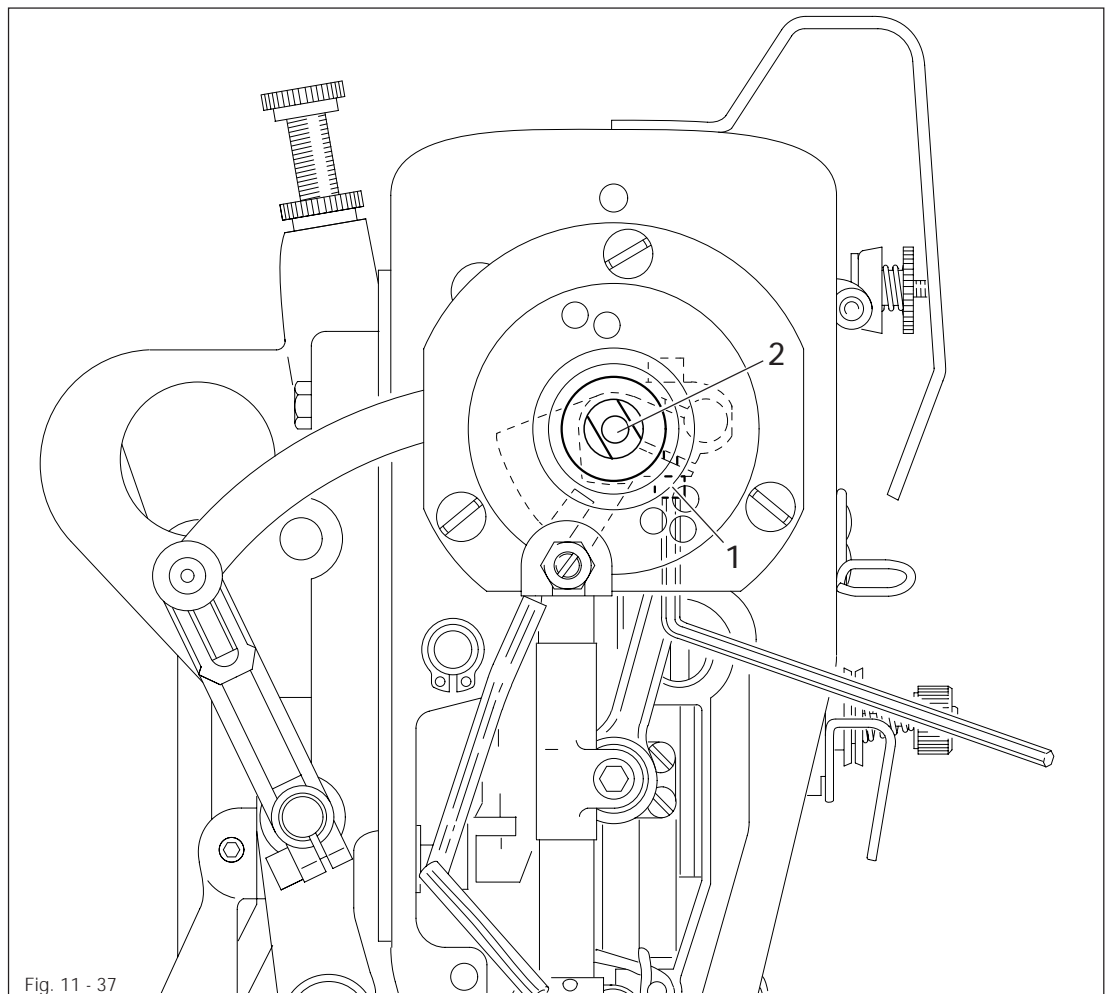

- Loosen screw 1 and turn eccentric bolt 2 in accordance with the requirement.
- Tighten screw 1.

11.05.35 Vibrating presser feeding motion

Requirement

At the maximum stitch length and with the needle bar at 1.0 past tdc (hole 4), the vibrating presser must not move when the reverse feed key is moved up and down.

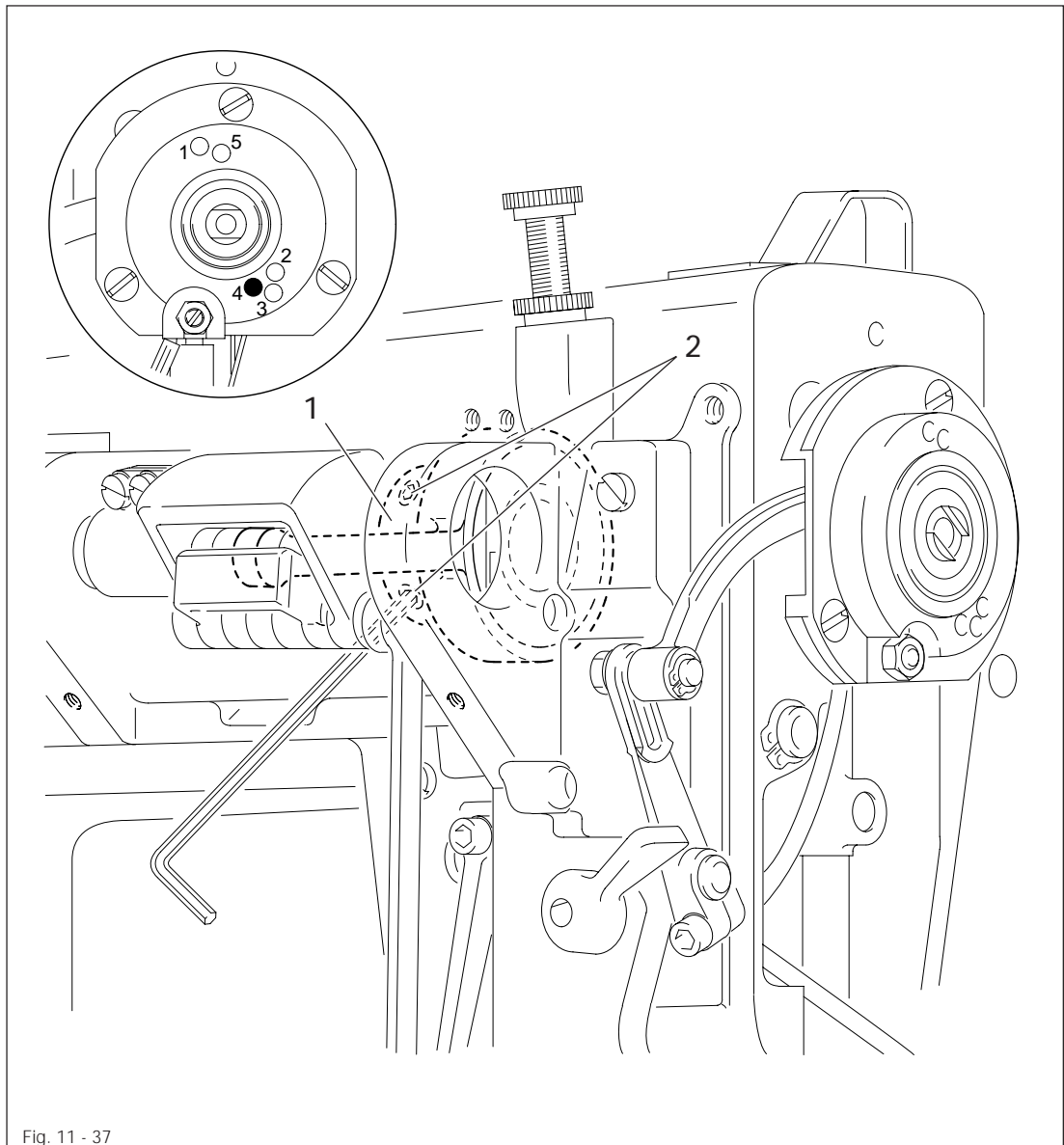
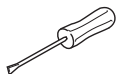

Fig. 11 - 37



- Raise the presser foot.
- Loosen screws 2 and turn feed eccentric 1 until the second screw in the direction of rotation as seen from the rear is visible.
- Turn the feed eccentric in accordance with the **requirement**.
- Tighten screw 2.

11.05.36 Feeding motion difference

Requirement

With both top feed adjustment wheels at "0" and the largest stitch length set, the feeding strokes of the vibrating presser and the bottom feed dog must be the same length.

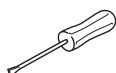
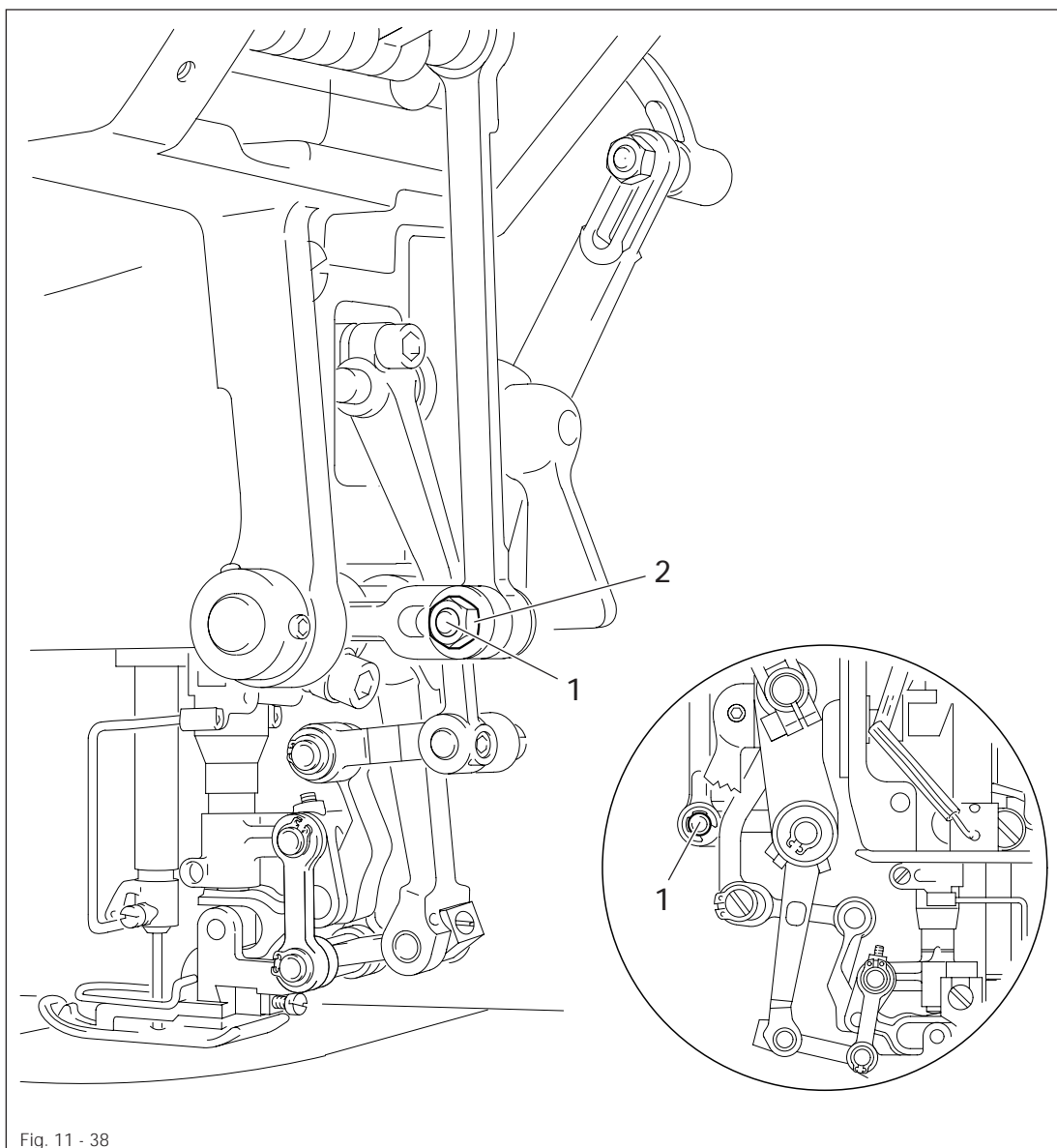

- Loosen nut 2 and move bolt 1 in the elongated hole in accordance with the requirement.
- Tighten nut 2.

11.05.37 Vibrating presser and presser foot pressure

Requirement

The material must be fed reliably even at top sewing speed. There must be no pressure marks on the material.

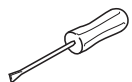
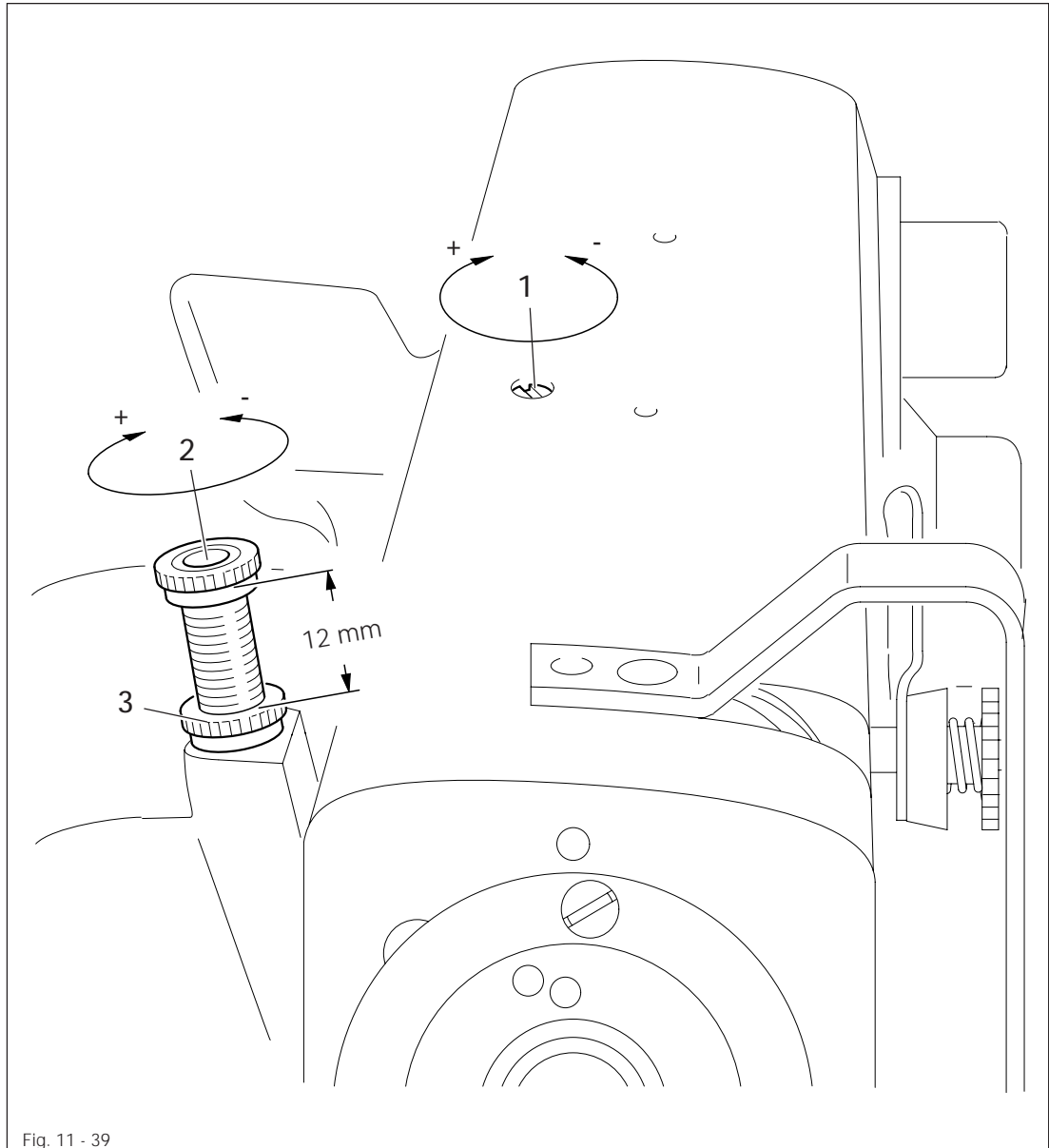

- The top edge of screw 1 must be approx. 13 mm underneath the top edge of the housing.
- Loosen nut 3.
- Turn screw 2 until there is a clearance of approx. 12 mm between its collar and the machine housing.



The pressure on the vibrating presser (screw 1) and the presser foot (screw 2) can be increased (+) or decreased (-) as required.

11.05.38 Thread diverter pin

Requirement

With the needle bar at bdc the top edge of the thread guide hole must be at the same height as the bottom edge of the thread diverter.

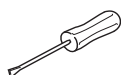
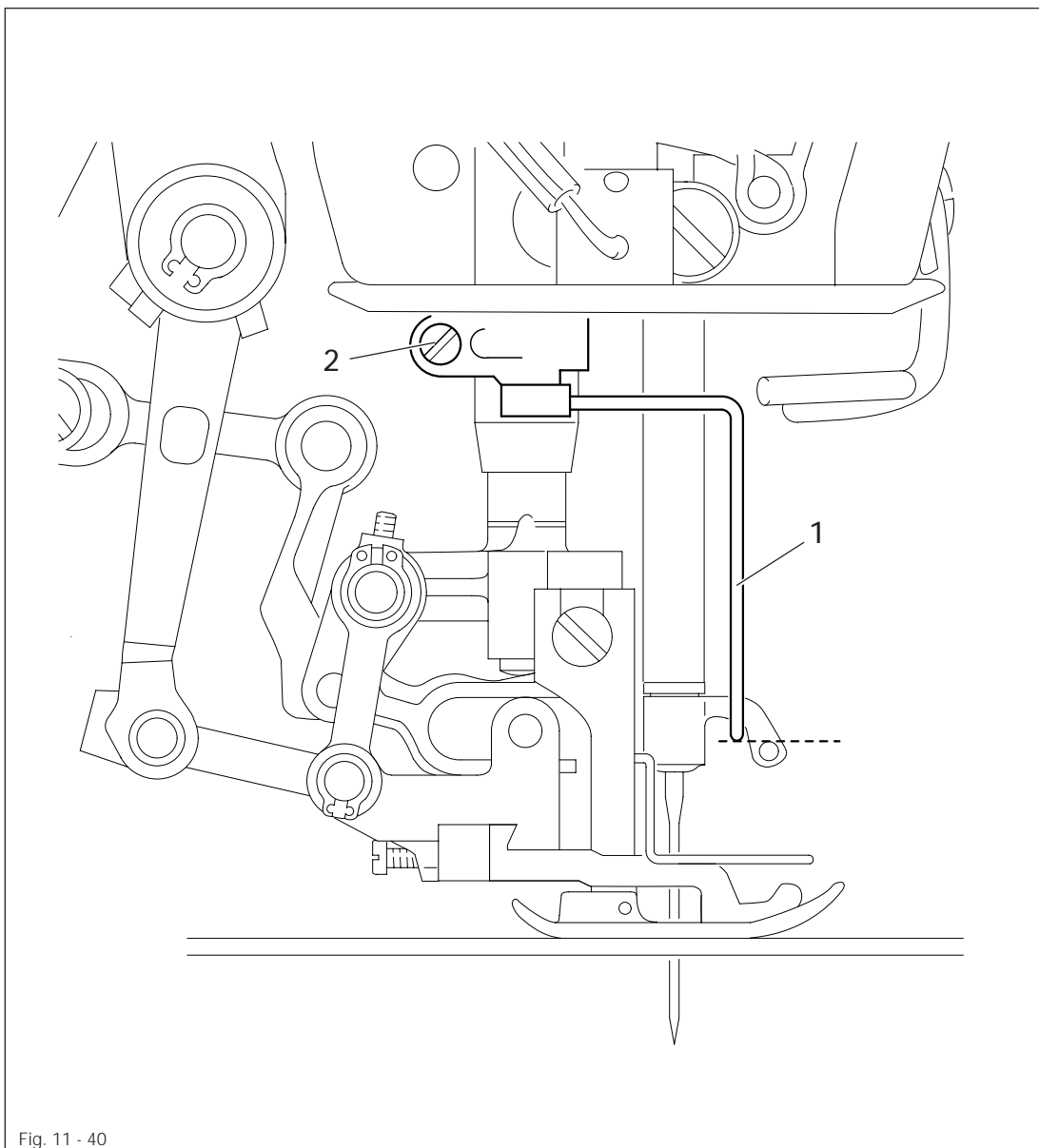

- Loosen screw 2.
- Move thread diverter 1 in accordance with the **requirement**, ensuring that it remains parallel to the base plate.
- Tighten screw 2.

Adjustment

11.05.39 Needle-thread tension release (machines without -900/..)

Requirement

With the hand lever raised the tension discs must be approx. 0.5 mm apart.

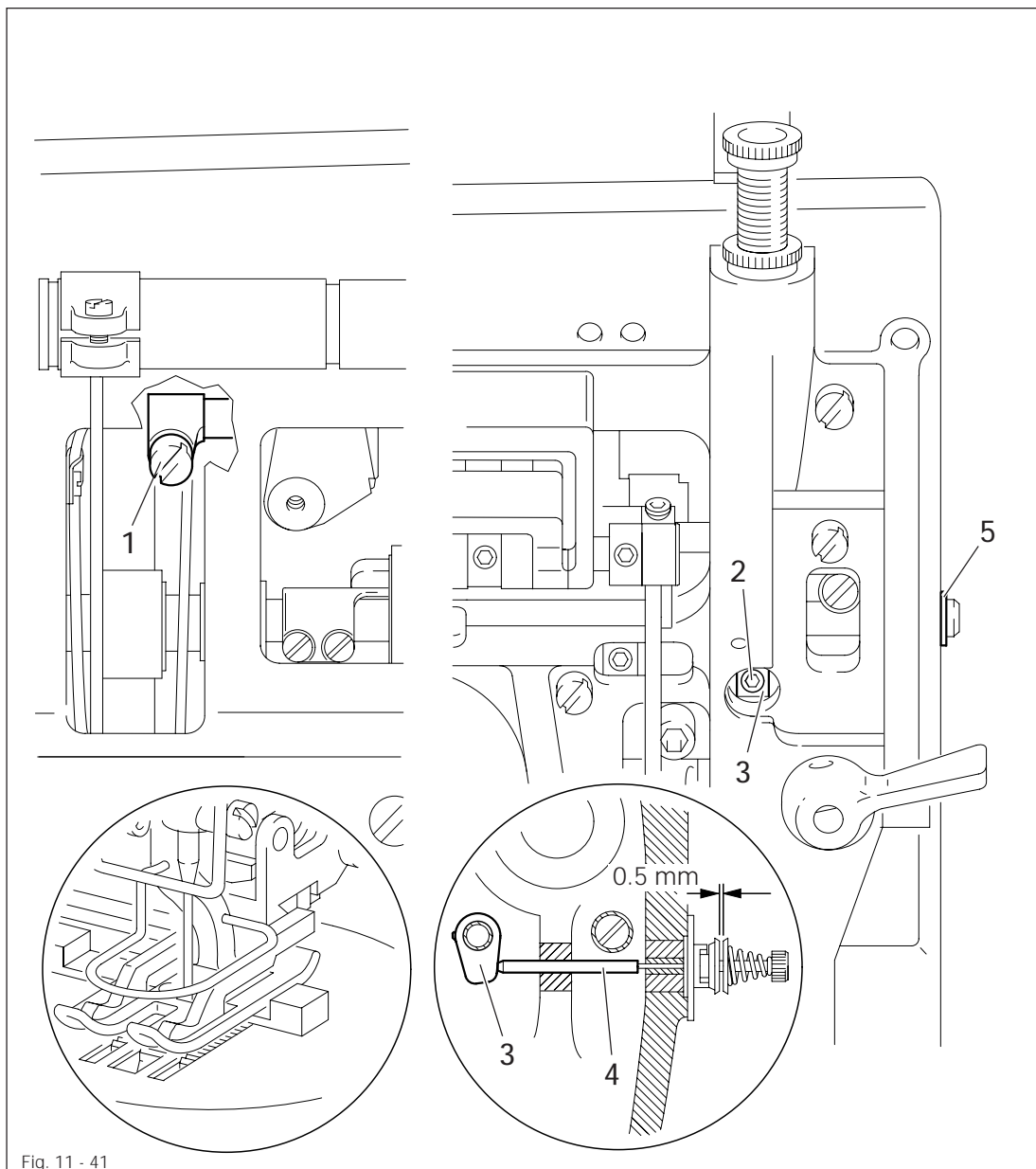
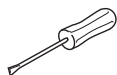

Fig. 11 - 41



- Loosen screw 1 and press the connecting rod down as far as it will go.
- Raise the presser foot.
- Adjust cam 3 according to the requirement.
- Tighten screw 2.

11.05.40 Limiting the knee lever stroke

Requirement

When the knee lever is pressed the hand lever must drop automatically and the presser foot must be just over 7 mm above the needle plate.

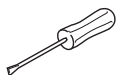
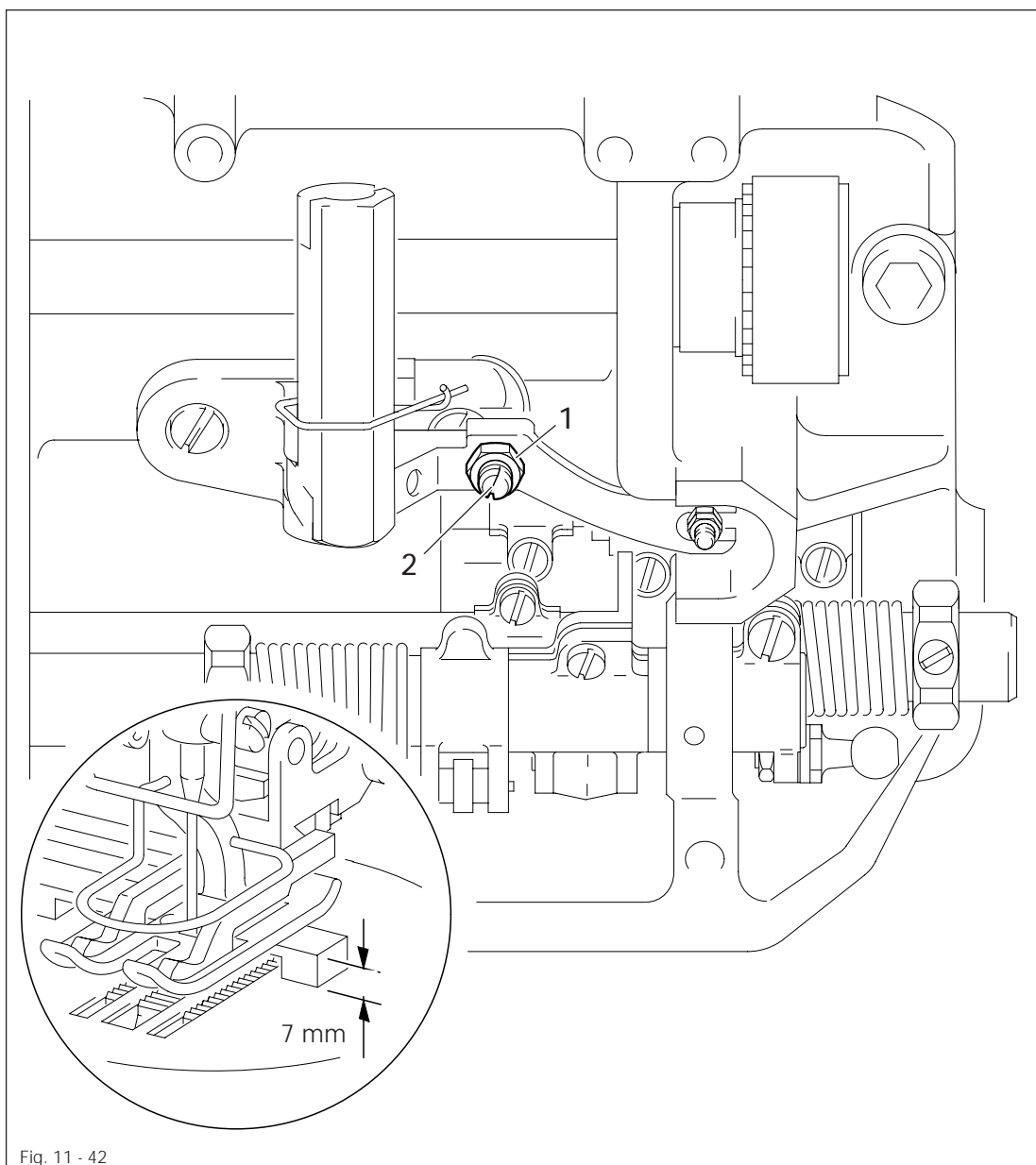

- Loosen nut 1.
- Tighten screw 2 according to the requirement.
- Tighten nut 1.

11.05.41 Knee lever play

Requirement

When lightly pressing the knee lever there should be a noticeable play between nut 1 and fork 3.

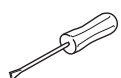
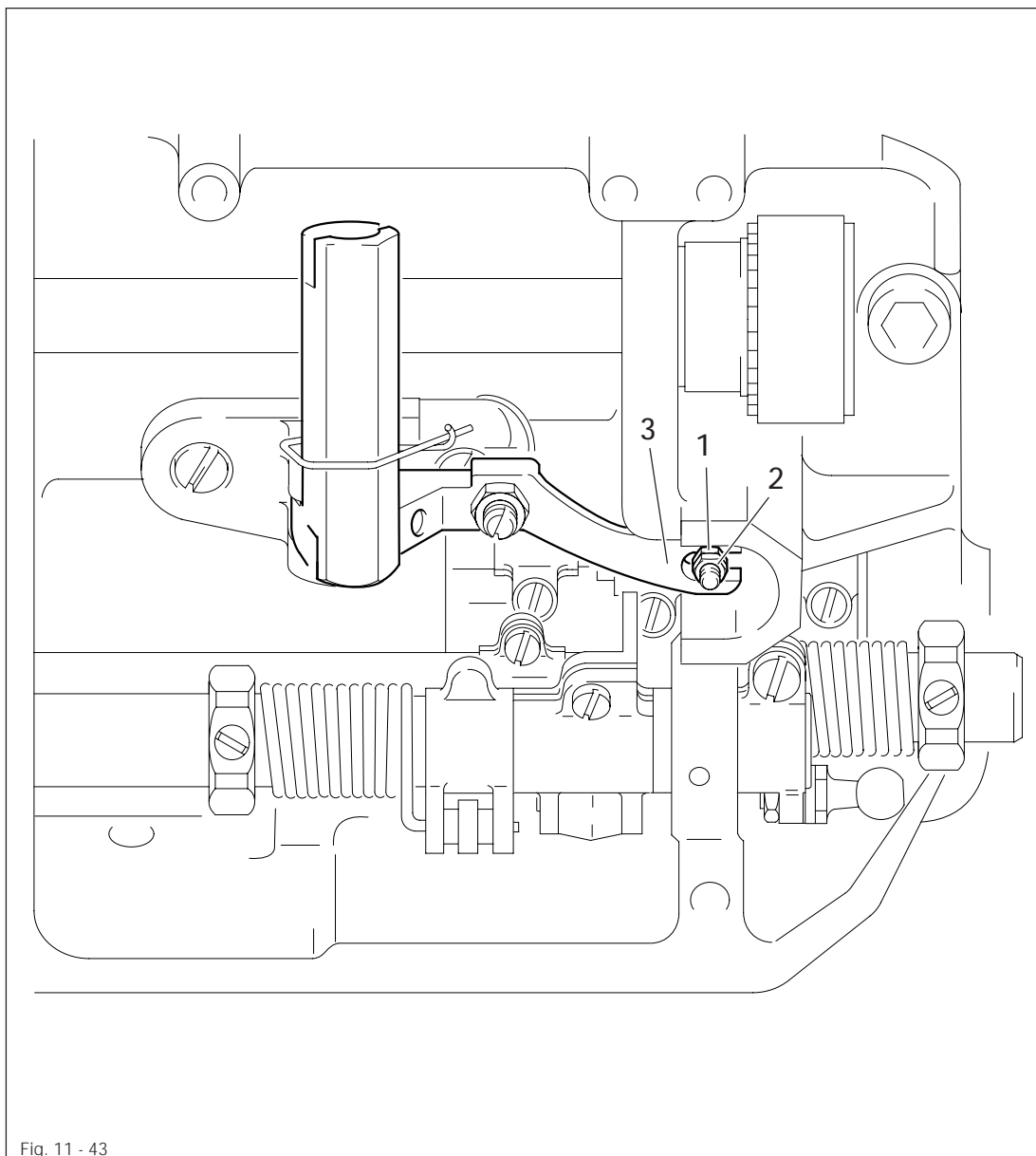

- Loosen nut 2.
- Turn nut 1 in accordance with the requirement and lock it with nut 2.

11.05.42 Bobbin winder

Requirement

1. With the bobbin winder engaged the bobbin winder spindle must be turned reliably, but friction wheel 3 must not touch drive wheel 1 when the bobbin winder is switched off.
2. The bobbin winder must disengage automatically when the thread is approx. 1 mm from the edge of the bobbin.

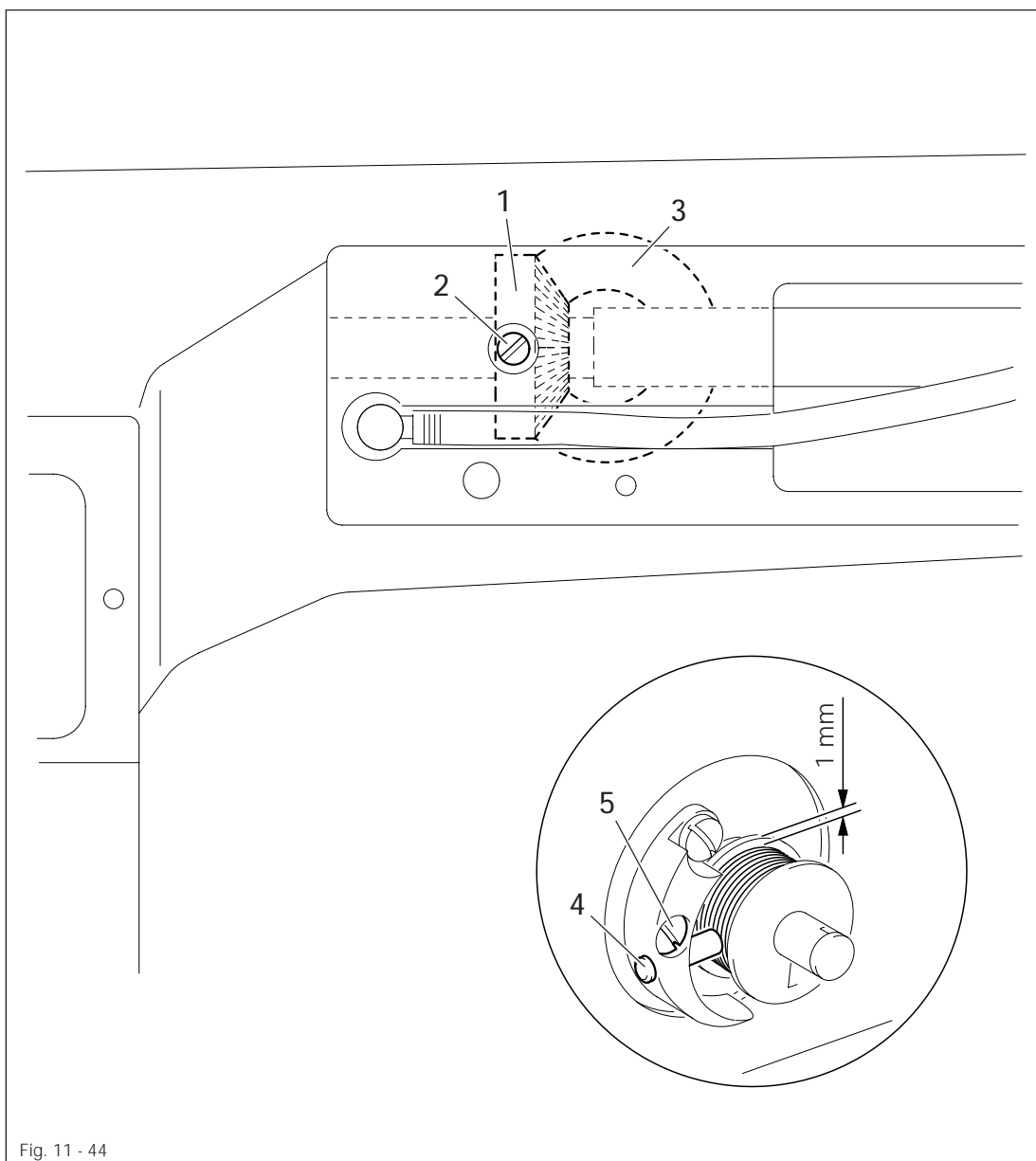

Fig. 11 - 44



- Loosen screw 2.
- Position drive wheel 1 in accordance with **requirement 1** and tighten screw 2.
- Place a bobbin onto the bobbin winder, thread the bobbin and engage the bobbin winder
- Loosen screw 5.
- Position pin 4 according to **requirement 2** and tighten screw 5.
- Move regulating pin 4 in accordance with requirement 2 and tighten screw 5.

11.06 Adjusting the thread trimmer -900/51

11.06.01 Pre-adjusting the control cam

Requirement

With the needle bar at tdc (hole 2):

1. the beginning of the highest point of the lobe of control cam 1 must be underneath the point of pawl 2,
2. the right hand side of the lobe must be flush with pawl 2.

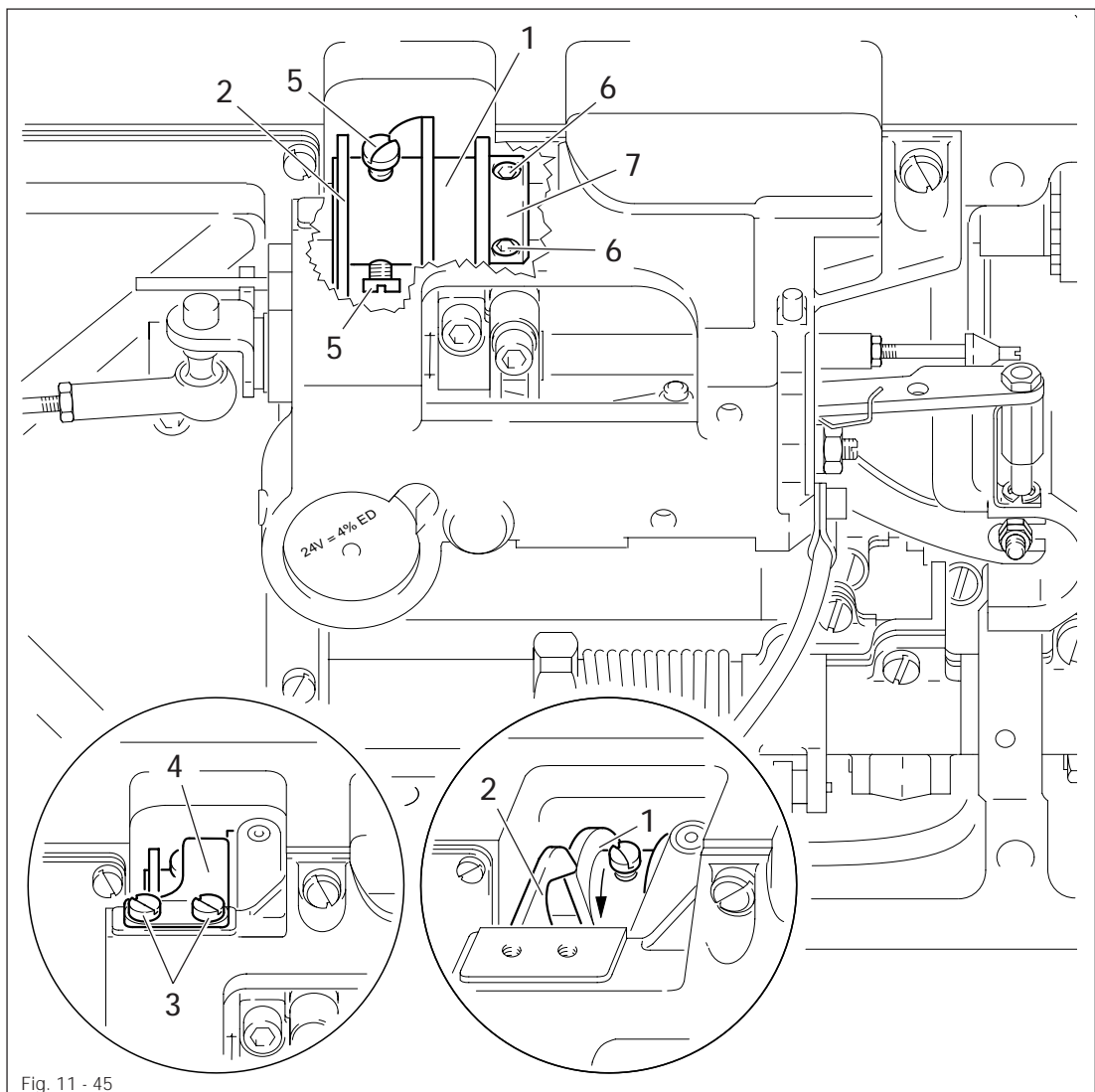
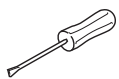

Fig. 11 - 45



- Unscrew screw 3 and remove retaining spring 4 together with the cover washer.
- Loosen screws 5 and 6.
- Turn control cam 1 in accordance with requirement 1 and position it in accordance with requirement 2.
- Tighten screws 5.
- Push retaining collar 7 onto control cam 1 and tighten screws 6.



Retaining spring 4 stays removed for the following adjustments.

11.06.02 Roller lever

Requirement

With the needle bar 2.0 past bdc (hole 1):

1. the roller of roller lever 1 must fall lightly into control cam 2 when roller lever 1 is lightly tapped

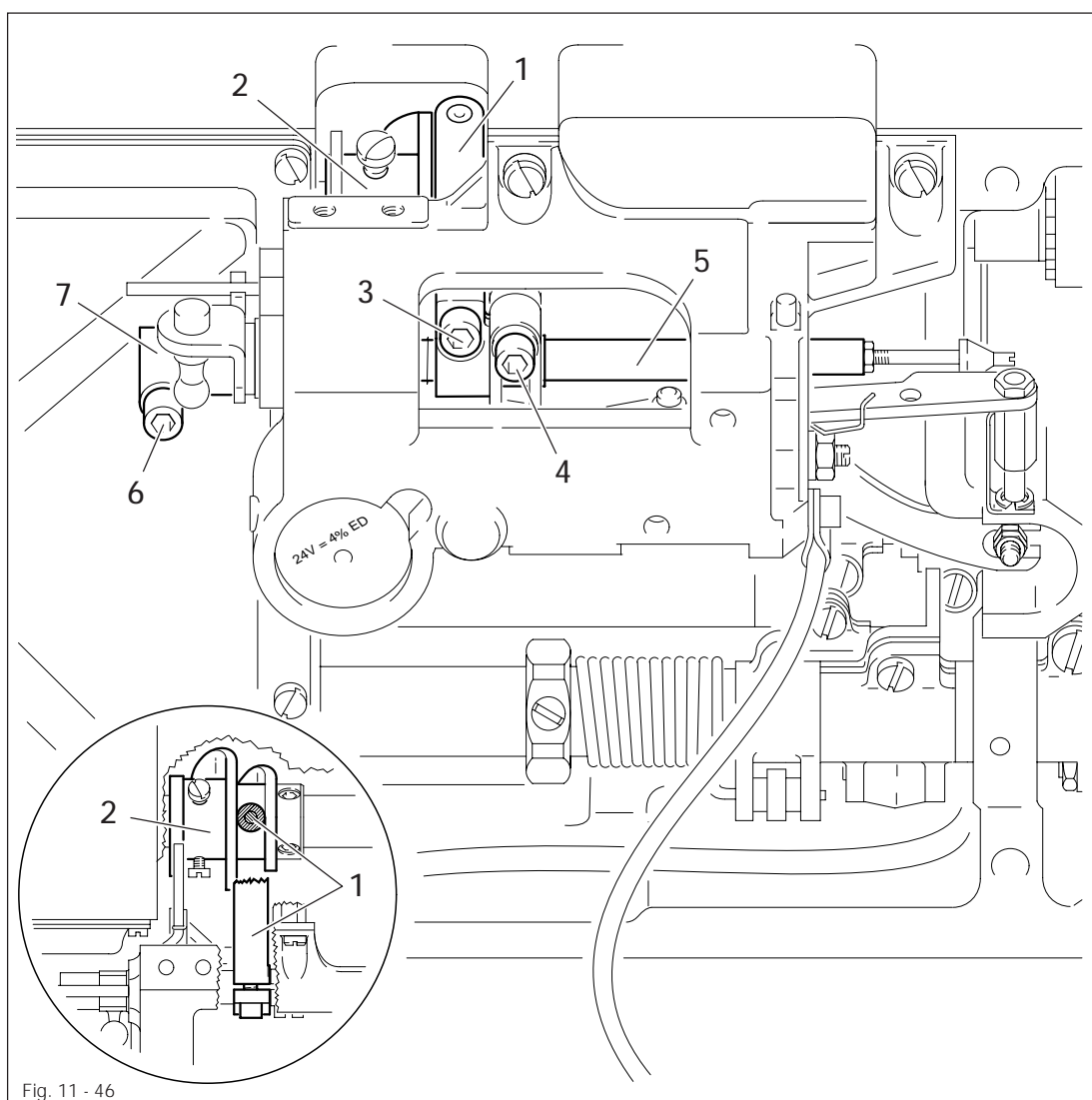
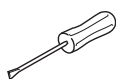

Fig. 11 - 46



- Loosen screws 3 and 4.
- Put pressure on rock shaft 5 to the right.
- Move roller lever 1 in accordance with the **requirement**.
- Tighten screw 3.
- Loosen screw 6 and position the flat of retaining collar 7 parallel to the bedplate.
- Tighten screw 6.



Screw 4 remains unscrewed for further adjustments.

Requirement

With the thread trimmer in resting position there must be a clearance of **0.3 mm** between pawl 1 and the largest eccentricity of the lobe on control cam 2.

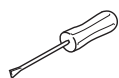
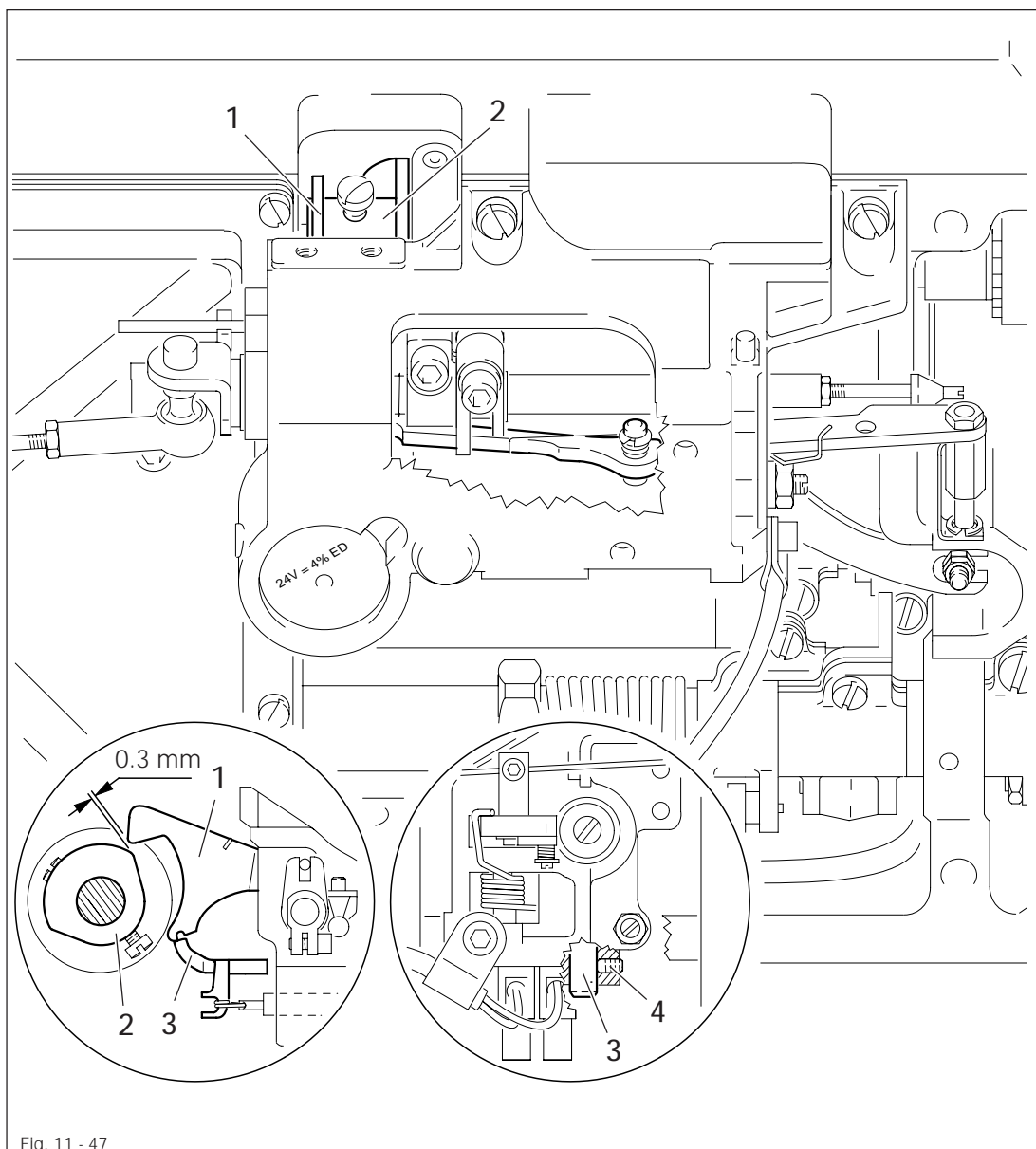

- Position the largest eccentricity of the lobe on control cam 2 underneath pawl 1.
- Loosen screw 4.
- Position pin 3 in accordance with the requirement.
- Tighten screw 4.

11.06.04 Engaging solenoid

Requirement

With the needle bar 2.0 past bdc (hole 1) there must be a clearance of 0.2 to 0.3 mm between engaging lever 2 and pawl 1 when the engaging solenoid is active.

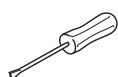
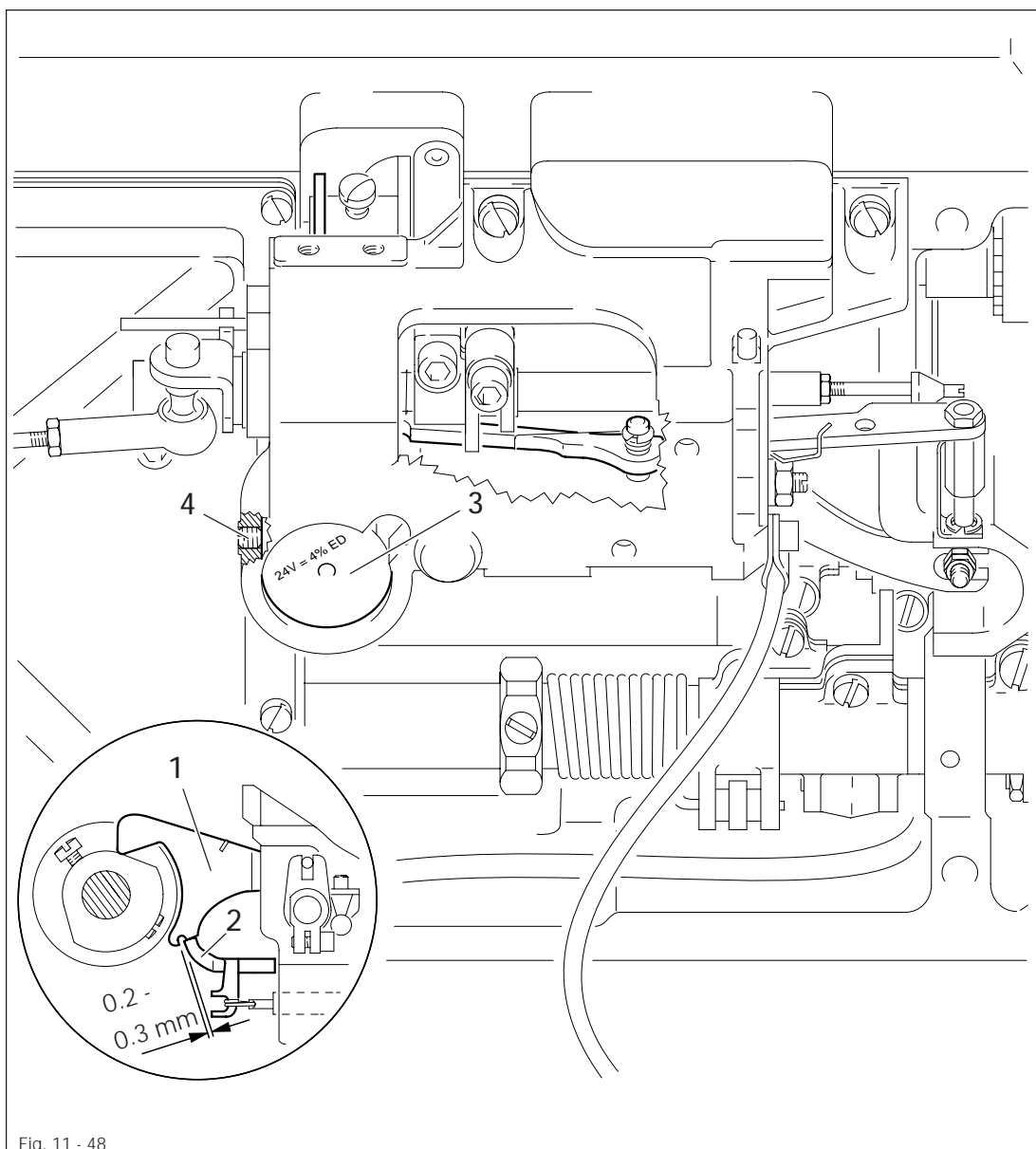

- Position the needle bar 2.0 after bdc (hole 1).
- Activate engaging lever 2 manually until pawl 1 drops into place.
- Loosen screw 4.
- Press the solenoid plunger as far as possible into the solenoid housing 3 and move solenoid housing 3 and the cutout arm in accordance with the requirement.
- Tighten screw 4.

Requirement

With the needle bar 2.0 after bdc (hole 1) there must be a clearance of **0.2 mm** between the roller of roller lever 1 and the base of control cam 2 with the engaging lever active.

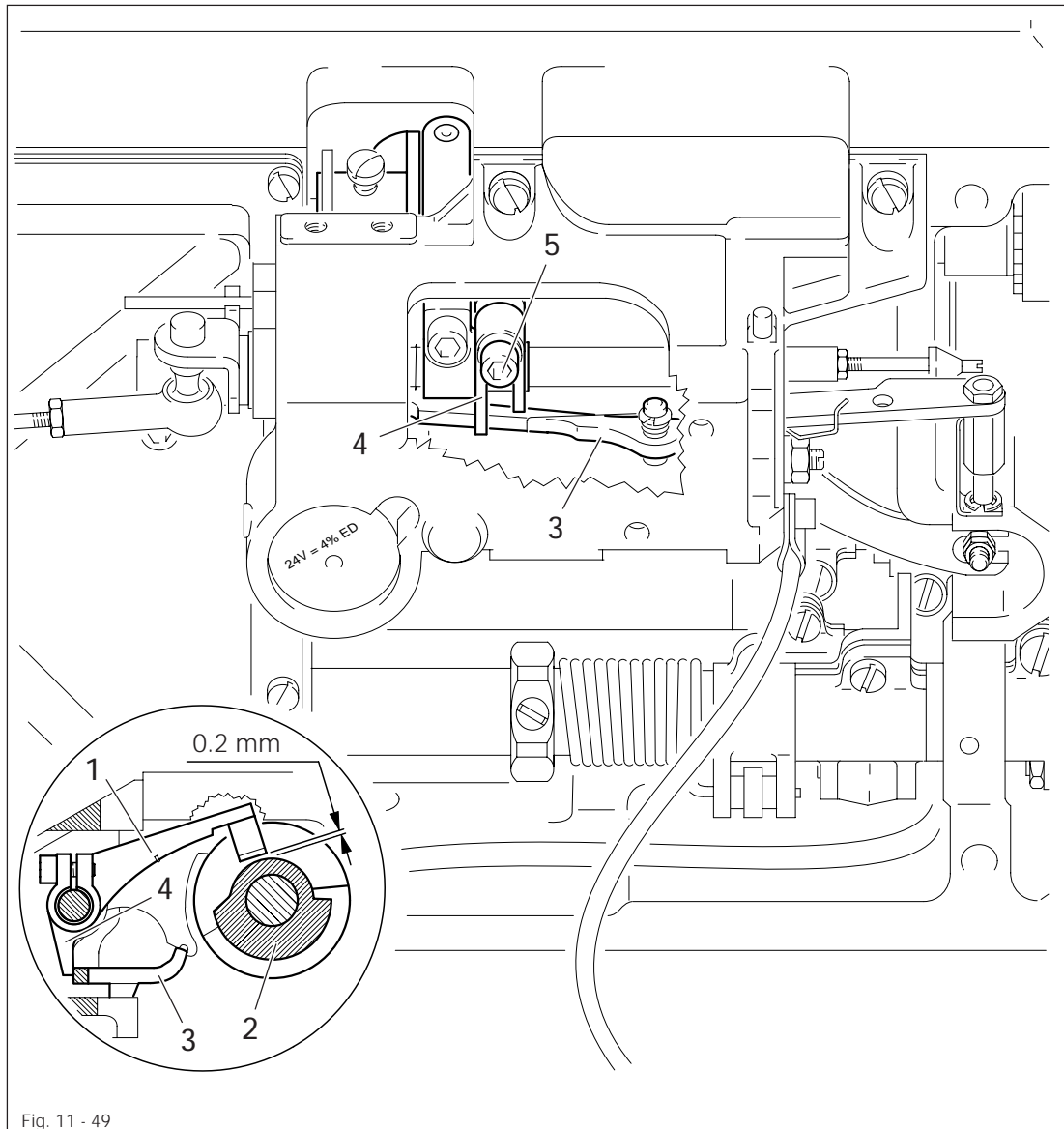
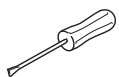

Fig. 11 - 49



- Position the needle bar 2.0 after bdc (hole 1).
- Activate engaging lever 3 manually.
- Press roller lever 1 down to the base of control cam 2.
- Position lever 4 on engaging lever 3 in such a way that there is a clearance of 0.2 mm between roller lever 1 and the base of control cam 2. Lever 4 must be touching roller lever 1 from the side.
- Tighten screw 5.

11.06.06 Engaging lever

Requirement

With the needle bar at tdc and the thread trimmer in resting position, there must be a clearance of 0.3 to 0.5 mm between the roller of roller lever 1 and the external diameter of control cam 2.

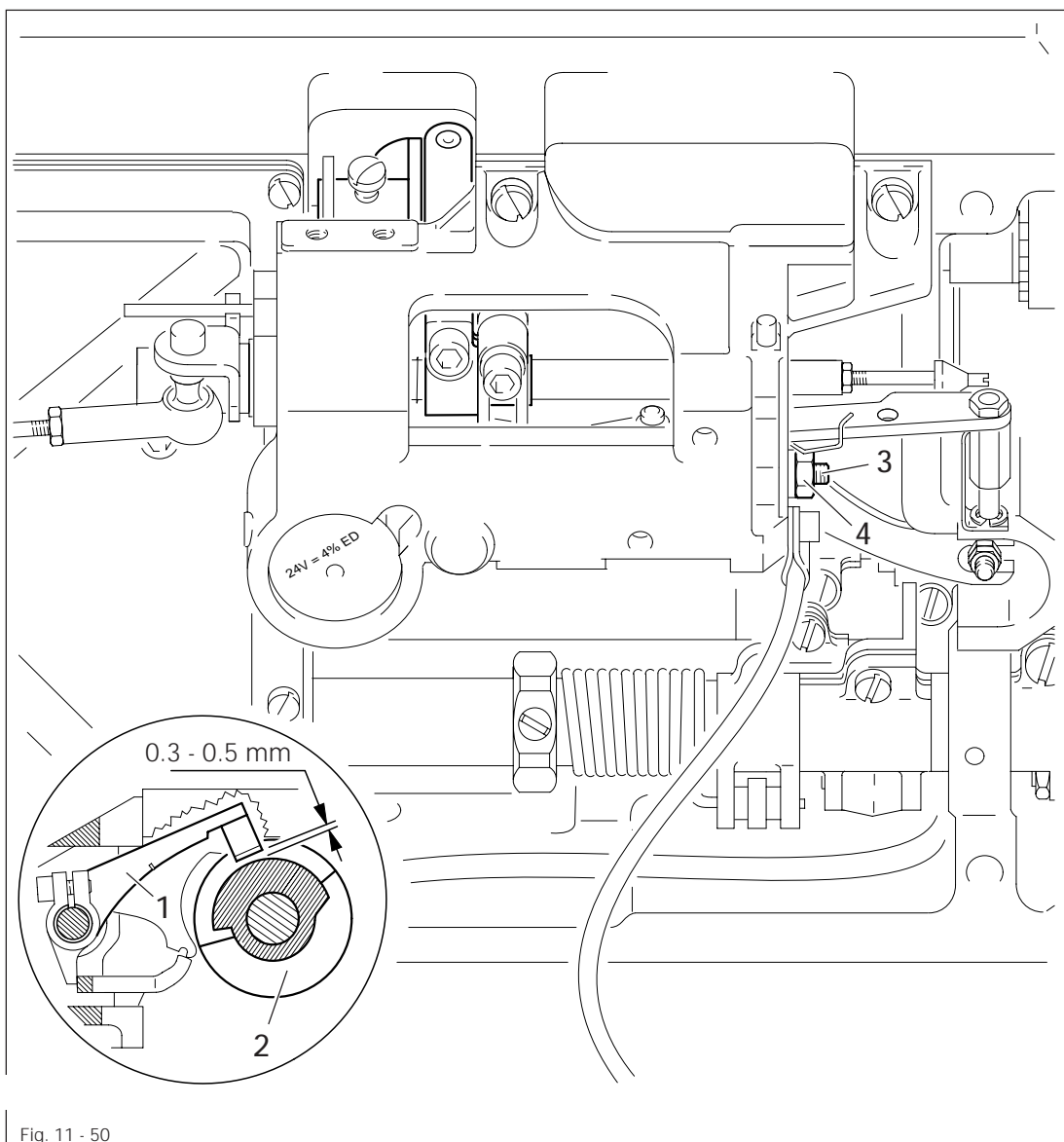
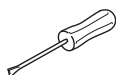

Fig. 11 - 50



- Loosen nut 4.
- Turn screw 3 in accordance with the requirement.
- Tighten nut 4.

11.06.07 Thread catcher position and cutting test

Requirement

With the thread trimmer in resting position the edge of thread trimmer 1 must be flush with the edge of bracket 2.

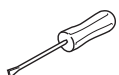
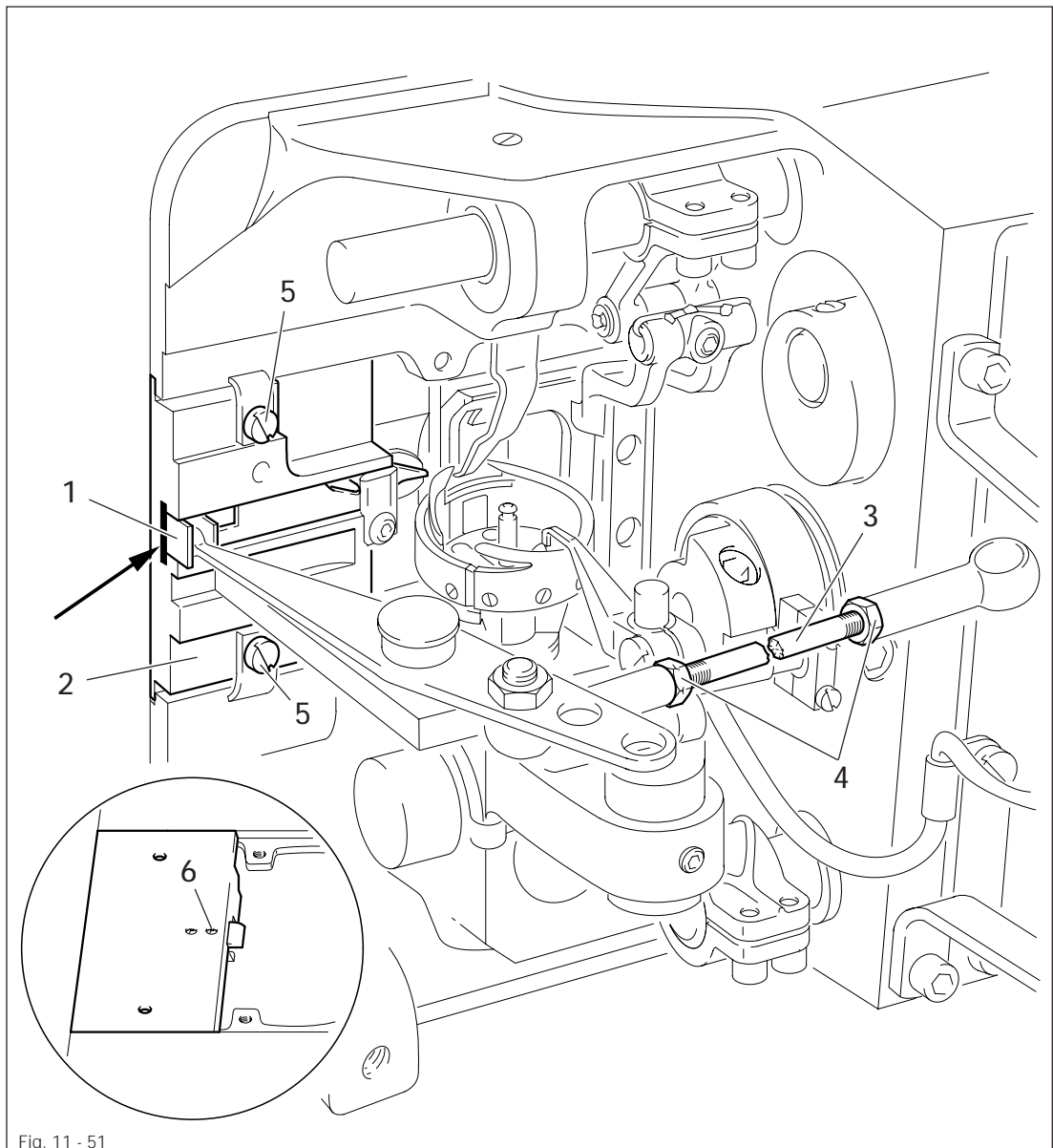

- Loosen nuts 4 (left and right-handed threads).
- Turn connecting rod 3 in accordance with the **requirement** and tighten nuts 4.
- For the cutting test disengage the connecting rod, loosen screws 5 and remove bracket 2.
- Adjust the cutting pressure by turning screw 6.
- Insert bracket 2 in such a way that its edge is flush with the edge of the bedplate.
- Tighten screws 5 and replace the connecting rod.

11.06.08 Control cam (final adjustment) and retaining spring

Requirement

1. with the end of thread guard 1 at the height of the right edge of bobbin case position finger 2, thread catcher 3 must begin its forwards movement.
2. With the thread trimmer in resting position there must be a clearance of 0.5 mm between retaining spring 7 and roller lever 8.

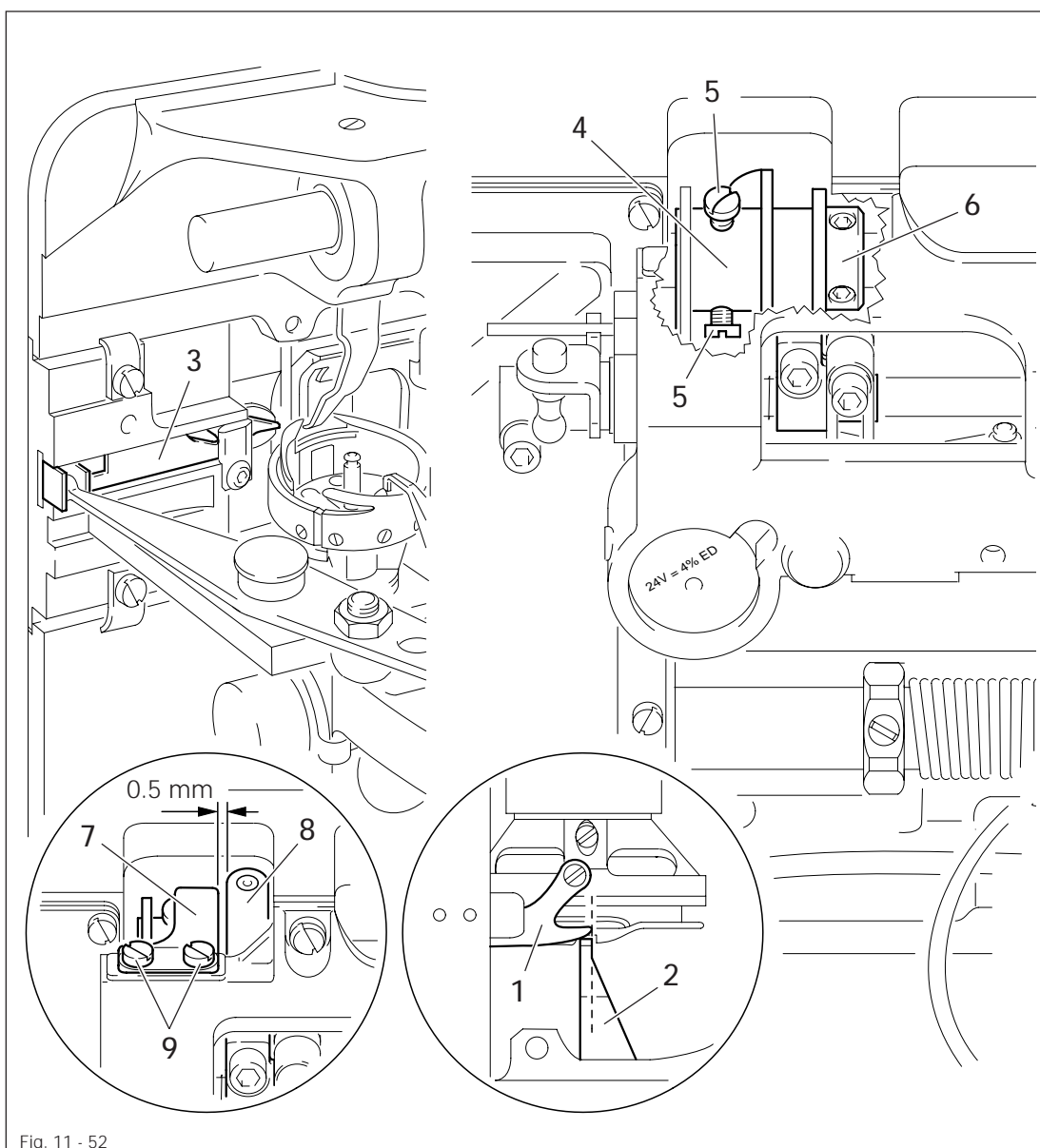
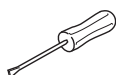

Fig. 11 - 52



- Position the needle bar at bdc.
- Activate the engaging lever.
- Loosen screws 5.
- Move control cam 4 in accordance with requirement 1 and position retaining collar 6 so that it is touching.
- Tighten screws 5.
- Fit retaining spring 7 together with the cover and tighten screws 9 lightly.
- Push retaining spring 7 upwards as far as possible and align it in accordance with requirement 2.
- Tighten screws 9.

Requirement

1. With hand lever 4 raised, the clearance between the tension disks must be 0.5 mm.
2. With the rock shaft 6 in its neutral position there must be a clearance of 0.5 mm between trip 8 and release cone 9.
3. With trip 8 at the highest point of release cone 9, the tension disks must be at least 0,5 mm apart.
4. With the needle trimmer in resting position and the presser foot on the needle plate the tension must be fully effective.

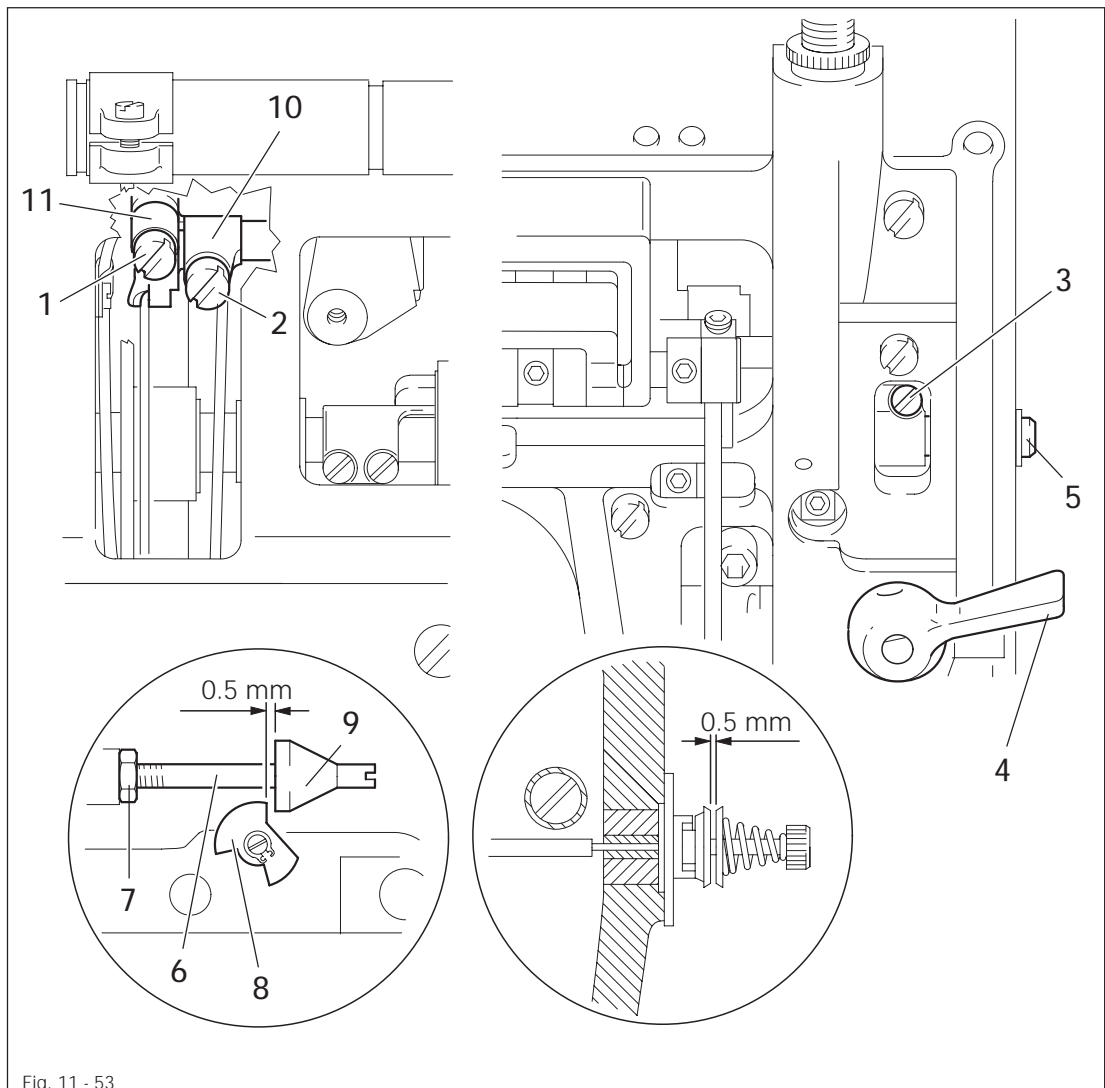
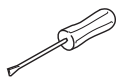

Fig. 11 - 53



- Loosen screws 1, 2 and 3.
- Lift hand lever 4.
- Adjust the clearance between the tension disks in accordance with requirement 1 by turning hollow shaft 5. Clamp a screwdriver in hollow shaft 5 to turn it.
- Tighten screw 3.
- Bring the rock shaft 6 to its starting position.

- Loosen nut 7.
- Adjust the clearance between trip 8 and release cone 9 in accordance with requirement 2.
- Tighten nut 7.
- Position the feed dog underneath the needle plate and bring the presser foot to rest on the needle plate.
- Press clamp piece 10 upwards.
- Tighten screw 2 taking care to ensure that hollow shaft 5 does not have any end play.
- Engage the thread trimmer manually. The presser foot must be lowered.
- Turn the balance wheel until trip 8 is at the highest point of release cone 9.
- Adjust the clearance between the tension discs in accordance with requirement 4 by turning the tension release shaft (accessible through hollow shaft 5 using a screwdriver).
- Press crank 11 upwards and tighten screw 1.
- Lightly grease release cone 9.
- Carry out a check according to the requirement.



Fine adjustment of the clearance between the tension disks can be made on eccentric pin 12 after loosening nut 13.

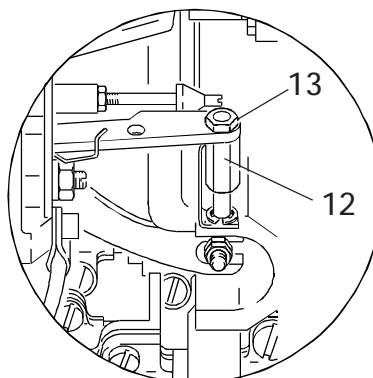

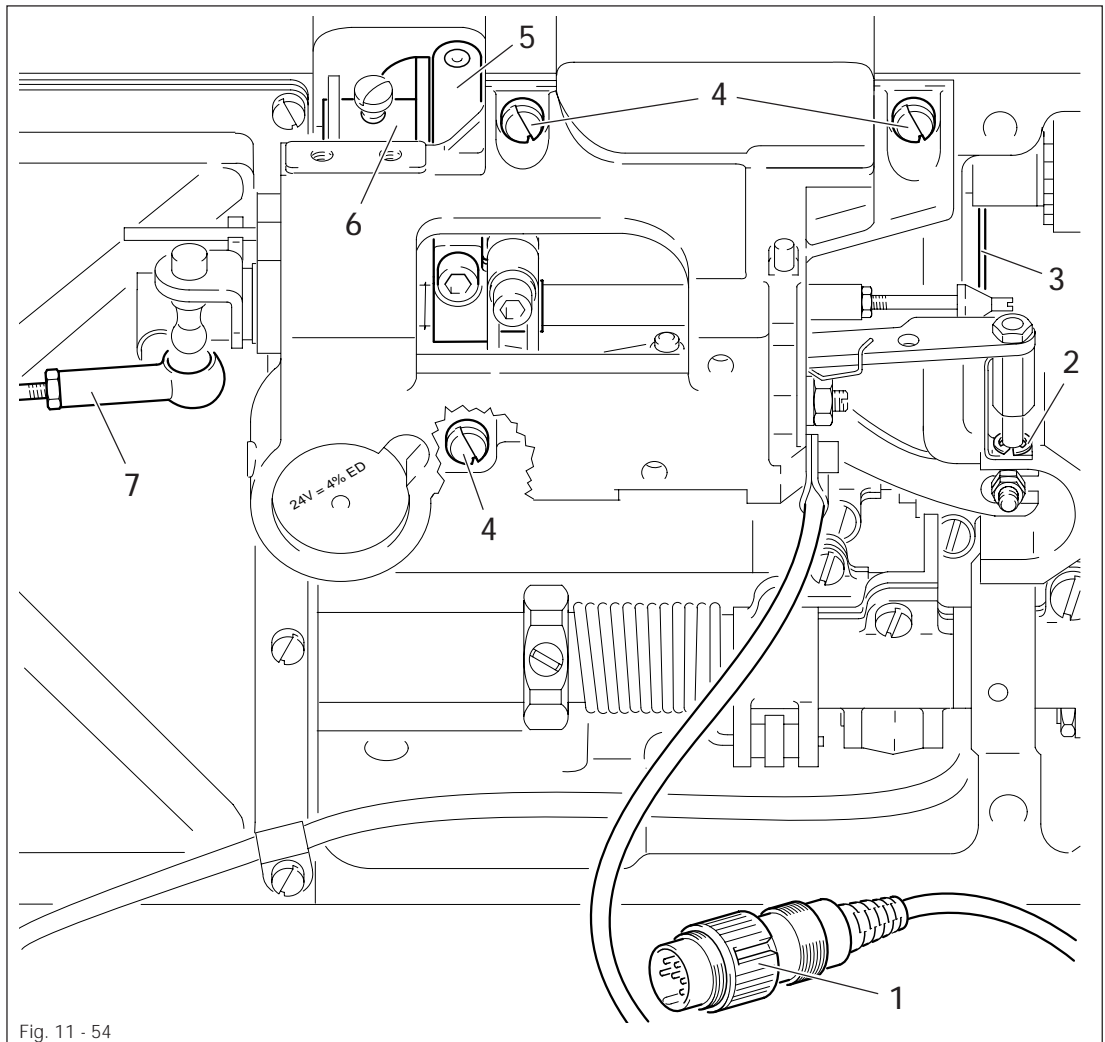
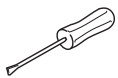

Fig. 11 - 54



- To remove the control unit, pull plug 1 out of the socket of the motor control plate or the control box.
- Remove circlip 2 and disconnect connecting rod 3.
- Disconnect the ball joints of connecting rod 7 from the studs on the cutting and control unit and remove the complete control unit.
- To refit the control unit, bring the needle bar to the needle rise position.
- Fit connecting rod 3.
- Replace the control unit and lightly tighten screws 4.
- Attach circlip 2.
- Bring needle bar to bdc.
- Activate the engaging lever manually so that roller lever 5 falls into control cam 6.
- Align the control unit in such a way that the roller of roller lever 5 is positioned in the middle of the cutout in control cam 6.
- Tighten retaining screws 4.
- Fit connecting rod 7 and carry out a manual function-test.
- If the engaging lever is not released, realign the control unit.

11.06.11 Synchronizer

Requirement

1. When sewing is stopped, the machine must position approx. 4 - 5 mm past the bdc of the needle bar.
2. After trimming the thread the machine must position at the tdc of the take up lever.

- For adjustment see the instruction manual of the motor manufacturer.

PFAFF

G.M. PFAFF
Aktiengesellschaft

Postfach 3020
D-67653 Kaiserslautern

Königstr. 154
D-67655 Kaiserslautern

Telefon: (0631) 200-0
Telefax: (0631) 172 02
Telex: 45753 PFAFF D

Gedruckt in der BRD
Printed in Germany
Imprimé en R.F.A.
Impreso en la R.F.A.
Stampato in R.F.G.
отпечатано ФРГ