

**PFAFF**<sup>®</sup>

**-900**

for Pfaff 440-0  
series machines

# Service Manual

---

Pfaff, D 6750 Kaiserslautern, Postfach 3020/3040, Telex: 045753

## **Instructions for adjusting subcl. -900 thread trimmers on Pfaff 440-0 series machines**

Note:

The following instructions for adjusting subcl. -900 thread trimmers apply to both single- and two-needle machines of the Pfaff 440-0 series. The illustrations show the two-needle version, but the text applies to the single-needle version. Additional adjustments that apply to the two-needle version are marked as such in the corresponding sections.

**The following tools, gauges and other items are required for adjusting subcl. -900 thread trimmers:**

- 1 set of screwdrivers with blades from 2 to 10 mm wide
- 1 set of allen keys from 1.5 to 6.0 mm
- 1 set of open-ended spanners from 7 to 14 mm (across flats)
- 1 metal rule
- 1 circuit tester
- Thread and material for testing purposes

# 1 Tension release trip

Correct setting:

When the control cam is in the non-operative position, trip 3 is positioned opposite tension release trip 4, and the presser foot is lowered, there should be a clearance of abt. 0.2 mm at the narrowest point between the left side of trip 3 and tension release trip 4.

## 1.0.2

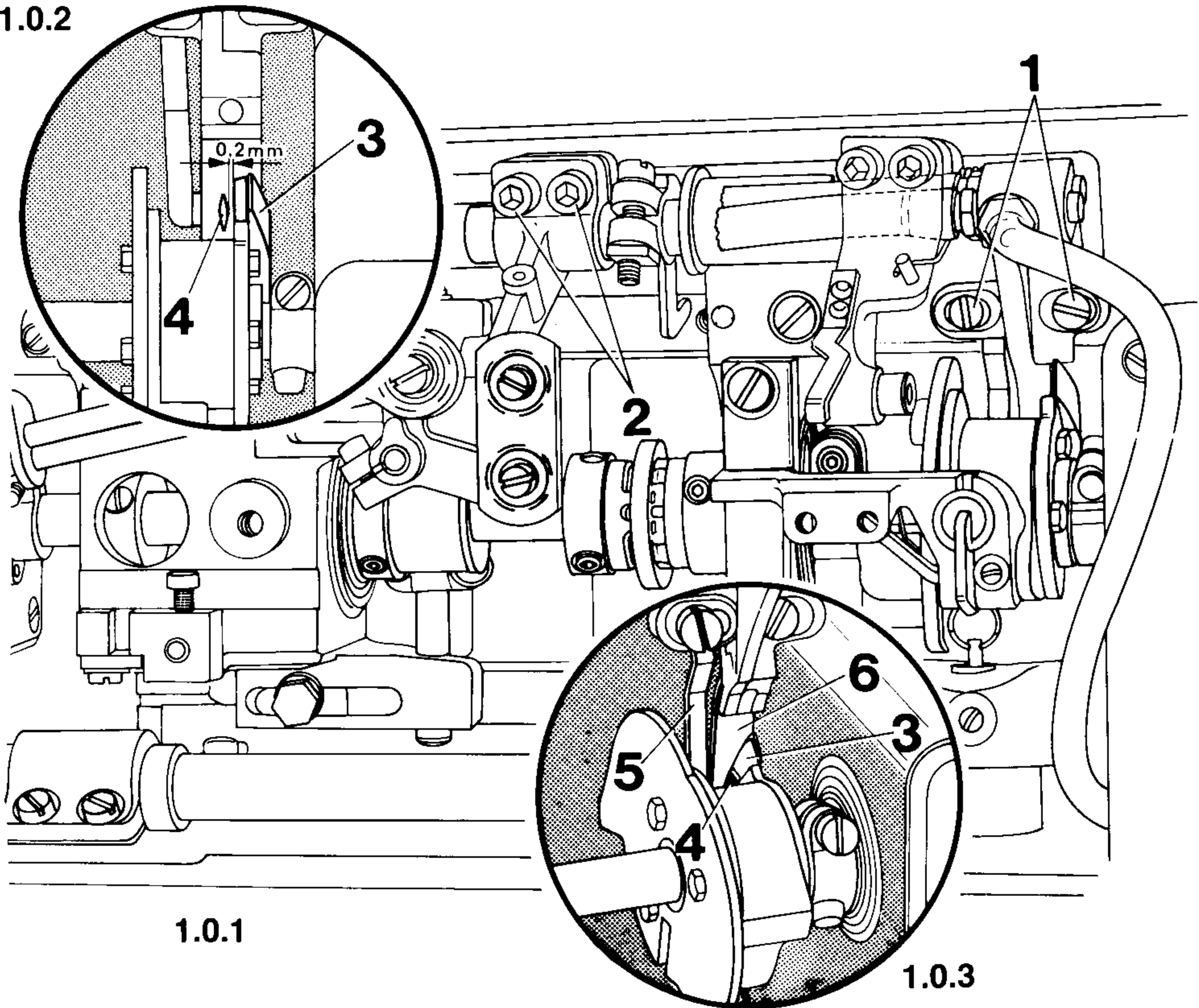

1.0.1

1.0.3

- 1.1 Unscrew the micro switch bracket.
- 1.2 Loosen screws 1 and for more extensive adjustments, also screws 2.
- 1.3 Turn the balance wheel until trip 3 is in line with tension release trip 4.
- 1.4 **Adjust the lateral position of stop finger 5 so that there is a clearance of abt. 0.2 mm at the narrowest point between the left side of trip 3 and tension release trip 4.**
- 1.5 In this position make sure that stop finger 5 is in contact with bracket 6 of the tension release trip. Then tighten both screws 1.
- 1.6 Check this adjustment (see "Correct setting").
- 1.7 If more extensive adjustments are to be made, screws 2 are to be left loose until the catcher actuating lever has been adjusted.

Correct setting:

When the tip of trip 1 is in line with control pin 2 and the engaging lever has been operated, there should be a clearance of 0.5 mm between the left inside of control cam 6 and control pin 2.

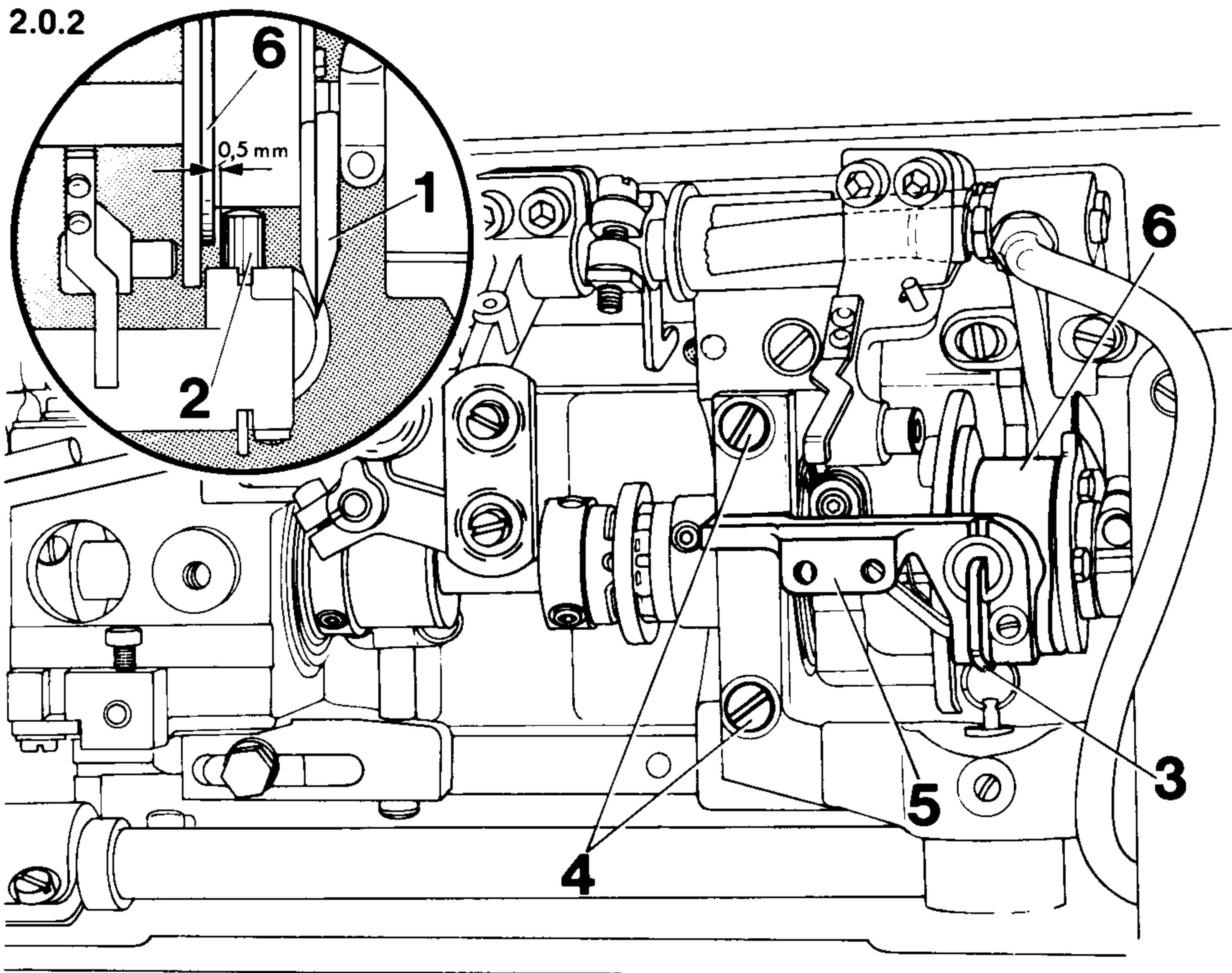

### 2.0.1

- 2.1 Turn the balance wheel until the tip of trip 1 is in line with control pin 2.
- 2.2 Operate engaging lever 3.
- 2.3 Loosen both screws 4.
- 2.4 **Adjust the position of solenoid bracket 5 so that there is a clearance of 0.5 mm between the left inside of control cam 6 and control pin 2.**
- 2.5 In this position, tighten screws 4.
- 2.6 Check this adjustment (see "Correct setting").

Correct setting:

When the trimming mechanism is at rest there should be a clearance of 0.1 mm between the highest point of cam track 1 and engaging lever pin 2.

## 3.0.2

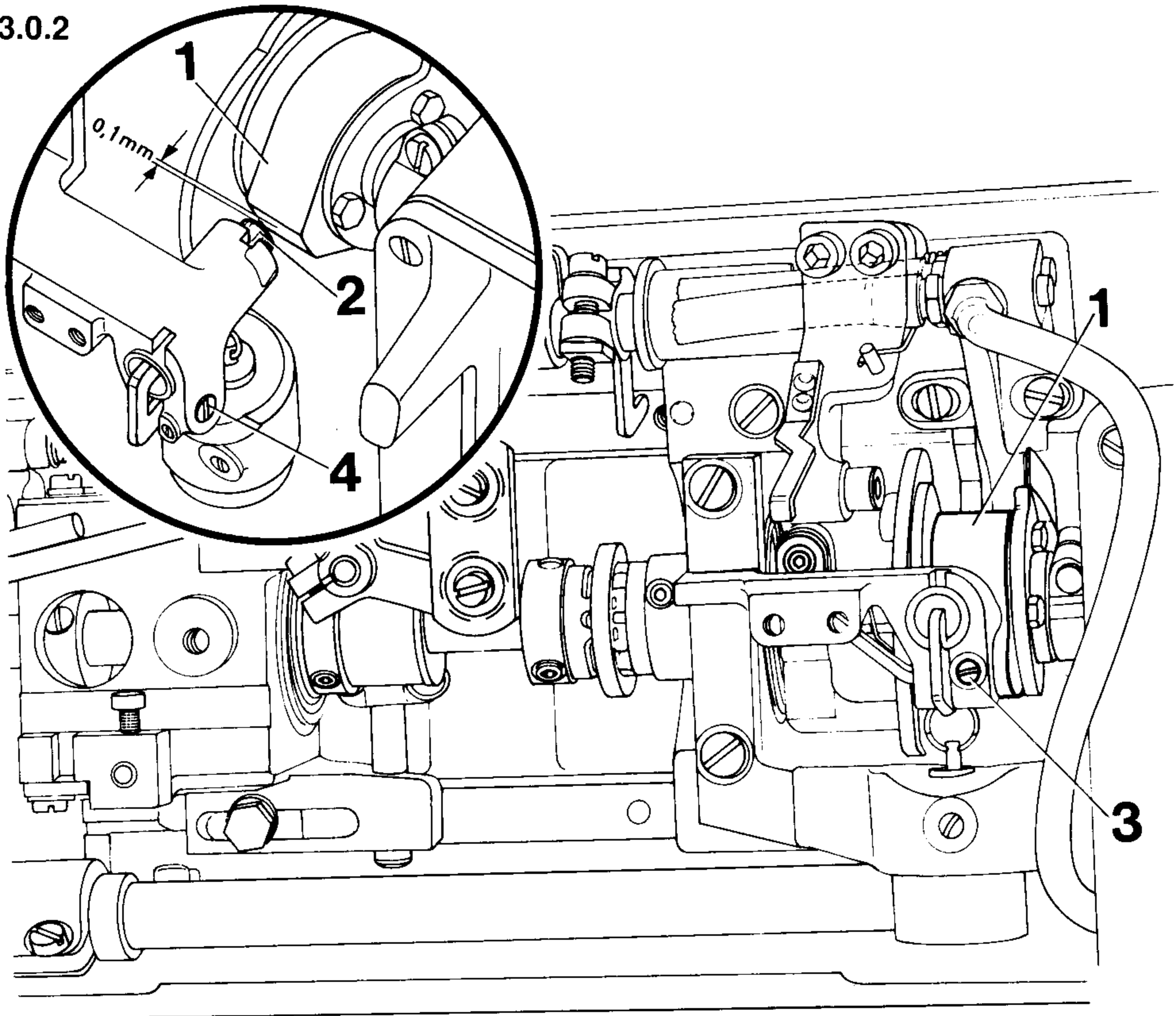

## 3.0.1

- 3.1 Make sure control cam 1 is in its non-operative position. Then turn the balance wheel until the highest point of cam track 1 is positioned opposite engaging lever pin 2.
- 3.2 Loosen screw 3.
- 3.3 **Turn eccentric stud 4 so that there is a clearance of 0.1 mm between cam track 1 and engaging lever pin 2.**
- 3.4 In this position, tighten screw 3.
- 3.5 Check this adjustment (see "Correct setting").

## 4 Control cam

### 4.1 Radial position

Correct setting:

When the take-up lever is at its highest point, the trimming action should be completed and the control cam should spring back to its starting position.

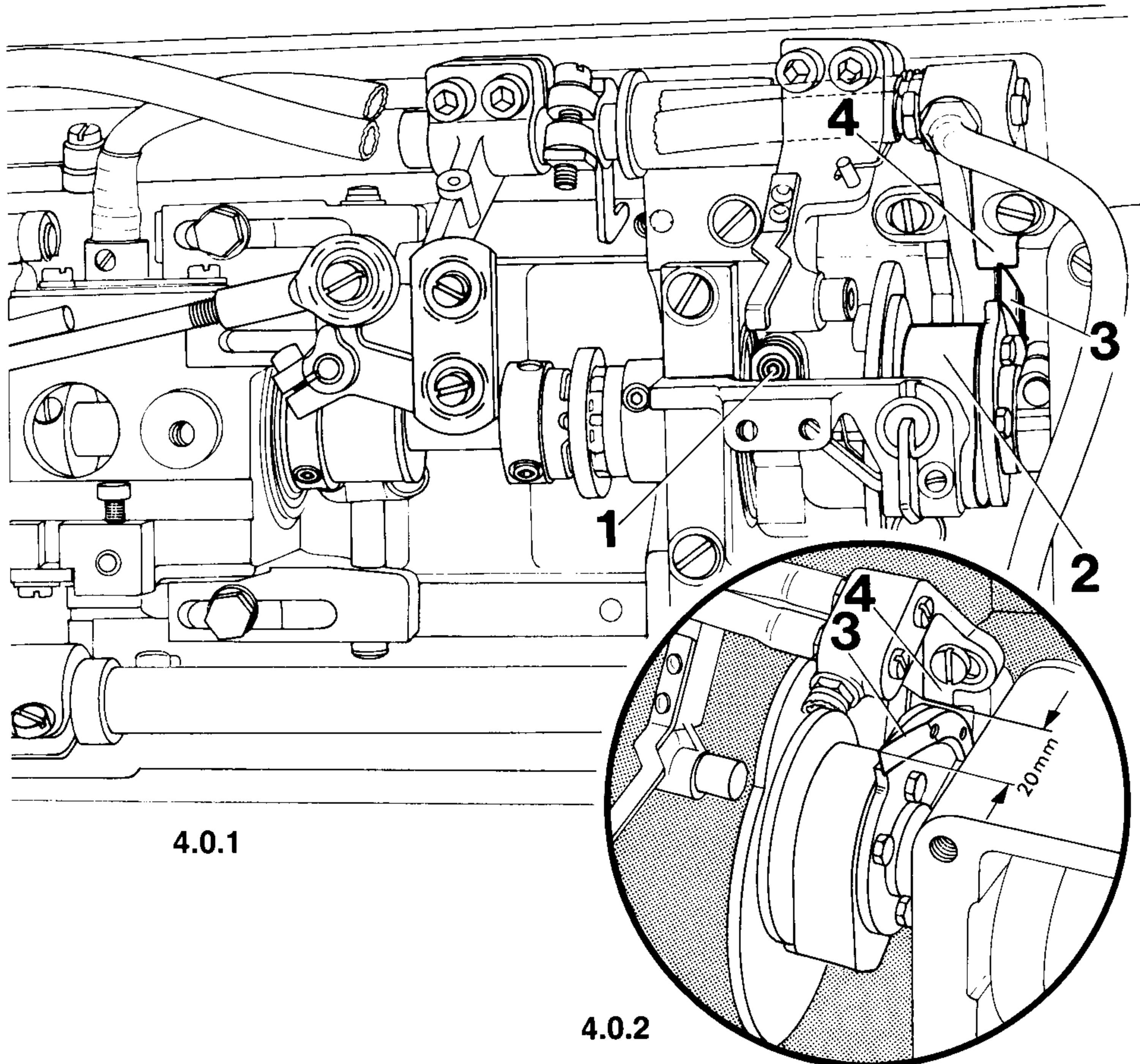

4.0.1

4.0.2

- 4.1.1 Turn the balance wheel until allen screw 1 is accessible. Loosen this screw just sufficiently to allow control cam 2 to be turned on its shaft against resistance.
- 4.1.2 Turn the balance wheel until the tip of tension control trip 3 protrudes abt. 20 mm beyond the edge of oil regulator housing bracket 4 (Fig. 4.0.2).
- 4.1.3 Push control cam 2 to the far left and hold it against spring pressure.
- 4.1.4 Turn the balance wheel backwards until a noticeable resistance is felt and hold it there.
- 4.1.5 Now, with the control cam still held to the left, continue turning the balance wheel backwards until the take-up lever is in its top position.
- 4.1.6 In this position, allow control cam 2 to spring back to its rest position. Make allen screw 1 accessible again and tighten it securely.

Correct setting:

When control cam 2 has been brought to its far left position by turning the balance wheel, with engaging lever 5 operated, there should be a clearance of abt. 0.2 mm between finger 8 and the bottom of the track of the control cam (Fig. 4.0.4).

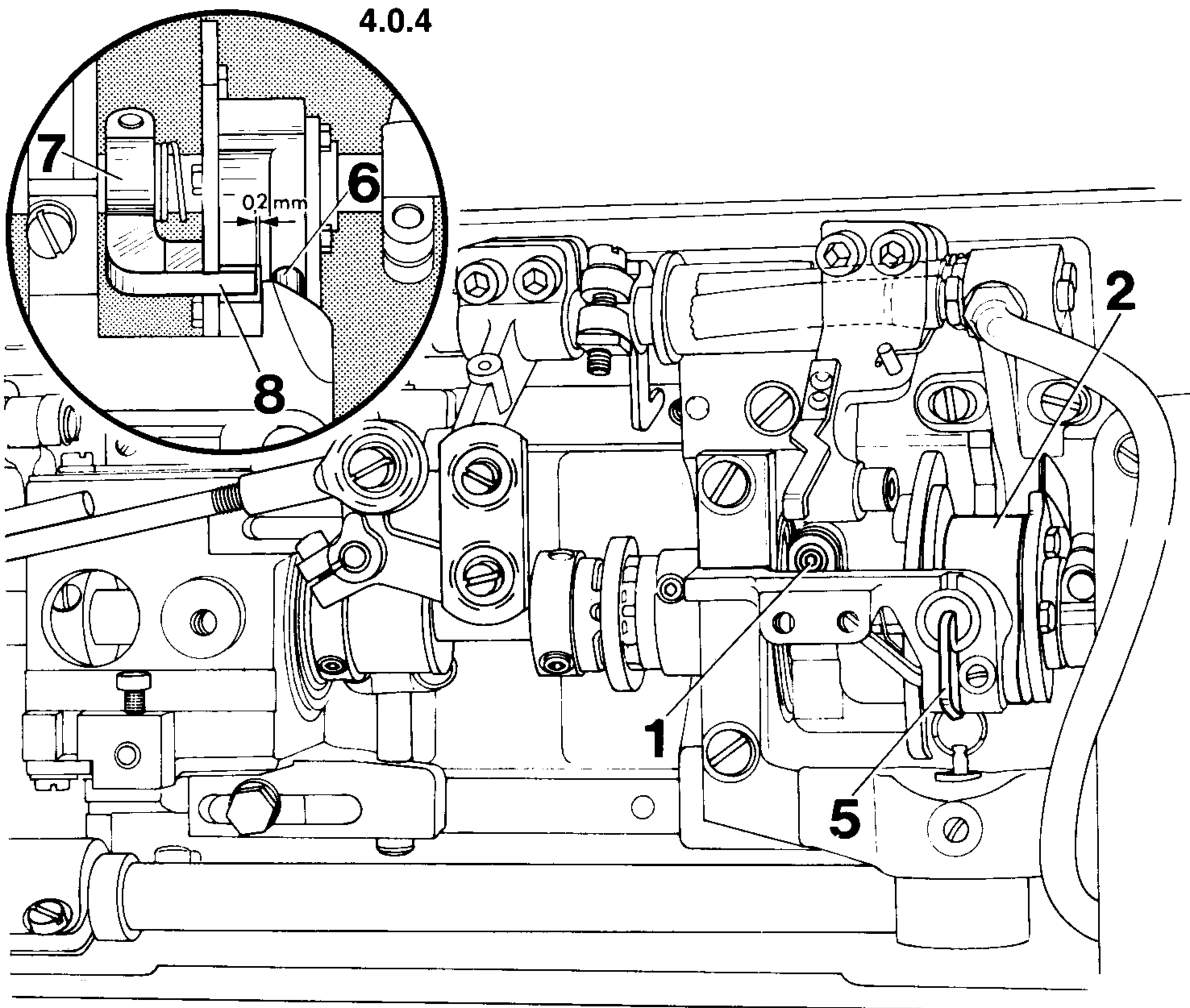

4.0.3

- 4.2.1 Make sure the take-up lever is in its top position and operate engaging lever 5.
- 4.2.2 Turn the balance wheel in its normal direction until engaging lever pin 6 has moved control cam 2 to its far left position.
- 4.2.3 Loosen allen screw 1 a little, but take care that control cam 2 is not turned.
- 4.2.4 **Retain this position, then move crank 7 laterally so that there is a clearance of abt. 0.2 mm between finger 8 and the bottom of the track of the control cam.**
- 4.2.5 In this position, tighten allen screw 1 securely.
- 4.2.6 Check this adjustment (see "Correct setting").

## 5

## Engaging solenoid

Correct setting:

With the take-up lever in its top position and engaging lever 2 operated, the plunger of the engaging solenoid should have a play of abt. 1 mm.

## 5.0.1

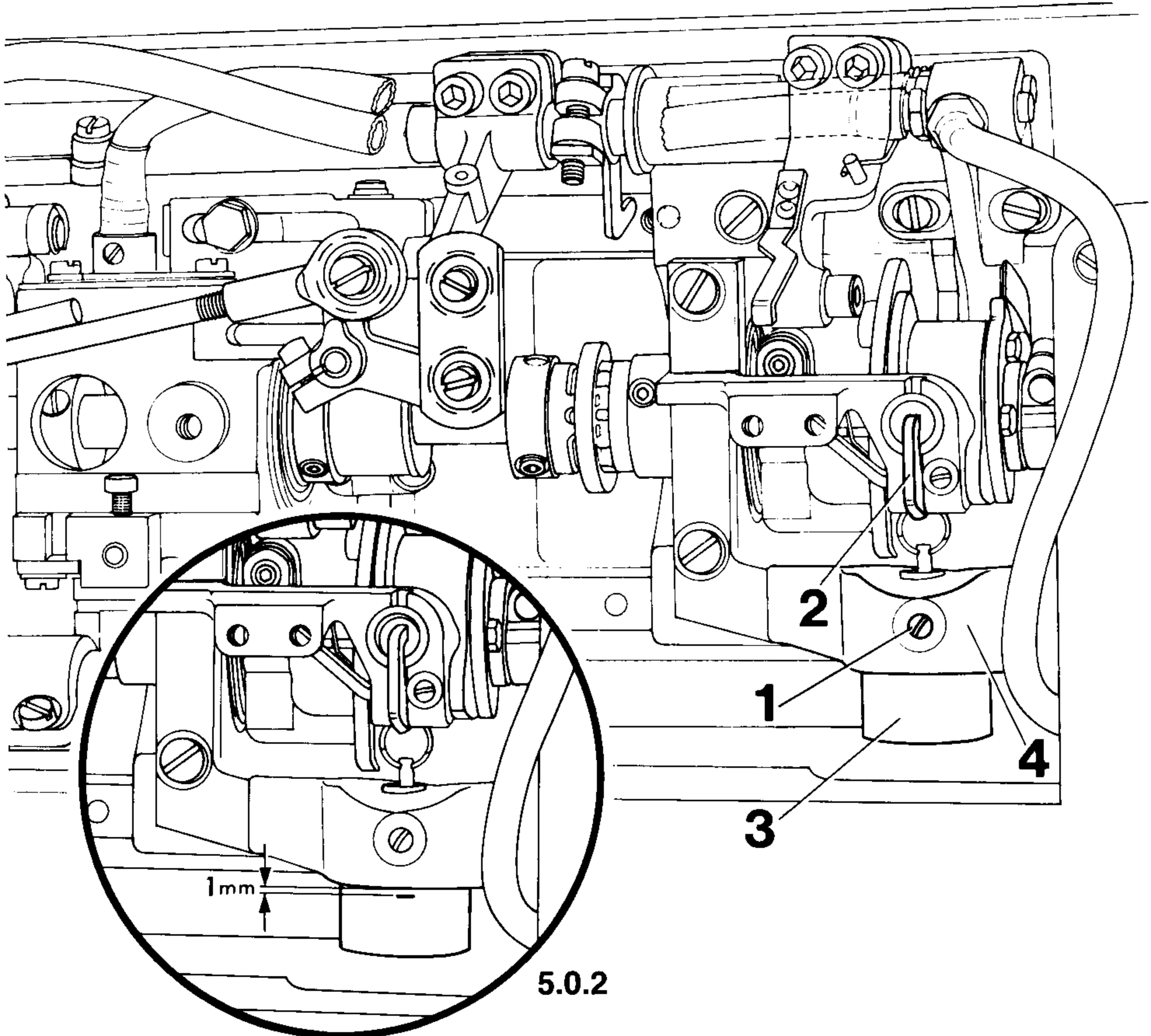

- 5.1 Turn the balance wheel to bring take-up lever to its highest point.
- 5.2 Loosen screw 1 of the engaging solenoid.
- 5.3 Operate engaging lever 2.
- 5.4 Push solenoid housing 3 upwards until the plunger is inside the housing as far as it will go.
- 5.5 In this position, make a mark on solenoid housing 3 immediately below solenoid bracket 4.
- 5.6 **Push solenoid housing 3 downwards by abt. 1 mm and tighten screw 1.**
- 5.7 Check this adjustment (see "Correct setting").



Correct setting:

With the take-up lever in its top position and the control cam pushed to the left, there should be a clearance of abt. 0.3 mm between the left outer rim of control cam 3 and pin 4 of the catcher control lever.

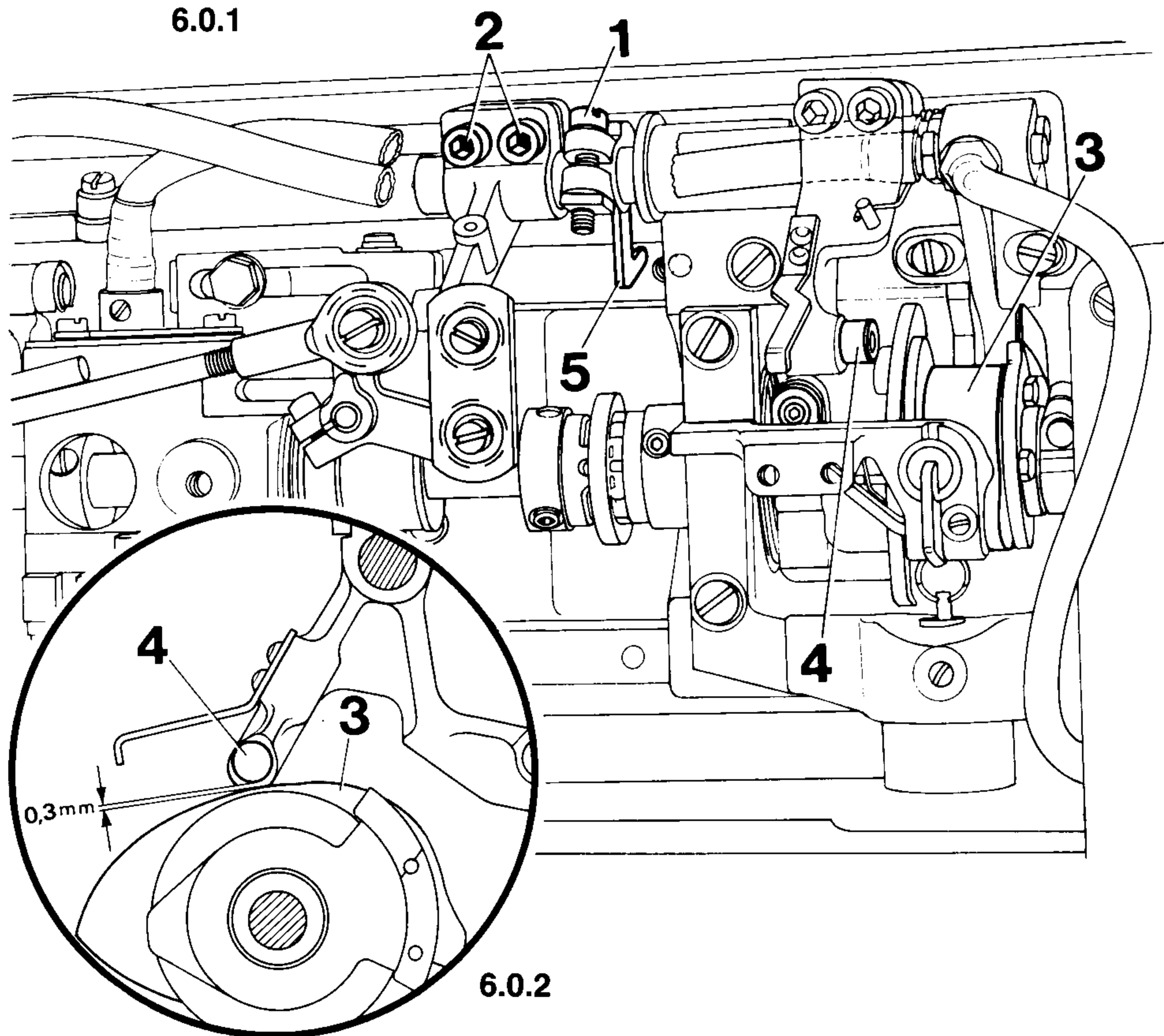

- 6.1 Turn the balance wheel to bring the take-up lever to its highest point.
- 6.2 Loosen screw 1.
- 6.3 Make sure clamp screws 2 are still loose, then push control cam 3 to the left a little and hold it there.
- 6.4 **Set a clearance of abt. 0.3 mm between pin 4 and the left outer rim of control cam 3.**
- 6.5 In this position, push stop 5 up against the casting and tighten screw 1.
- 6.6 Check this adjustment (see "Correct setting").

Correct setting:

With engaging lever **3** in its non-operative position, the upper micro switch should be actuated and the lower one released.  
When engaging lever **3** is in its operative position, the lower micro switch should be operated.

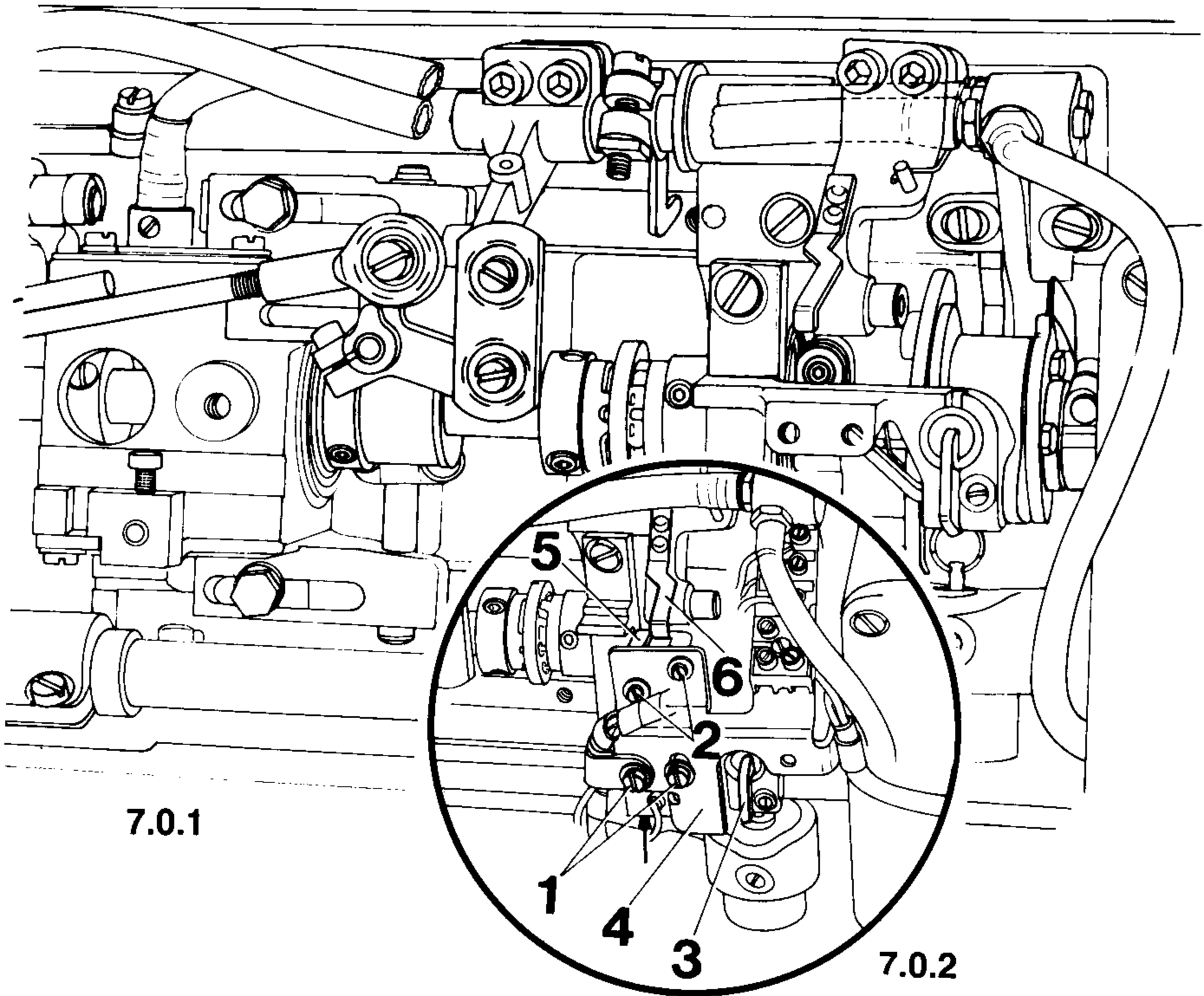

- 7.1 Fit the micro switch bracket and tighten screws **1** just a little.
- 7.2 Loosen both screws **2**.
- 7.3 Bring the take-up lever to its highest point.
- 7.4 Operate engaging lever **3**.
- 7.5 **Position micro switch bracket 4 so that the lower micro switch (see arrow) is reliably operated.**
- 7.6 In this position, tighten screws **1**.
- 7.7 Adjust the upper micro switch housing **5** vertically so that finger **6** can operate the micro switch reliably, without actually contacting the micro switch housing. (If necessary, bend finger **6** accordingly.)
- 7.8 In this position, tighten screws **2**.
- 7.9 Check: Making sure that engaging lever **3** is operated, turn the balance wheel until the take-up lever is roughly at the bottom of its stroke. In this position, finger **6** begins to lift itself off the upper micro switch. Continue turning the balance wheel until engaging lever **3** is returned to its rest position by the control cam. When the balance wheel is turned further until the take-up lever is at its highest point, the upper micro switch should again be actuated.

Correct setting:

When the control cam is at rest, ball-joint link 4 should be at right angles to the edge of the bedplate, and there should be a center-to-center distance of 22 mm between ball joints 5 and 6 (Fig. 8.0.2).

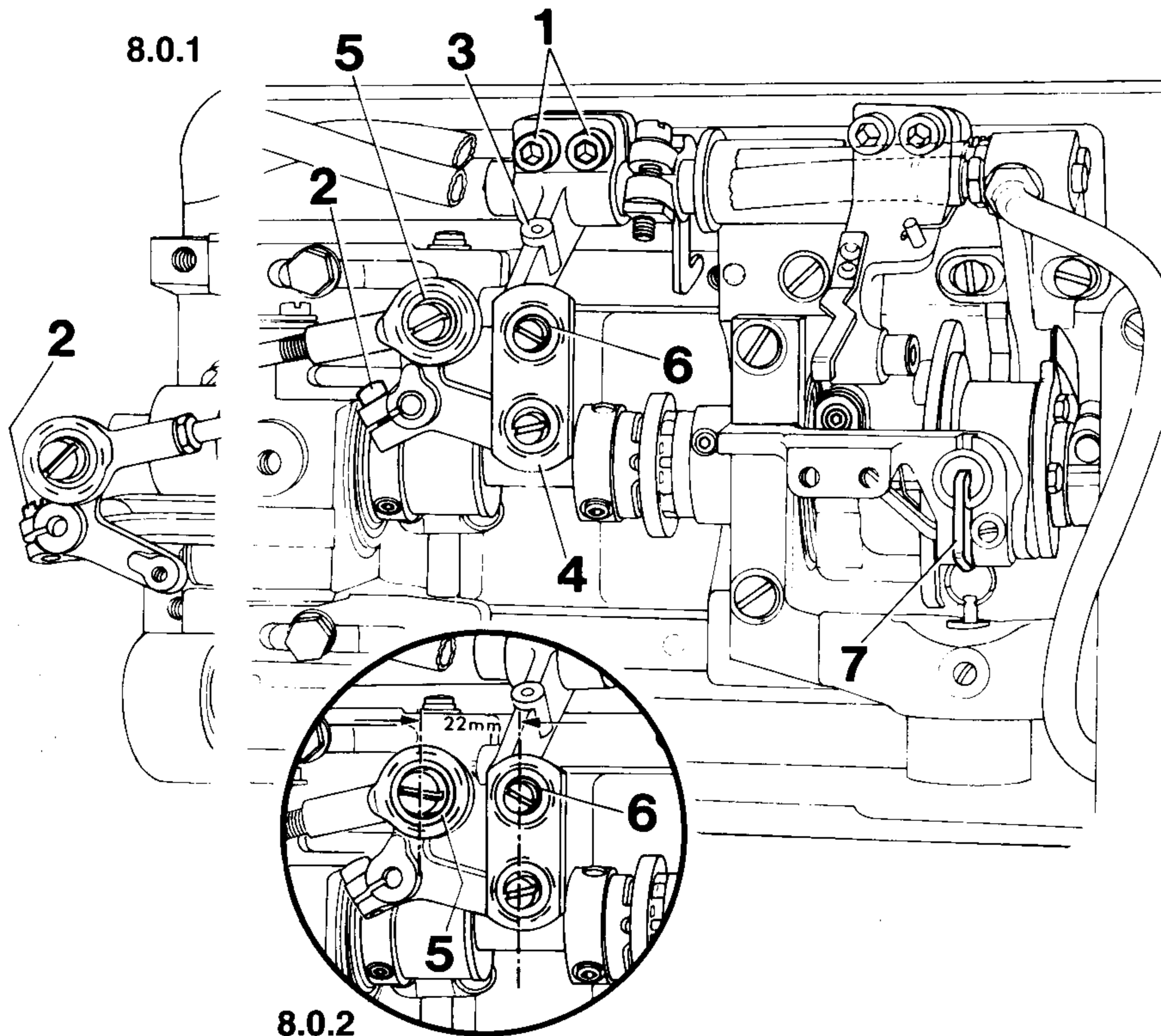

- 8.1 Make sure the control cam is in its rest position and clamp screws 1 are loose. Then loosen clamp screw 2 (two-needle machines have two such screws).
- 8.2 **Adjust catcher actuating lever 3 both endwise and radially so that ball-joint link 4 is at right angles to the edge of the bedplate and there is a center-to-center distance of 22 mm between ball joints 5 and 6 (Fig. 8.0.2).**
- 8.3 In this position, securely tighten clamp screws 1.
- 8.4 Bring the take-up lever to its highest point and operate engaging lever 7.
- 8.5 Turn the balance wheel to check that ball-joint link 4 can be moved freely at both ends of the stroke of catcher actuating lever 3.
- 8.6 If necessary, loosen clamp screws 1, adjust catcher actuating lever 3 radially, then tighten clamp screws 1 again.
- 8.7 Check this adjustment (see "Correct setting").
- 8.8 Clamp screw(s) 2 is/are left loose for adjustment of the thread catcher.

Correct  
setting:

The left bellcrank lever **3** should be parallel to the right bellcrank lever **4**.

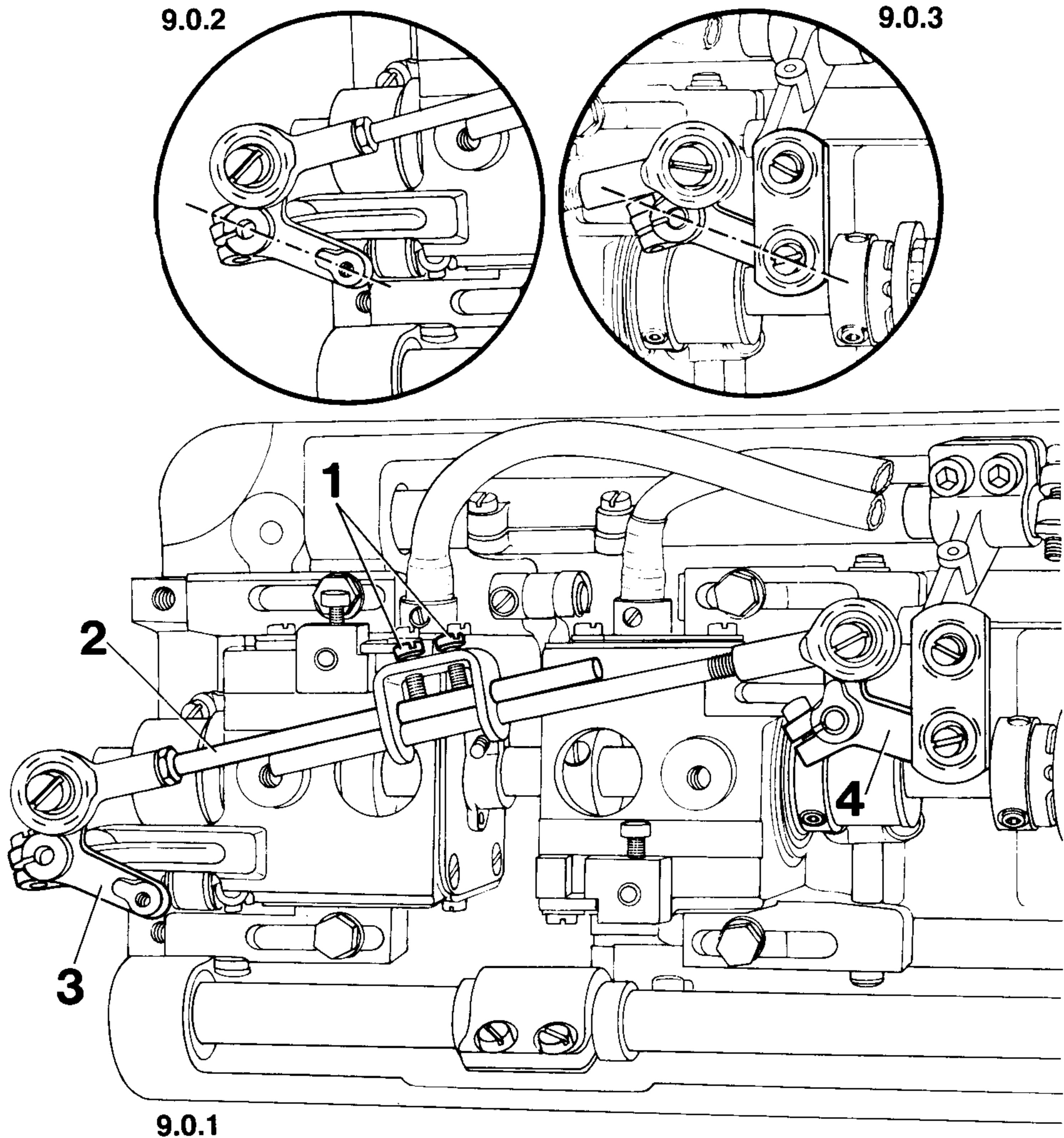

- 9.1 Make sure the control cam is in its non-operative position and loosen both screws **1**.
- 9.2 **Adjust catcher actuating connection **2** so that the left bellcrank lever **3** is parallel to the right bellcrank lever **4**.**
- 9.3 In this position, tighten screws **1**.
- 9.4 Re-adjustment may become necessary after adjustment of the catcher rest position (Section 11).

Note:

For the adjustments described in sections 11, 12, 13 and 14 remove the knife carrier.

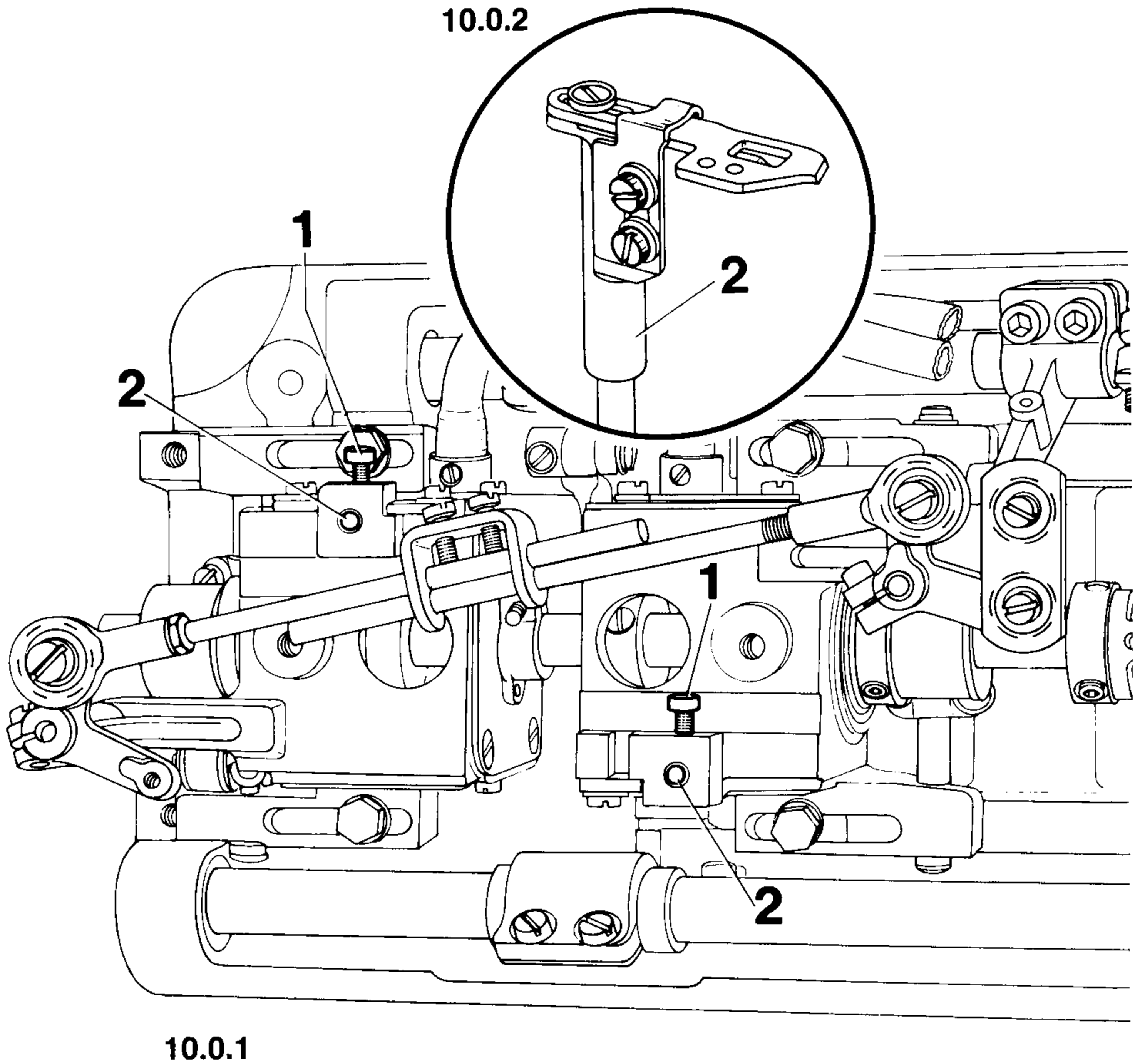

- 10.1 Remove the presser foot and the needle plate.
- 10.2 Remove the bedslide.
- 10.3 Loosen screw **1** in the hook bearing bracket.
- 10.4 Pull the complete knife carrier **2** upwards out of the machine.
- 10.5 On two-needle machines, repeat this procedure.

Correct setting:

When the control cam is in its non-operative position and clamp screw 1 has been loosened, actuating link 3 should be positioned far enough in the direction of the catcher so that the latter just begins its forward motion.

## 11.0.2

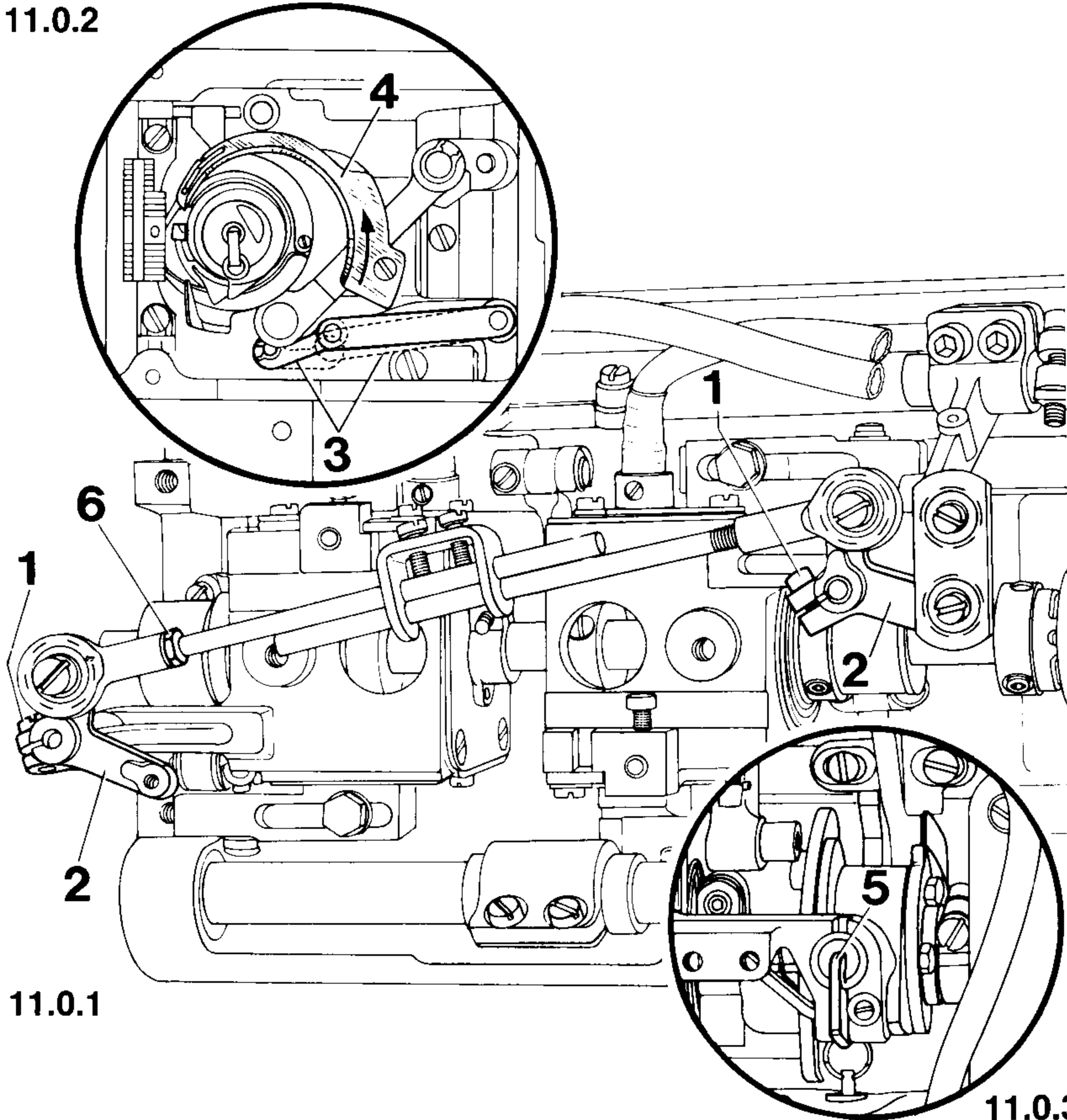

## 11.0.1

## 11.0.3

- 11.1 Make sure clamp screw 1 of bellcrank lever 2 is still loose and the control cam is in its non-operative position. **Then move actuating link 3 in the direction of thread catcher 4 until the thread catcher begins to move forward (see arrow), taking up the play.**
- 11.2 In this position, move bellcrank lever 2 upwards as far as it will go, and tighten clamp screw 1.
- 11.3 Check this adjustment (see "Correct setting").
- 11.4 On two-needle machines, repeat this adjustment.
- 11.5 Bring the take-up lever to its highest point and operate engaging lever 5.
- 11.6 Turn the balance wheel in its normal direction and bring the thread catchers to their forward point of reversal.
- 11.7 With the machine in this position both thread catchers should have advanced the same distance.
- 11.8 Make sure bellcrank lever 2 does not strike nut 6.
- 11.9 The position of the left thread catcher can be adjusted by adjusting the catcher actuating connection accordingly (Section 9).

Correct  
setting:

Thread catcher **3** should rest lightly on catcher support **2**.

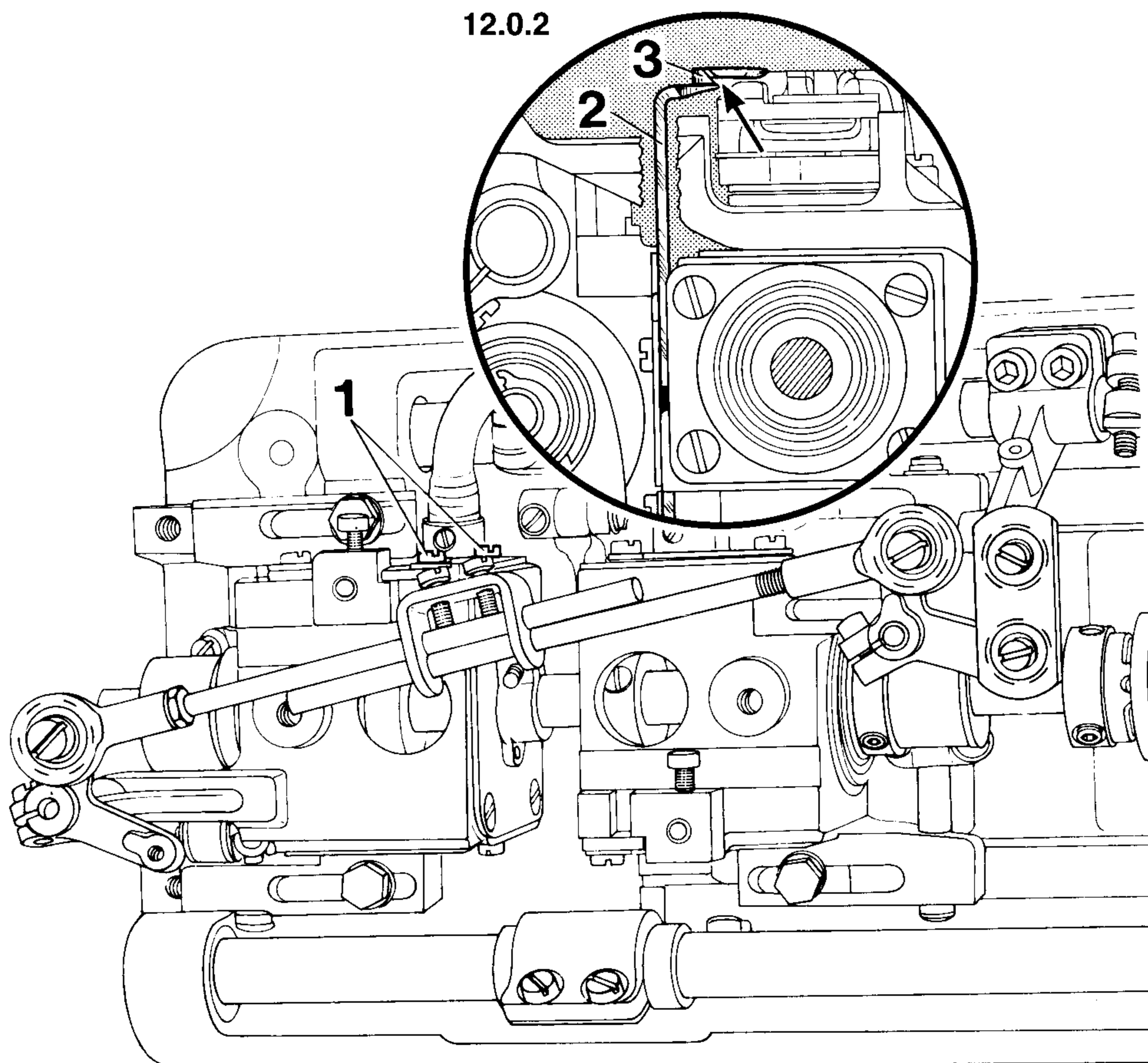

- 12.1 Make sure the control cam is in its non-operative position, and loosen screws **1**.
- 12.2 Push catcher support **2** upwards until thread catcher **3** is resting lightly on it.
- 12.3 In this position, tighten screws **1**.
- 12.4 Check this adjustment (see "Correct setting").
- 12.5 On two-needle machines repeat this adjustment.

Correct setting:

When knife 4 is pushed upwards against knife bracket 3, it should be at an angle of 89° to knife carrier 1. It should also be possible to tip the knife slightly to both sides.

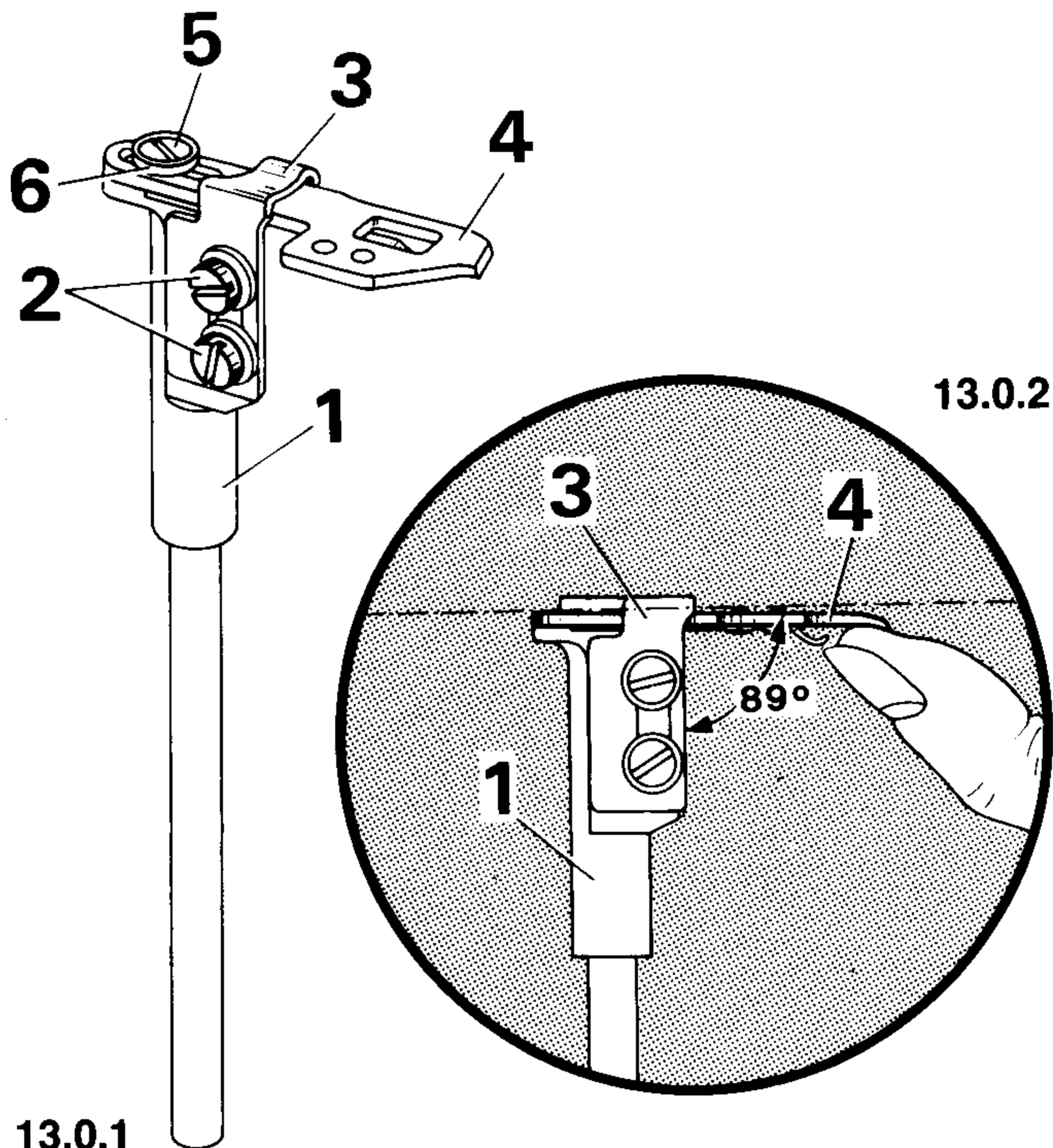

13.0.1

13.0.2

- 13.1 **Change the knife** (if necessary).
- 13.1.1 Loosen both screws 2 of bracket 3 on knife carrier 1.
- 13.1.2 Swing out knife 4 sideways and pull it out of knife carrier 1.
- 13.1.3 Take screw 5 out of guide bushing 6 and remove knife 4.
- 13.1.4 Insert guide bushing 6 into the new knife so that the two flat surfaces prevent it from turning.
- 13.1.5 Secure knife 4 on guide bushing 6 by means of screw 5. (Do not forget the washer.)
- 13.1.6 Insert guide bushing 6 together with knife 4 into knife carrier 1.
- 13.2 **Adjust the knife.**
- 13.2.1 **Adjust bracket 3 so that knife 4 is at an angle of 89° to knife carrier 1 when it is pushed upwards.**
- 13.2.2 In this position, tighten screws 2.
- 13.2.3 Check this adjustment (see "Correct setting").
- 13.2.4 On two-needle machines repeat this adjustment and change both knives.



## 14 Thread nipper spring

Correct setting:

The tongue of thread nipper spring **3** should be parallel to the sides of the cutout in knife **4** and should move upwards freely.

Note:

The clearance between the tongue of thread nipper spring **3** and the cutout of knife **4** (in longitudinal direction) is dependent of the thread used and may have to be adjusted after a trimming test.

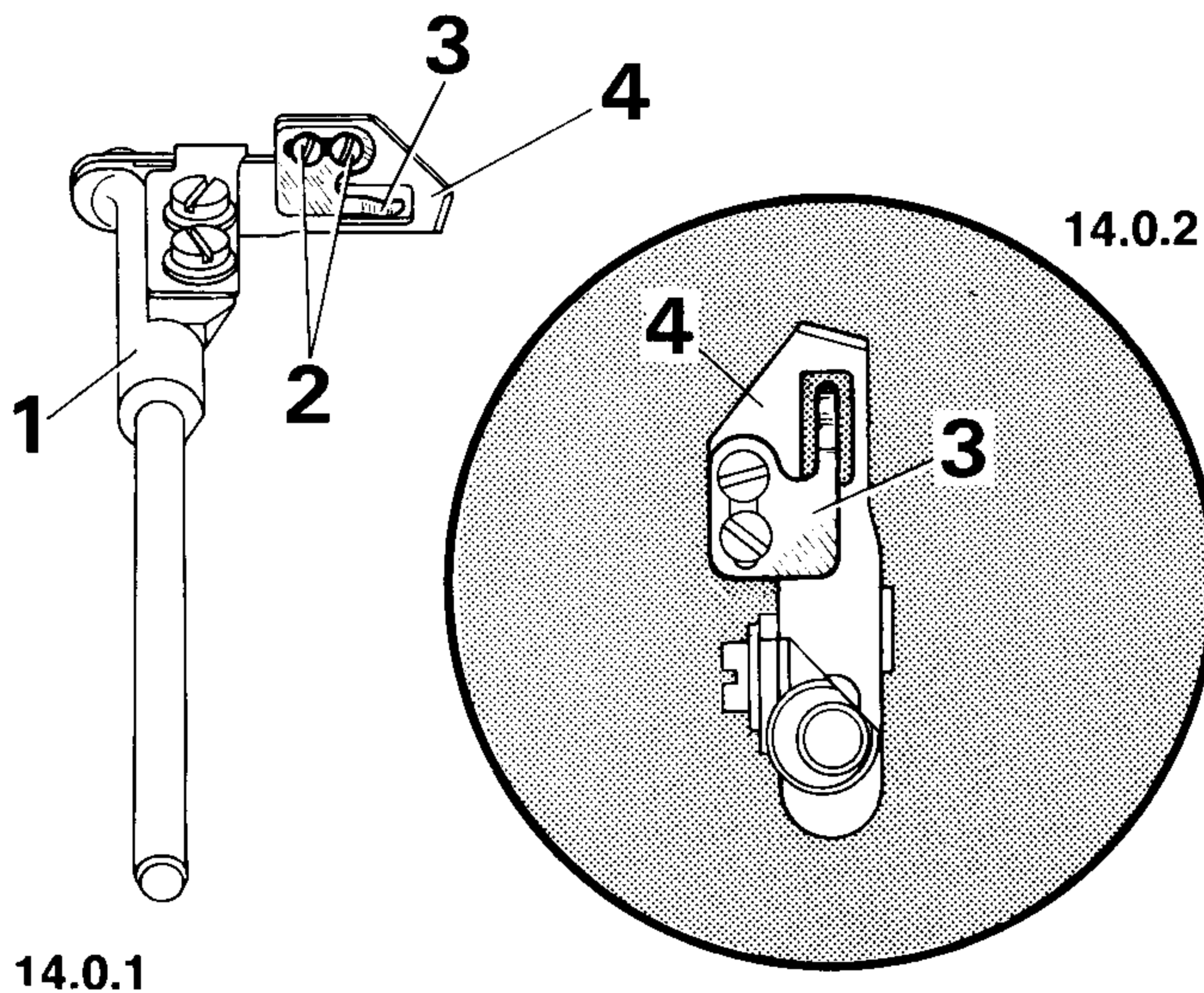

- 14.1 Loosen both screws **2** on the dismantled knife carrier **1**.
- 14.2 **Adjust thread nipper spring **3** so that its tongue is parallel to the sides of the cutout in knife **4** and can move freely upwards.**
- 14.3 In this position, tighten both screws **2**.
- 14.4 Check this adjustment (see "Correct setting").
- 14.5 Replace the complete knife carrier **1** in the hook bearing bracket from above, but do not screw it down.
- 14.6 On two-needle machines repeat this adjustment.

Correct setting:

When at rest, the tip of thread catcher 3 should protrude beyond the cutting edge of knife 2 by abt. 1 mm. Also, the tongue of thread nipper spring 4 should be positioned in the groove of thread catcher 3.

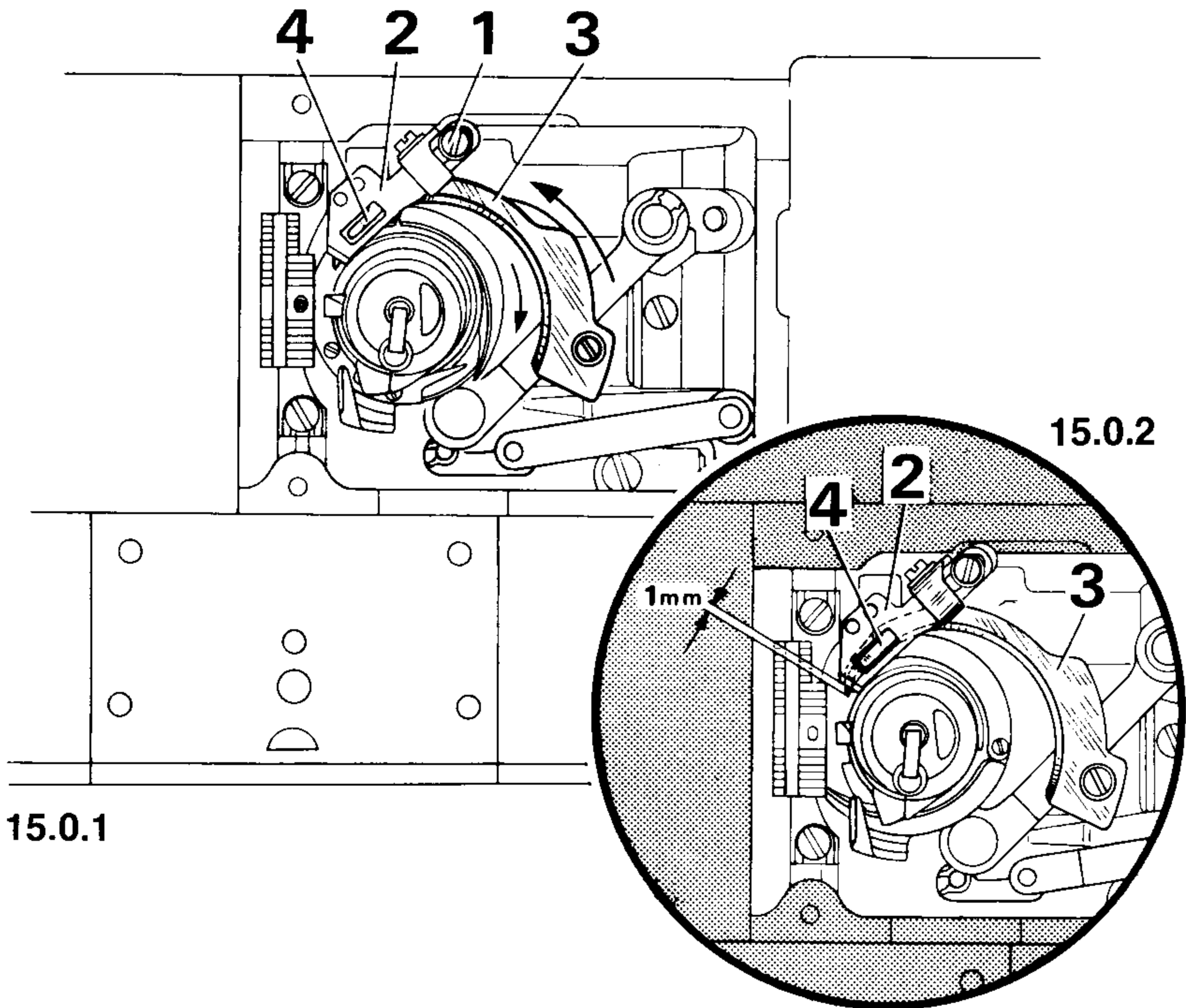

- 15.1 Loosen screw 1 just a little, making sure the guide bushing does not twist in the elongated hole in the knife.
- 15.2 **Reposition knife 2 lengthwise so that the tip of thread catcher 3 protrudes beyond the cutting edge of knife 2 by abt. 1 mm, when the thread catcher is at rest.**
- 15.3 In this position, securely tighten screw 1.
- 15.4 **Adjust knife 2 laterally so that the tongue of thread nipper spring 4 is positioned in the groove of thread catcher 3.**
- 15.5 **Press lightly on the knife carrier to produce the necessary cutting pressure. As you do so, check to make sure that the knife rests on the catcher with its cutting edge only. There should be a small light gap between knife 2 and thread catcher 3.**
- 15.6 In this position, securely tighten screw 1 of the knife carrier (Fig. 10.0.1).
- 15.7 **Trimming test:**
- 15.7.1 Turn the balance wheel to bring the take-up lever to its highest point.
- 15.7.2 Operate the engaging lever by hand.
- 15.7.3 Continue turning the balance wheel until thread catcher 3 is at its forward point of reversal.
- 15.7.4 Insert two threads in the hole of the thread catcher and continue turning the balance wheel in its normal direction until the thread catcher returns to its rest position; both threads must be cut perfectly in the process.
- 15.8 Replace and screw on presser foot and needle plate.
- 15.9 On two-needle machines repeat this adjustment and the trimming test.

Correct setting:

When the presser foot is lowered onto the needle plate and dog 1 has actuated tension release trip 2 there should be a clearance of at least 0.5 mm between both tension discs.

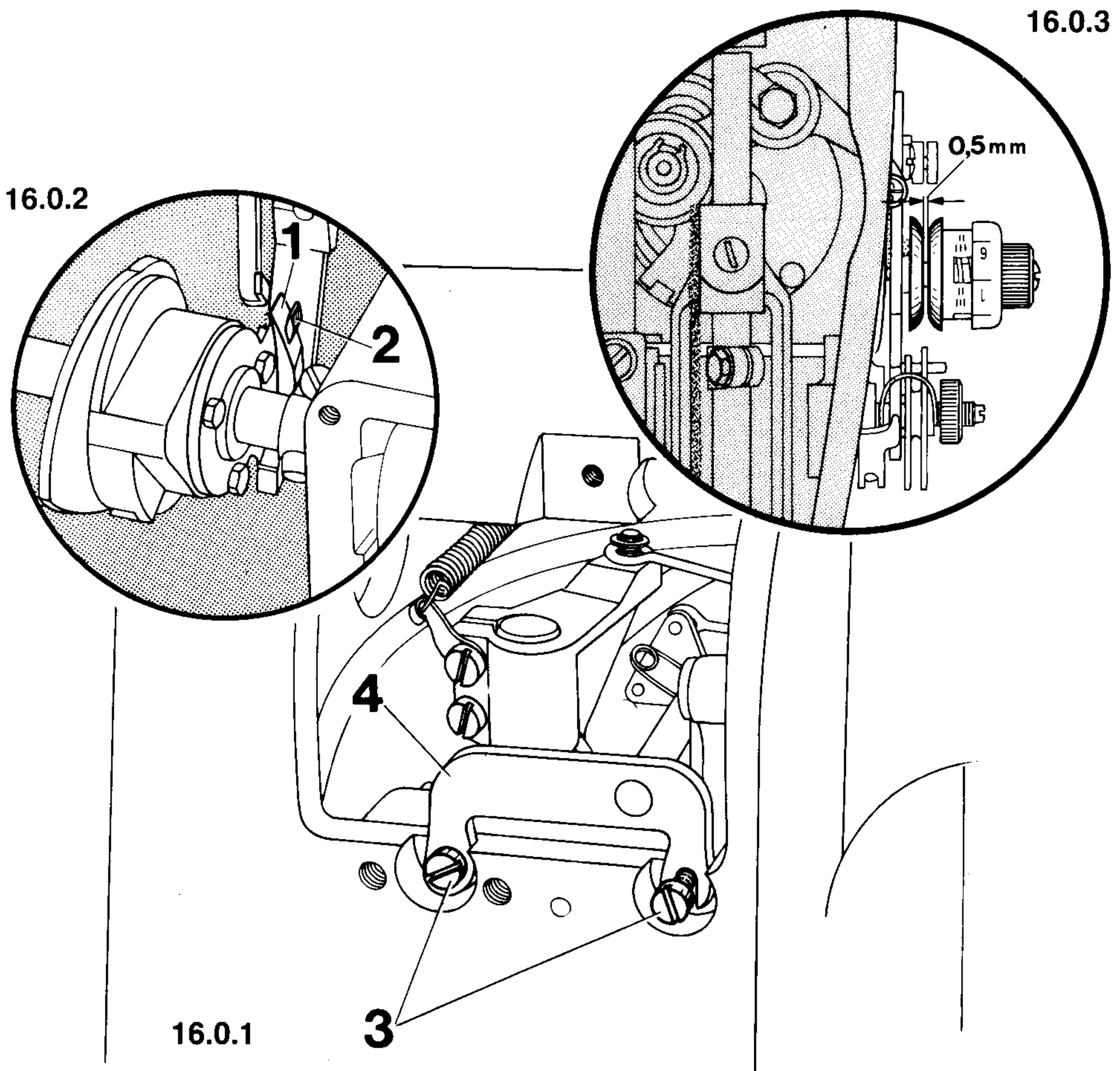

- 16.1 Lower the presser foot onto the needle plate by operating the presser bar lifter.
- 16.2 Bring the take-up lever to its highest point and operate the engaging lever.
- 16.3 Turn the balance wheel until dog 1 has actuated tension release trip 2.
- 16.4 Loosen screws 3.
- 16.5 **Move bracket 4 in the elongated hole until the clearance between both tension discs amounts to at least 0.5 mm.**
- 16.6 In this position, tighten screws 3.
- 16.7 Check this adjustment (see "Correct setting").

Correct setting:

Thread catcher **3** should begin to move forwards when needle thread **2**, which has been picked up by the hook point **1**, contacts bobbin case cap **4**.

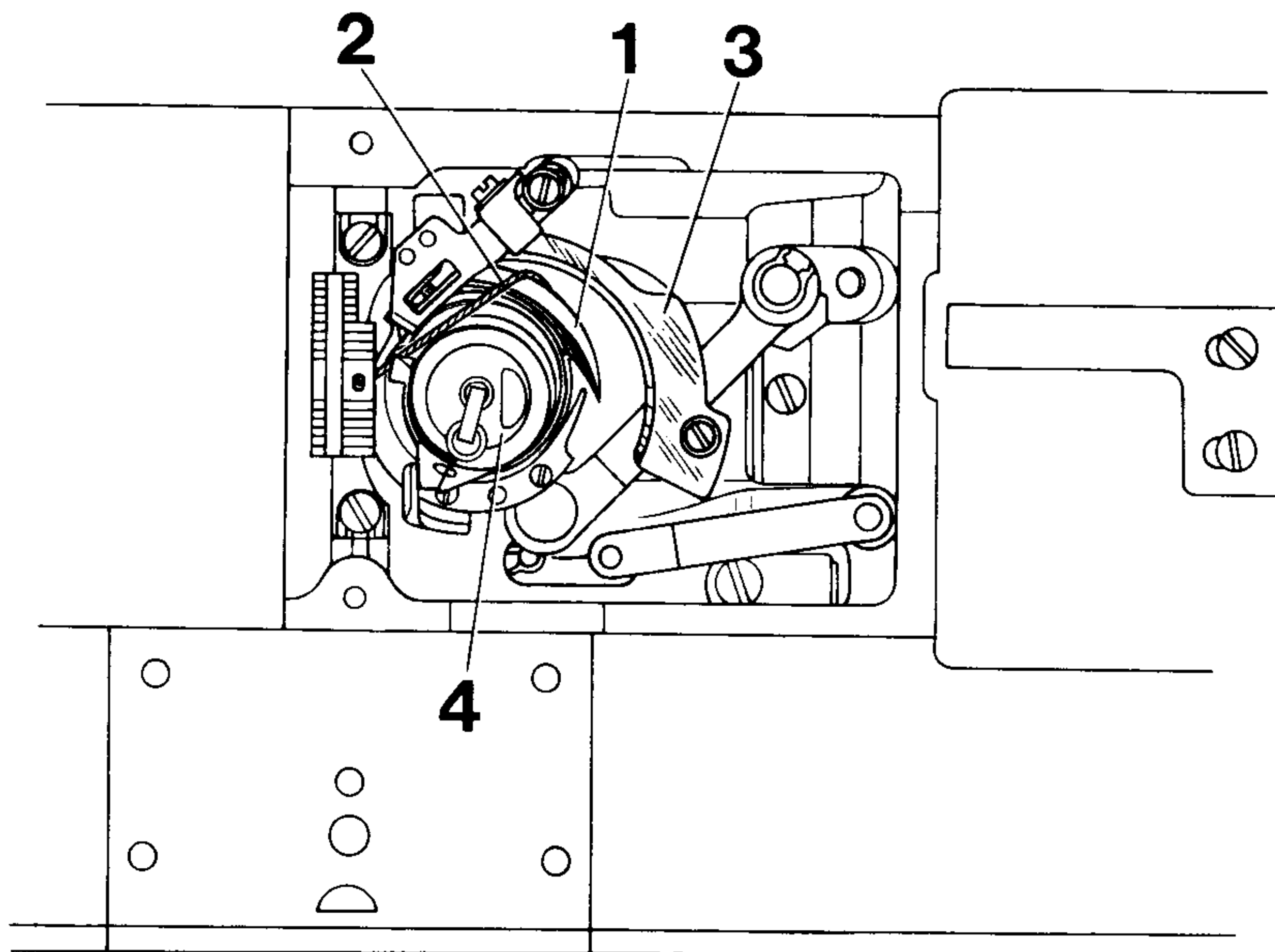

### 17.0.1

- 17.1 Thread the needle.
- 17.2 Turn the balance wheel to bring the take-up lever to its highest point.
- 17.3 Operate the engaging lever.
- 17.4 Continue turning the balance wheel in its normal direction until needle thread **2**, which has been picked up by hook point **1**, contacts bobbin case cap **4**.
- 17.5 At this precise moment thread catcher **3** should begin to move forwards.
- 17.6 **If thread catcher 3 moves forwards earlier or later, adjust the control cam accordingly (see Section 4).**
- 17.7 On two-needle machines check the second thread catcher, too.

18

Preliminary adjustment of synchronizer

18.1

Single-needle machines with lever-operated Quick-Stop motor, Type 700.

Correct setting:

After thread trimming the machine should stop with the take-up lever at top dead center. When sewing is interrupted, the machine should stop with the needle bar at a position abt. **4 mm** before bottom dead center.

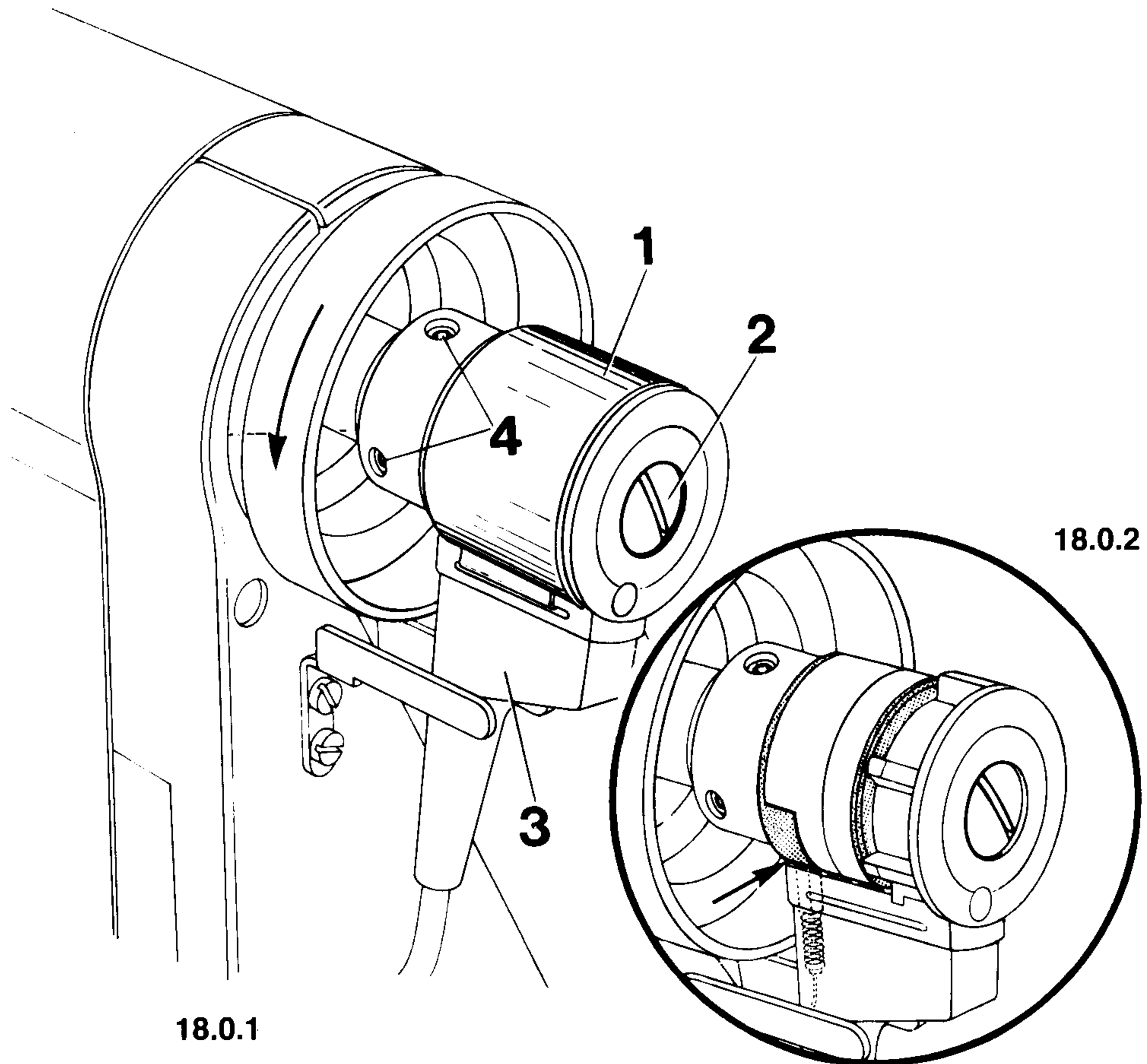

18.0.1

18.0.2

- 18.1.1 Remove cap **1** and loosen screw **2** of synchronizer **3**.
- 18.1.2 Loosen both screws **4**.
- 18.1.3 Turn the balance wheel to bring the needle bar to a position **4 mm** before bottom dead center.
- 18.1.4 **In this position, center the inner switch-off segment exactly over the carbon brush and tighten screws 4.**
- 18.1.5 Turn the balance wheel to bring the take-up lever to top dead center.
- 18.1.6 **In this position, center the outer switch-off segment exactly over the carbon brush and tighten screw 2.**
- 18.1.7 Switch on the machine and check this adjustment (see "Correct setting").
- 18.1.8 Replace cap **1**.

Correct  
setting:

At a sewing interruption and after thread trimming the machine should stop with the take-up lever at top dead center.

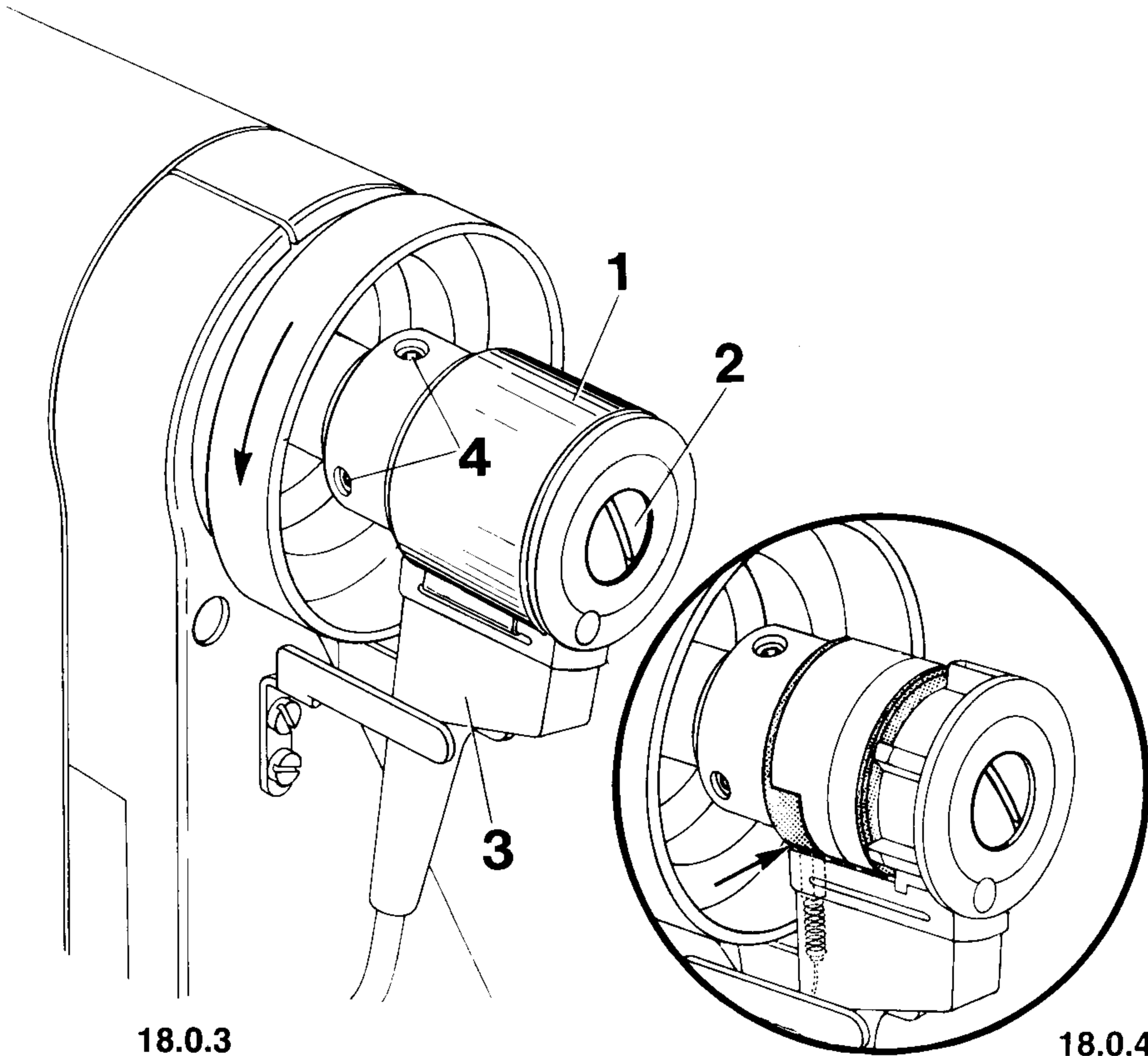

18.0.3

18.0.4

- 18.2.1 Remove cap 1 and loosen screw 2 of synchronizer 3.
- 18.2.2 Loosen both screw 4.
- 18.2.3 Turn the balance wheel to bring the needle bar to a position 2 mm past bottom dead center.
- 18.2.4 **In this position, center the inner switch-off segment exactly over the carbon brush (see arrow) and tighten screws 4.** (This is no stopping position).
- 18.2.5 Turn the balance wheel to bring the take-up lever to top dead center.
- 18.2.6 **In this position, center the outer switch-off segment exactly over the carbon brush and tighten screw 2.**
- 18.2.7 Switch on the machine and check this adjustment (see "Correct setting"). Re-adjust, if necessary.
- 18.2.8 Replace cap 1.

Correct setting:

In take-up-lever up position the yellow-marked magnet in the outer magnet bracket 7 should be positioned above the opposite pole (Fig. 18.0.5).  
When the needle bar is at a position 4 mm before bottom dead center, the red-marked magnet in the inner magnet bracket 8 should also be positioned above the opposite pole (Fig. 18.0.6).

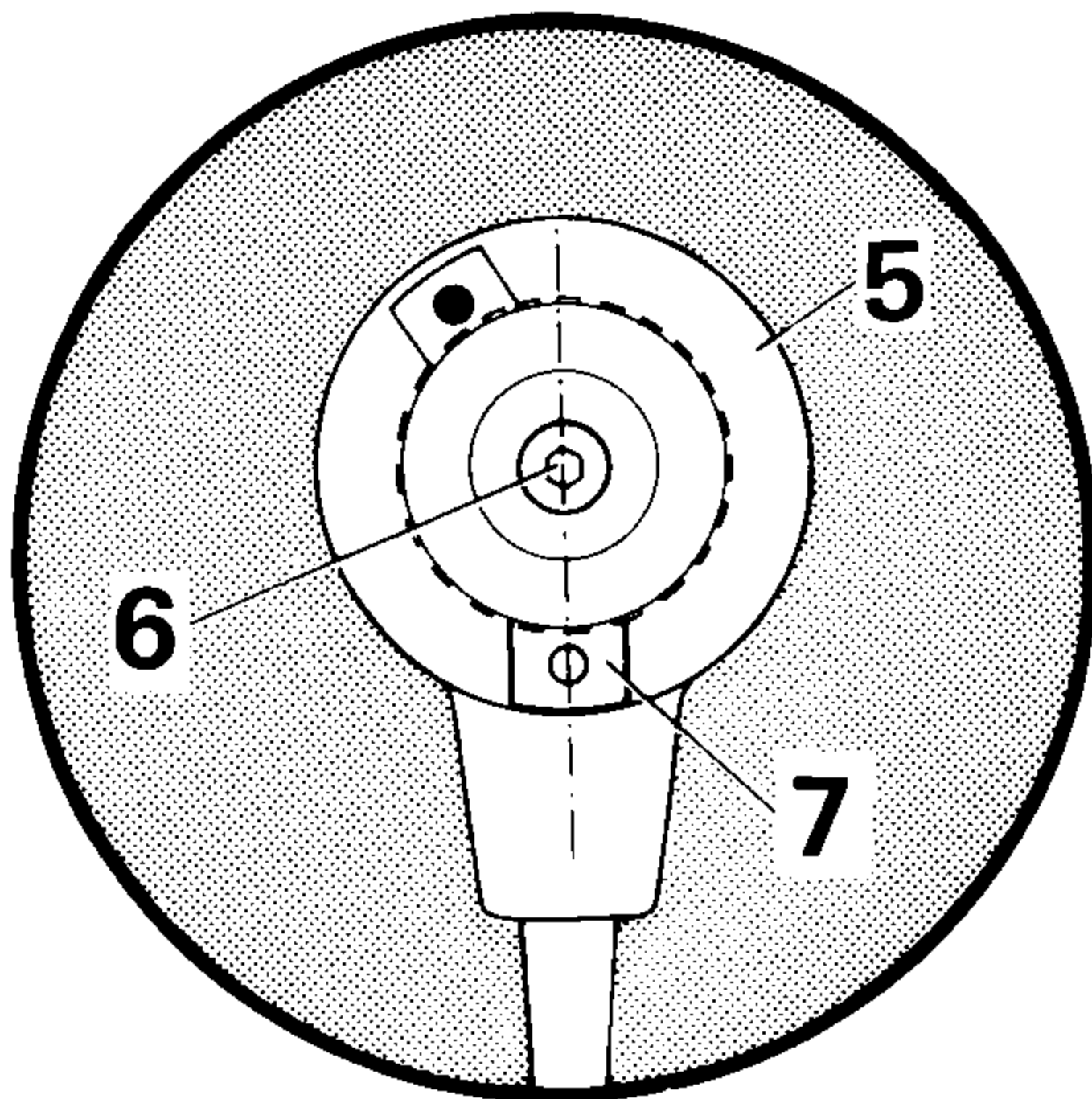
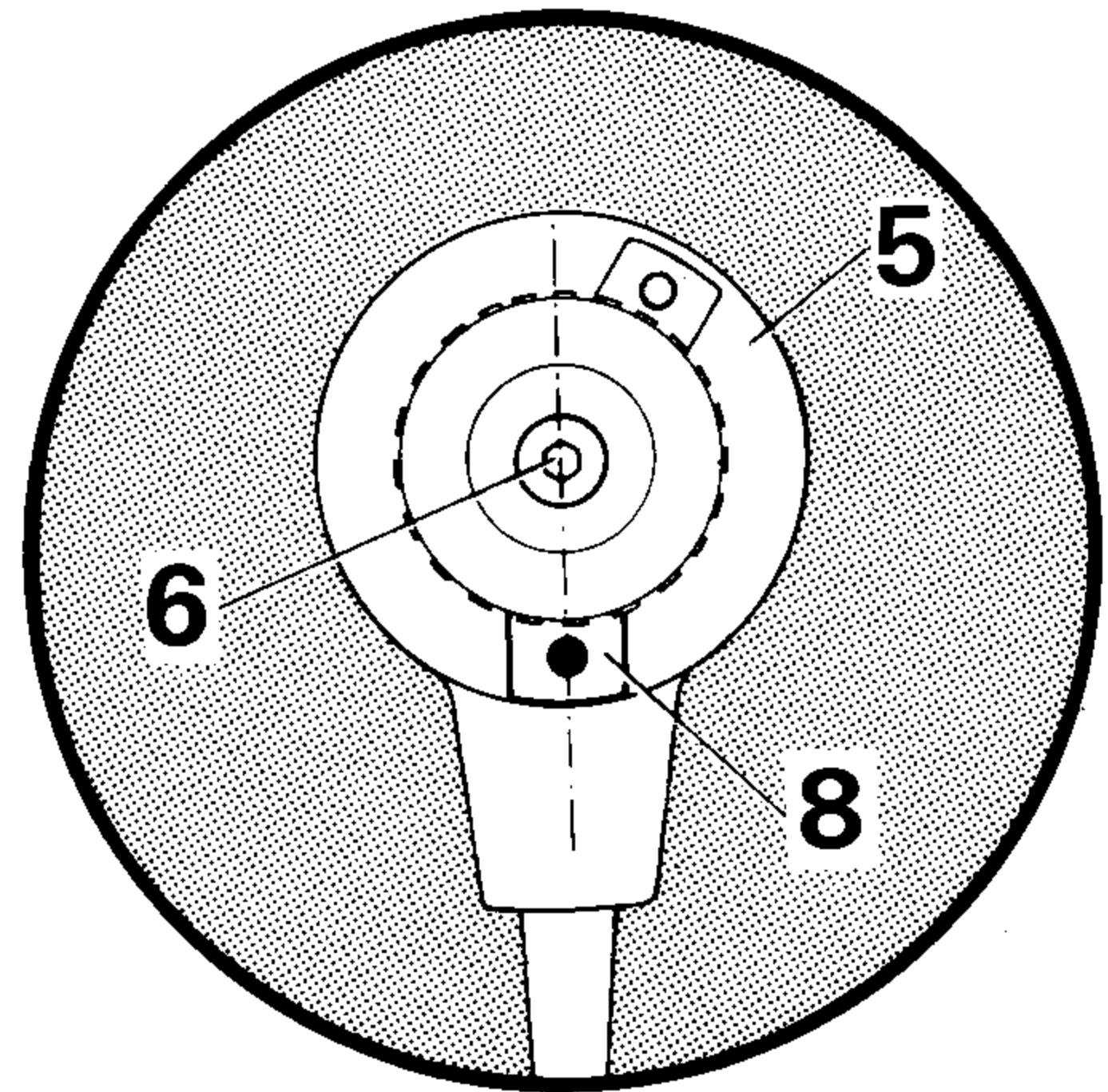
**18.0.5****18.0.6**

- 18.3.1 Pull the protecting cap off synchronizer 5 on the balance wheel.
- 18.3.2 Loosen screw 6.
- 18.3.3 Bring the take-up lever to top dead center.
- 18.3.4 **Set the outer magnet bracket 7 with its yellow-marked magnet above the opposite pole at the bottom (Fig. 18.0.5).**
- 18.3.5 Bring the needle bar to a position 4 mm before bottom dead center.
- 18.3.6 **Set the inner magnet bracket 8 with its red-marked magnet above the opposite pole at the bottom ( Fig. 18.0.6).**
- 18.3.7 In this position, tighten screw 6.
- 18.3.8 Switch on the machine.
- 18.3.9 Check both positions by pedal control.
- 18.3.10 Replace the protecting cap of synchronizer 5.

Note: The position "4 mm before bottom dead center of needle bar" on two-needle machines can be cancelled by means of a toggle switch so that the machine will always stop with the needle positioned at take-up-lever up position.

18.4 **Single- and two-needle machines with Efka-Variostop motor, Type V (control systems 5G20 and 5G21)**

Correct setting:

When the slot of inner control disc 3 is positioned between the projections of the induction coil, the machine should stop with the needle bar at a position 4 mm before bottom dead center. When the slot of outer control disc 4 is positioned between the projections of the induction coil, the machine should stop at take-up-lever up position.

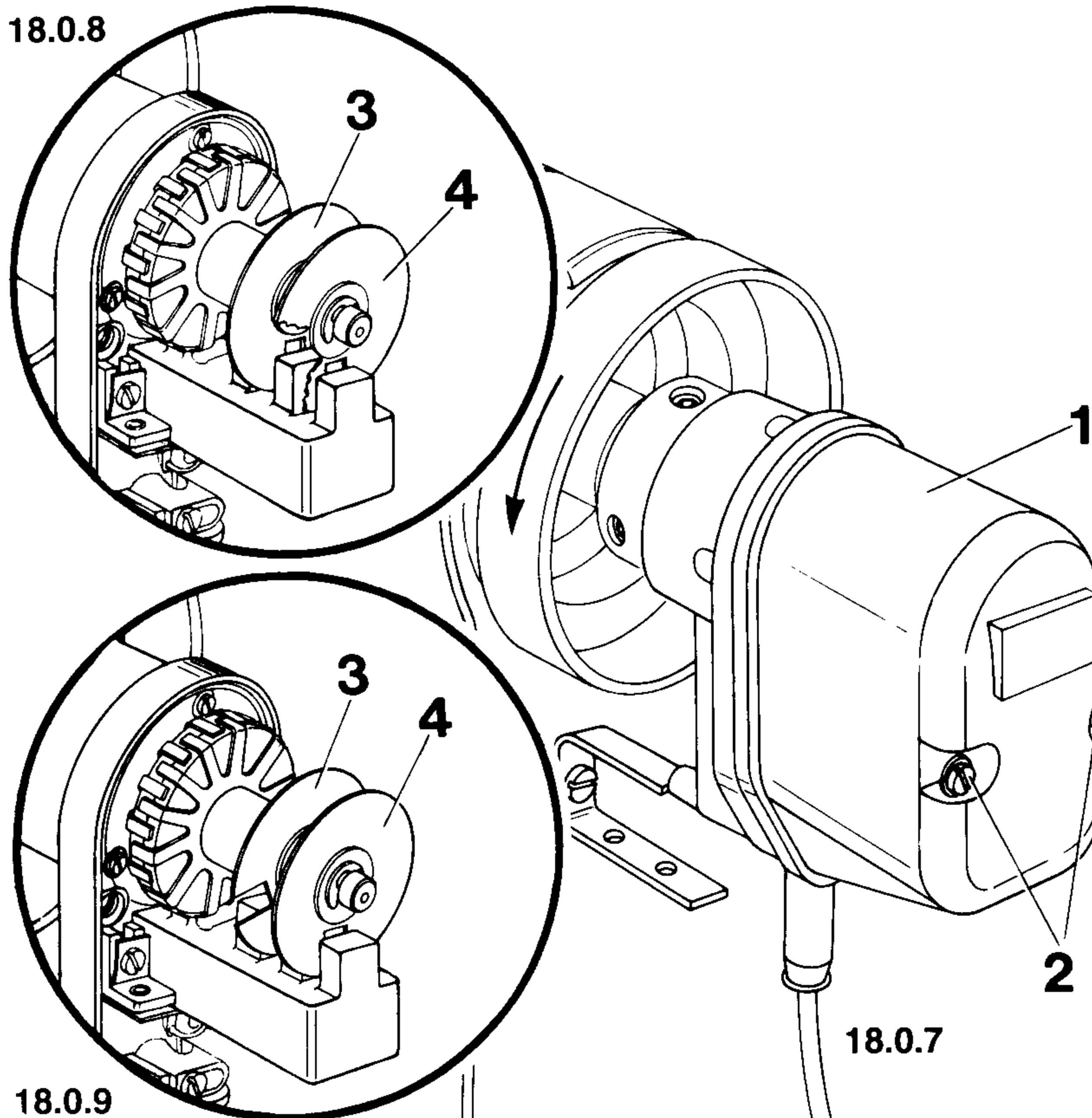

- 18.4.1 Loosen both screws 2 of synchronizer cover 1 and remove the latter.
- 18.4.2 Bring the needle bar to a position 4 mm before bottom dead center.
- 18.4.3 **In this position, turn inner control disc 3 until its slot is positioned between the projections of the induction coil.**
- 18.4.4 Turn the balance wheel to bring the take-up lever to its highest point.
- 18.4.5 **In this position, turn outer control disc 4 until its slot is positioned between the projections of the induction coil.**
- 18.4.6 Switch on the machine.
- 18.4.7 Check the positions by pedal control and, if necessary, adjust.
- 18.4.8 Replace and screw on cover 1.
- Note: The position "4 mm past bottom dead center of needle bar" on two-needle machines can be cancelled by means of a toggle switch so that the machine will always stop with the needle positioned at take-up-lever up position.



19

### Micro switches "b3" and "b5"

(only on machines with lever-operated Quick-Stop motor, Type 700)

19.1

### Single-needle machines wired according to circuit diagram No. 91-095 750-95

For easy identification the four pins are marked clockwise from A to D. The numbers in parentheses from 12 to 15 indicate the wires connected to them. The pin next to the earth symbol is pin D.

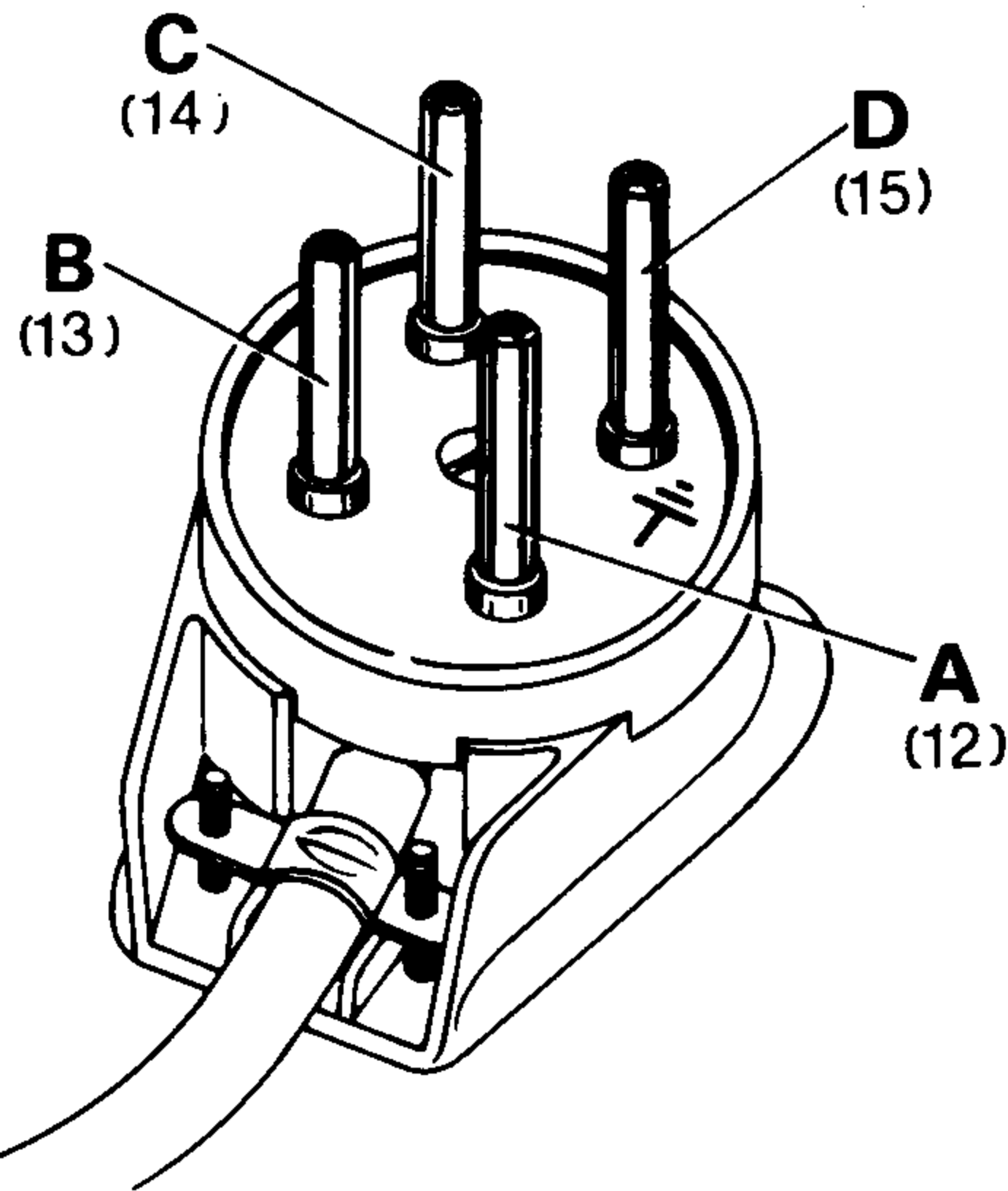

#### 19.0.1

- 19.1.1 Pull the four-pin plug out of the motor control panel socket marked "Synchronisator-Steckvorrichtung".
- 19.1.2 Lower the presser foot onto the needle plate.
- 19.1.3 Turn the balance wheel until the trimming mechanism is at rest.
- 19.1.4 Turn the balance wheel further until the inner switch-off track is positioned under the carbon brush.
- 19.1.5 In this position, **no** current must flow between pins A and C as well as A and D.
- 19.1.6 Operate the engaging lever by hand, which action operates the two micro switches "b3".
- 19.1.7 In this position, current must flow between pins A and C. However there must be **no** flow of current between pins A and D.
- 19.1.8 Turn the balance wheel to return the trimming mechanism to its rest position.
- 19.1.9 Continue turning the balance wheel until the outer track is positioned under the carbon brush.
- 19.1.10 In this position, **no** current must flow between pins A and C. However current must flow between pins A and D.
- 19.1.11 On machines on which the needle up position does not set off the trimming action (subcl. -913/03) push the knee lever to the right as far as it will go (which action operates micro switch "b5").
- 19.1.12 In this position, **no** current must flow between pins A and D.
- 19.1.13 If micro switch "b5" does not switch over when the knee lever is operated, adjust the two nuts on the connecting rod to the right of the actuating bracket accordingly.
- 19.1.14 If the switches do not work properly, check all connections and switches.

19.2 **Two-needle machines wired according to circuit diagram No. 91-190 001-95.**

Note: For easy identification, the pins of the special five-pin plug are marked 1 to 5.

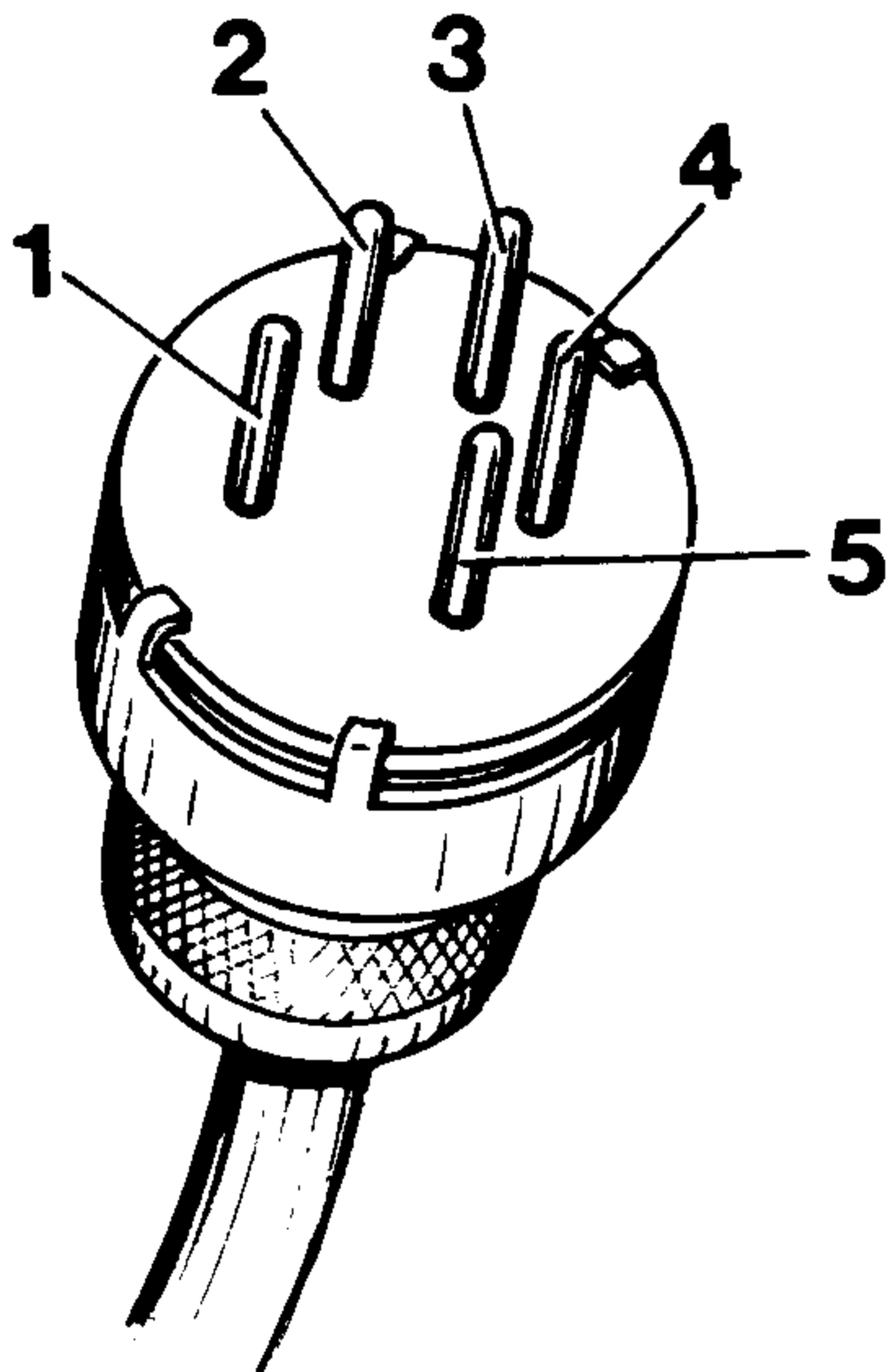

**19.0.2**

- 19.2.1 Turn the balance wheel until the right switch-off segment of the synchronizer is centered above carbon brush.
- 19.2.2 In this position, **no** current must flow between pins **1** and **2**. To check this, use a circuit tester.
- 19.2.3 Turn the balance wheel further until the left switch-off segment of the synchronizer is centered above the carbon brush.
- 19.2.4 In this position, there must be **no** flow of current between pins **1** and **3** as well as **1** and **5**.
- 19.2.5 Operate the engaging lever by hand, which action switches over micro switches "b3" and "b5".
- 19.2.6 In this position, current must flow between pins **1** and **3** as well as **1** and **5**.
- 19.2.7 Turn the balance wheel in its normal direction until the trimmer shaft springs back to its rest position.
- 19.2.8 In this position, **no** current must flow between pins **1** and **3** as well as **1** and **5**.

**Motor connecting rod**

(on machines with lever-operated Quick-Stop motor only)

Correct setting:

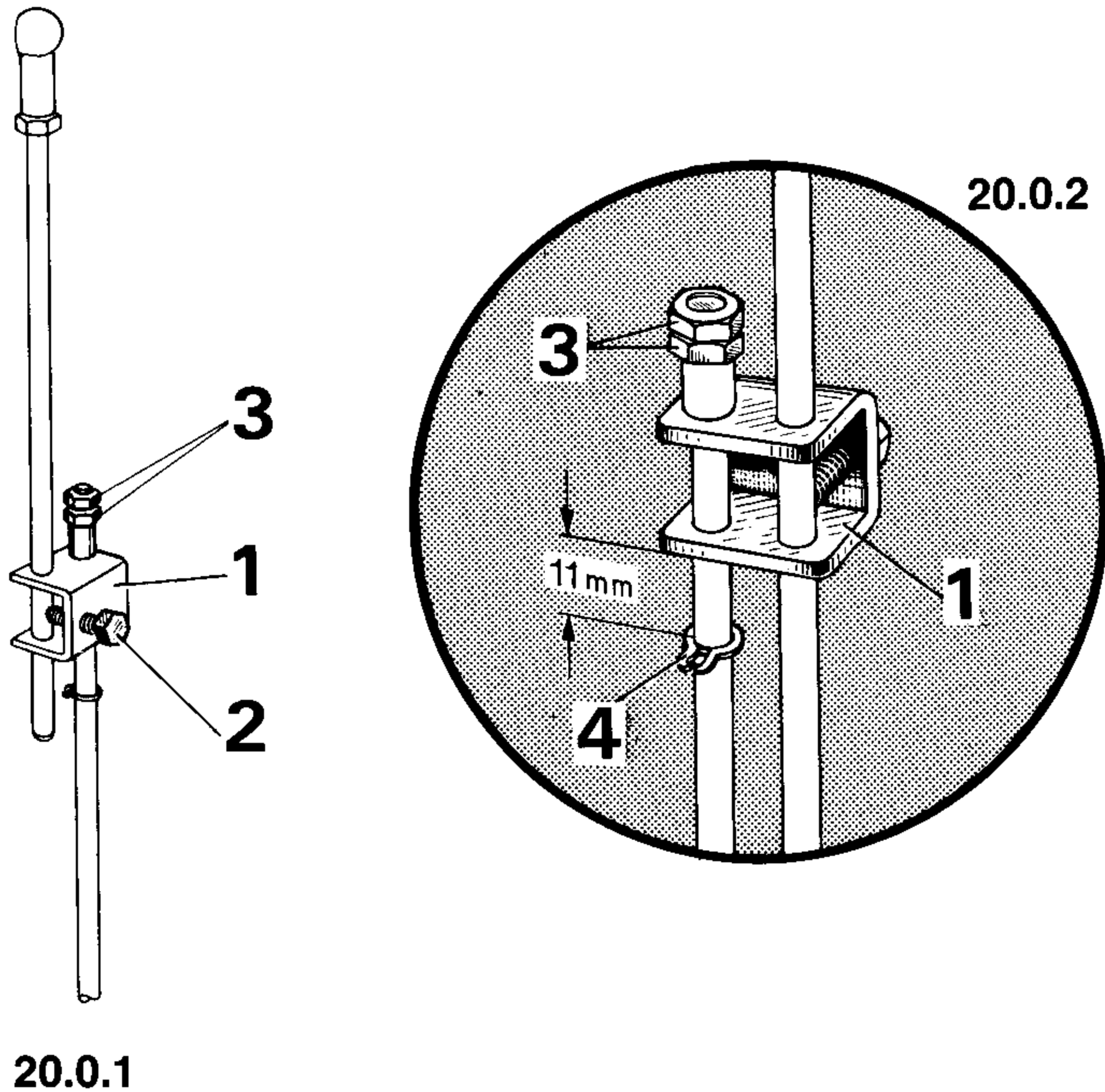
When the pedal is at rest, there should be a clearance of **11 mm** between the bottom edge of connecting clamp **1** and snap ring **4**.

- 20.1 Loosen screw **2** on connecting clamp **1** on the two-part motor connecting rod.
- 20.2 Place the pedal in the position which is most convenient for the operator.
- 20.3 In this position, tighten screw **2** securely.
- 20.4 Loosen both locknuts **3**.
- 20.5 **Turn the bottom nut **3** until there is a clearance of 11 mm between the bottom edge of connecting clamp **1** and snap ring **4** when the pedal is at rest.**
- 20.6 In this position, lock the bottom nut by tightening the top nut **3** against it.

21 **Motor switch lever rocker**  
(on machines equipped with lever-operated Quick-Stop motor)

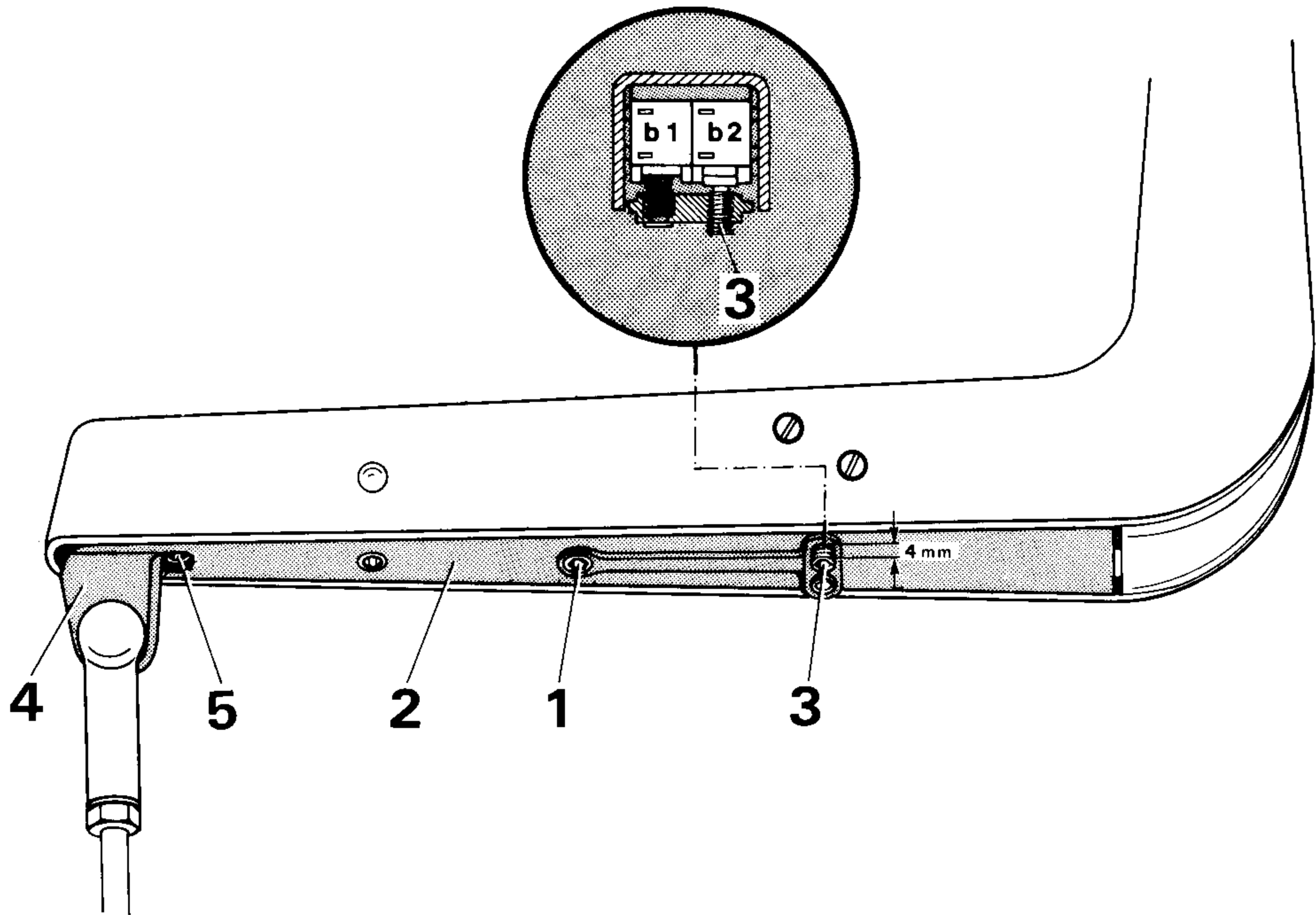

**21.0.1**

- 21.1 Pull the plug of the motor switch lever out of the socket of the motor control panel.
- 21.2 Turn out screw **1** until it protrudes from the surface of rocker **2** by abt. **2 mm**.
- 21.3 Also turn out adjusting screw **3** until its head protrudes from the top surface of the rocker by abt. **4 mm**.
- 21.4 Press connecting rod **4** upwards and turn in adjusting screw **5** as far as it will go.
- 21.5 If you are using a circuit tester, connect the leads to pins **4** and **6** of the six-pin plug. The circuit tester should now indicate flow of current.
- 21.6 Turn adjusting screw **5** back out again until you hear micro switch "b1" click as it switches over. The circuit tester should now indicate **no** flow of current.

- 21.7 Turn adjusting screw **5** out by another quarter of a turn.
- 21.8 Connect the circuit tester leads to pins **1** and **2**. The circuit tester must now indicate flow of current.
- 21.9 Turn in adjusting screw **3** until you hear micro switch "b2" click as it switches over. The circuit tester must now indicate that the current is **cut off**.
- 21.10 Turn adjusting screw **3** back out again until you hear the micro switch click as it switches over again.
- 21.11 Turn out adjusting screw **3** by another quarter of a turn.
- 21.12 Depress the rocker as far as it will go on the side where the lead is fed through to the switch lever.
- 21.13 In this position, turn in screw **1** until it begins to lift the rocker.
- 21.14 On two-needle machines, connect the circuit tester leads to pins **4** and **6** of the six-pin plug.
- 21.15 Turn in adjusting screw **5** until you hear micro switch "b1" click as it switches over. The circuit tester must now indicate flow of current.
- 21.16 Turn adjusting screw **5** out a quarter of a turn again. This prevents repetition of the trimming action if the pedal is heeled a second time by mistake.
- 21.17 Finally push the special four-pin and six-pin plugs into their respective sockets on the motor control panel.

# Contents

	Page
1 Tension release trip . . . . .	1
2 Solenoid bracket . . . . .	2
3 Engaging lever pin . . . . .	3
4 Control cam . . . . .	4
5 Engaging solenoid . . . . .	6
6 Catcher control lever . . . . .	7
7 Micro switches . . . . .	8
8 Catcher actuating lever . . . . .	9
9 Catcher actuating connection (two-needle machines) . . . . .	10
10 Knife carrier . . . . .	11
11 Thread catcher rest position . . . . .	12
12 Catcher support . . . . .	13
13 Knife . . . . .	14
14 Thread nipper spring . . . . .	15
15 Knife-to-thread-catcher adjustment (trimming test) . . . . .	16
16 Tension release . . . . .	17
17 Final adjustment of control cam . . . . .	18
18 Preliminary adjustment of synchronizer . . . . .	19
19 Micro switches "b3" and "b5" . . . . .	23
20 Motor connecting rod . . . . .	25
21 Motor switch lever rocker . . . . .	26
22 Final adjustment of synchronizer . . . . .	28



