

PFAFF® **563;**
563 H

Service Manual

**Pfaff, D 6750 Kaiserslautern, Postfach 3020/3040, Telefon (06 31) 200-0, Telex 45 753
Telefax (06 31) 172 02**

Instructions for adjusting the Pfaff 563; 563 H

Notes on safety:

The machine must only be used for the purpose it has been designed for.

When converting it into another version, all valid safety rules must be followed.

Maintenance- and repair work must only be carried out by personnel instructed accordingly.

Apart from permissible deviations according to DIN 57 105 and VDE 0105, work on live parts is not permitted.

Important note

On machines which are put into operation for the first time or which have been idle for a longer period of time (1 or 2 months), make absolutely sure to check the hook lubrication system (Section 14). For topping up we recommend using Pfaff sewing machine oil No. 280-1-120144 with a mean viscosity of 22 mm²/s at 40°C and a density of 0.865 g/cm³.

This service manual applies to both the Pfaff 563 and 563 H with hinged presser foot as well as with roller presser.

Instructions for deviating adjustments are given in the respective sections.

Tools, gauges and other equipment for adjustment:

Set of screwdrivers with blades from 2 to 10 mm wide

Set of allen keys ranging from 1.5 to 6.0 mm

Set of open-ended spanners/wrenches from 7 to 14 mm wide

Metal rule

C-clamp (No. 08-880137-00)

Gauge (No. 08-880179-00 or No. 61-111642-19)

Pack of needles

Strips of white paper, sewing thread and material for test sewing

1 Zeroing the feed motion

Setting:

With the stitch length control set at "0" the feed dog must not move when the balance wheel is turned.

1.1 Adjustment procedure with gearcase closed.

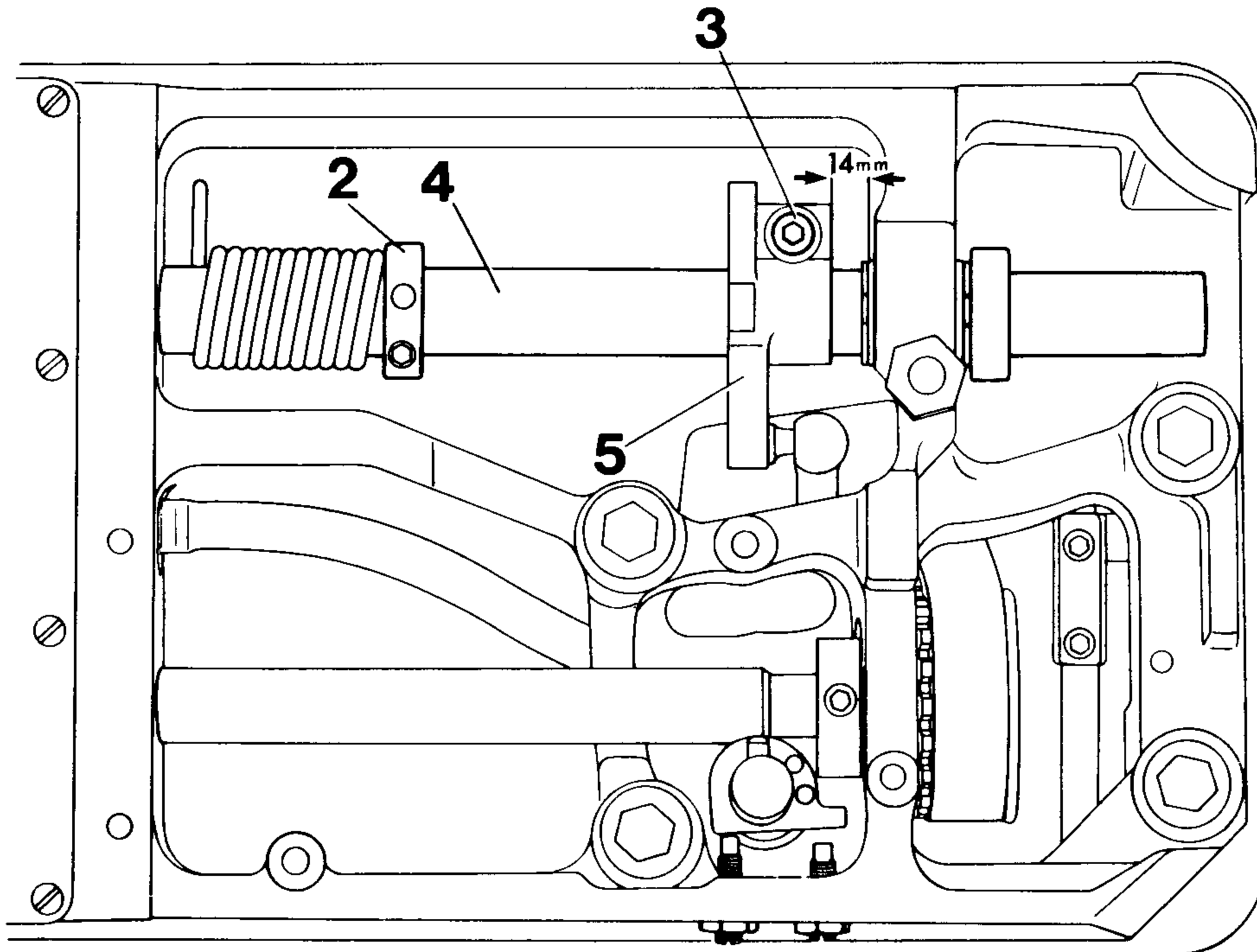

1.0.1

Adjustment:

- 1.1.1 Remove needle from needle holder.
- 1.1.2 Remove knee lever.
- 1.1.3 Raise presser foot/roller presser and turn stitch length control to "0".
- 1.1.4 Insert an allen key or a pin in tension ring 2 and hold feed regulator shaft 4 fast with it.
- 1.1.5 **Loosen screw 3 and, while rotating the balance wheel, turn feed regulator shaft 4 with the aid of the allen key until the feed dog no longer moves.**
- 1.1.6 In this position, hold the allen key fast and tighten screw 3, making sure there is a clearance of 14 mm between crank 5 and the bearing bush.
- 1.1.7 Check this adjustment (see "Setting").

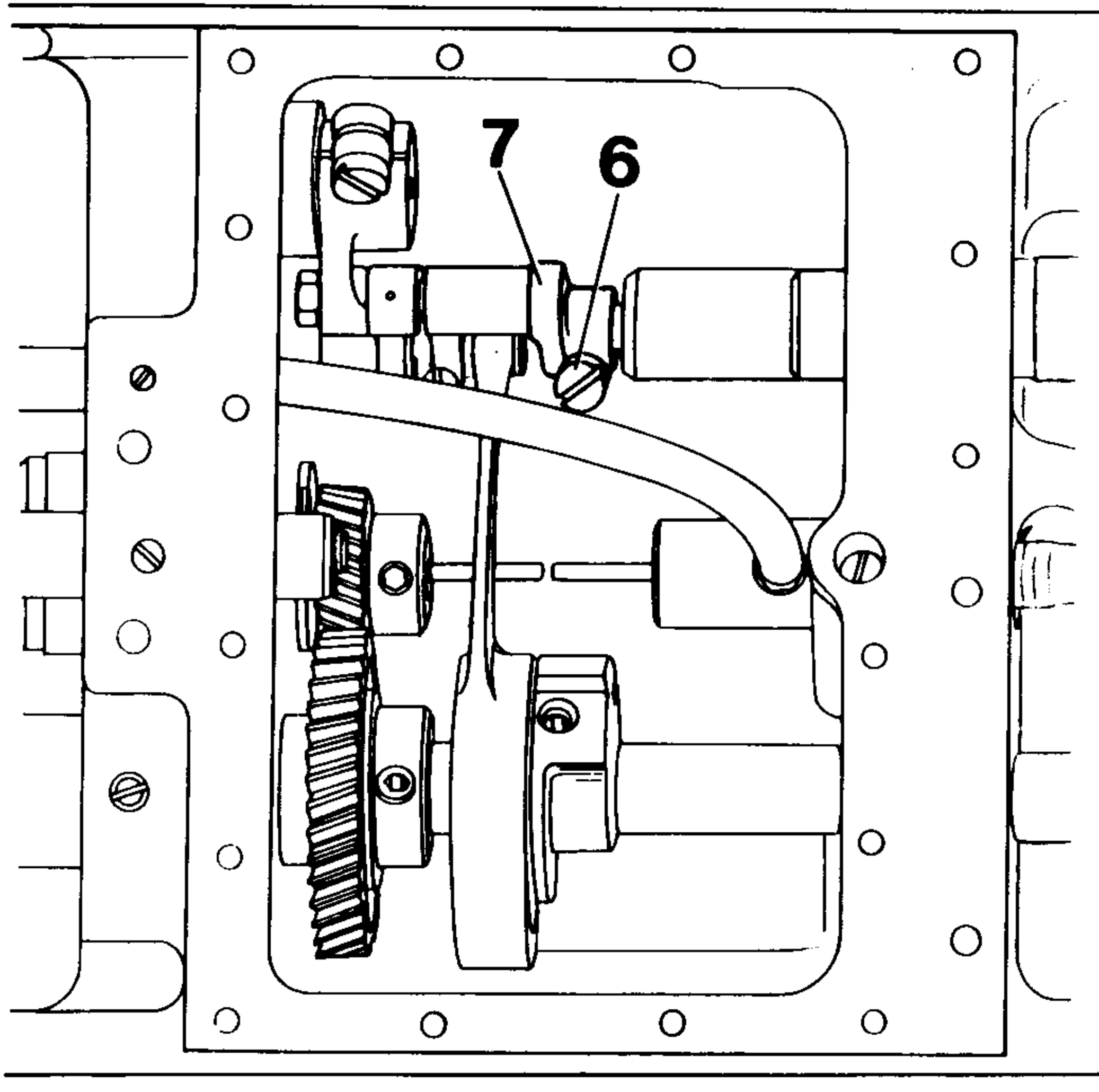
**1.0.2****Adjustment:**

- 1.2.1 Remove needle from needle holder, remove the knee lever and raise the presser foot/roller presser.
- 1.2.2 Take out the screws of the gearcase cover and remove the cover with its gasket, making sure that the oil, if any, is drained off into a container.
- 1.2.3 Take the oil sponge out of the gearcase.
- 1.2.4 Turn the stitch length control to "0".
- 1.2.5 Loosen screw 6 just sufficiently to allow crank 7 to be turned on its shaft against resistance.
- 1.2.6 **Adjust crank 7 while rotating the balance wheel until the feed dog no longer moves.**
- 1.2.7 In this position, tighten screw 6.
- 1.2.8 Check this adjustment (see "Setting").

2 Feed lifting motion

Setting:

With the stitch length control set at "0" and the needle bar positioned at top dead center (t.d.c.), the feed dog must be at its highest point. In this position, the notch in feed lifting eccentric 2 must be positioned perpendicularly below the center of the shaft (Fig. 2.0.2).

Note:

On machines equipped with roller presser (subcl. -944/01), the following adjustment is made with the needle bar positioned 0.6 mm past t.d.c.

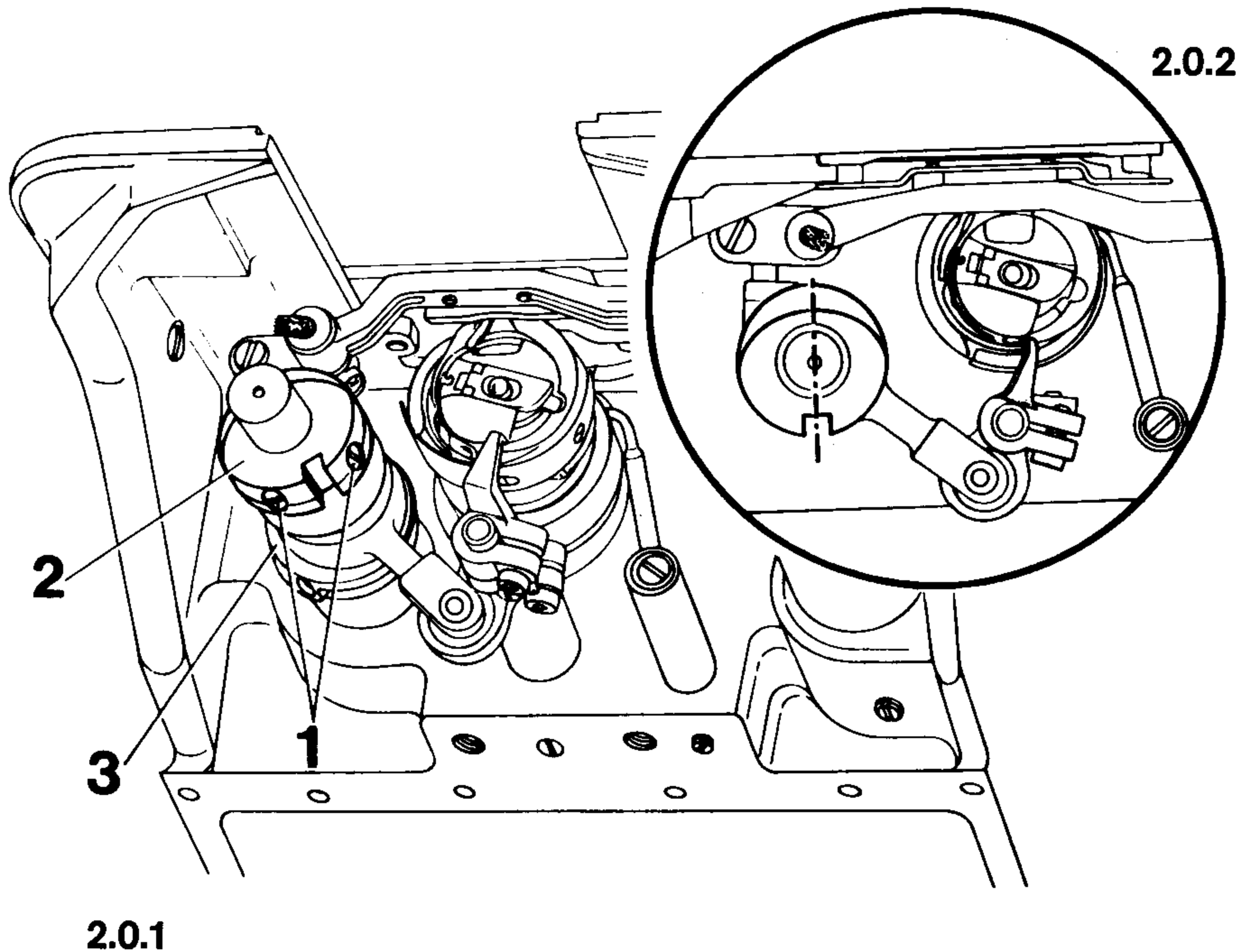

Adjustment:

- 2.1 Turn the stitch length control to "0".
- 2.2 Loosen the two screws 1.
- 2.3 Set the needle bar at t.d.c. (or 0.6 mm past t.d.c. on machines with roller presser).
- 2.4 **In this position, turn feed lifting eccentric 2 until the feed dog is at its highest point.** The notch in feed lifting eccentric 2 is now positioned perpendicularly below the center of the shaft (and almost perpendicularly on machines with roller presser).
- 2.5 In this position, tighten both screws 1, making sure there is a small amount of play between feed lifting eccentric 2 and bobbin case opener eccentric 3.
- 2.6 Check this adjustment (see "Setting").

3 Feed dog height

Setting:

With the stitch length control set at "0", the feed dog, when at its highest point, must be positioned in the middle of its slots and contact the gauge throughout its length (Fig. 3.0.2).

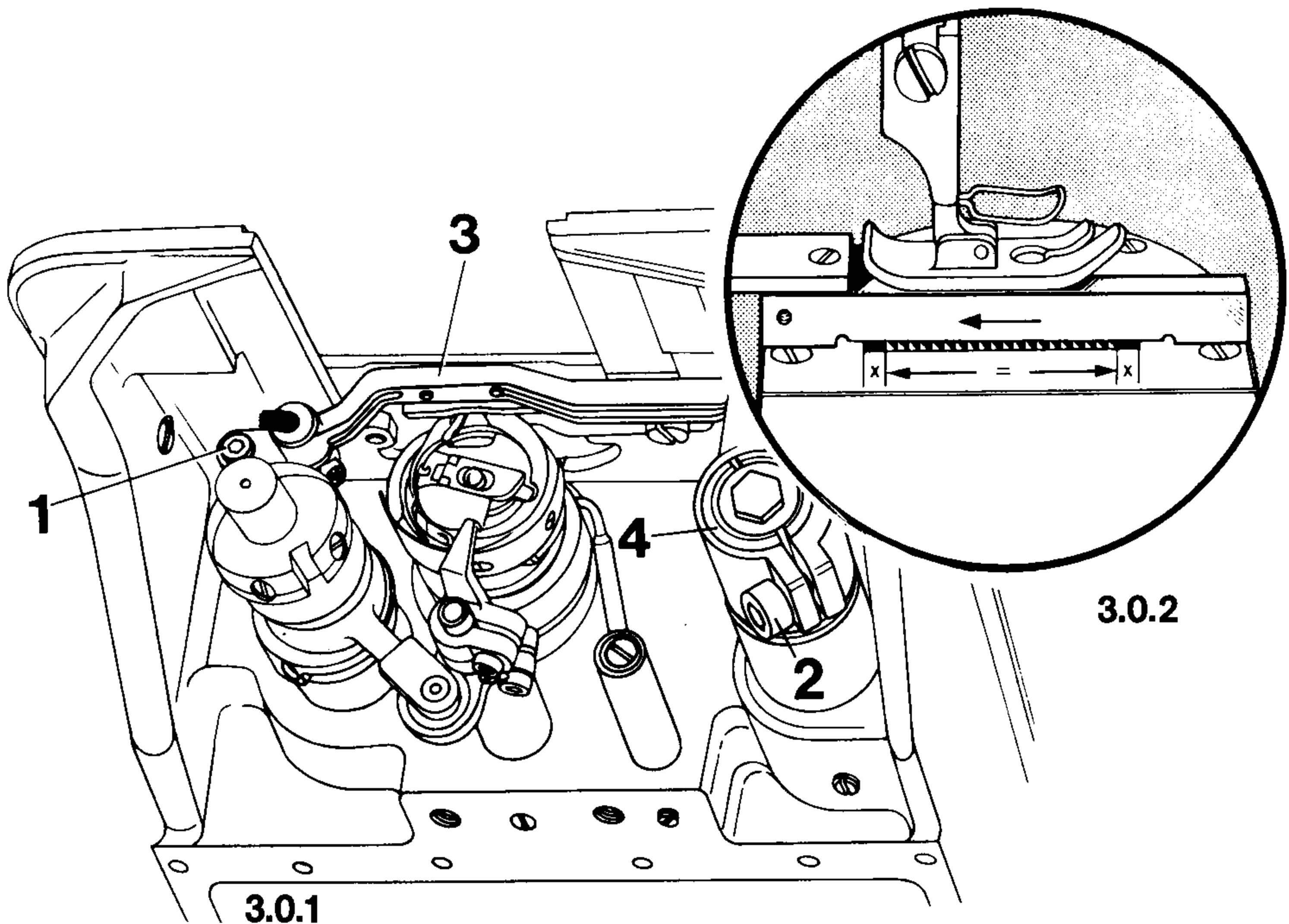

Adjustment:

- 3.1 Check to make sure the stitch length control is set at "0" and turn the balance wheel until the feed dog is at its highest point.
- 3.2 Loosen screws 1 and 2.
- 3.3 Place the gauge under the presser foot so that its front edge is flush with the front edge of the needle plate and the arrow on the gauge points in the direction of feed.
- 3.4 Lower the presser bar lifter to rest the presser foot/roller presser on the gauge.
- 3.5 Position the feed dog in the middle of its slots (Fig. 3.0.2) and tighten screw 2 just lightly.
- 3.6 Push feed bar 3 upwards until the feed dog contacts the gauge and tighten screw 1 lightly.
- 3.7 **Turn eccentric bushing 4 until the feed dog is in contact with the gauge throughout its entire length.**
- 3.8 In this position, tighten screws 1 and 2, making sure the feed dog is centered in its slots both sideways and lengthwise.
- 3.9 Check this adjustment (see "Setting").
- 3.10 Raise the presser bar lifter and remove the gauge from under the presser foot/roller presser.

4 Feed driving motion

Setting:

With the machine set for its longest stitch and the needle bar positioned 0.6 mm past top dead center (t.d.c.) the feed dog must not move when the reverse-feed control is operated.

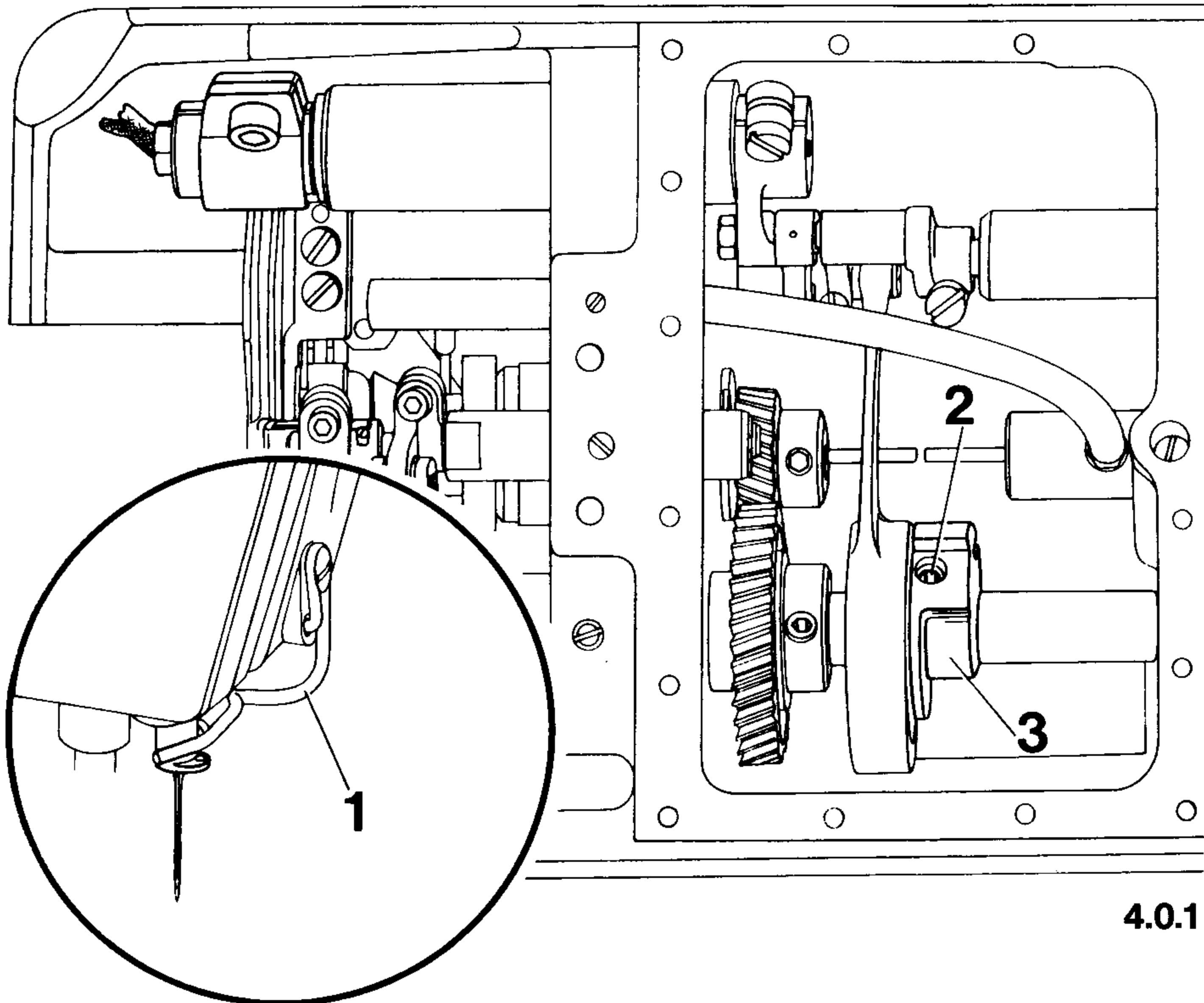

4.0.2

4.0.1

Adjustment:

- 4.1 Set the machine for its longest stitch.
- 4.2 Unscrew thread guide 1.
- 4.3 Loosen the two screws 2 just sufficiently to allow feed eccentric 3 to be turned on its shaft against resistance.
- 4.4 Turn the balance wheel to set the needle bar at 0.6 mm past t.d.c.
- 4.5 **In this position, moving the reverse-feed control up and down, turn feed eccentric 3 until the feed dog is completely motionless.**
- 4.6 In this position, tighten screws 2, making sure that the connecting rod of feed eccentric 3 is at right angles to the feed rock shaft.
- 4.7 Check this adjustment (see "Setting").

5 Centering the needle in the needle hole

Setting:

A straight needle must be positioned in the middle of the needle hole (Fig. 5.0.2).

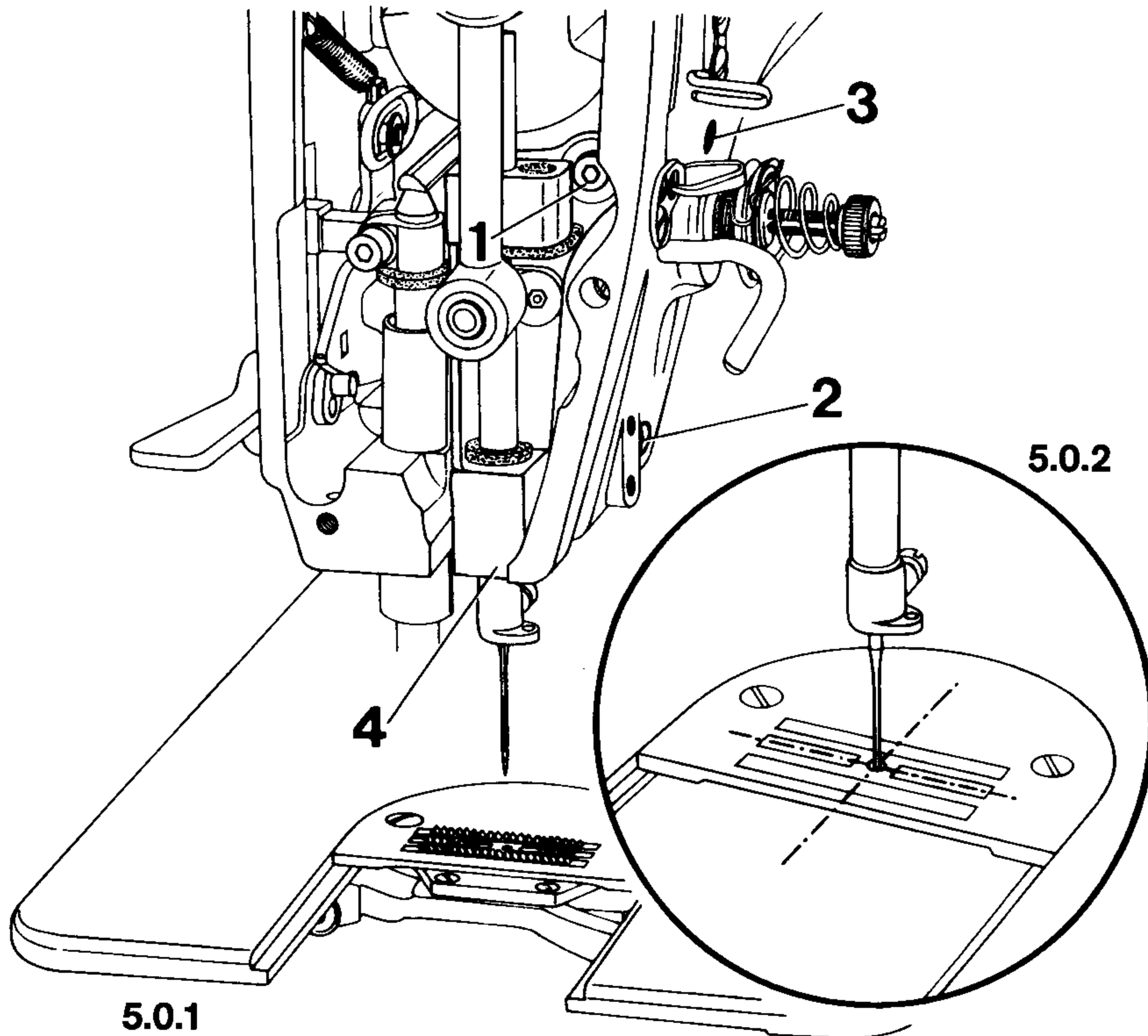

Adjustment:

- 5.1 Bring the needle bar to t.d.c.
- 5.2 Remove presser foot and face plate.
- 5.3 Insert a new needle into the needle holder.
- 5.4 Loosen screws 1, 2 and 3.
- 5.5 Turn the balance wheel until the needle is positioned above the needle hole.
- 5.6 **Adjust the position of needle bar frame 4 sideways and lengthwise until the needle is centered in the needle hole.**
- 5.7 In this position, tighten screw 2 securely, and screw 3 just lightly.
- 5.8 **With screw 1 pull the guide pin behind it toward the lug of the needle bar frame and tighten screw 1.**
- 5.9 To make sure the needle bar frame is not under stress, loosen screw 3, turn the balance wheel a few turns, then tighten screw 3 securely again.
- 5.10 Check this adjustment (see "Setting").

Setting:

With the needle bar at bottom dead center (b.d.c.) there must be a clearance of approx. **16.5 mm** between needle holder and needle plate.

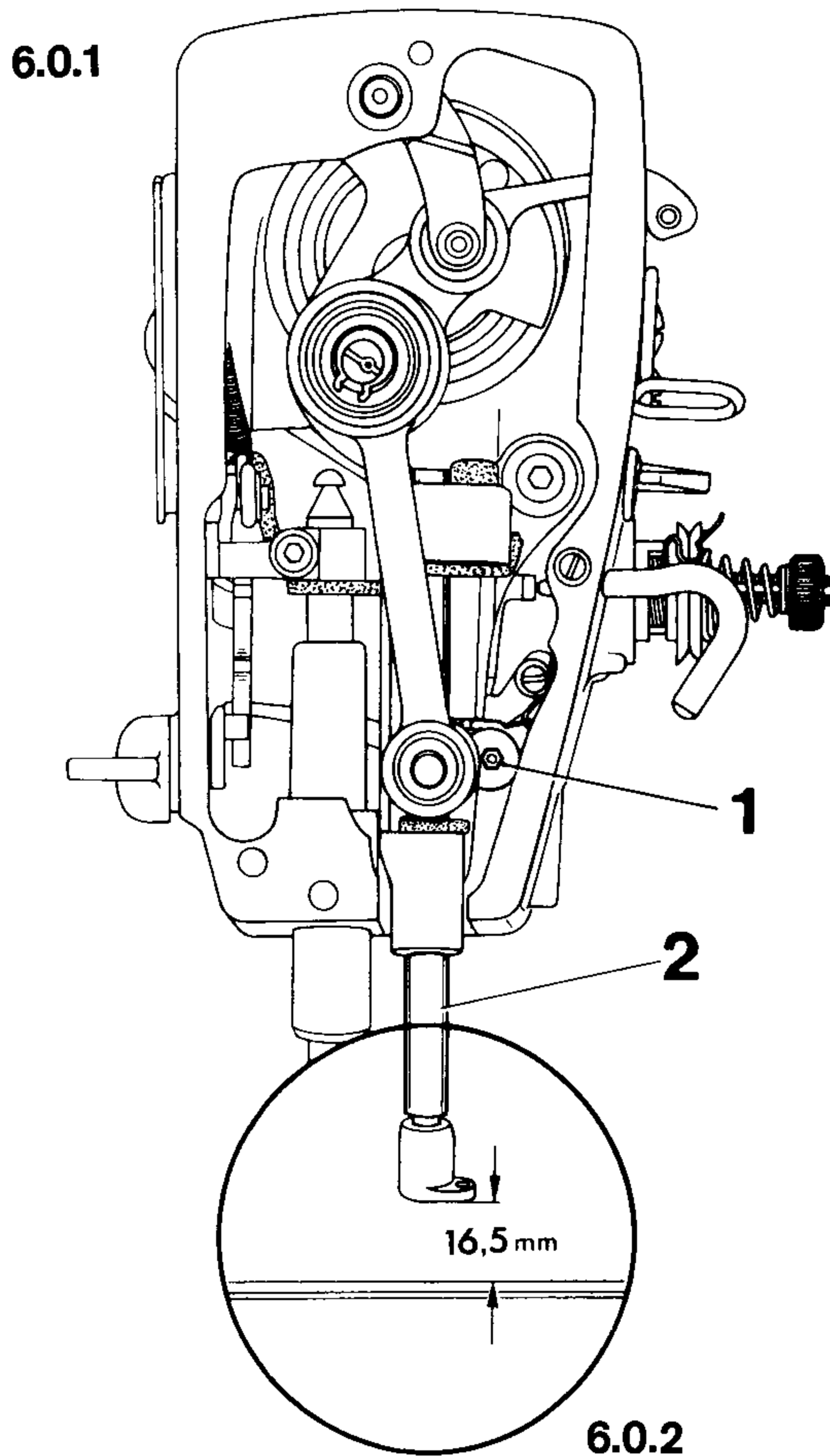

Adjustment:

- 6.1 Loosen screw 1.
- 6.2 Turn the balance wheel to bring the needle bar to b.d.c., making sure the needle does not hit the sewing hook.
- 6.3 **Adjust needle bar 2 vertically until there is a clearance of approx. 16.5 mm between needle holder and needle plate.**
- 6.4 In this position, tighten screw 1, making sure the needle set screw points toward the right (as seen in the direction of feed).

*) For final adjustment see Section 8.

7 Eccentric hook shaft bearing

Setting:

There must be a clearance of 0.3 mm between the hook point and the middle of the clearance cut of the needle when the sewing hook is up against oil thrower 3 (Fig. 7.0.2). Also there must be a minimum amount of play between the gears.

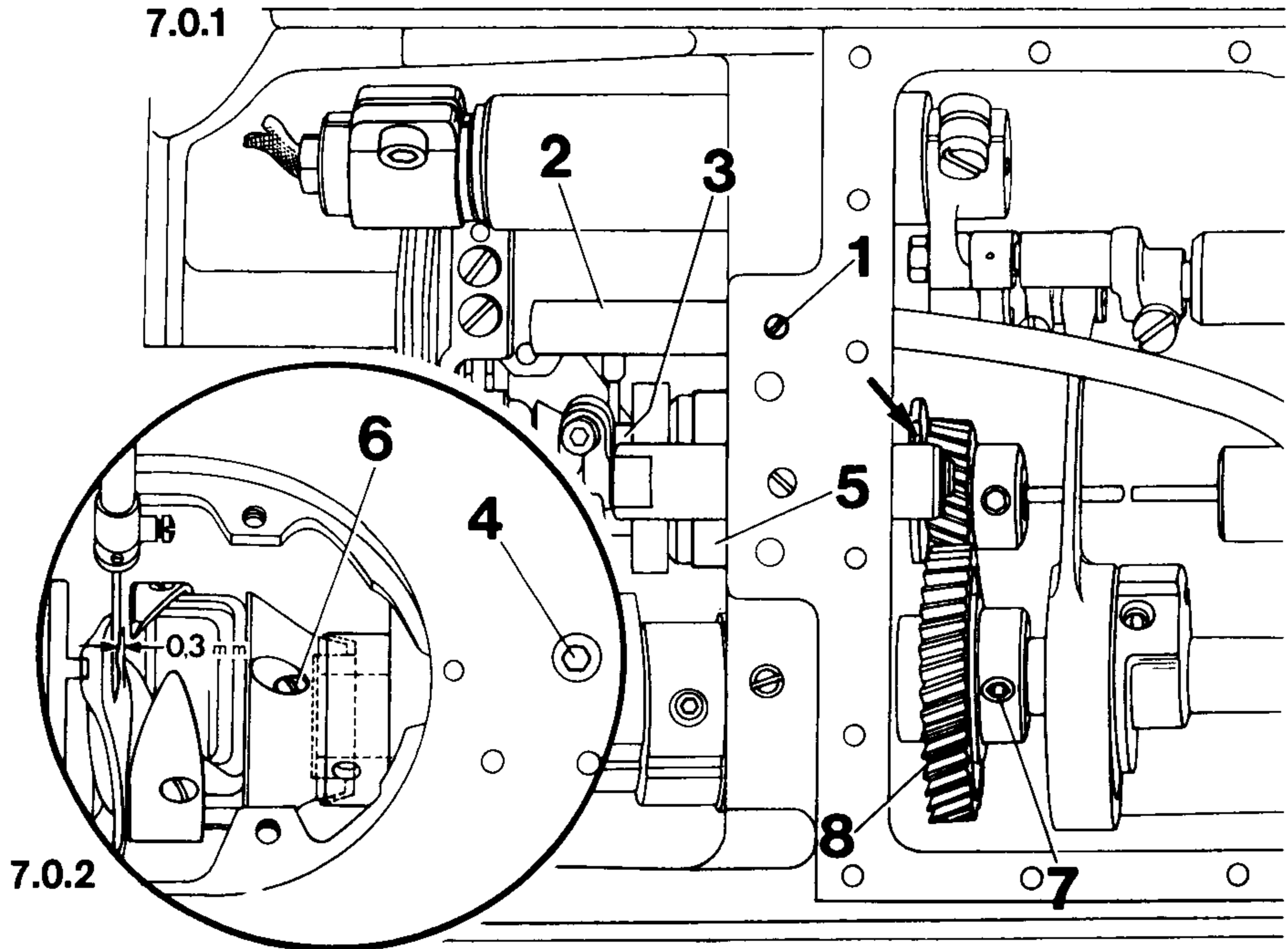

Adjustment:

- 7.1 Remove needle plate and feed dog.
- 7.2 Loosen screw 1 and swivel the oil tube out of oil thrower 3.
- 7.3 Loosen screw 4.
- 7.4 **Turn the eccentric hook shaft bearing 5 so that its recess (see arrow in Fig. 7.0.1) is visible from below and the two gears neither have too much play nor stand too close together.**
- 7.5 Loosen both screws 6.
- 7.6 Push the sewing hook up against oil thrower 3.
- 7.7 Turn the sewing hook and reposition the needle bar until the hook point is positioned in the middle of the clearance cut of the needle.
- 7.8 **Reposition hook shaft bearing 5 until there is a clearance of 0.3 mm between the hook point and the middle of the clearance cut of the needle, making sure however that the bearing is not turned and the hook remains in contact with oil thrower 3.**
- 7.9 In this position, tighten screw 4 securely, making sure the gears have the correct amount of play.
- 7.10 Loosen both screws 7.
- 7.11 Reposition gear 8 on its shaft until it is exactly in line with the pinion.
- 7.12 Tighten screws 7 securely.
- 7.13 Do not tighten screws 6 as yet and leave the oil tube swivelled away for the following adjustment.

Setting:

When the needle bar is positioned 1.8 mm past b.d.c. the top edge of the needle eye must be positioned **0.8 mm** below the bottom edge of the hook point (Fig. 8.0.3). In this position, there must be a clearance of not more than **0.1 mm** between hook point and needle (Fig. 8.0.2).

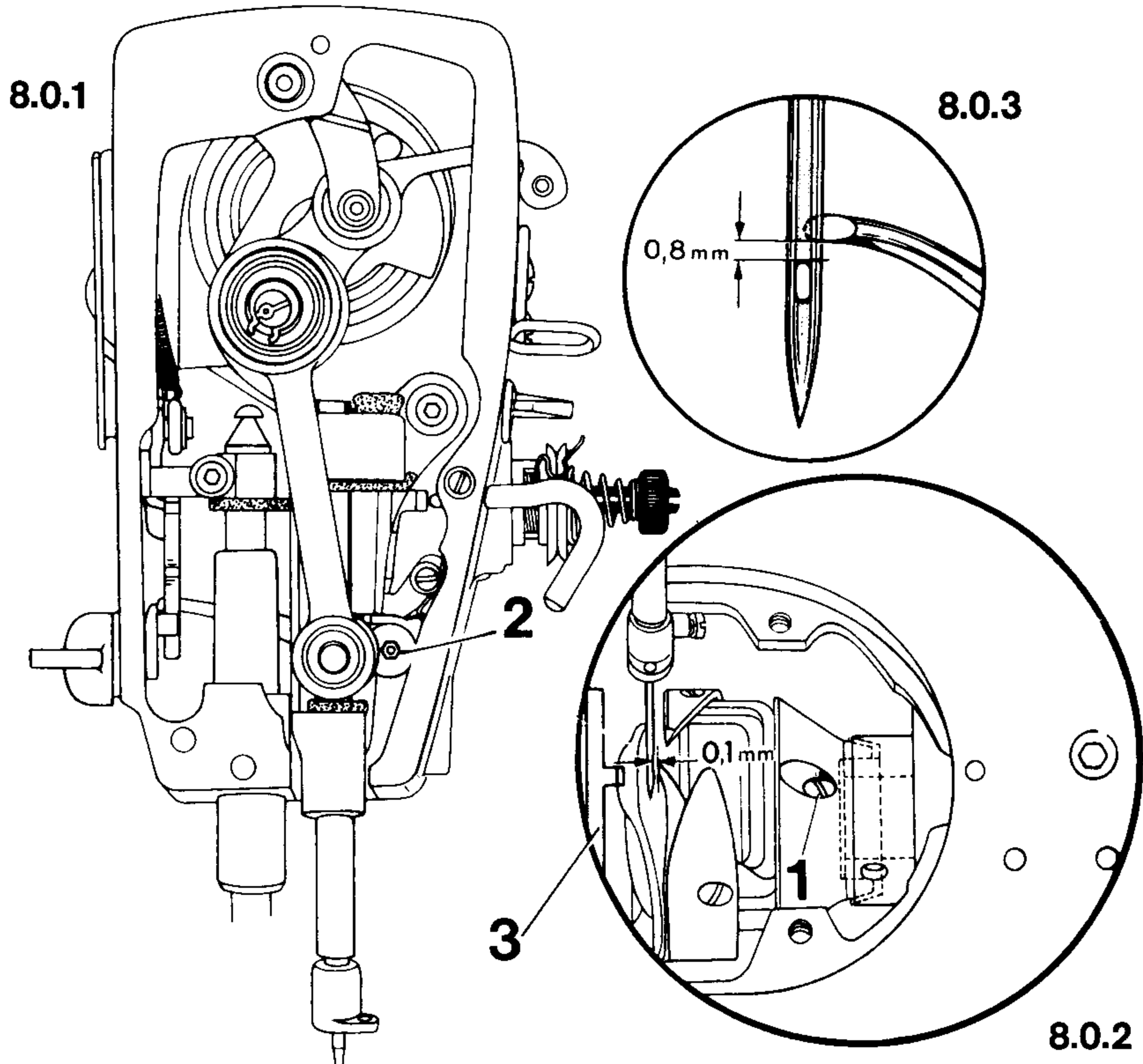

Adjustment:

- 8.1 Set the needle bar at b.d.c., making sure the two screws 1 are loose and the needle does not strike the sewing hook.
- 8.2 Push the 1.8-mm-thick gauge blade with its cutout onto the needle bar immediately below its lower bushing.
- 8.3 Push the C-clamp onto the needle bar below the gauge, push it up against the gauge and tighten its screw.
- 8.4 Pull out the gauge blade and turn the balance wheel in its normal direction of rotation until the C-clamp contacts the lower needle bar bushing.
- 8.5 **Check to make sure the top edge of the needle eye is positioned 0.8 mm below the bottom edge of the hook point.**
- 8.6 **If adjustment is required, loosen screw 2 and move the needle bar up or down as appropriate, however without turning it, and tighten screw 2 again.**
- 8.7 **Adjust the sewing hook laterally until there is a clearance of not more than 0.1 mm between its point and the needle when the hook is positioned opposite the center line of the needle.**
- 8.8 In this position, tighten the accessible screw 1, making sure position finger 3 is in the slot of the bobbin case.
- 8.9 Remove the C-clamp from the needle bar.
- 8.10 Tighten the second screw 1.
- 8.11 Check this adjustment (see "Setting").

Setting:

At the left point of reversal of bobbin case opener finger 2, the finger and the lug of bobbin case base 4 must be at the same height.

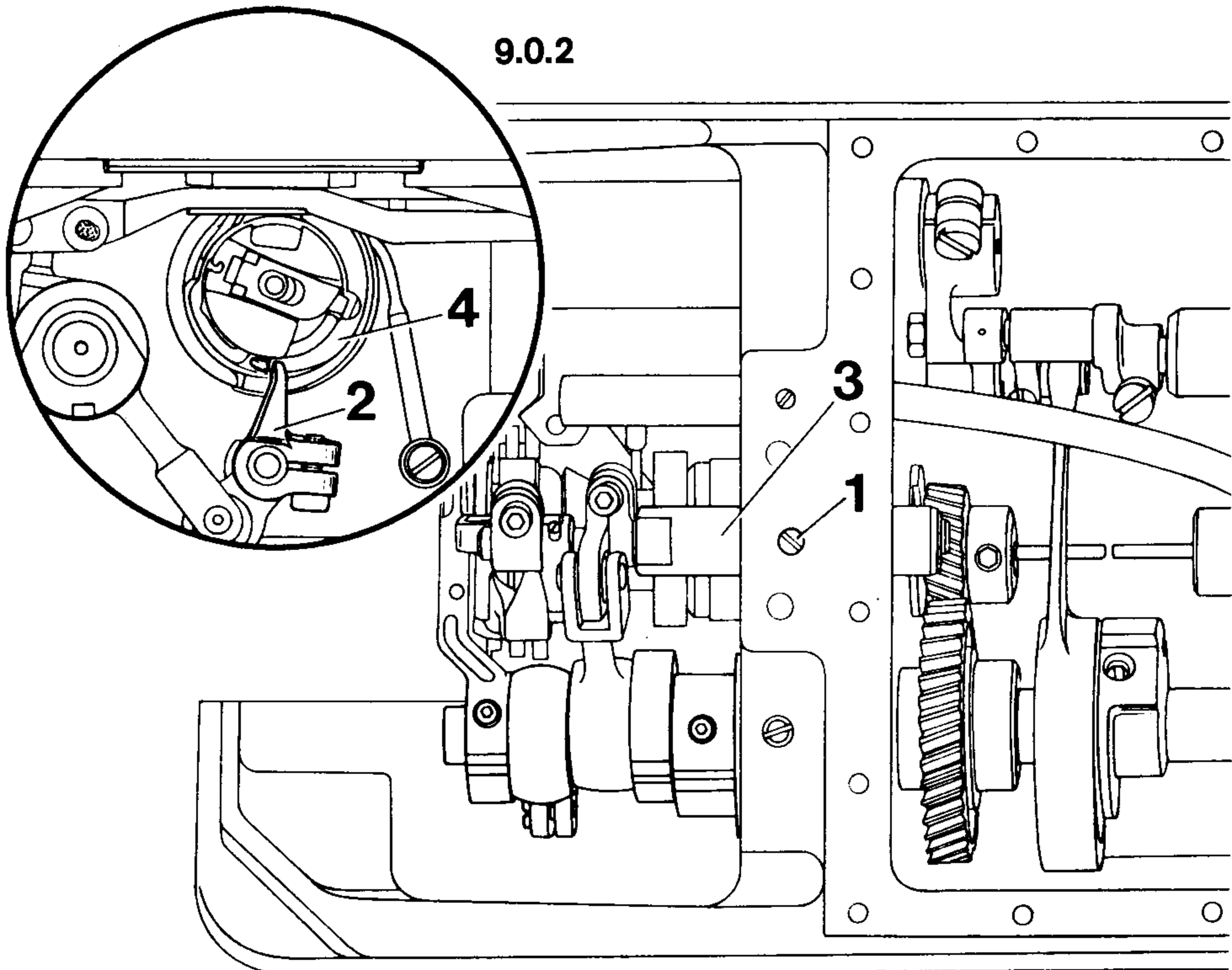

9.0.1

Adjustment:

- 9.1 Loosen screw 1.
- 9.2 Turn the balance wheel to set opener finger 2 at its left point of reversal.
- 9.3 **Turn eccentric bushing 3 until opener finger 2 and the lug of bobbin case base 4 are at the same height.** (Make sure the bobbin case can be easily removed from the sewing hook.)
- 9.4 In this position, tighten screw 1.
- 9.5 Check this adjustment (see "Setting").

Setting:

There must be a clearance of 0.8 mm between bobbin case opener finger 3 and bobbin case base 4 (Fig. 10.0.2). When opener finger 3 is at its left point of reversal, there must be a clearance of approx. 0.3 mm between bobbin case base 4 and position finger 5 (Fig. 10.0.3). In this position, screw 1 must contact stop pin 7 (Fig. 10.0.4).

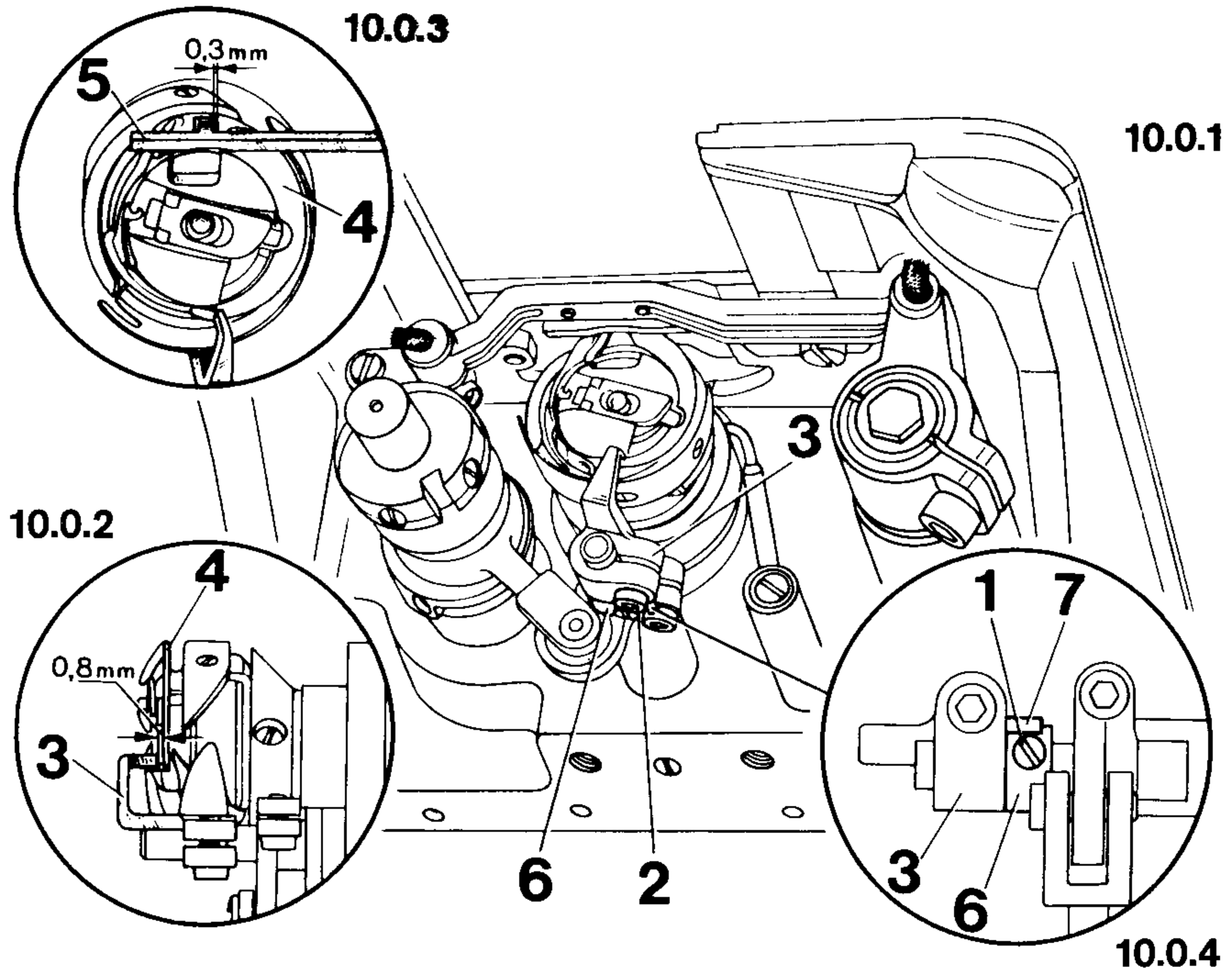

Adjustment:

- 10.1 Loosen screw 1.
- 10.2 Loosen clamp screw 2 of opener finger 3 just sufficiently to allow it to be turned on its shaft against resistance.
- 10.3 **Reposition opener finger 3 on its shaft until there is a clearance of approx. 0.8 mm between it and bobbin case base 4.**
- 10.4 Rotate the balance wheel until opener finger 3 is at its left point of reversal.
- 10.5 **Turn opener finger 3 until there is a clearance of approx. 0.3 mm between position finger 5 and the right wall of the position slot in bobbin case base 4 when opener finger 3 contacts the lug of bobbin case base 4.**
- 10.6 In this position, tighten clamp screw 2.
- 10.7 Push collar 6 up against opener finger 3 and turn it so that screw 1 contacts stop pin 7.
- 10.8 In this position, tighten screw 1.
- 10.9 Check this adjustment (see "Setting").

11 Timing the bobbin case opener

Setting:

When the needle bar is positioned 1.8 mm past b.d.c. opener finger 2 must be at its right point of reversal.

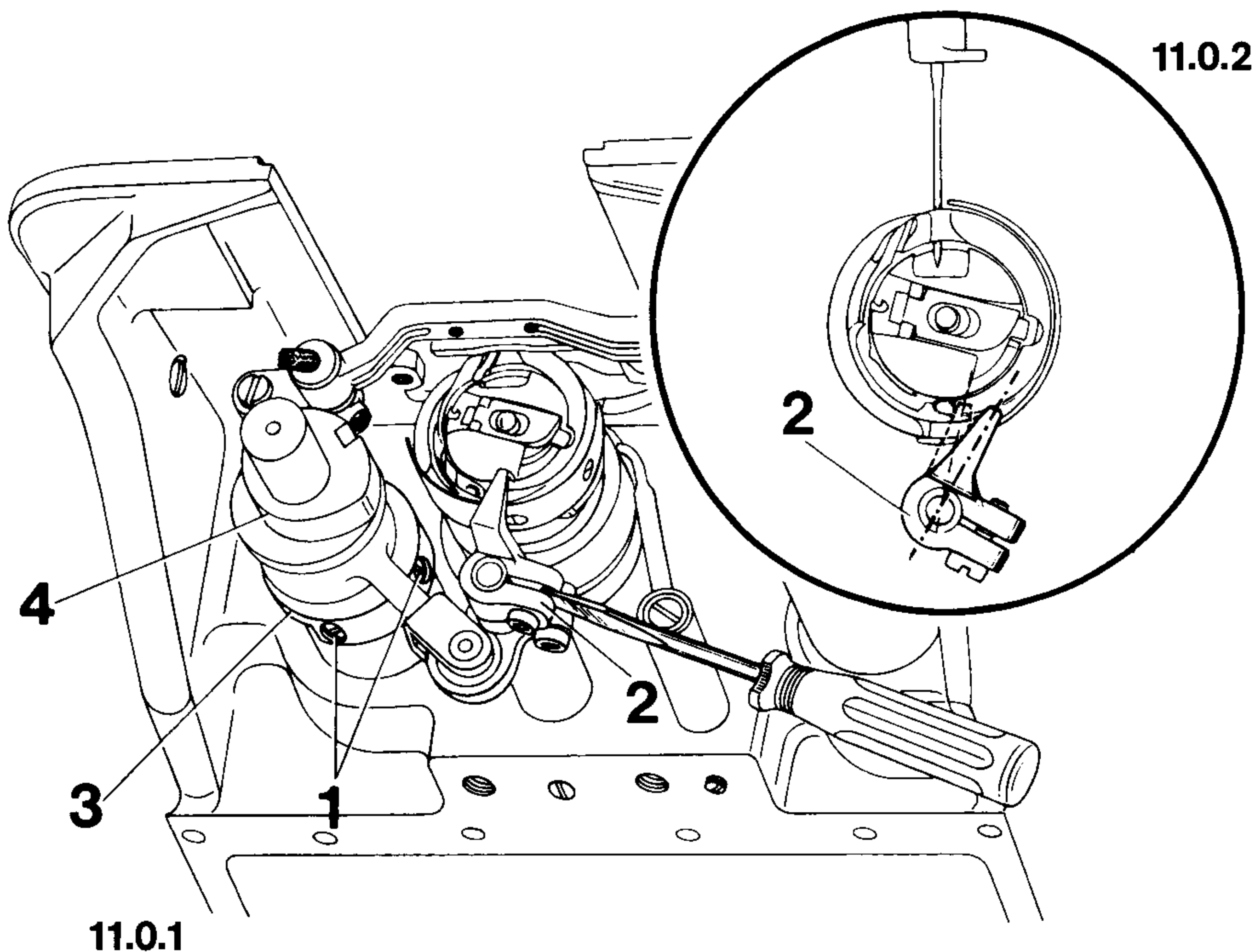

Adjustment:

- 11.1 Loosen both screws 1.
- 11.2 Turn the balance wheel until the needle bar is at b.d.c.
- 11.3 Push the 1.8-mm-thick gauge blade with its cutout onto the needle bar immediately below its lower bushing.
- 11.4 Push the C-clamp onto the needle bar below the gauge, push it up against the gauge and tighten its screw.
- 11.5 Pull out the gauge blade and turn the balance wheel in its normal direction of rotation until the C-clamp contacts the lower needle bar bushing.
- 11.6 To facilitate adjustment, insert a small screwdriver in the slot of the clamp of opener finger 2.
- 11.7 **Turn opener eccentric 3 until opener finger 2 is at its right point of reversal.**
- 11.8 In this position, tighten the accessible screw 1, making sure there is a small clearance between eccentrics 3 and 4.
- 11.9 Remove the C-clamp from the needle bar and tighten the second screw 1.
- 11.10 Check this adjustment (see "Setting") and pull the screwdriver out of the clamp slot.

12 Oil tube and oil thrower

Setting:

Oil tube 2 must be positioned in the hole of oil thrower 3 (Fig. 12.0.2).

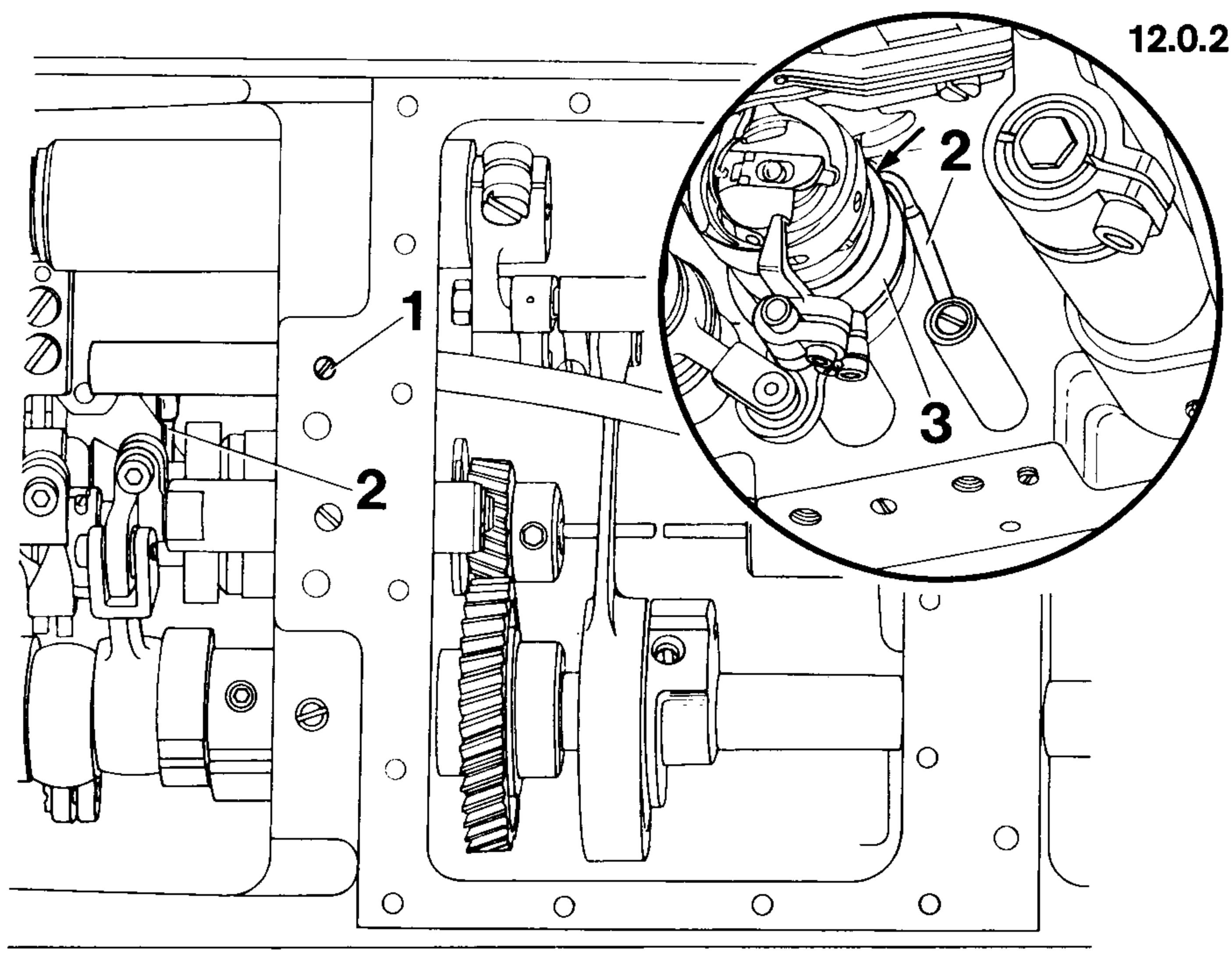

12.0.1

Adjustment:

- 12.1 **Loosen screw 1 and insert oil tube 2 into the hole of oil thrower 3 (see arrow in Fig. 12.0.2). If necessary, turn oil thrower 3 accordingly.**
- 12.1.1 On subcl. -900/.. machines the oil thrower can only be turned after loosening its screws.
- 12.2 Tighten screw 1.
- 12.3 Check this adjustment (see "Setting").

13 Oil check valve

Setting:

There must be a clearance of **1.0 mm** between actuating rod **3** and valve rod **4**.

Note:

On machines which have been in operation for a longer time it is recommended to replace the oil pad (No. 91-171951-05) and fill in approx. 120 c.c. of fresh oil (No. 280-1-120144) before the gearcase is closed.

13.0.1

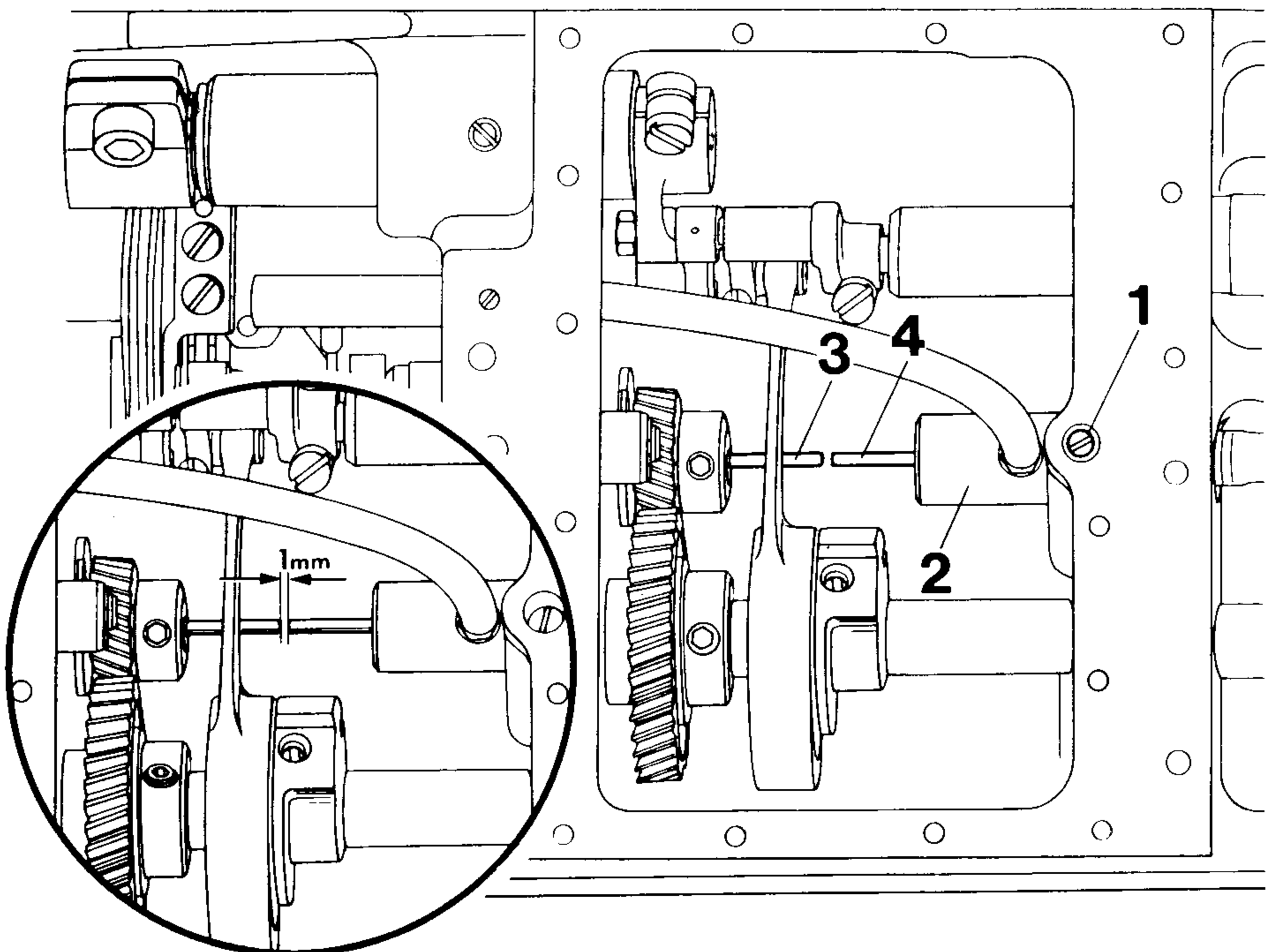

13.0.2

Adjustment:

- 13.1 Loosen screw 1.
- 13.2 Push actuating rod 3 into the centrifugal governor as far as it will go.
- 13.3 Push valve rod 4 into oil check valve 2 until a resistance is felt.
- 13.4 **Reposition oil check valve 2 until there is a clearance of 1.0 mm between actuating rod 3 and valve rod 4.**
- 13.5 In this position, tighten screw 1.
- 13.6 Check this adjustment (see "Setting").
- 13.7 Place the oil pad between oil tube and gears.
- 13.8 Clean the gasket face on the gearcase and the gasket of the gearcase cover.
- 13.9 Replace the gearcase cover and simultaneously screw on the two machine legs, tightening the screws of the cover crosswise.

Setting:

After the machine has run at full speed for about ten seconds, a fine trace of oil must appear on a piece of paper placed over the needle plate cutout above the hook raceway (see arrows in Fig. 14.0.2).

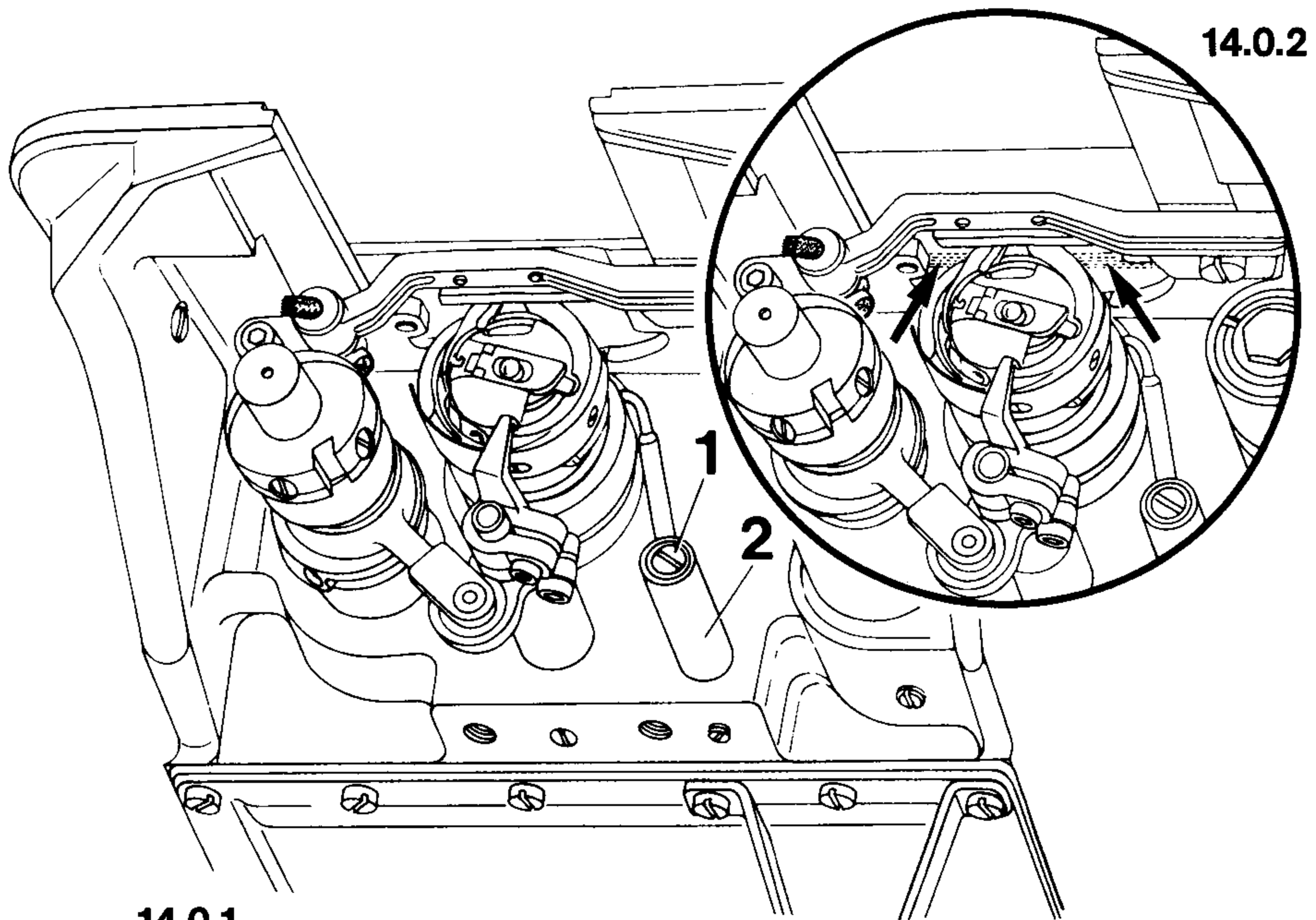

14.0.1

14.0.2

Adjustment:

- 14.1 Check the oil level in the oil sight glass and, if necessary, top up the reservoir until the oil level is in line with the upper mark. Use oil No. 280-1-120144.
- 14.2 Turn in regulating screw 1 of oil regulating valve 2 as far as it will go, and then back about three turns.
- 14.3 Start the machine and run it until the sewing hook starts emitting oil.
- 14.4 Turn regulating screw 1 in completely and then out 1/2 turn.
- 14.5 Let the machine run about 1 minute.
- 14.6 Place a piece of white paper over the needle plate cutout.
- 14.7 **Let the machine run about ten seconds. Then check to see if a fine trace of oil has appeared on the paper opposite the hook raceway (see arrows in fig. 14.0.2).**
- 14.8 If too much oil is emitted, turn regulating screw 1 in a little; or, if too little oil is emitted, turn it out somewhat.
- 14.9 Check this adjustment (see "Setting").

Clearance between presser foot/roller presser and needle plate

Setting:

With presser bar lifter 1 raised, there must be a clearance of 7.0 mm between needle plate and presser foot/roller presser. When the presser foot/roller presser rests on the needle plate, there must be a distance of approx. 10 mm between the presser foot/roller presser mounting and presser bar bushing 6.

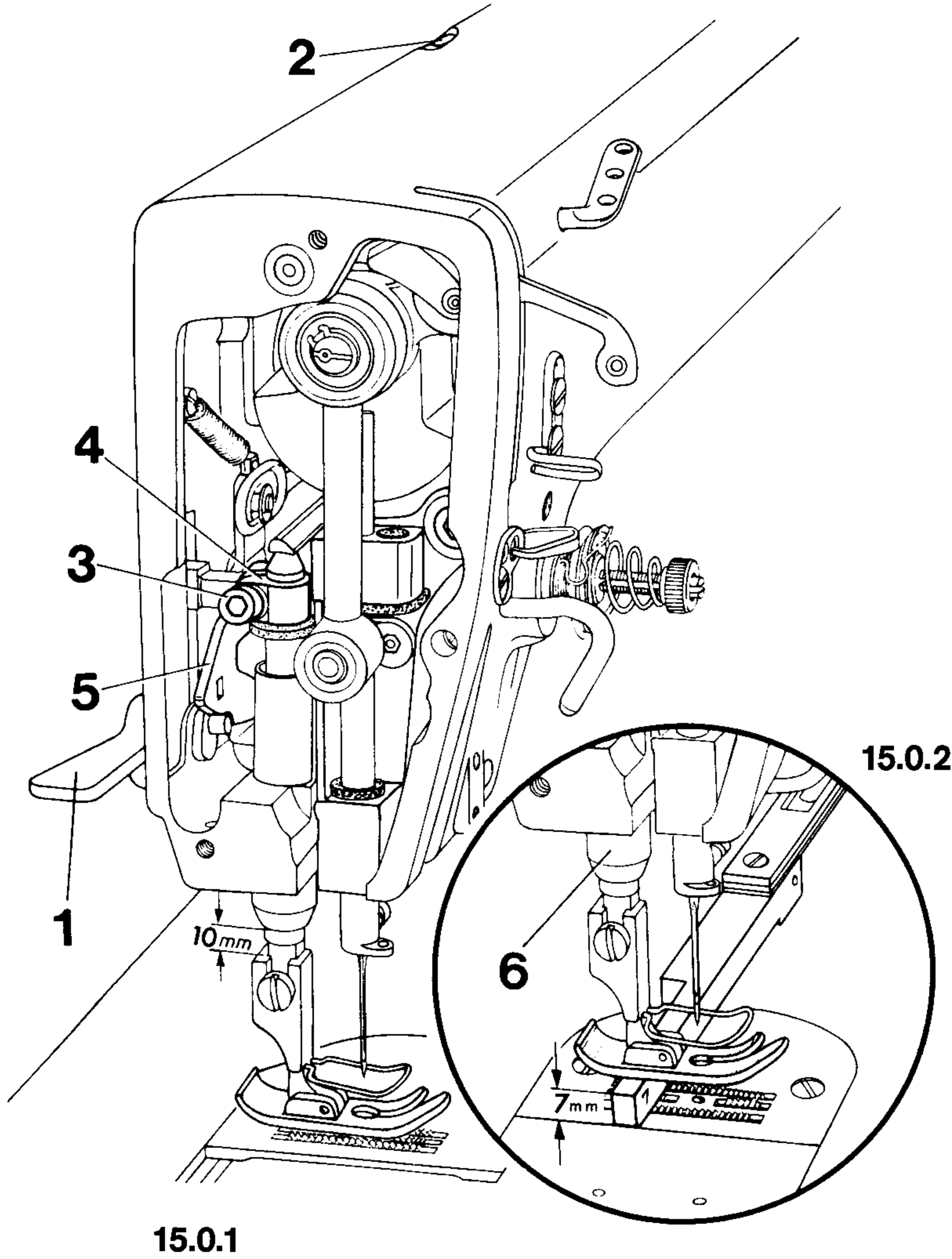

Adjustment:

- 15.1 Screw on feed dog and needle plate, making sure the feed dog moves freely in its slots.
- 15.2 Screw on the presser foot/roller presser and lower presser bar lifter 1 to rest the presser foot/roller presser on the needle plate.
- 15.3 Reduce the pressure on the presser bar by turning out regulating screw 2 so that it is just sufficient to hold the presser foot/roller presser down on the needle plate.
- 15.4 Push the 7-mm-thick blade of the gauge under the presser foot fulcrum or the roller presser.
- 15.5 Loosen clamp screw 3.
- 15.6 Raise presser bar lifter 1.
- 15.7 On machines with presser foot, turn the balance wheel until the needle is down in the needle hole of the presser foot.
- 15.8 Adjust the presser foot so that the needle is centered exactly in the needle hole; on machines with roller presser, set the roller presser as close to the needle as possible, with its sides parallel to the rows of the feed dog.
- 15.9 **With the presser foot/roller presser in this position, push presser bar lifting bracket 4 downwards onto the raised lifting lever 5 and tighten clamp screw 3 securely.**
- 15.10 Remove the gauge from under the presser foot/roller presser and lower the foot onto the needle plate.
- 15.11 Loosen the retaining screw of presser bar bushing 6 (accessible through the hole below presser bar lifter 1).
- 15.12 **Adjust presser bar bushing 6 so that between its lower edge and the presser foot/roller presser mounting there is a distance of approx. 10 mm.**
- 15.13 In this position, tighten the retaining screw of presser bar bushing 6.
- 15.14 Check this adjustment (see "Setting").

16 Tension release mechanism

Setting:

With presser bar lifter 1 raised, both tension discs must be at least **0.5 mm** apart.

Note:

When thicker needle threads are used, the tension discs must be wider apart accordingly.

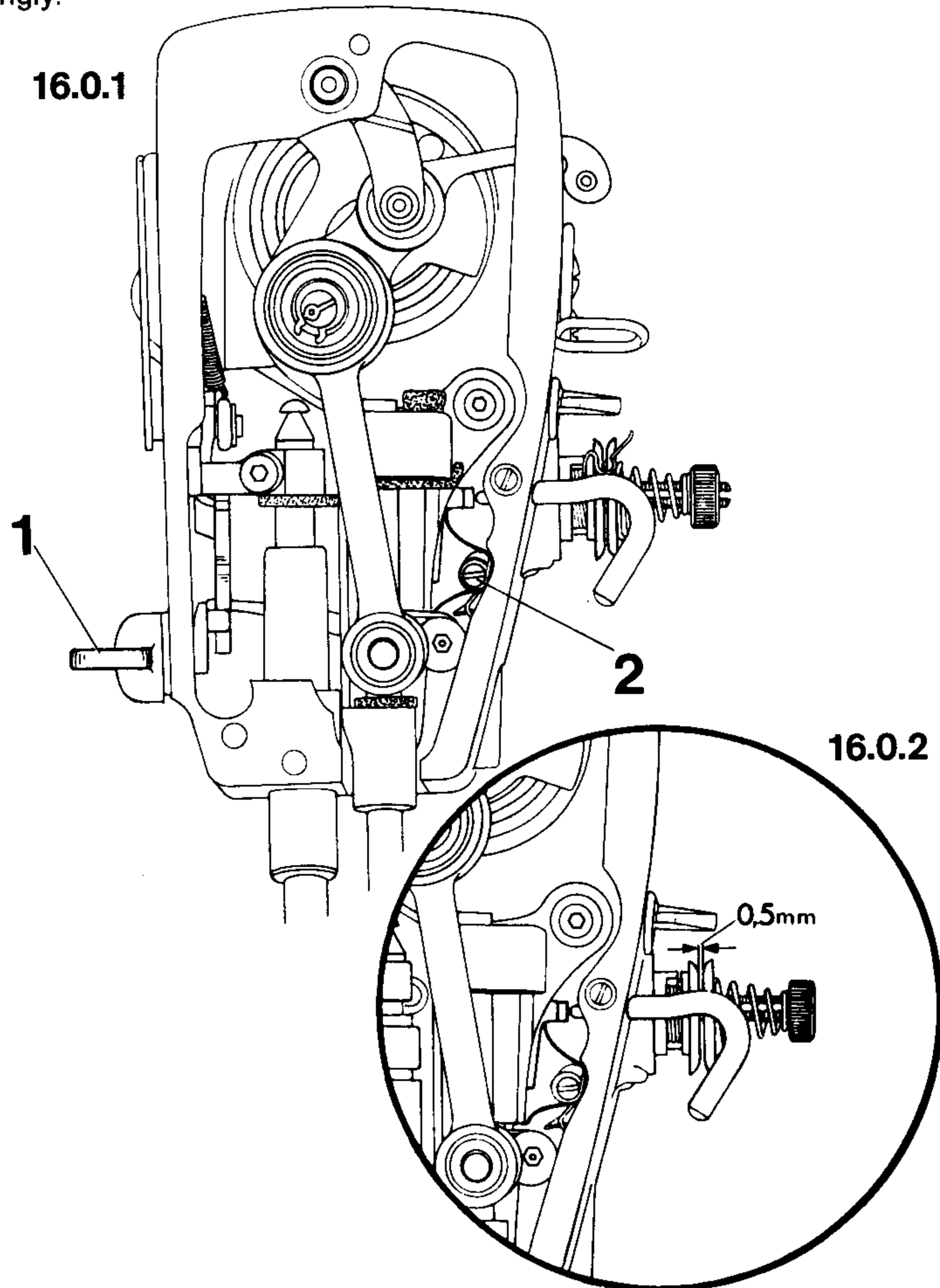

Adjustment:

- 16.1 Raise the presser foot/roller presser by means of presser bar lifter 1.
- 16.2 **Loosen the lock screw of eccentric stud 2** (accessible through the hole on the opposite side of the machine head) **and turn the stud so that the two tension discs are at least 0.5 mm apart.**
- 16.3 In this position, tighten the lock screw of eccentric stud 2 securely.
- 16.4 Lower the presser foot/roller presser onto the needle plate and check to make sure the tension is fully activated.
- 16.5 Check this adjustment (see "Setting").

17 Thread check spring and thread regulator

Setting:

The stroke of thread check spring 3 must be approx. 7 mm.

Note:

The stroke of thread check spring 3 and the position of thread regulator 5 are dependent on the type of thread and material used and must be adjusted according to the appearance of the seam. Thread regulator 5 must be positioned in its elongated hole so that thread check spring 3 has travelled approx. 2 mm when the sewing hook has widened the thread loop to its extreme.

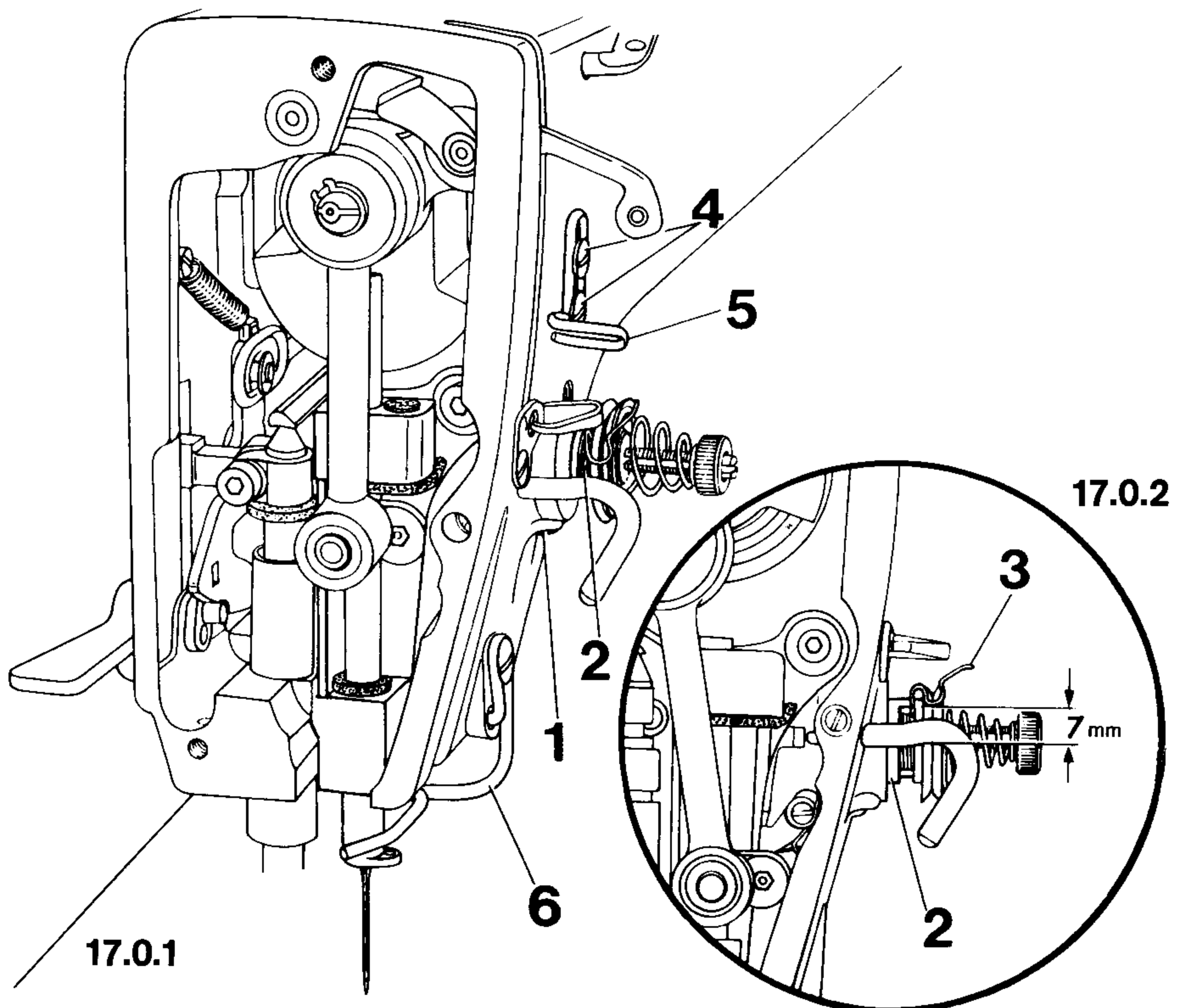

Adjustment:

- 17.1 Loosen screw 1.
- 17.2 **Turn tension barrel 2 until the stroke of thread check spring 3 amounts to approx. 7 mm.**
(Special sewing operations may make it necessary to set the thread check spring for a shorter or longer stroke.)
- 17.3 In this position, tighten screw 1.
- 17.4 Check this adjustment (see "Setting").
- 17.5 Loosen screws 4, push thread regulator 5 up as far as it will go, tighten screws 4 again and check according to "Note".
- 17.6 Screw on thread guide 6.

18 Knee lever rest position

Setting:

When at rest, knee lever connecting rod **2** must be roughly at right angles to the front edge of the bedplate.

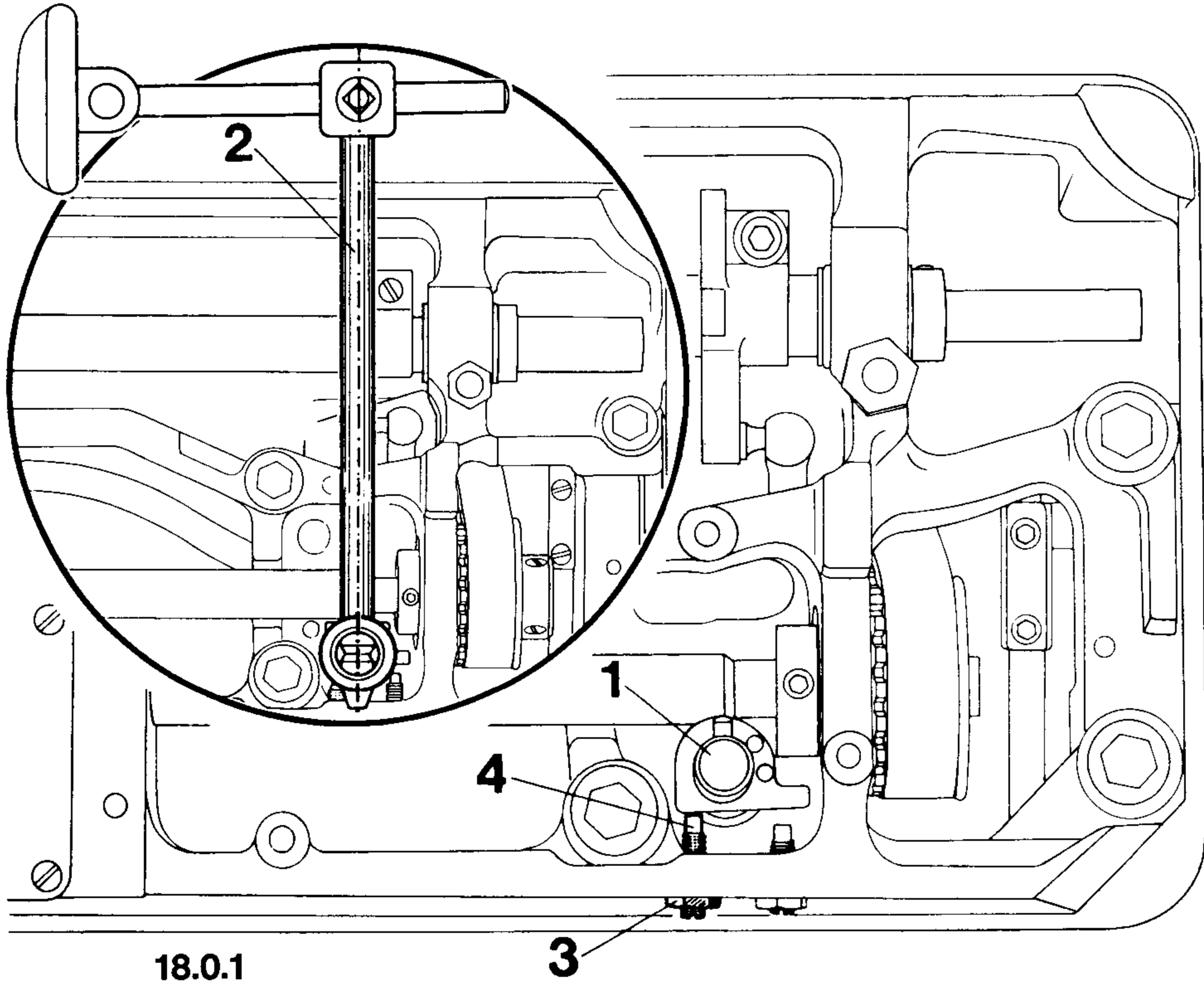

Adjustment:

- 18.1 Raise the presser foot/roller presser by means of the presser bar lifter.
- 18.2 Push the knee lever joint onto knee lever shaft **1** and let connecting rod **2** snap in place in the joint.
- 18.3 Loosen locknut **3**.
- 18.4 **Turn stop screw **4** until connecting rod **2** extends roughly at right angles to the front edge of the bedplate.**
- 18.5 In this position, lock stop screw **4** by tightening nut **3**.
- 18.6 Remove the knee lever.

Setting:

When the presser foot/roller presser is down on the needle plate, there must be a clearance of approx. **0.6 mm** between lifting lever **3** and lifting bracket **4**.

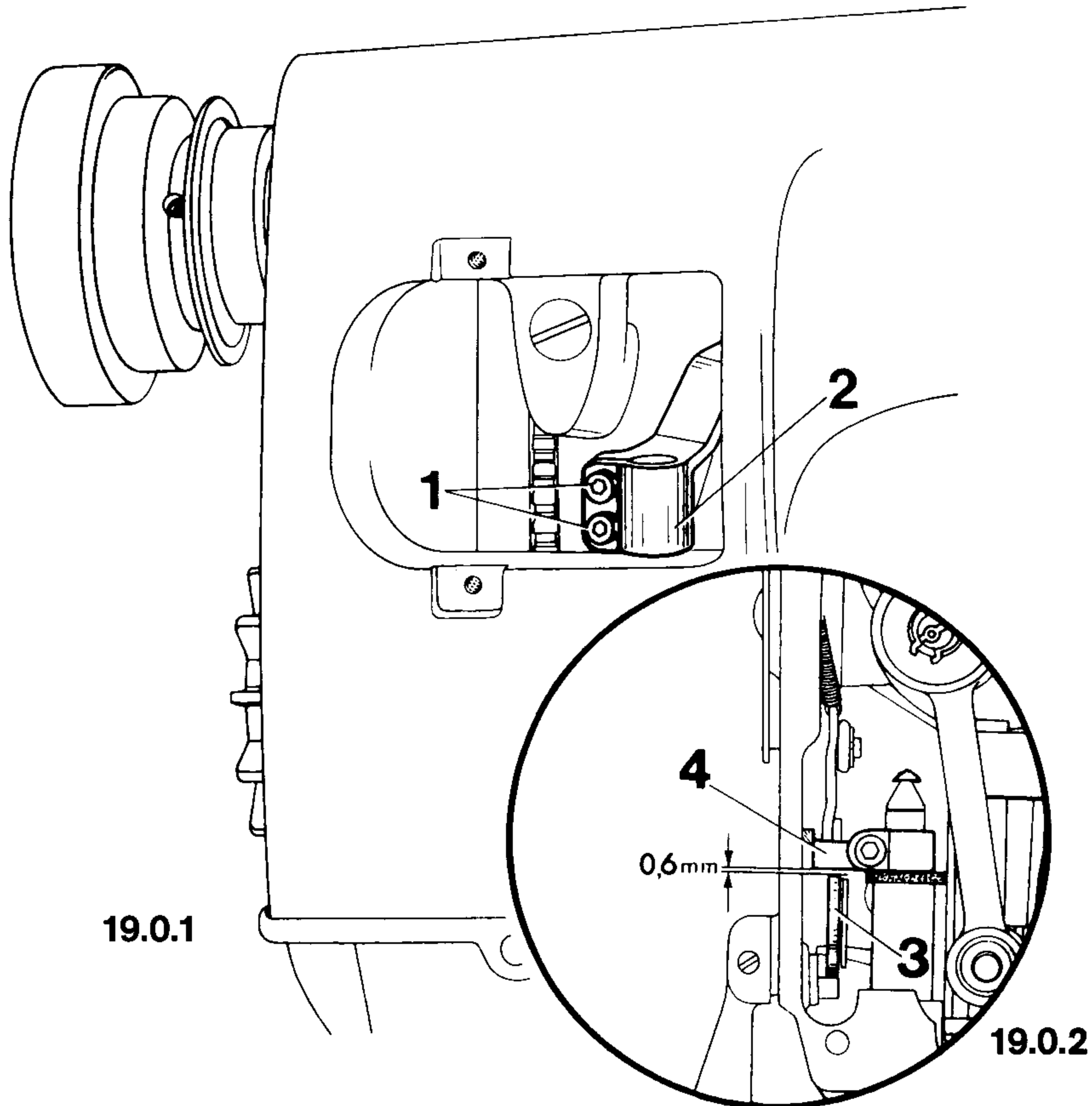

Adjustment:

- 19.1 Set the needle bar at b.d.c. and let the presser foot/roller presser down on the needle plate.
- 19.2 Take out the two screws of the rear arm cover and remove the cover.
- 19.3 Loosen clamp screws 1.
- 19.4 **Adjust crank 2 so that there is a clearance of approx. 0.6 mm between lifting lever 3 and lifting bracket 4.** (use a gauge for this adjustment.)
- 19.5 In this position, tighten clamp screws 1, making sure the vertical knee lever shaft has no end play.
- 19.6 Remove the gauge.
- 19.7 Check this adjustment (see "Setting").

20 Knee lever stroke limitation

Requirement: The presser foot/roller presser must be raised.

Setting:

When the knee lever is fully operated, the presser foot/roller presser must be lifted from the needle plate by approx. **9 mm**, and the presser bar lifter must drop by its own weight.

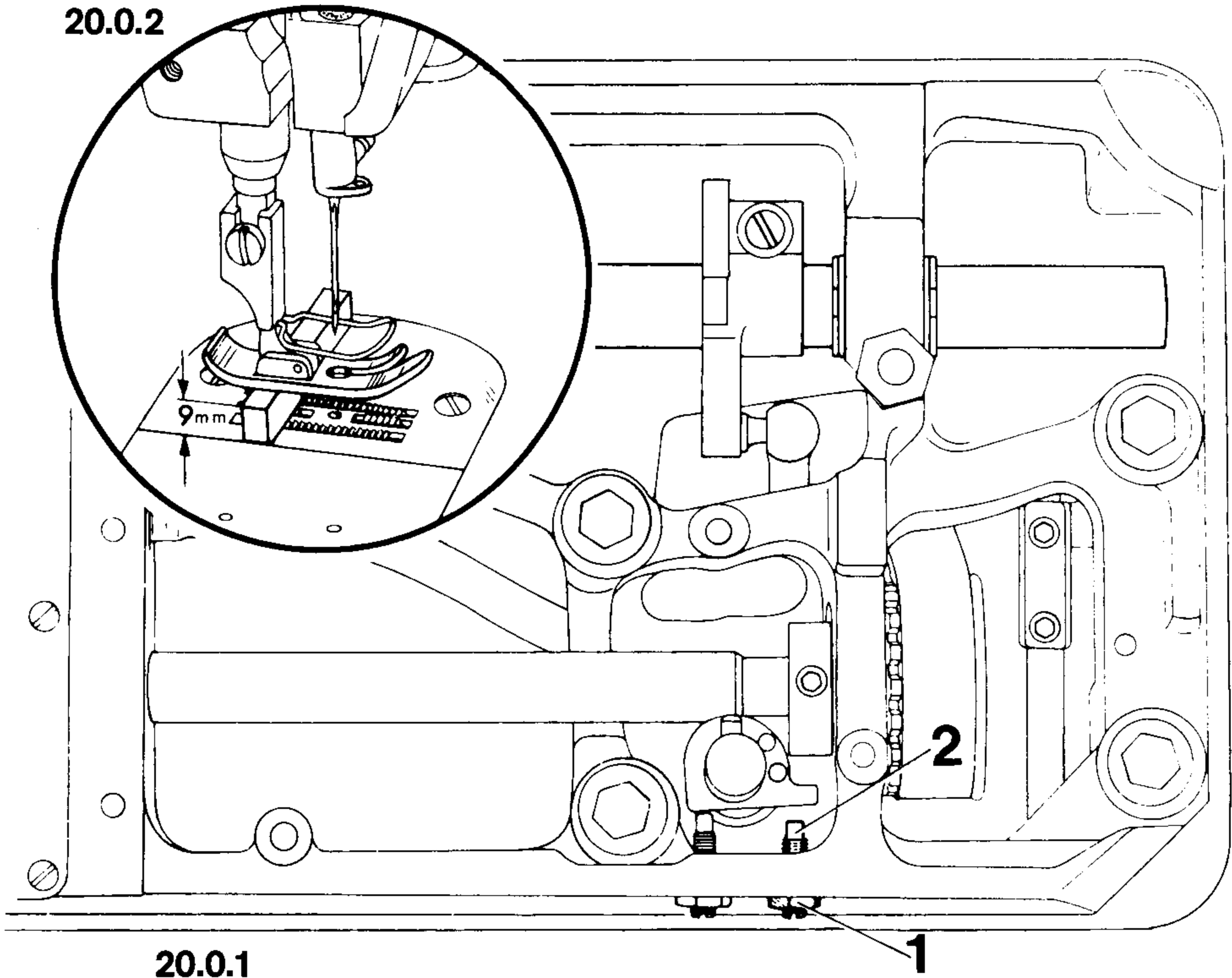

Adjustment:

- 20.1 Loosen locknut 1.
- 20.2 Turn stop screw 2 out a few turns.
- 20.3 Raise the presser bar lifter and insert the knee lever.
- 20.4 Place a 9 mm-thick object (e.g. a bobbin) under the presser foot/roller presser and lower the presser bar lifter again.
- 20.5 Push the knee lever to the right until a resistance is felt; during this motion, however, the presser foot/roller presser must not be lifted off the gauge.
- 20.6 **Hold the knee lever in this position and turn in stop screw 2 as far as it will go, then out again by half a turn. Lock stop screw 2 by tightening nut 1.**
- 20.7 Remove the 9 mm-thick object from under the presser foot/roller presser.
- 20.8 Check this adjustment (see "Setting").
- 20.9 Screw on the face plate.

Setting:

The bobbin winder must wind the thread evenly on the bobbin and stop automatically when the thread has reached a point approx. **1 mm** below its rim.

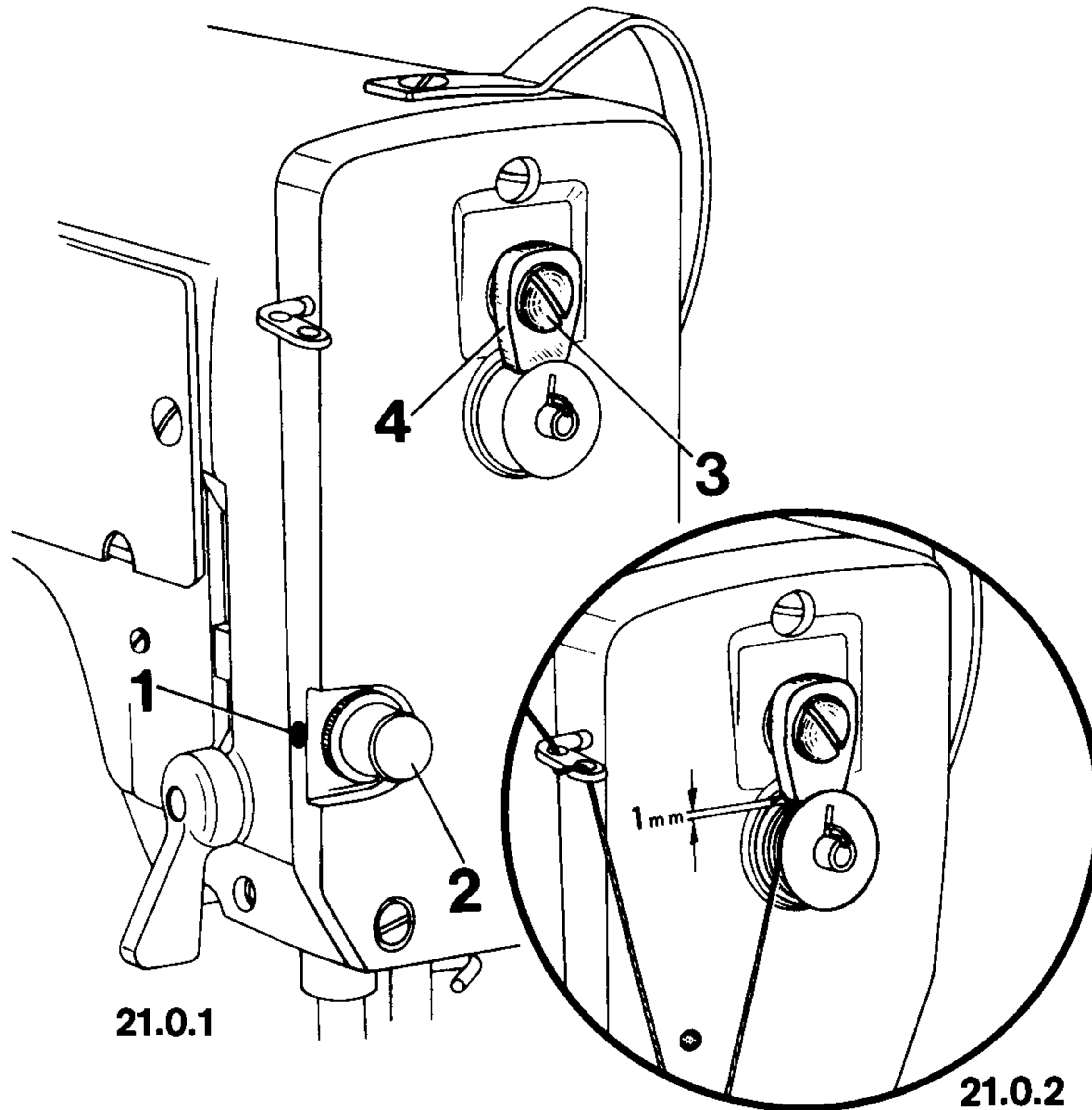

Adjustment:

- 21.1 Place a bobbin on the winder spindle, thread the machine for bobbin winding, engage the bobbin winder and start the machine.
- 21.2 Loosen screw 1.
- 21.3 Adjust the position of thread retainer stud 2 until the thread is wound evenly on the bobbin.
- 21.4 Tighten screw 1.
- 21.5 Loosen screw 3.
- 21.6 If the bobbin is not full enough, push stop latch 4 upwards, if the bobbin is too full, push it downwards.
- 21.7 Tighten screw 3.
- 21.8 Check this adjustment (see "Setting").

22

Stitch length limitation

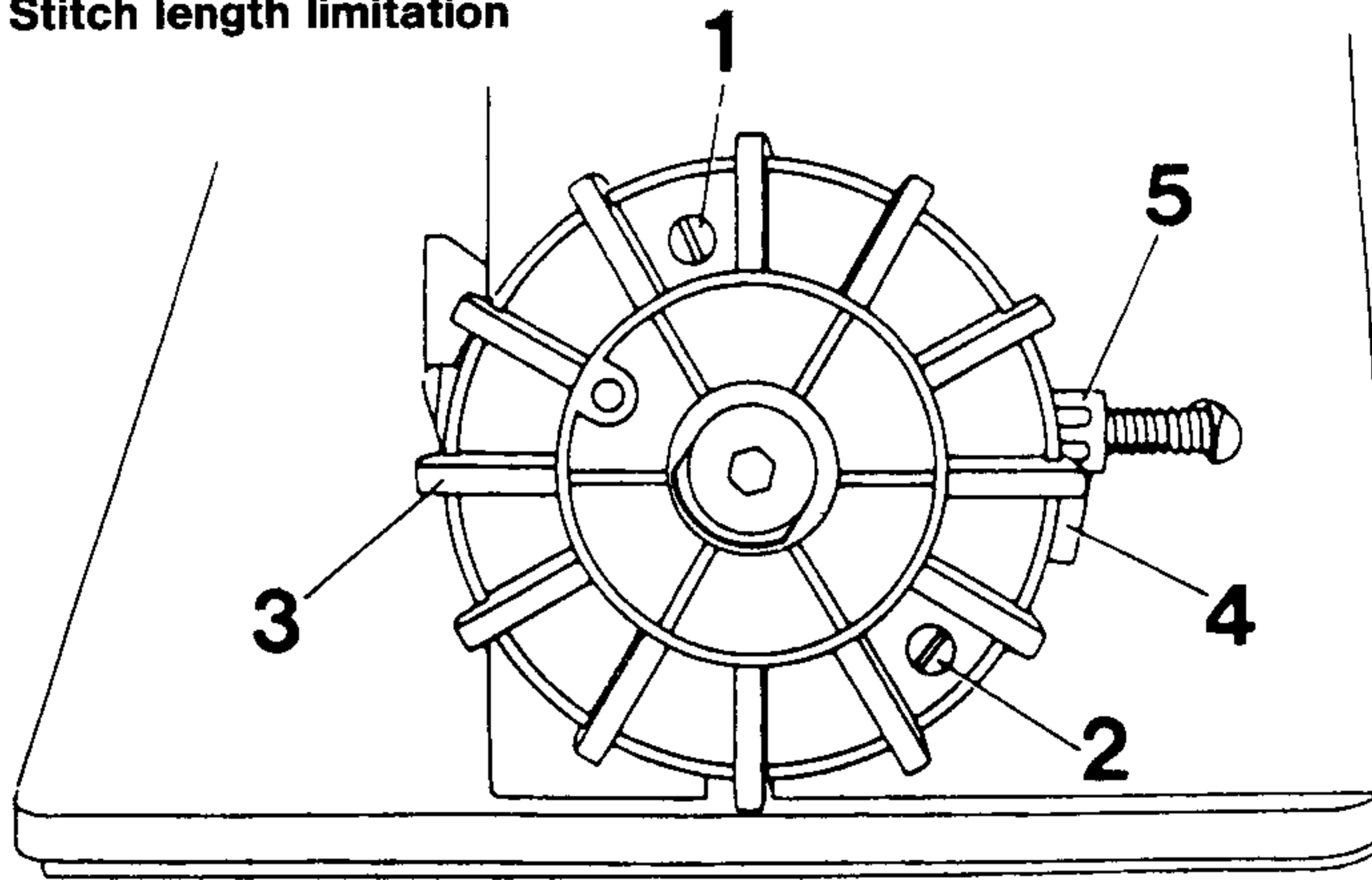

22.0.1

Adjustment:

- 22.1 Loosen screws 1 and 2.
- 22.2 Set the maximum required stitch length at feed regulator wheel 3.
- 22.3 **Turn the limitation ring so that its lug 4 moves against stop 5 from below.**
- 22.4 In this position, tighten screws 1 and 2.

23

Stitch length adaption

Setting:

With the stitch length set at "3", forward and reverse stitches must be of equal length.

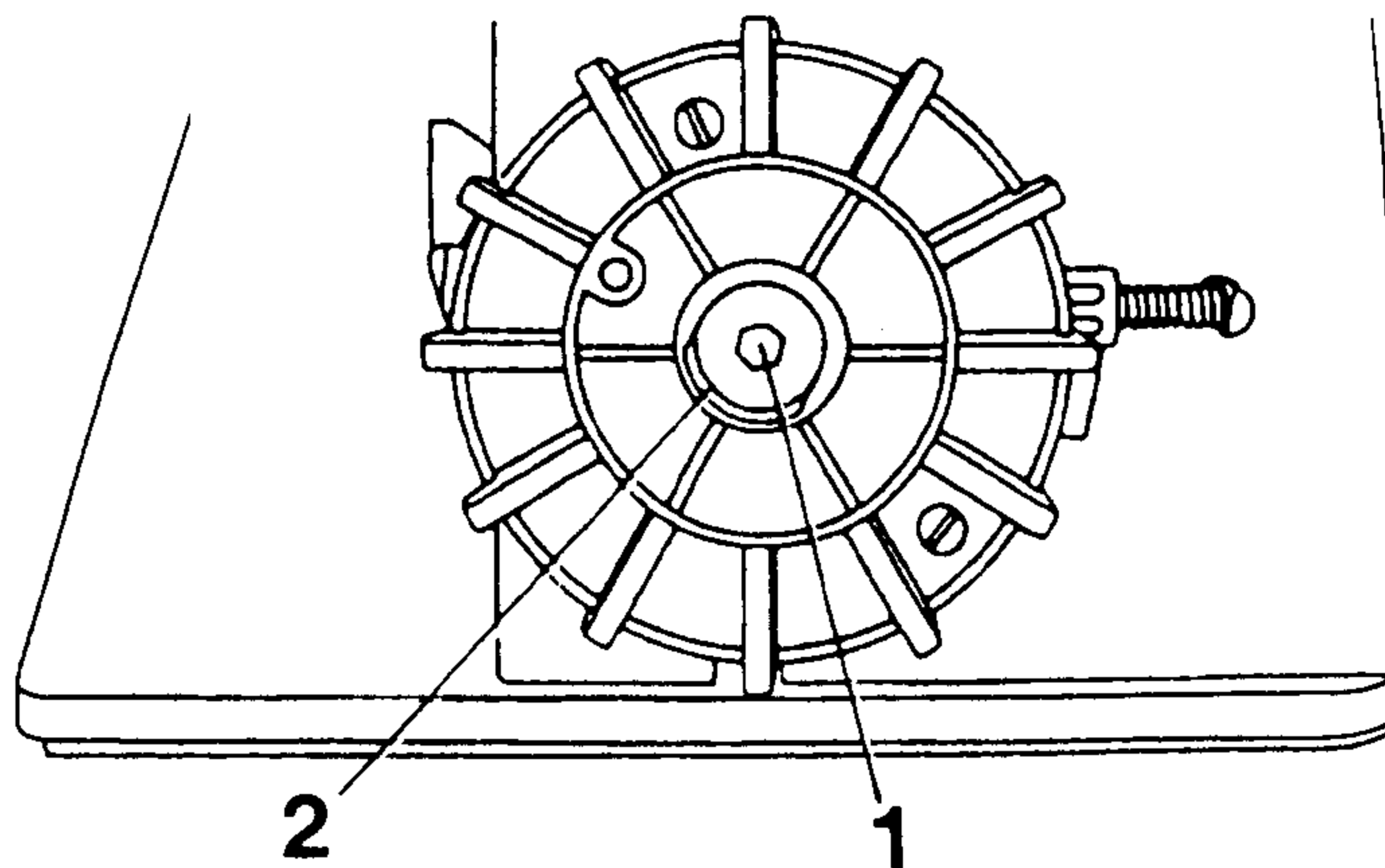

23.0.1

Adjustment:

- 23.1 Set stitch length at "3".
- 23.2 Loosen screw 1.
- 23.3 **Making sure that the lobe of bush 2 points downward, turn the bush slightly until forward and reverse stitches are of equal length.**
- 23.4 In this position, tighten screw 1.
- 23.5 Check this adjustment (see "Setting").

- 24 Final worksteps**
- 24.1 Screw on the rear arm cover and the belt guard.
- 24.2 Replace the bed slide and insert the knee lever in its joint.
- 24.3 Thread the machine, place a piece of fabric under the needle and lower the presser foot/roller presser onto it.
- 24.4 Adjust the presser foot pressure by turning in regulating screw 2 (Fig. 15.0.1) so that the fabric is fed properly even at top speed.

Contents

	Page
1 Zeroing the feed motion	1-2
2 Feed lifting motion	3
3 Feed dog height	4
4 Feed driving motion	5
5 Centering the needle in the needle hole	6
6 Preliminary adjustment of needle bar height	7
7 Eccentric hook shaft bearing	8
8 Needle bar height (final adjustment), hook timing and hook-to-needle clearance	9
9 Height of bobbin case opener	10
10 Position of bobbin case opener	11
11 Timing the bobbin case opener	12
12 Oil tube and oil thrower	13
13 Oil check valve	14
14 Hook lubrication	15
15 Clearance between presser foot/roller presser and needle plate	16-17
16 Tension release mechanism	18
17 Thread check spring and thread regulator	19
18 Knee lever rest position	20
19 Knee lever play	21
20 Knee lever stroke limitation	22
21 Bobbin winder	23
22 Stitch length limitation	24
23 Stitch length adaption	24
24 Final worksteps	25

