

PFAFF® 417
437

Service Manual

Pfaff, D 6750 Kaiserslautern, Postfach 3020/3040, Telex: 045 753

PFAFF INDUSTRIAL OF AMERICA

3910 Green Industrial Way
Atlanta, Georgia 30341

With the 5 mm hole of the counter balance positioned at TDC, install the take-up assembly with the crank driving pin positioned to the back of the machine. Install the timing plate along with the bearing as an assembly. Tighten the three counter sunk screws of the timing plate. Rotate the handwheel a few turns and tighten the pinch screw behind the timing plate. Tighten the two pinch screws of the counter balance.

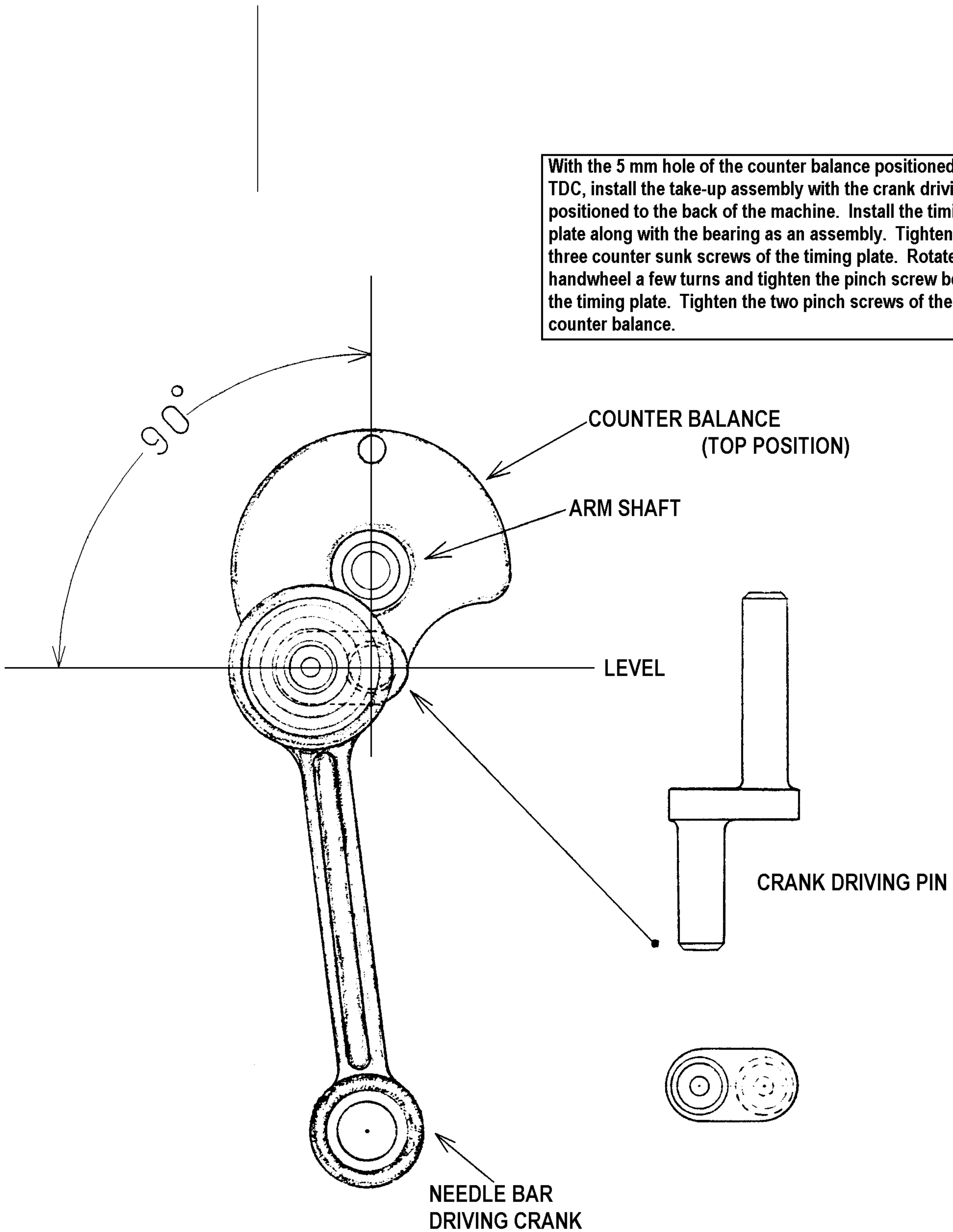

Instructions for adjusting Pfaff 417 and 437 machines

Important note

Do not use a C-clamp on the needle bar of Pfaff **417 and 437** machines as this would damage its special coating. Make sure you check the hook lubrication system (see Section 37) on machines in operation for the first time or which have been idle for a longer period (i. e. 1 or 2 months).

For shipping purposes the oil is drained from the needle vibrating eccentric housing of the Pfaff 417 and 437. It is therefore necessary to fill this housing with 100 c.c. of oil (see Section 36) before operating the machine for the first time. A sticker on the machine arm serves as a reminder.

When the machine is given a general overhaul put about **2 c.c.** of pinion grease, with a dripping point of 160°C, in the bevel-gear case of the hook. We recommend you use **Molykote-Longtherm 00**. This grease can be obtained from us under No. 280-1-120 199.

Tools, gauges and other accessories required for adjusting the machines

- 1 set of screwdrivers with 2 to 10 mm wide blades
- 1 set of allen keys from 1.5 to 6 mm
- 1 set of wrenches with openings from 7 to 14 mm wide
- 1 wrench with 27-mm-wide opening
- 1 metal ruler
- 1 cylindrical pin (5 mm dia.), No. 13-030 341-05
- 1 feed dog gauge, No. 91-129 995-05
- 1 hook bearing bracket gauge, No. 91-129 996-05
- 1 wrapper of system 438 needles
- 2 strips of white paper
- 1 roll of adhesive tape
- Sewing thread and testing material

1

Preparations for adjusting

Note:

To allow the machine to be blocked with the needle bar at the required position the bearing plate (Fig. 1.0.1.) has four holes.
After positioning the needle bar as required push the pin into the appropriate hole until it enters the recess behind the bearing plate, thus blocking the machine.

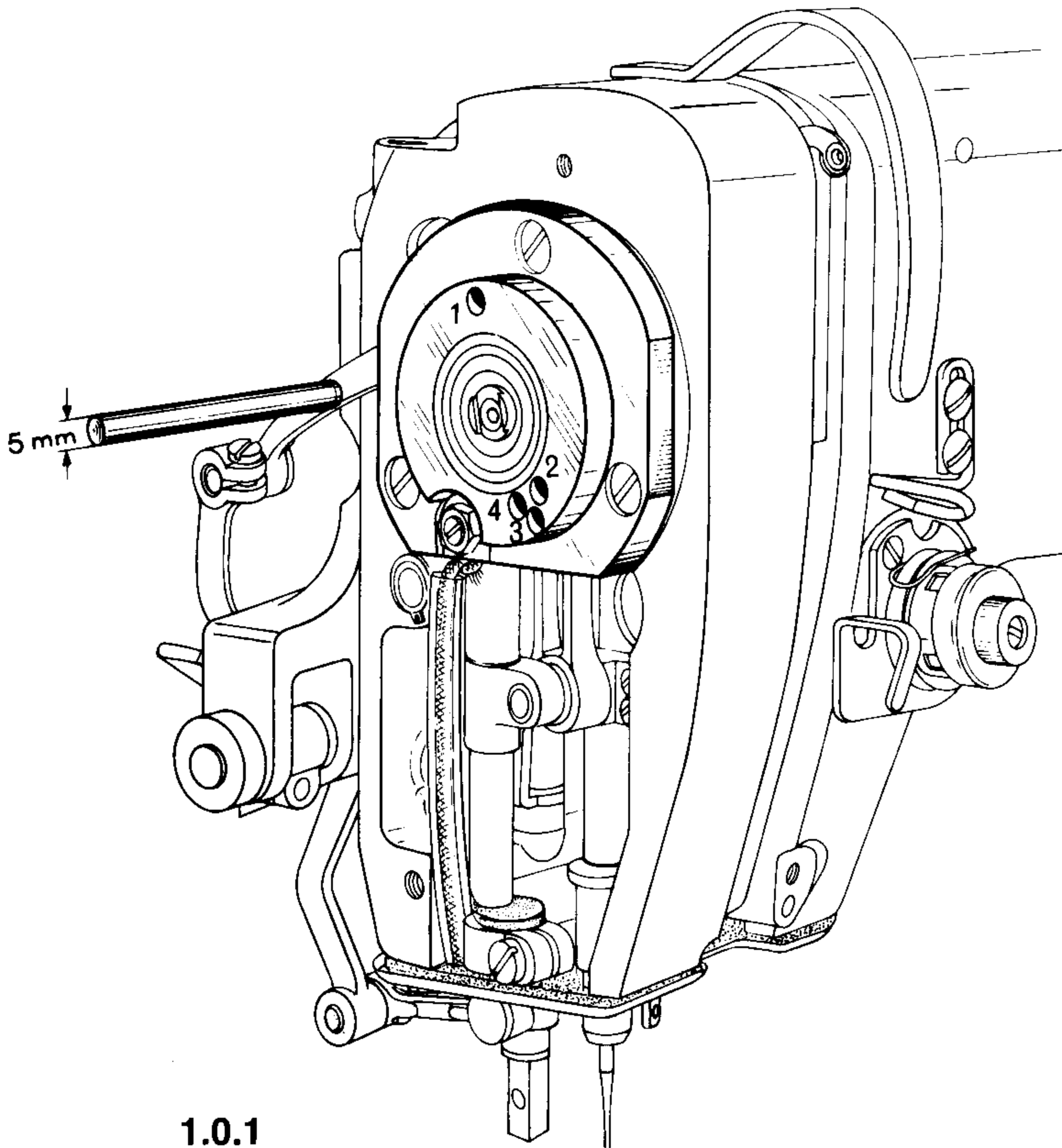

1.0.1

The function of the four holes is as follows:

Hole 1 = 2 mm beyond bottom dead centre (b.d.c.) of needle bar

Hole 2 = top dead centre (t.d.c) of needle bar

Hole 3 = 0.25 mm beyond t.d.c. of needle bar

Hole 4 = 1 mm beyond t.d.c. of needle bar

- 1.1 Unscrew the two screws in the face cover and remove the cover.
- 1.2 Take out screw 2 and remove the presser foot.
- 1.3 Take out screw 3 and remove the thread guide.
- 1.4 Loosen screw 4 of the thread control and remove the latter by pulling it downwards.
- 1.5 Unscrew allen screws 5 (do not remove cover plate 6 as it is connected to oil wick 9).
- 1.6 Loosen clamp screw 7 and pull stabilizing rod 8 down a little.
- 1.7 Remove plate 6 with oil wick 9.
- 1.8 Insert a new needle (system 438) and push it up as far as it will go; the long groove should face the front.

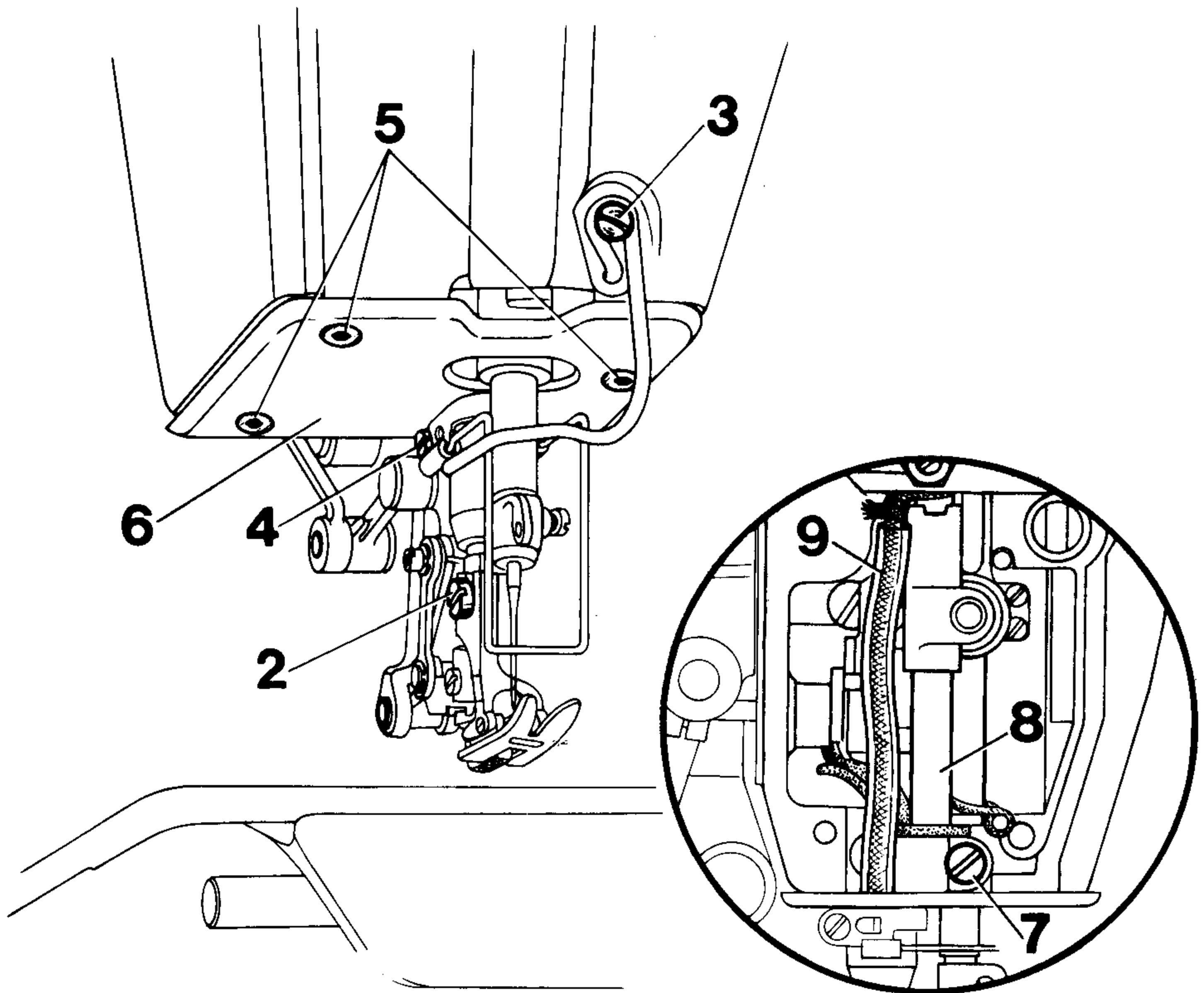

1.0.2

1.0.3

2 Centring the needle in the needle hole (in sewing direction)

Correct setting:

When the stitch width is set at "0" and the needle position lever is in its central position the needle should enter the needle hole exactly in the middle (in sewing direction).

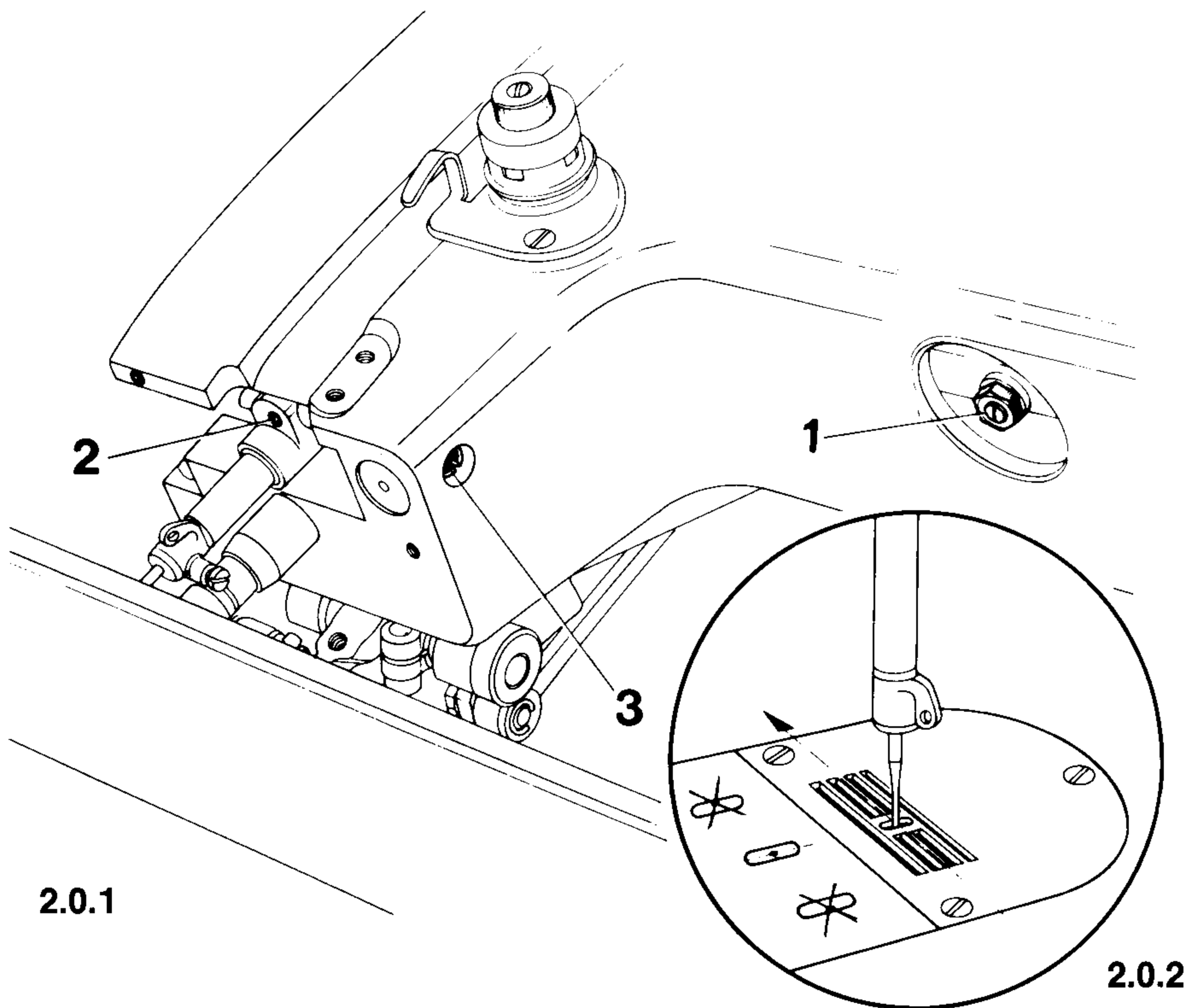

- 2.1 Set the needle position lever at "centre" and the stitch width lever at "0".
- 2.2 Remove the plastic plugs on the underside of the arm.
- 2.3 Bring the needle bar to its b.d.c.
- 2.4 Loosen jam nut 1 and allen screw 2.
- 2.5 **Turn eccentric stud 3 until the needle - as seen in sewing direction - is centred in the middle of the needle hole.**
- 2.6 In this position, tighten allen screw 2 and jam nut 1.
- 2.7 Check this adjustment (see "Correct setting").

3 Setting the stabilizing rod parallel to the needle bar

Correct setting:

Stabilizing rod 4 should be parallel to the needle bar.

Note:

The lobe of eccentric stud 3 should always point downwards.

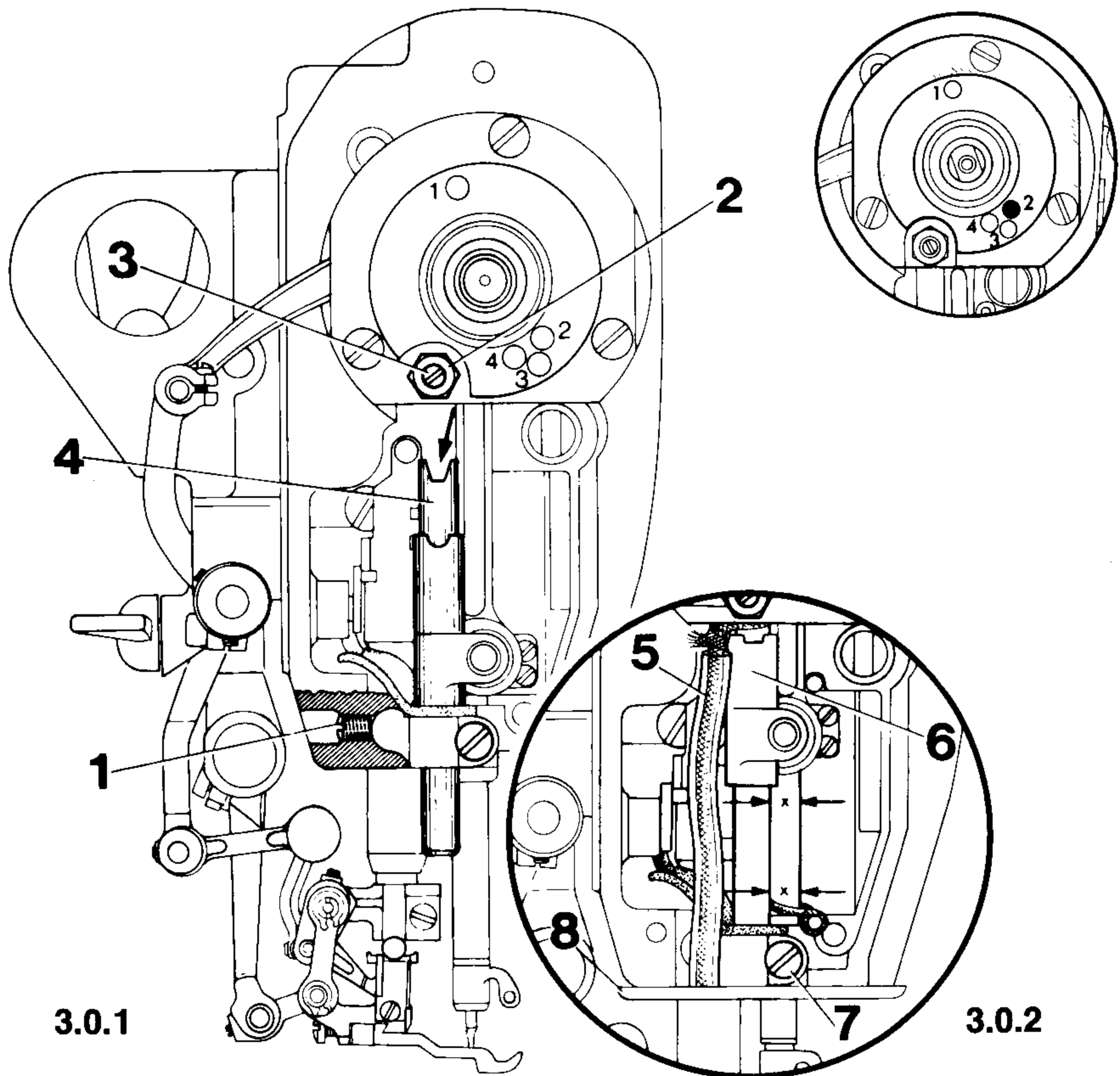

- 3.1 Bring the needle bar to t.d.c. and insert the pin in hole "2" of the bearing plate (to block the machine).
- 3.2 Loosen screw 1 (accessible from the back of the machine arm).
- 3.3 Loosen jam nut 2 and turn eccentric stud 3 so that its lobe points downwards.
- 3.4 Insert stabilizing rod 4 in the loop of oil wick 5.
- 3.5 Position stabilizing rod 4 so that the recess at its top end (see arrow in Fig. 3.0.1) touches eccentric stud 3.
- 3.6 **Hold stabilizing rod 4 firmly and turn eccentric stud 3 until stabilizing rod 4 is parallel to the needle bar (Fig. 3.0.2).**
- 3.7 In this position tighten eccentric stud 3 with nut 2.

- 3.8 To check that it is parallel to the needle bar first pull stabilizing rod **4** down and then push it up again as far as it will go, making sure that guide **6** does not move to the side (if necessary repeat adjustment steps 3.3, 3.4, 3.5, 3.6 and 3.7).
- 3.9 Making sure that stabilizing rod **4** is still in contact with eccentric stud **3** tighten clamp screw **7** securely.
- 3.10 Remove the cylindrical pin from the hole in the bearing plate.
- 3.11 Bring the needle bar to b.d.c. and tighten screw **1** which is accessible from the back of the machine arm.
- 3.12 Screw on cover plate **8**.

4 Stitch width control

4.1 Zeroing the needle for straight stitching

Correct setting:

When the stitch width control is set at "0" the needle bar should not move to the side.

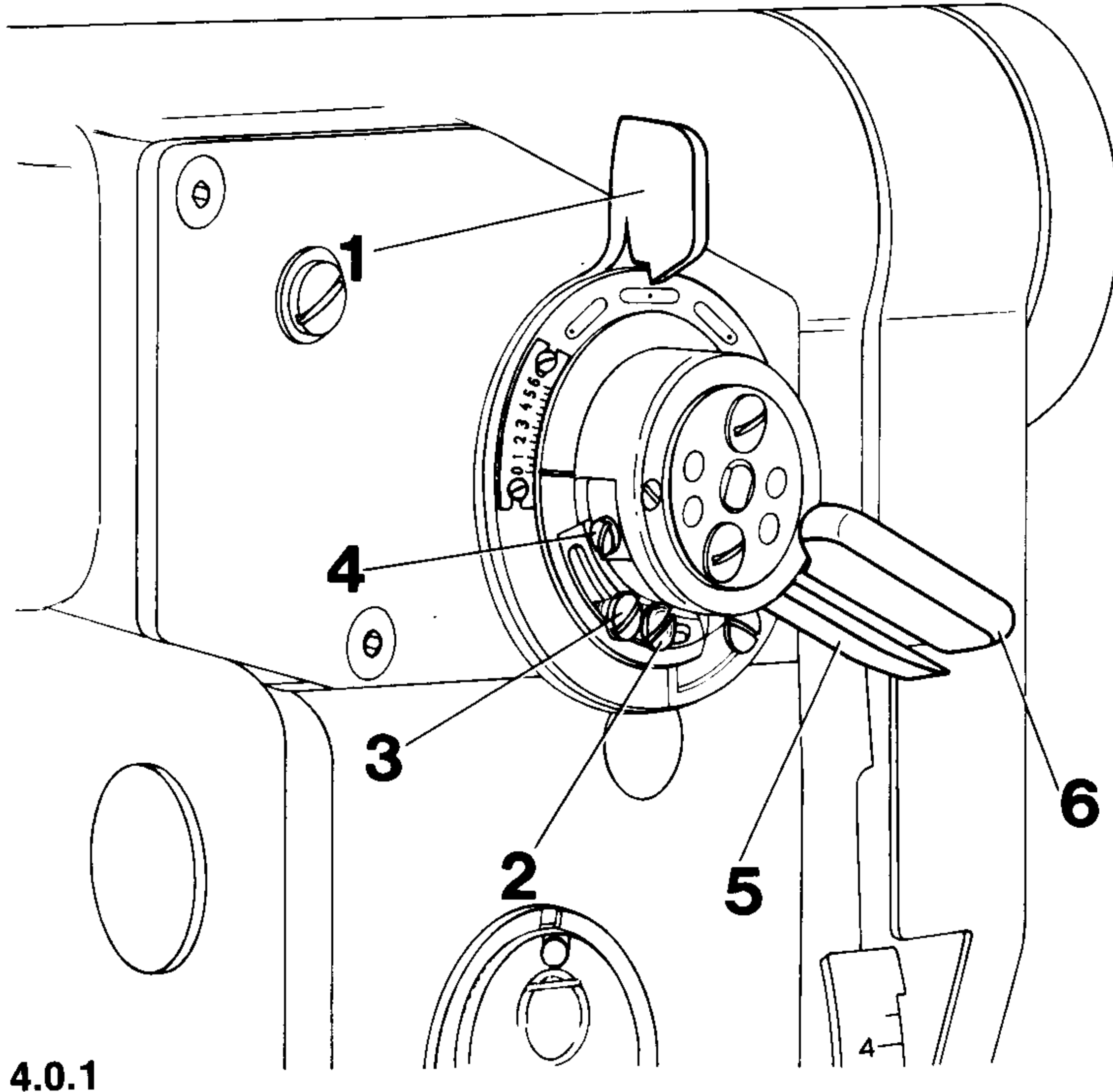

4.0.1

- 4.1.1 Set needle position lever **1** at its central position.
- 4.1.2 Loosen screws **2** and **3**.
- 4.1.3 Loosen clamp screw **4** and let locking lever **5** move back until its spring is relaxed.
- 4.1.4 In this position, tighten clamp screw **4**.
- 4.1.5 Move stitch width lever **6** to the right as far as it will go (i.e. towards "0").
- 4.1.6 Turn on the master switch and let the machine run slowly. **Move stitch width lever 6 to the left until the needle bar stops swinging sideways.**
- 4.1.7 In this position push screw **2** to the right as far as it will go and tighten it.
- 4.1.8 Check this adjustment (see "Correct setting").
- 4.1.9 Switch off master switch.
- 4.1.10 Screw **3** is still loose.

4.2

Stitch width scale

Correct setting:

When the stitch width control is set at "0" the zero mark on the stitch width scale should be opposite mark 3 of the stitch width lever.

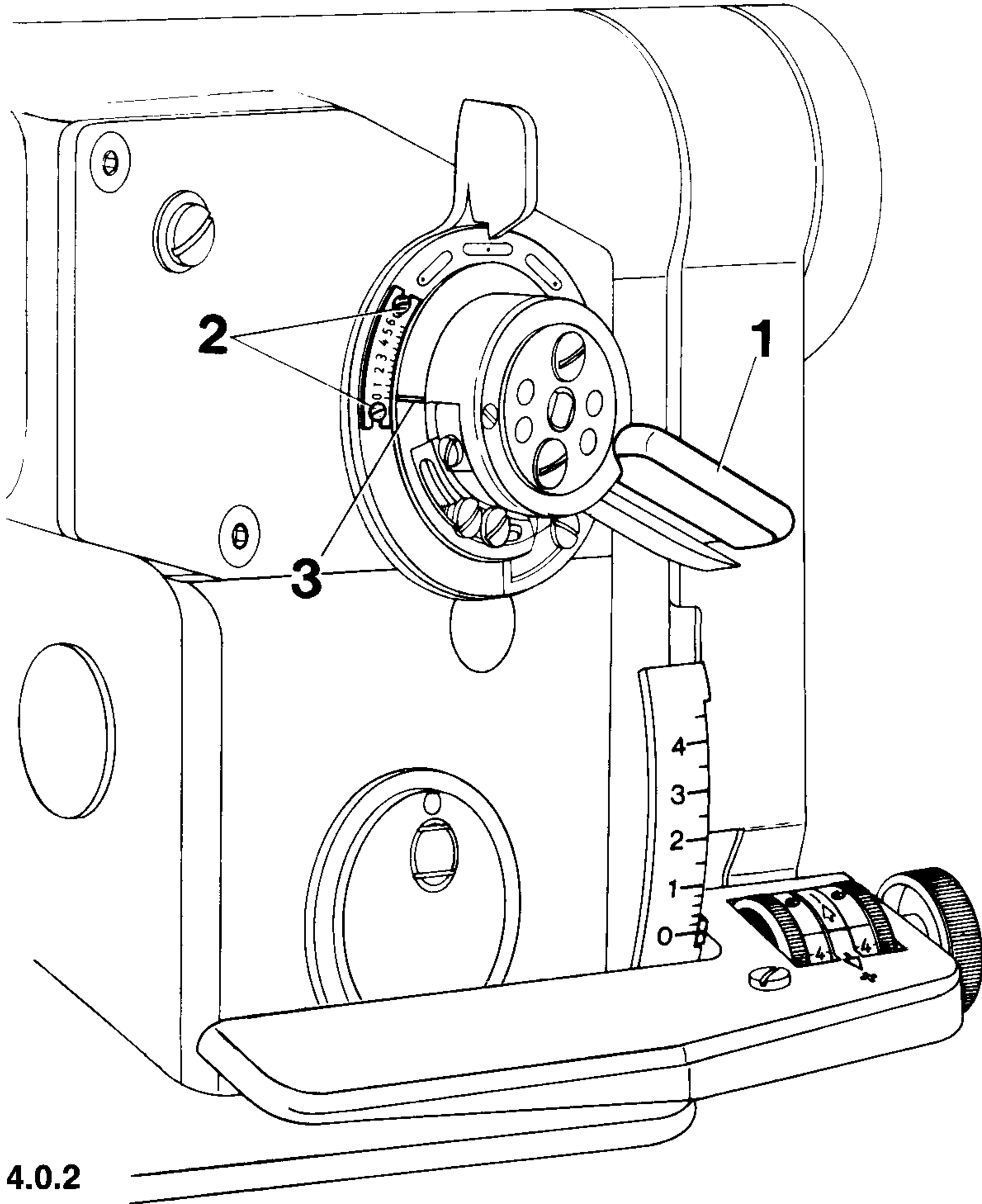

4.0.2

- 4.2.1 Move stitch width lever 1 to the right as far as it will go.
- 4.2.2 Loosen screws 2.
- 4.2.3 **Adjust the stitch width scale until the zero mark is opposite mark 3 of stitch width lever 1.**
- 4.2.4 In this position tighten both screws 2.
- 4.2.5 Check this adjustment (see "Correct setting").

4.3

Limiting the maximum stitch width

Correct setting:

When the maximum stitch width is set mark 2 of the stitch width lever should be opposite the maximum stitch width mark on the stitch width scale.

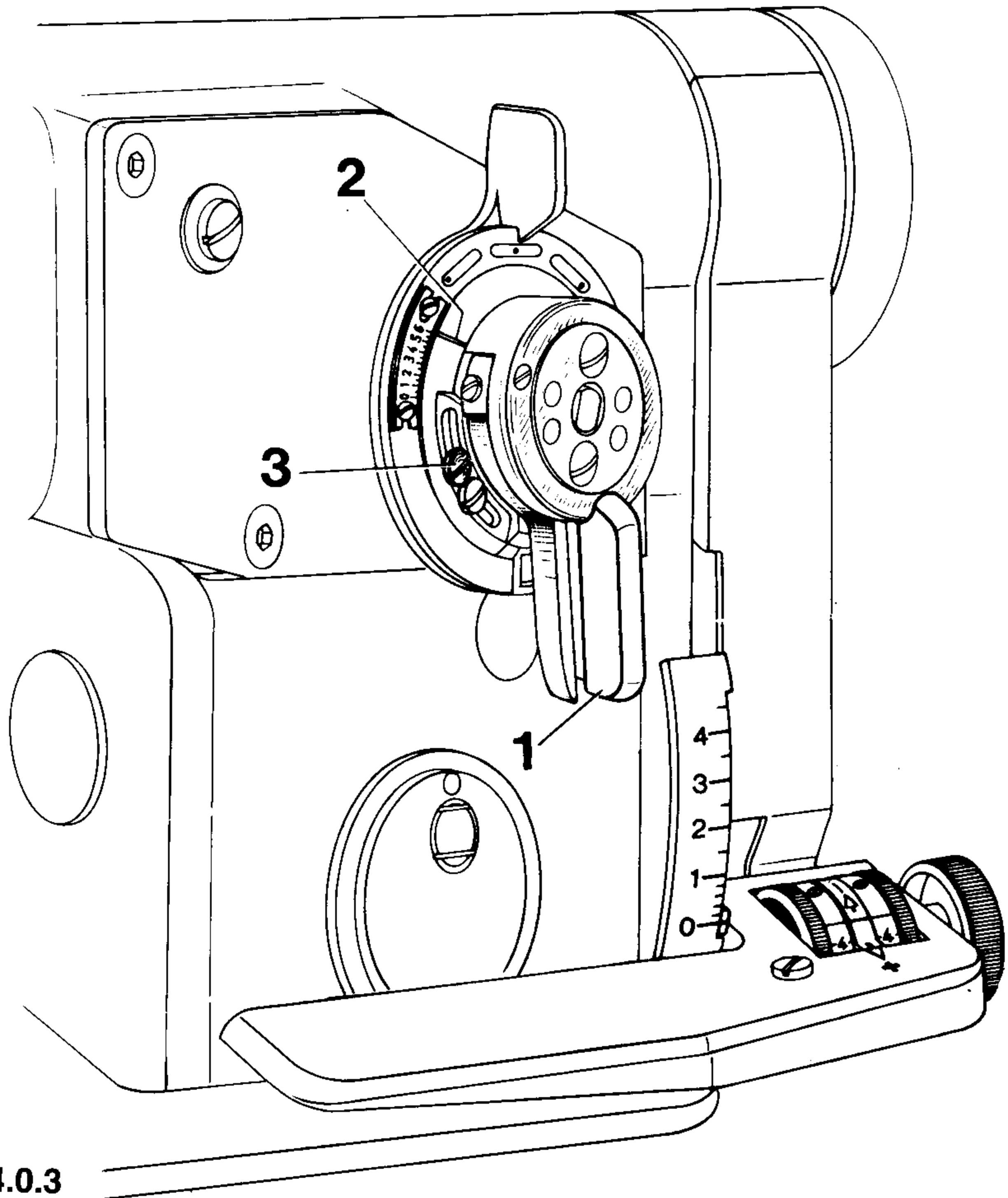

4.0.3

- 4.3.1 **Move stitch width lever 1 to the left until mark 2 is opposite the maximum stitch width mark on the stitch width scale.**
- 4.3.2 In this position move stop screw 3 which limits the maximum stitch width upwards as far as it will go and tighten it.
- Note: If for certain sewing operations the machine is equipped with a needle plate whose hole is smaller than the widest stitch width indicated on the scale, limit the stitch width according to the width of the needle hole rather than the graduation mark on the stitch width scale.
- 4.3.3 Check this adjustment (see "Correct setting").

Correct
setting:

The locking lever 2 should be adjusted so that stitch width lever 3 can be locked in any position.

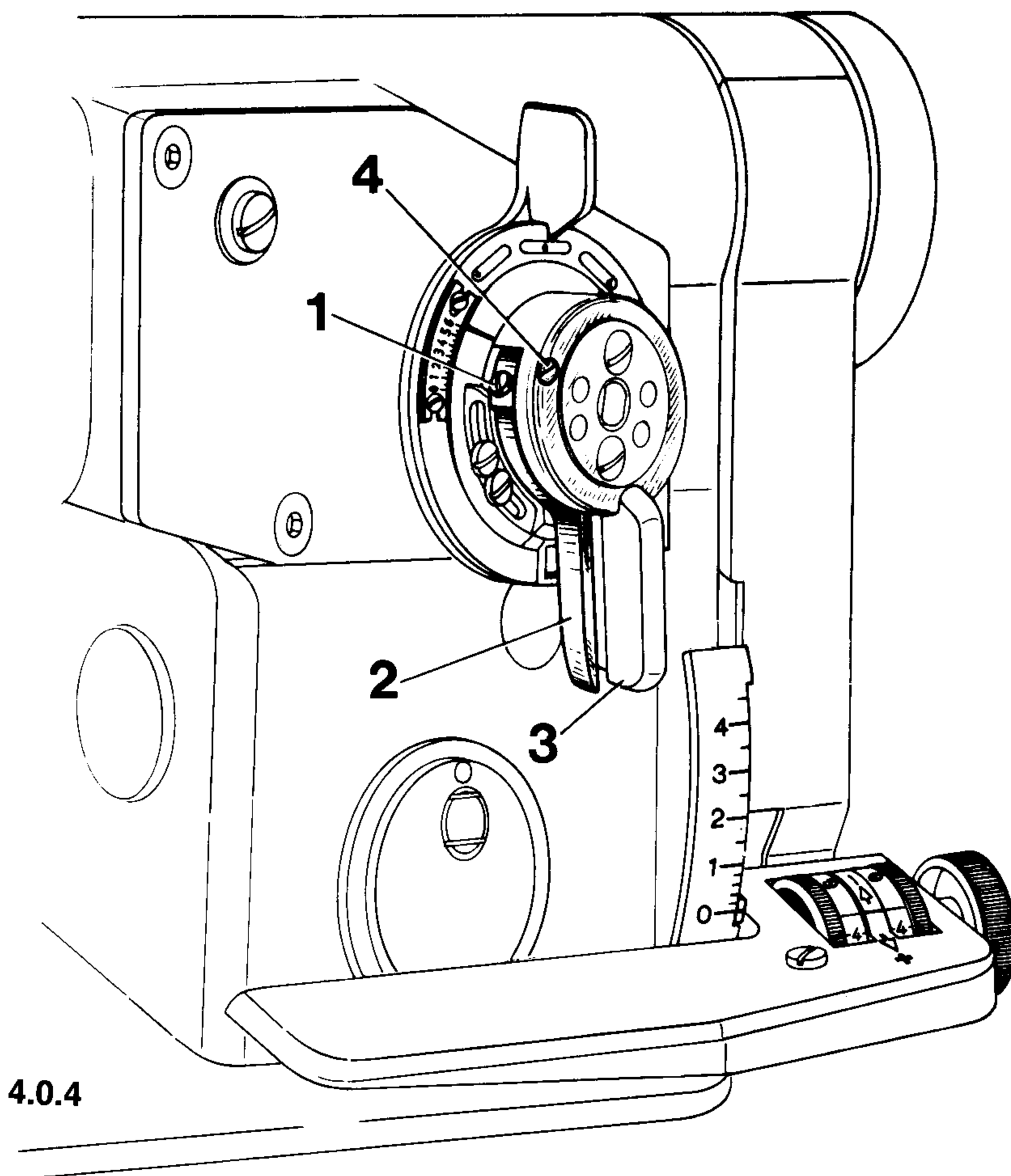

4.0.4

- 4.4.1 Loosen clamp screw 1 of locking lever 2, making sure that the pressure spring in the locking lever does not fall out.
- 4.4.2 **Pull locking lever 2 forward until it presses against stitch width lever 3.**
- 4.4.3 **In this position use a screwdriver to turn hinge stud 4 until the locking lever has the right amount of play and then tighten clamp screw 1 (when at rest, locking lever 2 should be more or less parallel to stitch width lever 3).**
- 4.4.4 Check this adjustment (see "Correct setting").

5 Adjusting the needle in the needle hole (sideways)

Correct setting:

When the stitch width lever is turned to "0" and the needle position lever is in its central position the needle should enter the needle hole exactly in the middle (sideways).

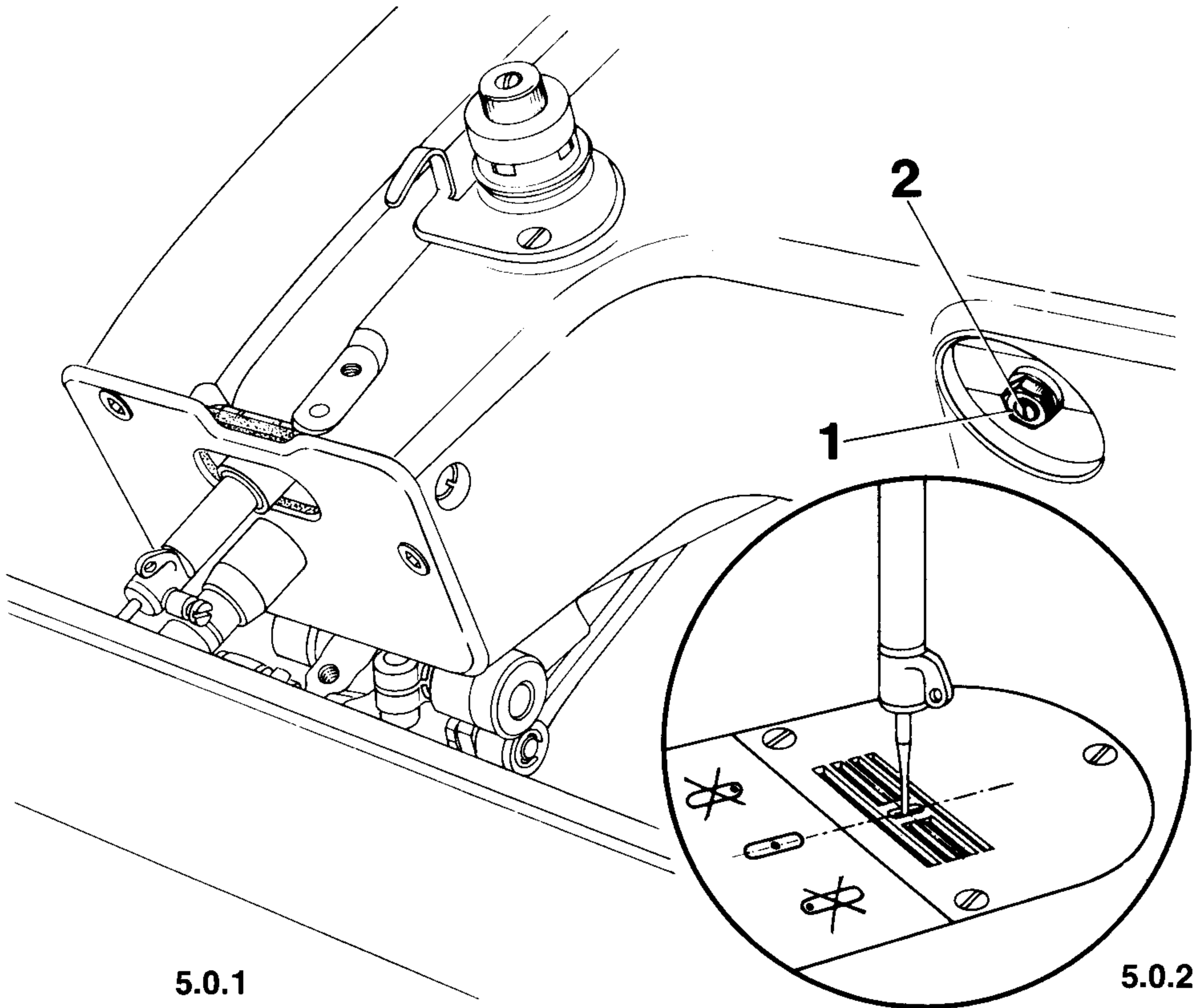

- 5.1 Turn the needle position lever to its central position and the stitch width lever to "0".
- 5.2 Bring the needle bar to b.d.c.
- 5.3 Loosen jam nut 1.
- 5.4 **Turn eccentric stud 2 until the needle is centred in the needle hole sideways.**
- 5.5 In this position tighten eccentric stud 2 with nut 1.
- 5.6 Check this adjustment (see "Correct setting").
- 5.7 Replace the plastic plugs on the underside of the arm.

Correct setting:

When the needle bar rises from the bottom position on the right of its throw to t.d.c. (pin in hole 2) it should not move to the side when the stitch width lever is moved to and fro.

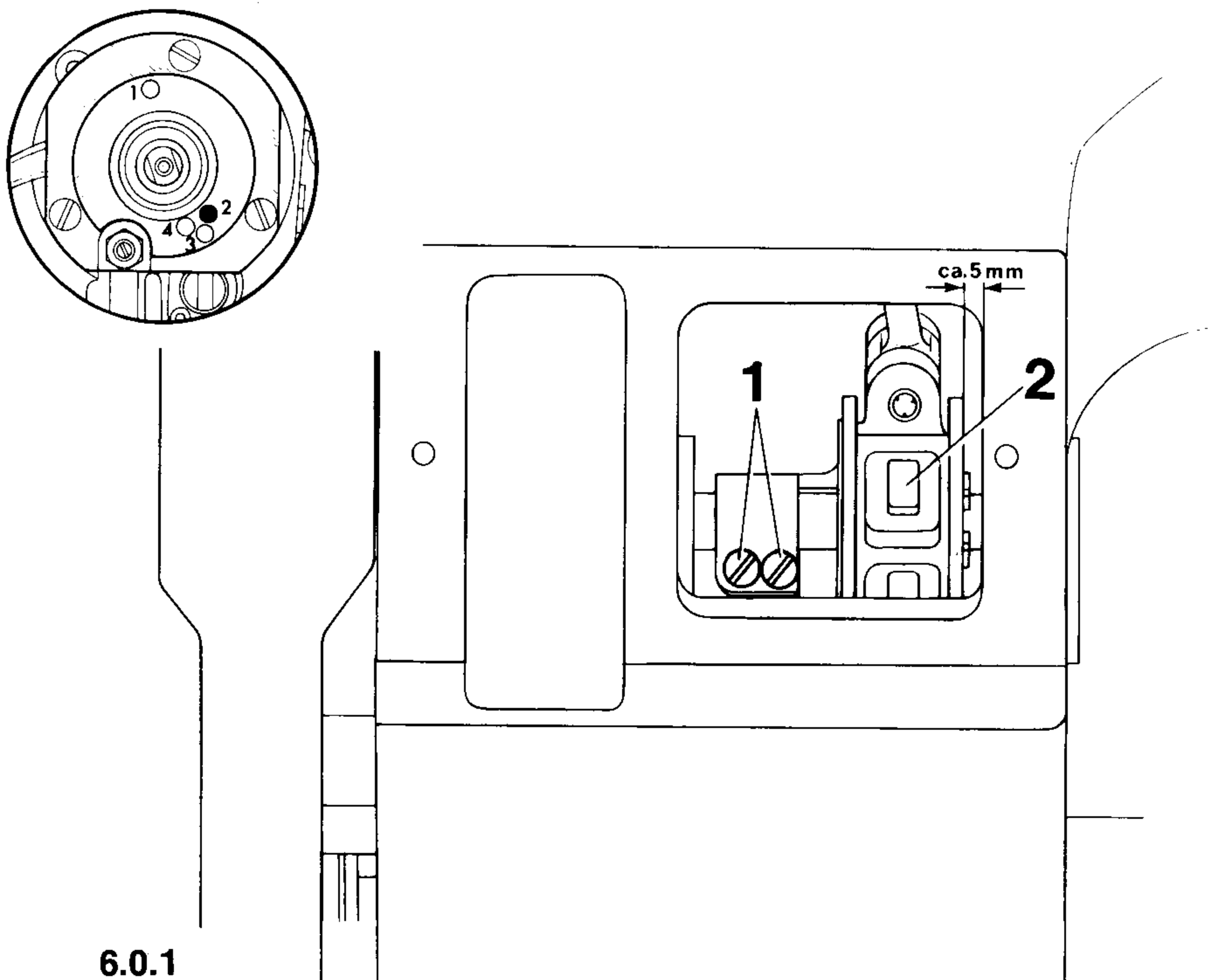

6.0.1

- 6.1 Unscrew the cover plate of the zigzag eccentric housing (do not pull the needle bar oil wick out of the hole in the gasket of the cover plate).
- 6.2 Drain the oil from the zigzag eccentric housing.
- 6.3 Loosen screws 1 of zigzag eccentric 2 just enough to allow the eccentric to be turned on its shaft against strong resistance.
- 6.4 Bring the needle bar from the bottom position on the right of its throw to t.d.c.
- 6.5 Insert cylindrical pin in hole "2" of the bearing plate (to block the machine).
- 6.6 Move eccentric 2 sideways on its shaft until there is a clearance of about 5 mm between it and the right wall of the casting.
- 6.7 **Turn eccentric 2 on its shaft until the needle bar stops vibrating when the stitch width lever is moved to and fro.**
- 6.8 Check this adjustment (see "Correct setting").
- 6.9 Remove cylindrical pin from hole "2" of the bearing plate.
- 6.10 Screws 1 are still loose.

Needle position “left, centre, right”

Correct setting:

When the stitch width lever is set at “0” the needle should enter the needle hole in the centre.
When the maximum stitch width is set the right and left positions of the needle in the needle hole should be equidistant from the centre (Fig. 7.0.2).

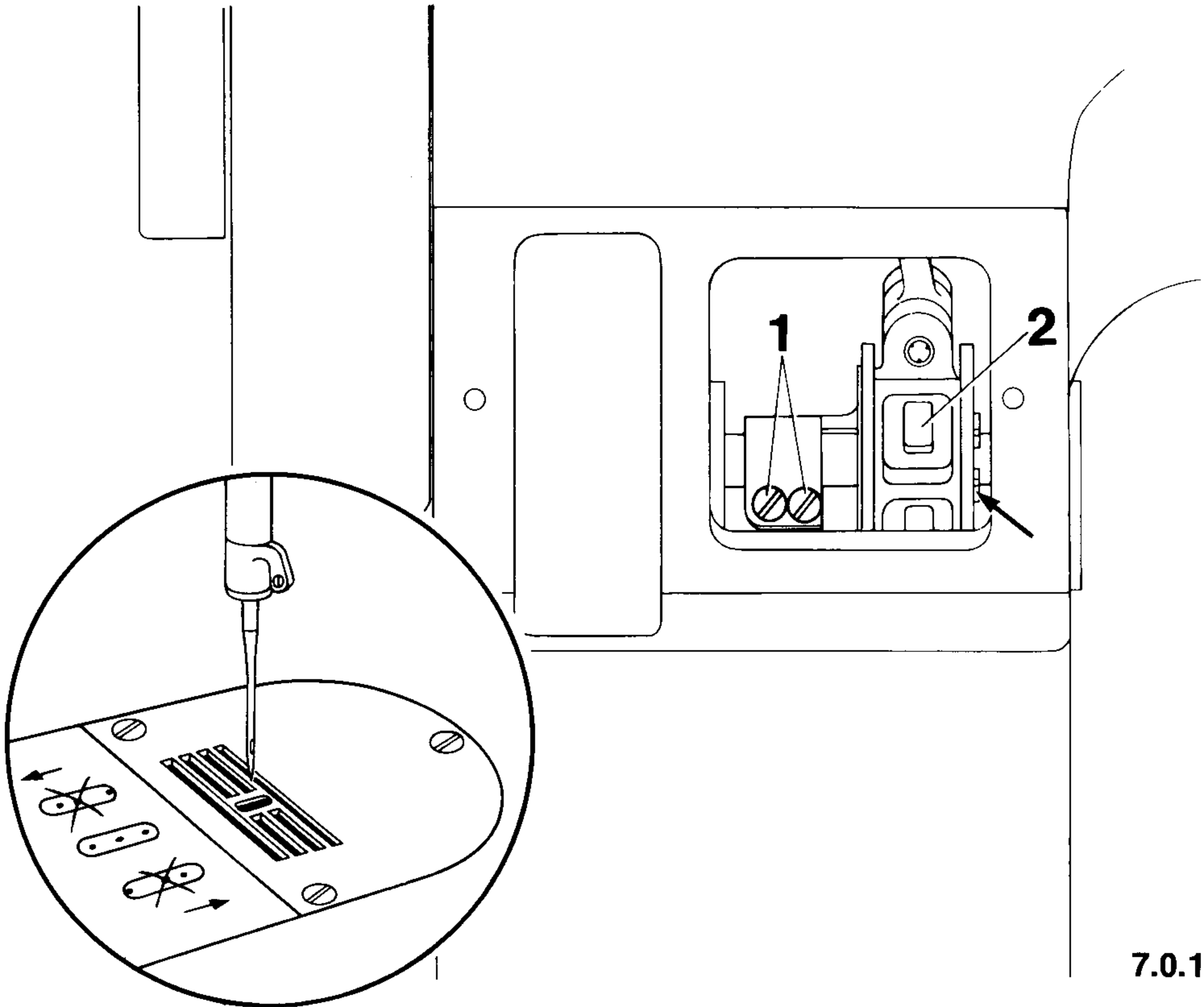
**7.0.2****7.0.1**

- 7.1 Turn needle position lever to its “central” position and the stitch width lever to “0”.
- 7.2 Place a piece of white paper on the needle plate and hold it in position.
- 7.3 Turn the balance wheel in its normal direction of rotation and let the needle pierce the paper.
- 7.4 Raise the needle again a little and hold the paper in position.
- 7.5 Turn the stitch width lever to the “maximum” stitch width.
- 7.6 Turn the balance wheel in its normal direction of rotation and let the needle pierce the paper again.
- 7.7 Remove the paper from under the needle and turn the balance wheel one complete turn.
- 7.8 Turn stitch width lever to “0” again.
- 7.9 Place the piece of paper under the needle again and position it so that the needle pierces the first hole exactly as before.

- 7.10 Making sure that the needle point is not in the paper, turn the stitch width lever to “maximum” and let the needle pierce the paper again.
- 7.11 **Move needle vibrating eccentric 2 in the direction in which the two outer needle punctures must be moved in order to obtain a symmetrical stitch pattern; make sure that the eccentric is not rotated in the process.**
- 7.12 In this position tighten screws 1 and push the circlip (see arrow in Fig. 7.0.1) up against the eccentric.
- 7.13 Check this adjustment (see “Correct setting”).

Correct setting:

The left and right throws of the needle should be the same both at the widest stitch setting and at the left and right needle positions.

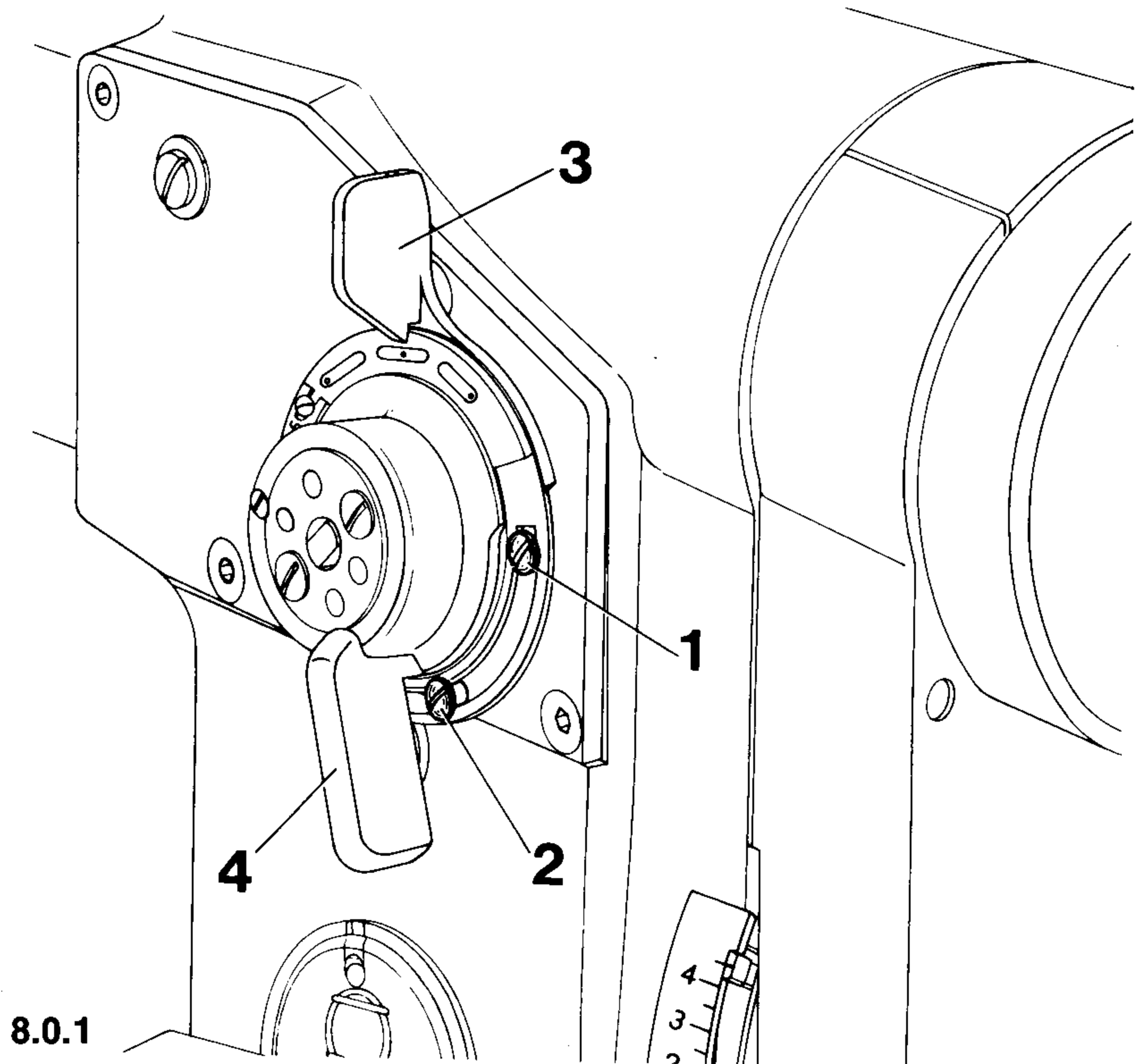

8.0.1

- 8.1 Loosen screws 1 and 2.
- 8.2 Turn needle position lever 3 to its "central" position and stitch width lever 4 to the "maximum" stitch width.
- 8.3 Turn the balance wheel in its normal direction of rotation until the descending needle is positioned above the left end of the needle hole.
- 8.4 Place a piece of white paper over the needle hole and fix it in position with adhesive tape.
- 8.5 Turn the balance wheel in sewing direction until the needle pierces the paper.
- 8.6 Turn the balance wheel in the opposite direction and let the needle pierce the paper again.
- 8.7 Turn stitch width lever 4 to "0" and push needle position lever 3 to the right until the point of the needle is positioned exactly above the hole last made in the paper.
- 8.8 **In this position push screw 2 against its stop and tighten it firmly.**
- 8.9 Push needle position lever 3 to the left until the point of the needle is positioned exactly above the left hole in the paper.
- 8.10 **In this position push screw 1 against its stop and tighten it firmly.**
- 8.11 Check this adjustment (see "Correct setting").
- 8.12 If necessary take the needle out of the needle bar.

Correct
setting:

When the "0" marks on the scale rings of milled wheels 1 are in line with graduation mark 4, guide pin 2 should be centred in its slot.

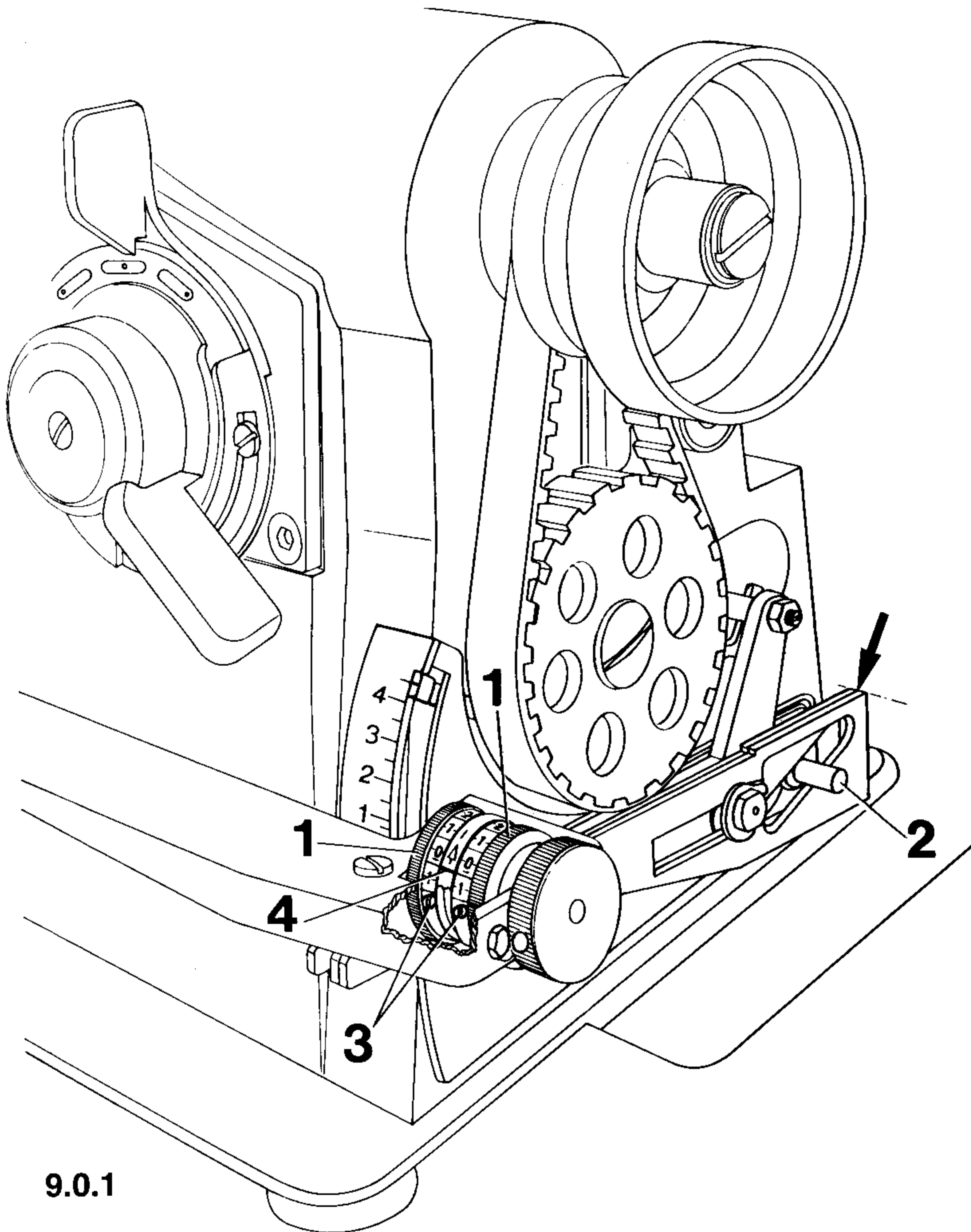

- 9.1 Unscrew the belt guard.
- 9.2 **Turn both milled wheels 1 until guide pin 2 is centred in its slot; the ends of both racks should now be in line (see arrow).**
- 9.3 Loosen screws 3.
- 9.4 **Turn both scale rings until the "0" marks are opposite graduation mark 4.**
- 9.5 In this position tighten screws 3 firmly.

Correct setting:

When the machine is set for the maximum stitch length the reverse-feed control should be in its highest position. Also stop lug 9 of clamp crank 8 should be up against the top actuating shaft.

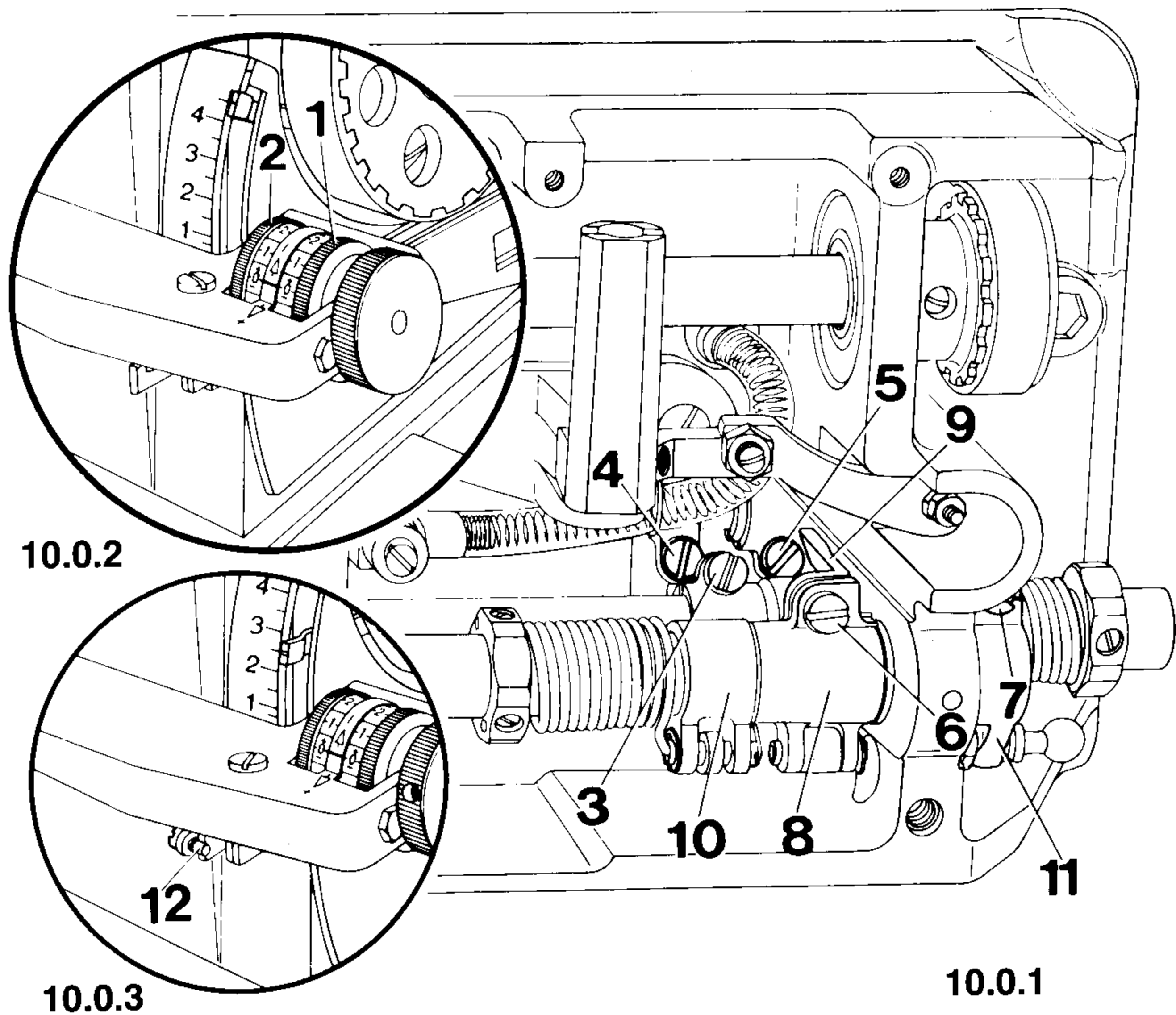

- 10.1 On machines with maximum stitch length N 24 unscrew screw 12 and remove the needle plate.
- 10.2 Set wheels 1 and 2 to "0".
- 10.3 Loosen screws 3, 4, 5, 6 and 7.
- 10.4 Set the machine for the maximum stitch length and push the reverse-feed control up as far as it will go.
- 10.5 **Bring stop lug 9 of clamp crank 8 to rest against the top actuating shaft.**
- 10.6 In this position tighten screws 5 and 6.
- 10.7 Turn clamp crank 10 until it is parallel with crank 8.
- 10.8 In this position tighten screws 3 and 4.
- 10.9 Turn clamp crank 11 until it is parallel with the bedplate.
- 10.10 In this position tighten screw 7.
- 10.11 Check this adjustment (see "Correct setting").
- 10.12 On machines with maximum stitch length N 24 replace needle plate and screw 12.

Correct
setting:

When the stitch length is set at "0" indicator 4 should be exactly opposite mark "0" on the scale.

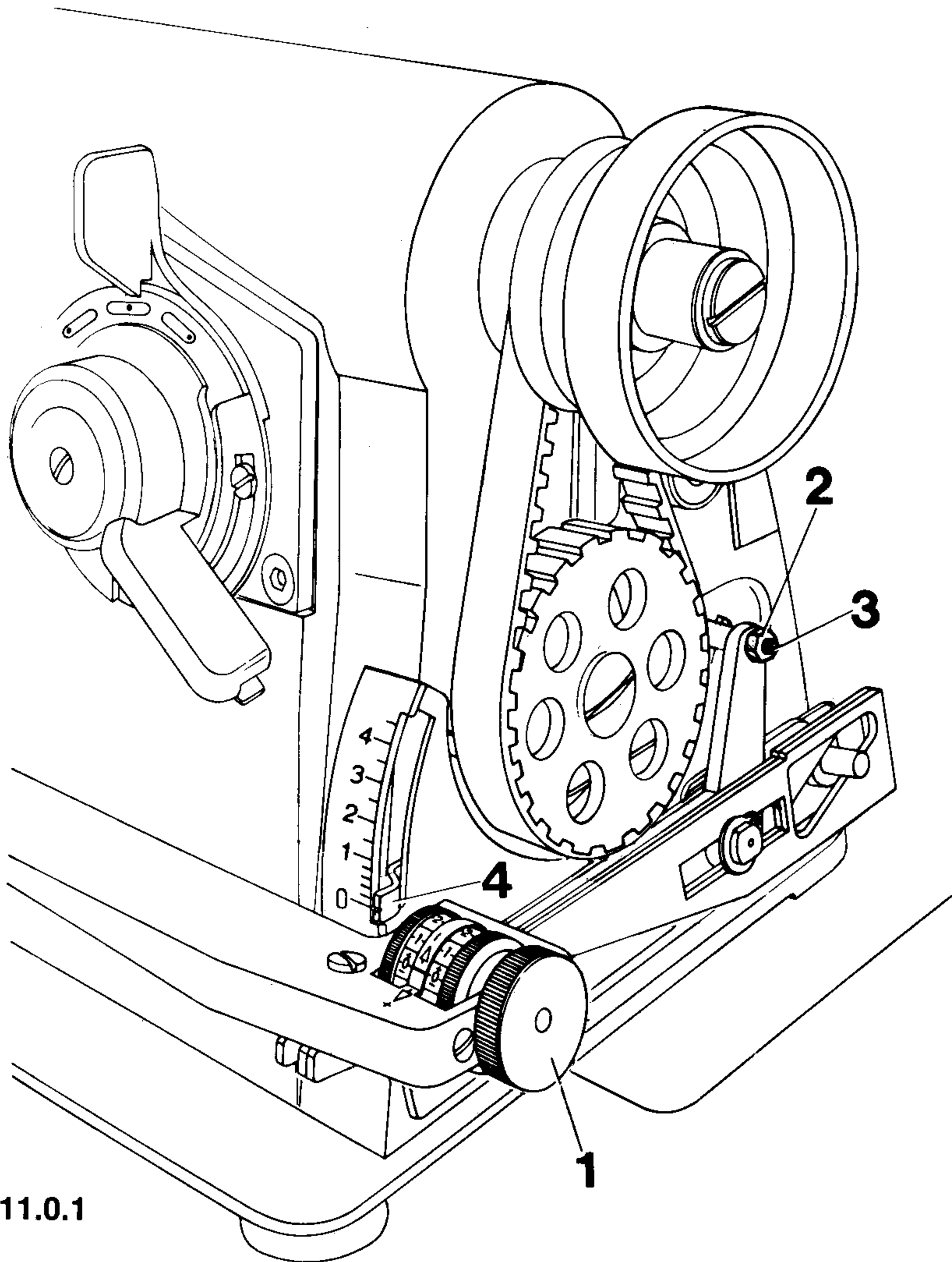

11.0.1

- 11.1 Turn milled wheel 1 forwards as far as it will go.
- 11.2 Loosen nut 2 and turn eccentric stud 3 until indicator 4 is exactly opposite mark "0".
- 11.3 In this position tighten nut 2.
- 11.4 Check this adjustment (see "Correct setting").

12

Zeroing the bottom feed

Correct setting:

When the stitch length is set at "0" the feed dog should not move forward when the balance wheel is turned.

12.1 Adjustment with **closed** gearcase.

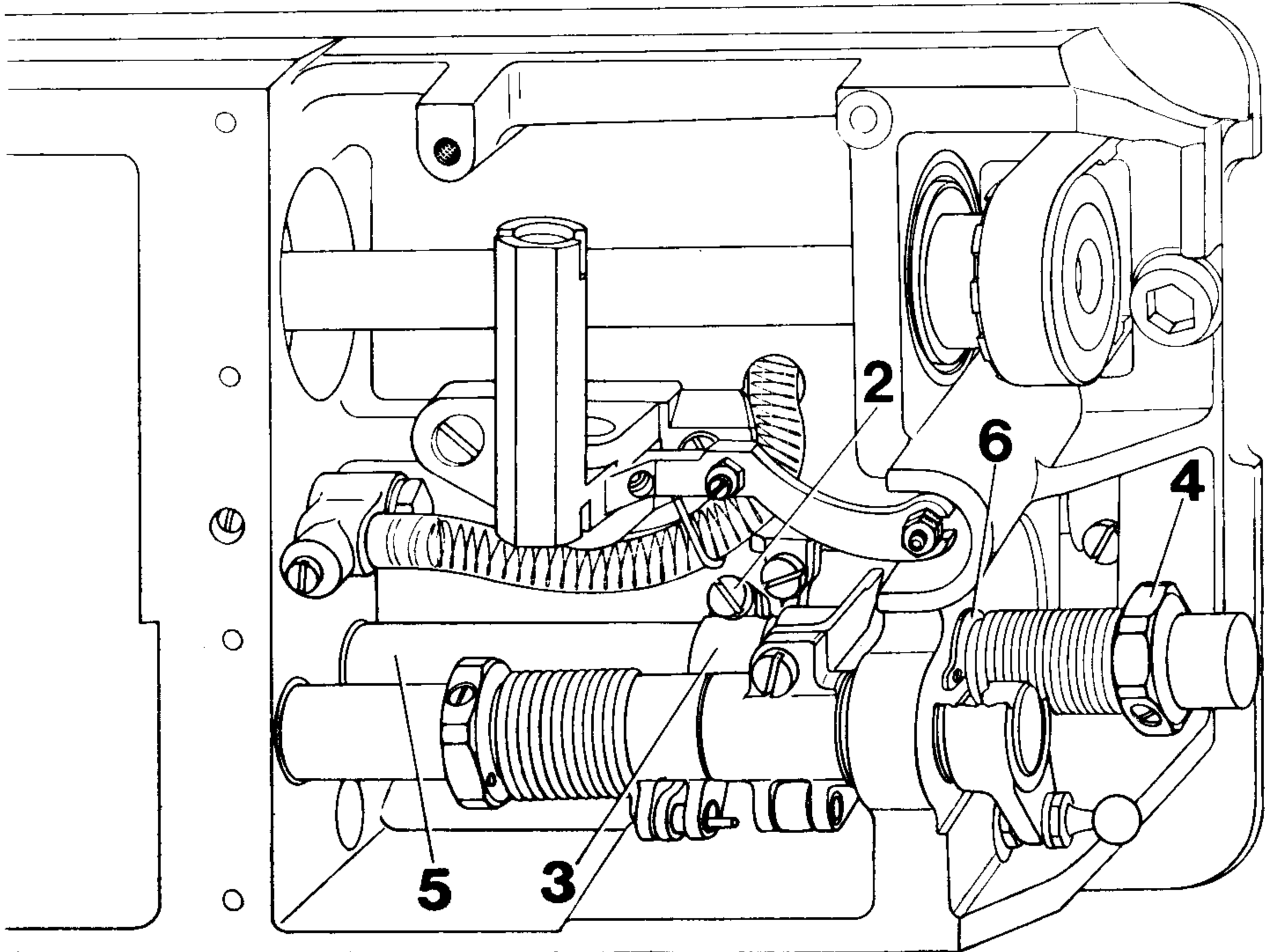

12.0.1

- 12.1.1 Set stitch length at "0".
- 12.1.2 To make it easier to see when the feed dog is motionless insert a screwdriver in the slot of feed rock shaft crank 1 (Fig. 12.0.2).
- 12.1.3 Loosen clamp screw 2 of actuating crank 3 (Fig. 12.0.1).
- 12.1.4 Place a 27-mm wrench on hexagon torsion nut 4 and thus hold actuating shaft 5 firmly in position.
- 12.1.5 **Keep rotating the balance wheel and turn the wrench on the torsion nut until the feed dog stops moving forward.**
- 12.1.6 Hold the wrench in this position and, making sure that actuating crank 3 and circlip 6 are against the casting, tighten clamp screw 2.
- 12.1.7 Check this adjustment (see "Correct setting").

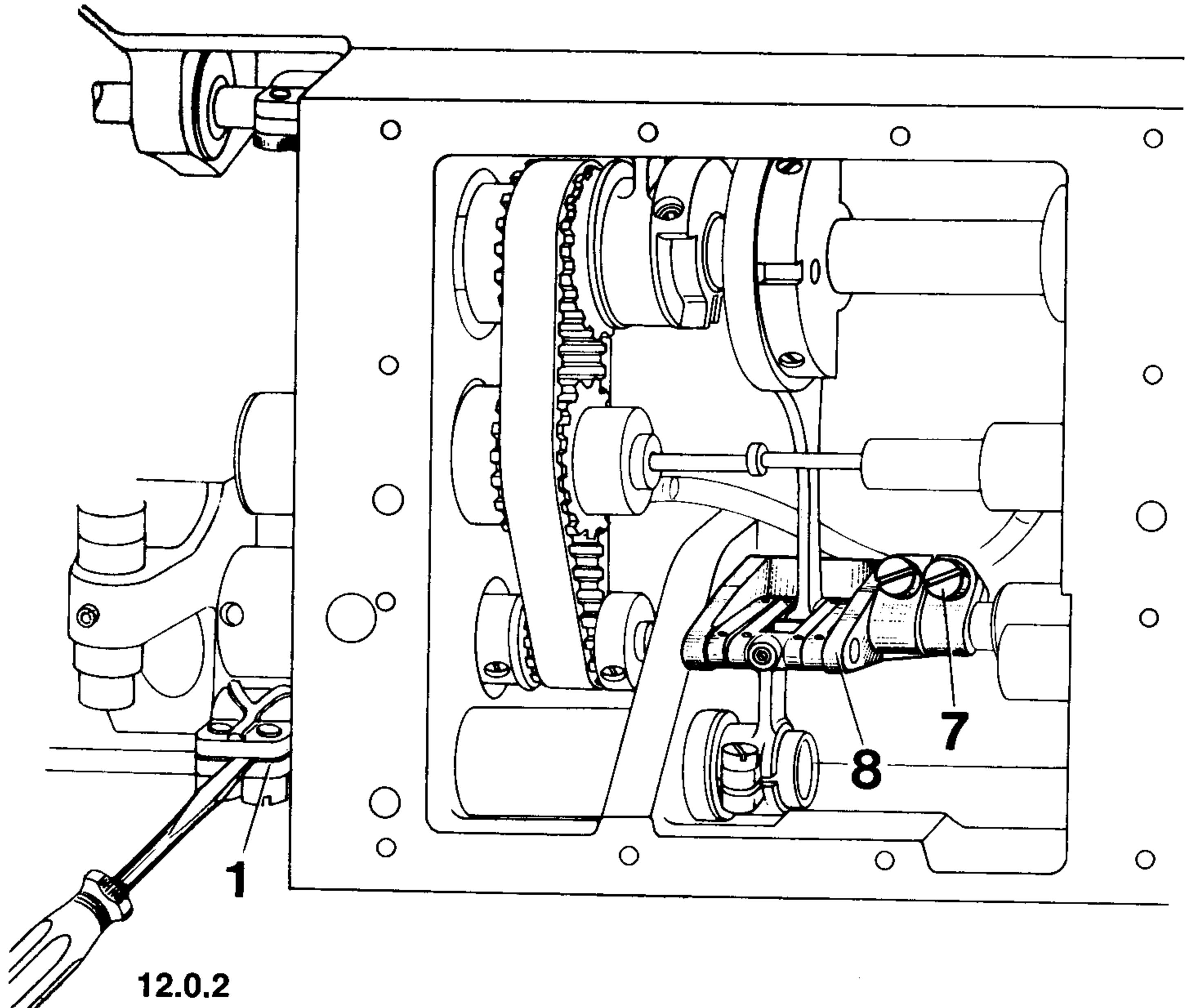

- 12.2.1 Remove gearcase cover on to the underside of the machine (collect any oil which runs out of the gearcase).
- 12.2.2 To make it easier to see when the feed dog is motionless insert a screwdriver in the slot of feed rock shaft crank 1.
- 12.2.3 Loosen clamp screw 7 just enough to allow crank 8 to be turned on its shaft against resistance.
- 12.2.4 **Turn the balance wheel and at the same time turn feed shaft crank 8 until the screwdriver and thus the feed dog is completely motionless.**
- 12.2.5 In this position tighten clamp screw 7.
- 12.2.6 Check this adjustment (see "Correct setting").

Correct
setting:

When the stitch length is set at "0" crank 2 of the top feed connecting lever should be horizontal.

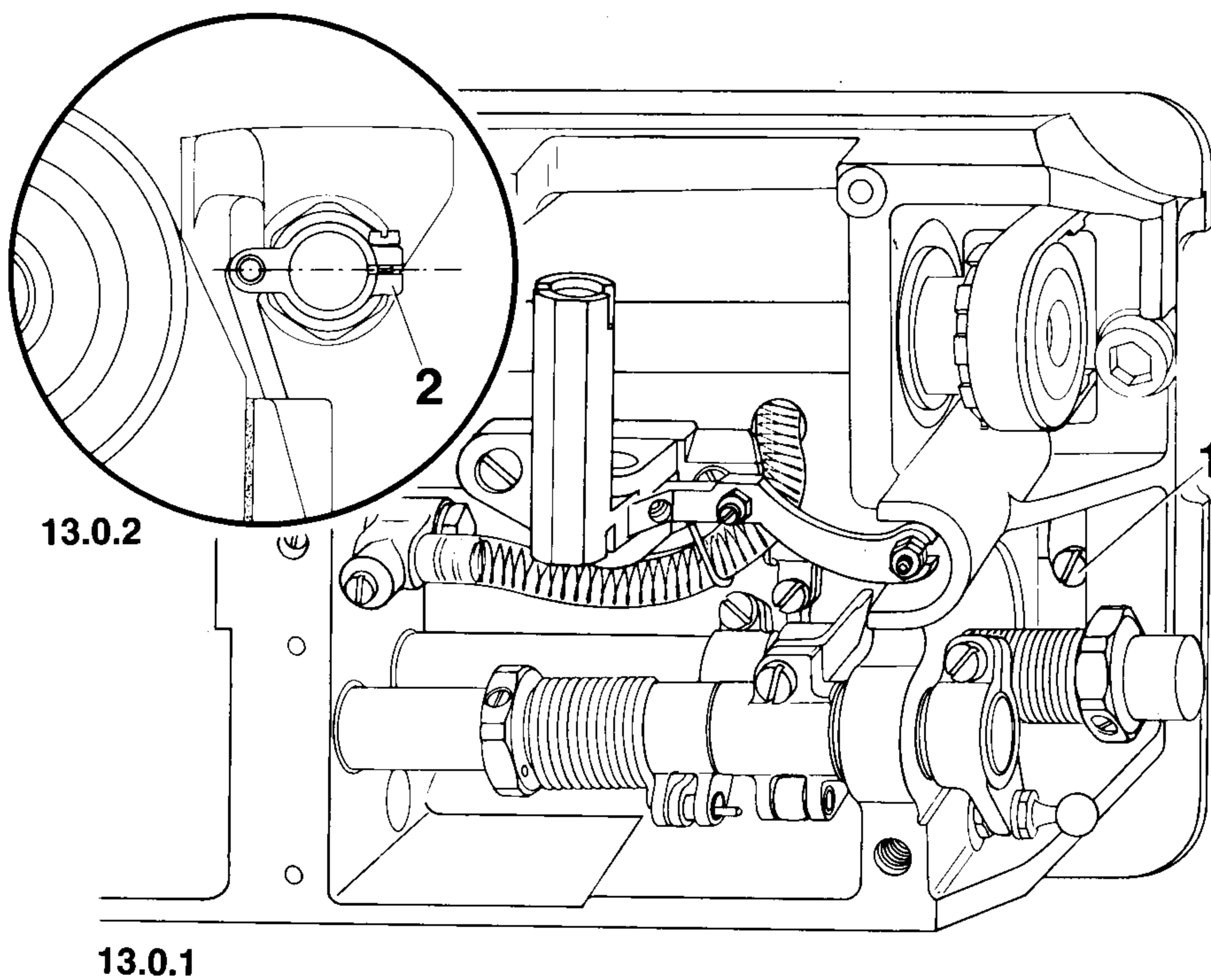

- 13.1 Set stitch length to "0".
- 13.2 Loosen screw 1.
- 13.3 Push top feed connecting rod until crank 2 is horizontal.
- 13.4 In this position tighten screw 1.

Correct
setting:

When differential adjustment wheels 1 and 2 are set at "0" and the stitch length is set at "0" the vibrating presser should not move when the balance wheel is turned.

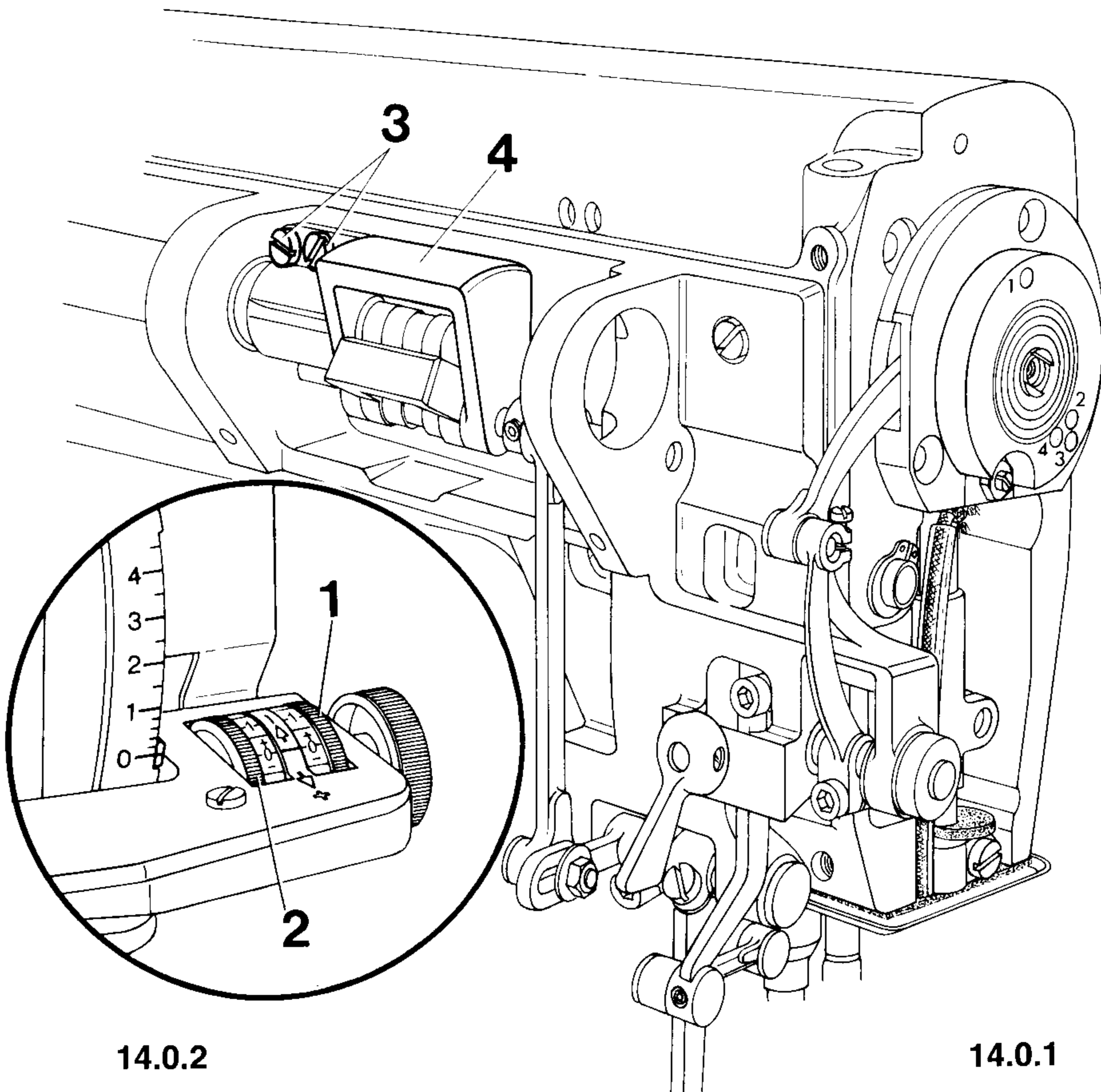

- 14.1 Set adjustment wheels 1 and 2 and the stitch length at "0".
- 14.2 Remove the four screws in the cover plate of crank 4.
- 14.3 Loosen screws 3 just enough to allow crank 4 to be turned against resistance.
- 14.4 **Adjust crank 4 so that when the balance wheel is turned the vibrating presser does not move.**
- 14.5 In this position tighten screws 3.
- 14.6 Check this adjustment (see "Correct setting").

15 **Adjusting the torsion springs**
 15.1 **Torsion spring of reverse-feed control**

Requirement: Presser foot raised.

Correct setting:

When the maximum stitch is set and differential adjustment wheels **1** and **2** are at "0" the reverse-feed control should automatically return to its top position after being pressed down.

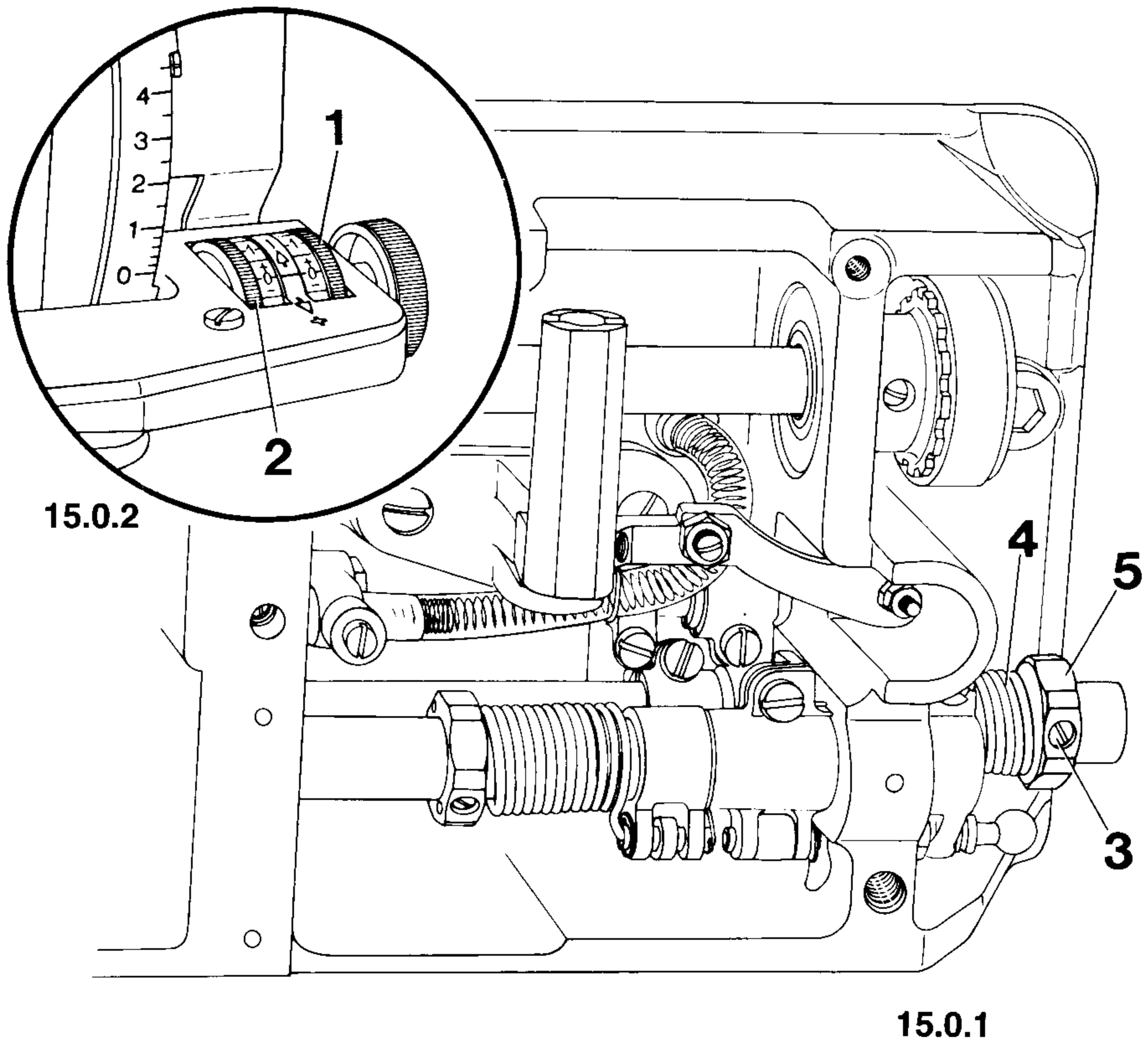

- 15.1.1 Raise presser foot by means of hand lever.
- 15.1.2 Set the machine for the maximum stitch length.
- 15.1.3 Set differential adjustment wheels **1** and **2** at "0".
- 15.1.4 Loosen screw **3** a little.
- 15.1.5 **Adjust the tension of torsion spring 4 with nut 5 until the reverse-feed control automatically returns to its top position after being pressed down.**
- 15.1.6 Tighten screw **3**.
- 15.1.7 Check this adjustment (see "Correct setting").

15.2 Torsion spring of differential feed actuating shaft

Requirement: Presser foot raised.

Correct setting:

When the stitch length is set at "0", the left differential adjustment wheel **2** at 4.5+, and the right differential adjustment wheel **1** at "0" guide pin **9** should contact the top edge of slot **10**.

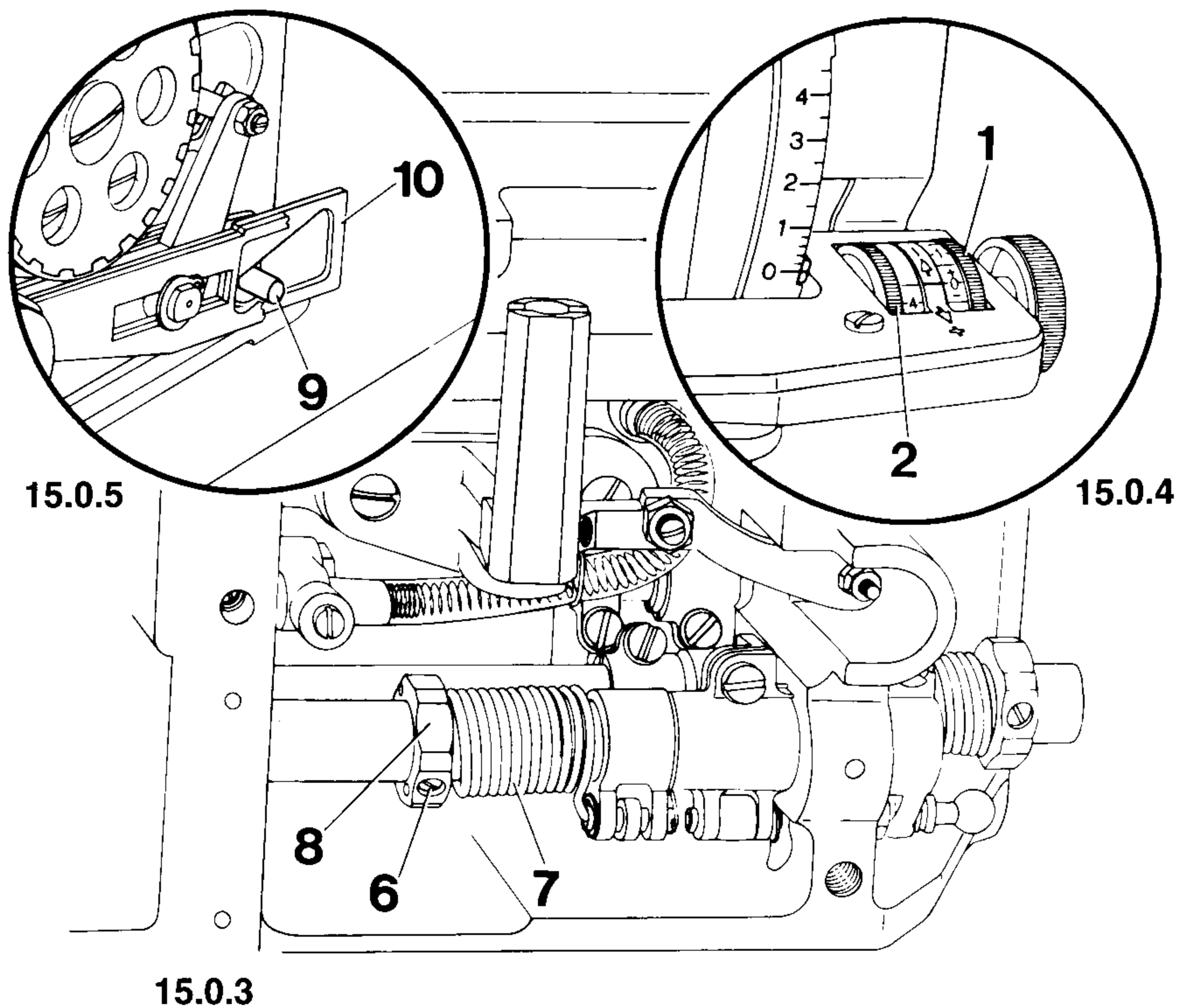

- 15.2.1 Raise the presser foot and set the stitch length at "0".
- 15.2.2 Set the left differential adjustment wheel **2** at 4.5+ and the right differential adjustment wheel **1** at "0" (Fig. 15.0.4).
- 15.2.3 Loosen screw **6**.
- 15.2.4 **Adjust the tension of torsion spring 7 with nut until guide pin 9 contacts to top edge of slot 10 (see arrow in Fig. 15.0.5).**
- 15.2.5 Tighten screw **6**.
- 15.2.6 Check this adjustment (see "Correct setting").

Correct setting:

When the machine is set for its longest stitch and the needle bar is positioned 1 mm beyond its t.d.c. (pin in hole 4) the feed dog should not move when the reverse-feed control is operated.

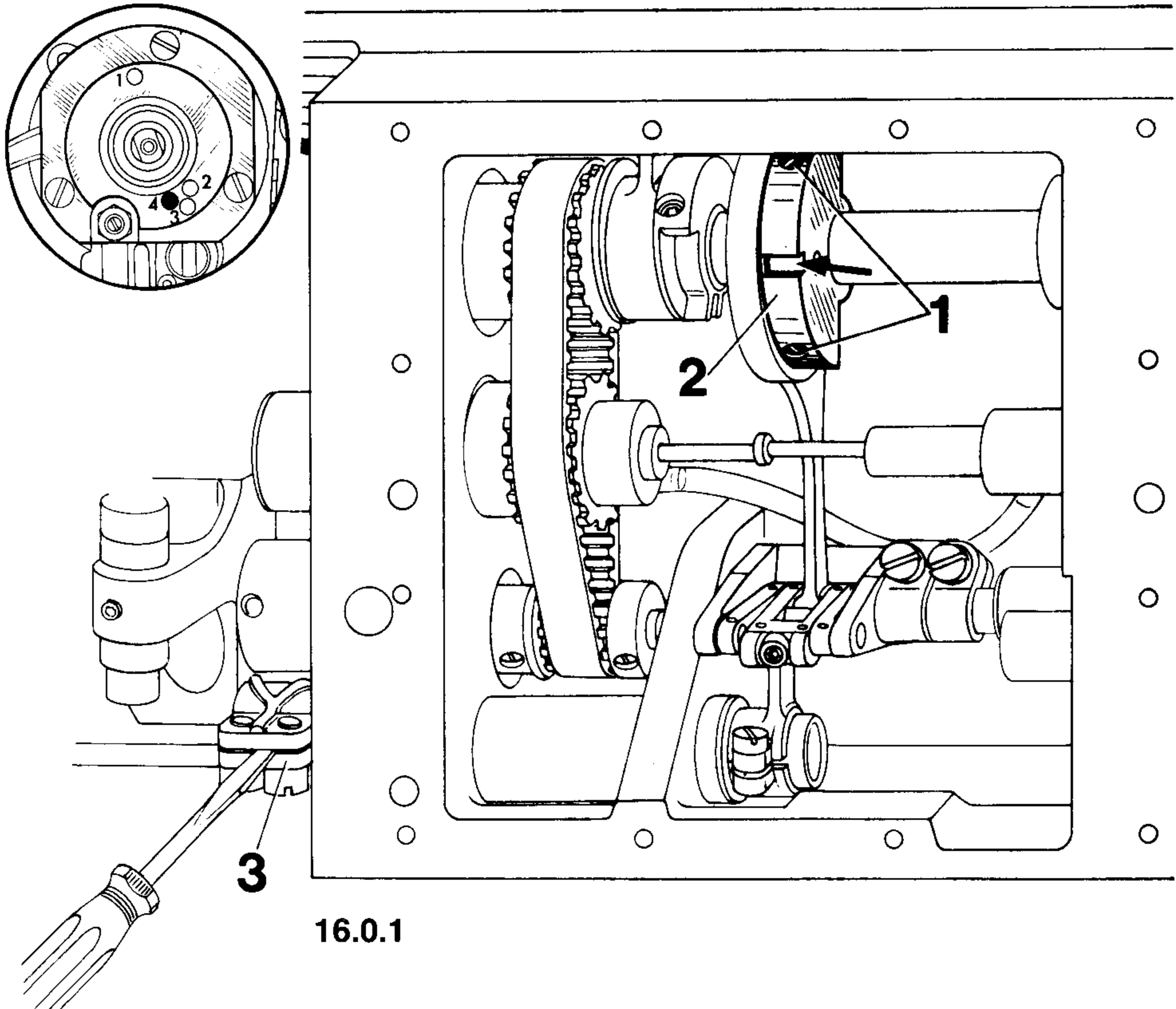

16.0.1

- 16.1 Turn the shaft to make screws 1 of feed driving eccentric 2 accessible and loosen them just enough for the eccentric to be turned against strong resistance.
- 16.2 Turn the balance wheel until the needle bar is positioned 1 mm beyond its t.d.c.
- 16.3 Insert the cylindrical pin in hole 4 of the bearing plate (to block the machine).
- 16.4 Set the machine for its longest stitch.
- 16.5 **Move the reverse-feed control up and down and turn feed driving eccentric 2 until the notch on the eccentric is visible and the screwdriver in feed rock shaft crank 3 is completely motionless.**
- 16.6 In this position, making sure that the feed driving eccentric is not moved along the shaft, tighten one of the screws 1.
- 16.7 Remove the cylindrical pin from the hole of the bearing plate.
- 16.8 Tighten the other screw 1.
- 16.9 Check this adjustment (see "Correct setting").
- 16.10 Remove the screwdriver from feed rock shaft crank 3.

Correct setting:

When the stitch length is set at "0" and the needle bar is positioned **0.25 mm beyond its t.d.c.** (pin in hole **3**) feed lifting shaft crank **3** should be at its b.d.c.

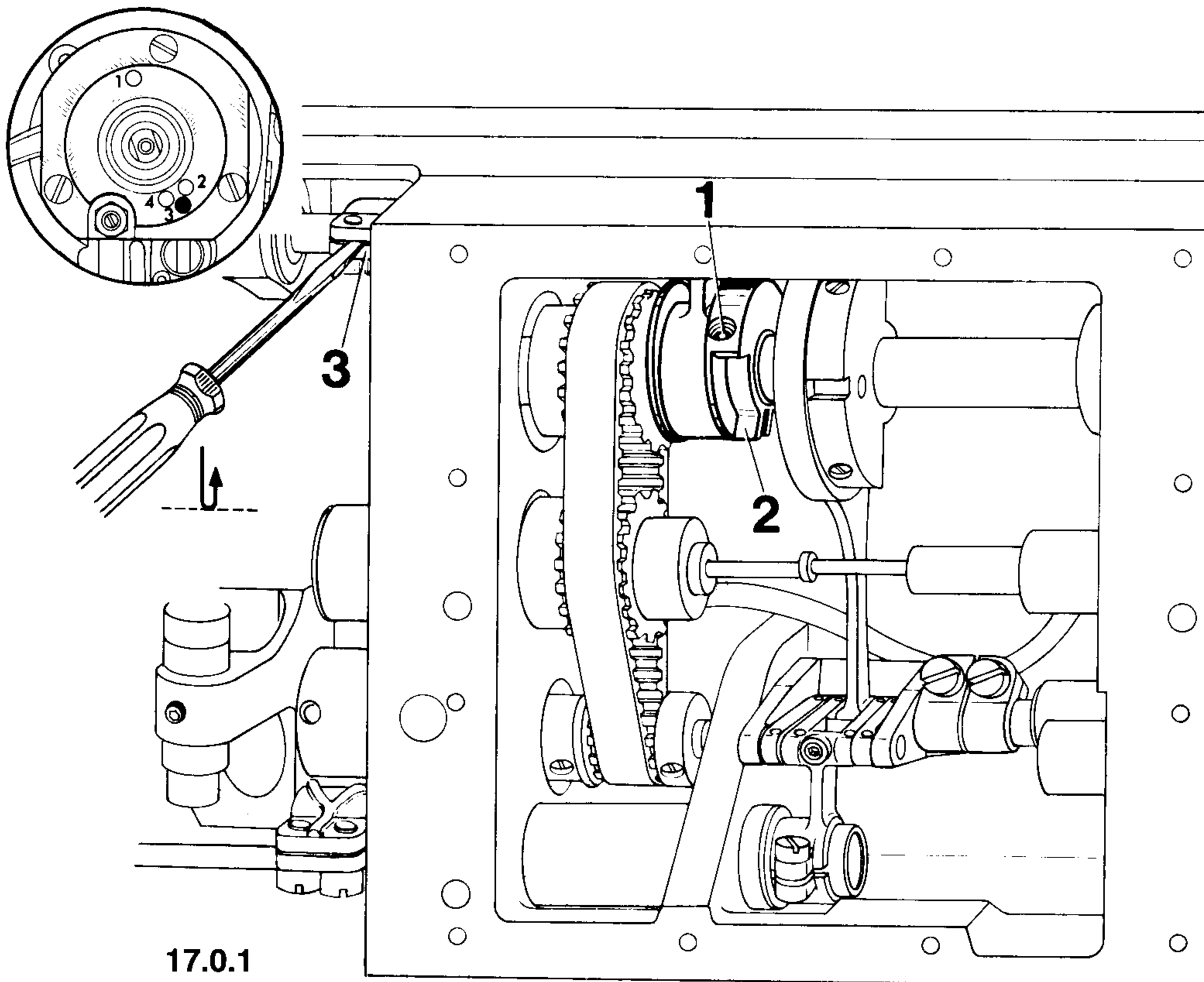

17.0.1

- 17.1 Set the stitch length at "0".
- 17.2 Loosen screws **1** in feed lifting eccentric **2**.
- 17.3 Turn the balance wheel until the needle bar is positioned **0.25 mm beyond its t.d.c.**
- 17.4 Insert the cylindrical pin in hole "**3**" of the bearing plate (to block the machine).
- 17.5 To make it easier to recognise the b.d.c. position insert a screwdriver in the slot of lifting crank **3**.
- 17.6 **Turn feed lifting eccentric **2** on its shaft until the screwdriver in feed lifting shaft crank **3** is at its b.d.c.** (see arrow in Fig. 17.0.1).
- 17.7 In this position, making sure that feed lifting eccentric **2** does not move along the shaft, tighten the accessible screw **1**.
- 17.8 Remove the cylindrical pin from the hole of the bearing plate.
- 17.9 Tighten the second screw **1**.
- 17.10 Check this adjustment (see "Correct setting").

Correct setting:

The driving belt should be tensioned so that the gears have no backlash, but the machine does not bind.

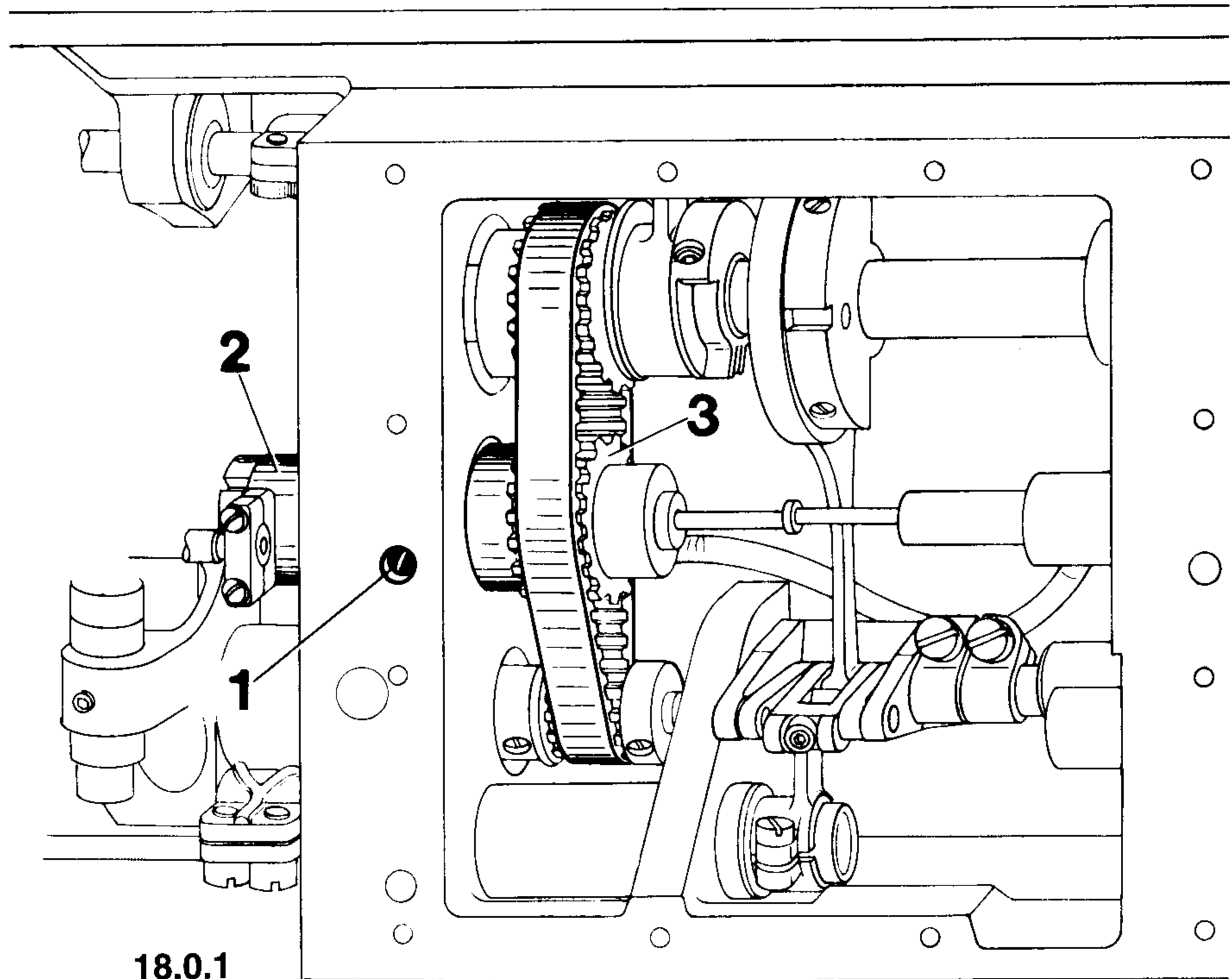

18.0.1

- 18.1 Loosen screw 1.
- 18.2 Move eccentric bushing 2 until the driving belt is positioned in the middle of the bobbin case opener driving gear.
- 18.3 **Making sure that eccentric bushing 2 is not moved, tension the driving belt by turning the eccentric bushing so that the gears have no backlash but the machine does not bind.**
- 18.4 In this position tighten screw 1.
- 18.5 Check this adjustment (see "Correct setting").

Adjusting the hook bearing bracket

Correct setting:

The hook shaft should contact both the vertical and horizontal surfaces of the hook bearing bracket gauge.

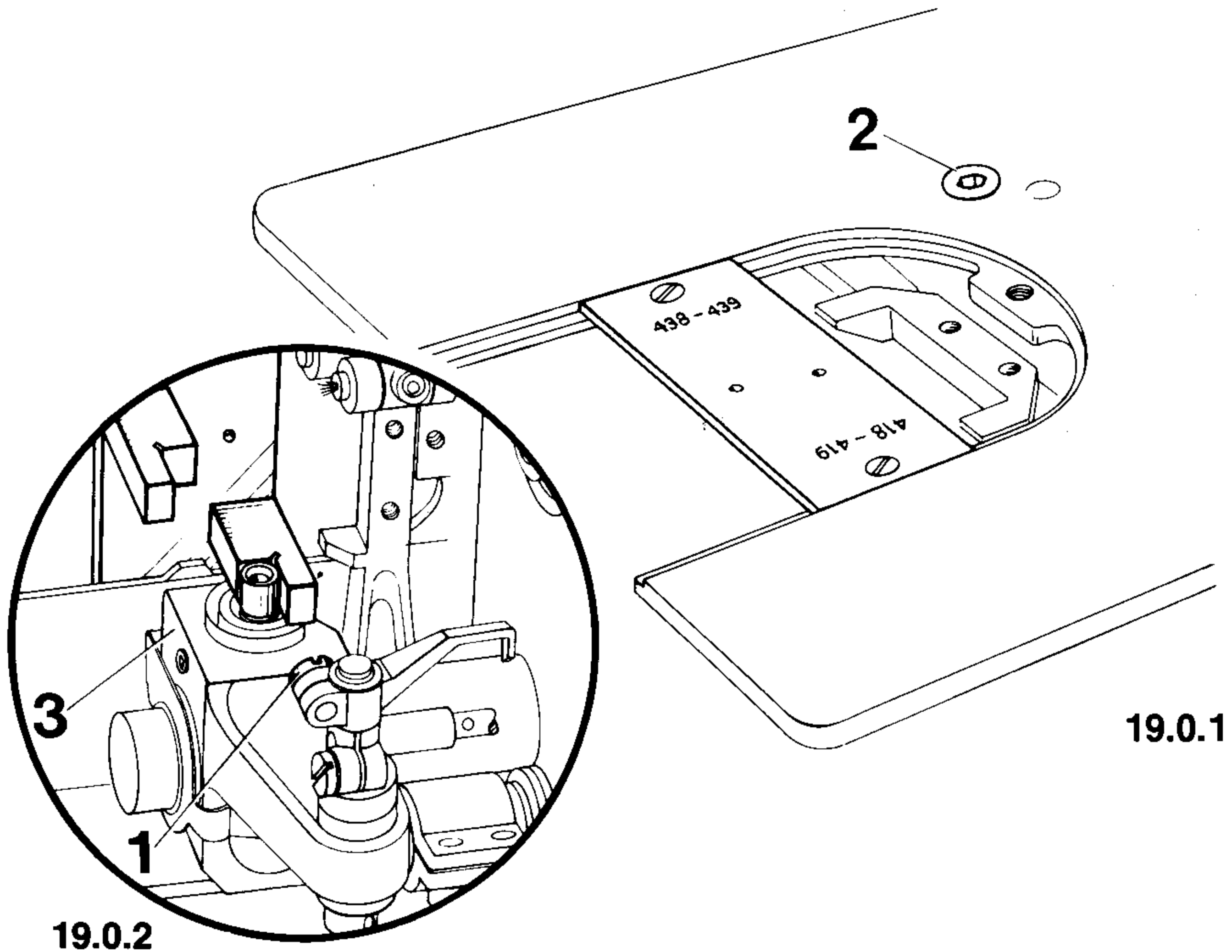

- 19.1 Remove bed slide, needle plate, feed dog and bobbin case position finger.
- 19.2 Loosen clamp screw 1 and swing the bobbin case opener to the right.
- 19.3 Loosen the two hook set screws and remove the sewing hook from its shaft.
- 19.4 Loosen allen screw 2 on the bedplate and release the taper key of hook bearing bracket 3 underneath this screw by tapping the head of the allen screw lightly with a hammer.
- 19.5 Screw on the hook bearing bracket gauge so that on Cl. 437 and 417 machines numbers 438-439 and 418-419 respectively can be read from the front (Fig. 19.0.1).
- 19.6 **By turning and moving hook bearing bracket 3 bring the hook shaft into contact with both the vertical and horizontal surfaces of the hook bearing bracket gauge.**
- 19.7 In this position tighten allen screw 2.
- 19.8 Unscrew and remove the hook bearing bracket gauge.

Correct
setting:

When the needle bar is at t.d.c. (pin in hole "2"), there should be a clearance of **19 mm** between needle point and needle plate.

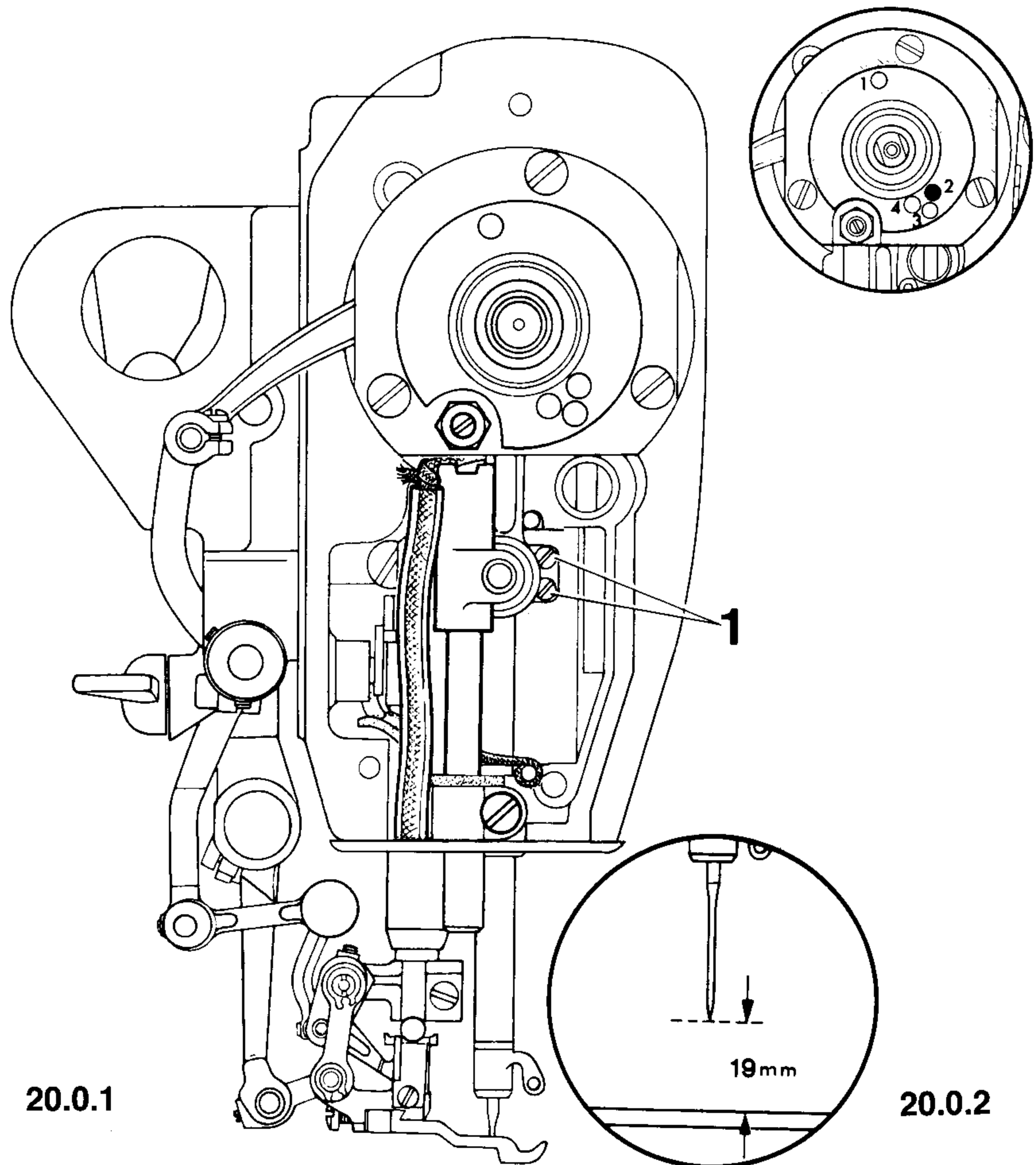

- 20.1 Bring the needle bar to t.d.c. and insert the cylindrical pin in hole "2" of the bearing plate.
- 20.2 Insert a needle and place the needle plate in the needle plate cutout.
- 20.3 Loosen screws 1 in the needle bar connecting stud.
- 20.4 **Adjust the needle bar vertically - without turning it - until there is a clearance of 19 mm between needle point and needle plate.**
- 20.5 In this position tighten screws 1.
- 20.6 Remove the needle plate again.

Correct setting:

When the hook is in contact with the oil distributor ring there should be a clearance of **0.4 mm** between the hook point and the middle of the clearance cut of the needle (Fig. 21.0.1).

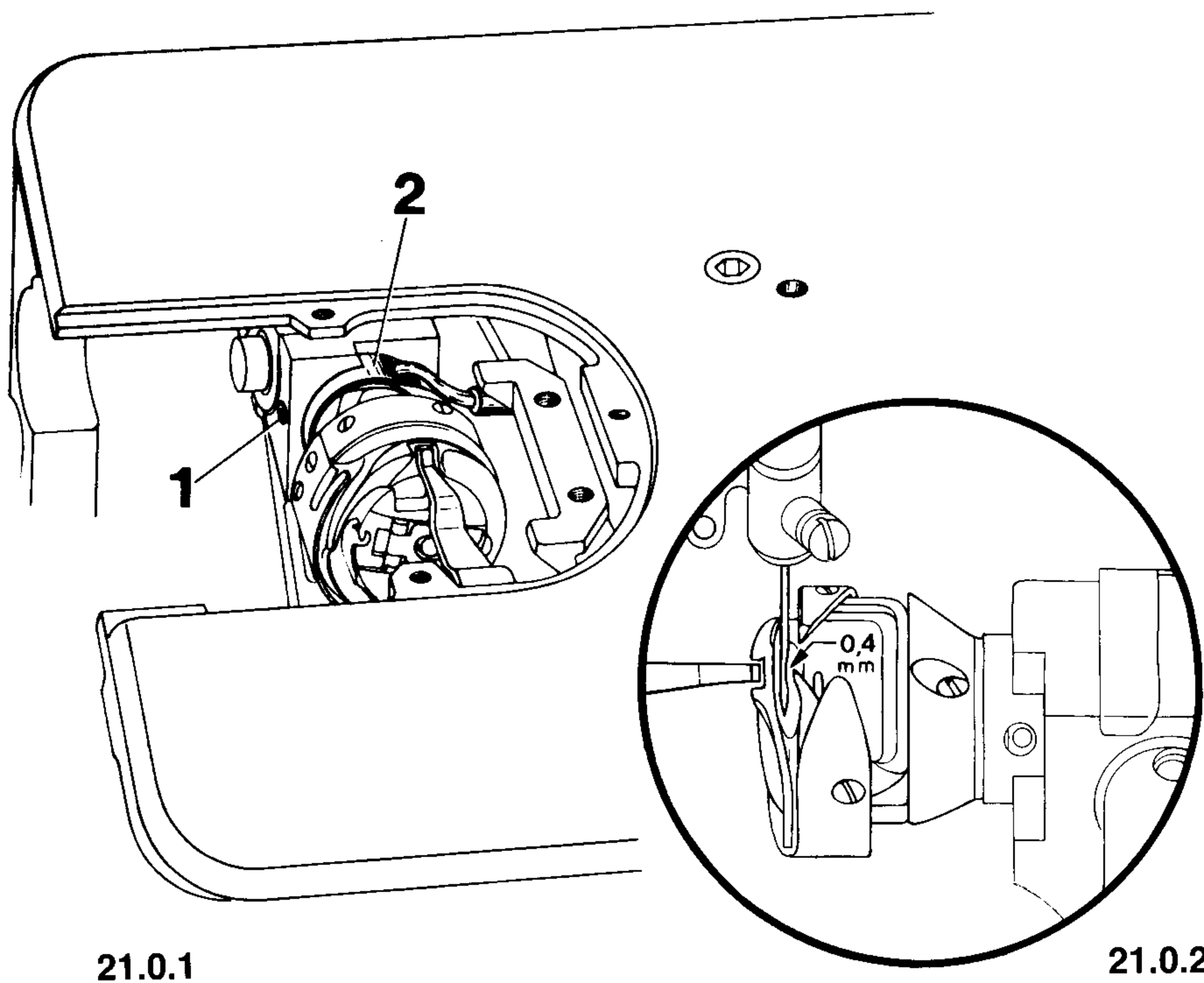

21.0.1

21.0.2

- 21.1 Set the stitch width lever at "0" and the needle position lever at its central position.
- 21.2 Place the sewing hook on the hook shaft.
- 21.3 Bring the needle bar to a position **2 mm** beyond b.d.c. but make sure the needle does not strike the sewing hook.
- 21.4 Loosen screw **1** of oil distributor ring **2**.
- 21.5 **Making sure that the hook is up against the oil distributor ring, move the oil distributor ring and the hook until there is a clearance of 0.4 mm between the hook point and the middle of the clearance cut of the needle (Fig. 21.0.2).**
- 21.6 In this position tighten screw **1**.
- 21.7 Check this adjustment (see "Correct setting").

Correct
setting:

Oil tube 2 should be in the hole of the oil distributor ring (see arrow in Fig. 22.0.1).

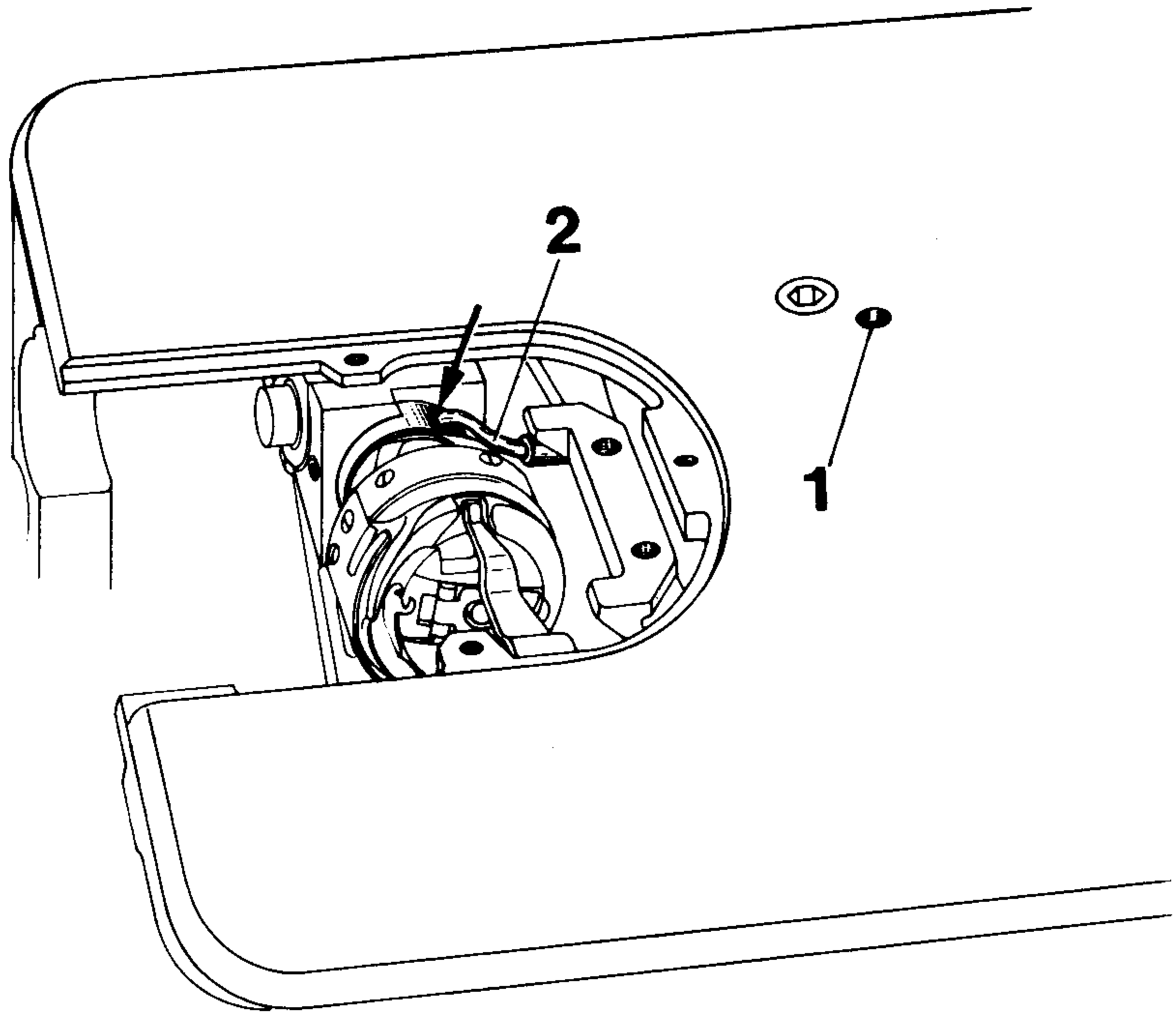

22.0.1

22.1

Loosen allen screw 1.

22.2

Place oil tube 2 in the hole of the oil distributor ring (see arrow in Fig. 22.0.1).

22.3

Tighten allen screw 1.

23 Hook timing and hook-to-needle clearance

Correct setting:

With the needle position lever in its central position, the stitch width lever at "0" and the needle bar at a position **2 mm** beyond b.d.c. (pin in hole "1") the hook point should be exactly opposite the centre line of the needle. Also, in this position, there should be a clearance of abt. **0.1 mm** between hook point and needle.

- 23.1 Set the stitch width lever at "0" and the needle position lever at its central position.
- 23.2 Bring the needle bar to a position **2.0 mm beyond b.d.c.**, making sure that the needle does not strike the sewing hook. Block the machine in this position by inserting the pin in hole "1" of the bearing plate.
- 23.3 Turn the sewing hook on its shaft until its point is opposite the centre line of the needle.
- 23.4 Adjust the hook laterally, however without turning it, until there is a clearance of **0.1 mm** between its point and the needle.
- 23.5 In this position, tighten the accessible hook set screw.
- 23.6 Screw on the bobbin case position finger so that it is positioned in the slot of the bobbin case base and that there is a clearance of **0.5 mm** between its front edge and the bobbin case base.
- 23.7 Pull the pin out of the hole in the bearing plate and tighten the second hook set screw.
- 23.8 Check this adjustment (see "Correct setting").

Correct setting:

With the stitch width lever at "0", the needle position lever at its left position and the hook point positioned exactly opposite the needle, the bottom edge of the hook point should be positioned **0.5 mm** above the top of the needle eye.

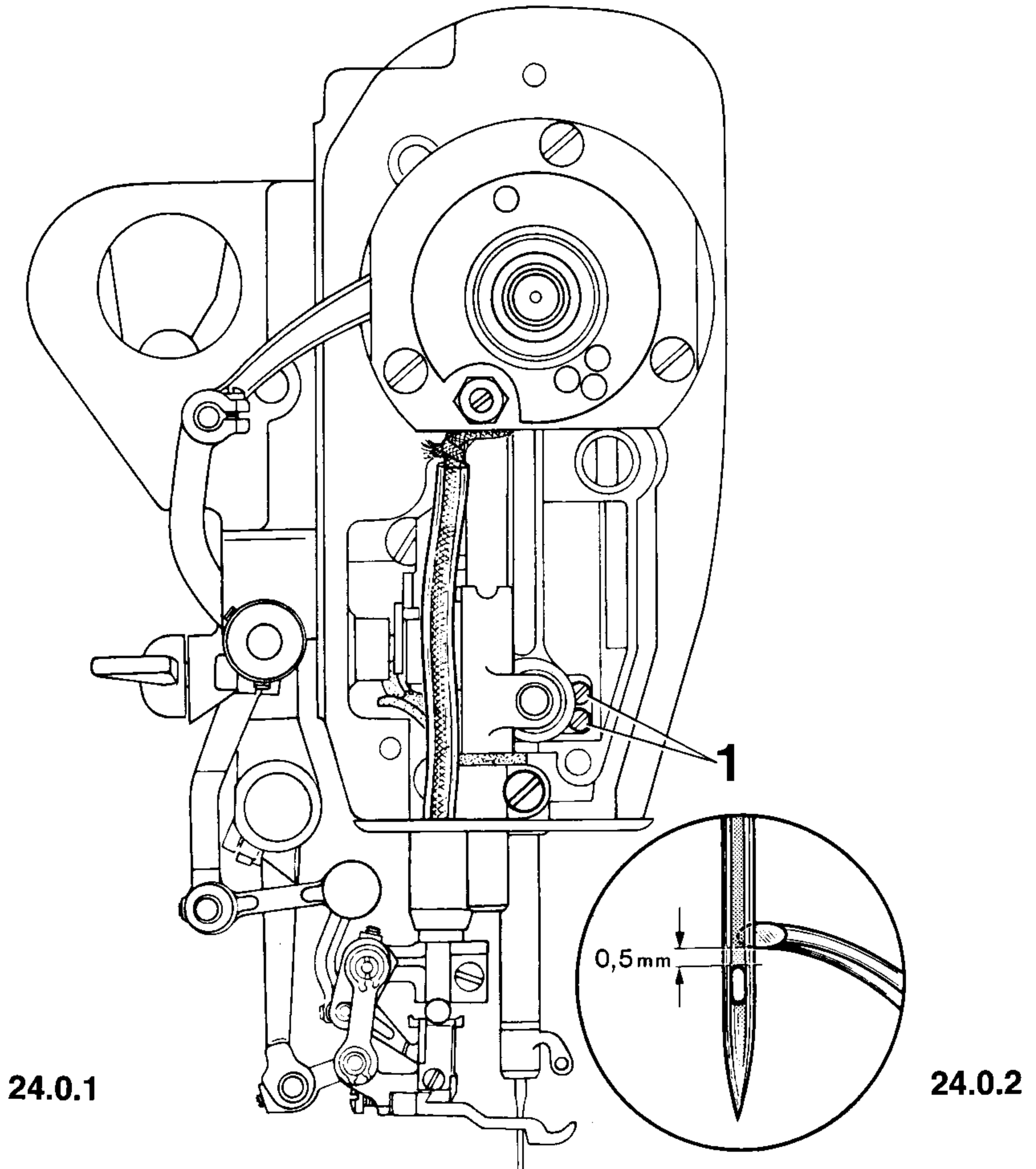

24.0.1

24.0.2

- 24.1 Set the stitch width lever at "0" and the needle position lever to its left position.
- 24.2 Turn the balance wheel until the hook point is exactly opposite the needle.
- 24.3 Loosen both clamp screws 1 of the needle bar connecting stud.
- 24.4 **Push the needle bar up or down until the hook point is positioned 0.5 mm above the top of the needle eye.**
- 24.5 In this position, tighten both screws 1, making sure that the thread guide of the needle holder faces the front (Fig. 24.0.1).

Correct setting:

When the needle bar is at b.d.c. the bottom edge of the slack thread control wire is in line with the top edge of the hole in the thread guide (Fig. 25.0.2).

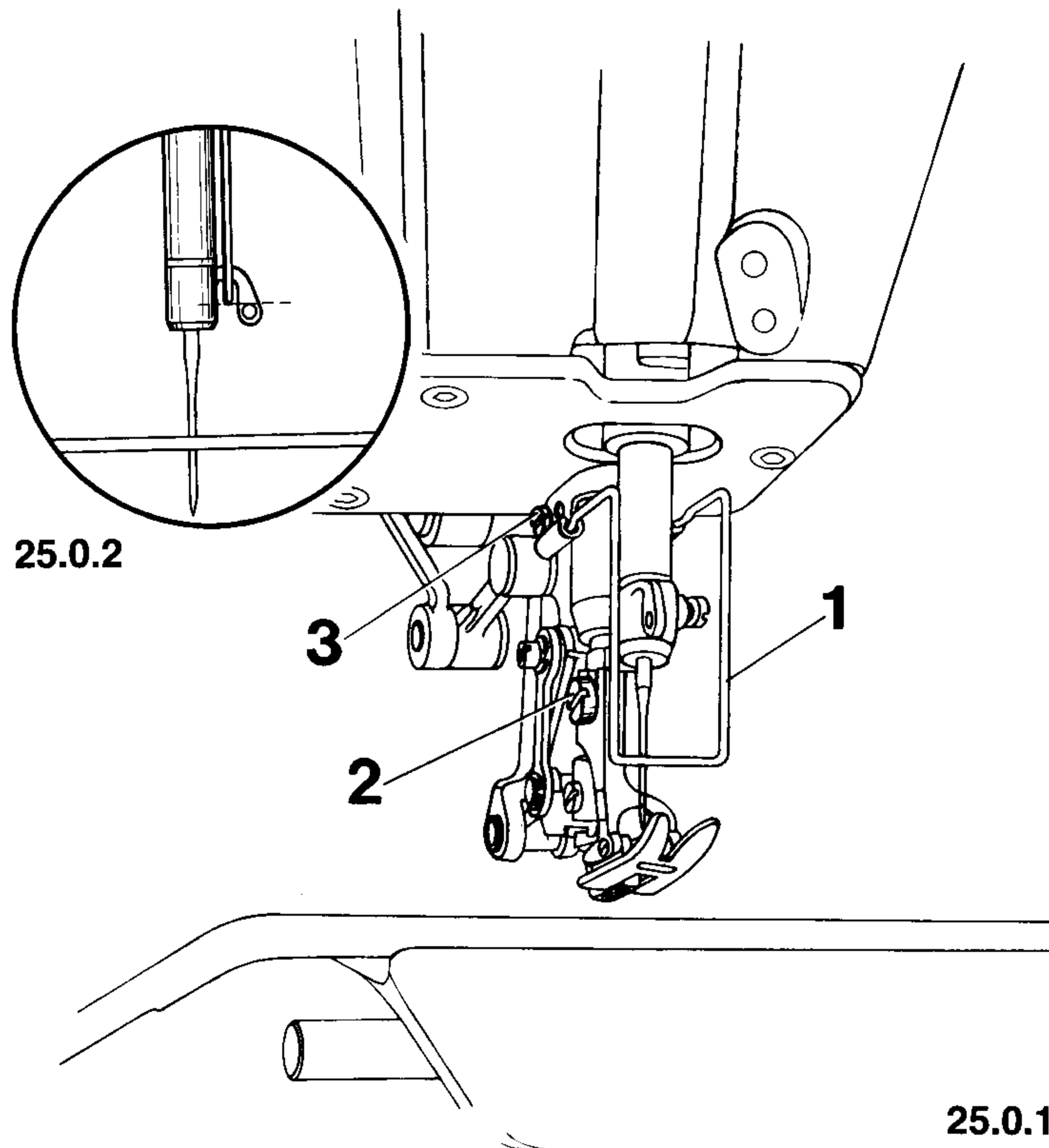

- 25.1 Push slack thread control wire **1** on bushing **2** and hold it in its position.
- 25.2 Bring the needle bar to b.d.c.
- 25.3 **Adjust the position of slack thread control wire **1** so that its bottom edge is in line with the top edge on the hole in the thread guide.**
- 25.4 In this position tighten screw **3**, making sure that slack thread control wire **1** is set parallel to the bedplate.
- 25.5 Check this adjustment (see "Correct setting").

Correct setting:

When the presser bar lifter is raised there should be a clearance of **7 mm** between presser foot and needle plate. Furthermore the needle should be centred exactly in the needle "hole" of the presser foot.

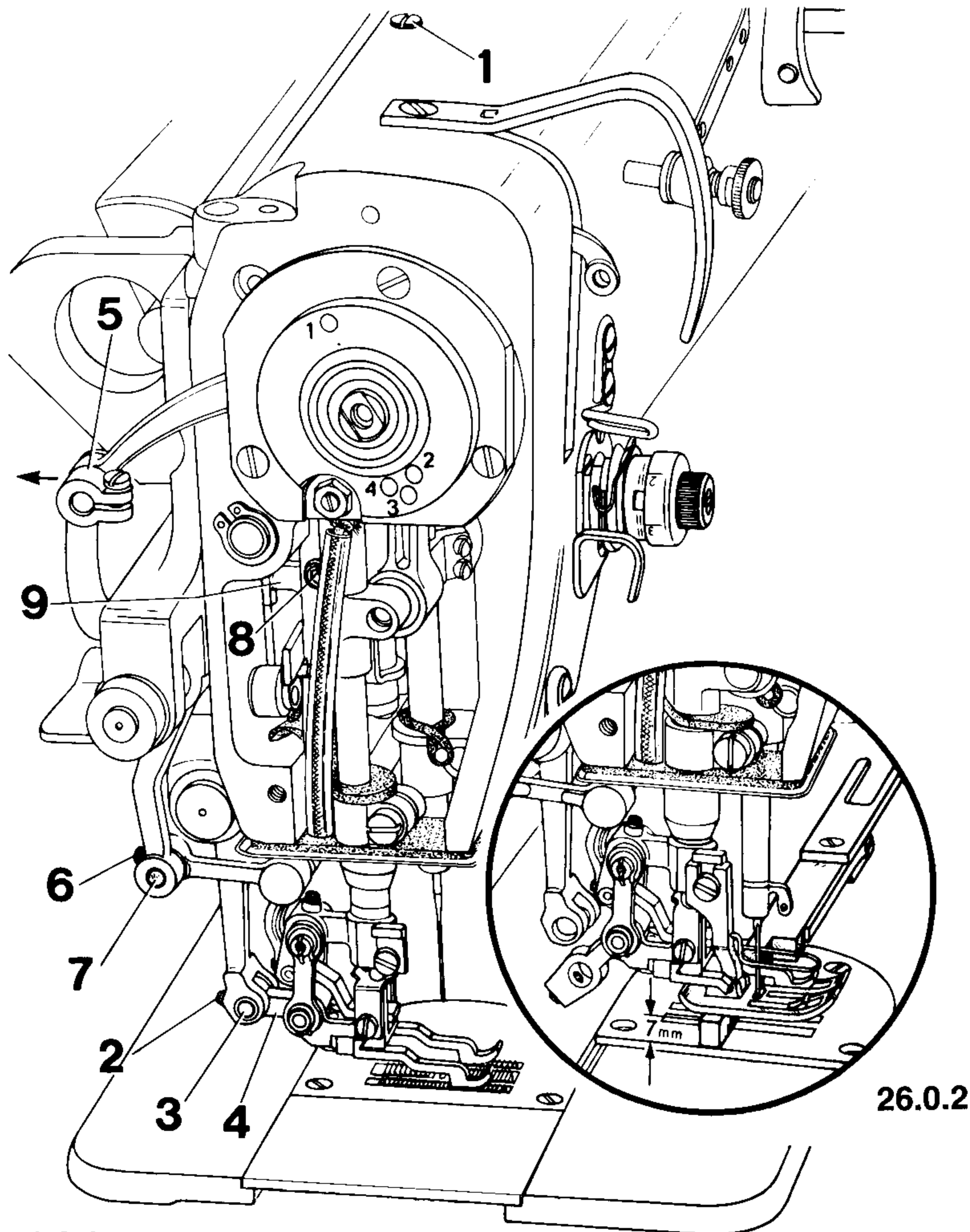

26.0.1

26.0.2

- 26.1 Screw on feed dog, needle plate and bed slide.
- 26.2 Replace the presser foot and lower it onto the needle plate by means of the presser bar lifter.
- 26.3 Reduce the pressure of the presser bar by turning out regulating screw 1 until the presser foot is pressed against the needle plate only slightly.

- 26.4 Loosen screw **2** and push fulcrum stud **3** out.
- 26.5 Swing connecting link **4** out of the yoke of the feed driving lever.
- 26.6 Turn the balance wheel to bring joint **5** to its outward point of reversal (see arrow in Fig. 26.0.1).
- 26.7 Push the 7-mm-thick blade of the gauge under the presser foot so that its recess faces downwards and its front edge is in line with the edge of the needle plate.
- 26.8 Loosen screw **6** and push fulcrum stud **7** out.
- 26.9 Loosen screw **8** of lifting bracket **9**.
- 26.10 Adjust the presser foot laterally until the needle is centred in its needle "hole".
- 26.11 Push the lifting bracket down as far as it will go and tighten screw **9**.
- 26.12 Check this adjustment (see "Correct setting").
- 26.13 Leave the gauge under the presser foot.

Correct setting:

With the stitch length set at "0" and the needle bar at a position **0.25 mm beyond t.d.c.** (pin in hole "3") the feed dog should be centred in its slots and contact the gauge throughout its entire length (Fig. 27.0.2).

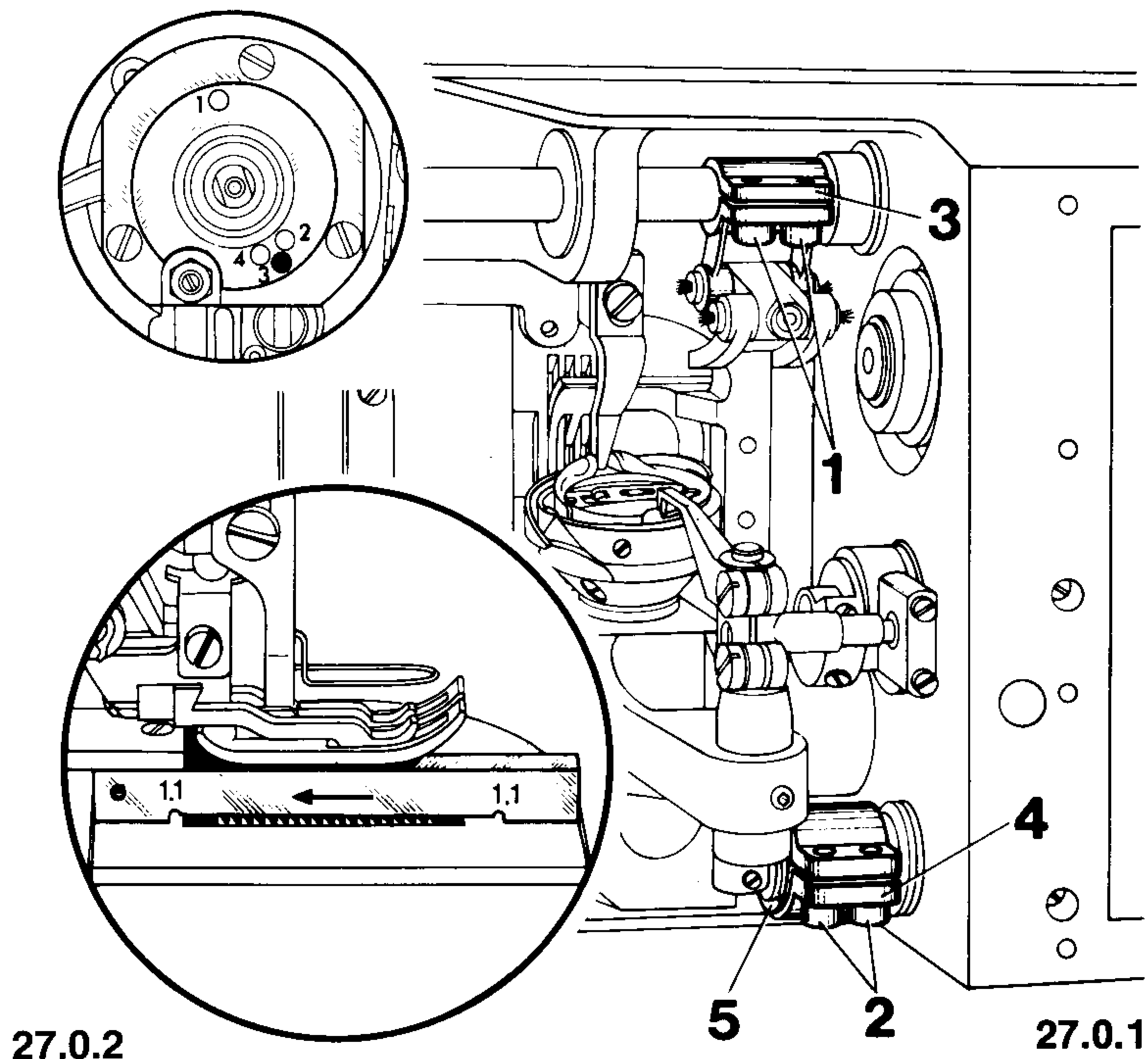

- 27.1 Bring the needle bar to a position **0.25 mm beyond t.d.c.** and insert the pin in hole "3" of the bearing plate (to block the machine).
- 27.2 Loosen clamp screws 1 and 2.
- 27.3 Push the feed bar upwards, centre the feed dog in the needle plate slots and hold it in this position.
- 27.4 Turn feed lifting crank 3 until the feed dog contacts the gauge and tighten clamp screw 1 just lightly.
- 27.5 **Turn eccentric bushing 5 under feed rock shaft crank 4 until the feed dog is in contact with the gauge throughout its entire length and tighten clamp screw 2 lightly too.**
- 27.6 Tighten clamp screws 1 and 2, making sure the feed dog is still in contact with the gauge throughout its entire length.
- 27.7 Raise the presser foot lifter, remove the gauge from under the presser foot and pull the pin out of the hole in the bearing plate.
- 27.8 Check this adjustment (see "Correct setting").

Correct
setting:

All moving parts of the top feed should move freely and have no play.

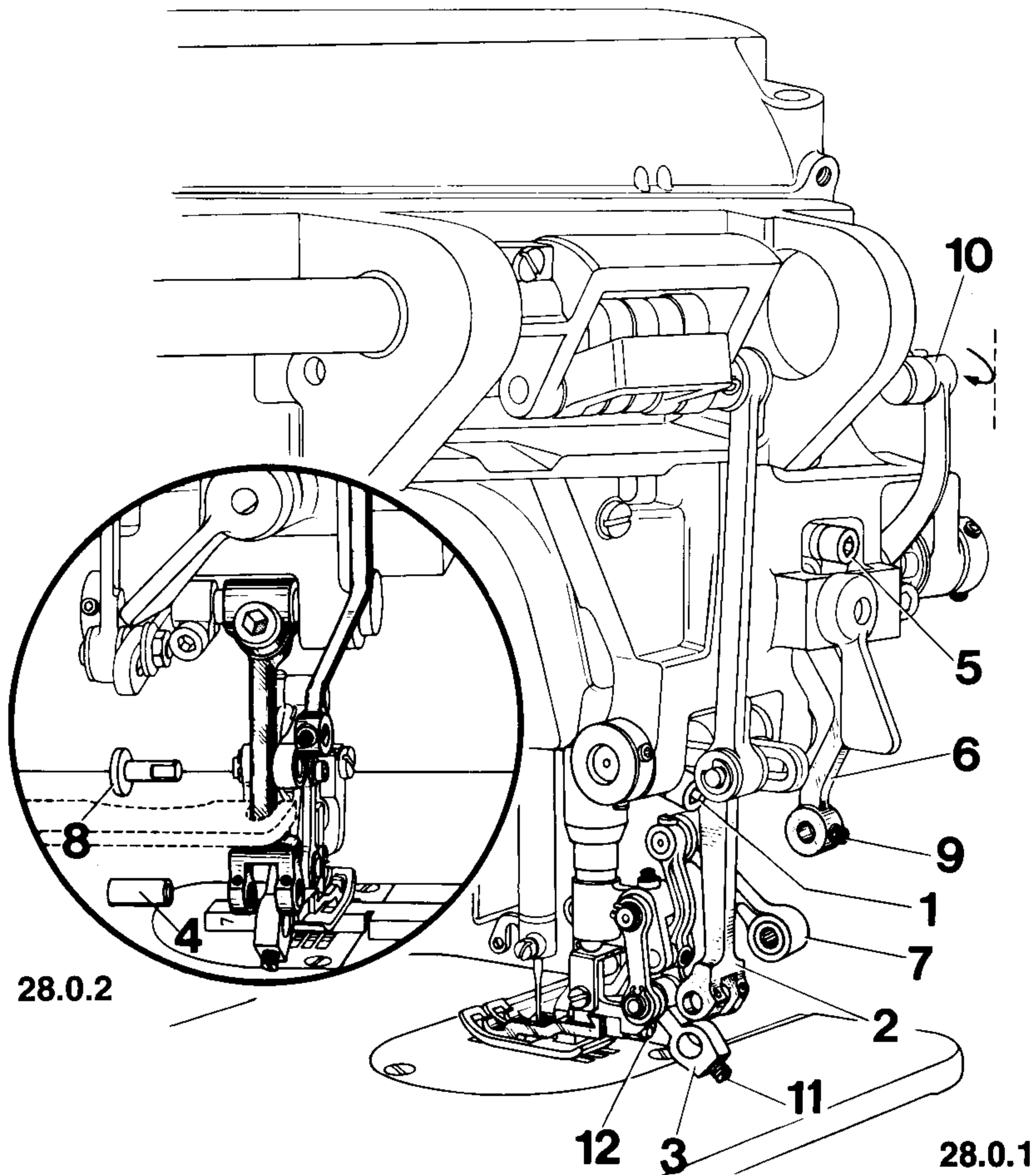

- 28.1 Loosen screw **1**.
- 28.2 Swing connecting link **3** into the yoke of the top feed driving lever **2** so that the holes in both parts are properly aligned.
- 28.3 Insert fulcrum stud **4** in the holes of lever **2** and link **3**, making sure both parts move freely. If necessary, bend lever **2**.
- 28.4 Position the vibrating presser in sewing direction so that it is centred in the slot of the presser foot and, in this position, tighten screw **1**.
- 28.5 Loosen screw **5**.
- 28.6 Bring the hole of connecting lever **6** in line with the hole of connecting link **7**. If necessary, bend connecting lever **6**.
- 28.7 Insert fulcrum stud **8** in both the needle bearing of connecting link **7** and the hole of connecting lever **6** so that screw **9** engages the flat spot of fulcrum stud **8**.

- 28.8 In this position tighten screw **9**.
- 28.9 Turn the balance wheel to bring joint **10** (see arrow in Fig. 28.0.1) to its outward point of reversal.
- 28.10 Push connecting lever **6** toward the rear (in feed direction) until a resistance is felt, and tighten screw **5**.
- 28.11 Remove the gauge and lower the presser foot onto the needle plate.
- 28.12 Tighten screw **11** of fulcrum stud **4**.
- 28.13 Loosen screw **12** of the vibrating presser.
- 28.14 Adjust the vibrating presser laterally so that it is centred in the cutout of the presser foot, then tighten screw **12**.

Correct setting:

With the presser foot resting on the needle plate and the vibrating presser positioned at t.d.c., there should be a clearance of **1.4 mm** between needle plate and vibrating presser if the latter works behind the needle (or of **2.3 mm** if the latter works in front of the needle).

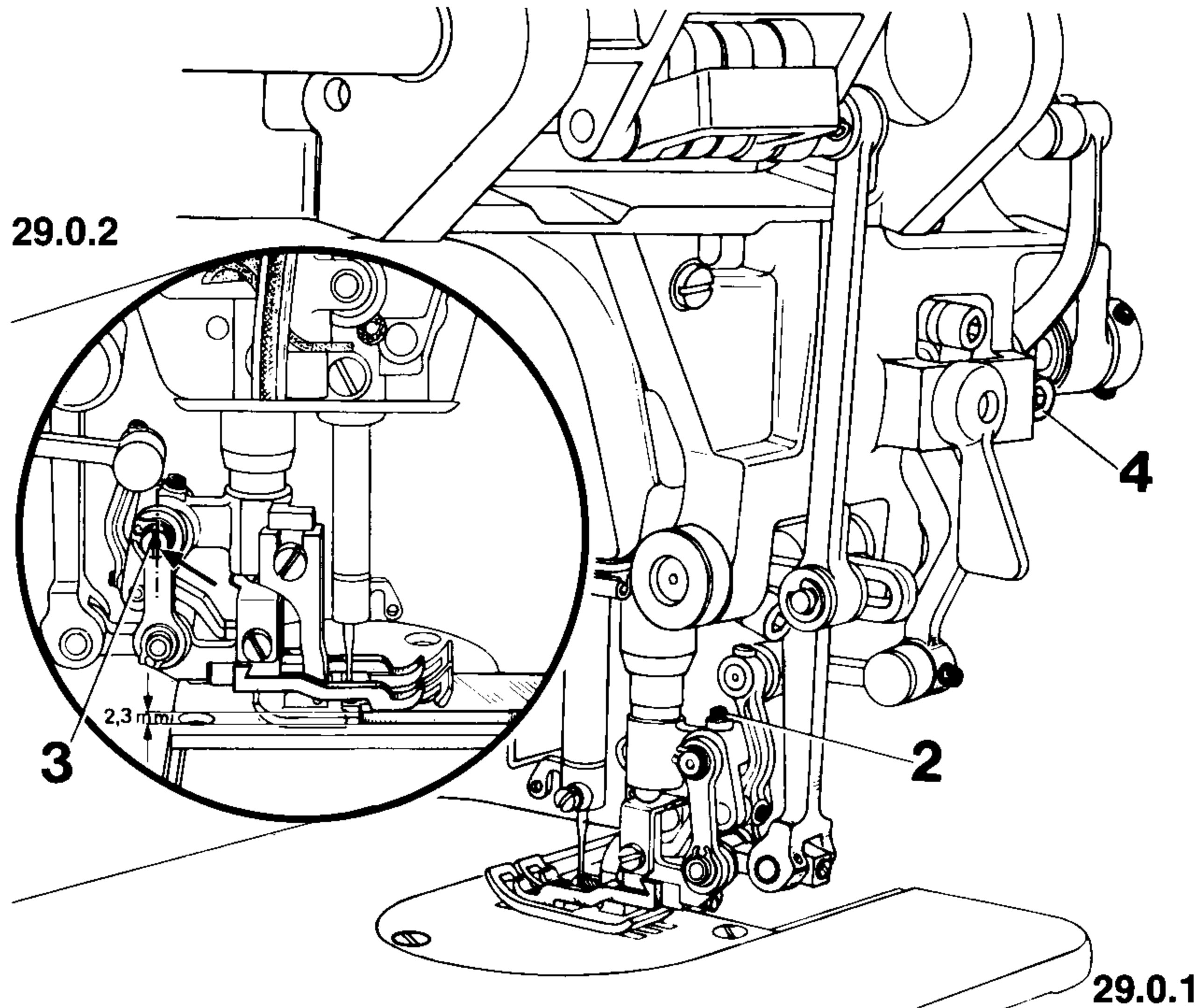

- 29.1 Increase the pressure on the presser bar by turning in regulating screw 1 (Fig. 26.0.1).
- 29.2 Check to make sure the presser foot is still resting on the needle plate.
- 29.3 Loosen screw 2 in the bracket located behind the presser bar.
- 29.4 Turn top feed eccentric stud 3 so that its lobe is up.
- 29.5 In this position tighten screw 2 again.
- 29.6 Turn the balance wheel to bring the vibrating presser to t.d.c.
- 29.7 On machines having a vibrating presser which works behind the needle, push the **1.4-mm-thick** blade of the gauge under the vibrating presser from the rear; on machines where this foot works in front of the needle, push the **2.4-mm-thick** blade of the gauge under the vibrating presser from the front, and hold it fast in this position.
- 29.8 **Slowly loosen screw 4 of the connecting lever so that the vibrating presser rests lightly on the gauge blade.**
- 29.9 In this position securely tighten screw 4 and remove the gauge from under the vibrating presser.
- 29.10 Check this adjustment (see "Correct setting").

Correct
setting:

With the stitch length set at its maximum and the needle bar at a position **1.0 mm beyond t.d.c.** the vibrating presser should make no perceptible motion when the reverse-feed control is moved up and down.

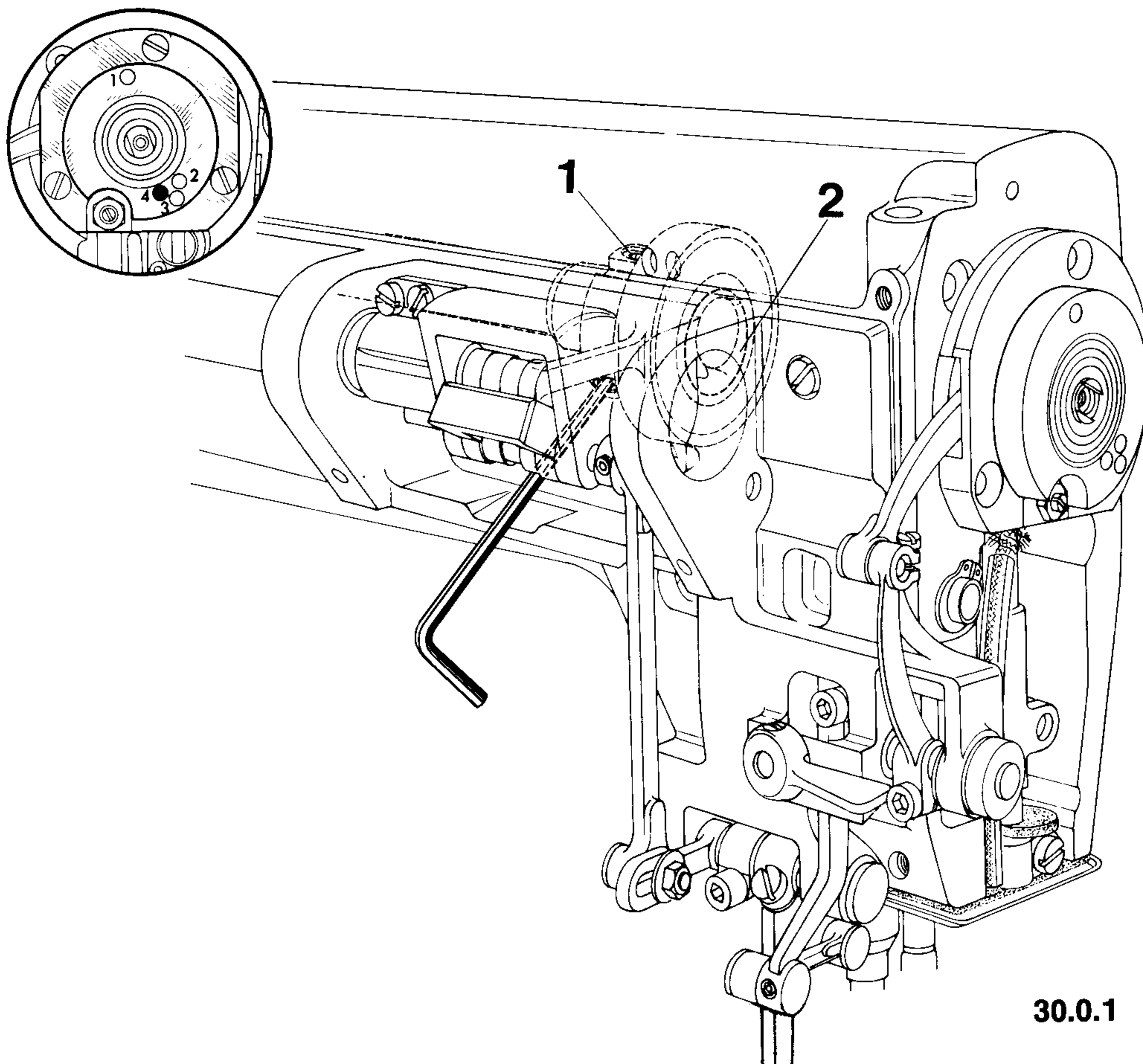

30.0.1

- 30.1 Raise the presser foot and set the stitch length at its maximum.
- 30.2 Loosen screws 1 in feed driving eccentric 2.
- 30.3 Bring the needle bar to a position **1.0 mm beyond t.d.c.** and insert the pin in hole "4" of the bearing plate (to block the machine).
- 30.4 Turn feed driving eccentric 2 until the second screw (as seen in the direction of rotation) is visible at the back.
- 30.5 Continue turning feed driving eccentric 2 slightly while simultaneously moving the reverse-feed control up and down until the vibrating presser remains motionless.
- 30.6 In this position tighten the accessible screw 1.
- 30.7 Pull the pin out of the hole in the bearing plate and tighten the second screw 1.
- 30.8 Check this adjustment (see "Correct setting").

Correct setting:

With the machine set at stitch length "2" the vibrating presser should contact the ascending feed dog when the latter is flush with the surface of the needle plate (Fig. 31.0.2).

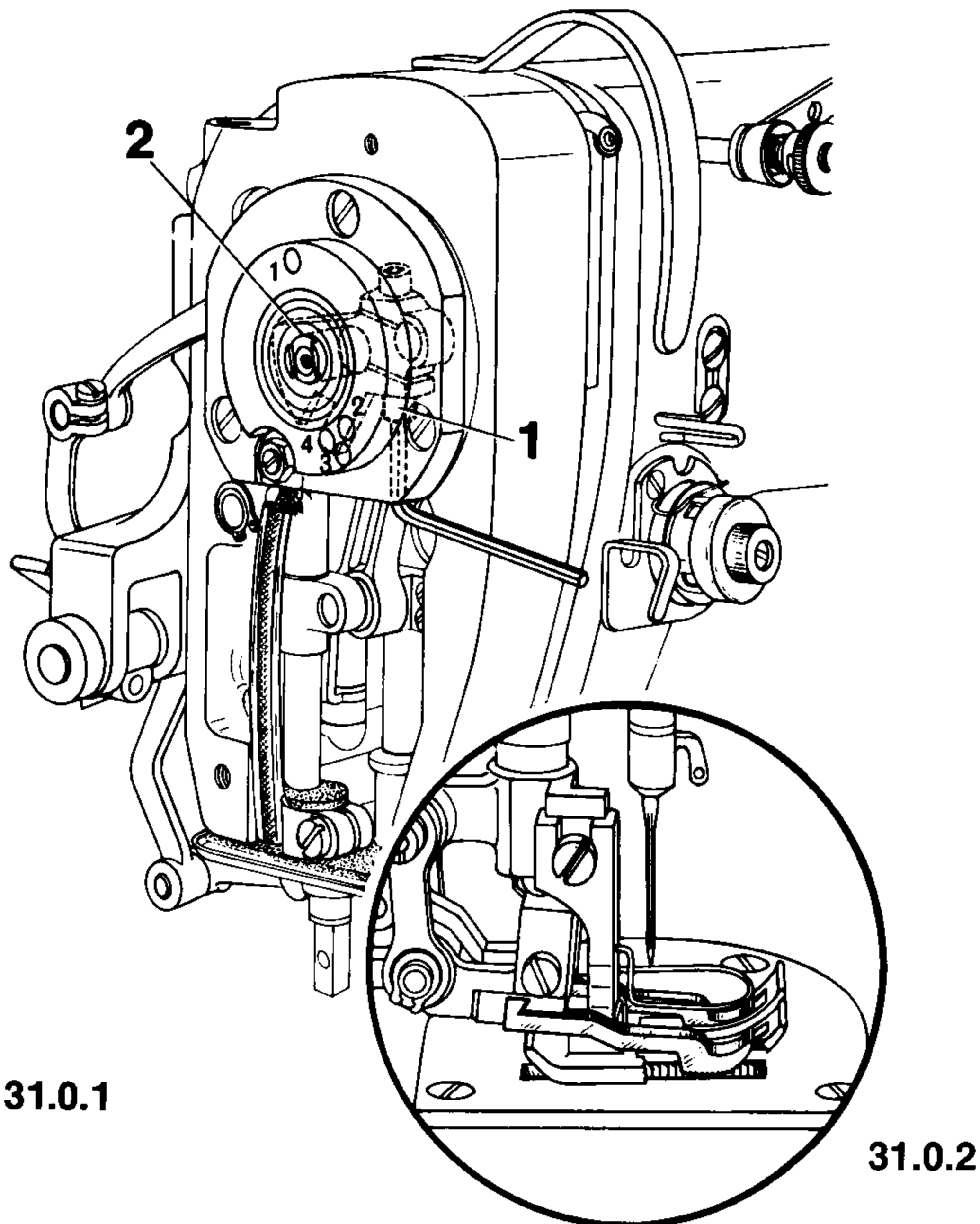

- 31.1 Set the machine at stitch length "2".
- 31.2 Lower the presser foot onto the needle plate.
- 31.3 Bring the take-up lever to its highest position and, in this position, loosen screw 1 which is accessible from below.
- 31.4 Turn the balance wheel until the teeth of the ascending feed dog are flush with the surface of the needle plate.
- 31.5 Hold the balance wheel in this position.
- 31.6 **Turn eccentric stud 2 so that the vibrating presser contacts the feed dog.**
- 31.7 In this position tighten screw 1.
- 31.8 Check this adjustment (see "Correct setting").

Correct setting:

With the scale rings of both milled wheels set at "0" and the machine set for its longest stitch, the feed strokes of the vibrating presser and the feed dog should be the same length when the balance wheel is turned.

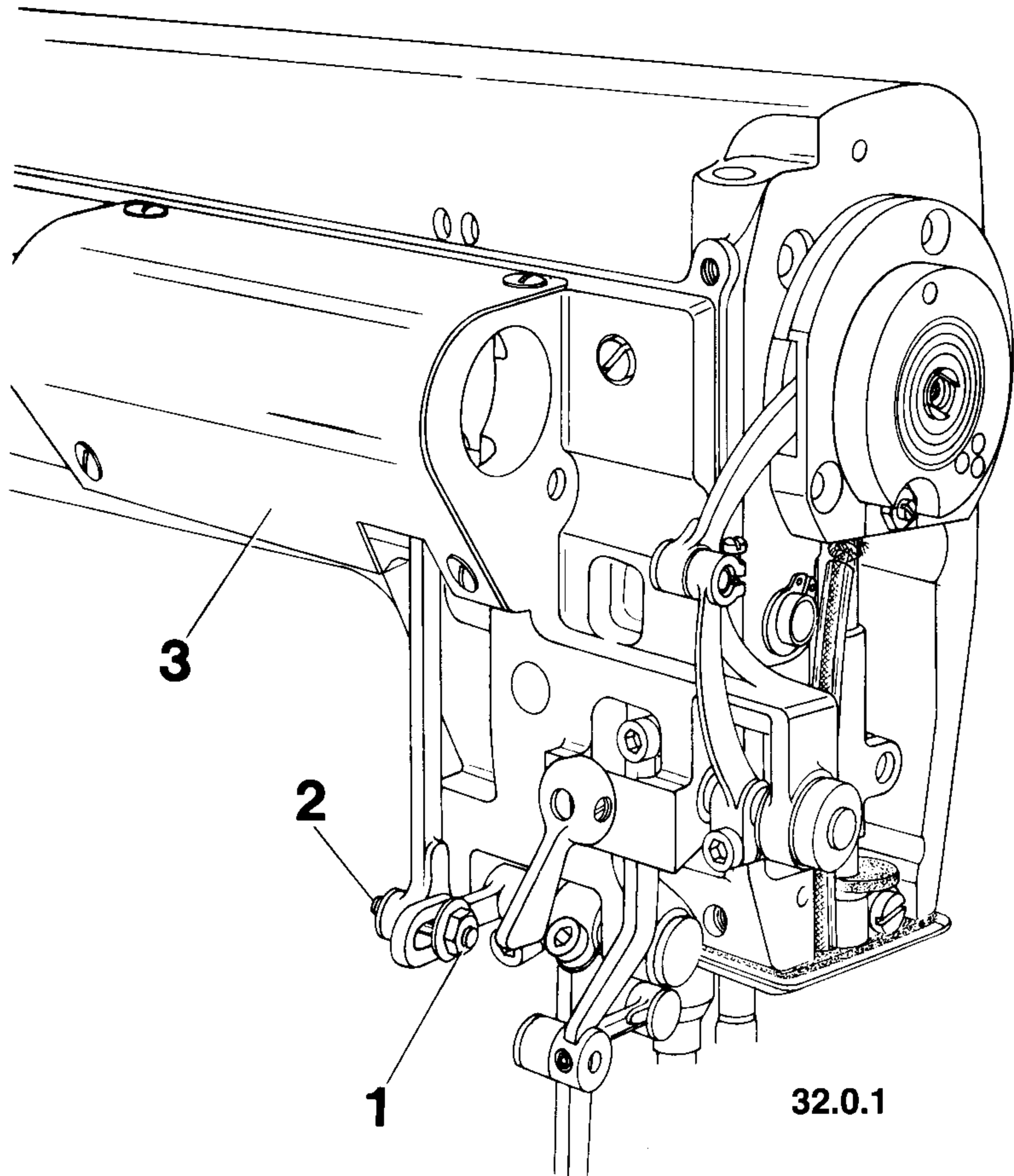

- 32.1 Turn the scale rings of both milled wheels to "0".
- 32.2 Set the machine for its longest stitch.
- 32.3 Loosen nut 1 just sufficiently to allow screw 2 to be turned against resistance.
- 32.4 **Reposition screw 2 in its elongated hole until, when you turn the balance wheel, the feed strokes of the vibrating presser and the feed dog are the same length.**
- 32.5 In this position, tighten nut 1 on screw 2 securely.
- 32.6 Check this adjustment (see "Correct setting").
- 32.7 Replace and screw on cover plate 3 with its four screws.

33 Bobbin winder

33.1 Position of bobbin case opener

Correct setting:

There should be a clearance of **0.8 mm** between bobbin case opener finger and bobbin case base (Fig. 33.0.3). Furthermore, there should be a clearance of **abt. 0.5 mm** between the top of the bobbin case position finger and the inner edge of the bobbin case base (Fig. 33.0.2). And, finally, there should be a clearance of **abt. 0.3 mm** between the right side of the bobbin case slot and the bobbin case position finger when the bobbin case opener is at its left point of reversal (Fig. 33.0.4).

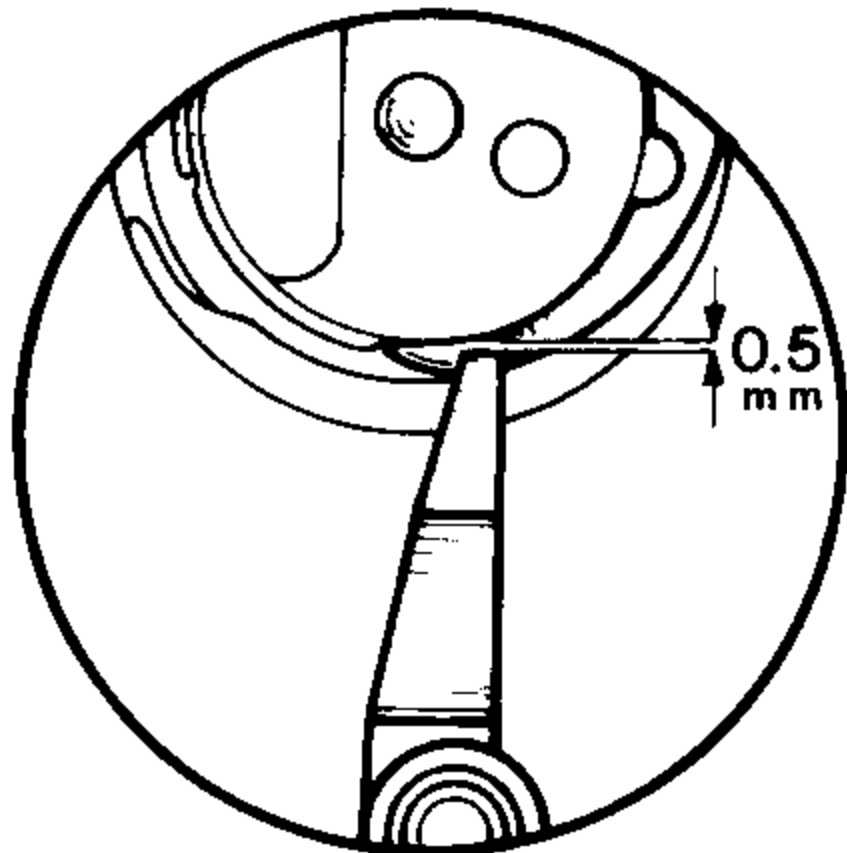

33.0.2

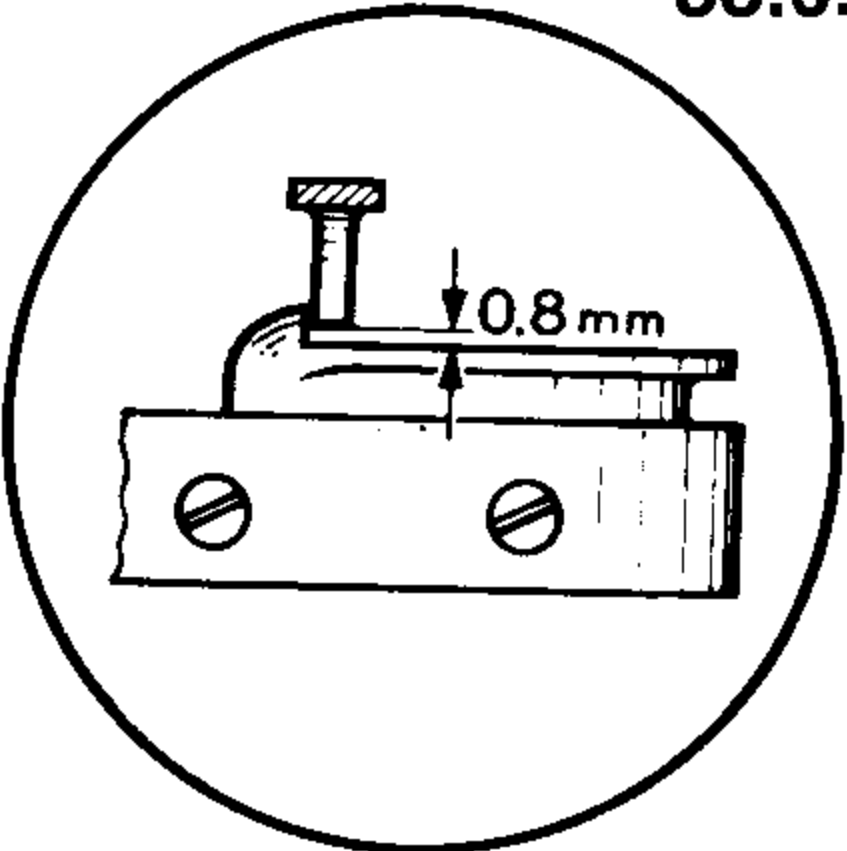

33.0.3

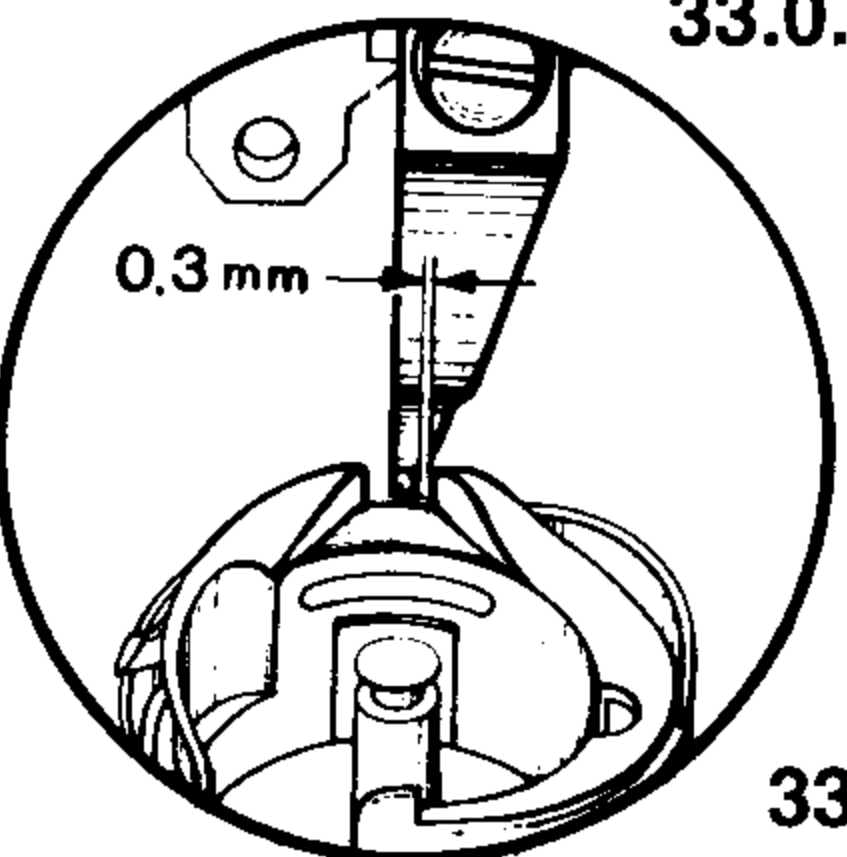

33.0.4

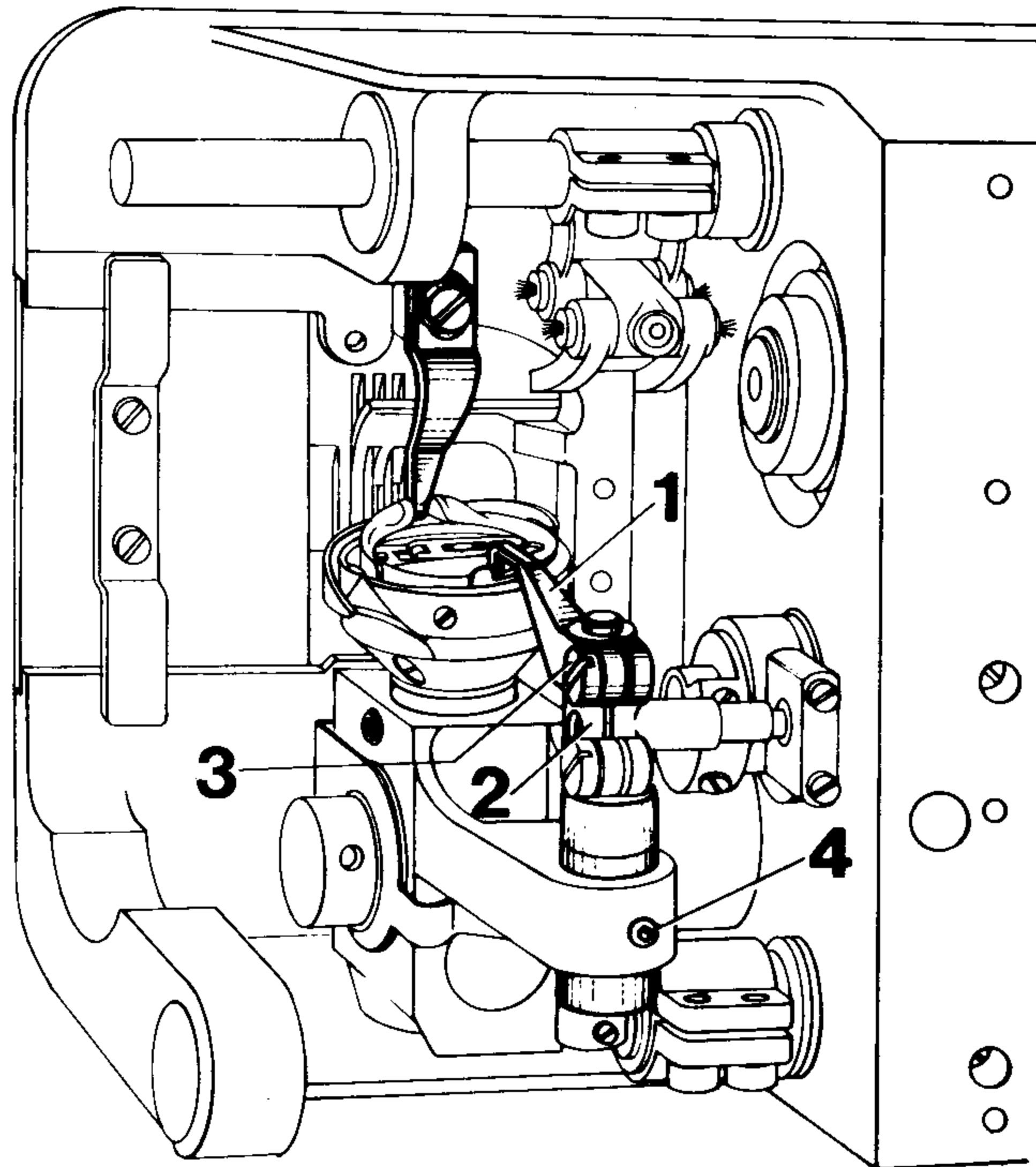

33.0.1

33.1.1 Turn bobbin case opener finger 1 so that it contacts the right side of the bobbin case slot.

33.1.2 Push the opener finger against clamp crank 2 located underneath and tighten clamp screw 3 just sufficiently to allow the opener finger to be turned on its shaft against resistance.

33.1.3 Loosen allen screw 4 of the eccentric bobbin case opener bushing.

- 33.1.4 **Turn the eccentric bushing until there is a clearance of abt. 0.5 mm between the top of the bobbin case opener finger and the inner edge of the bobbin case base (Fig. 33.0.2).**
- 33.1.5 **Adjust the bushing endwise without turning it until there is a clearance of abt. 0.8 mm between bobbin case opener finger and the edge of the bobbin case base (Fig. 33.0.3).**
- 33.1.6 In this position, tighten allen screw 4.
- 33.1.7 Turn the balance wheel to bring the bobbin case opener to its left point of reversal.
- 33.1.8 **Turn the opener finger on its shaft, making sure it still contacts the bobbin case base, until there is a clearance of abt. 0.3 mm between the right side of the bobbin case slot and the bobbin case position finger (Fig. 33.0.4).**
- 33.1.9 In this position tighten clamp screw 3, making sure the bobbin case opener still contacts clamp crank 2 underneath.
- 33.1.10 Check this adjustment (see "Correct setting").

33.2 Timing the bobbin case opener

Correct setting:

When the needle bar is at a position **2.0 mm beyond b.d.c.** (pin in hole "1") the opener finger should be at its right point of reversal (Fig. 33.0.6).

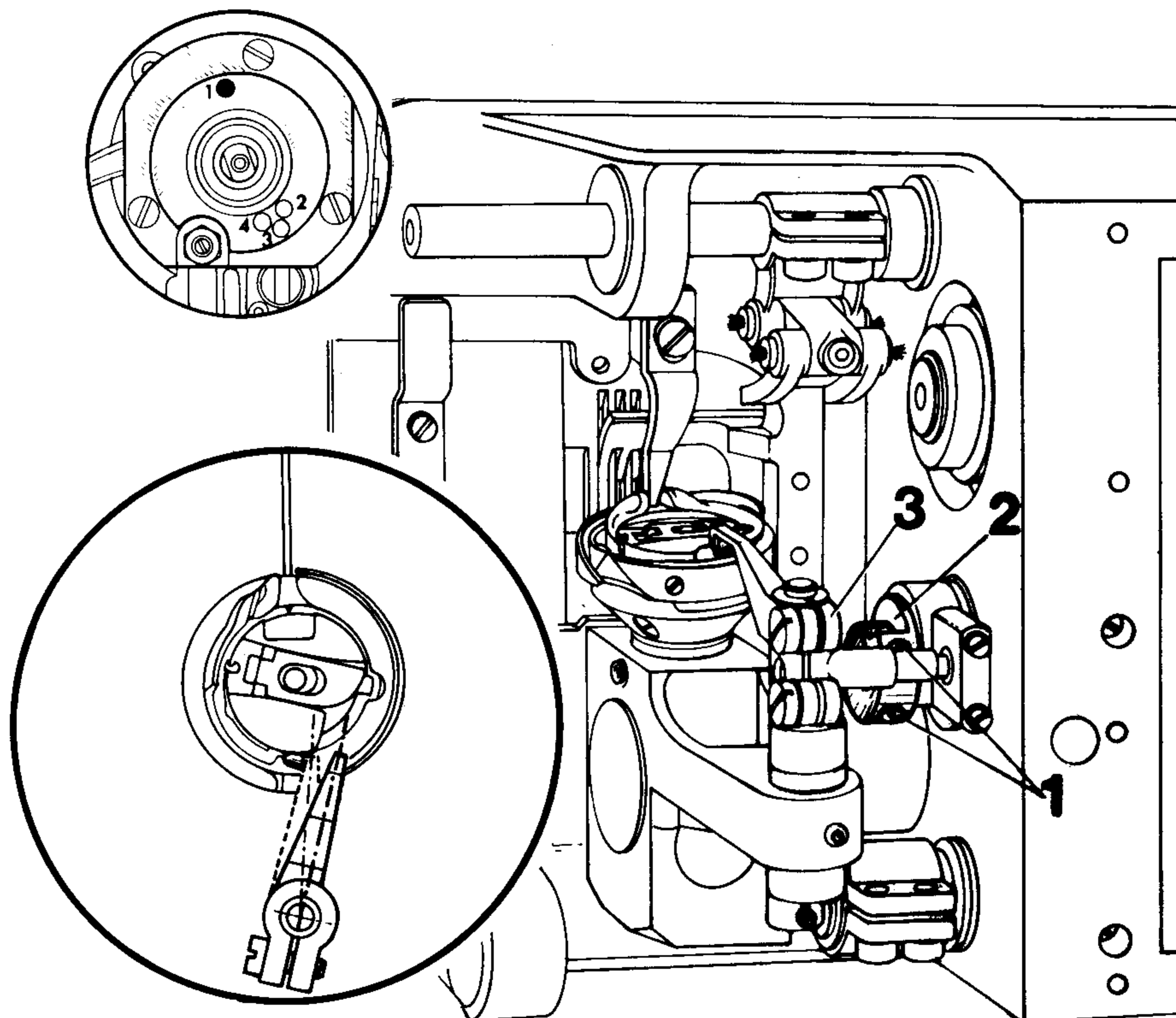

33.0.6

33.0.5

- 33.2.1 Loosen the three screws **1** of bobbin case opener eccentric **2**.
- 33.2.2 Tighten the central screw **1** just sufficiently to allow eccentric **2** to be turned on its shaft against resistance.
- 33.2.3 Bring the needle bar to a position **2.0 mm beyond b.d.c.** and, in this position, insert the pin in hole "1" (to block the machine).
- 33.2.4 To facilitate determining the exact point of reversal insert a small screwdriver in the slot of the clamp of opener finger **3**.
- 33.2.5 **Turn opener eccentric **2** until opener finger **3** is at its right point of reversal (Fig. 33.0.6).**
- 33.2.6 Pull the pin out of the hole in the bearing plate.
- 33.2.7 Tighten the central screw **1** first, then the two outer screws **1**.
- 33.2.8 Pull the screwdriver out of the clamp slot of the bobbin case opener and check this adjustment (see "Correct setting").

Correct setting:

There should be a clearance of **1.0 mm** between actuating rod **2** of the centrifugal governor and push rod **3** of the oil check valve (Fig. 34.0.2).

Note:

If the machine has been in operation for a longer time, it is recommended to fill the gearcase with abt. 130 c.c. of Pfaff sewing machine oil No. 280-1-120 144 having a viscosity of $16.0 \text{ mm}^2/\text{s}$ at 50°C and a density of $0.88 \text{ kg}/\text{dm}^3$ before the gearcase cover is closed. The two oil pads, which are available under Nos. 91-168 383-05 and 91-168 384-05, should be replaced too.

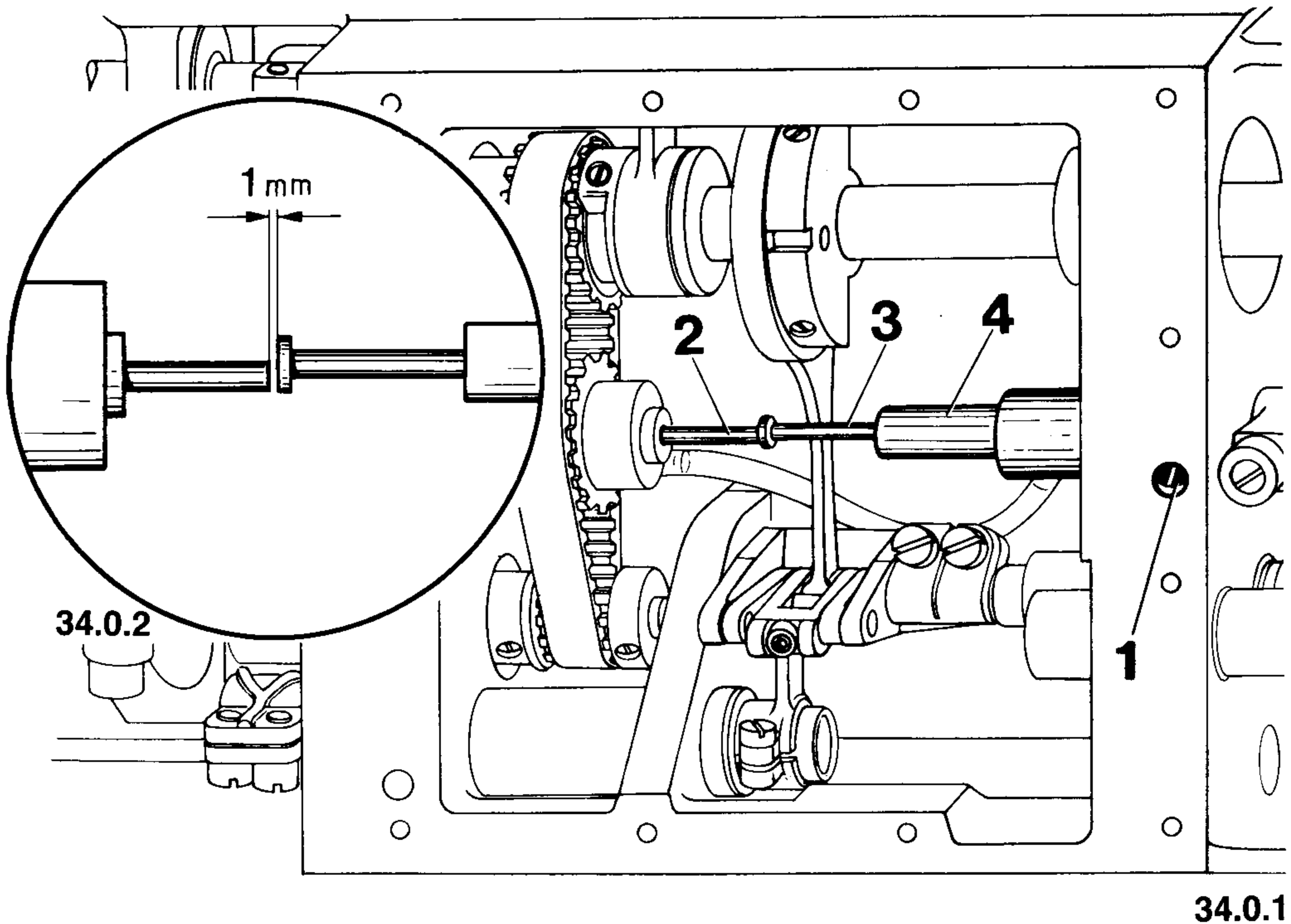

34.0.1

- 34.1 Loosen screw **1** of the oil check valve.
- 34.2 Push actuating rod **2** to the left as far as it will go.
- 34.3 Press push rod **3** into oil check valve **4** until a resistance is felt.
- 34.4 **Reposition oil check valve 4 until there is a clearance of 1.0 mm between actuating rod 2 and push rod 3 (Fig. 34.0.2).**
- 34.5 In this position tighten screw **1**.
- 34.6 Place the oil pad in the gearcase so that the vertical fin in the gearcase is position in its smallest cutout.
- 34.7 Clean the gasket face on the gearcase and the gasket of the gearcase cover.
- 34.8 Replace the gearcase cover and tighten its screws crosswise.
- 34.9 Check this adjustment (see "Correct setting").

Tension release mechanism

(This adjustment procedure does **not** apply to machines equipped with subcl. -900 thread trimmer.)

Correct setting:

When the presser bar lifter is raised both tension discs should be at least **0.5 mm** apart (Fig. 35.0.2).

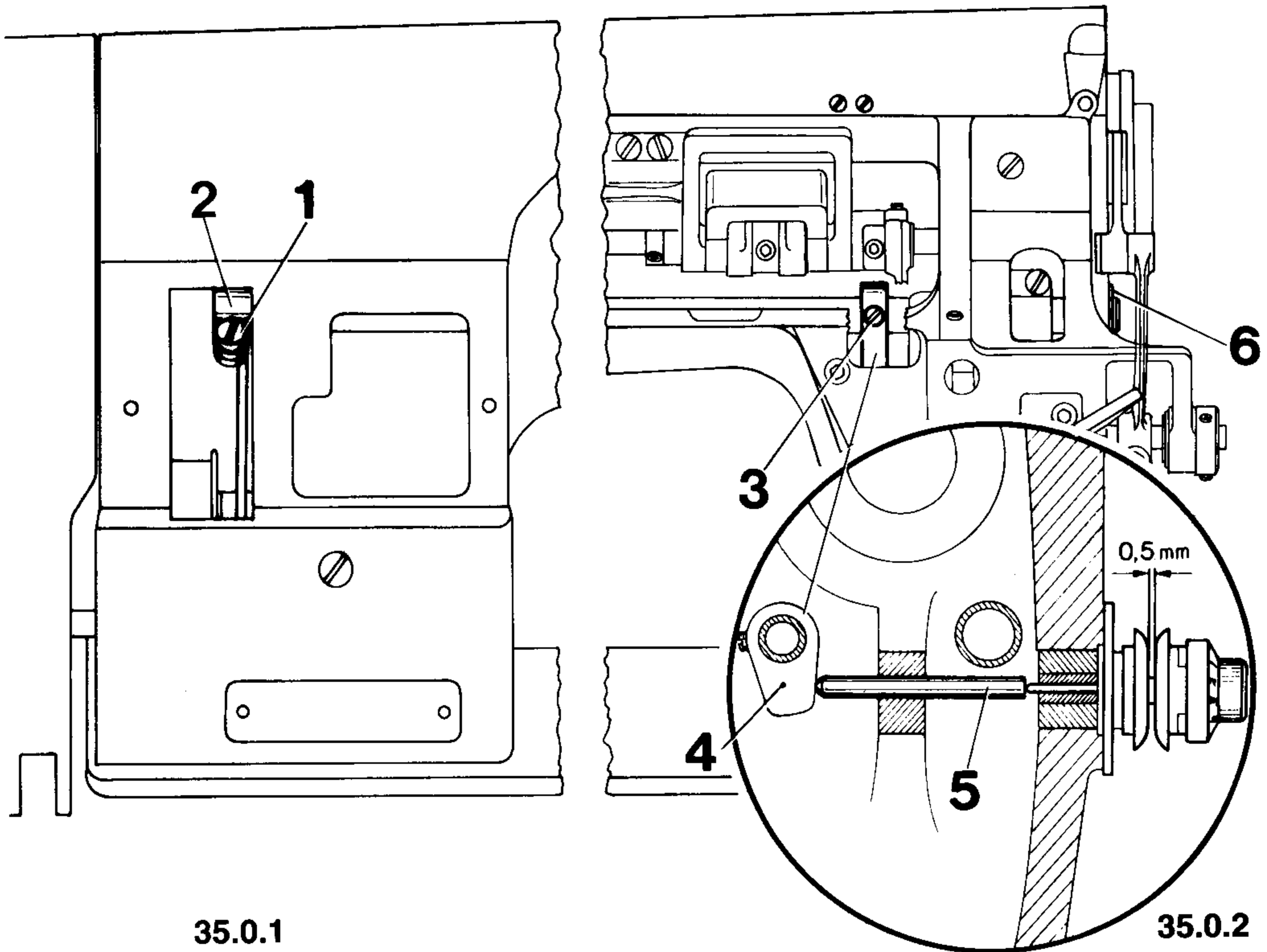

35.0.1

35.0.2

- 35.1 Lower the presser foot onto the needle plate.
- 35.2 Loosen clamp screw 1 of lifting lever crank 2.
- 35.3 Bring the needle bar to **b.d.c.**
- 35.4 Raise the presser foot and place the feed dog gauge under the foot with its recess up.
- 35.5 Lower the presser foot into the recess of the gauge.
- 35.6 Loosen screw 3 of tension release cam 4.

- 35.8 **Adjust tension release cam 4 on its shaft so that it is positioned exactly opposite tension release pin 5.**
- 35.9 Swing up the presser bar lifter until a resistance is felt.
- 35.10 **In this position, push tension release cam 4 up against tension release pin 5 and tighten screw 3.**
- 35.11 Remove the feed dog gauge from under the presser foot and lower the presser foot onto the needle plate again.
- 35.12 Push the connecting rod of crank 2 downwards as far as it will go.
- 35.13 Tighten clamp screw 1, making sure that retaining ring 6 on the lifting shaft is still in contact with the face side of the machine and crank 2 contacts the casting.
- 35.14 Check this adjustment (see "Correct setting").
- 35.15 Screw on the face cover.

36 Lubrication of zigzag eccentric

36.1 Fill the zigzag eccentric housing with abt. 100 c.c. of oil.

Note:

Only use Pfaff sewing machine oil having a viscosity of 16.0 mm ² /s at 50°C and a density of 0.88 kg /dm ³ (No. 280-1-120 144).
--

When the oil is replenished later the excess oil flows through an overflow duct from the hook oil reservoir to the zigzag eccentric housing, thus filling the latter. Keep topping up oil until the oil level is in line with the upper mark in the small circle of the oil reservoir.

36.2 Clean the gasket face on the cover of the zigzag eccentric housing and the gasket of this cover.

36.3 Screw on the cover, making sure that the needle bar lubricating wick is still positioned in the hole of the sealer plate.

Correct setting:

After the machine has run at full speed for about ten seconds, a fine trace of oil should appear on a piece of paper placed over the needle plate cutout above the hook raceway.

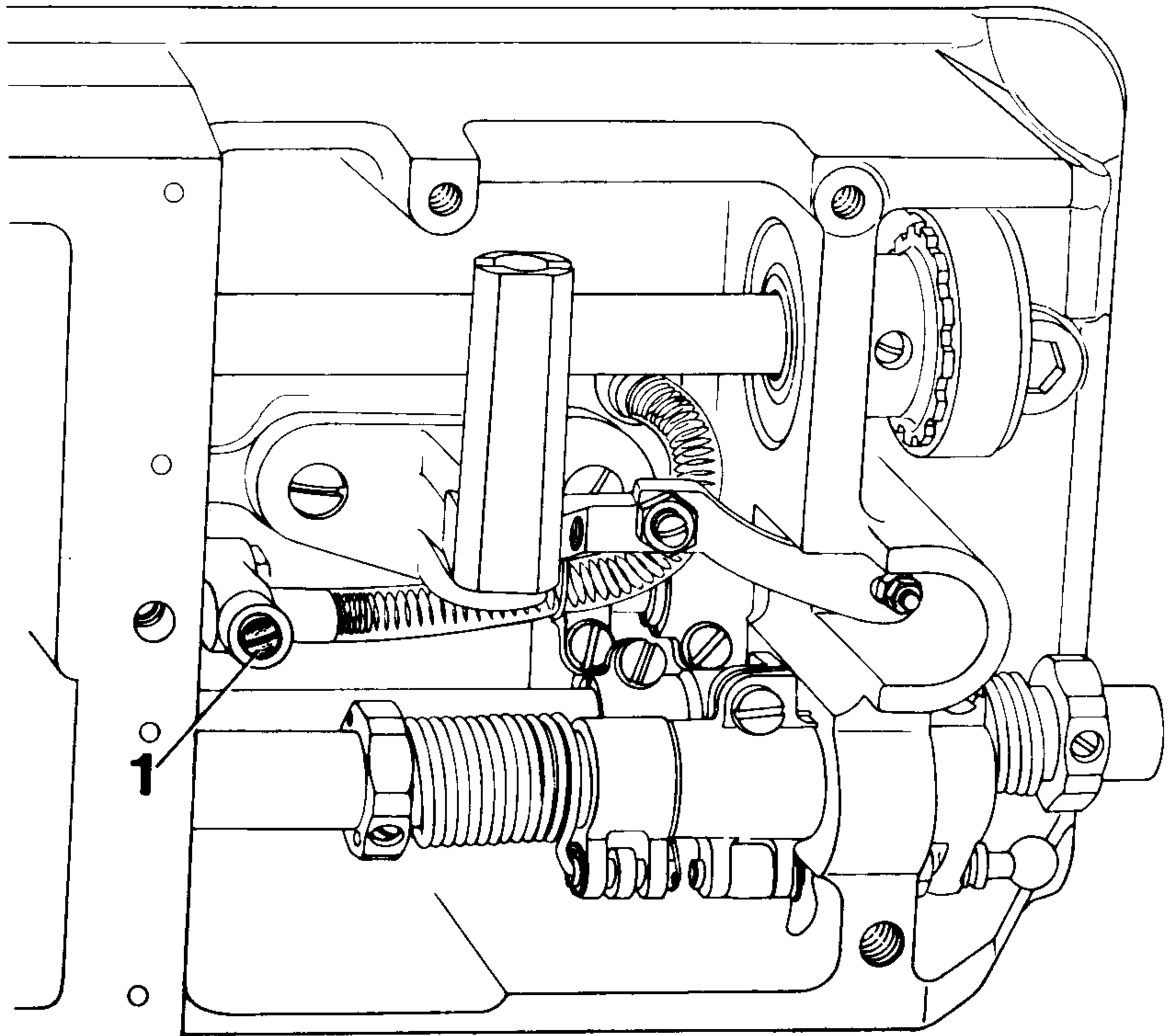

37.0.1

- 37.1 Check the oil level and, if necessary, top up the reservoir with oil (No. 280-1-120 144) until the oil level is in line with the upper mark.
- 37.2 Turn in regulating screw **1** of the oil check valve as far as it will go, and then back about half a turn.
- 37.3 Switch on the machine and run it for about one minute.
- 37.4 Remove needle plate and feed dog and take the needle out of the needle bar.
- 37.5 Place a piece of white paper over the needle plate cutout and hold it there.
- 37.6 Let the machine run about ten seconds. Then check to see if a fine trace of oil has appeared on the paper opposite the hook raceway.
- 37.7 **If too much oil is emitted, turn regulating screw 1 in a little; or if too little oil is emitted turn it out somewhat.**
- 37.8 Check this adjustment (see "Correct setting").
- 37.9 Replace and screw on feed dog and needle plate.
- 37.10 Replace the needle in the needle bar.

Correct setting:

When the knee lever is fully operated, the presser foot should be lifted from the needle plate by a little more than 7.0 mm and the presser bar lifter should drop by its own weight.

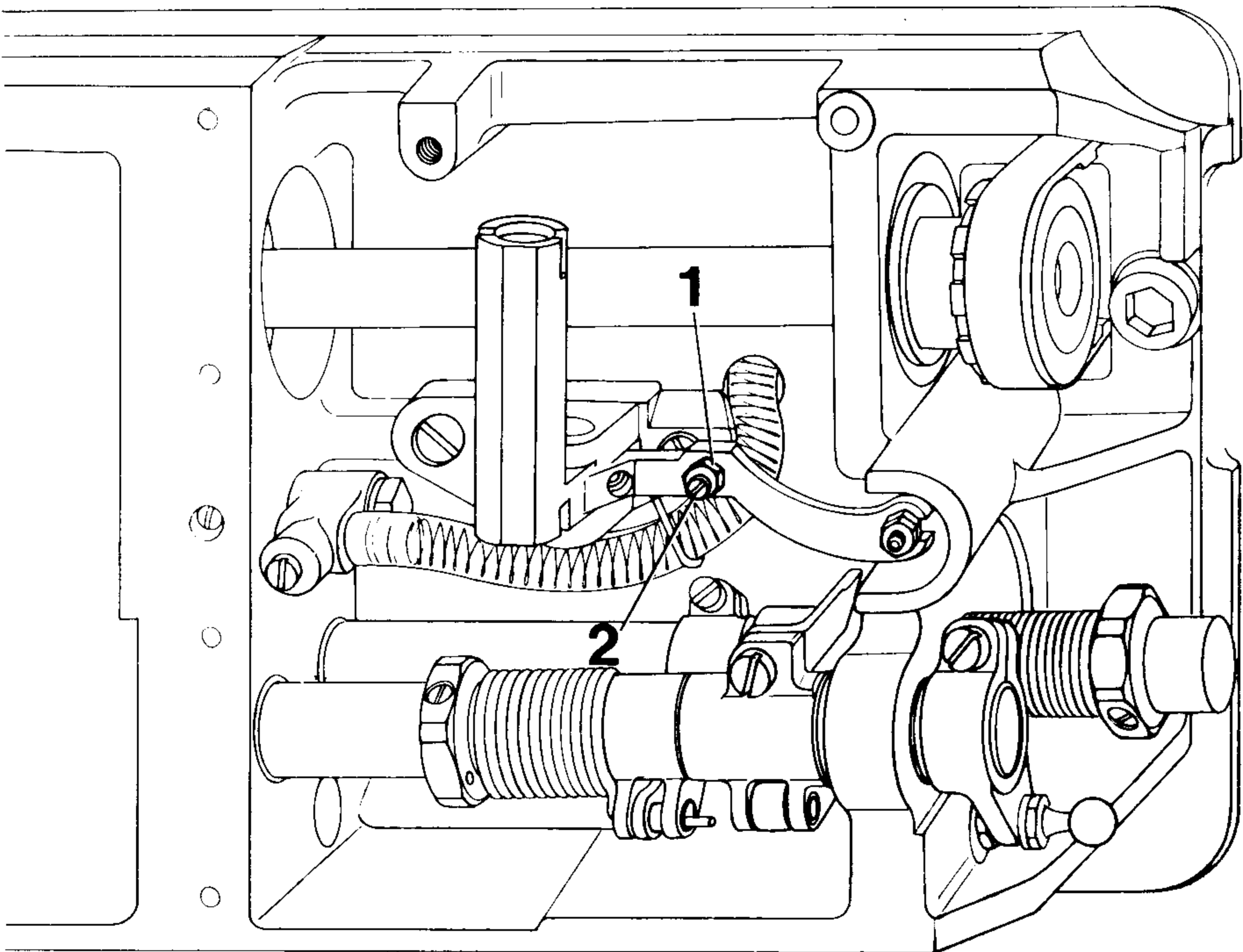

38.0.1

- 38.1 Place the feed dog gauge under the presser foot so that its recess faces the needle plate.
- 38.2 Lower the presser foot onto the feed dog gauge.
- 38.3 Loosen locknut 1 and turn stop screw 2 out a few turns.
- 38.4 **Move the knee lever to the right until a noticeable resistance is felt; however the presser foot must not be lifted off the gauge.**
- 38.5 **Hold the knee lever at this position and turn stop screw 2 in as far as it will go, then back out by one turn, and lock it in place with locknut 1.**
- 38.6 Remove the feed dog gauge from under the presser foot.
- 38.7 Check this adjustment (see "Correct setting").

Correct
setting:

There should be a noticeable amount of play between nut **2** and forked connection **3** when the knee lever is operated just lightly.

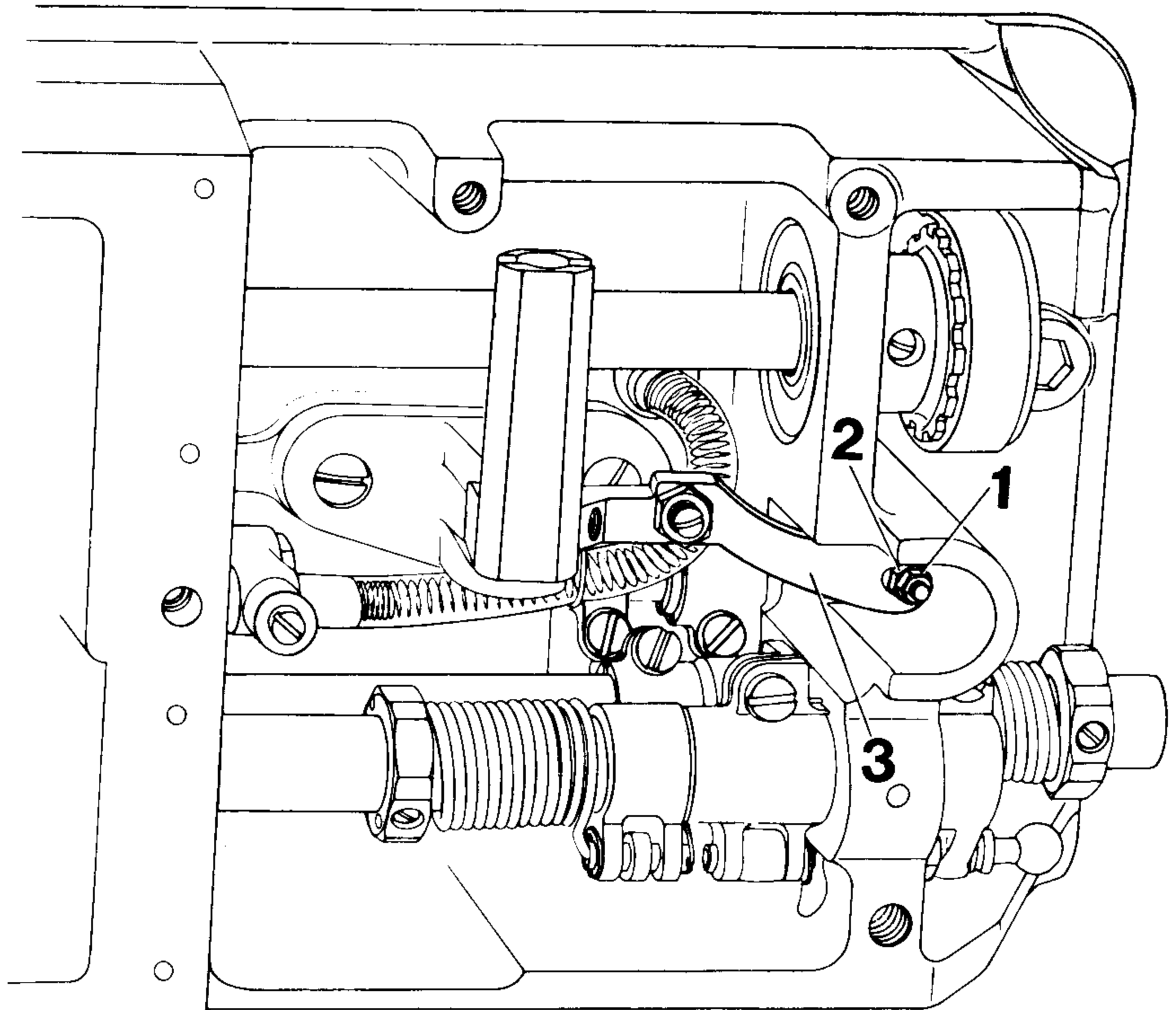

39.0.1

- 39.1 Loosen locknut **1** of nut **2**.
- 39.2 **Turn in nut 2 until there is a noticeable amount of play between it and forked connection 3 when the knee lever is operated just lightly.**
- 39.9 Lock nut **2** in place by tightening locknut **1**.
- 39.4 Check this adjustment (see "Correct setting").

Correct setting:

When the bobbin winder is engaged, the winder spindle should be driven reliably; when the bobbin winder is disengaged, however, friction wheel 3 must not contact drive wheel 2. The bobbin winder should stop automatically when the thread wound on the bobbin has reached a point abt. **1 mm** below its rim (Fig. 40.0.2).

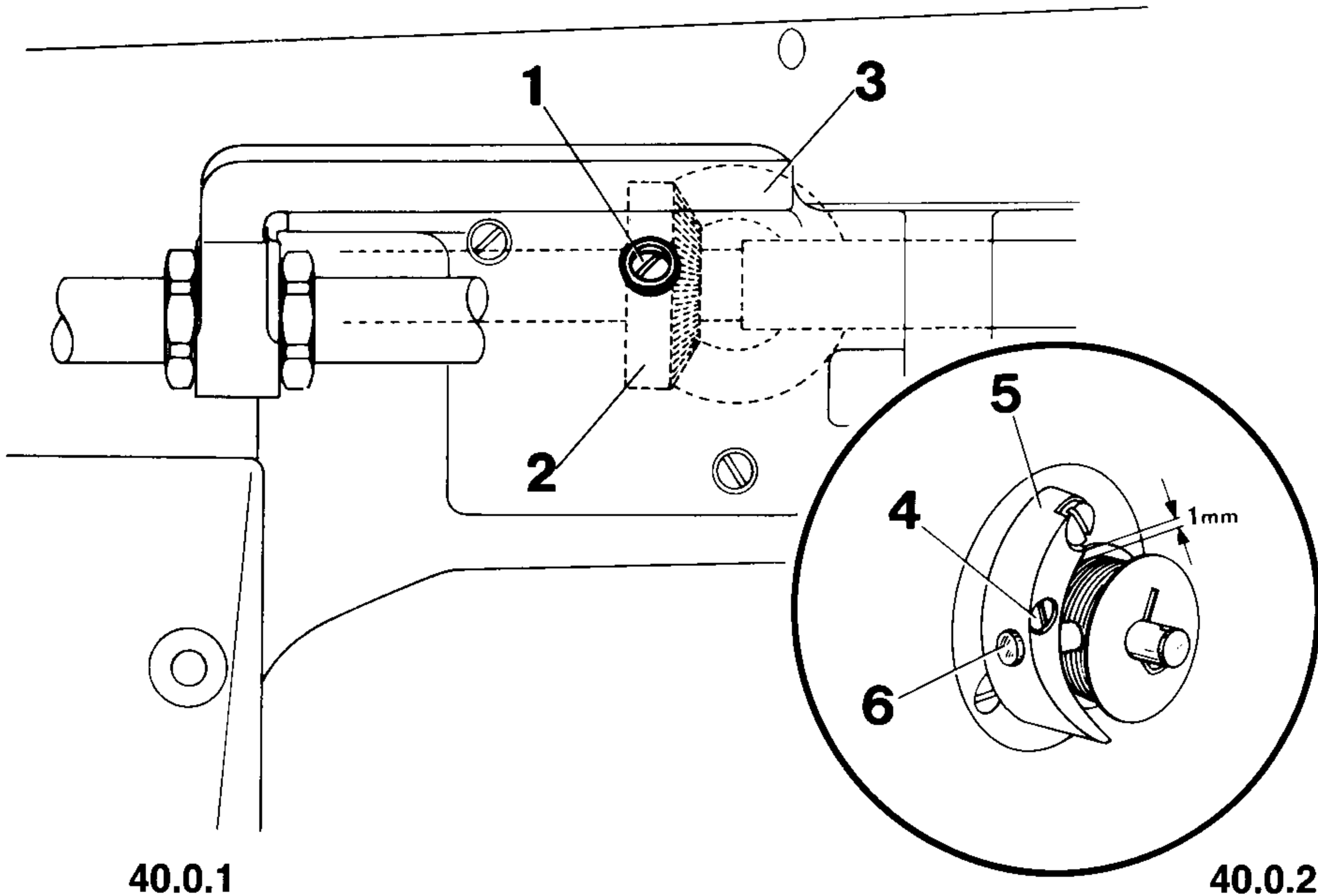

- 40.1 Raise the presser bar lifter and engage the bobbin winder.
- 40.2 Loosen both screws 1 in drive wheel 2.
- 40.3 **Set drive wheel 2 so close to friction wheel 3 that the bobbin winder spindle will be driven reliably when the bobbin winder is engaged, but that friction wheel 3 will not be driven, by drive wheel 2 when the bobbin winder is disengaged.**
- 40.4 Tighten both screws 1.
- 40.5 Place a bobbin on the winder spindle, thread the machine for bobbin winding, engage the bobbin winder and start the machine.
- 40.6 Loosen screw 4 of stop latch 5.
- 40.7 **If the bobbin is too full, push regulating stud 6 toward the right, if the bobbin is not full enough, push it toward the left.**
- 40.8 After the adjustment, tighten screw 4.
- Note: If the thread piles up on one side of the bobbin, adjust the thread guide on the machine arm accordingly.
- 40.9 Check this adjustment (see "Correct setting").

41 Thread check spring and thread regulator

Correct setting:

The stroke of the thread check spring should be completed when the point of the needle reaches the material (abt. 7.0 mm stroke).

Note:

Special sewing operations may make it necessary to choose a longer or shorter stroke.

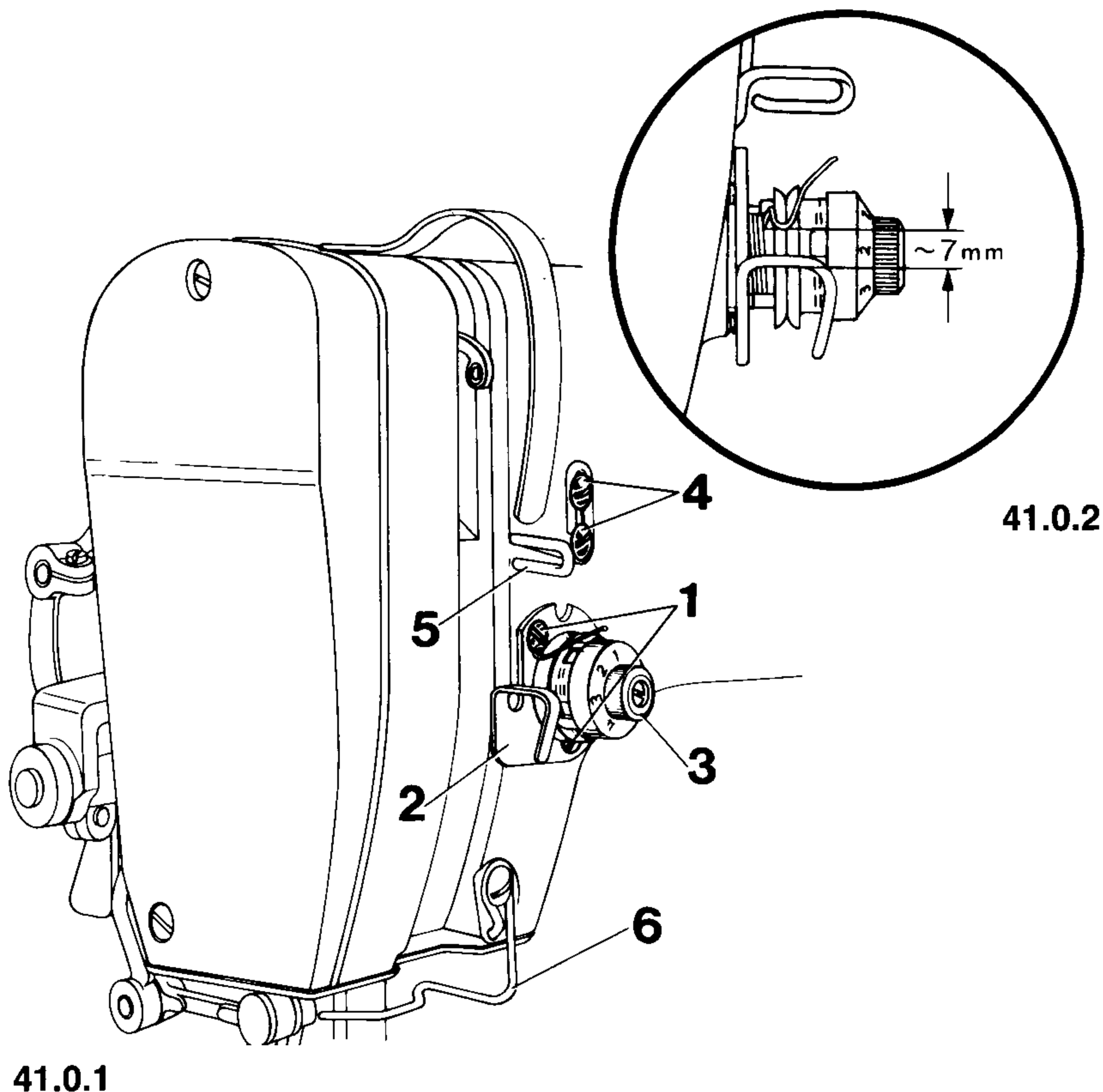

- 41.1 Loosen both screws 1 of thread tension plate 2 just sufficiently to allow the tension barrel to be turned in this plate.
- 41.2 **Turn tension barrel 3 until the stroke of the thread check spring amounts to abt. 7.0 mm.**
- 41.3 In this position, tighten both screws 1 of thread tension plate 2 evenly.
- 41.4 Check this adjustment (see "Correct setting").
- 41.5 Loosen both screws 4 of thread regulator 5.
- 41.6 **Push the thread regulator up as far as it will go.**
- 41.7 In this position, tighten both screws 4. (The position of the thread regulator is dependent on the type of thread and material used and should be adjusted according to the appearance of the seam).
- 41.8 Screw on thread guide 6.

42 Presser foot pressure

- 42.1 Thread the machine, place a piece of fabric under the presser foot and lower the presser foot onto it.
- 42.2 Turn in regulating screw 1 (Fig. 26.0.1) until proper feeding of the material is ensured even at top speed.

Contents

	Page
1 Preparations for adjusting	2
2 Centring the needle in the needle hole (in sewing direction)	4
3 Setting the stabilizing rod parallel to the needle bar	5
4 Stitch width control	7
5 Adjusting the needle in the needle hole (sideways)	11
6 Adjusting the needle throw	12
7 Needle position "left, centre, right"	13
8 Adjusting the needle position lever	15
9 Adjusting the stitch length scale ring	16
10 Zeroing the differential feed	17
11 Stitch length indicator	18
12 Zeroing the bottom feed	19
13 Top feed connecting rod	21
14 Zeroing the top feed motion	22
15 Adjusting the torsion springs	23
16 Adjusting the bottom feed driving motion	25
17 Bottom feed lifting motion	26
18 Tensioning the driving belt in the gearcase	27
19 Adjusting the hook bearing bracket	28
20 Preliminary adjustment of needle bar height	29
21 Oil distributor ring	30
22 Inserting the oil tube in the oil distributor ring	31
23 Hook timing and hook-to-needle clearance	32
24 Final adjustment of needle bar height	33
25 Adjusting the slack thread control	34
26 Clearance between presser foot and needle plate	35
27 Feed dog height	37
28 Top feed driving and connecting levers	38
29 Vibrating presser height	40
30 Vibrating presser advancing motion	41
31 Vibrating presser lifting motion	42
32 Eliminating differences in the feed stroke lengths	43
33 Bobbin winder	44
34 Oil check valve	47
35 Tension release mechanism	48
36 Lubrication of zigzag eccentric	50
37 Hook lubrication	51
38 Knee lever stroke limitation	52
39 Knee lever play	53
40 Bobbin winder	54
41 Thread check spring and thread regulator	55
42 Presser foot pressure	56

