

PFAFF

337

Instruction manual

This instruction manual applies to machines from the following serial numbers onwards:

546 762 →



This Instruction manual is valid for all models and subclasses listed in the chapter „**Specifications**“:

The reprinting, copying or translation of PFAFF Instruction Manuals, whether in whole or in part, is only permitted with our previous permission and with written reference to the source.

**G.M. PFAFF KAISERSLAUTERN
INDUSTRIEMASCHINEN AG**

Postfach 3020
D - 67653 Kaiserslautern

Königstr. 154
D - 67655 Kaiserslautern

Editing/Illustrations

Verlag - TD

D - 77901 Lahr

	Chapter - Page
Contents	Chapter - Page
1 Safety	1 - 1
1.01 Directives	1 - 1
1.02 General notes on safety	1 - 1
1.03 Safety symbols	1 - 2
1.04 Important notes for the user	1 - 2
1.05 Operating and technical staff	1 - 3
1.05.01 Operating staff	1 - 3
1.05.02 Technical staff	1 - 3
1.06 Danger warnings	1 - 4
2 Proper use	2 - 1
3 Specifications	3 - 1
3.01 PFAFF 337	3 - 1
3.02 Models and subclasses	3 - 1
4 Machine disposal	4 - 1
5 Transportation, packing and storage	5 - 1
5.01 Transportation to customer's premises	5 - 1
5.02 Transportation inside customer's premises	5 - 1
5.03 Disposal of packing materials	5 - 1
5.04 Storage	5 - 1
6 Explanation of symbols	6 - 1
7 Controls	7 - 1
7.01 On/off switch	7 - 1
7.02 Pedals	7 - 1
7.03 Presser bar lifter	7 - 2
7.04 Feed regulator lever	7 - 2
7.05 Top feed stroke limitation	7 - 3
7.06 Visual indicator -921/01 (optional)	7 - 3
7.07 Top feed stroke adjustment	7 - 4
8 Installation and commissioning	8 - 1
8.01 Installation	8 - 1
8.01.01 Adjusting the table height	8 - 1
8.01.02 Tensioning the v-belt	8 - 2
8.01.03 Fitting the upper belt guard	8 - 2
8.01.04 Fitting the lower belt guard	8 - 3
8.01.05 Assembling the reel stand	8 - 3
8.01.06 Fitting the sewing lamp	8 - 3
8.02 Commissioning	8 - 4
8.03 Switching the machine on/off	8 - 4

Contents

	Contents	Chapter - Page
9	Setting up	9 - 1
9.01	Inserting the needle	9 - 1
9.02	Winding the bobbin thread, regulating the winder tension	9 - 2
9.03	Changing the bobbin	9 - 3
9.04	Threading the bobbin thread and regulating the bobbin thread tension	9 - 3
9.05	Threading needle thread/adjusting needle thread tension	9 - 4
10	Care and maintenance	10 - 1
10.01	Care and maintenance intervals	10 - 1
10.02	Cleaning	10 - 1
10.03	General oiling	10 - 2
10.04	Oiling the sewing hook	10 - 3
10.05	Oiling the needle-head parts	10 - 3
10.06	Checking/regulating the air pressure	10 - 4
10.07	Emptying/cleaning the water bowl of the air filter/regulator	10 - 4
11	Adjustment	11 - 1
11.01	Notes on adjustment	11 - 1
11.02	Tools, gauges and other equipment for adjusting	11 - 1
11.03	Abbreviations	11 - 1
11.04	Adjusting the basic machine	11 - 2
11.04.01	Position of the bottom feed dog crosswise to sewing direction	11 - 2
11.04.02	Adjusting the bottom feed dog in sewing direction	11 - 3
11.04.03	Needle position in needle hole	11 - 4
11.04.04	Needle height (preliminary adjustment)	11 - 5
11.04.05	Top-feed pendulum	11 - 6
11.04.06	Feeding stroke of top and bottom feeds	11 - 7
11.04.07	Top feed stroke	11 - 8
11.04.08	Top feed lifting motion	11 - 9
11.04.09	Hook clearance, needle rise and needle height	11 - 10
11.04.10	Needle-thread tension release	11 - 11
11.04.11	Thread check spring	11 - 12
11.04.12	Bobbin winder	11 - 13
11.04.13	Pressure of the lifting presser	11 - 14
11.05	Adjusting the thread trimmer -900/56	11 - 15
11.05.01	Control cam (preliminary adjustment)	11 - 15
11.05.02	Control lever height	11 - 16
11.05.03	Control pin	11 - 17
11.05.04	Engaging solenoid	11 - 18
11.05.05	Control pin height	11 - 19
11.05.06	Front position of thread catcher	11 - 20
11.05.07	Lateral position of thread catcher	11 - 21
11.05.08	Control cam (final adjustment)	11 - 22
11.05.09	Knife	11 - 23
11.05.10	Needle thread tension release	11 - 24

	Contents	Chapter - Page
11.05.11	Cutting test	11 - 25
11.05.12	Adjusting the synchronizer	11 - 26

1 Safety

1.01 Regulations

This machine has been made according to the European regulations indicated in the conformity and manufacturer's declarations.

In addition to this instruction manual, please also observe all generally accepted statutory and other legal requirements, including those of the user's country, and the valid pollution control regulations!

The locally valid regulations of the social insurance institution responsible for occupational accidents, or other supervisory authorities, must be strictly adhered to!

1.02 General notes on safety

- The machine must only be operated when the instruction manual has been fully read and understood, and only by operators who have had the necessary training!
- All notes on safety and the instruction manual of the motor manufacturer must be read before the machine is put into operation!
- All notices on the machine referring to danger and safety must be observed!
- The machine must be used for the purpose it is intended for and must not be operated without its safety devices; all regulations relevant to safety must be adhered to.
- When part sets are changed (e.g. needle, presser foot and needle plate), during threading, when the workplace is left unattended and during maintenance work, the machine must be isolated from the power supply by pressing the on/off switch or removing the plug from the mains!
- Daily maintenance work must only be carried out by appropriately trained persons!
- Repairs and special maintenance work must only be carried out by qualified technical staff or persons with the appropriate training! Exceptions to this are only allowed for adjustment and function checks by appropriately trained personnel!
- Repair work and special maintenance work must only be carried out by technical personnel or by persons with the appropriate training!
- Work on the electrical equipment must only be carried out by technical staff who are qualified to do so!
- Work on parts or equipment connected to the power supply is not permitted! The only exceptions to this are specified in regulations EN 50110.
- Conversion or modification of the machine must only be carried out under observation of all relevant safety regulations!

- Only spare parts which have been approved by us are to be used for repairs! We draw special attention to the fact that spare parts and accessories not supplied by us have not been subjected to testing nor approval by us. Fitting and/or use of any such parts may cause negative changes to the design properties of the machine. We shall not accept any liability for damage caused by the use of non-original parts.

1.03 Safety symbols



Danger!
Special points to observe.



Danger of injury to operating or technical staff!



Caution

Do not operate without finger guard and safety devices. Before threading, changing bobbin and needle, cleaning etc. switch off main switch.

1.04 Important notes for the user

- This instruction manual is part of the equipment of the machine and must be available to the operating staff at all times.
- The instruction manual must be read before the machine is operated for the first time.
- Both operating and technical staff must be instructed on the safety devices of the machine and on safe working methods.
- It is the duty of the user to operate the machine in perfect running order only.
- The user must ensure that none of the safety devices are removed nor put out of working order.
- The user must ensure that only authorized persons operate and work on the machine.

For further information please refer to your PFAFF agency.

1.05 Notes for operating and technical staff

1.05.01 Operating staff

Operating staff are the persons responsible for setting up, operating and cleaning the machine and for removing any disturbances in the sewing area.

The operating staff must be sure to observe the following items:

- always observe the notes on safety in this instruction manual in their work!
- refrain from any working methods which adversely effect the safety of the machine!
- avoid wearing loose clothing or jewelry such as necklaces or rings!
- also make sure that only authorised persons are allowed near the danger area of the machine
- immediately report to the user any changes to the machine that may affect its safety!

1.05.02 Technical staff

Technical staff are persons who have been trained in electrical engineering, electronics, pneumatics and mechanical engineering. They are responsible for lubricating, servicing, repairing and adjusting the machine.

The technical staff must be sure to observe the following items:

- always observe the notes on safety in this instruction manual in their work!
- press the on/off switch before carrying out adjustment and repair work, and ensure it cannot be switched on again unintentionally, or isolate the machine from the power supply by removing the mains plug!
- never work on parts or equipment still connected to the power supply! Exceptions to this are only permissible according to regulations EN 50110;
- replace all safety covers after carrying out maintenance or repair work and, if applicable, close the electrical control box again!

1.06 Danger warnings



A working area of 1 m must be kept free both in front of and behind the machine, so that easy access is possible at all times.



Never put your hands or fingers in the sewing area during sewing!
Danger of injury by the needle!

When a mechanically operated clutch motor without actuation lock is switched off, always wait until the motor has stopped! Danger of injury!



While setting or adjusting the machine do not leave any objects on the table nor in the needle plate area! Objects may be trapped or flung out of the machine!

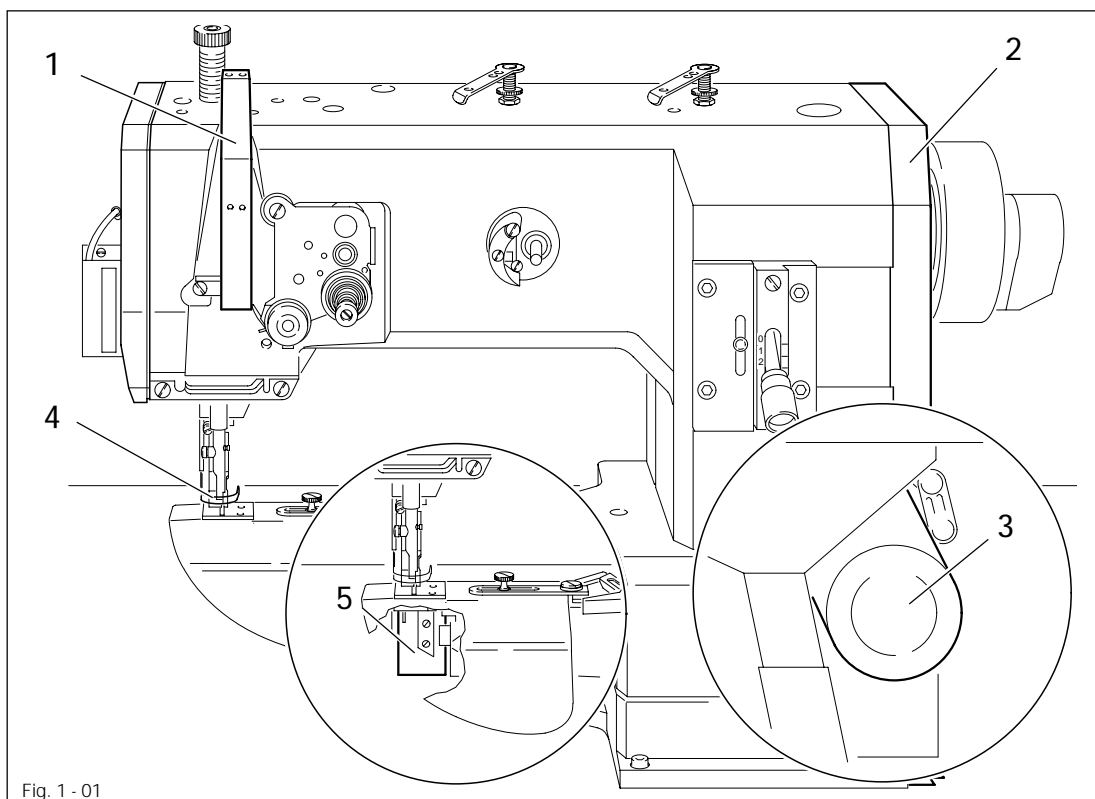

Fig. 1 - 01



Do not run the machine without take-up lever guard **1!**
Danger of injury by moving take-up lever!



Do not run the machine without belt guards **2 and 3!**
Danger of injury by rotating v-belt!



Do not run the machine without finger guard **4!**
Danger of injury by up and down movement of needle!



Do not run the machine without cylinder-bed cap **5!**
Danger of injury by rotating hook!

2

Proper use

The PFAFF 337 is a single-needle lockstitch cylinder-bed sewing machine with drop feed and variable top feed.

The machine is used for sewing sleeves into coats, costumes, jackets, etc., in the textile industry.



Any use of this machine which is not approved by the manufacturer shall be considered as improper use! The manufacturer shall not be held liable for any damage arising out of improper use! Proper use shall also be considered to include compliance with the operation, adjustment, service and repair measures specified by the manufacturer!

3 Specifications

3.01 PFAFF 337♦

Stitch type:	301 (lockstitch)
Machine model:	B
Needle system	134 – 35
Needle size in 1/100 mm:	80 to 100
Max. thread size (synthetic ▲)	40/3
Max. sewing speed*	2,100 s.p.m.
Effective dia. of balance wheel	80 mm
Dimensions of the machine:	
Cylinder-bed end dia.:	51 mm
Cylinder-bed circumference:	approx. 165 mm
Length:	approx. 770 mm
Breadth:	approx. 380 mm
Height (above table)	approx. 630 mm
Clear workspace length:	265 mm
Clear workspace height:	115 mm
Fabric clearance:	11 mm
Net weight (sewing head):	approx. 40 kg
Working air pressure:	6 bar
Air consumption:	~ 0.8 litres/work cycle
Mains voltage:	see instruction manual of motor
Max. power input:	see instruction manual of motor
Power supply fuse:	see instruction manual of motor
Ambient noise level:	
Workplace noise level at a speed of 1,800 r.p.m.	77 dB(A)
Noise measurement according to DIN 45636-48-A-1	

♦ Subject to technical alterations

▲ Or comparable sizes of other thread types

* Depending on material and operation

3.02 Possible versions and subclasses

Version B: For sewing medium materials

Work aids:

Subclass –921/01 Visual feed indicator

Subclass –900/51 Thread trimmer

4 Disposal of the machine

- The proper disposal of the machine is the responsibility of the customer.
- The materials used for the machine are steel, aluminium, brass and various plastics. The electrical equipment consists of plastics and copper.
- The machine must be disposed of in accordance with applicable local pollution control regulations. If necessary, a specialist is to be commissioned.



Special care is to be taken that parts soiled by lubricants are separately disposed of in accordance with the applicable local environmental pollution control!

5 Transportation, packing and storage

5.01 Transportation to customer's premises

Within the Federal Republic of Germany, complete machines (with table and motor) are delivered without packing.

Machines without table (only sewing heads) and machines intended for exports are packed.

5.02 Transportation inside the customer's premises

The manufacturer cannot be made liable for transportation inside the customer's premises nor to other operating locations.

5.03 Disposal of packing materials

The packing materials of this machine comprise paper, cardboard and VCE fibre. Proper disposal of the packing material is the responsibility of the customer.

5.04 Storage

If the machine is not in use, it can be stored as it is for a period of up to six months, but it should be protected against dust and moisture.

If the machine is stored for longer periods, the individual parts, especially the surfaces of moving parts, must be protected against corrosion, e.g. by a film of oil.

Explanation of the symbols

6 Explanation of the symbols

In this Instruction Manual, work to be carried out and important information are drawn to your attention by symbols. The symbols have the following meanings:



Note, information



Cleaning, care



Lubrication

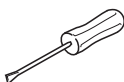

Servicing, repairing, adjustment, maintenance
(only to be carried out by specialist personnel)

7 Controls

7.01 On/off switch

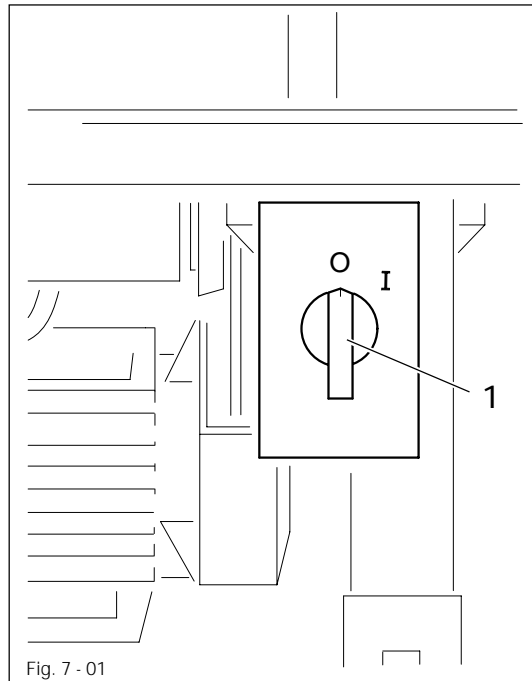

Fig. 7 - 01

- Switch the machine on or off by turning on/off switch 1.



The illustrated on/off switch is fitted to machines with Quick motors. If other motors are used, a different switch may be fitted.

7.02 Pedals

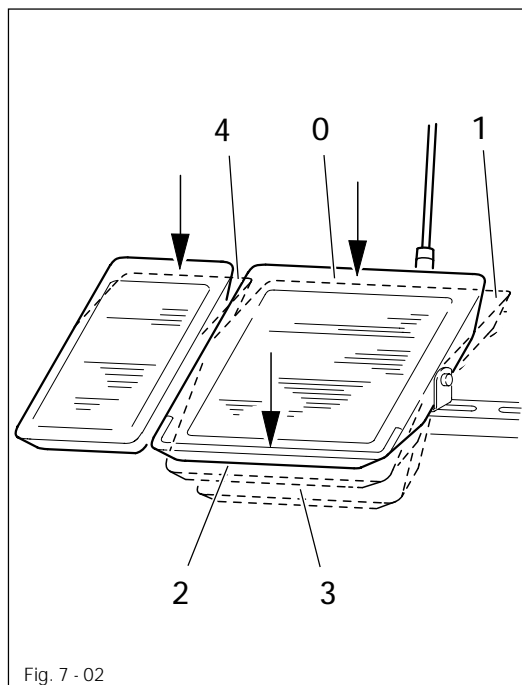

Fig. 7 - 02

- 0 = Neutral position
- 1 = Sewing
- 2 = Raise presser feet
- 3 = Thread trimming (on machines with thread trimmer -900/51)
- 4+1 = Increase stroke of top feed, see Chapter 7.05 Top feed stroke limitation.



For further pedal functions please refer to the instruction manual of the motor manufacturer.

7.03 Presser bar lifter

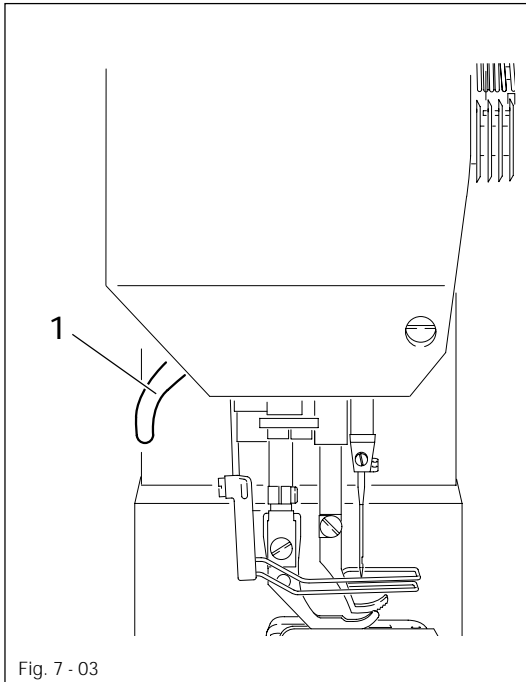

- To raise the lifting presser, raise lever 1.

7.04 Feed regulator lever

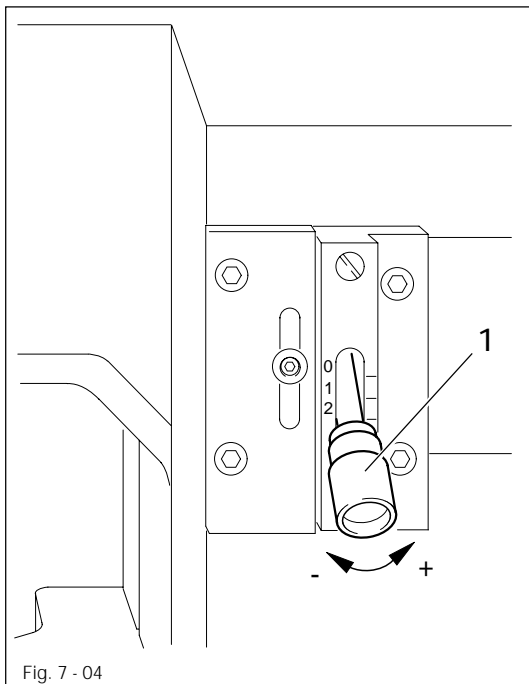

- To adjust the stitch length turn the knurled nut on lever 1.

7.05 Top feed stroke limitation

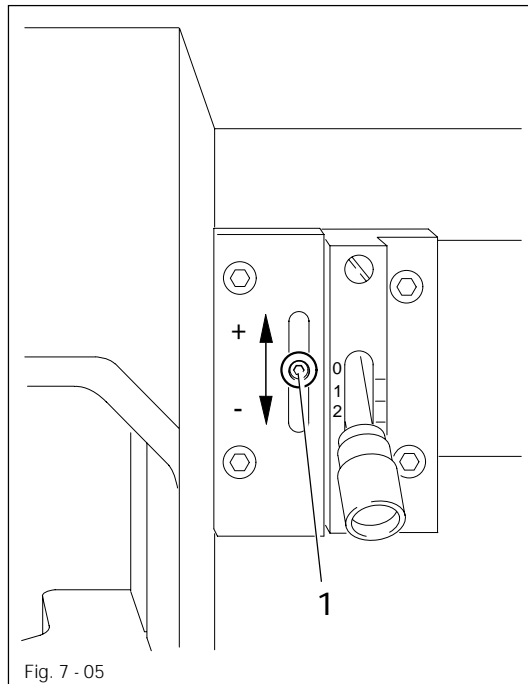

- To set the maximum top feed stroke, loosen the knurled nut and adjust lever 1.
- During sewing, the selected adjustment can be triggered by using the corresponding pedal function, see Chapter 7.02 Pedals.
- After adjustment, tighten the knurled nut again.

7.06 Visual indicator -921/01 (optional)

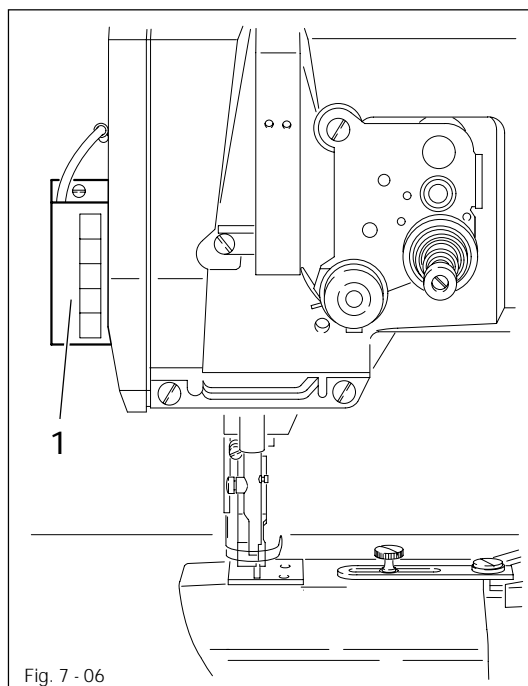

- When the left pedal is pressed, the visual indicator lights up (five light segments = maximum top feed stroke).

7.07

Top feed stroke adjustment

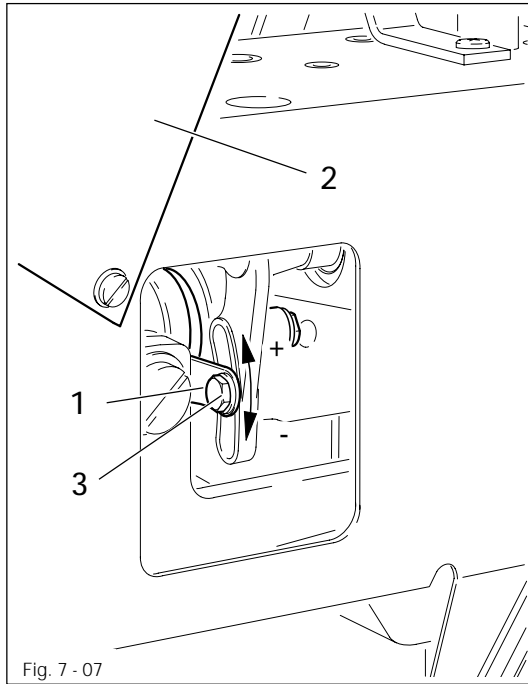

Switch off the machine!
Danger of injury due to
unintentional starting of the
machine!

- The top feed stroke is adjusted by repositioning lever 1. To do this, remove cover 2 at the rear side of the machine and loosen screw 3.
- After adjustment, tighten screw 3 and close cover 2.

8 Installation and commissioning



The machine must only be installed and commissioned by qualified personnel!
All relevant safety regulations must be strictly adhered to!



If the machine is delivered without a table, be sure to use a stand and table that will reliably support the weight of the machine with its motor.
It is very important to ensure that the stand of the machine is firm and steady, also during sewing.

8.01 Installation

The site where the machine is installed must be provided with suitable connections for electric current and compressed air. It must be ensured that the standing surface of the machine site is firm and horizontal and that sufficient lighting is available.



For packing and transportation reasons the table top is in the lowered position.
The table height is adjusted as described below.

8.01.01 Adjusting the table height

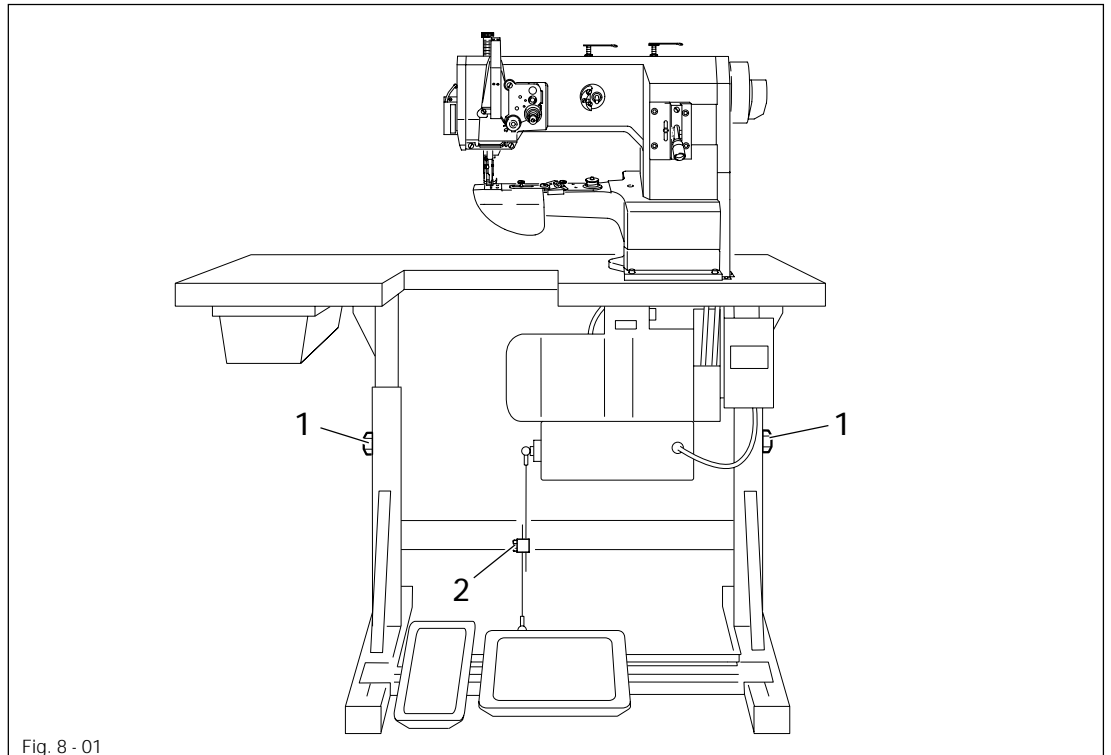
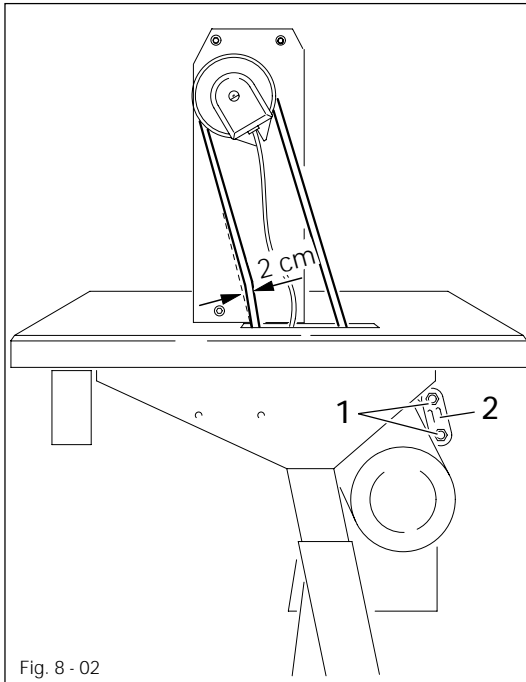

Fig. 8 - 01

- Loosen screws 1 and 2 and set the table at the required height.
- Fully tighten screw 1.
- Set the required pedal position and tighten screw 2.

Installation and commissioning

8.01.02 Tensioning the v-belt



- Loosen nuts 1.
- Tension v-belt by adjusting bracket 2.
- Tighten nuts 1.



Fig. 8-02 shows a Quick motor. If a different motor is used, please refer to the instruction manual of the motor manufacturer.

8.01.03 Fitting the upper belt guard

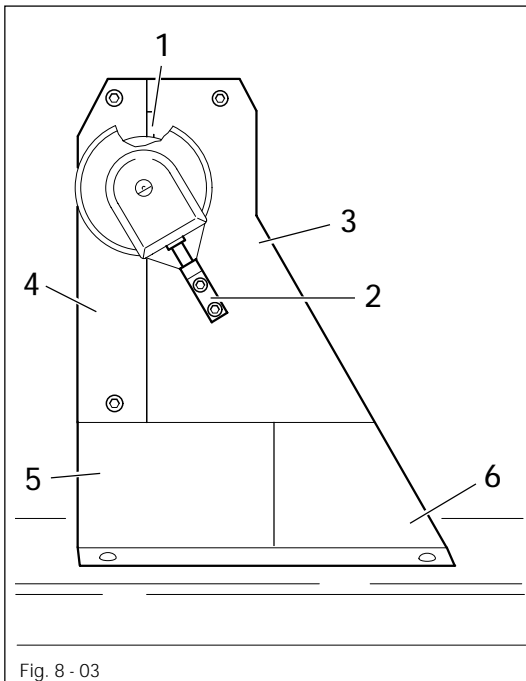

If a large balance wheel is in use, break off corner 1 of belt guard part 3.

- Screw stop piece 2 onto belt guard part 3.
- Screw on belt guard part 3 onto the housing.
- Screw on belt guard part 4 onto the housing.
- Secure belt guard parts 5 and 6 onto the table top.

8.01.04 Fitting the lower belt guard

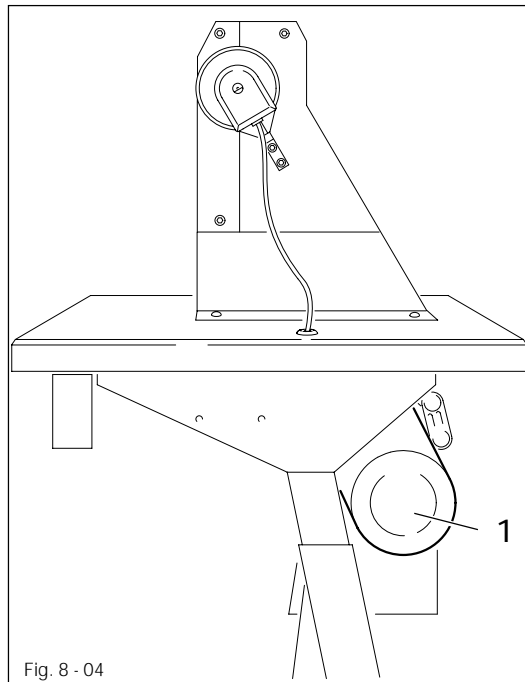

- Position belt guard 1 so that motor pulley and v-belt can run freely.



Fig. 8-02 shows a Quick motor. If a different motor is used, please refer to the instruction manual of the motor manufacturer.

8.01.05 Assembling the reel stand

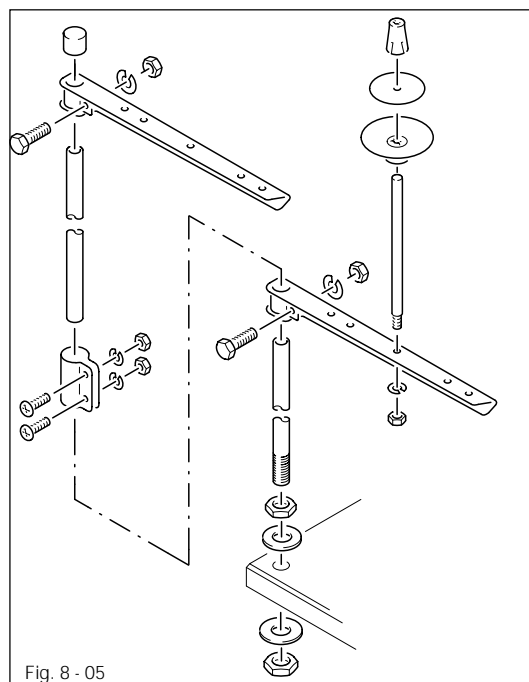

- Assemble the reel stand as shown in Fig. 8-05.
- Afterwards insert the stand in the hole in the table top and secure it with the nuts provided.

8.01.06 Fitting the sewing lamp▲

- Screw the sewing lamp onto the table top (wood screws 5 x 35) and have it connected by a mechanic.

▲ The sewing lamp is available as an option.

8.02 Commissioning

- Check the machine for any damage, particularly its electrical wiring and pneumatic tube connections.
- Clean the machine thoroughly and afterwards fill it with oil and oil the machine (see **Chapter 10, Care and maintenance**).
- Have a mechanic check whether the motor of the machine can be used with the available power supply and that the motor is correctly connected to the junction box. **Do not run the machine** if there is any discrepancy.
- When the machine is running, the balance wheel must turn towards the operator. If it does not, have the motor connection changed by a mechanic.
- Connect the machine to the compressed air supply. When it is connected, the gauge should show a pressure of **approx. 6 bar**. If necessary, have this reading correctly set (see **Chapter 10.07, Checking/adjusting the air pressure**).

8.03 Switching the machine on/off

- Switch the machine on/off (see **Chapter 7.01, On/off switch**).
- Carry out a running test.

9

Setting up



All instructions and regulations in this manual must be observed. Special attention must be given to all safety regulations!



All setting-up work must only be done by personnel with the necessary training. For all setting-up work the machine must be isolated from the power supply by turning off the on/off switch or removing the machine plug from the electric power socket!

9.01

Inserting the needle

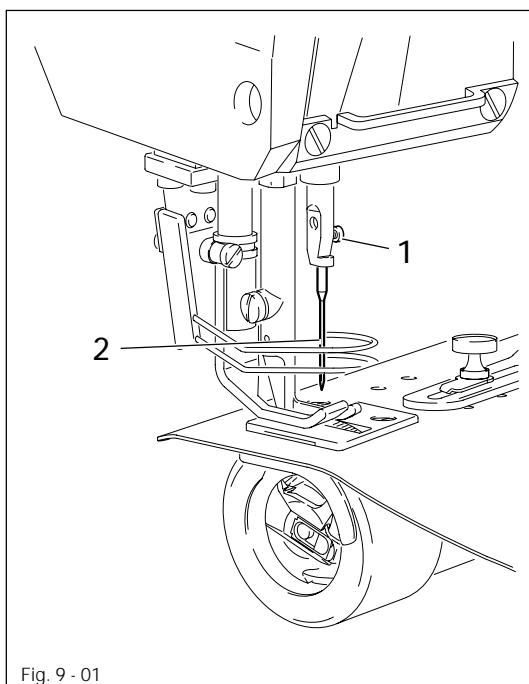

Fig. 9 - 01



Switch off the machine!
Danger of injury due to unintentional starting of the machine!

Only use needles of system 134-35.

- Set needle bar at top position and loosen screw 1.
- Push needle 2 fully in (the long needle groove must face to the left).
- Tighten screw 1 again.



The choice of needle depends on the version of the machine and the sewing thread and material in use (see **Chapter 3, Specifications**).

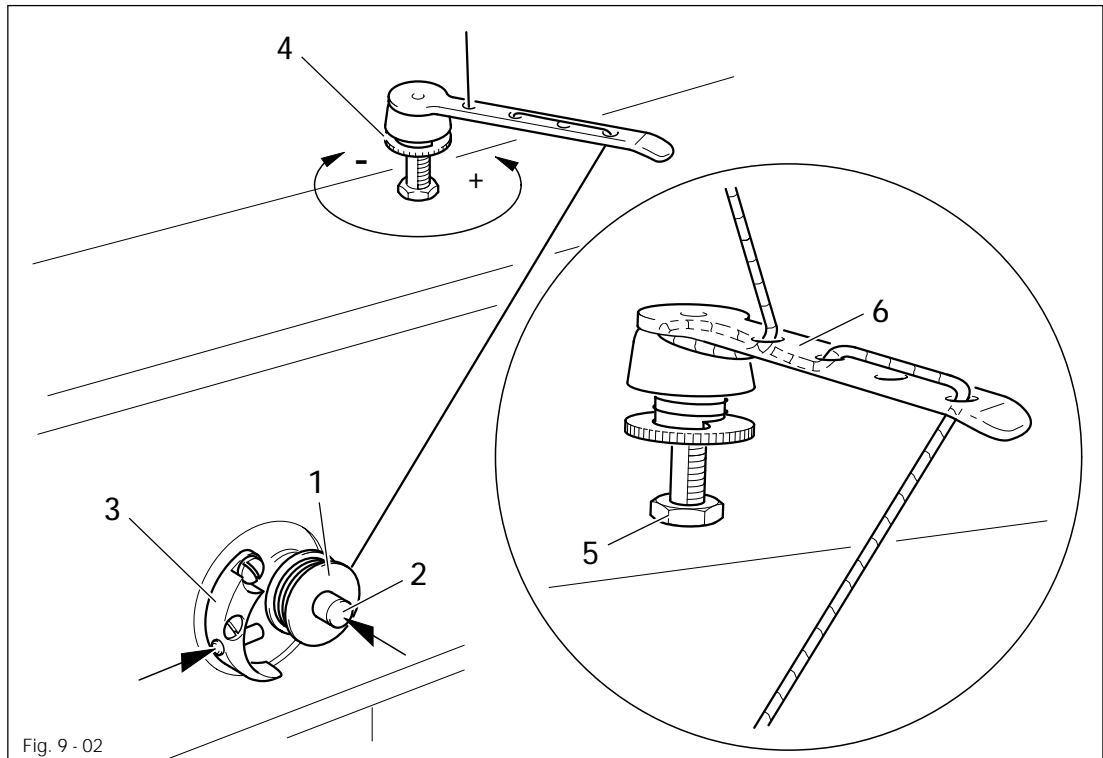

Fig. 9 - 02

- Place an empty bobbin 1 on winder spindle 2.
- Thread up as shown in Fig. 9-02 and wind the thread a few times clockwise around bobbin 1.
- Engage the bobbin winder by pressing spindle 2 and lever 3 simultaneously



The bobbin is wound during sewing.

- The tension of the thread wound onto bobbin 1 is set on knurled screw 4.
- The bobbin winder will stop when sufficient thread is wound onto bobbin 1.

If the thread is wound on unevenly:

- Loosen nut 5.
- Turn thread guide 6 as required.
- Tighten nut 5 again.

9.03 Changing the bobbin

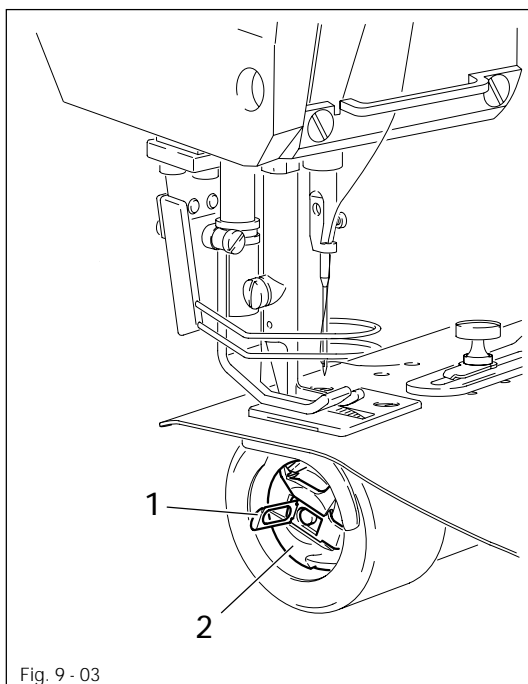

Fig. 9 - 03



Switch off the machine!
 Danger of injury due to
 unintentional starting of the
 machine!

Removing the bobbin case:

- Lift latch 1 and take out bobbin case 2.

Inserting the bobbin case:

- Insert full bobbin case so that you feel it snap in place.

9.04 Threading the bobbin thread and regulating the bobbin thread tension

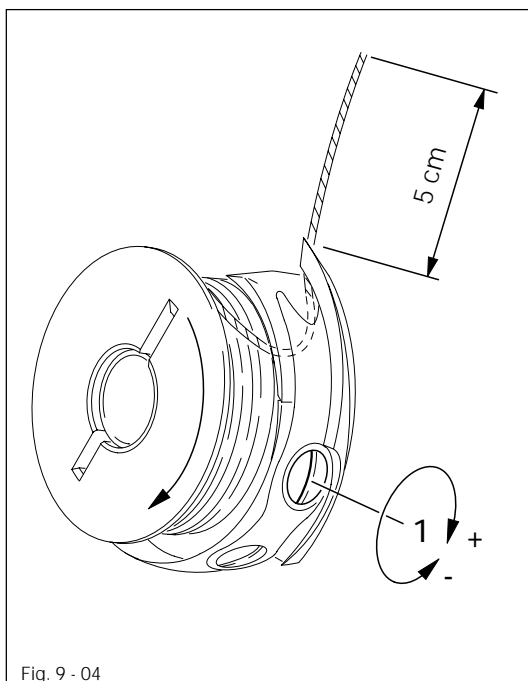

Fig. 9 - 04

- Thread the bobbin as shown in Fig. 9-04.
- When the thread is pulled, the bobbin must rotate as shown by the arrow.
- Regulate the bobbin thread tension on screw 1.

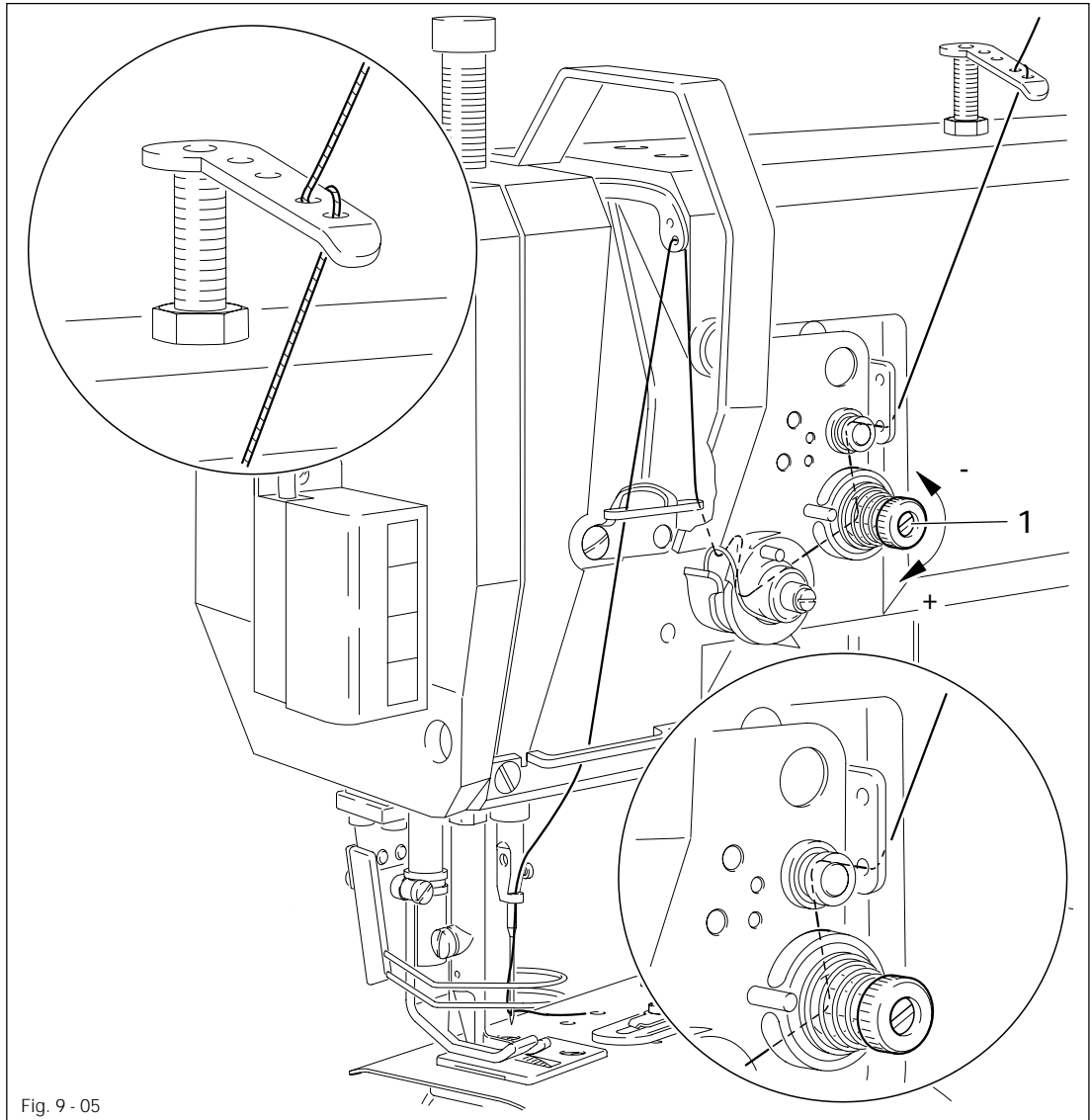

Fig. 9 - 05



Switch off the machine!

Danger of injury due to unintentional starting of the machine!

- Thread needle thread as shown in Fig. 9-05. Be sure to thread the needle from the left.
- Regulate the needle thread tension by turning knurled screw 1.

10 Care and maintenance

10.01 Care and maintenance intervals

Cleaning	daily, in continuous operation several times
Oil the hook	daily, before putting into operation
Check/adjust air pressure	daily, before putting into operation
Check water bowl of air filter/regulator	daily, before putting into operation
Clean hook	once a week
General oiling	twice a week
Oil needle-head parts	twice a week



The maintenance intervals in the table refer to the average machine running time in single-shift operation.
If the machine running time is longer than this, it is advisable to shorten these intervals.

10.02 Cleaning



Switch off the machine!
Danger of injury due to unintentional starting of the machine!

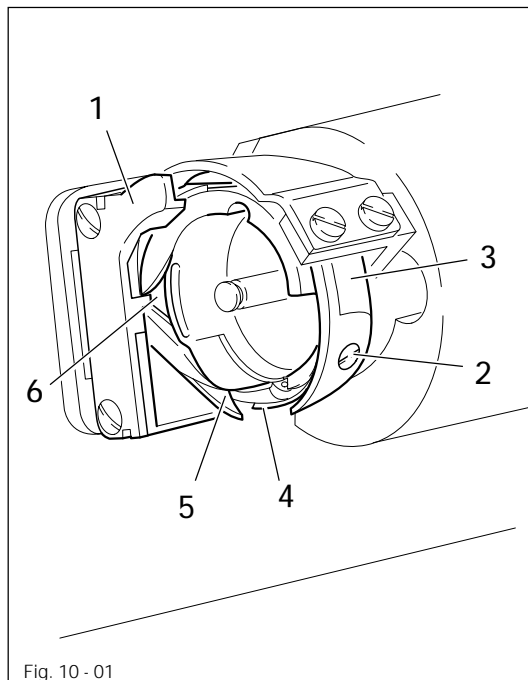

Fig. 10 - 01

Cleaning the hook area

- Clean hook area with a brush daily, in continuous operation several times daily.

Cleaning the hook

- Open cylinder-bed cap.
- Set needle bar at its highest position.
- Remove top of bobbin case together with bobbin
- Unscrew and remove bobbin case position stop 1.
- Remove screw 2 and take off hook gib 3.
- Turn balance wheel until point 4 is aligned with point 5.
- Take out bobbin case and clean hook race with petroleum spirit.
- When inserting the bobbin case, make sure that the lug on the rear side of bobbin case position stop 1 enters into groove 6.
- Screw on hook gib 3.
- Insert bobbin case and close cylinder-bed cap

10.03 General oiling

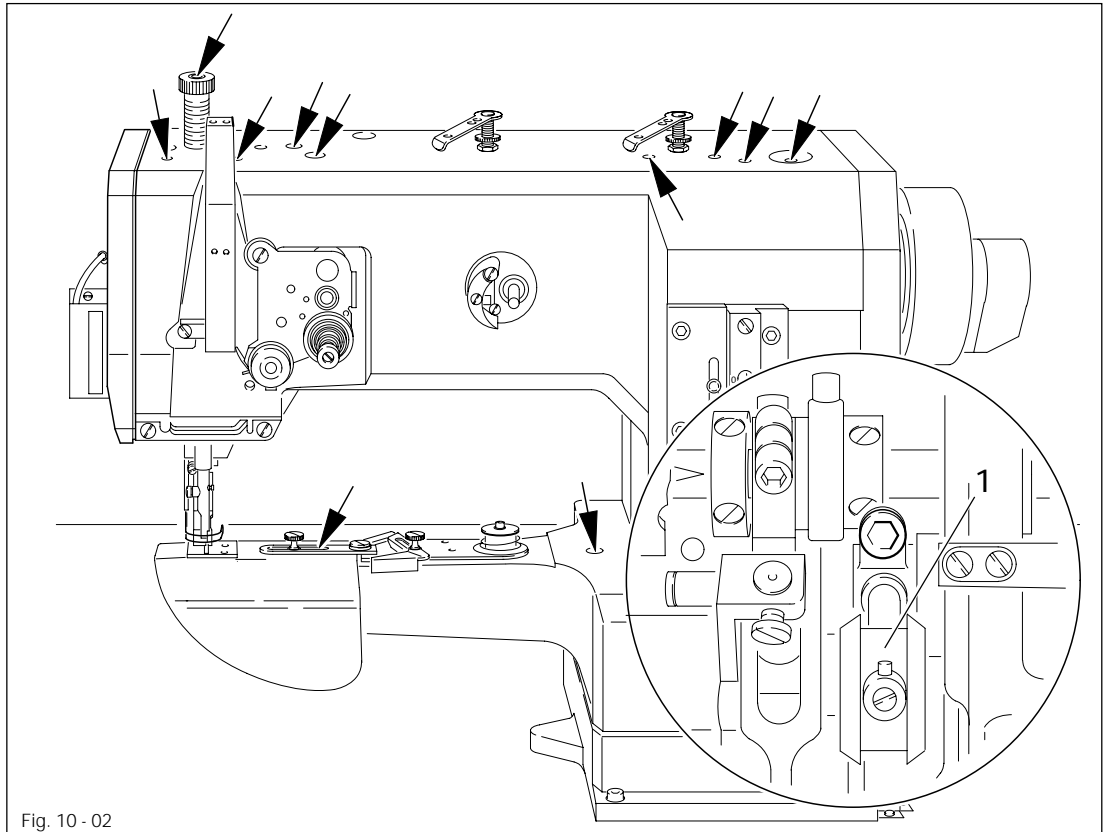

Fig. 10 - 02



Switch off machine!

Danger of injury by unintentional starting of the machine!

- Apply oil at all bearing points above the table (see arrows) and on bearing surface 1 at the rear of the machine twice a week.

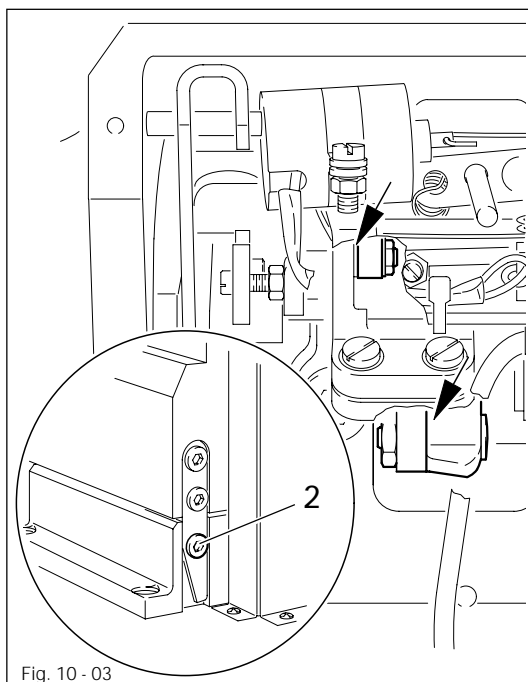

Fig. 10 - 03

- Remove screw 2 and tilt machine backwards.
- Apply oil at all bearing points beneath the table (see arrows) twice a week.



Set the machine upright with both hands! Danger of crushing between sewing head and table!

- Tighten screw 2 again.



Only use oil with a viscosity of 22.0 mm²/s at 40° C and a density of 0.865 g/cm³ at 15°C!

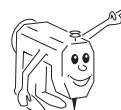

We recommend PFAFF sewing-machine oil, part No. 280-1-120144.

10.04 Oiling the sewing hook

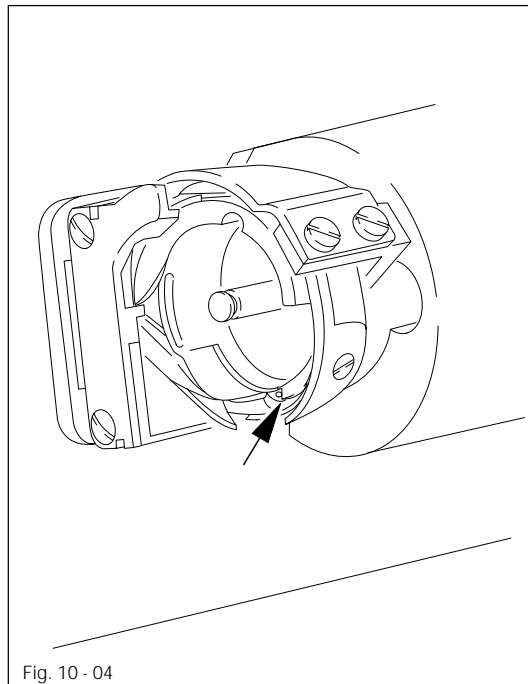

Switch off machine!
Danger of injury by
unintentional starting of the
machine!

- Open the cylinder-bed cap.
- Apply 1 or 2 drops of oil in hole 1 in the hook race (see arrow)..



Only use oil with a viscosity of
22.0 mm²/s at 40° C and a
density of 0.865 g/cm³ at 15°C!



We recommend PFAFF sewing-
machine oil, part
No. 280-1-120144.

10.05 Oiling the needle-head parts

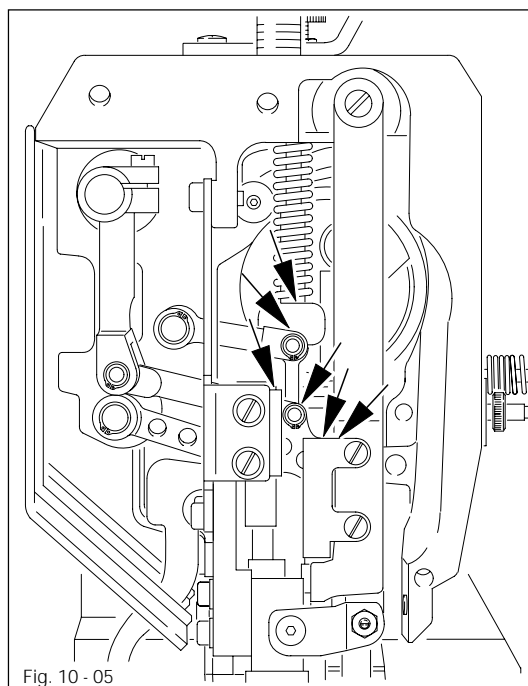

Switch off machine!
Danger of injury by
unintentional starting of the
machine!

- Remove the faceplate.
- Oil all moving parts and bearing points (see arrows) twice a week.
- Refit the faceplate.



Only use oil with a viscosity of
22.0 mm²/s at 40° C and a
density of 0.865 g/cm³ at 15°C!

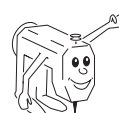

We recommend PFAFF sewing-
machine oil, part
No. 280-1-120144.

10.06 Checking/regulating the air pressure

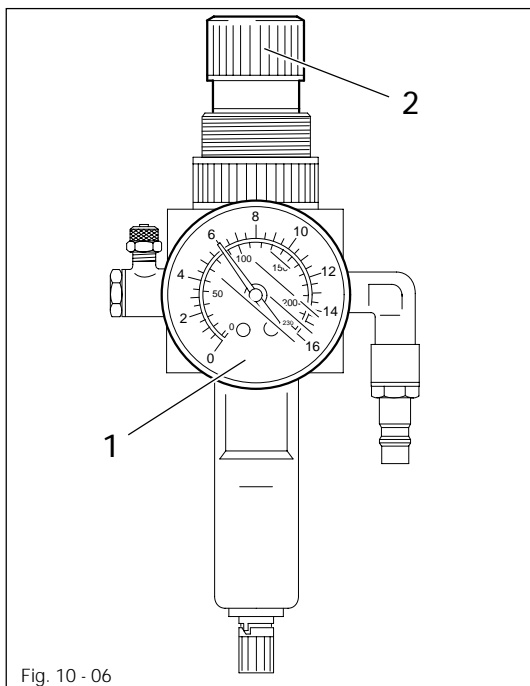

- Check the air pressure on gauge 1 every time before operation.
- Gauge 1 must show a pressure of 6 bar.
- Regulate this pressure if required.
To do so, pull knob 2 up and turn it accordingly.

10.07 Emptying/cleaning the water bowl of the air filter/regulator

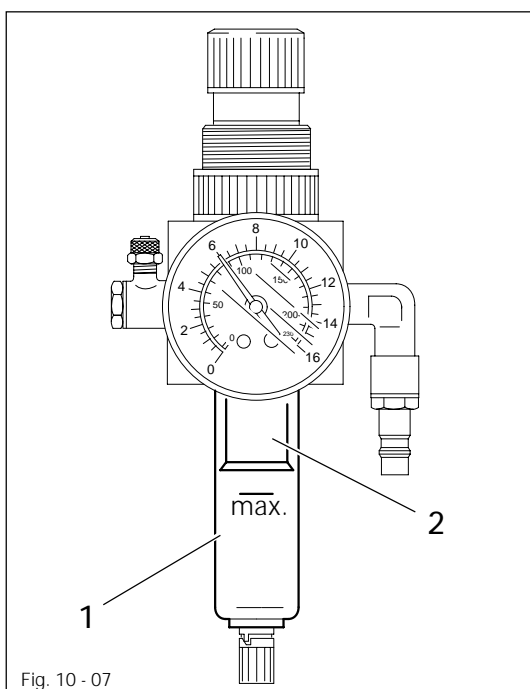

Switch off the machine.
Disconnect the air hose at the
air filter/regulating unit.

Emptying the water bowl

- Water bowl 1 empties itself automatically when the air hose is disconnected from the air filter/regulator.

Cleaning the filter

- Unscrew water bowl 1 and take out filter 2.
- Clean the filter with compressed air or with isopropyl-alcohol, part number 95-665735-91.
- Screw in filter 2 and screw on water bowl 1.

11 Adjustment

11.01 Notes on adjustment

All adjustments in this instruction manual refer to a completely assembled machine and must only be carried out by **appropriately trained technical personnel**. Machine covers that have to be removed and replaced for checks and adjustment work are not mentioned in the text.

The screws and nuts indicated in brackets () are for the fixation of machine parts that have to be unscrewed before adjustment and tightened again afterwards.

11.02 Tools, gauges and other equipment for adjusting

- Screwdrivers with blade widths from 2 to 10 mm
- Spanners (wrenches) in sizes from 7 to 14 mm
- Allen keys from 2 to 6 mm
- Metal rule (part No. 08-880218-00)
- Needle-rise gauge (part No. 61-111600-01)
- Screw clamp (part No. 61-111600-35/001)
- Gauge, 7-mm, for lifting presser stroke (part No. 61-111630-14)
- Needles, system 134-35
- Sewing thread and material for stitching off

11.03 Abbreviations

t.d.c. = top dead centre

b.d.c. = bottom dead centre

Adjustment

11.04 Adjusting the basic machine

11.04.01 Position of the bottom feed dog crosswise to sewing direction

Requirement

The bottom feed dog 1 must clear the feed slot by the same amount at the left and right.

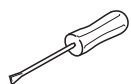
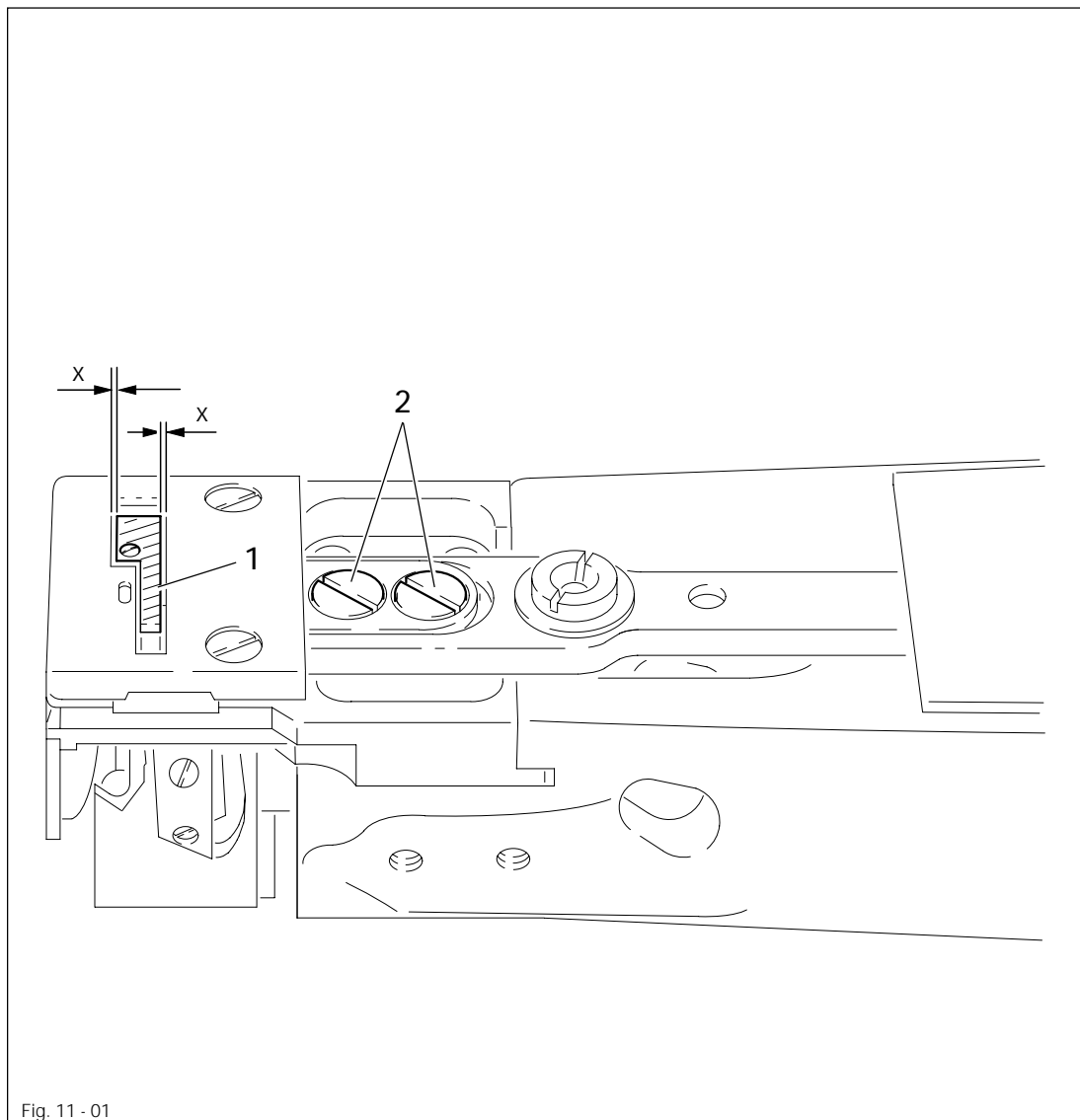

- Re-position feed dog 1 (screws 2) according to Requirement.

11.04.02 Adjusting the bottom feed dog in sewing direction

Requirement

With the longest stitch length set, bottom feed dog 5 must clear the feed slot by the same amount at the front and rear end of its stroke.

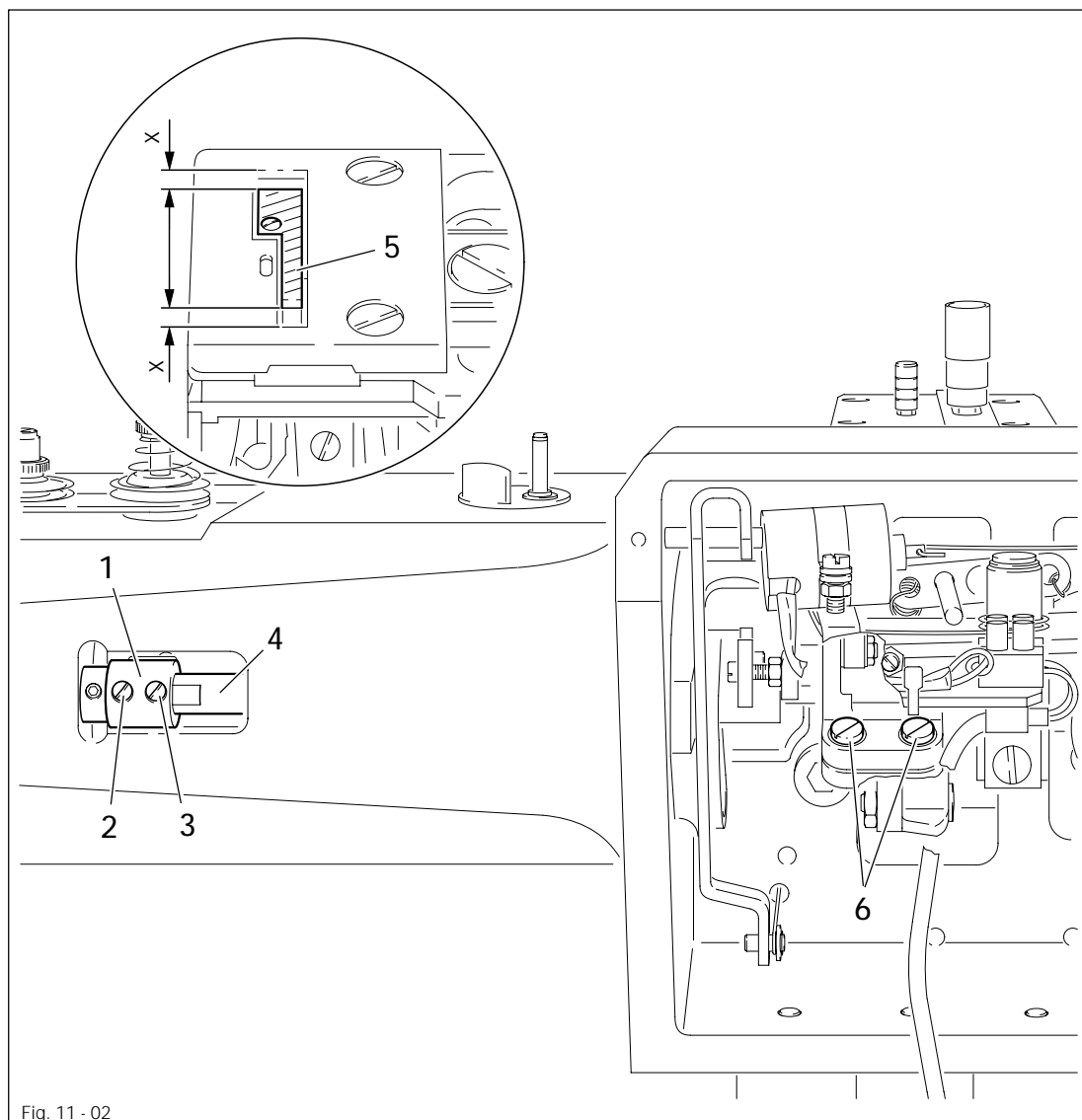
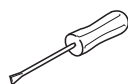

Fig. 11 - 02



- Set the longest stitch length.
- Position clamp sleeve 1 (screws 2 and 3) on the flat of shaft 4 as far to the left as possible, making sure that screw 2 is still on the flat.
- Position feed dog 5 (screws 6) according to **Requirement**.

11.04.03 Needle position in needle hole

Requirement

1. In sewing direction the needle centre must be at a distance of approx. **0.7 mm** from the front inside edge of the needle hole.
2. Crosswise to sewing direction the needle must be centred in the needle hole.

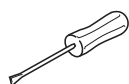
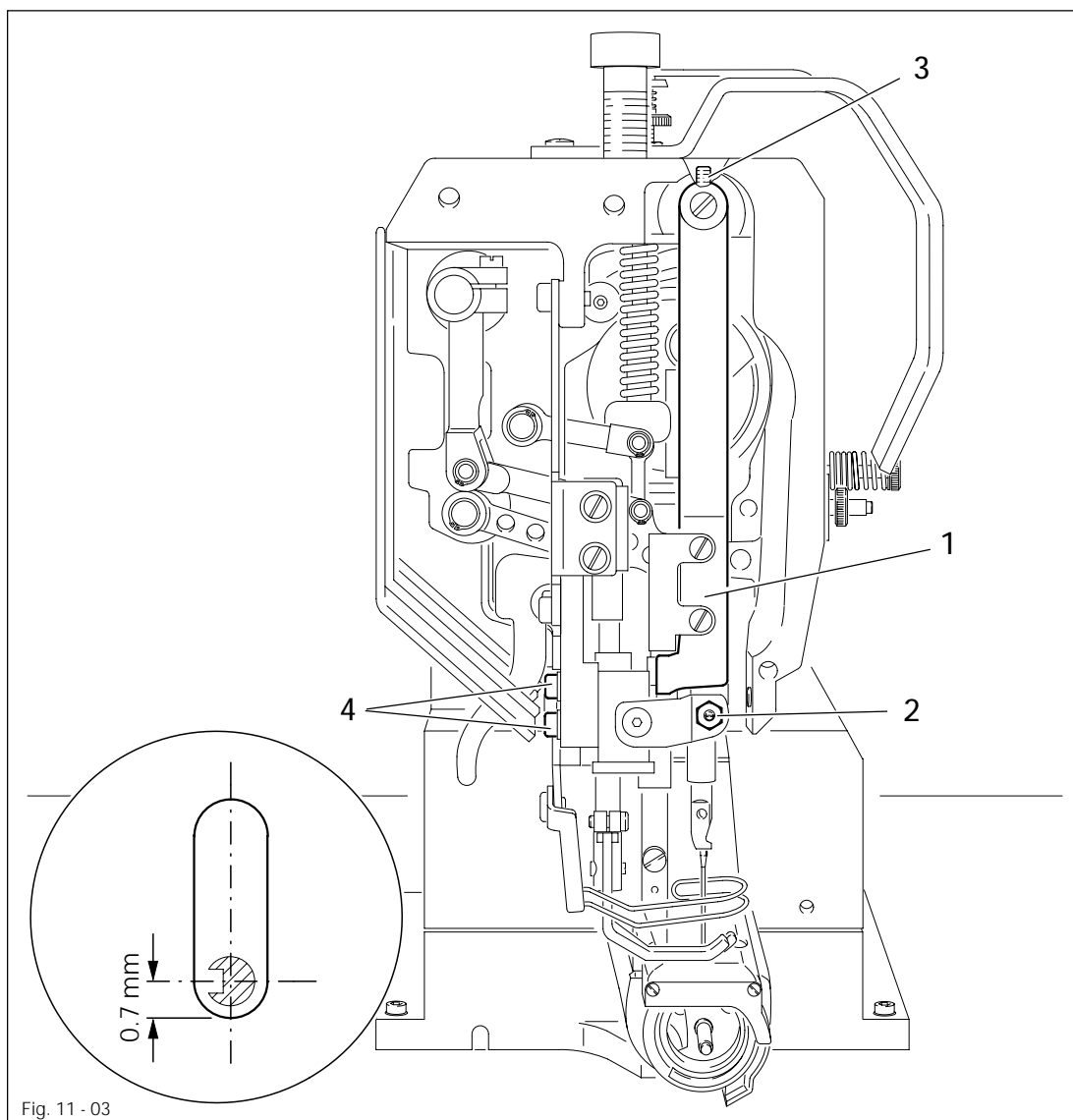

- Turn the balance wheel to lower the needle into the needle plate.
- Position needle-bar frame 1 (nut 2 with locknut) according to Requirement 1.
- Position needle-bar frame 1 (screws 3 and 4) according to Requirement 2.

11.04.04 Needle height (preliminary adjustment)

Requirement

With the needle bar at b.d.c. the clearance between needle bar and needle plate must be 15 mm.

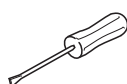
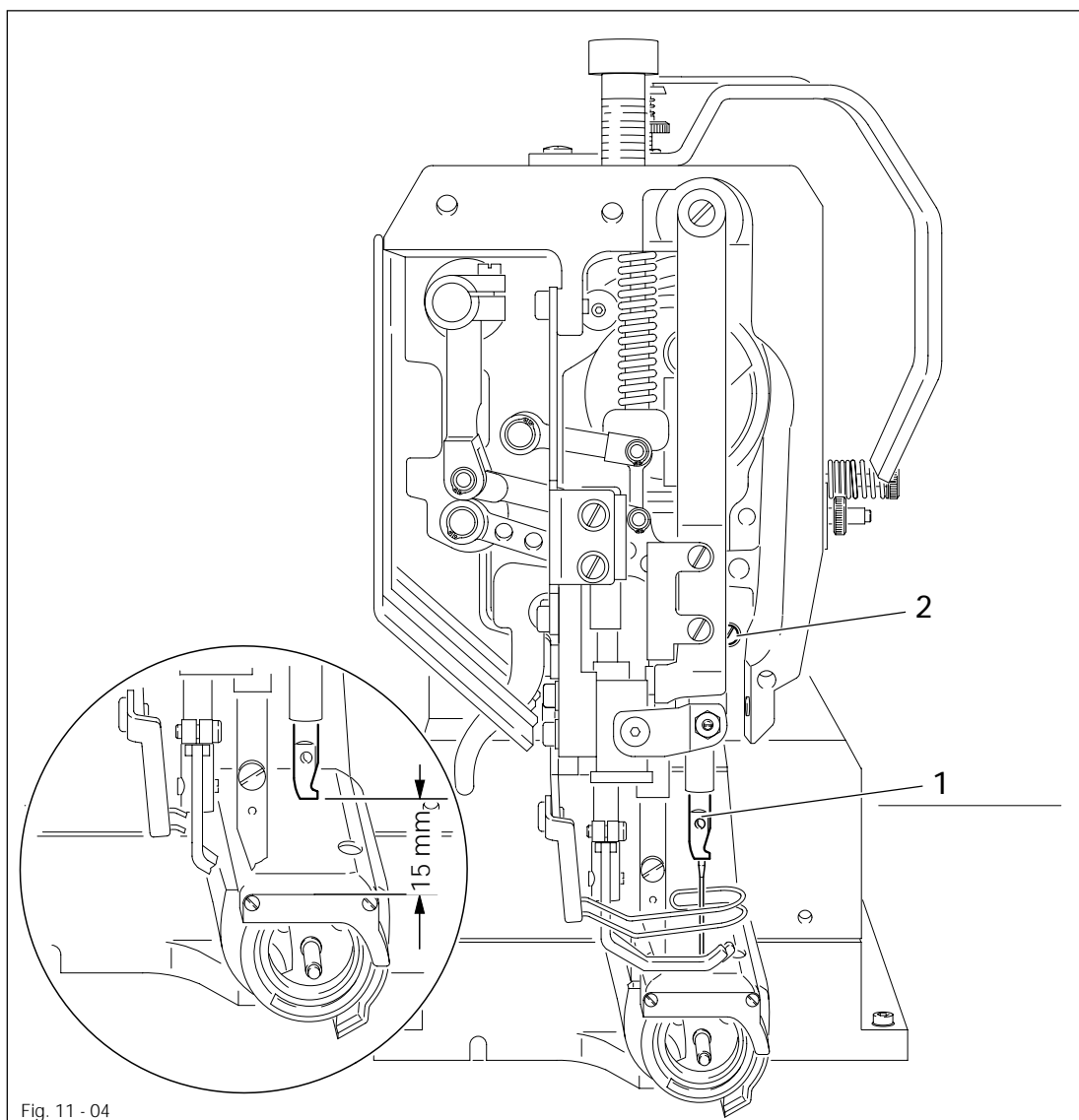

- Position the height of needle bar 1 (screws 2) according to **Requirement**, but do not turn it.

Adjustment

11.04.05 Top-feed pendulum

Requirement

At stitch length "0" and the largest gather setting, presser bar 4 must be at the centre between needle bar guide and presser bar.

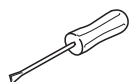
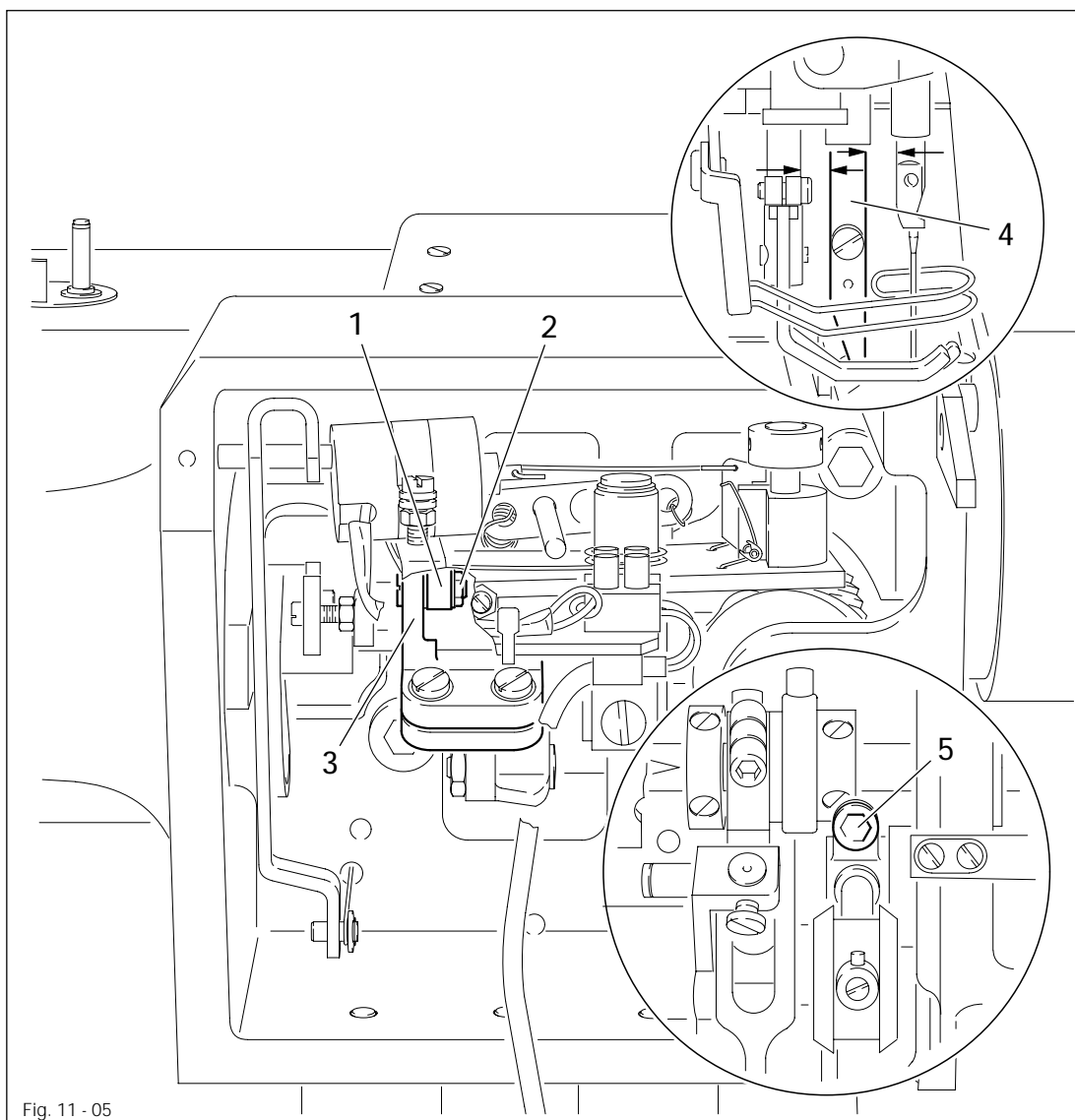

- Push linkage rod 1 (screw 2) fully up in its slot 3.
- Set stitch length at "0" and press the pedal to set the largest gather setting.
- Position presser bar 4 (screw 5) according to **Requirement**.

11.04.06 Feeding stroke of top and bottom feeds

Requirement

When the lower edge of the descending needle bar is **33 mm** above the top edge of the needle plate, the top and bottom feeds should not move when the stitch length adjustment lever is activated.

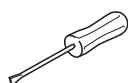
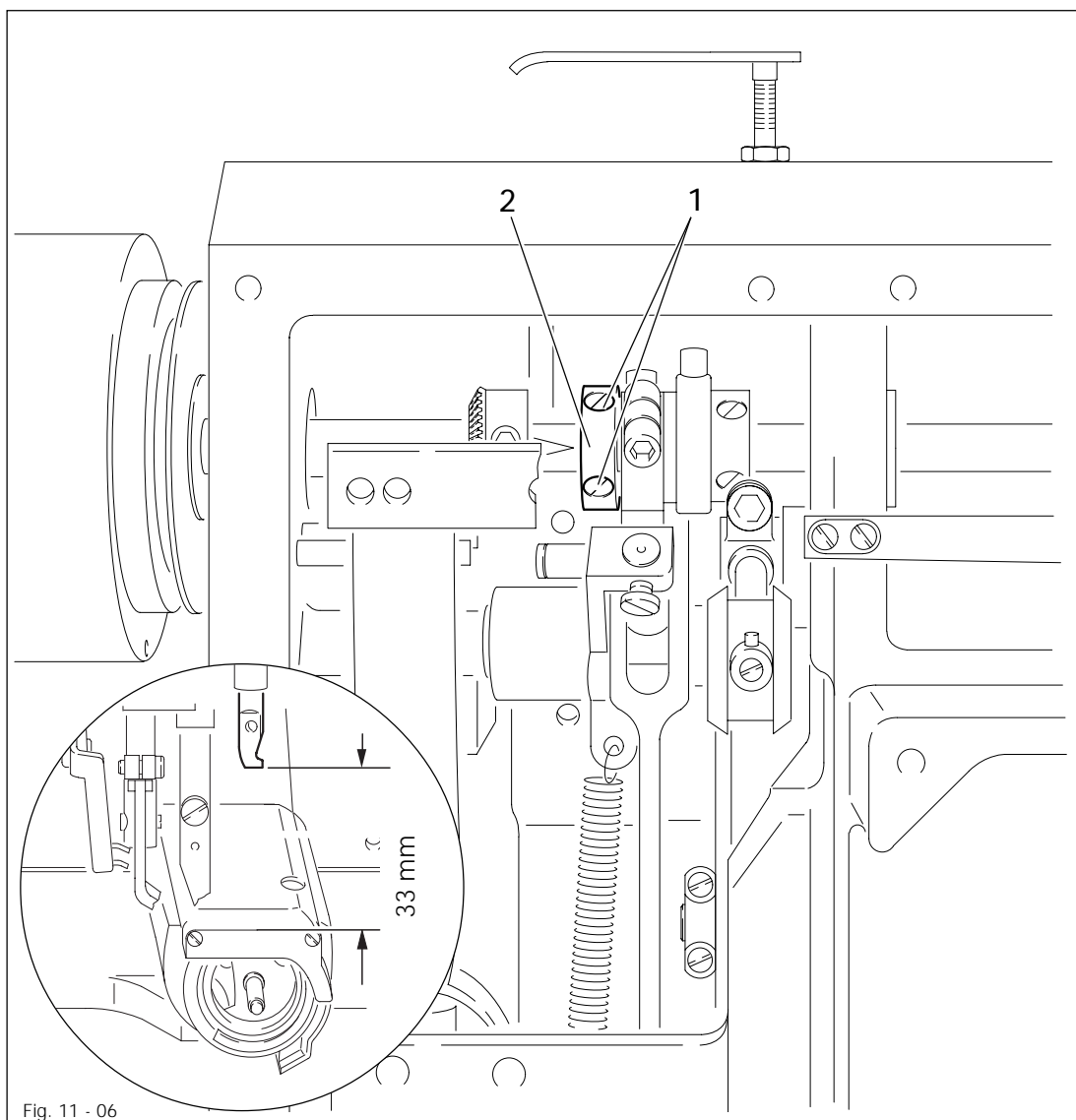

- Set the longest stitch length.
- Loosen screws 1 far enough, so that the eccentric 2 can be turned on the shaft with difficulty.
- Bring the needle bar into the appropriate position.
- Turn eccentric 2 according to the requirement.
- Tighten screws 1.

Adjustment

11.04.07 Top feed stroke

Requirement

When lever 1 is in the middle of its slot, vibrating presser 3 and lifting presser 4 must be at the same height above the needle plate.

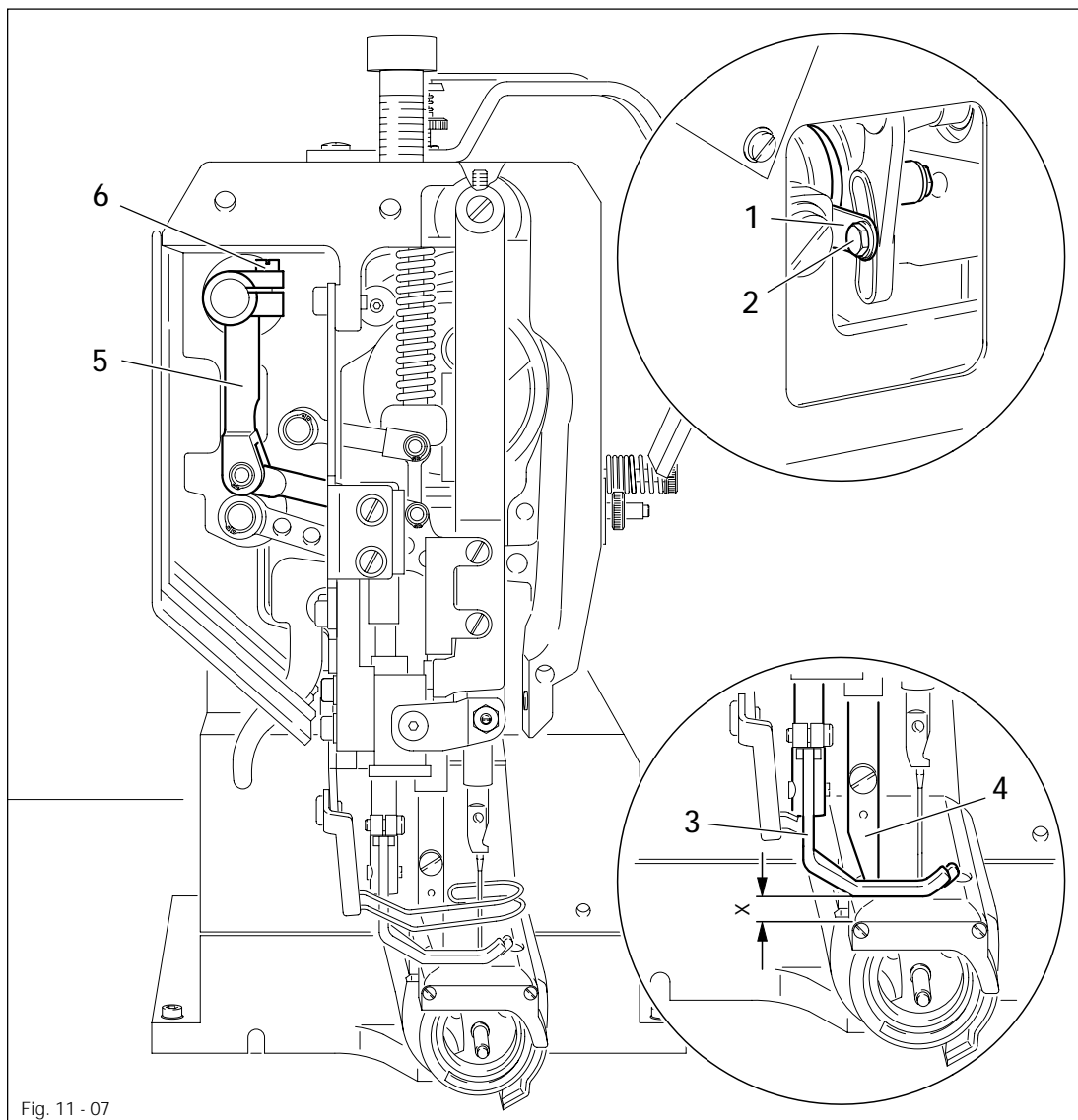
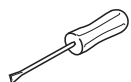

Fig. 11 - 07



- Set stitch length at "0"
- Set lever 1 (screw 2) at the middle of its slot.
- Lower lifting presser 3.
- Turn balance wheel in sewing direction until vibrating presser 4 is at its highest point.
- Turn crank 5 (screw 6) according to **Requirement**

11.04.08 Top feed lifting motion

Requirement

When the lower edge of the descending needle bar is 33 mm above the top edge of the needle plate, the top feed should not move, when the slotted lever 3 is moving up and down.

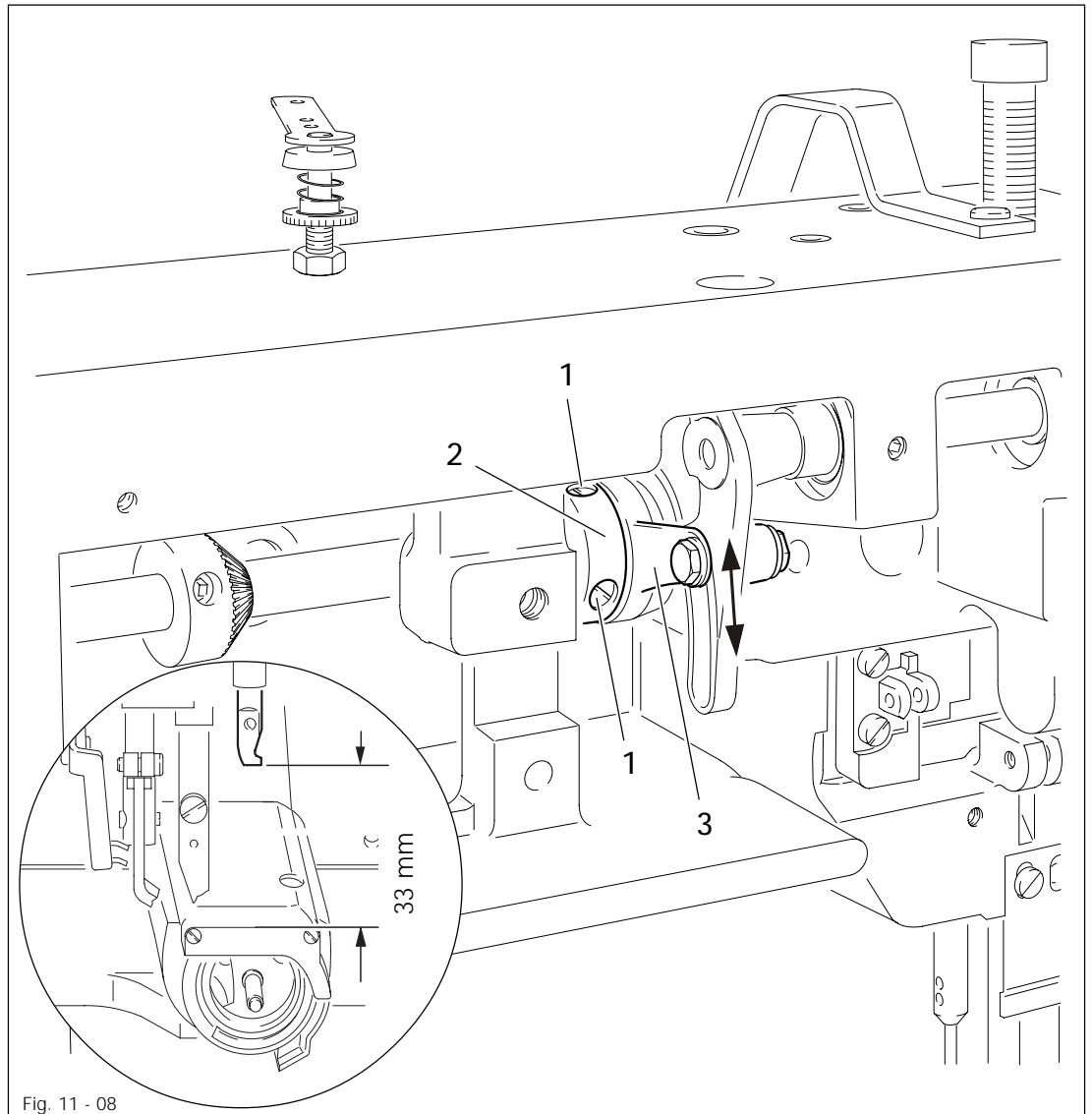
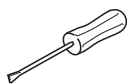

Fig. 11 - 08



- Loosen screws 1 far enough, so that the eccentric 2 can be turned on the shaft with difficulty.
- Bring the needle bar into the appropriate position.
- Turn eccentric 2 according to the requirement.
- Tighten screws 1.

11.04.09 Hook clearance, needle rise and needle height

Requirement

With the longest stitch length set and in needle-rise position (= 1.8 mm past b.d.c. of the needle bar)

1. The hook point must be at "needle centre" and the clearance between hook and needle 0.05 to 0.1 mm, and
2. the top of the needle eye must be 0.8 mm below the hook point.

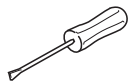
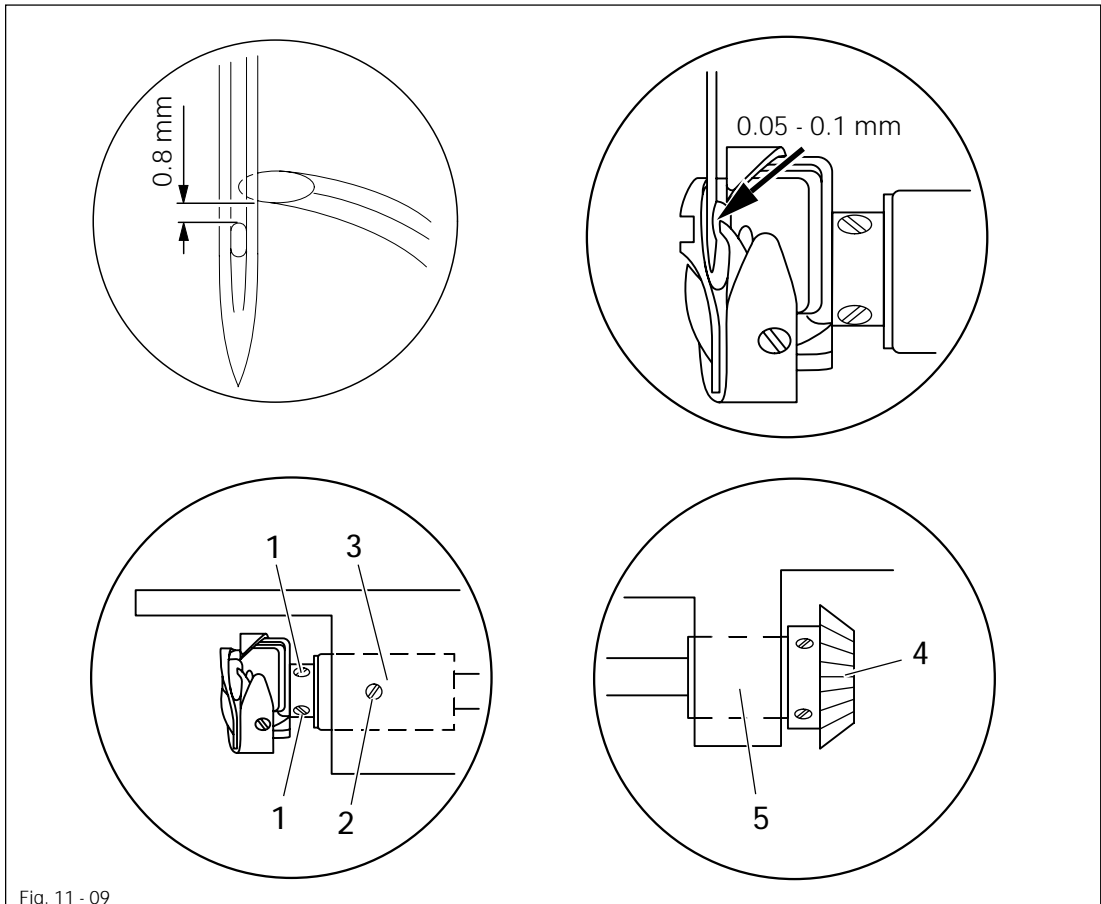

- Set the longest stitch.
- Loosen screws 1 and 2 (screw 2 is on the rear side of the machine).
- Set the needle bar at b.d.c. and place the 1.8 mm thick feeler gauge with its cutout close under the lower needle bar bearing.
- Place the screw clamp up against the feeler gauge and tighten it.
- Remove the feeler gauge and turn the balance wheel until the screw clamp is resting against the needle bar bearing.
- Adjust the hook according to **Requirements**.
- If necessary adjust the needle height, see **Chapter 11.04.04 Needle height (preliminary adjustment)**.
- Move hook shaft bearing 3 against the hook and tighten screw 2.
- Move bevel gear 4 against bearing 5 and tighten screws 1.



On machines with thread trimmer –900/51, adjustment of the axial play of the hook shaft and hook-shaft bearing 3 does not apply.

11.04.10 Needle-thread tension release

Requirement

With the lifting presser raised, there must be a clearance of at least 0.5 mm between tension discs 4.

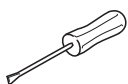
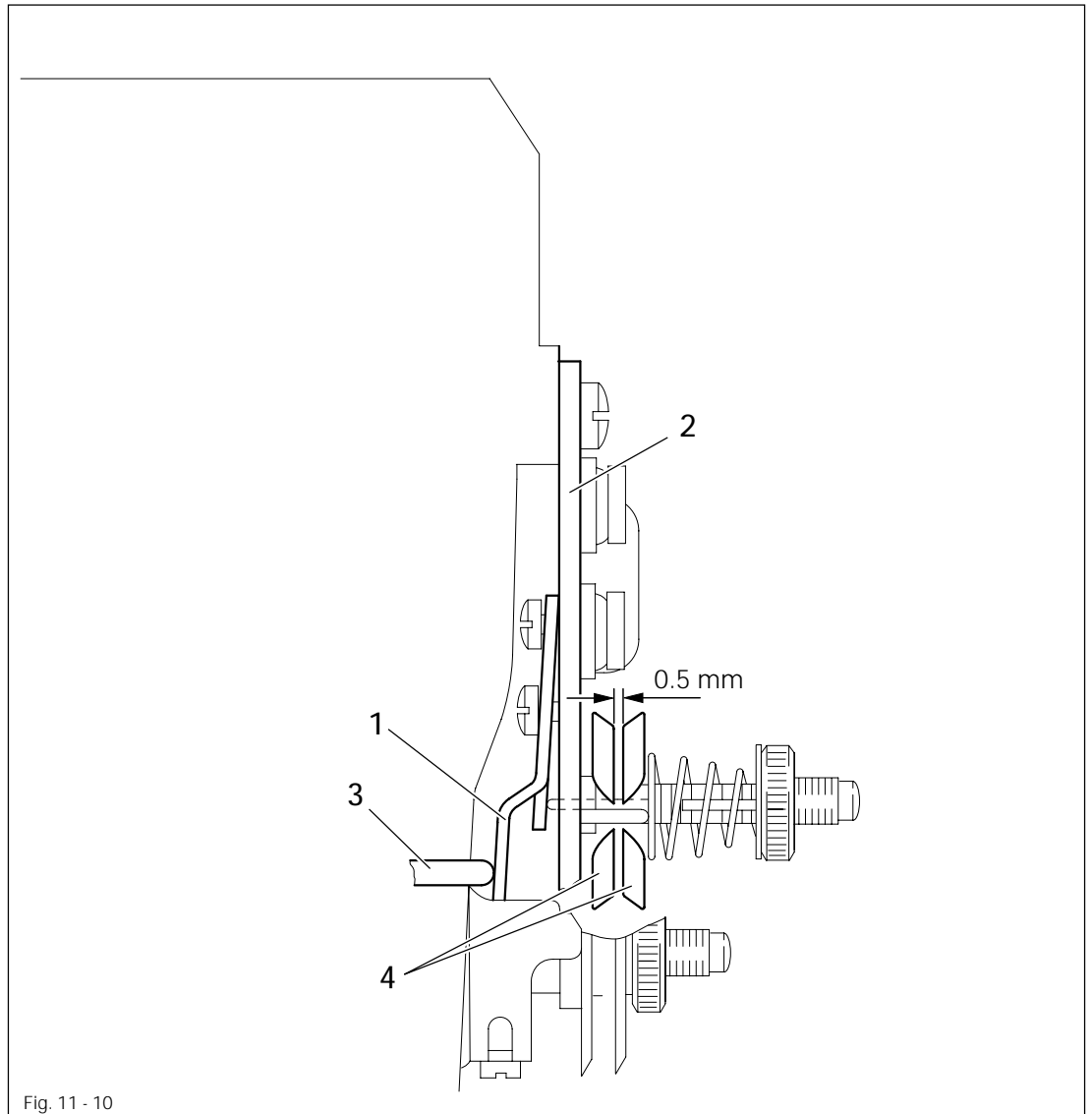

- Raise the lifting presser.
- Position pressure plate 1 behind mounting bracket 2 according to Requirement.



When the tension is engaged, release pin 3 must not be under load.

Adjustment

11.04.11 Thread check spring

Requirement

The movement of thread check spring 5 must be finished when the needle point enters the material (= spring stroke of about 7 mm).

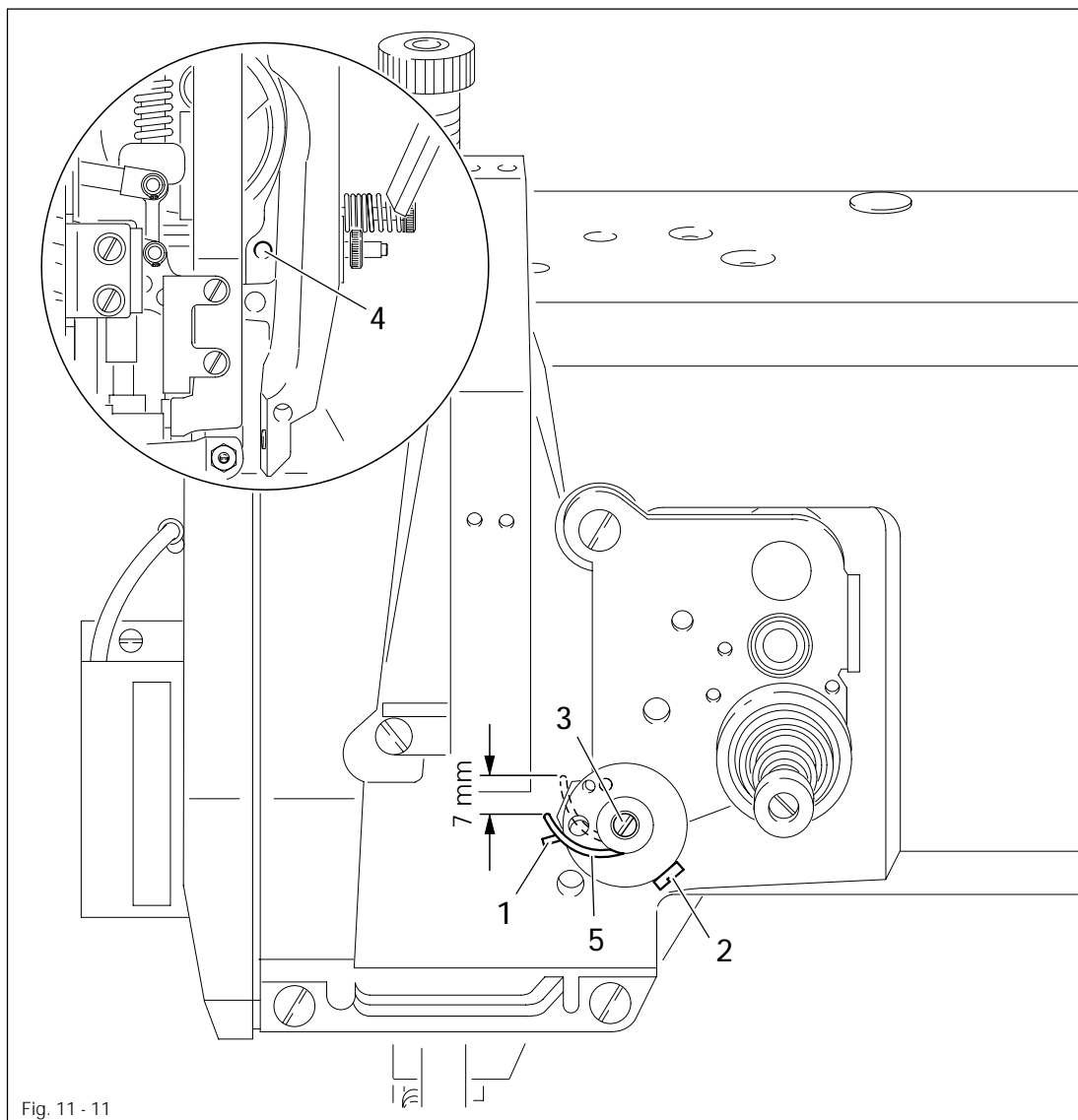
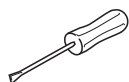

Fig. 11 - 11



- Adjust stop 1 (screw 2) according to **Requirement**.
- To adjust the pressure of the spring, turn screw 3 (screw 4).



For technical reasons the length of the thread check spring stroke may vary upwards or downwards a little.

11.04.12 Bobbin winder

Requirement

1. With the bobbin winder engaged, friction wheel 5 must be driven reliably.
2. With the bobbin winder disengaged, friction wheel 5 must not run against drive wheel 1.
3. The bobbin winder must switch itself off when the filled thread is about 1 mm from the rim of the bobbin.

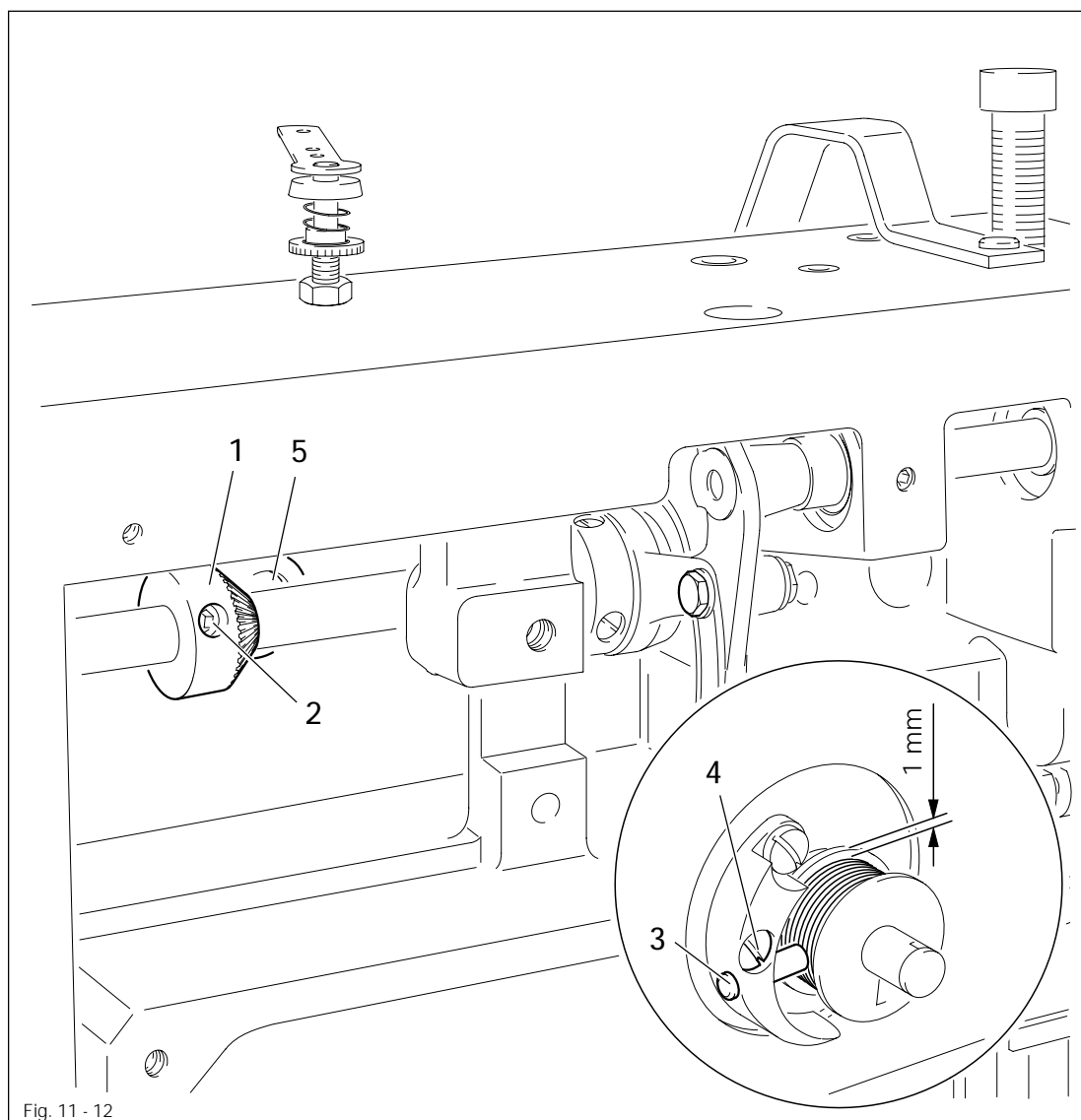
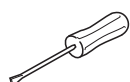

Fig. 11 - 12



- Position drive wheel 1 (screws 2) according to Requirements 1 and 2.
- Position pin 3 (screw 4) according to Requirement 3.

Adjustment

11.04.13 Pressure of the lifting presser

Requirement

The material must be properly fed, even at the highest sewing speed.

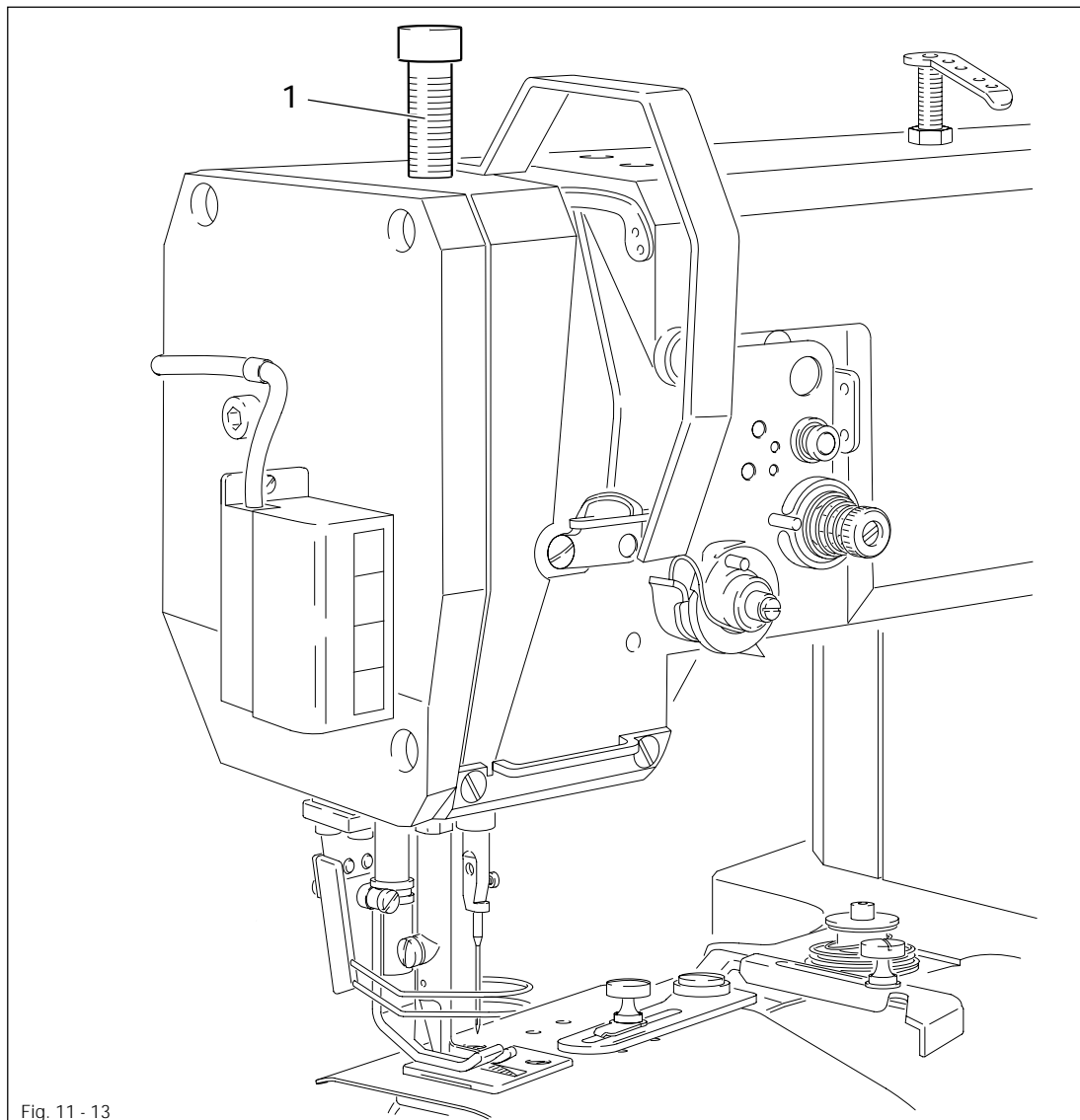
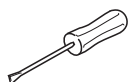

Fig. 11 - 13



- Turn screw 1 according to the Requirement.

11.05 Adjusting the thread trimmer -900/56

11.05.01 Control cam (preliminary adjustment)

Requirement

With the needle bar at b.d.c., groove 4 of control cam 2 must be vertically below control pin 5.

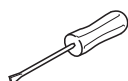
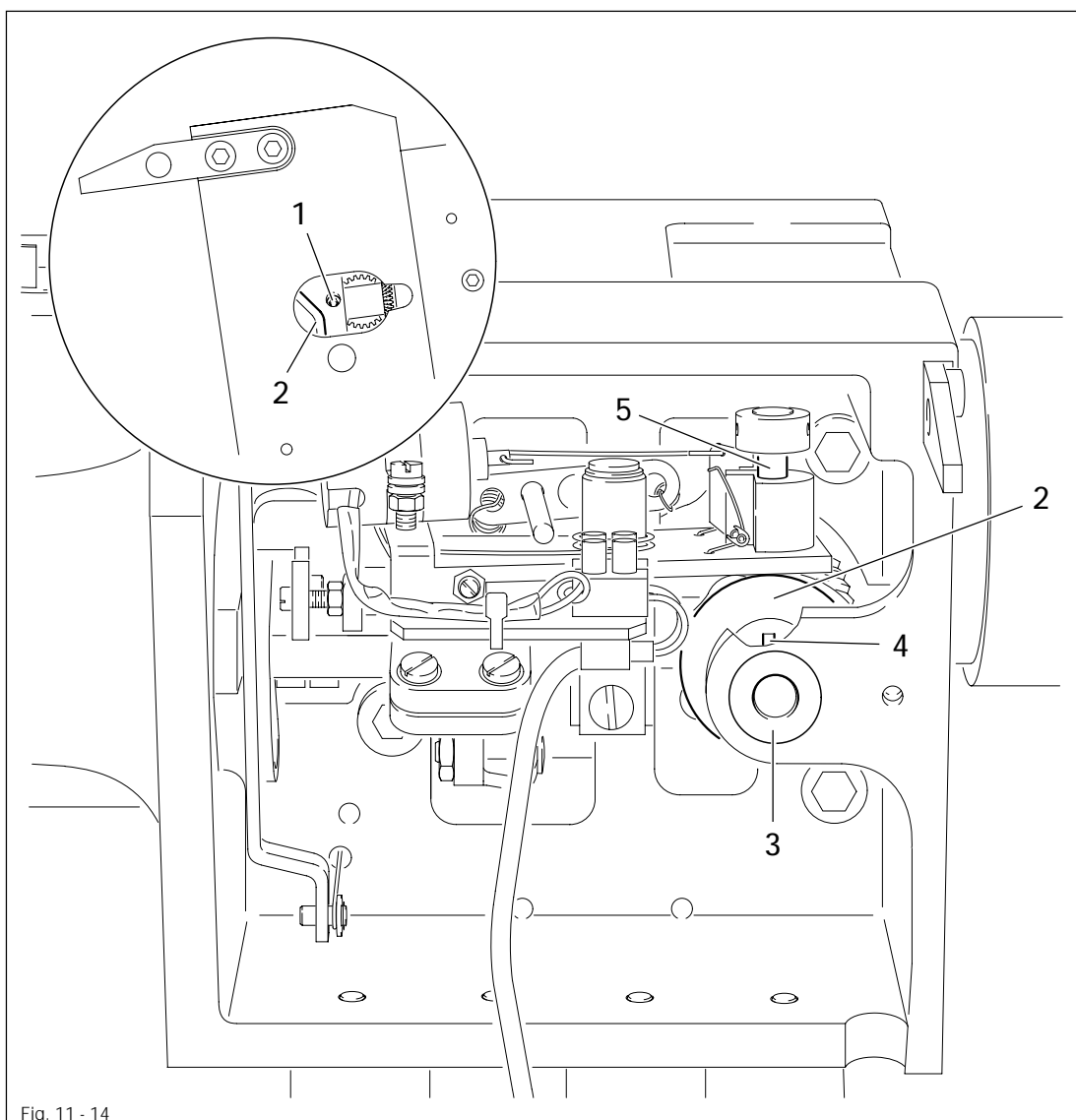

- Loosen screws 1 through the hole in the machine housing.
- Set the take-up lever at b.d.c.
- Turn control cam 2 according to **Requirement**.
- Move control cam 2 down against bearing 3 and tighten the accessible screw 1.
- Make the second screw 1 accessible and tighten it also.

Adjustment

11.05.02 Control lever height

Requirement

With the needle bar at b.d.c. there must be a clearance of **1.0 mm** between control lever 3 and control cam 4.

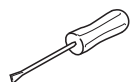
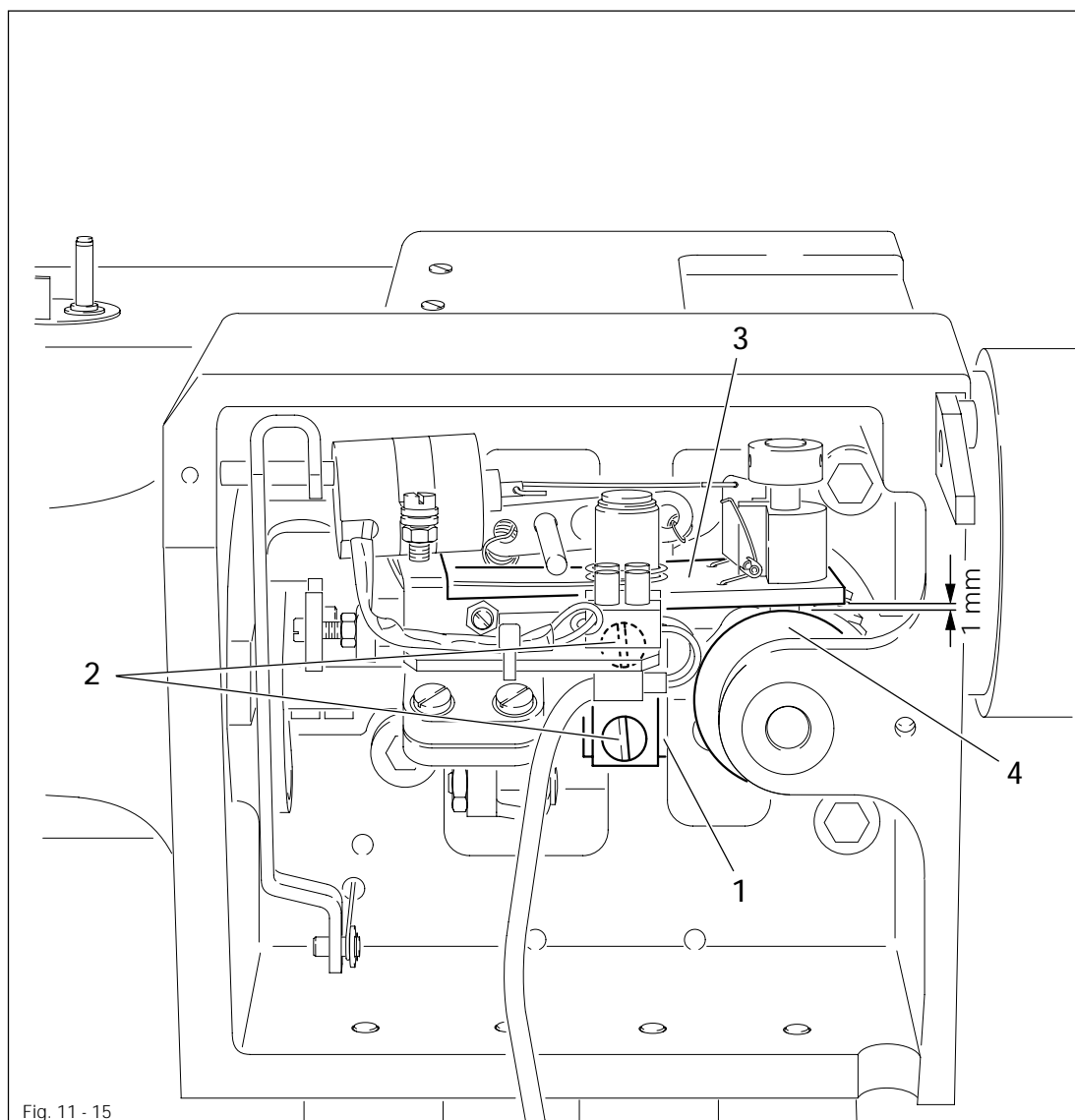

- Set the needle bar at b.d.c.
- Position bracket 1 (screws 2) of control lever 3 in the elongated hole according to Requirement.

11.05.03 Control pin

Requirement

With the needle bar at b.d.c. control pin 5 must drop easily into the track of control cam 7 when engaging solenoid 6 is operated.

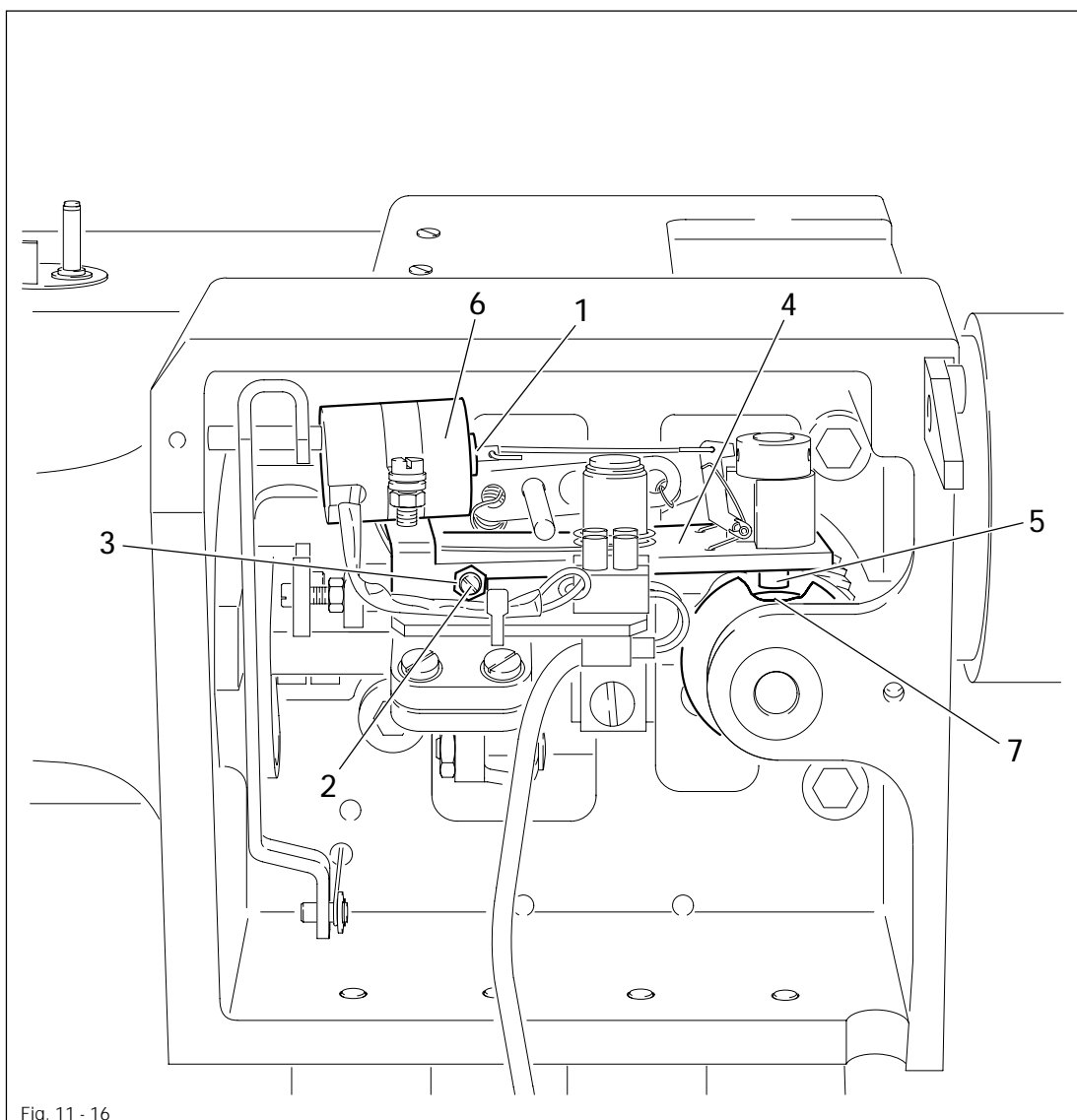
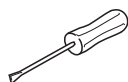

Fig. 11 - 16



- Set the needle bar at b.d.c.
- Operate the solenoid core by hand.
- Turn screw 2 (nut 3) inwards until it is resting lightly against control lever 4.
- Turn screw 2 back again by about half a turn until the movement of control pin 5 corresponds with the Requirement.

Adjustment

11.05.04 Engaging solenoid

Requirement

With the needle bar at b.d.c. and solenoid core 1 fully operated there must be a clearance of approx. 0.5 mm between locking pawl 7 and fixing collar 6.

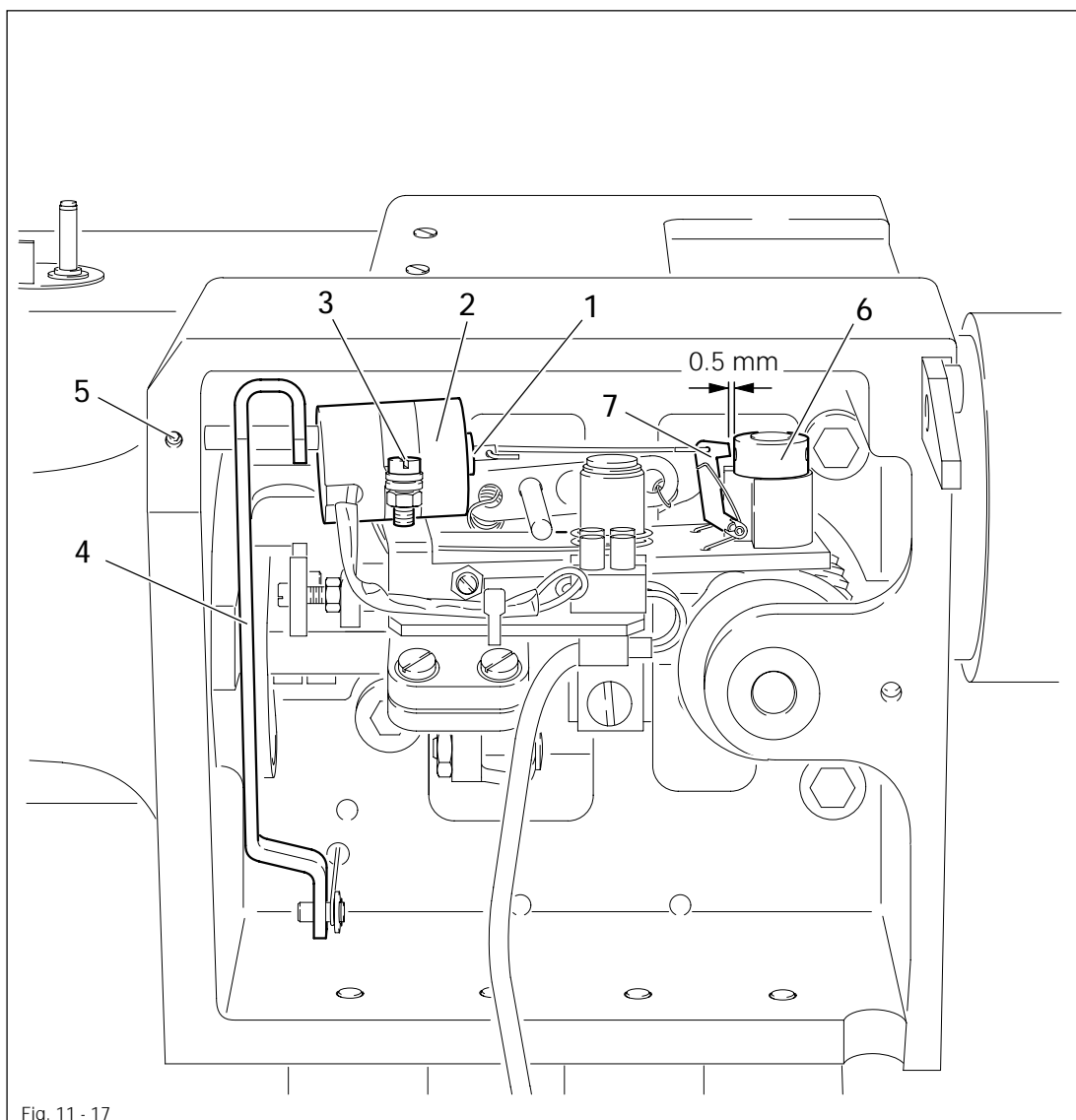
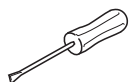

Fig. 11 - 17



- Set the needle bar at b.d.c.
- Push solenoid core 1 fully in.
- Position solenoid housing 2 (screw 3) according to Requirement



If solenoid housing 2 strikes against lever 4, position lever 4 (screw 5) a little farther to the left.

11.05.05 Control pin height

Requirement

With the thread trimmer in its resting position and locking pawl **4** engaged there must be a clearance of **0.3 mm** between the highest point of control cam **5** and control pin **6**.

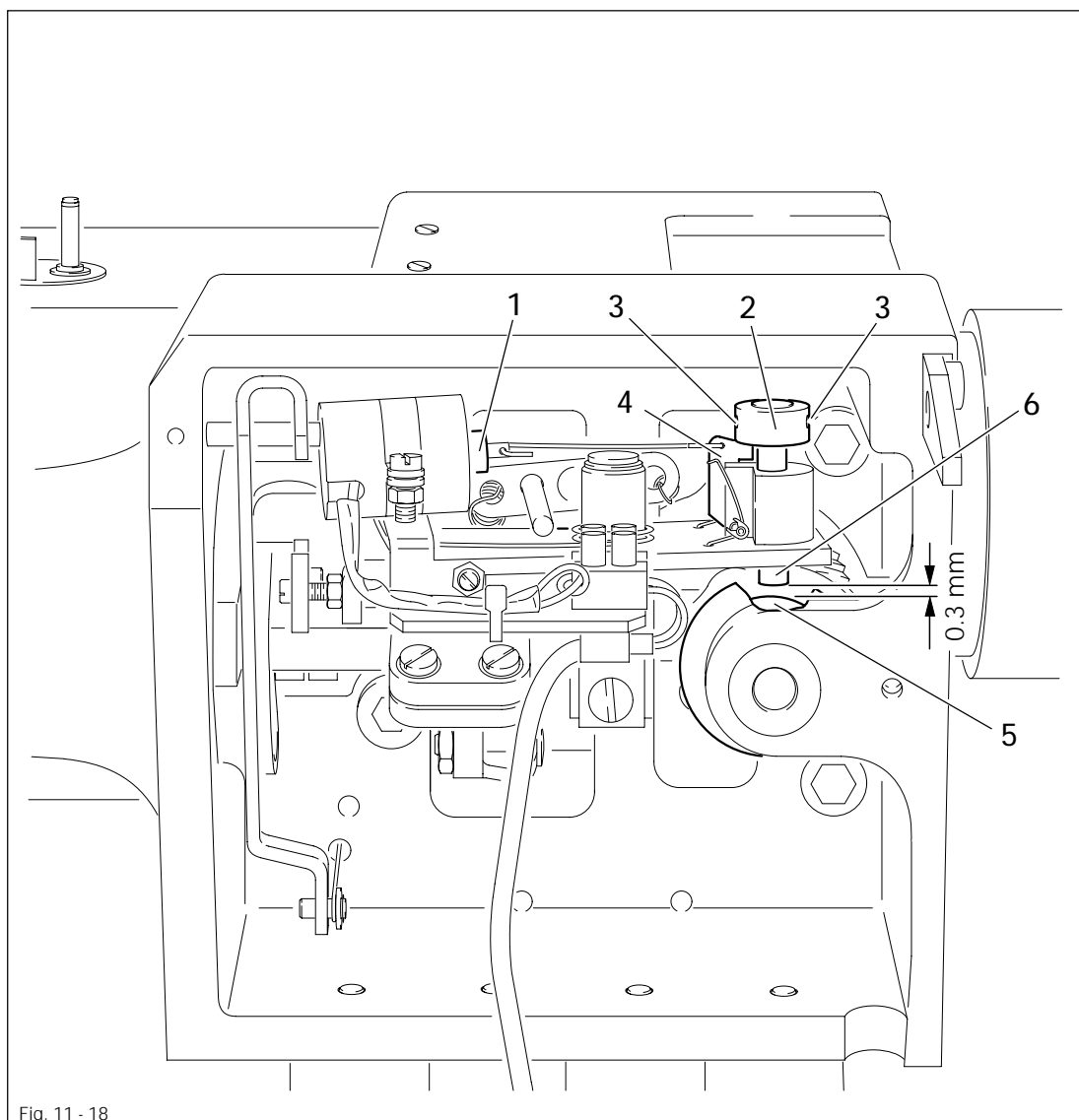

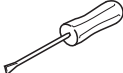
- 
- Set the needle bar at t..d.c.
 - Operate the solenoid core.
 - Position fixing collar 2 (screws 3) according to Requirement.

Adjustment

11.05.06 Front position of thread catcher

Requirement

With thread catcher 3 at its front position the back edge of the thread catcher cutout must be 1 mm beyond the front edge of bobbin case position stop 6.

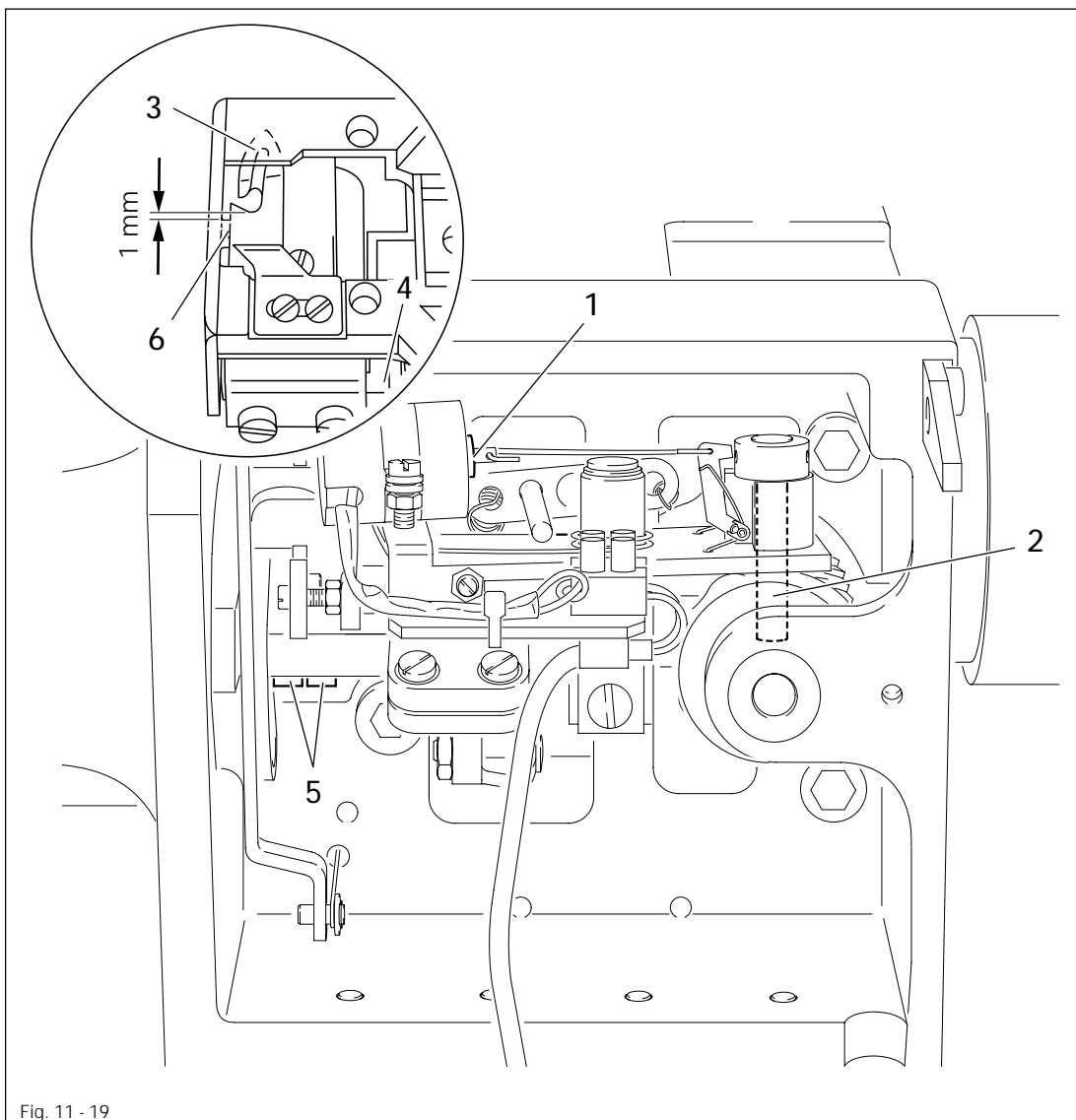
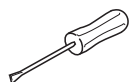

Fig. 11 - 19



- Set the needle bar at b.d.c.
- Operate solenoid core 1 so that control pin 2 drops into the cam track.
- Turn the balance wheel in sewing direction to set thread catcher 3 at its front position.
- Turn thread catcher 4 (screws 5) to set thread catcher 3 according to **Requirement**.

11.05.07 Lateral position of thread catcher

Requirement

With the needle bar at b.d.c. the point of thread catcher 4 must be at the centre of the needle.

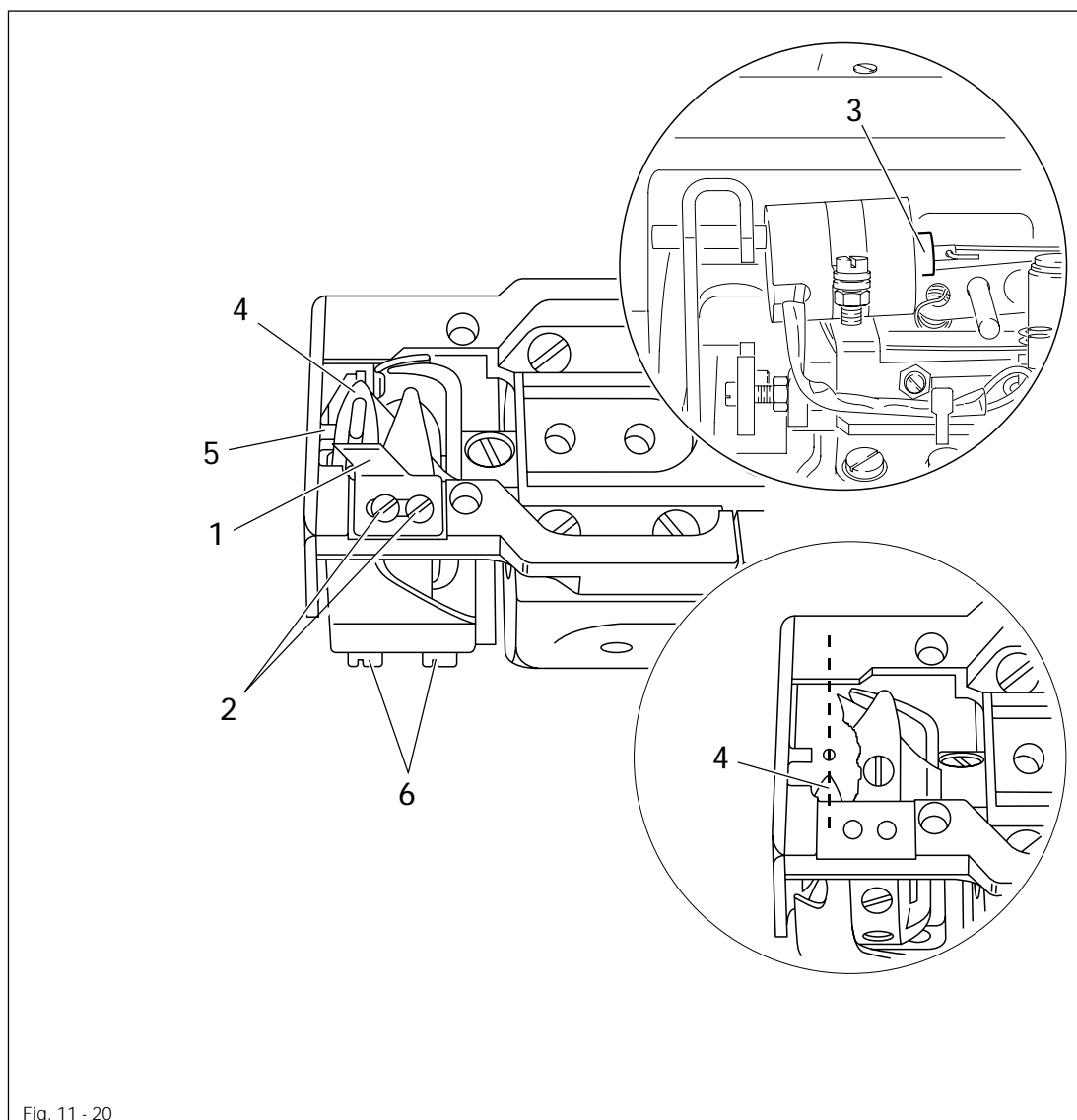
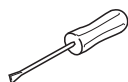

Fig. 11 - 20



- Remove knife 1 (screws 2).
- Set the needle bar at b.d.c.
- Operate solenoid core 3 by hand and turn the balance wheel until the needle bar is at t.d.c. In doing so, make sure that thread catcher 4 does not strike bobbin case position stop 5 during its motion.
- Set lateral position of thread catcher 4 (screws 6) according to **Requirement**.



For further adjustments do not yet refit knife 1.

11.05.08 Control cam (final adjustment)

Requirement

When the end of hook gib 2 is 2 mm behind the centre of bobbin-case position finger 3, as viewed in feeding direction, there must be a clearance of **approx. 4 mm** between catcher point 4 and hook gib 2.

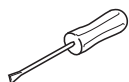
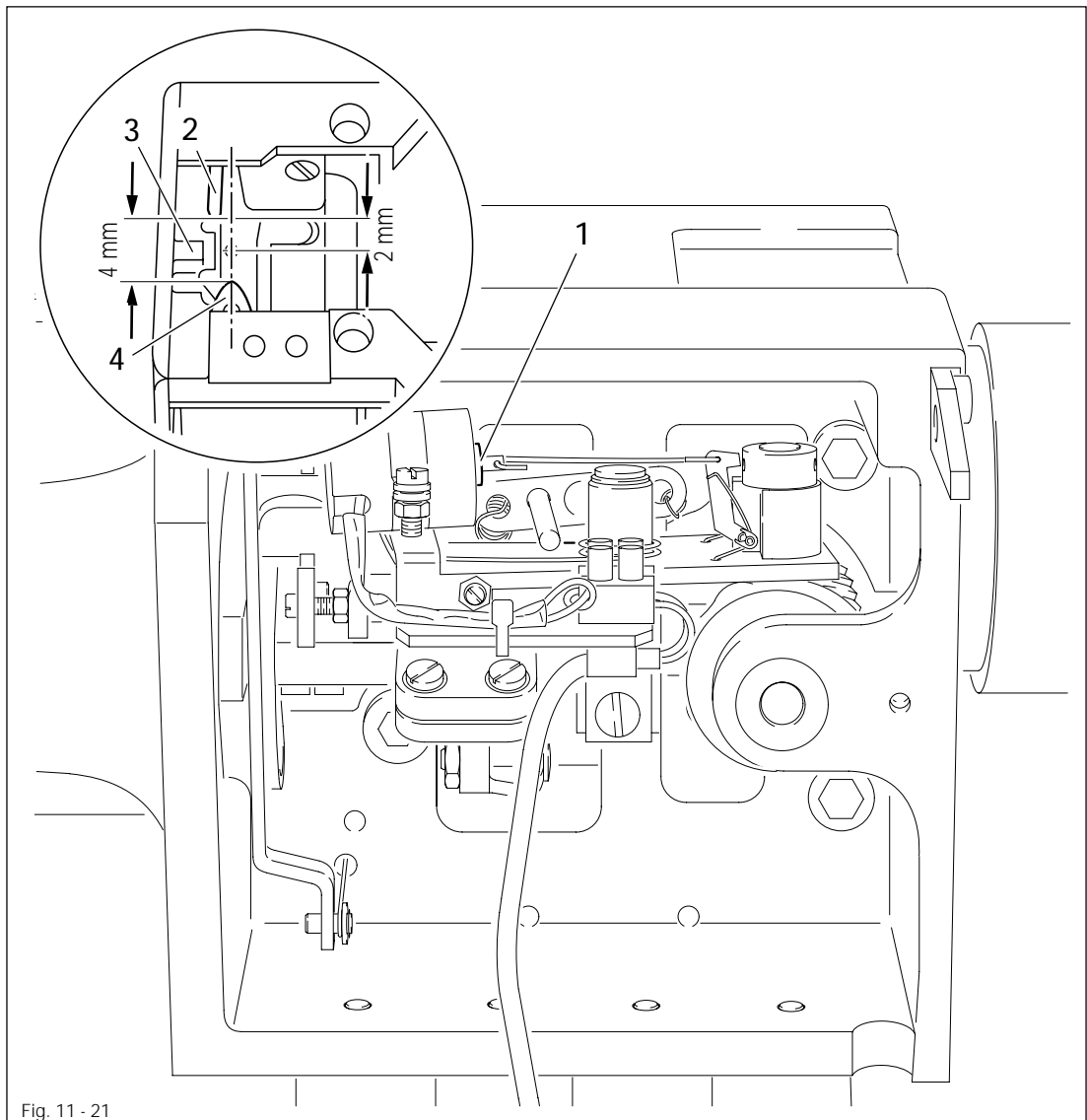

- Set the needle bar at b.d.c.
- Operate solenoid core 1 by hand.
- Turn the balance wheel farther (sewing direction) until the end of hook gib 2, viewed in sewing direction, is 2 mm behind the centre of bobbin case position finger 3.
- Check according to requirement and re-adjust control cam if necessary, see **Chapter 11.05.01 Control cam (preliminary adjustment)**.

11.05.09 Knife

Requirement

When the back edge of the thread catcher cutout is **1 mm** in front of the knife edge, the left knife edge must be flush with the edge of the thread catcher.

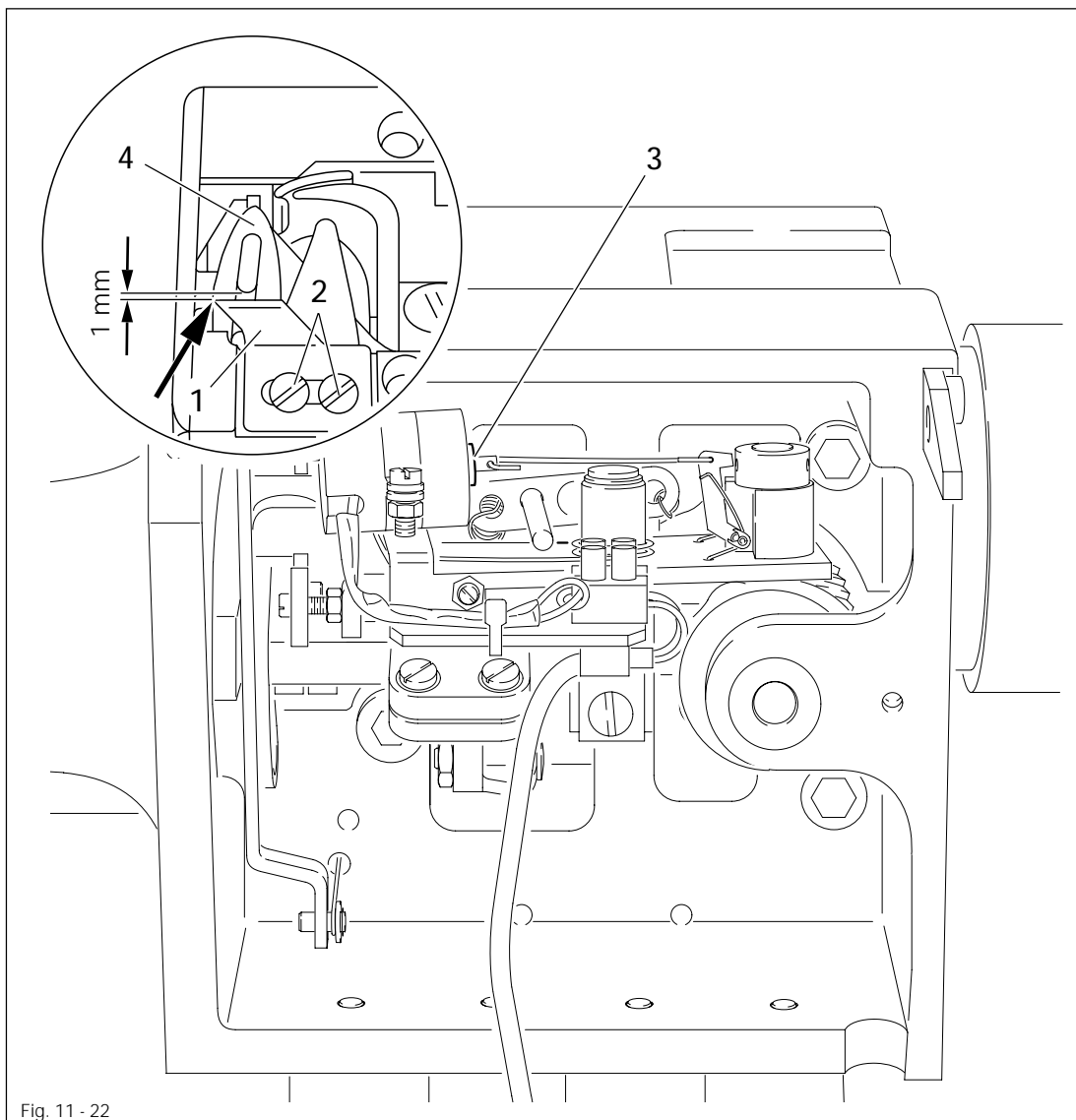
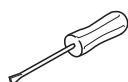

Fig. 11 - 22



- Screw on knife **1** (screws **2**) finger-tight.
- Set the needle bar at b.d.c.. and operate solenoid core **3**.
- Turn the balance wheel (sewing direction) until the short point of thread catcher **4** is aligned with the knife edge.
- Set the lateral position of knife **1** according to **Requirement** (see arrow).
- Tighten screws **2**.
- Turn the balance wheel to check whether the back of the thread catcher is not twisted in relation to the knife edge.
- If necessary re-adjust thread catcher **4**, see **Chapter 11.05.07 Lateral position of the thread catcher**.

Adjustment

11.05.10 Needle thread tension release

Requirement

When the tip of release lever 5 is at the highest point of release cam 4 the tension discs must be at least 0.5 mm apart.

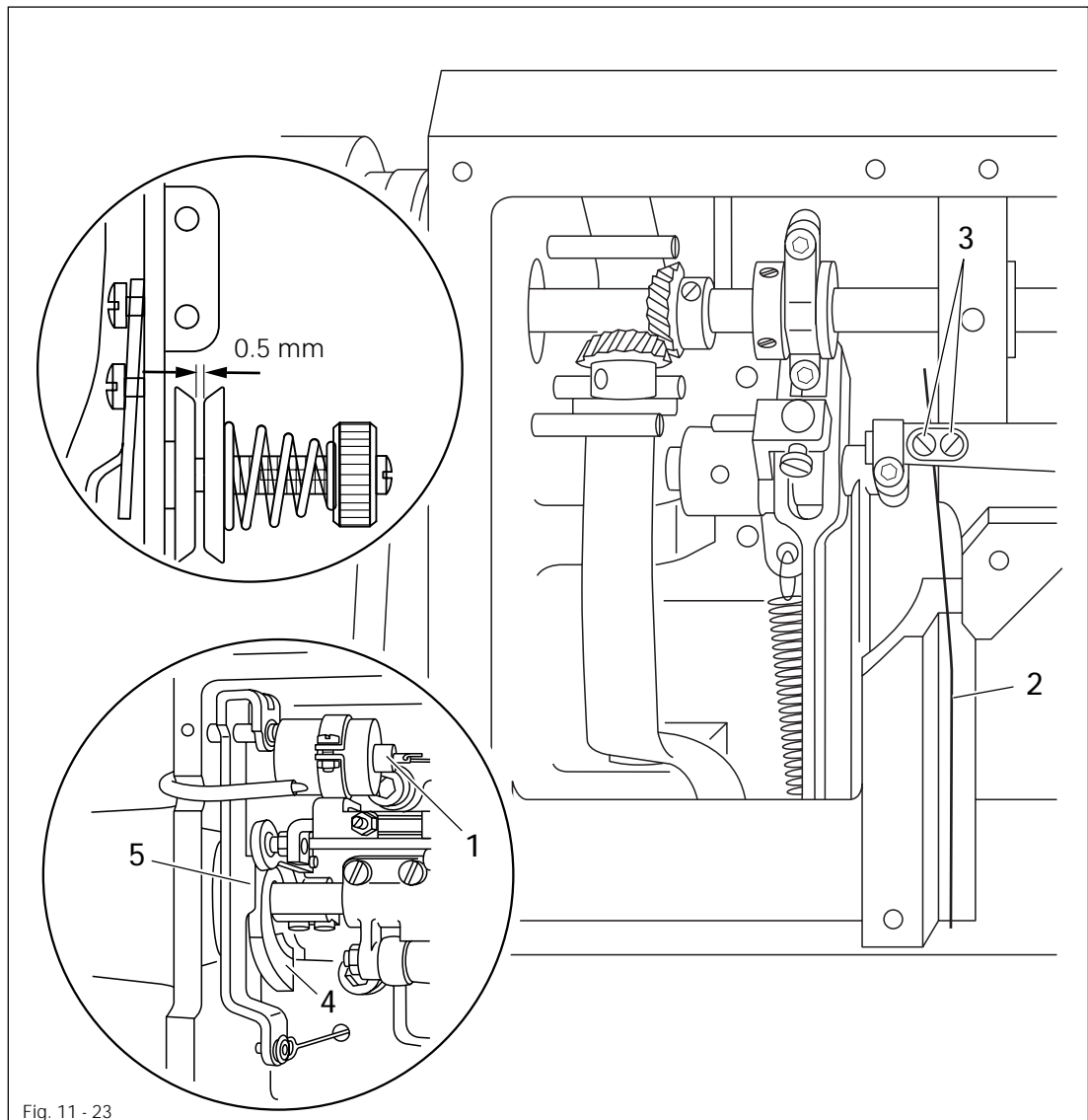
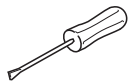

Fig. 11 - 23



- Lower the lifting presser onto the needle plate.
- Set the needle bar at b.d.c. and operate solenoid core 1.
- Turn the balance wheel (sewing direction) until the thread catcher is in its front position.
- Adjust linkage rod 2 (screws 3) according to **Requirement**.
- Turn the balance wheel to end the trimming action and set the take-up lever at t.d.c.
- Check that the thread tension is fully active.
- Finally, lightly grease the surfaces of release cam 4 and the tip of release lever 5.

11.05.11 Cutting test

Requirement

The knife must stand parallel to the thread catcher and both threads must be reliably cut.

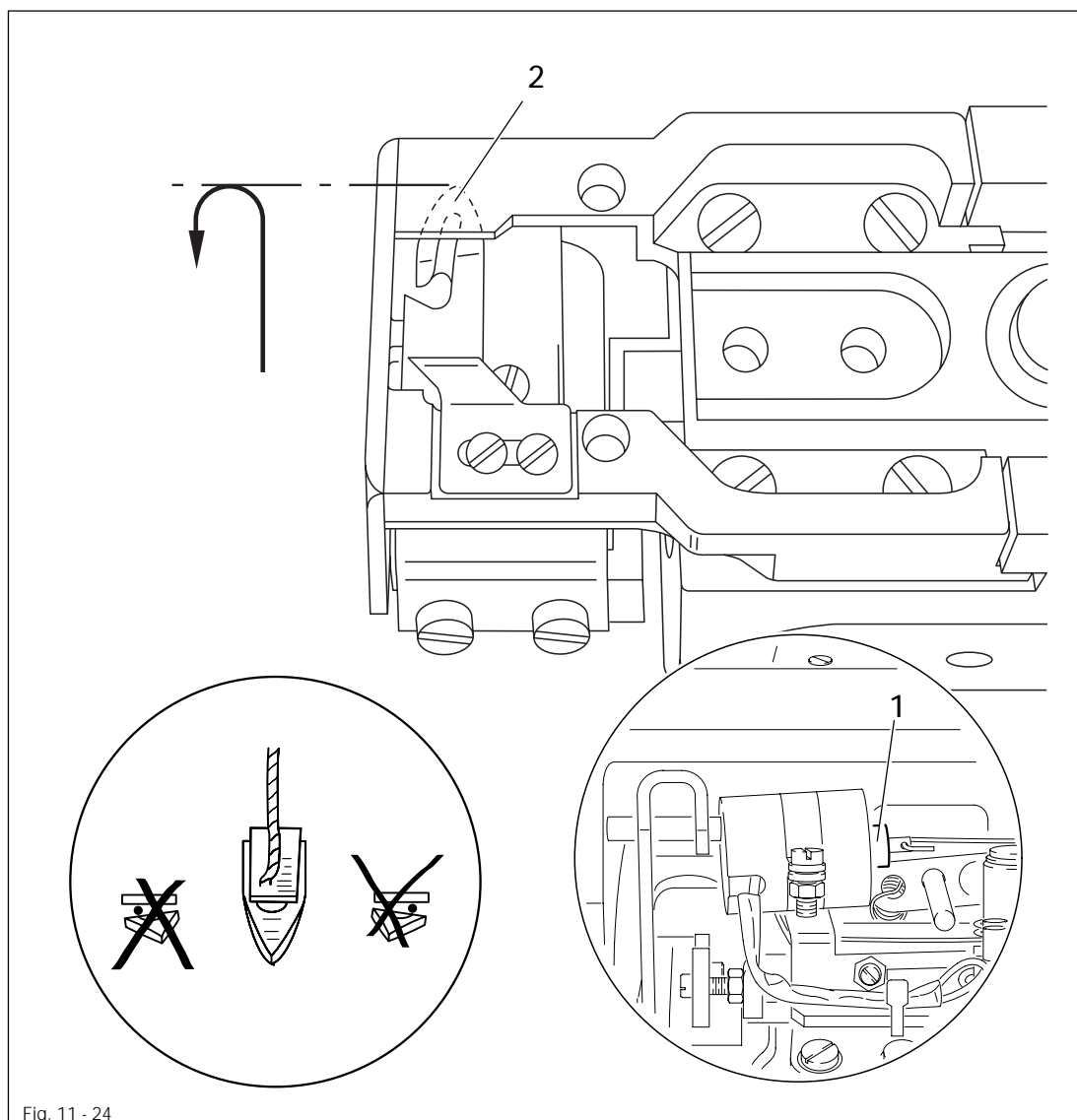
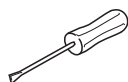

Fig. 11 - 24



- Set the needle bar at b.d.c. and operate solenoid core 1.
- Turn balance wheel (sewing direction) until thread catcher 2 is in its front position.
- Take a double piece of thread, pull it into the cutout of thread catcher 2 and turn the balance wheel farther to make a cutting test.
- Check that both threads are reliably cut.
- If necessary, re-adjust thread catcher 2, see Chapter 11.05.07 Lateral position of the thread catcher.

11.05.12 Adjusting the synchronizer

Requirement

1. On a seam interruption the machine must position **4 mm** past b.d.c.
2. After a thread trim the machine must position at t.d.c. of the take-up lever.

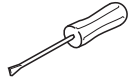

- Carry out adjustment according to motor instruction manual.

PFAFF

**G.M. PFAFF KAISERSLAUTERN
INDUSTRIEMASCHINEN AG**

Postfach 3020
D-67653 Kaiserslautern

Königstr. 154
D-67655 Kaiserslautern

Telefon: (0631) 200-0
Telefax: (0631) 17202
E-Mail: info@pfaff-industrial.com

Gedruckt in der BRD
Printed in Germany
Imprimé en R.F.A.
Impreso en la R.F.A.