

# PFAFF

## 1181

## 1183

Instruction Manual

## 1181-D

## 1183-D

This instruction manual applies to machines from the following serial numbers onwards:

# 6 001 000 →



This Instruction Manual is valid for all models and subclasses listed in the chapter " **Specifications** ".



The adjustment manual for the machines can be downloaded free of charge from the internet address

**[www.pfaff-industrial.com/de/service/download/index.php3](http://www.pfaff-industrial.com/de/service/download/index.php3)**.

As an alternative to the internet download the adjustment manual can also be ordered in book form under part no. 296-12-18 710/002.

The reprinting, copying or translation of PFAFF Instruction Manuals, whether in whole or in part, is only permitted with our previous authorization and with written reference to the source.

## **PFAFF Industrie Maschinen AG**

Postfach 3020

D-67653 Kaiserslautern

Königstr. 154

D-67655 Kaiserslautern

Contents .....		Chapter - Page
<b>1</b>	<b>Safety .....</b>	<b>1 - 1</b>
1.01	Directives .....	1 - 1
1.02	General notes on safety .....	1 - 1
1.03	Safety symbols .....	1 - 2
1.04	Important points for the user .....	1 - 2
1.05	Operating and specialist personnel .....	1 - 3
1.05.01	Operating personnel .....	1 - 3
1.05.02	Specialist personnel .....	1 - 3
1.06	Danger .....	1 - 4
<b>2</b>	<b>Proper use .....</b>	<b>2 - 1</b>
<b>3</b>	<b>Specifications .....</b>	<b>3 - 1</b>
3.01	PFAFF 1181, PFAFF 1183 .....	3 - 1
3.02	Models and subclasses .....	3 - 2
<b>4</b>	<b>Disposal of the machine .....</b>	<b>4 - 1</b>
<b>5</b>	<b>Transport, packaging and storage .....</b>	<b>5 - 1</b>
5.01	Transport to the customer .....	5 - 1
5.02	Transport within the customer's premises .....	5 - 1
5.03	Disposal of the packaging .....	5 - 1
5.04	Storage .....	5 - 1
<b>6</b>	<b>Explanation of the symbols .....</b>	<b>6 - 1</b>
<b>7</b>	<b>Controls .....</b>	<b>7 - 1</b>
7.01	On/off switch .....	7 - 1
7.02	Keys on the machine head .....	7 - 1
7.03	Pedal .....	7 - 2
7.04	Lever for lifting the presser foot .....	7 - 2
7.05	Feed regulator disk / Reverse feed lever .....	7 - 3
7.06	Knee lever .....	7 - 3
7.07	Thread trimmer -731/01 .....	7 - 4
7.08	Switch for thread wiper -909/04 .....	7 - 4
7.09	Control panel .....	7 - 5
7.09.01	Screen displays .....	7 - 5
7.09.02	Function keys .....	7 - 5
<b>8</b>	<b>Mounting and commissioning the machine .....</b>	<b>8 - 1</b>
8.01	Mounting .....	8 - 1
8.01.01	Adjusting the table-top height .....	8 - 1
8.01.02	Adjusting the V-belt tension .....	8 - 2
8.01.03	Mounting the upper V-belt guard .....	8 - 2
8.01.04	Mounting the lower V-belt guard .....	8 - 3
8.01.05	Mounting the spool holder .....	8 - 3
8.02	Connecting the plug-in connections and earth cables .....	8 - 4

	Contents .....	Chapter - Page
8.03	Start inhibitor .....	8 - 5
8.03.01	Mounting the start inhibitor .....	8 - 5
8.03.02	Checking the start inhibitor function .....	8 - 5
8.04	Basic setting of the machine drive unit .....	8 - 6
8.05	Commissioning the machine .....	8 - 7
8.06	Switching the machine on/off .....	8 - 7
8.07	Table top cutout. ....	8 - 8
8.08	Mounting the table top .....	8 - 9
<b>9</b>	<b>Preparation .....</b>	<b>9 - 1</b>
9.01	Inserting the needle .....	9 - 1
9.02	Winding the bobbin thread, adjusting the thread tension .....	9 - 2
9.03	Removing/Inserting the bobbin case .....	9 - 3
9.04	Inserting the bobbin case / Adjusting the bobbin thread tension .....	9 - 3
9.05	Threading the needle thread / Adjusting the needle thread tension .....	9 - 4
9.06	Entering the start and end backtacks .....	9 - 5
<b>10</b>	<b>Sewing .....</b>	<b>10 - 1</b>
10.01	Darning program .....	10 - 2
10.02	Counted seam .....	10 - 2
10.03	Error messages .....	10 - 3
10.04	Explanation of the error signals .....	10 - 4
10.05	Parameter settings .....	10 - 5
10.05.01	Selecting the user level .....	10 - 5
10.05.02	Example of a parameter input .....	10 - 6
10.05.03	Liste der Parameter .....	10 - 7
<b>11</b>	<b>Care and maintenance .....</b>	<b>11 - 1</b>
11.01	Cleaning the machine .....	11 - 1
11.02	Topping up the oil tank .....	11 - 2
<b>12</b>	<b>Wearing parts .....</b>	<b>12 - 1</b>

## 1 Safety

### 1.01 Directives

This machine is constructed in accordance with the European regulations contained in the conformity and manufacturer's declarations.

In addition to this Instruction Manual, also observe all generally accepted, statutory and other regulations and legal requirements and all valid environmental protection regulations!

The regionally valid regulations of the social insurance society for occupational accidents or other supervisory organizations are to be strictly adhered to!

### 1.02 General notes on safety

- This machine may only be operated by adequately trained operators and only after having completely read and understood the Instruction Manual!
- All Notes on Safety and Instruction Manuals of the motor manufacturer are to be read before operating the machine!
- The danger and safety instructions on the machine itself are to be followed!
- This machine may only be used for the purpose for which it is intended and may not be operated without its safety devices. All safety regulations relevant to its operation are to be adhered to.
- When exchanging sewing tools (e.g. needle, roller presser, needle plate and bobbin), when threading the machine, when leaving the machine unattended and during maintenance work, the machine is to be separated from the power supply by switching off the On/Off switch or by removing the plug from the mains!
- Everyday maintenance work is only to be carried out by appropriately trained personnel!
- Repairs and special maintenance work may only be carried out by qualified service staff or appropriately trained personnel!
- Work on electrical equipment may only be carried out by appropriately trained personnel!
- Work is not permitted on parts and equipment which are connected to the power supply! The only exceptions to this rule are found in the regulations EN 50110.
- Modifications and alterations to the machine may only be carried out under observance of all the relevant safety regulations!
- Only spare parts which have been approved by us are to be used for repairs! We expressly point out that any replacement parts or accessories which are not supplied by us have not been tested and approved by us. The installation and/or use of any such products can lead to negative changes in the structural characteristics of the machine. We are not liable for any damage which may be caused by non-original parts.

## 1.03

### Safety symbols



Danger!  
Points to be observed.



Danger of injury for operating and specialist personnel!



### Caution

Do not operate without finger guard and safety devices.  
Before threading, changing bobbin and needle, cleaning etc. switch off main switch.

## 1.04

### Important points for the user

- This Instruction Manual is an integral part of the machine and must be available to the operating personnel at all times.
- The Instruction Manual must be read before operating the machine for the first time.
- The operating and specialist personnel is to be instructed as to the safety equipment of the machine and regarding safe work methods.
- It is the duty of the user to only operate the machine in perfect running order.
- It is the obligation of the user to ensure that none of the safety mechanisms are removed or deactivated.
- It is the obligation of the user to ensure that only authorized persons operate and work on the machine.

Further information can be obtained from your PFAFF agent.

## 1.05 Operating and specialist personnel

### 1.05.01 Operating personnel

Operating personnel are persons responsible for the equipping, operating and cleaning of the machine as well as for taking care of problems arising in the sewing area.

The operating personnel is required to observe the following points and must:

- always observe the Notes on Safety in the Instruction Manual!
- never use any working methods which could adversely affect the safety of the machine!
- not wear loose-fitting clothing or jewelery such as chains or rings!
- also ensure that only authorized persons have access to the potentially dangerous area around the machine!
- always immediately report to the person responsible any changes in the machine which may limit its safety!

### 1.05.02 Specialist personnel

Specialist personnel are persons with a specialist education in the fields of electrics, electronics and mechanics. They are responsible for the lubrication, maintenance, repair and adjustment of the machine.

The specialist personnel is obliged to observe the following points and must:

- always observe the Notes on Safety in the Instruction Manual!
- switch off the On/Off switch before carrying out adjustments or repairs, and ensure that it cannot be switched on again unintentionally!
- wait until the luminous diode on the control box is no longer blinking or on before beginning adjustment or repair work.
- never work on parts which are still connected to the power supply! Exceptions are explained in the regulations EN 50110.
- replace the protective coverings and close the electrical control box after all repairs or maintenance work!

1.06

## Danger



A working area of **1 meter** is to be kept free both in front of and behind the machine while it is in operation so that it is always easily accessible.



Never reach into the sewing area while sewing! Danger of injury by the needle!



Never leave objects on the table while adjusting the machine settings! Objects can become trapped or be slung away! Danger of injury!

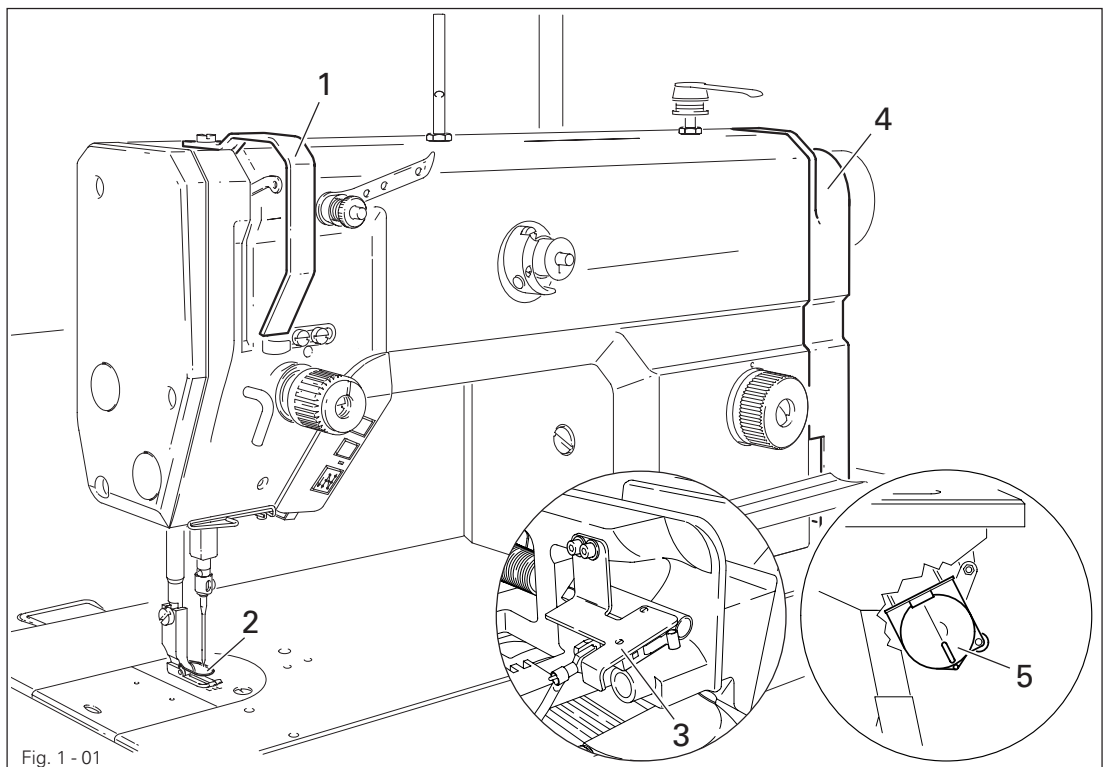

Fig. 1 - 01



Do not operate the machine without its take-up lever guard **1!**  
Danger of injury due to the motion of the take-up lever!



Do not operate the machine without the finger guard **2!**  
Danger of injury by the needle!



Do not operate machines with integrated motor without start inhibitor **3!**  
Danger of injury if the machine is started accidentally!



If an external motor is used, do not operate the machine without the belt guards **4 and 5!**  
Danger of injury by the drive belt!



2

**Proper use**

The PFAFF 1181 is an single-needle ultra-high-speed seamer with compound feed

The PFAFF 1183 is an single-needle ultra-high-speed seamer with drop feed

The PFAFF 1181-D is an oil-free single-needle high-speed seamer with compound feed

The PFAFF 1183-D is an oil-free single-needle high-speed seamer with drop feed

These machines are used in the industry for sewing lockstitch seams.



Any and all uses of this machine which have not been approved of by the manufacturer are considered to be inappropriate! The manufacturer cannot be held liable for any damage caused by the inappropriate use of the machine! The appropriate use of the machine includes the observance of all operational, adjustment, maintenance and repair measures required by the manufacturer!

## 3 Specifications ▲

### 3.01 PFAFF 1181, PFAFF 1181-D, PFAFF 1183, PFAFF 1183-D

Stitch type: ..... 301 (lockstitch)

Needle system: ..... 134 or 134 KK on subclass -731/01

Needle size in 1/100 mm:

Version A: ..... 60 - 70

Version B: ..... 80 - 100

Version CN: ..... 110 - 120

Effective balance wheel diameter: ..... 65 mm

Fabric clearance: ..... 9 – 13 mm

Clear workspace width: ..... 260 mm

Clear workspace height: ..... 125 mm

Bed-plate dimensions: ..... 476 x 177 mm

Sewing head dimensions:

Length: ..... approx. 550 mm

Width: ..... approx. 180 mm

Height (above table): ..... approx. 300 mm

Max. stitch length:

Version A: ..... 3,0 mm

Version B: ..... 4.5 mm

Version CN: ..... 6.0 mm

Max. speed PFAFF 1181/ 1183

Version A and B: ..... 5500 spm ♦

Subclass -731/01: ..... 4500 spm ♦

Subclass -948/51: ..... 5000 spm ♦

Subclass -8/44: ..... 3000 spm

Version CN: ..... 3000 spm

Max. speed PFAFF 1181-D / 1183-D

Version A and B: ..... 4000 spm ♦

Subclass -8/44: ..... 3000 spm

Needle bar stroke: ..... 30 or 36 mm

Power connection:

Operating voltage: ..... 190 – 240 V 50/60 Hz, single-phase

Max. input: ..... 400 VA

Fuse: ..... 1 x 16 A, inert

Noise data:

Emission sound level at the workplace at appropriate speed

(Noise measurement in accordance with DIN 45 635-48-A-1, ISO 11204, ISO 3744, ISO 4871)

PFAFF 1181-D at = 3200 spm: .....  $L_{pA} < 76,0$  dB(A) ■

PFAFF 1183-D at = 3200 spm: .....  $L_{pA} < 76,5$  dB(A) ■

PFAFF 1181 at 4400 spm: .....  $L_{pA} < 80,0$  dB(A) ■

PFAFF 1183 at 4400 spm: .....  $L_{pA} < 80,5$  dB(A) ■

Net weight of sewing head: ..... approx. 30 kg

Gross weight of sewing head: ..... approx. 38 kg

▲ Subject to technical alterations

◆ 3,800 s.p.m. with 36 mm needle bar stroke

■  $K_{pA} = 2,5$  dB

## 3.02 Versions and subclasses

Version A: ..... for sewing light materials

Version B: ..... for sewing medium materials

Version CN: ..... for sewing medium-heavy materials

**Work aids:**

Subclass -731/01 ..... edge trimmer

Subclass -900/24 ..... thread trimmer

Subclass -909/04 ..... thread wiper

Subclass -910/06 ..... automatic foot lift

Subclass -911/37 ..... automatic back-tacking mechanism

### 4 Disposal of machine

- The proper disposal of the machine is the responsibility of the customer.
- The materials used in the machines are steel, aluminium, brass and various plastics. The electrical equipment consists of plastics and copper.
- The machine is to be disposed of in accordance with the locally valid environmental protection regulations. If necessary, a specialist is to be commissioned.



Special care is to be taken that parts soiled with lubricants are separately disposed of in accordance with the locally valid pollution control regulations!

### **5 Transport, packaging and storage**

#### **5.01 Transport to the customer's premises**

The machines are delivered completely packed.

#### **5.02 Transport within the customer's premises**

The manufacturer bears no liability for transport within the customer's premises or to the individual locations of use. Make sure that the machines are always transported upright.

#### **5.03 Disposal of the packaging**

The packaging of these machines consists of paper, cardboard and VCE fiber. The proper disposal of the packaging is the responsibility of the customer.

#### **5.04 Storage**

The machine can be stored for up to 6 months if not in use. During this time it should be protected from dust and moisture.

For longer storage the individual parts of the machine, especially the moving parts, must be protected from corrosion, e.g. by a film of oil.

---

## Explanation of the symbols

---

### 6 Explanation of the symbols

In the following section of this Instruction Manual, certain tasks or important pieces of information are accentuated by symbols.

The symbols used have the following meanings:



Note, information



Cleaning, care



Lubrication, greasing

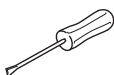

Servicing, repairing, adjustment, maintenance  
(only to be carried out by specialist personnel)

7 Controls

7.01 On/off switch

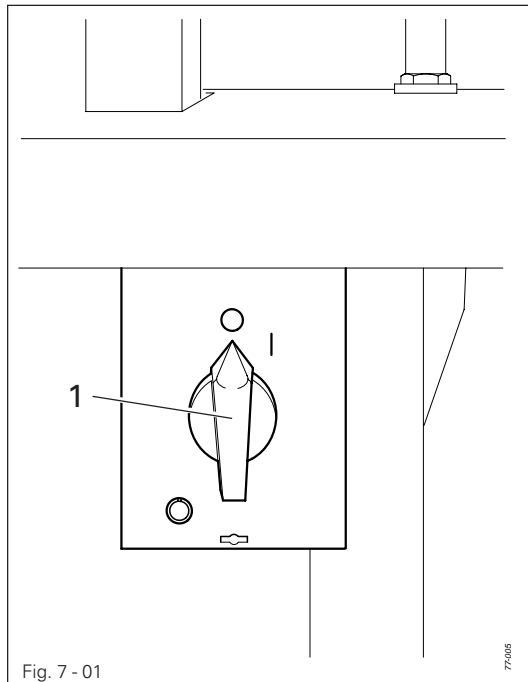

Fig. 7 - 01

777005

- Switch the machine on or off by turning main switch 1.

7.02 Keys on the machine head

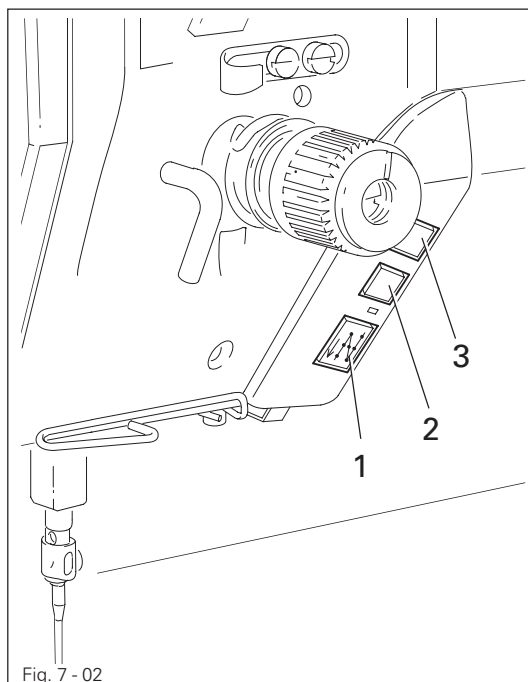
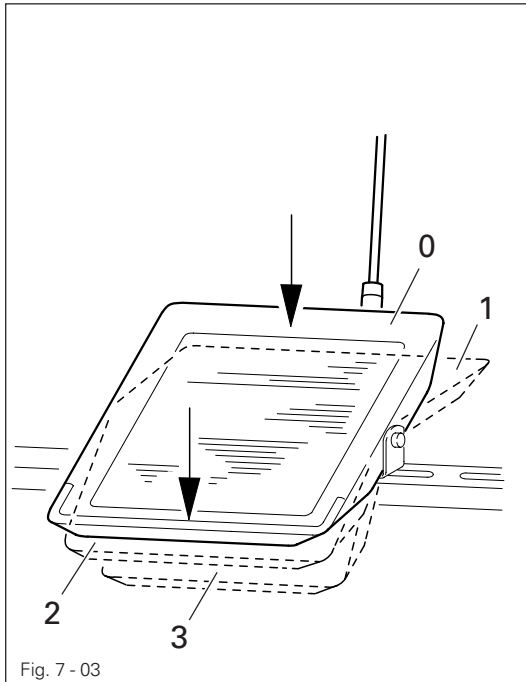

Fig. 7 - 02

- The following functions are triggered by pressing the respective key.
  - Key 1: reverse sewing
  - Key 2: prevention or release of the automatic start back tack or finish back tack.
  - Key 3: when sewing is interrupted, the needle can either be raised or lowered as required.

## 7.03 Pedal



- 0 = Machine stop
- 1 = Sew
- 2 = Raise presser foot (for machines with -910/06)
- 3 = Trim thread (for machines with -900/24)

## 7.04 Lever for lifting the presser foot

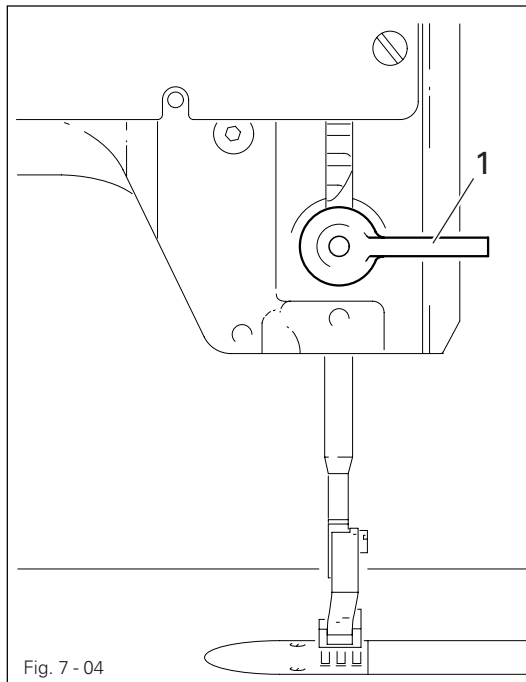

- The presser foot is raised by turning lever 1.



7.05 Feed regulator disk / Reverse feed lever

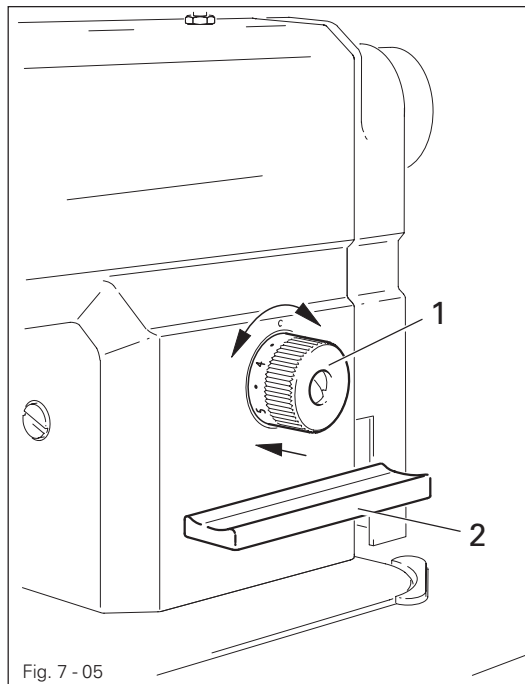

- The stitch length can be set by simultaneously applying pressure to disk 1 and turning it to the desired setting.
- For reverse sewing press lever 2.

7.06 Knee lever

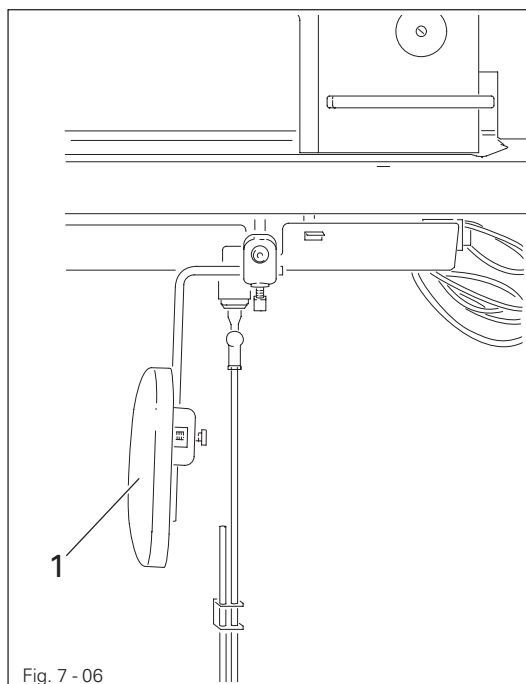

- By pressing the knee lever 1 in the direction of the arrow, the presser foot is raised.

7.07

## Thread trimmer -731/01

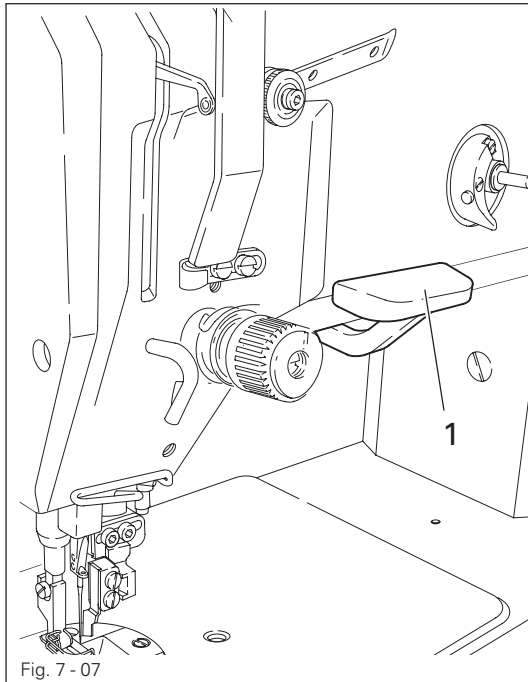

Do not touch the running motor! Danger of injury!

- By pressing or raising key 1, the edge trimmer is switched on or off.

7.08

## Switch for thread wiper -909/04

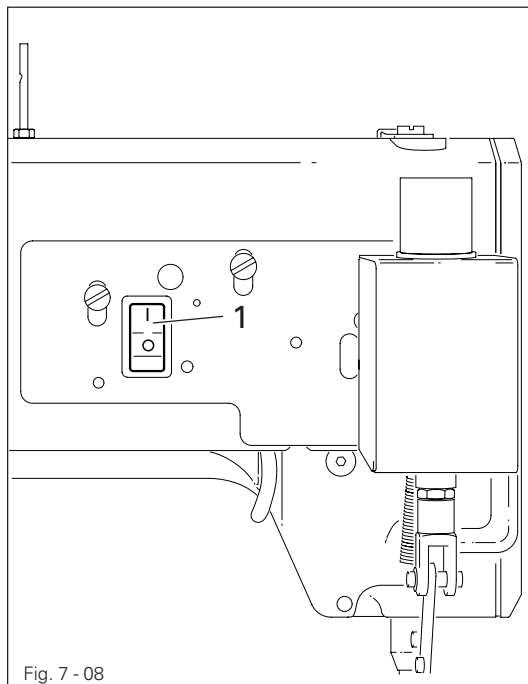

- By moving switch 1, the thread wiper can be switched on or off.

Position I : aggregate is on

Position 0 : aggregate is off

7.09 Control panel

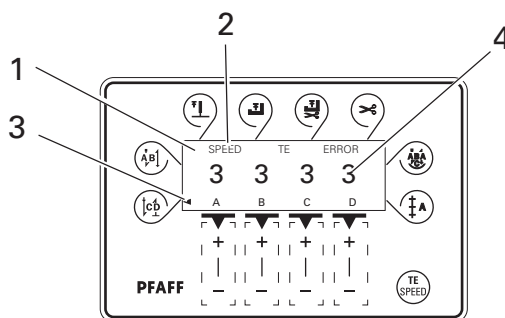

The control panel consists of display 1 and the function keys described below. The display 1 consists of a single-line alpha-numerical, 7 segment LCD display with 8 symbols. The texts 2, located above and next to the LCD display, show the respective status of the function keys and the operating status of the machine. The control panels switches on all LCD-segments and the horn automatically for a short time during the power-on phase, after which the lettering PFAFF appears on the display, until the higher-ranking control unit sends commands to the control panel.

The function keys are located around the display 1. They are foil-packed without permanent marking and without contact signal. Fixed functions are allocated to the keys, see **Chapter 7.09.02 Function keys**.

7.09.01 Screen displays

- Activated functions are displayed with a triangular marking 3 below or next to the respective function key.
- In the sewing mode all relevant sewing data is displayed and can be changed directly, depending on the status of the machine, see also **Chapter 10 Sewing**.
- During the parameter input the selected parameter number with the corresponding value is displayed, see **Chapter 10.05.02 Example of a parameter input**.

7.09.02 Function keys

The function keys described below are used basically to switch machine functions on and off.

Each time a key is pressed, this must be confirmed by at least one beep tone. Irrespective of the machine mode a double beep signal is given if invalid keys are pressed or maximum values reached.

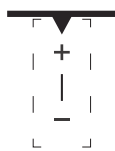

If a corresponding value has to be set for the activated function, this is carried out with the corresponding +/- key. By pressing and holding the corresponding +/- key, the relevant numerical value 4 is changed slowly to begin with. If the corresponding +/- key is held down longer, the values change more quickly.



## Start backtacks

- If this key is pressed, the backtacks at the beginning of the seam (start backtacks) are switched on or off. The number of forward stitches (A) or reverse stitches (B) for the start backtacks can be changed by pressing the +/- key underneath. To convert from double backtack to single backtack set the number of stitches for the corresponding seam section at zero.



## End backtacks

- If this key is pressed, the backtacks at the end of the seam (end backtacks) are switched on or off. The number of reverse stitches (C) or forward stitches (D) can be changed by pressing the +/- key underneath. To convert from double backtack to single backtack set the number of stitches for the corresponding seam section at zero.



## Needle position

- If this key is pressed the „needle raised after sewing stop“ function is switched on or off. When the function is switched on, the needle positions at t.d.c. after sewing stops.



## Foot position after stop

- If this key is pressed the „foot raised after sewing stop“ function is switched on or off. When the function is switched on, the presser foot is raised after sewing stops.



## Foot position after trimming

- If this key is pressed the „foot raised after thread trimming“ function is switched on or off. When the function is switched on, the presser foot is raised after thread trimming.



## Thread trimmer

- If this key is pressed the thread trimming function is switched on or off.



## Darning program

- If this key is pressed the darning program function is switched on or off. The counted seam function is switched off automatically.



## Counted seam

- If this key is pressed the counted seam function is switched on or off. The darning program function is switched off automatically.



## TE/Speed

- If this key is pressed once the speed limit for the sewing mode is activated.
- If this key is pressed twice (within 5 seconds) the machine changes from sewing to input mode.

## 8 Mounting and commissioning the machine



The machine must only be mounted and commissioned by qualified personnel!  
All relevant safety regulations are to be observed!



If the machine is delivered without a table, be sure that the frame and the table top which you intend to use can hold the weight of the machine and the motor. It must be ensured that the supporting structure is sufficiently sturdy, even during sewing operations.

### 8.01 Mounting

The necessary electricity supply must be available at the machine's location. Also, a stable and horizontal surface as well as adequate lighting are required at the location.



Depending on the type of table, the method of packaging used may require that the table top be lowered for transport. The following is a description of how to adjust the height of the table top.

#### 8.01.01 Adjusting the table-top height

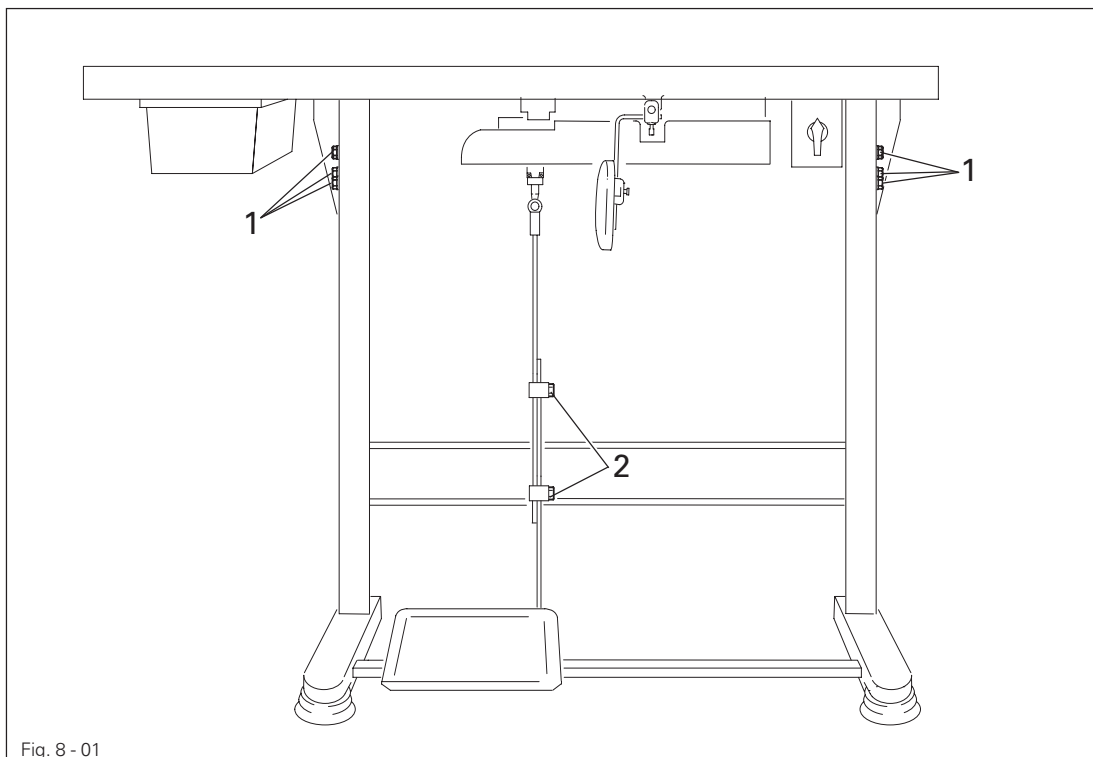

Fig. 8 - 01

- Loosen screws 1 and 2 and set the desired table-top height
- Tighten screws 1 well.
- Adjust the pedal to the desired position and tighten screw 2.

# Mounting and commissioning the machine

## 8.01.02 Adjusting the V-belt tension



This step is eliminated for integrated sewing motors.

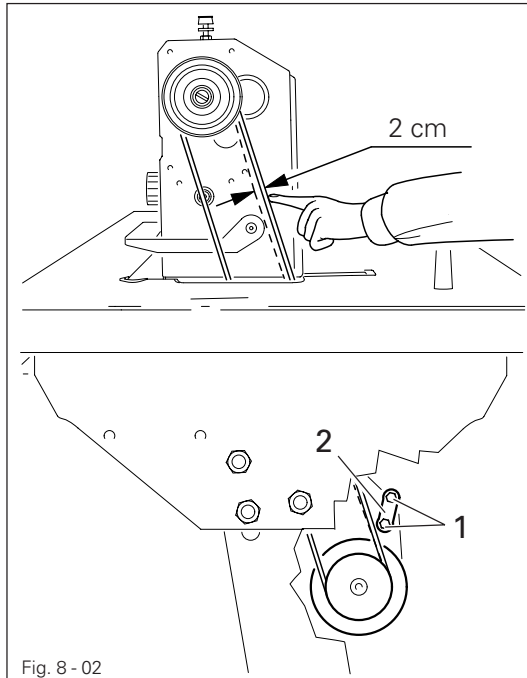

Fig. 8 - 02

- Loosen nuts 1.
- Tighten the V-belt with belt take-up hanger 2.
- Tighten nuts 1.



A quick motor is shown in **Fig. 8-02**. If another motor is used, carry out this step according to the instructions in the motor instruction manual.

## 8.01.03 Mounting the upper V-belt guard



This step is eliminated for integrated sewing motors.

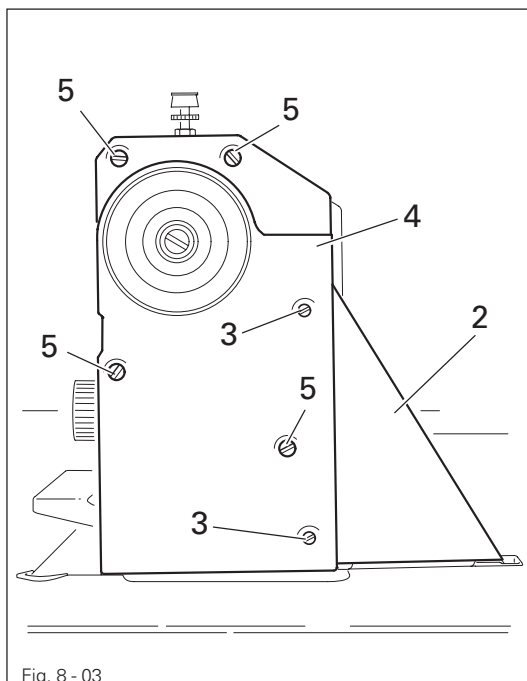
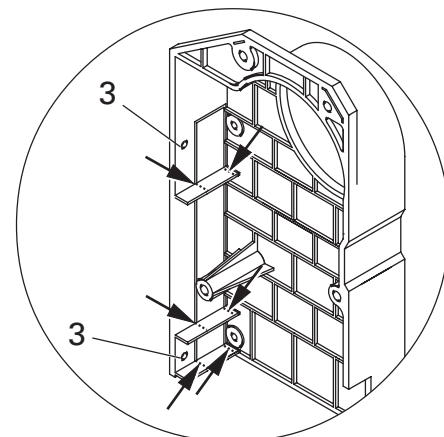

Fig. 8 - 03

- Break out the belt guard case 1 at the points marked by the arrows.
- Fasten belt guard 2 in holes 3.
- Attach belt guard 4 to the machine case with screws 5.



## 8.01.04 Mounting the lower V-belt guard



This step is eliminated for integrated sewing motors.

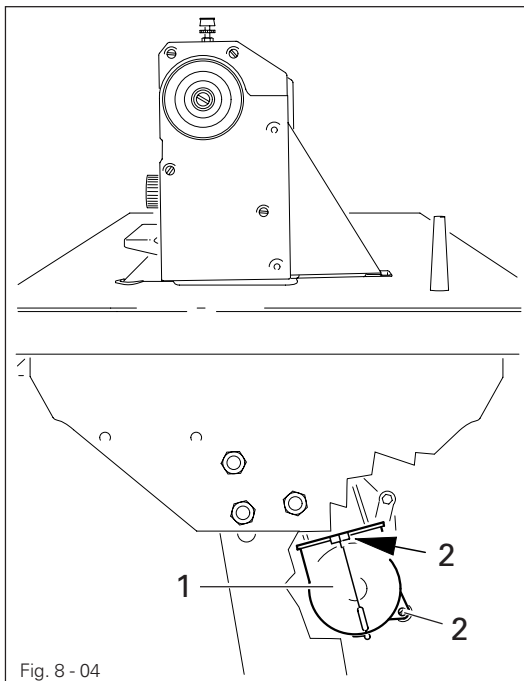

Fig. 8 - 04

- Align belt-guard 1 in such a way that both the motor pulley and the V-belt run freely.
- Tighten screws 2.



A quick motor is shown in Fig. 8-04. If another motor is used, carry out this step according to the instructions in the motor instruction manual.

## 8.01.05 Mounting the spool holder

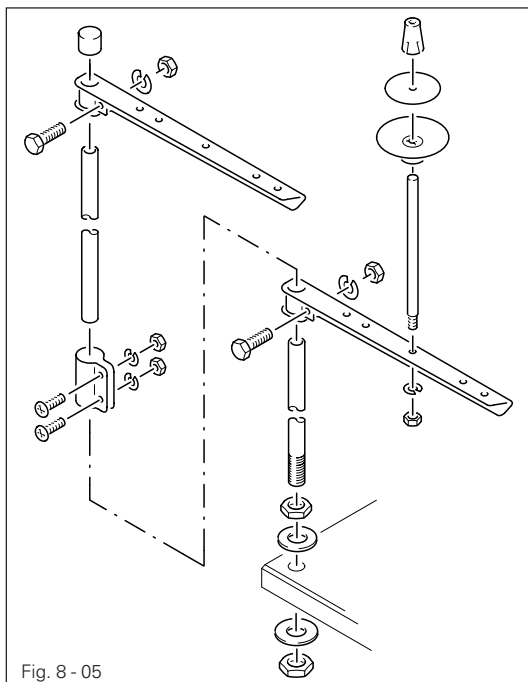
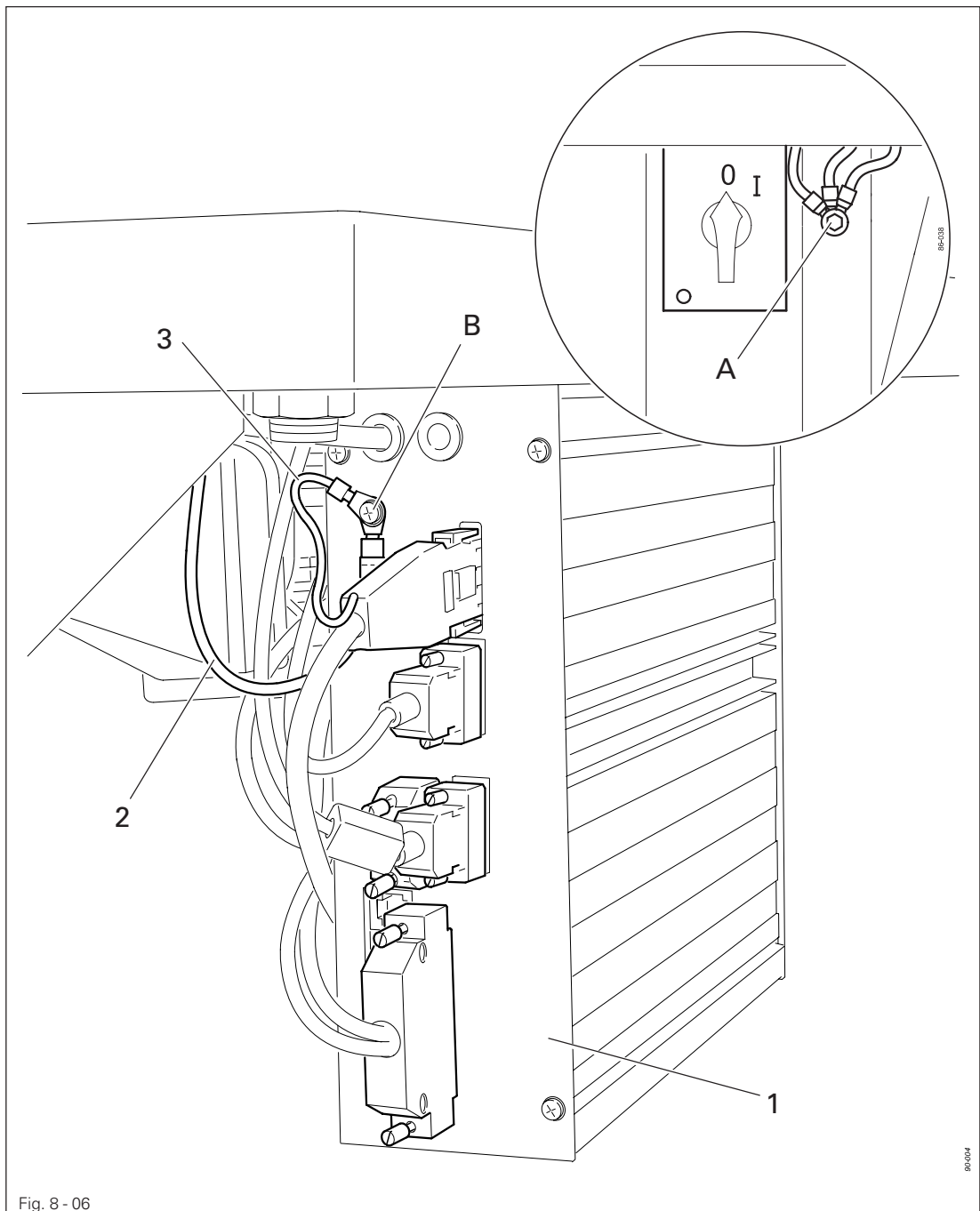

Fig. 8 - 05

- Mount the spool holder as shown in Fig. 8-05.
- Insert the spool holder into the hole in the table top and fasten it with the nuts enclosed.



- Connect all plugs as labelled to the control box 1.
- Screw the earth cable from the sewing head and the main switch to earth point A.
- Connect earth point A to earth point B with earth cable 2.
- Screw the earth cable 3 from the motor to earth point B.



## 8.03 Start inhibitor

### 8.03.01 Mounting the start inhibitor

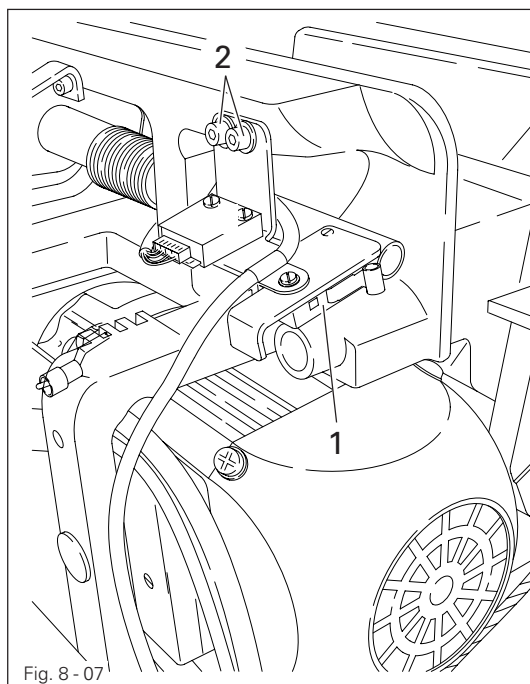

- Set the machine into the table top.
- After loosening screws 2, set switch 1 so that it is activated when the sewing head is in an upright position.
- In this position tighten screws 2.

### 8.03.02 Checking the start inhibitor function

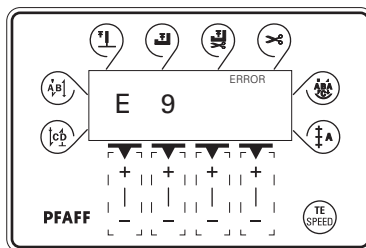

- Switch the machine on at the main switch and tilt back the sewing head. The error message "E9" must appear on the control panel.
- If the message does not appear, check the setting of safety switch 1.
- Set the sewing head upright and acknowledge the error message by pressing the  TE/Speed key. The machine is ready for operation again.

# Mounting and commissioning the machine

## 8.04 Basic setting of the machine drive unit

- Switch on the machine.
- Press TE/Speed key twice to call up the input mode.

2 x 

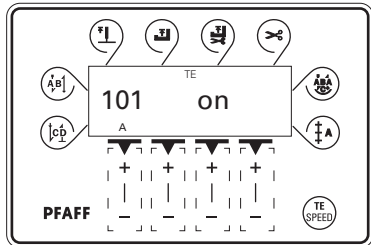

- By pressing the corresponding +/- key, call up parameter "798" and select service level "C", see Chapter 10.05.01 Selecting the user level

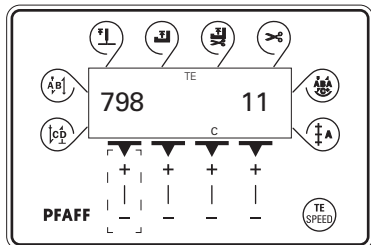

- By pressing the corresponding +/- key, call up parameter "800" (rotation direction of the motor).
- By pressing the corresponding +/- key enter the value "0".

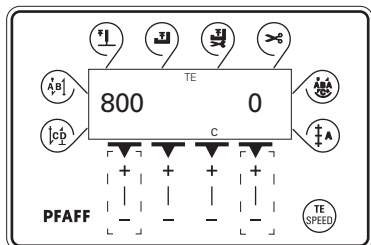

- By pressing the corresponding +/- key select parameter "700".

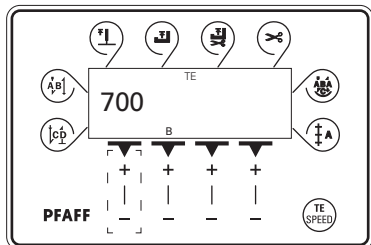

- Sew one stitch by operating the pedal.
- Turn the balance wheel in the direction of sewing until the tip of the needle is level with the top edge of the needle plate.



- Conclude the adjustment of the sewing motor by pressing the TE/Speed key.

### 8.05 Commissioning the machine

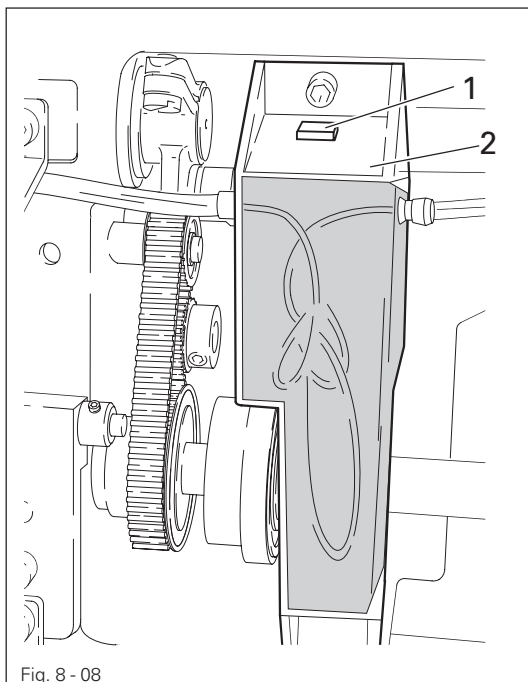

- Check the machine, especially the electrical leads, for any damage.
- Clean the machine thoroughly (see **chapter 10 Care and maintenance**).
- Have specialists ensure that the machine's motor can be operated with the available electricity supply and that it is connected properly. If not, the machine must not be operated.
- Before commissioning the machine, remove grommet 1 of oil container 2.



Grommet 1 is only needed for support during transportation and must not be used while the machine is in operation.

### 8.06 Switching the machine on/off

- Switch the machine on (see Chapter 7.01 On/Off switch).

# Mounting and commissioning the machine

## 8.07 Table top cutout.

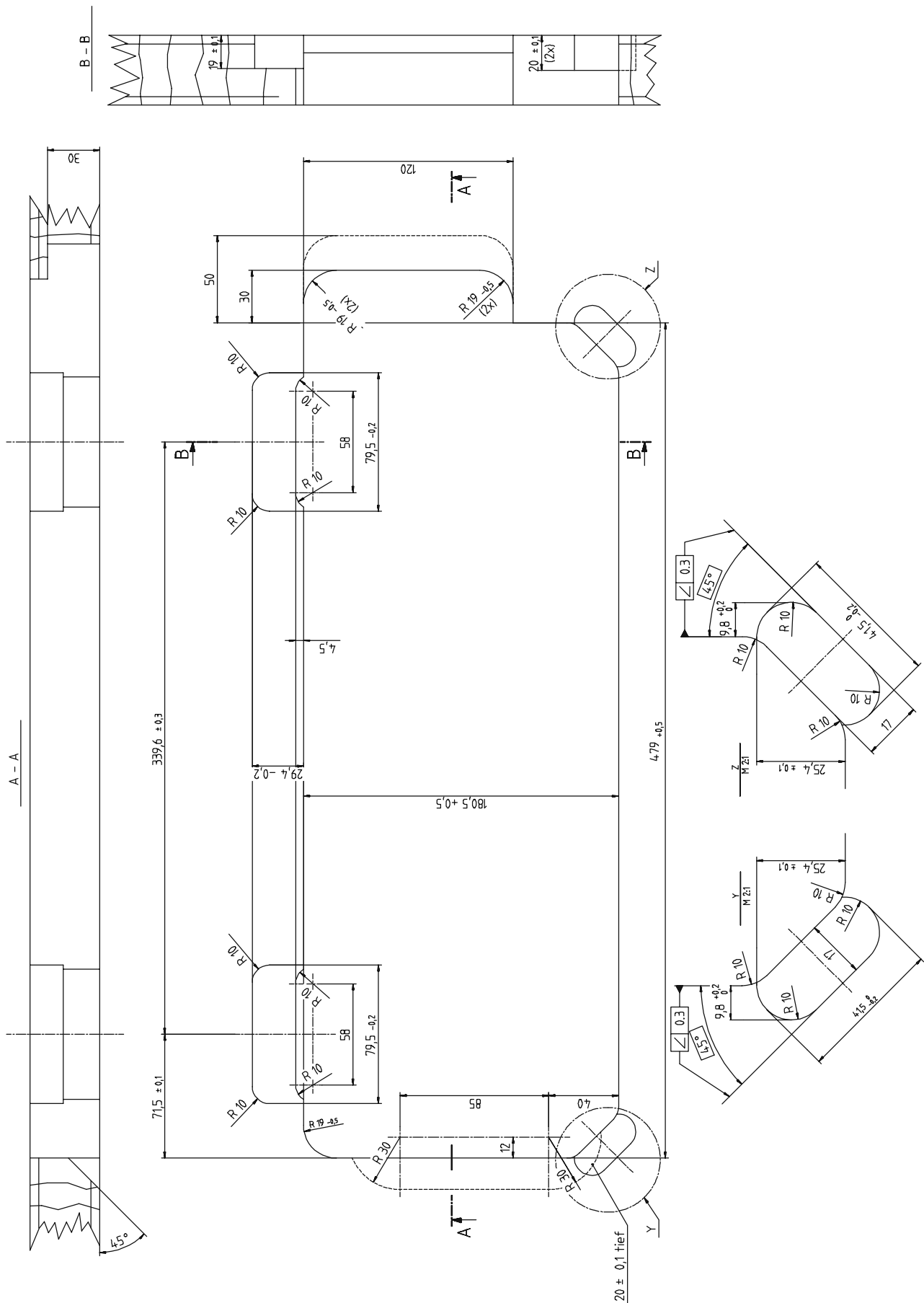

## 8.08

### Mounting the table top

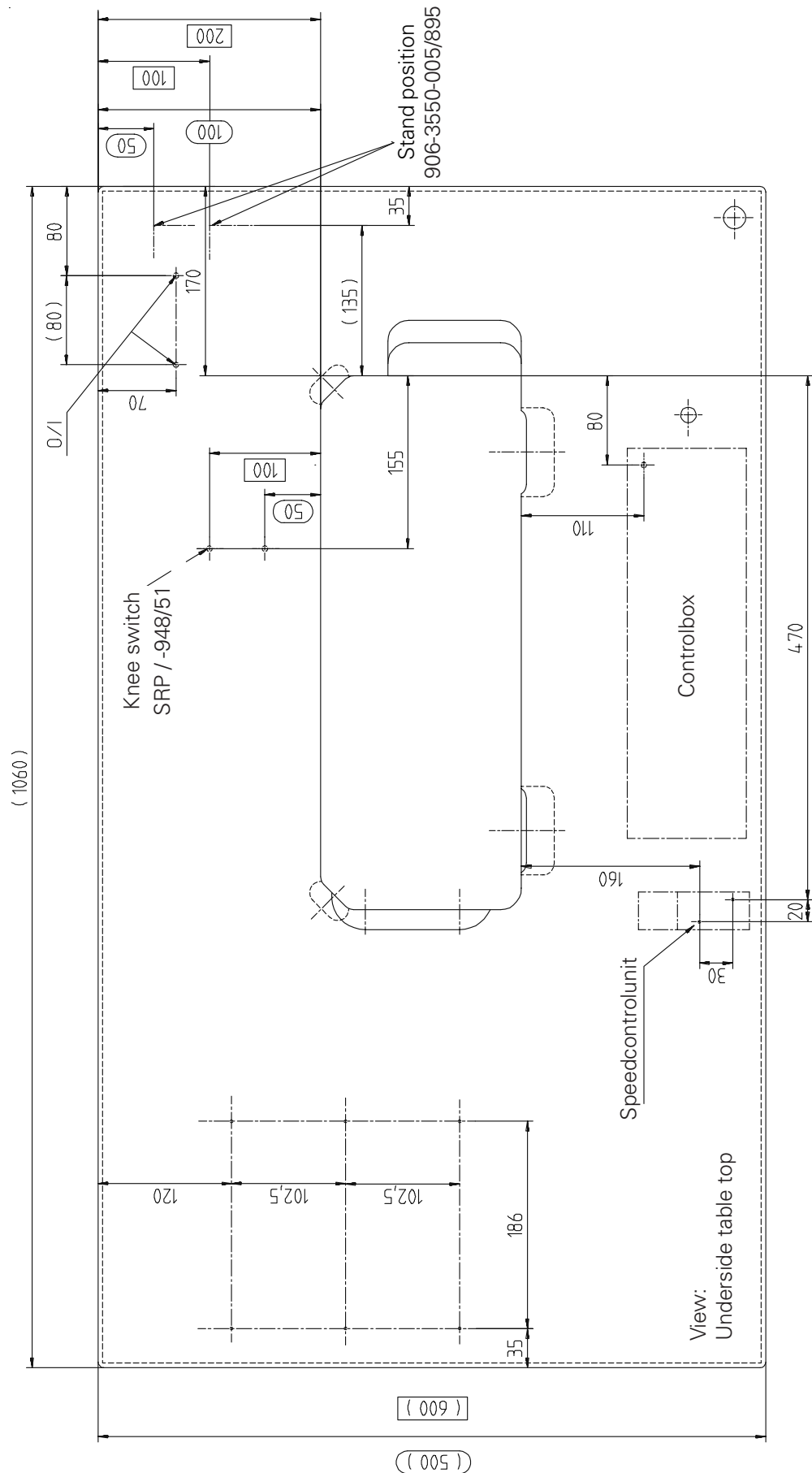

91-264 343-95  
Vers. 08.12.04

9

## Preparation



All regulations and instructions in this Instruction Manual are to be observed!  
Special attention is to be paid to the safety regulations!



All preparation work is only to be carried out by appropriately trained personnel.  
Before all preparation work, the machine is to be separated from the electricity supply by removing the plug from the mains or switching off the On/Off switch!

9.01

## Inserting the needle

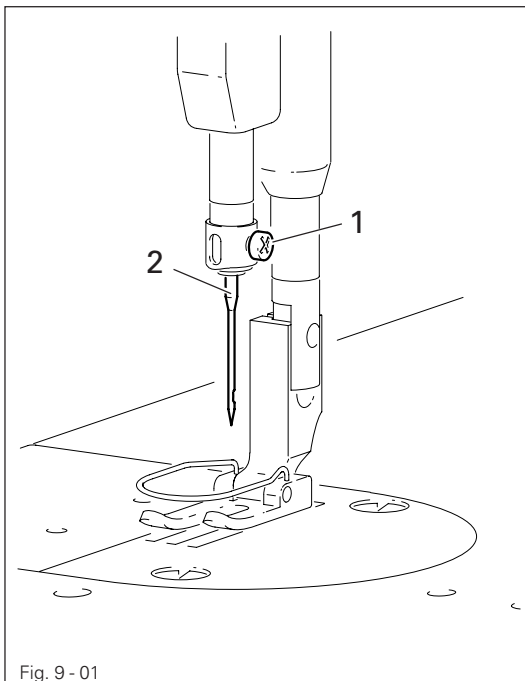

Fig. 9-01



Switch off the machine!  
Danger of injury due to unintentional starting of the machine!



Only use needles from the system intended for the machine, see **Chapter 3 Specifications**.

- Raise needle bar.
- Loosen screw 1 and insert needle 3 until you feel it stop.
- The long needle groove must be aligned in the direction of the machine head.
- Tighten screw 1.



The selection of the correct needle depends on the model of the machine and the material and threads being sewn (see **chapter 3 Specifications**).

## 9.02

## Winding the bobbin thread, adjusting the thread tension

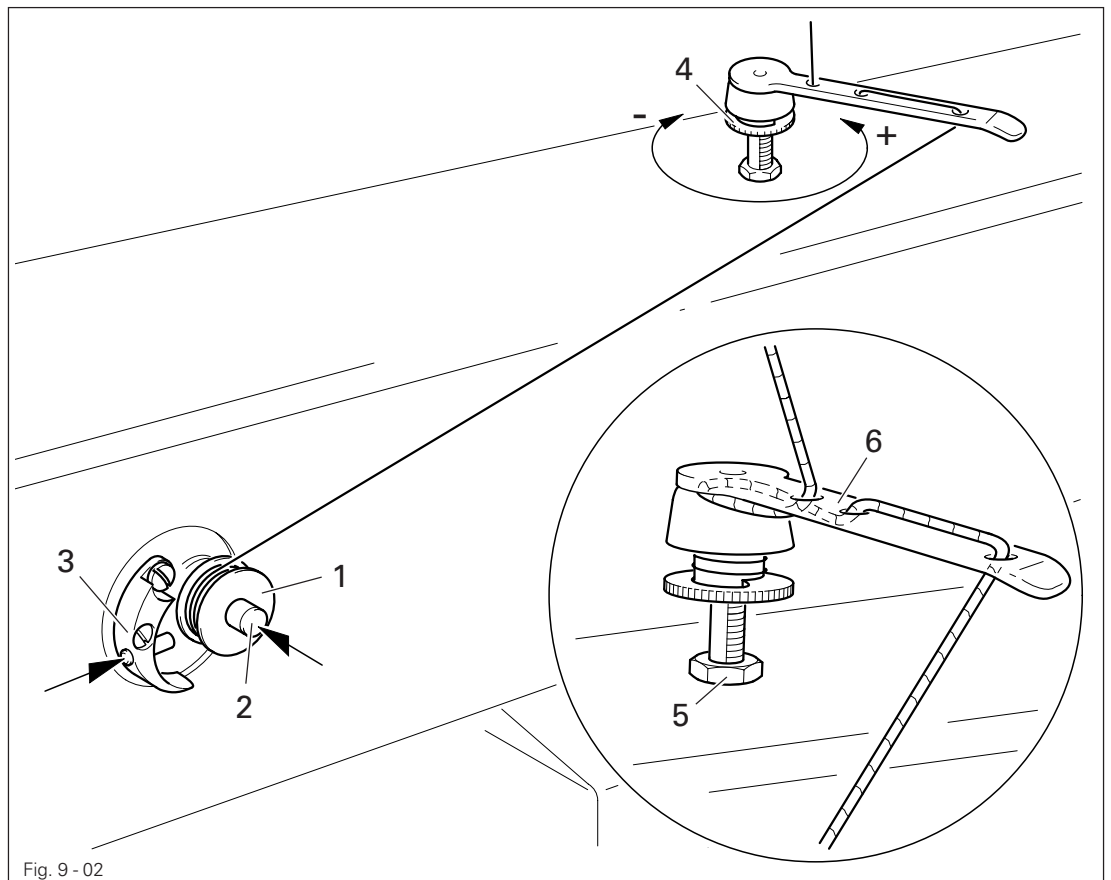

Fig. 9 - 02

- Place an empty bobbin 1 onto bobbin shaft 2.
- Thread the bobbin in accordance with Fig. 9-02 and wind it anti-clockwise around bobbin 1 a few times.
- Switch on the bobbin winder while at the same time pressing bobbin winder spindle 2 and lever 3.



The bobbin fills up during sewing.



If the machine is only being used to wind the bobbin (without sewing), a bobbin case must be inserted in the hook! (Danger of damage to the hook).

- The tension of the thread on bobbin 1 can be adjusted with knurled screw 4.
- The bobbin winder stops automatically when bobbin 1 is full.

If the thread is wound unevenly:

- Loosen nut 5.
- Turn thread guide 6 accordingly.
- Tighten nut 5.

## 9.03 Removing / Inserting the bobbin case

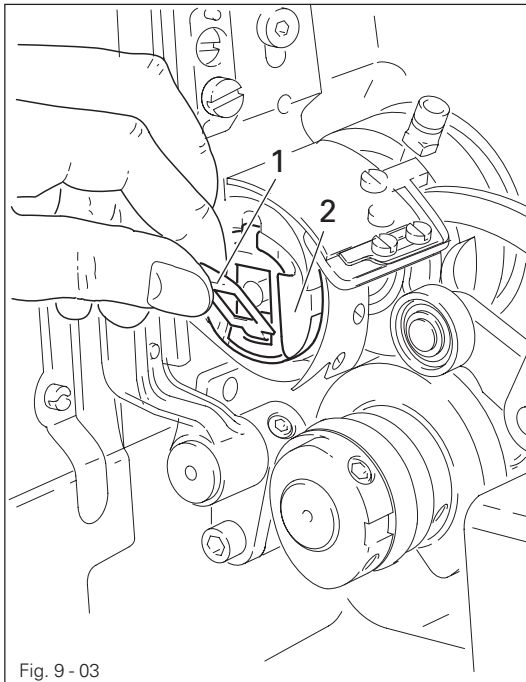

Switch off the machine!  
Danger of injury due to  
unintentional starting of the  
machine!

Removing the bobbin case:

- Tilt back the machine.
- Raise latch 1 and remove bobbin case 2.

Inserting the bobbin case:

- Press bobbin case 2 until you feel it snap into the bobbin case base.



Return the machine to its  
upright position using **both**  
hands!

Danger of injury by crushing  
between the machine and the  
table top!

## 9.04 Inserting the bobbin case / Adjusting the bobbin thread tension

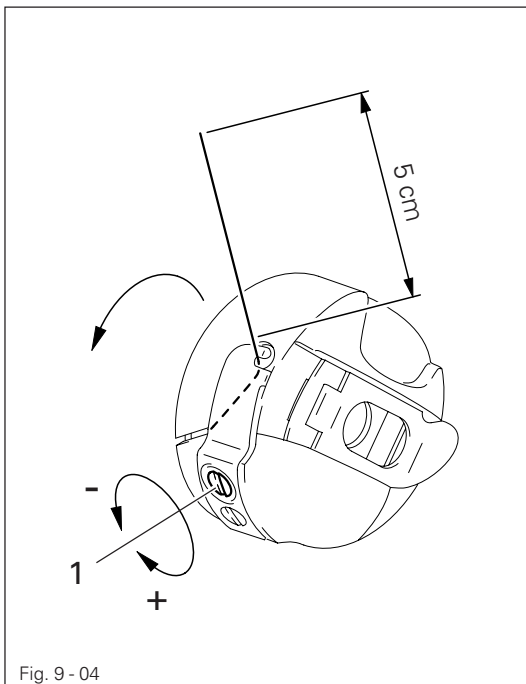

- Insert the bobbin into the bobbin case.
- Pass the thread through the slot under the spring according to Fig. 9-04.
- Pass the thread through the notch.
- Adjust the thread tension by turning screw 1.



When the thread is pulled, the  
bobbin must rotate in the  
direction of the arrow.



9.05 Threading the needle thread / Adjusting the needle thread tension

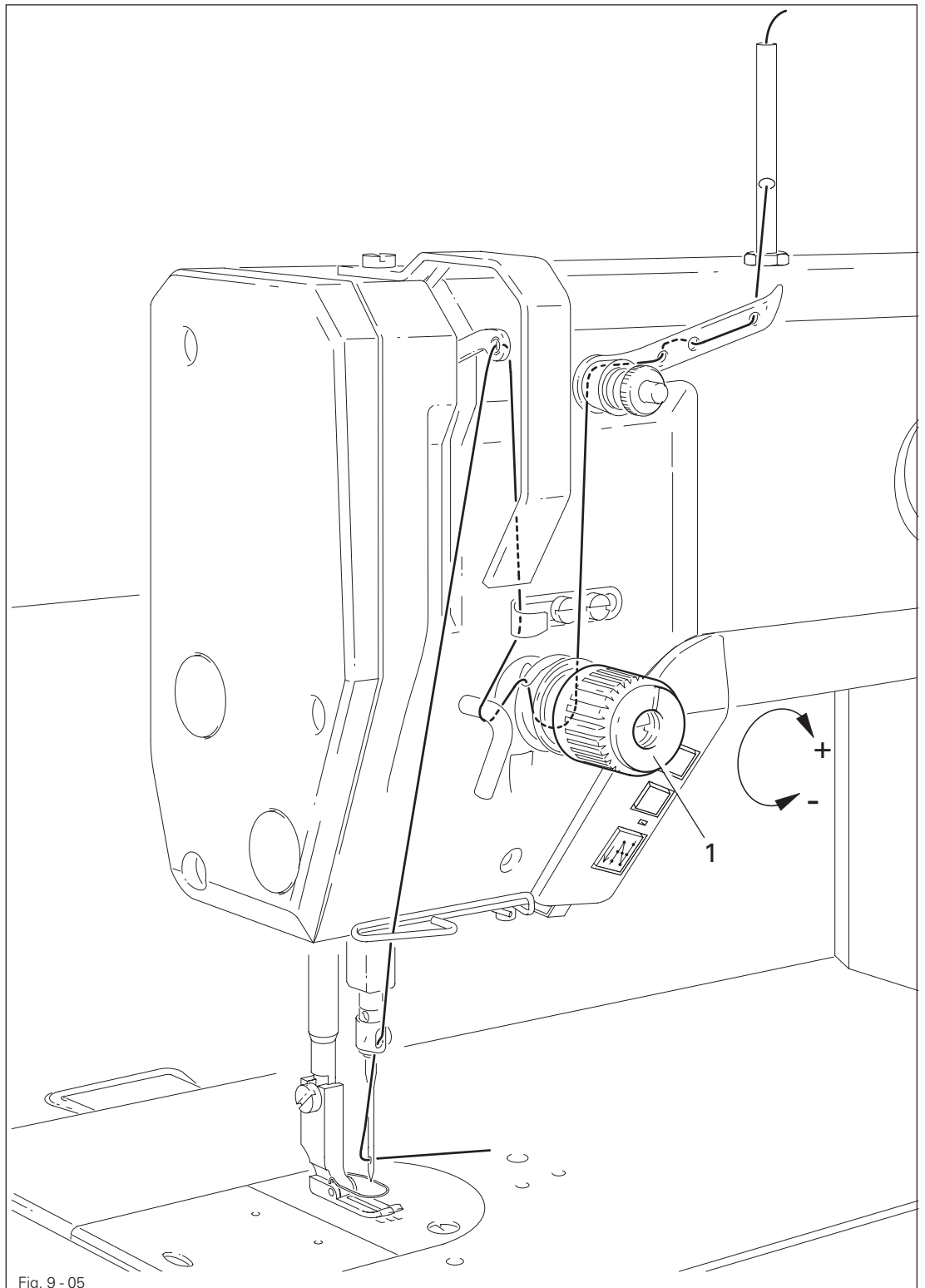

Fig. 9-05



Switch off the machine!  
Danger of injury due to unintentional starting of the machine!

- Thread the machine as shown in Fig. 9-05.
- Adjust the needle thread tension by turning disk 1.

## 9.06 Entering the start and end backtacks

- Switch on the machine.

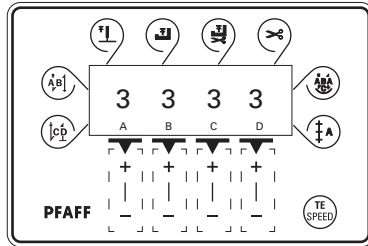

- If necessary switch off the "darning seam" or "counted seam" function, see **Chapter 10.01 Darning program** or **Chapter 10.02 Counted seam**.
- By pressing the corresponding +/- key ("A") select the desired value for the number of forward stitches (A) of the start backtack.
- By pressing the corresponding +/- key ("B") select the desired value for the number of reverse stitches (B) of the start backtack.
- By pressing the corresponding +/- key ("C") select the desired value for the number of reverse stitches (C) of the end backtack.
- By pressing the corresponding +/- key ("D") select the desired value for the number of forward stitches (D) of the end backtack.

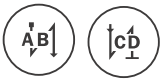

- By pressing the keys **start backtack** and/or **end backtack**, activate the corresponding function (arrow appears next to the corresponding function key).

## 10 Sewing

In the sewing mode all relevant settings for the sewing operation are displayed. Functions can be switched on or off by pressing a key. Values for start and end backtacks or stitch placement can be changed directly.



When the machine is switched on, the sewing mode is always activated.

- Switch on the machine.

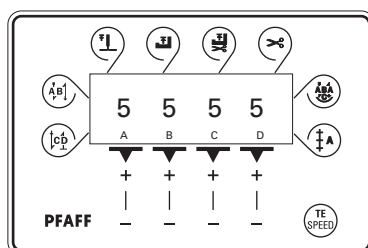

- If necessary switch off the function "darning seam" or "counted seam", see **Chapter 10.01 Darning program** or **Chapter 10.02 Counted seam**.

Functions in manual sewing, also see **Chapter 7.09.02 Function keys**:

	Start backtacks on/off		Presser foot raised at end of seam on/off
	End backtacks on/off		Thread trimming on/off
	Needle position raised on/off		Darning program on/off
	Presser foot raised on/off		Counted seam on/off

Sewing is carried out with the pedal functions, see **Chapter 7.02 Pedal**.



The "Darning program" and "Counted seam" functions are explained in more detail in **Chapter 10.01 Darning program** or **Chapter 10.02 Counted seam**.

## 10.01 Darning program

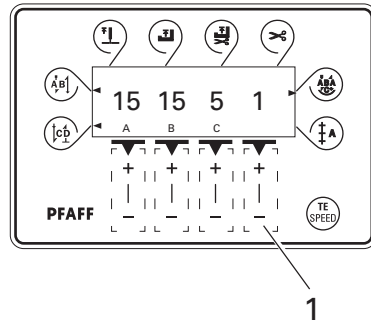

The corresponding function can be switched on or off directly with the **Darning program** key. The "counted seam" function is switched off automatically. Several darning programs with different seam sections A and/or B can be selected. The number of required darning programs can be selected by operating the **+/- key 1**. The number of stitches for the individual seam sections A and/or B can be selected by operating the **corresponding +/- key**. By operating the **corresponding +/- key** it is possible to select a repeating factor "C" for the selected darning program.

If the backtack functions are also activated, only the status backtack on or backtack off is displayed. The individual backtack parameters can be altered after the "darning program" function has been switched off, see **Chapter 9.06 Entering start and end backtacks**.

## 10.02 Counted seam

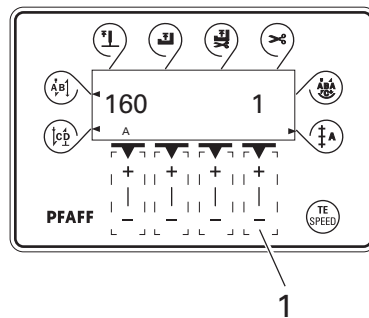

The corresponding function can be switched on or off directly with the **Counted seam** key. The "darning program" function is switched off automatically. Several counted seam sections can be selected. The number of required seam sections can be selected by operating the **+/- key 1**. The required number of stitches "A" of the selected seam section can be selected by operating the **corresponding +/- key**.

If the backtack functions are also activated, only the status backtack on or backtack off is displayed. The individual backtack parameters can be altered after the "counted seam" function has been switched off, see **Chapter 9.06 Entering start and end backtacks**.

### 10.03 Error messages

If a fault occurs, the text "ERROR" appears on the display, together with an error code and short instructions. An error message is caused by incorrect settings, faulty elements or seam programs as well as by overload conditions.

For an explanation of the error codes see **Chapter 10.04 Explanation of the error messages**.

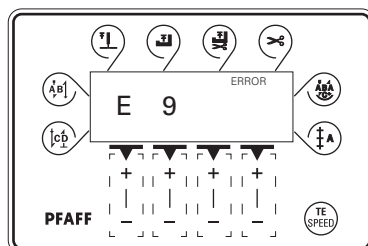

- Correct the error.
- Acknowledge error correction by pressing the **TE/Speed** key.



## 10.04 Explanation of the error signals

Signal	Description
E001	Pedal not in neutral position
E009	Start inhibitor during standstill
E010	Incorrect machine class
E062	Short circuit 24V
E063	Overload mains supply circuit
E064	Network monitoring
E065	Extint low in operation
E066	Short circuit
E067	Network off
E068	Extint low in operation
E069	No increments
E070	Motor blocking
E071	No incremental connector
E074	External transmitter for synchronisation marker missing
E088	RAM defective
E092	Start inhibitor when motor running
E173	Start error

## 10.05 Parameter settings

## 10.05.01 Selecting the user level

- Switch on the machine.

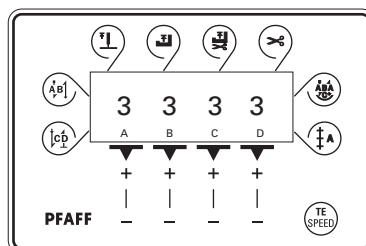
2 x 

- Press the TE/Speed key twice to call up the input mode.

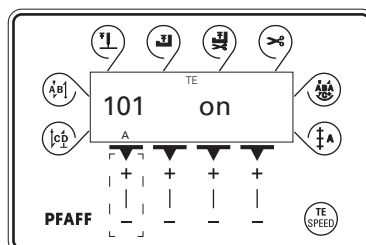

- By pressing the corresponding +/- key select the parameter group "798".

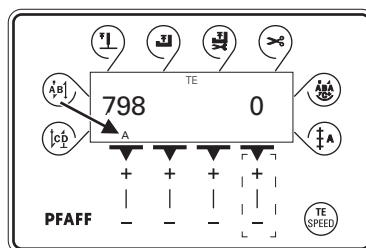

- By pressing the corresponding +/- key select the desired user level:

"0" = operator level A  
 "1" = technician level B  
 "11" = service level C

The selected user level is displayed on the screen. (see arrow)

## 10.05.02 Example of a parameter input

- Switch on the machine.
- Press the **TE/Speed** key twice to select the input mode.

2 x 

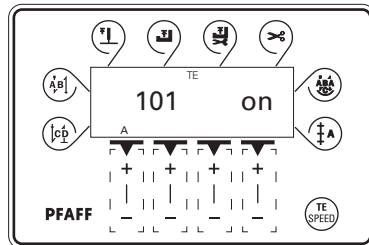

- By pressing the corresponding plus/minus key select parameter "798" and the desired user level, see **Chapter 10.05.01 Selecting the user level**.

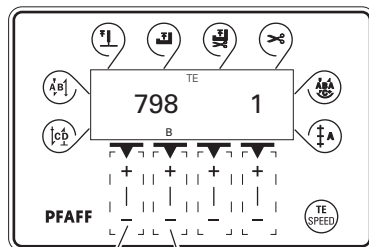

1 2

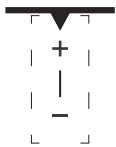

- Select parameter "607" by pressing the corresponding +/- key.

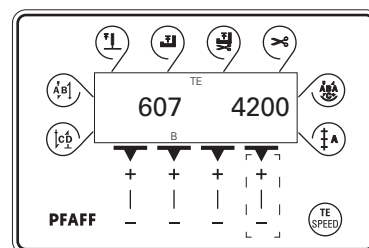

- Select the required value for the maximum speed by pressing the corresponding +/- key.
- By pressing the **TE/Speed** key the selected value is taken over and the machine switches to the sewing mode.





## 10.05.03 Liste der Parameter



Only appropriately trained staff may change the set values in the parameters of user levels "B" and "C".

Gruppe	Parameter	Bedeutung	Nutzer-ebene	Einstellbereich	Einstellwert
1	101	Control panel beep tone	A, B, C		on
6	605	Speed display	B, C		off
	607	Speed max.	B, C	300 - 6000	4000
	609	Cutting speed	B, C	60 - 500	180
	660	Bobbin thread control 0 = off 1 = thread monitor 2 = reverse counter	A,B,C	0 - 2	0
7	700	Needle position 0 (needle reference position)	B,C	0 – 255	
	702	Needle position 1 (needle lowered)	B,C	0 – 255	90
	703	Needle position 2 (take-up lever raised)	B, C	0 - 255	236
	705	Needle position 5 (end of cutting signal 1)	B, C	0 - 255	200
	706	Needle position 6 (start of cutting signal 2)	B, C	0 - 255	136
	707	Needle position 9 (start thread tension release)	B,C	0 - 255	164
	797	Hardwaretest	B, C		off
	798	User level 0 = User level 1 = Technician level 11 = Service level	A,B,C	0,1,11	0
	799	Selected machine class	C	1 - 3	1
8	800	Rotating direction of the motor	C	0 - 1	0



Further parameters are listed in the **Motor Instruction Manual**.

## 11 Care and maintenance

Clean ..... daily, more often if in continuous operation  
Check oil level ..... monthly<sup>▲</sup> (does not apply to the 1181-D and 1183-D)



▲ These maintenance intervals are calculated for the average running time of a single shift operation. If the machine is operated more than this, shorter intervals are recommended.

### 11.01 Cleaning the machine

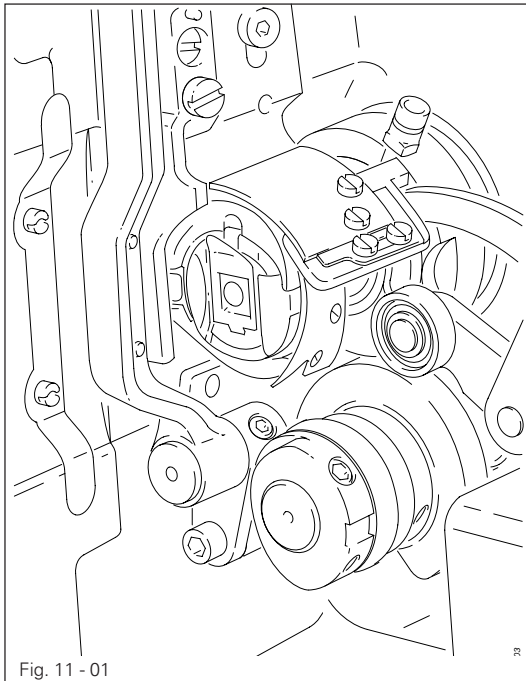

Fig. 11 - 01



Switch off the machine!  
Danger of injury due to unintentional starting of the machine!

- Tilt back the machine.
- Clean the hook and hook compartment daily, more often if in continuous operation.



Return the machine to its upright position using **both** hands!  
Danger of injury by crushing between the edge of the machine and the table top!

## 11.02 Topping up the oil tank (does not apply to the 1181-D and 1183-D)



The PFAFF 1181-D and 1183-D are totally maintenance-free and run without any oil.

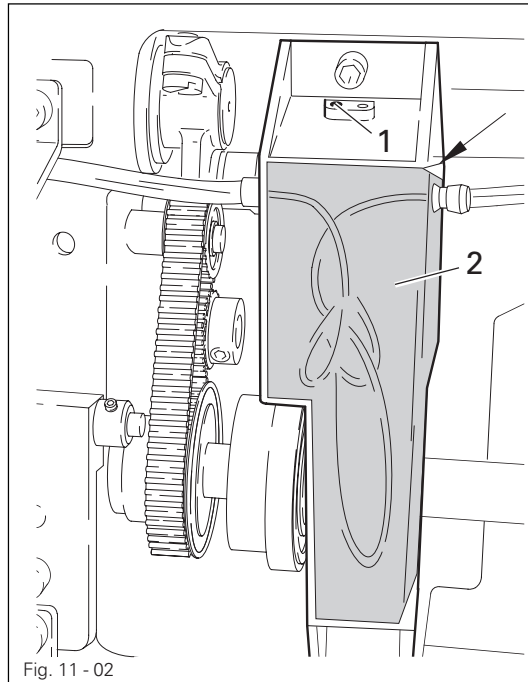

The oil reservoir must always have oil in it.

- Whenever it is necessary to refill the reservoir, tilt back the machine and let it rest on the sewing head support.
- Fill oil through hole 1 into the reservoir 2 up to the level of the front edge (see arrow).

Return the machine to its upright position using **both** hands!



Danger of injury by crushing between the machine and the table top!



Only use oil with a mean viscosity of 10.0 mm<sup>2</sup>/s at 40°C and a density of 0.847 g/cm<sup>3</sup> at 15°C.

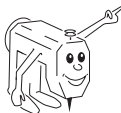

We recommend PFAFF sewing machine oil, part no. 280-1-120 105.

## 12

## Wearing parts



This is a list of the most important wearing parts.

A detailed parts list for the complete machine is included with the accessories.

In case of loss, the parts list can be downloaded from the internet address

[www.pfaff-industrial.com/de/service/download/index.php3](http://www.pfaff-industrial.com/de/service/download/index.php3). As an alternative to the internet download the parts lists can also be ordered in book form

under part no. 296-12-18 709.

### Subclass -731/01

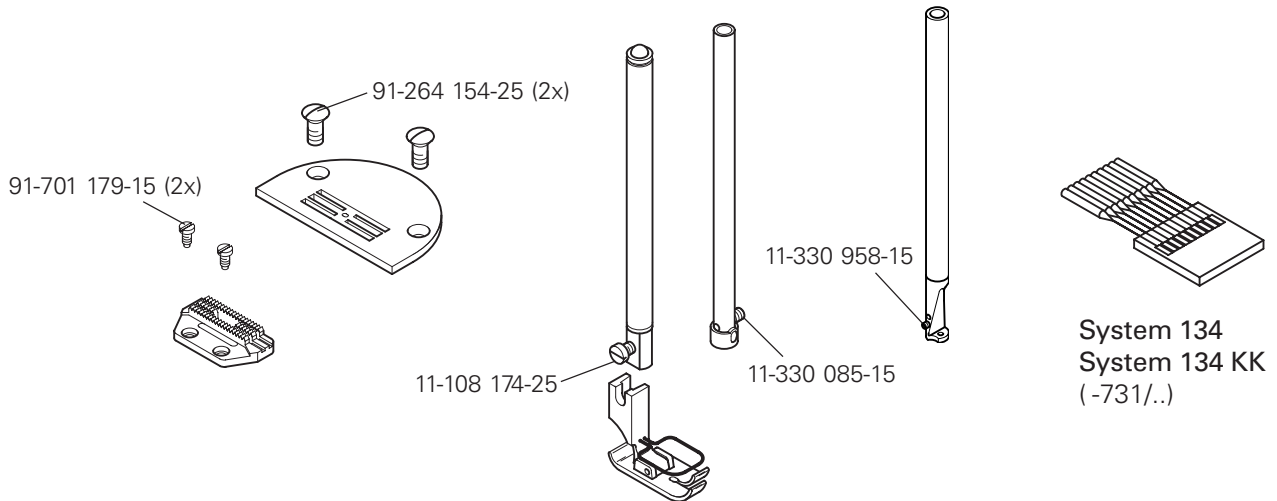

### PFAFF 1181-D; 1183-D

91-264 300-91

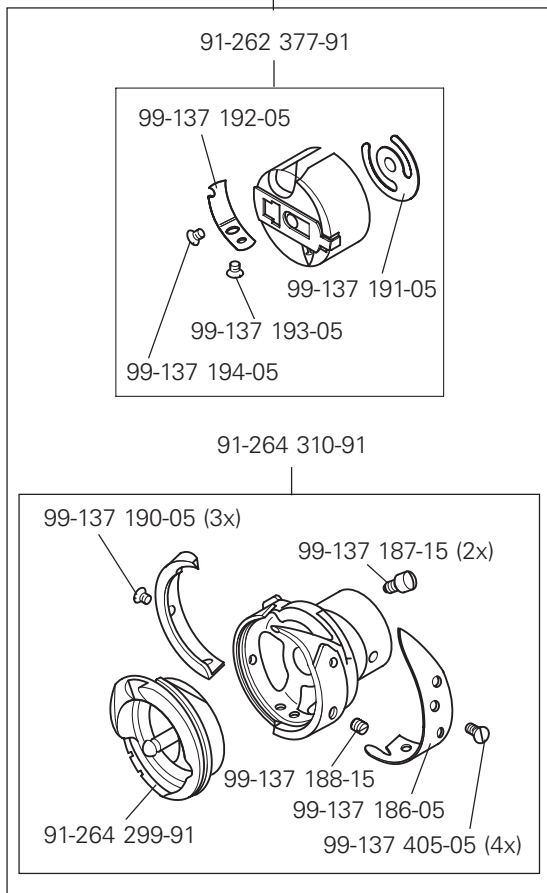

### PFAFF 1181; 1183

91-262 250-91

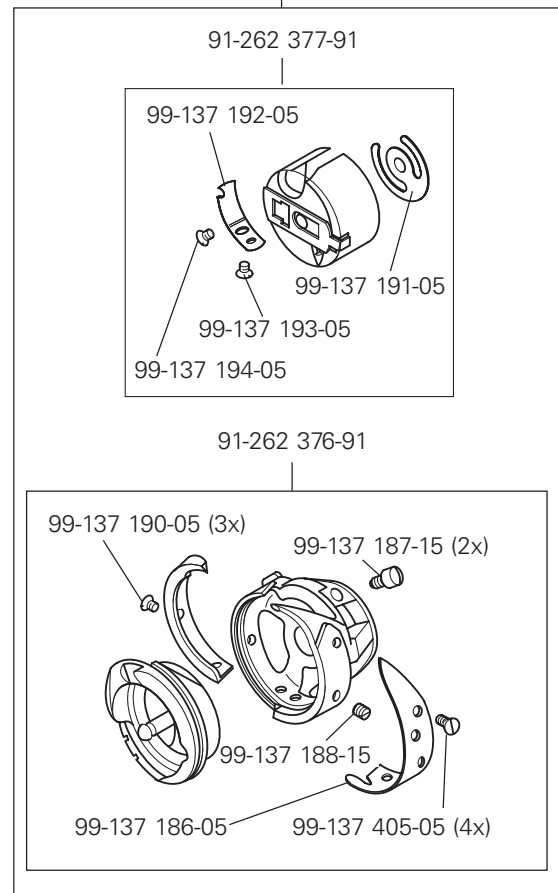

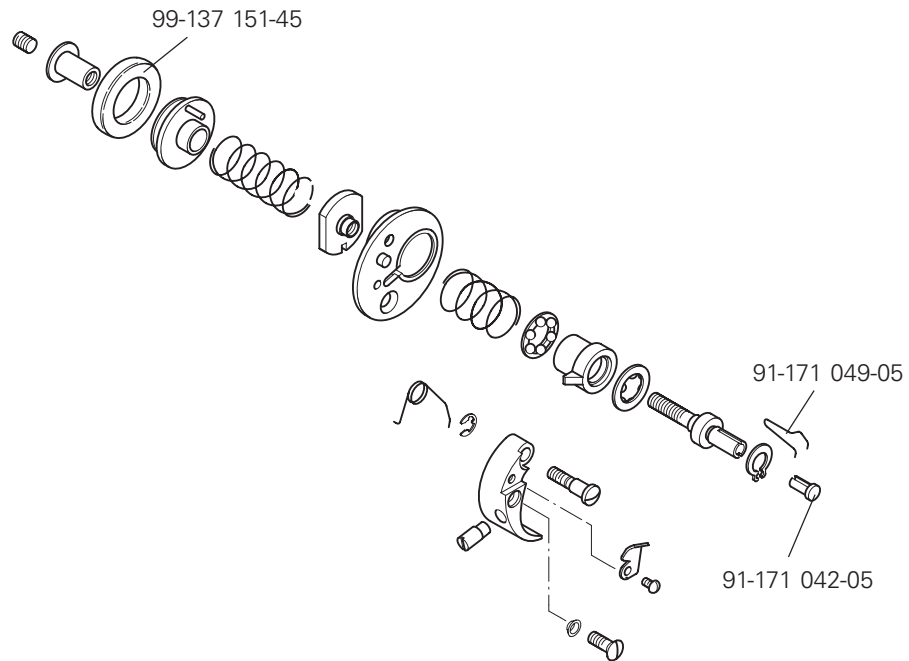
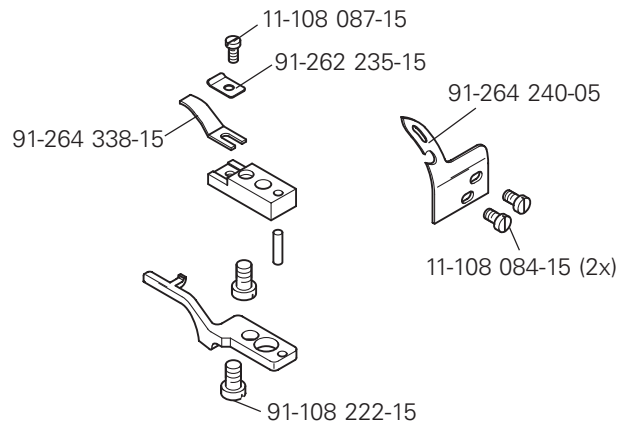

	Subclass	Trimming margin	Partnumber
	-731/01-8/11 A	5,0	91-069 595-04/002
	-731/01-8/11 B	3,5	91-169 395-04/002
	-731/01-8/11 B	4,0 - 7,0	91-069 595-04/002

# PFAFF

## **PFAFF Industrie Maschinen AG**

Postfach 3020  
D-67653 Kaiserslautern

Königstr. 154  
D-67655 Kaiserslautern

Telefon: (0631) 200-0  
Telefax: (0631) 17202  
E-Mail: [info@pfaff-industrial.com](mailto:info@pfaff-industrial.com)