

# PFAFF

1053

1183

Instruction Manual



This Instruction Manual is valid for all models and subclasses listed in the chapter " **Specifications** ".

The reprinting, copying or translation of PFAFF Instruction Manuals, whether in whole or in part, is only permitted with our previous authorization and with written reference to the source.

G.M. PFAFF  
Aktiengesellschaft

Postfach 3020  
D-67653 Kaiserslautern  
Königstr. 154  
D-67655 Kaiserslautern

Editing / Illustrations  
HAAS-Publikationen GmbH  
D-53840 Troisdorf

	Chapter - Page
Contents .....	Chapter - Page
<b>1</b> <b>Safety</b> .....	<b>1 - 1</b>
1.01    Directives .....	1 - 1
1.02    General notes on safety .....	1 - 1
1.03    Safety symbols .....	1 - 2
1.04    Important points for the user .....	1 - 2
1.05    Operating and specialist personnel .....	1 - 3
1.05.01    Operating personnel .....	1 - 3
1.05.02    Specialist personnel .....	1 - 3
1.06    Danger .....	1 - 4
<b>2</b> <b>Proper use</b> .....	<b>2 - 1</b>
<b>3</b> <b>Specifications</b> .....	<b>3 - 1</b>
3.01    PFAFF 1053, PFAFF 1183 .....	3 - 1
3.02    Models and subclasses .....	3 - 2
<b>4</b> <b>Disposal of the machine</b> .....	<b>4 - 1</b>
<b>5</b> <b>Transport, packaging and storage</b> .....	<b>5 - 1</b>
5.01    Transport to the customer .....	5 - 1
5.02    Transport within the customer's premises .....	5 - 1
5.03    Disposal of the packaging .....	5 - 1
5.04    Storage .....	5 - 1
<b>6</b> <b>Explanation of the symbols</b> .....	<b>6 - 1</b>
<b>7</b> <b>Controls</b> .....	<b>7 - 1</b>
7.01    On/off switch .....	7 - 1
7.02    Keys on the machine head .....	7 - 1
7.03    Pedal .....	7 - 2
7.04    Lever for lifting the presser foot .....	7 - 2
7.05    Feed regulator disk .....	7 - 3
7.06    Reverse feed lever .....	7 - 3
7.07    Knee lever .....	7 - 4
7.08    Switch for thread wiper -909/04 .....	7 - 4
<b>8</b> <b>Mounting and commissioning the machine</b> .....	<b>8 - 1</b>
8.01    Mounting .....	8 - 1
8.01.01    Adjusting the table-top height .....	8 - 1
8.01.02    Adjusting the V-belt tension .....	8 - 2
8.01.03    Mounting the upper V-belt guard .....	8 - 2
8.01.04    Mounting the lower V-belt guard .....	8 - 3
8.01.05    Mounting the spool holder and the sewing lamp .....	8 - 3
8.02    Commissioning the machine .....	8 - 4
8.03    Turning the machine on/off .....	8 - 4

	Contents .....	Chapter - Page
<b>9</b>	<b>Preparation .....</b>	<b>9 - 1</b>
9.01	Inserting the needle .....	9 - 1
9.02	Winding the bobbin thread/ adjusting the thread tension .....	9 - 2
9.03	Removing/Inserting the bobbin case .....	9 - 3
9.04	Inserting the bobbin case / Adjusting the bobbin thread tension .....	9 - 3
9.05	Threading the needle thread / Adjusting the needle thread tension .....	9 - 4
9.06	Adjusting the stitch length .....	9 - 5
<b>10</b>	<b>Care and maintenance .....</b>	<b>10 - 1</b>
10.01	Cleaning the machine .....	10 - 1
10.02	Filling the oil reservoir (PFAFF 1183 only) .....	10 - 2
<b>11</b>	<b>Adjustment .....</b>	<b>11 - 1</b>
11.01	Notes on adjusting .....	11 - 1
11.02	Tools, gauges and other accessories for adjusting .....	11 - 1
11.03	Abbreviations .....	11 - 1
11.04	Checking and adjusting aids .....	11 - 2
<b>11.05</b>	<b>Adjusting the basic machine .....</b>	<b>11 - 3</b>
11.05.01	Basic position of the machine drive (for 220 V built-in motors only) .....	11 - 3
11.05.02	Preadjusting the needle height .....	11 - 4
11.05.03	Neutralizing the feed dog movement .....	11 - 5
11.05.04	Feed lifting motion .....	11 - 6
11.05.05	Feed dog height .....	11 - 7
11.05.06	Feed dog motion .....	11 - 8
11.05.07	Needle in needle hole center .....	11 - 9
11.05.08	Hook shaft bearing and backlash .....	11 - 10
11.05.09	Hook lubrication (for PFAFF 1183 only) .....	11 - 11
11.05.10	Needle rise, hook-to-needle clearance, needle height and bobbin case position finger .....	11 - 12
11.05.11	Thread tension release (machines without -900/...) .....	11 - 13
11.05.12	Thread check spring and slack thread regulator .....	11 - 14
11.05.13	Position of knee lever .....	11 - 15
11.05.14	Knee lever stop .....	11 - 16
11.05.15	Bobbin winder .....	11 - 17
11.05.16	Limiting the stitch length .....	11 - 18
11.05.17	Presser foot pressure .....	11 - 19
11.05.18	Modifying the needle bar stroke .....	11 - 20
<b>11.06</b>	<b>Adjusting the thread trimmers -900/22 and -900/24 .....</b>	<b>11 - 21</b>
11.06.01	Magnet setting .....	11 - 21
11.06.02	Lateral alignment of the thread catcher .....	11 - 22
11.06.03	Knife position .....	11 - 23
11.06.04	Front point of reversal of the thread catcher .....	11 - 24
11.06.05	Manual trimming check .....	11 - 25
11.06.06	Thread tension release .....	11 - 26
11.06.07	Readjusting the control cam .....	11 - 27

	Contents .....	Chapter - Page
<b>11.07</b>	<b>Adjusting the thread wiper -909/04 .....</b>	<b>11 - 28</b>
11.07.01	Thread wiper movement .....	11 - 28
11.07.02	Thread wiper position .....	11 - 29
<b>11.08</b>	<b>Adjusting the automatic presser foot lift -910/06 .....</b>	<b>11 - 30</b>
<b>11.09</b>	<b>Adjusting the backtacking mechanism -911/37 .....</b>	<b>11 - 31</b>

## 1 Safety

### 1.01 Directives

This machine is constructed in accordance with the European regulations contained in the conformity and manufacturer's declarations.

In addition to this Instruction Manual, also observe all generally accepted, statutory and other regulations and legal requirements and all valid environmental protection regulations! The regionally valid regulations of the social insurance society for occupational accidents or other supervisory organizations are to be strictly adhered to!

### 1.02 General notes on safety

- This machine may only be operated by adequately trained operators and only after having completely read and understood the Instruction Manual!
- All Notes on Safety and Instruction Manuals of the motor manufacturer are to be read before operating the machine!
- The danger and safety instructions on the machine itself are to be followed!
- This machine may only be used for the purpose for which it is intended and may not be operated without its safety devices. All safety regulations relevant to its operation are to be adhered to.
- When exchanging sewing tools (e.g. needle, roller presser, needle plate and bobbin), when threading the machine, when leaving the machine unattended and during maintenance work, the machine is to be separated from the power supply by switching off the On/Off switch or by removing the plug from the mains!
- Everyday maintenance work is only to be carried out by appropriately trained personnel!
- Repairs and special maintenance work may only be carried out by qualified service staff or appropriately trained personnel!
- Work on electrical equipment may only be carried out by appropriately trained personnel!
- Work is not permitted on parts and equipment which are connected to the power supply! The only exceptions to this rule are found in the regulations EN 50110.
- Modifications and alterations to the machine may only be carried out under observance of all the relevant safety regulations!

- Only spare parts which have been approved by us are to be used for repairs! We expressly point out that any replacement parts or accessories which are not supplied by us have not been tested and approved by us. The installation and/or use of any such products can lead to negative changes in the structural characteristics of the machine. We are not liable for any damage which may be caused by non-original parts.

## 1.03 Safety symbols



Danger!  
Points to be observed.



Danger of injury for operating and specialist personnel!

## 1.04 Important points for the user

- This Instruction Manual is an integral part of the machine and must be available to the operating personnel at all times.
- The Instruction Manual must be read before operating the machine for the first time.
- The operating and specialist personnel is to be instructed as to the safety equipment of the machine and regarding safe work methods.
- It is the duty of the user to only operate the machine in perfect running order.
- It is the obligation of the user to ensure that none of the safety mechanisms are removed or deactivated.
- It is the obligation of the user to ensure that only authorized persons operate and work on the machine.

Further information can be obtained from your PFAFF agent.

## 1.05 Operating and specialist personnel

### 1.05.01 Operating personnel

Operating personnel are persons responsible for the equipping, operating and cleaning of the machine as well as for taking care of problems arising in the sewing area.

The operating personnel is required to observe the following points and must:

- always observe the Notes on Safety in the Instruction Manual!
- never use any working methods which could adversely affect the safety of the machine!
- not wear loose-fitting clothing or jewelery such as chains or rings!
- also ensure that only authorized persons have access to the potentially dangerous area around the machine!
- always immediately report to the person responsible any changes in the machine which may limit its safety!

### 1.05.02 Specialist personnel

Specialist personnel are persons with a specialist education in the fields of electrics, electronics and mechanics. They are responsible for the lubrication, maintenance, repair and adjustment of the machine.

The specialist personnel is obliged to observe the following points and must:

- always observe the Notes on Safety in the Instruction Manual!
- switch off the On/Off switch before carrying out adjustments or repairs, and ensure that it cannot be switched on again unintentionally!
- wait until the luminous diode on the control box is no longer blinking or on before beginning adjustment or repair work.
- never work on parts which are still connected to the power supply! Exceptions are explained in the regulations EN 50110.
- replace the protective coverings and close the electrical control box after all repairs or maintenance work!



1.06

Danger



A working area of 1 meter is to be kept free both in front of and behind the machine while it is in operation so that it is always easily accessible.



Never reach into the sewing area while sewing! Danger of injury by the needle!



Never leave objects on the table while adjusting the machine settings! Objects can become trapped or be slung away! Danger of injury!

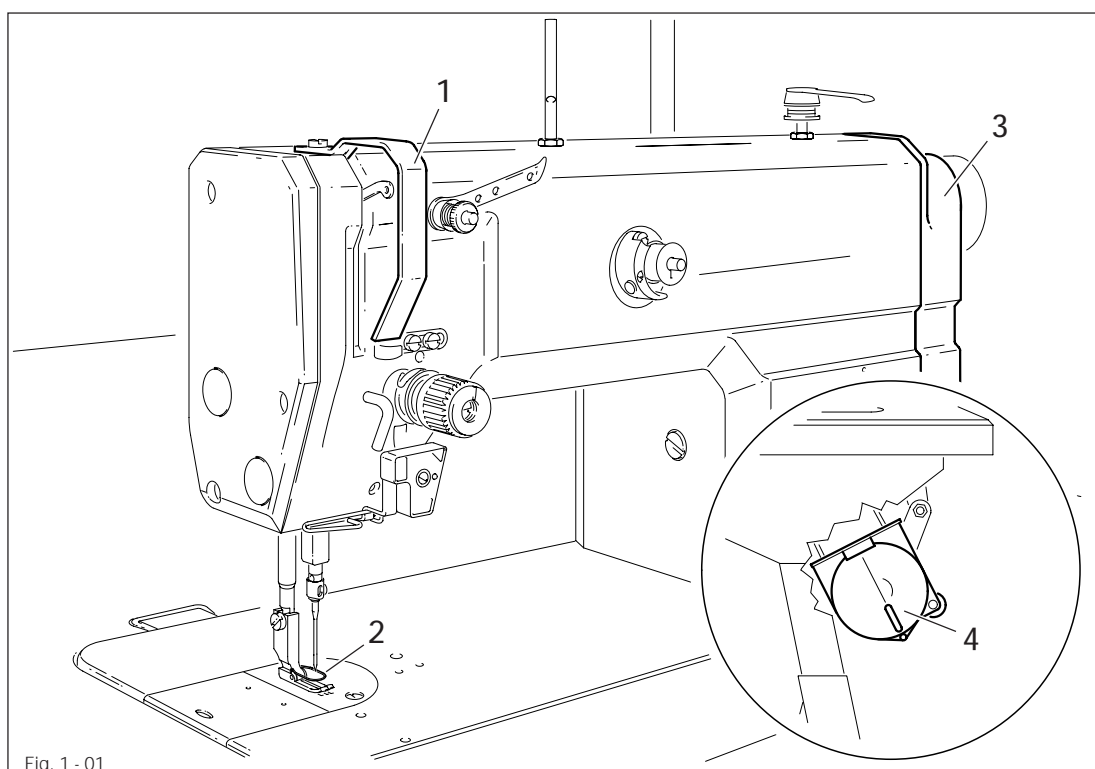

Fig. 1 - 01



Do not operate the machine without its take-up lever guard 1!  
Danger of injury due to the motion of the take-up lever!



Do not operate the machine without the finger guard 2!  
Danger of injury by the needle!



If an external motor is used, do not operate the machine without the belt guards 3 and 4!  
Danger of injury by the drive belt!

### 2 Proper use

The PFAFF 1053 is an oil-free, single needle plain seamer with bottom feed.

The PFAFF 1183 is a high-speed, single needle plain seamer with bottom feed.

These machines are used in the textile industry for sewing lockstitch seams.



Any and all uses of this machine which have not been approved of by the manufacturer are considered to be inappropriate! The manufacturer cannot be held liable for any damage caused by the inappropriate use of the machine! The appropriate use of the machine includes the observance of all operational, adjustment, maintenance and repair measures required by the manufacturer!

3 Specifications

3.01 PFAFF 1053, PFAFF 1183 ▲

Stitch type: ..... 301 (lockstitch)  
 Needle system: ..... DBx1  
 Needle thickness (Nm) in 1/100 mm:  
 Subclass 8/31: ..... 60-90  
 Subclass 8/33: ..... 100-120  
 Handwheel eff. dia.: ..... 65 mm  
 Clearance under the presser foot: ..... 9-13 mm  
 Clearance width: ..... 260 mm  
 Clearance height: ..... 125 mm  
 Bedplate dimensions: ..... 476 x 177 mm

Dimensions of sewing head:

Length: approx. .... 550 mm  
 Width: approx. .... 180 mm  
 Height (above table): approx. .... 300 mm

Max. speed:

Subclass 8/31: ..... 4.5 mm  
 Subclass 8/33: ..... 5.2 mm

Max. Stichzahl:

PFAFF 1053 ..... 4000 Sti/min ♦  
 PFAFF 1183 ..... 5500 Sti/min ♦

Needle bar stroke: ..... 32 or 36 mm

Electrical data:

Operating voltage: ..... 190 - 240 V 50/60 Hz, 1 phase  
 Max. output: ..... 400 VA  
 Fuse protection: ..... 1 x 16 A, delayed action

Working noise level - PFAFF 1053:

Emission at workplace at n = 3200 spm: ..... 76 dB(A)  
 (Noise measurement in accordance with DIN 45 635-48-A-1)

Working noise level - PFAFF 1183:

Emission at workplace at n = 4400 spm: ..... 81 dB(A)  
 (Noise measurement in accordance with DIN 45 635-48-A-1)

Net weight of machine head: approx. .... 30 kg

Gross weight of machine head: approx. .... 38 kg

▲ Subject to alteration

♦ Varies according to material, work process and stitch length

## 3.02 Models and subclasses

Subclass 8/31: ..... for processing fine materials  
Subclass 8/33: ..... for processing medium materials  
Subclass 944/01: ..... for processing leather and similar materials

### Work aids:

Subclass -900/22 ..... thread trimmer (220 V)  
Subclass -900/24 ..... thread trimmer (24 V)  
Subclass -909/04 ..... thread wiper  
Subclass -910/06 ..... automatic presser foot lift  
Subclass -911/37 ..... backtacking mechanism

### 4 Disposal of machine

- The proper disposal of the machine is the responsibility of the customer.
- The materials used in the machines are steel, aluminium, brass and various plastics. The electrical equipment consists of plastics and copper.
- The machine is to be disposed of in accordance with the locally valid environmental protection regulations. If necessary, a specialist is to be commissioned.



Special care is to be taken that parts soiled with lubricants are separately disposed of in accordance with the locally valid pollution control regulations!

### 5 Transport, packaging and storage

#### 5.01 Transport to the customer's premises

Within Germany, machines with a table are delivered without packaging. Machines without a table (sewing head only) and machines which are to be exported are packaged.

#### 5.02 Transport within the customer's premises

The manufacturer bears no liability for transport within the customer's premises or to the individual locations of use. Make sure that the machines are always transported upright.

#### 5.03 Disposal of the packaging

The packaging of these machines consists of paper, cardboard and VCE fiber. The proper disposal of the packaging is the responsibility of the customer.

#### 5.04 Storage

The machine can be stored for up to 6 months if not in use. During this time it should be protected from dust and moisture.

For longer storage the individual parts of the machine, especially the moving parts, must be protected from corrosion, e.g. by a film of oil.

### 6 Explanation of the symbols

In the following section of this Instruction Manual, certain tasks or important pieces of information are accentuated by symbols.

The symbols used have the following meanings:



Note, information



Cleaning, care



Lubrication, greasing

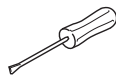

Servicing, repairing, adjustment, maintenance  
(only to be carried out by specialist personnel)

## 7 Controls

### 7.01 On/Off switch

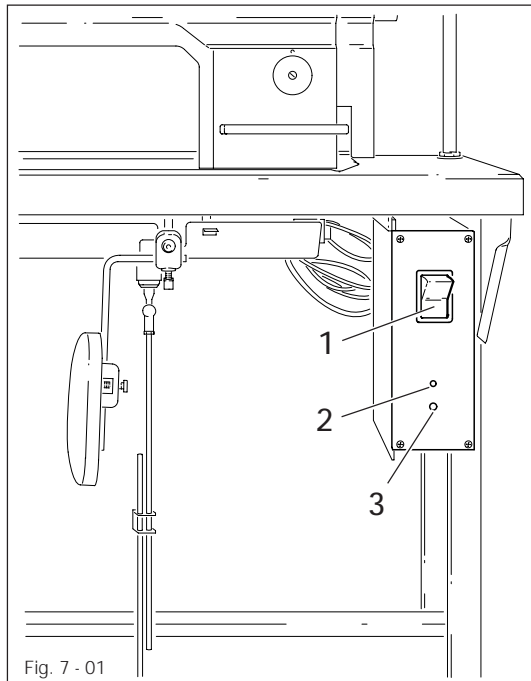

- Turn the machine on/off by pressing the On/Off switch 1.
- LED 2 is for monitoring the machine controller.

#### Switch 1 on:

- LED ON = controller operative
- LED blinking = malfunction

#### Switch 1 off:

- LED blinking = controller will remain live for approx. 4 seconds
- LED off = controller off

- The machine speed can be adjusted via potentiometer 3.

### 7.02 Keys on the machine head

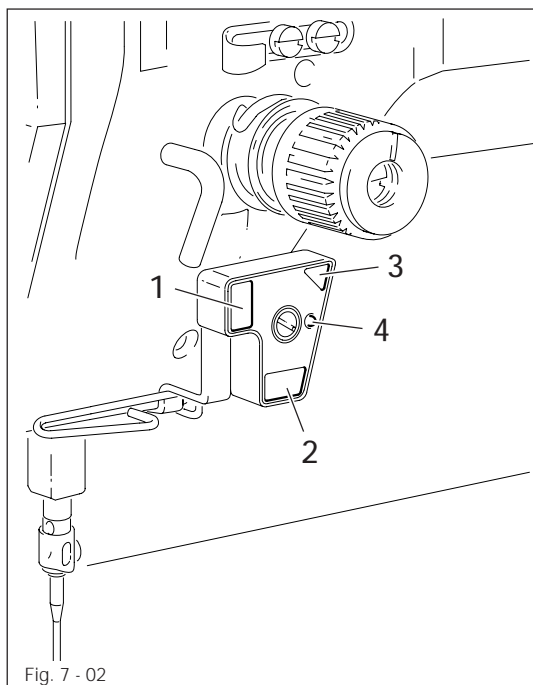

- The following functions are triggered by pressing the corresponding keys.

Key 1: When sewing is interrupted, the needle can be either raised or lowered as required.

Key 2: reverse sewing

Key 3: Prevent automatic start backtack or finish backtack (diode 4 is lit when function is active).



7.03

Pedal

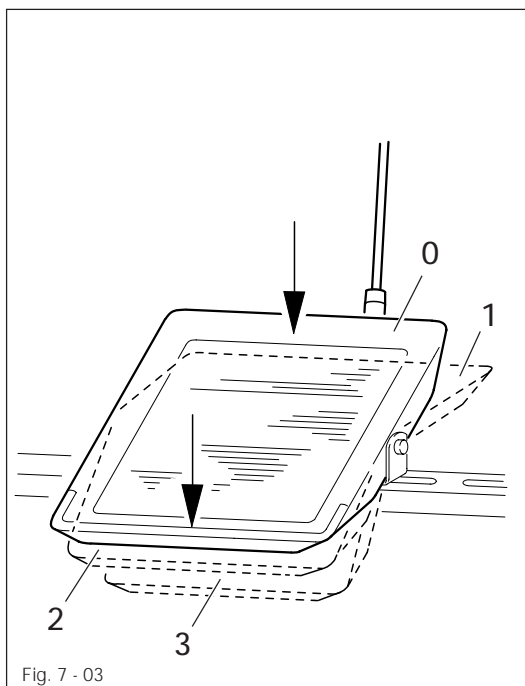

Fig. 7 - 03

- 0 = Machine stop
- 1 = Sew
- 2 = Raise presser foot (for machines with -910/06)
- 3 = Trim thread (for machines with -900/22 or -900/24)

7.04

Lever for lifting the presser foot

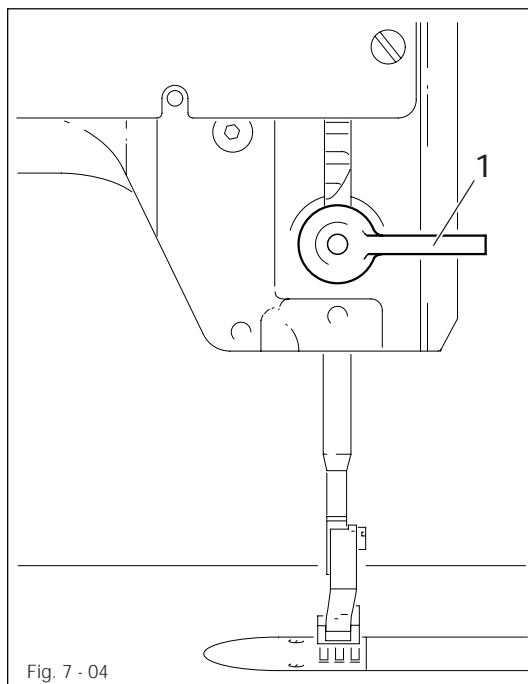
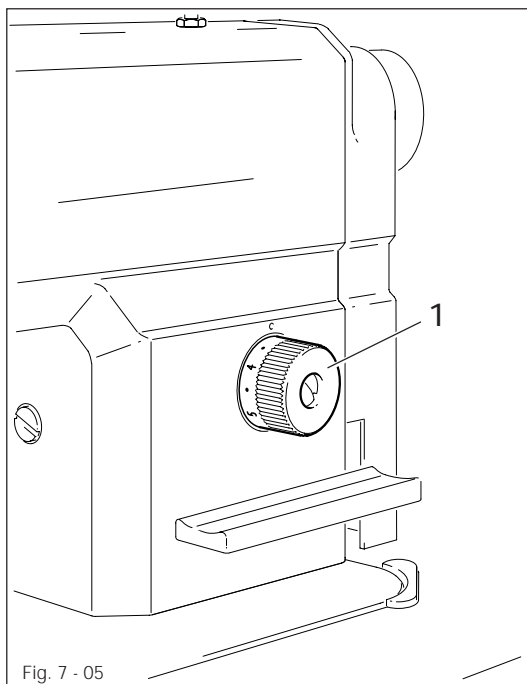

Fig. 7 - 04

- The presser foot is raised by turning lever 1.

## 7.05 Feed regulator disk



- The stitch length can be set by simultaneously applying pressure to disk 1 and turning it to the desired setting.

## 7.06 Reverse feed lever

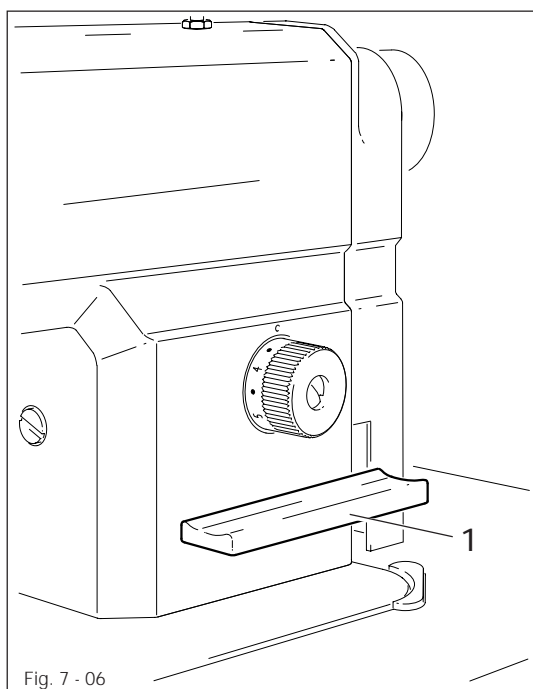

- For reverse sewing press lever 1.

7.07

Knee lever

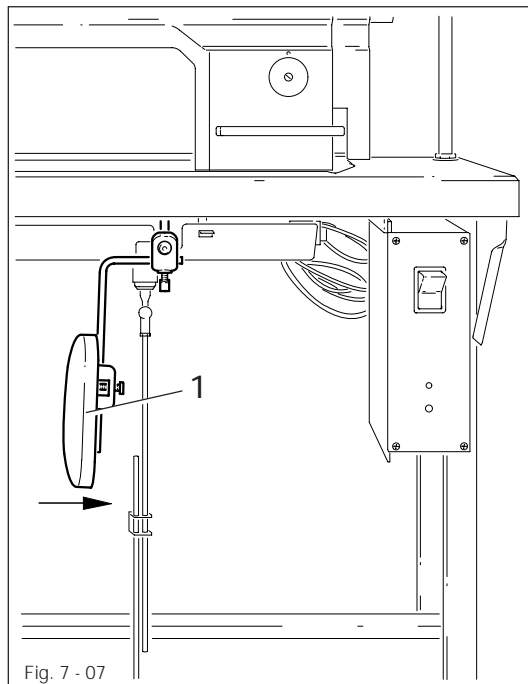

- By pressing the knee lever 1 in the direction of the arrow, the presser foot is raised.

7.08

Switch for thread wiper -909/04

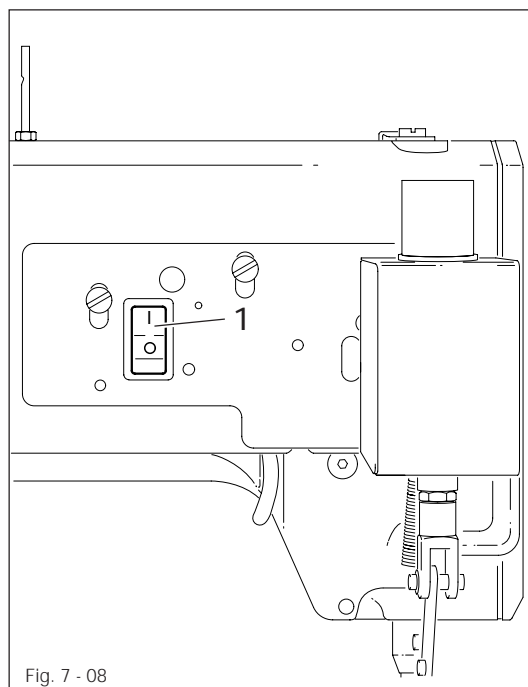

- By moving switch 1, the thread wiper can be switched on or off.

Position I : aggregate is on

Position 0 : aggregate is off

# Mounting and commissioning the machine

## 8 Mounting and commissioning the machine



The machine must only be mounted and commissioned by qualified personnel! All relevant safety regulations are to be observed!



If the machine is delivered without a table, be sure that the frame and the table top which you intend to use can hold the weight of the machine and the motor. It must be ensured that the supporting structure is sufficiently sturdy, even during sewing operations.

### 8.01 Mounting

The necessary electricity supply must be available at the machine's location. Also, a stable and horizontal surface as well as adequate lighting are required at the location.



Depending on the type of table, the method of packaging used may require that the table top be lowered for transport. The following is a description of how to adjust the height of the table top.

#### 8.01.01 Adjusting the table-top height

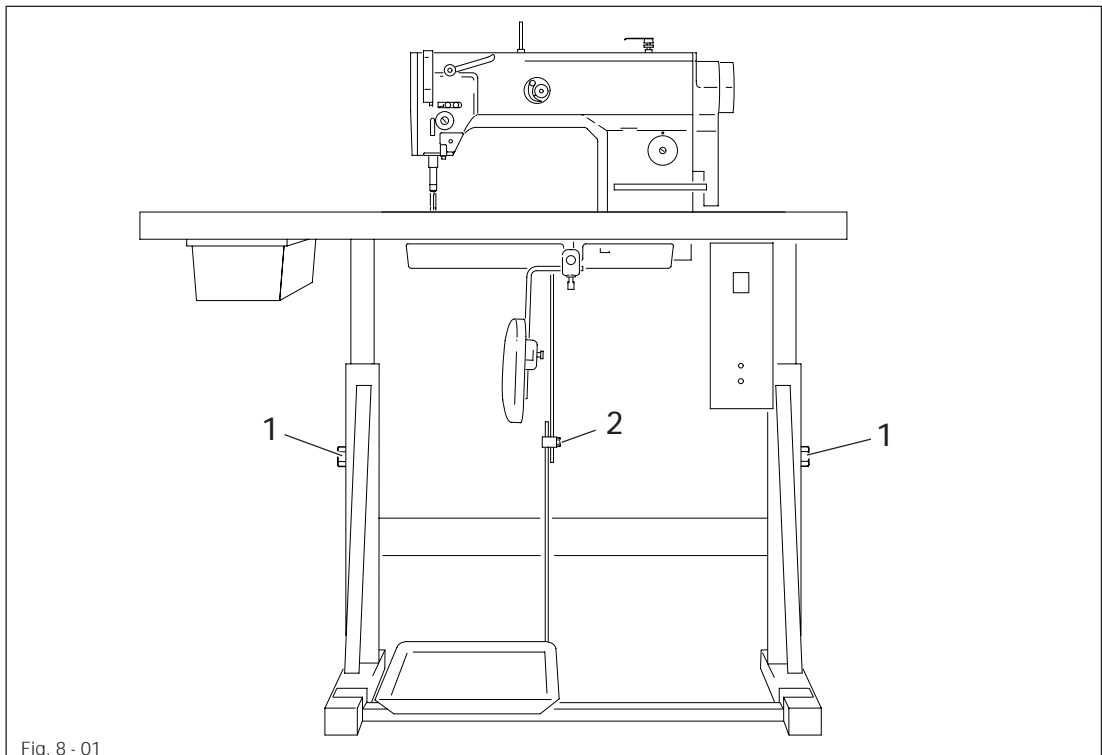

Fig. 8 - 01

- Loosen screws 1 and 2 and set the desired table-top height
- Tighten screws 1 well.
- Adjust the pedal to the desired position and tighten screw 2.

## 8.01.02 Adjusting the V-belt tension



This step is eliminated for integrated sewing motors.

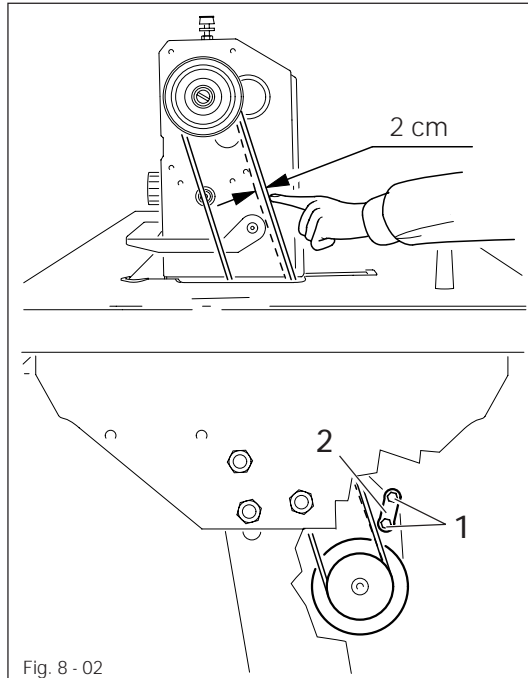

Fig. 8 - 02

- Loosen nuts 1.
- Tighten the V-belt with belt take-up hanger 2.
- Tighten nuts 1.



A quick motor is shown in Fig. 8-02. If another motor is used, carry out this step according to the instructions in the motor instruction manual.

## 8.01.03 Mounting the upper V-belt guard



This step is eliminated for integrated sewing motors.

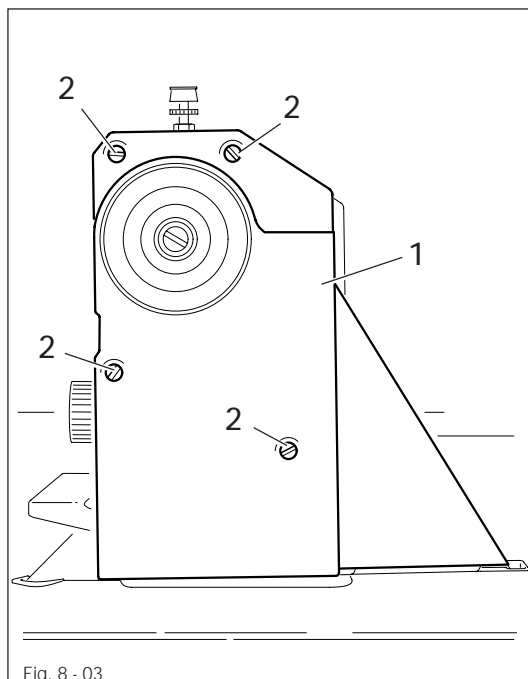

Fig. 8 - 03

- Screw belt guard 1 onto the machine housing with the screws 2.

# Mounting and commissioning the machine

## 8.01.04 Mounting the lower V-belt guard



This step is eliminated for integrated sewing motors.

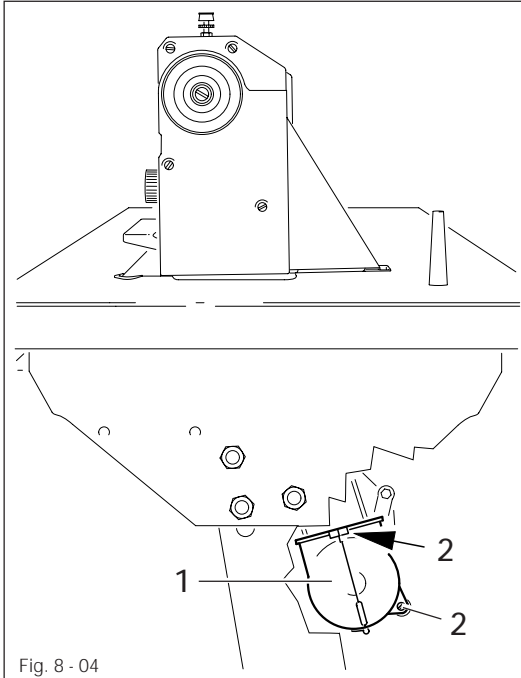

- Align belt-guard 1 in such a way that both the motor pulley and the V-belt run freely.
- Tighten screws 2.



A quick motor is shown in Fig. 8-04. If another motor is used, carry out this step according to the instructions in the motor instruction manual.

## 8.01.05 Mounting the spool holder and the sewing lamp

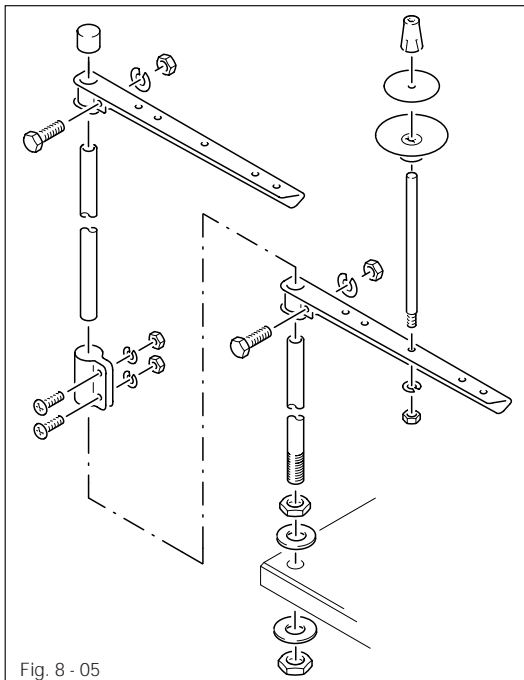

- Mount the spool holder as shown in Fig. 8-05.
- Insert the spool holder into the hole in the table top and fasten it with the nuts enclosed.
- Screw sewing lamp onto the table top with the wood screws and have it connected by specialist personnel.

## 8.02 Commissioning the machine

- Check the machine, especially the electrical leads, for any damage.
- Clean the machine thoroughly (see chapter 10 Care and maintenance).
- Have specialists ensure that the machine's motor can be operated with the available electricity supply and that it is connected properly. If not, the machine **must not** be operated.

## 8.03 Turning the machine on/off

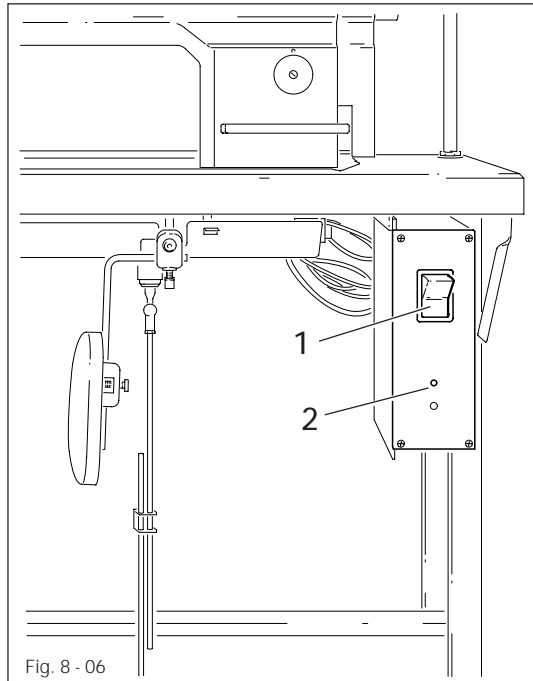

- Turn the machine on/off by pressing the switch 1.
- LED 2 is for monitoring the machine controller.

### Switch 1 on:

- |              |   |                      |
|--------------|---|----------------------|
| LED ON       | = | controller operative |
| LED blinking | = | malfunction          |

### Switch 1 off:

- |              |   |   |
|--------------|---|---|
| LED blinking | = | controller will remain live for approx. 4 seconds |
| LED off      | = | controller off                                    |



Refer to the instruction manual of the motor for a description of additional functions.

9

## Preparation



All regulations and instructions in this Instruction Manual are to be observed!  
Special attention is to be paid to the safety regulations!



All preparation work is only to be carried out by appropriately trained personnel.  
Before all preparation work, the machine is to be separated from the electricity supply by removing the plug from the mains or switching off the On/Off switch!

9.01

## Inserting the needle

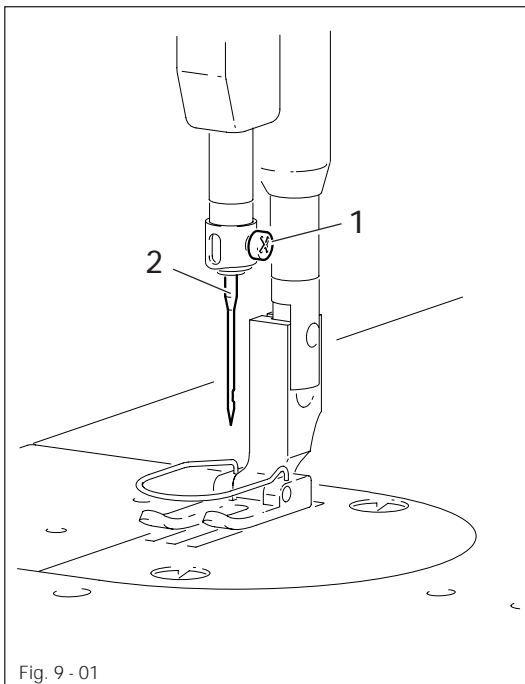

Turn the machine off!  
Danger of injury if machine suddenly starts running!

Use only needles of the system DB x 1.

- Raise needle bar.
- Loosen screw 1 and insert needle 3 until you feel it stop.
- The long needle groove must be aligned in the direction of the machine head.
- Tighten screw 1.



The selection of the correct needle depends on the model of the machine and the material and threads being sewn (see chapter 3 Specifications).



9.02

## Winding the bobbin thread, adjusting the thread tension

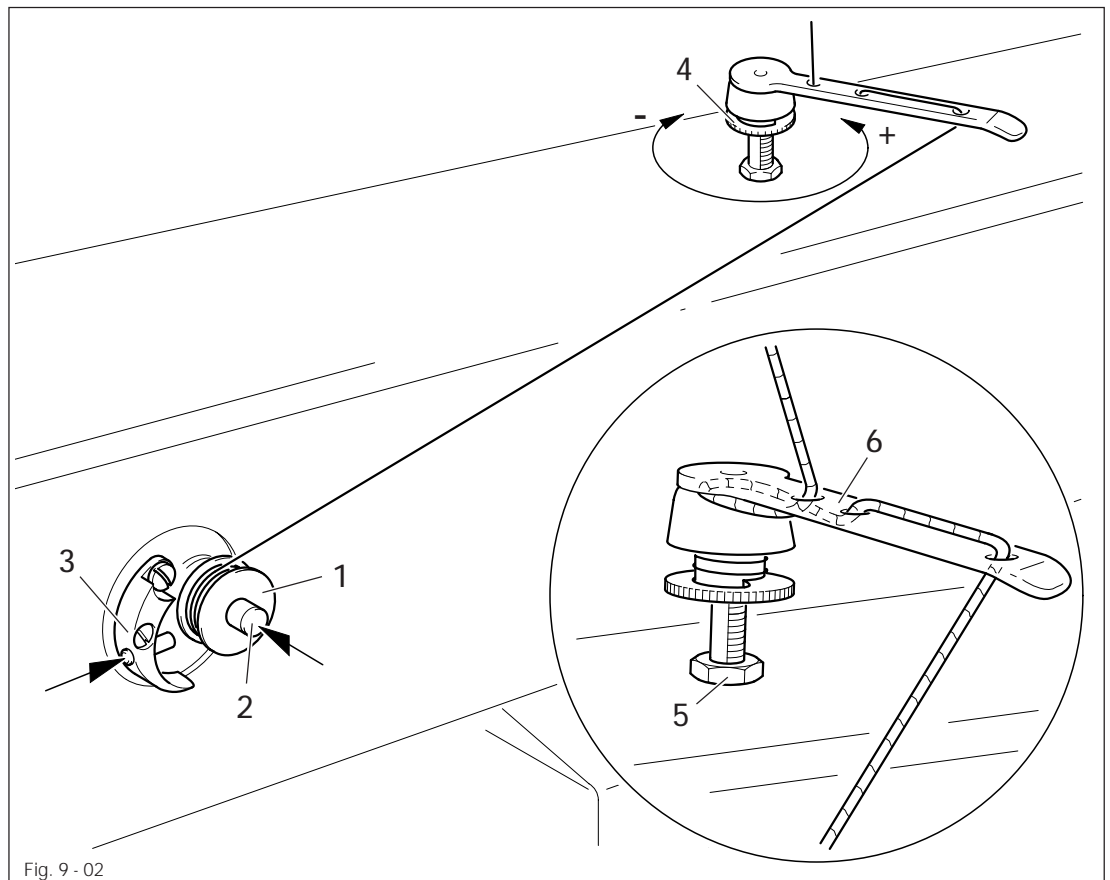

Fig. 9 - 02

- Place an empty bobbin 1 onto bobbin shaft 2.
- Thread the bobbin in accordance with Fig. 9-02 and wind it anti-clockwise around bobbin 1 a few times.
- Switch on the bobbin winder while at the same time pressing bobbin winder spindle 2 and lever 3.



The bobbin fills up during sewing.

- The tension of the thread on bobbin 1 can be adjusted with knurled screw 4.
- The bobbin winder stops automatically when bobbin 1 is full.

If the thread is wound unevenly:

- Loosen nut 5.
- Turn thread guide 6 accordingly.
- Tighten nut 5.

## 9.03

### Removing/Inserting the bobbin case

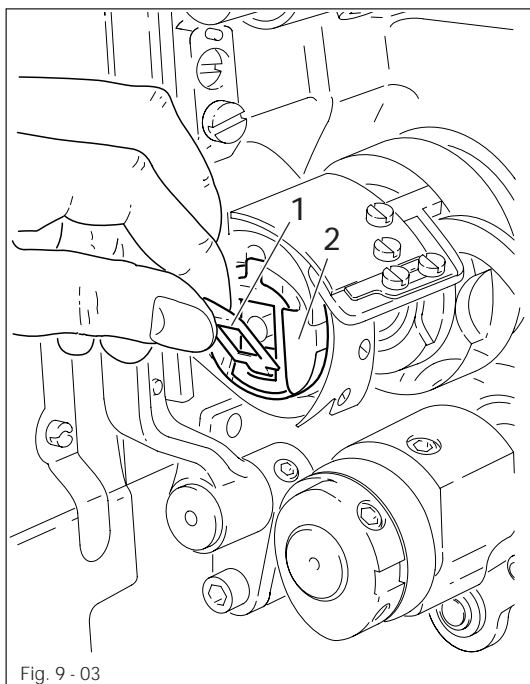

Turn the machine off!  
Danger of injury if machine suddenly starts running!

Removing the bobbin case:

- Tilt back the machine.
- Raise latch 1 and remove bobbin case 2.

Inserting the bobbin case:

- Press bobbin case 2 until you feel it snap into the bobbin case base.



Return the machine to its upright position using **both** hands!  
Danger of injury by crushing between the machine and the table top!

## 9.04

### Inserting the bobbin case / Adjusting the bobbin thread tension

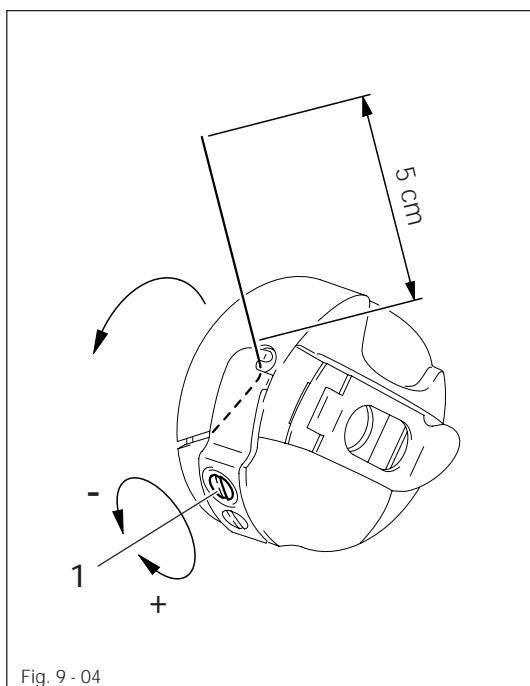

- Insert the bobbin into the bobbin case.
- Pass the thread through the slot under the spring according to Fig. 9-04.
- Pass the thread through the notch.
- Adjust the thread tension by turning screw 1.



When the thread is pulled, the bobbin must rotate in the direction of the arrow.

9.05 Threading the needle thread / Adjusting the needle thread tension

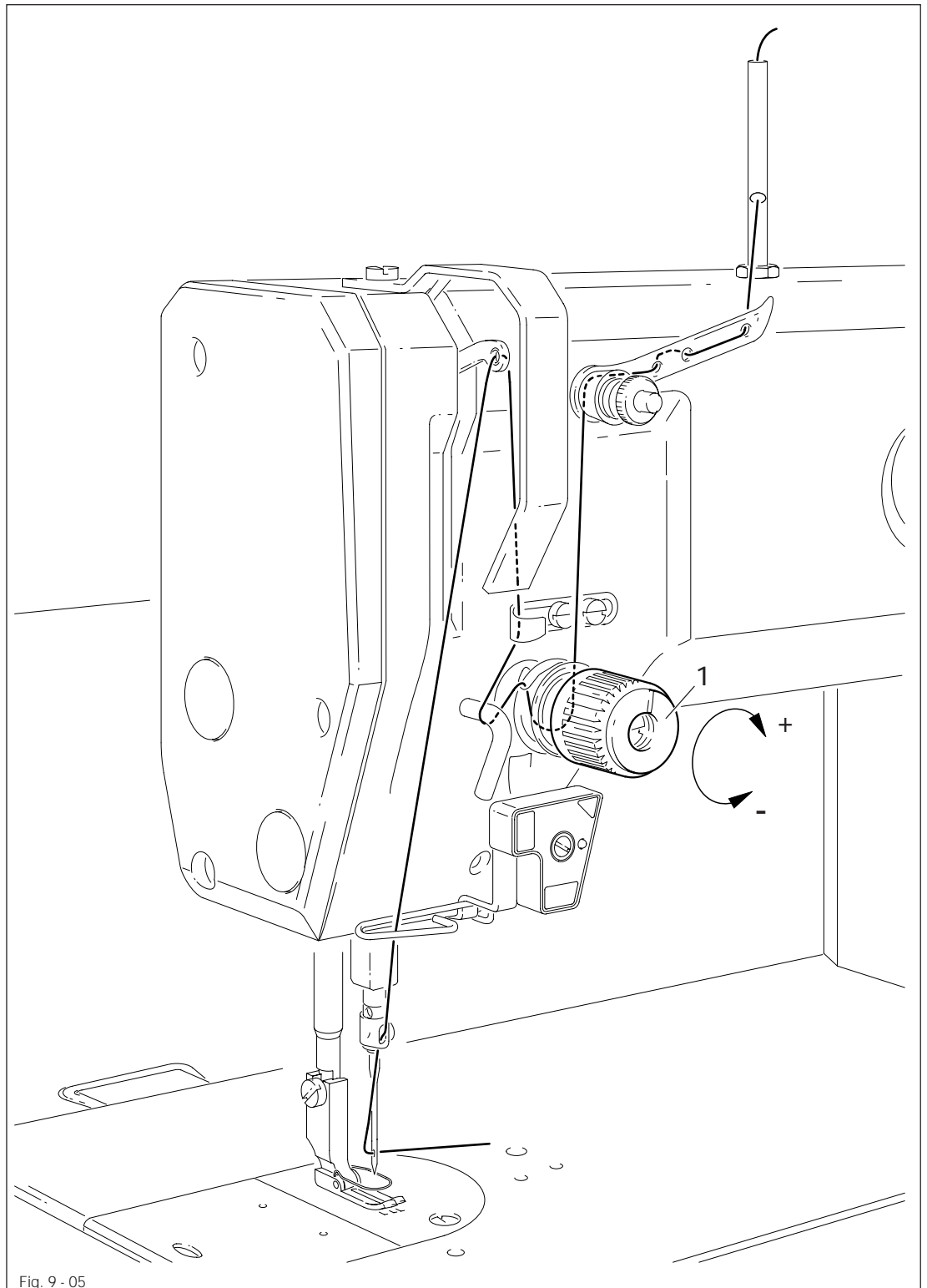

Fig. 9 - 05



Turn the machine off!

- Thread the machine as shown in Fig. 9-05.
- Adjust the needle thread tension by turning disk 1.

## 9.06 Adjusting the stitch length

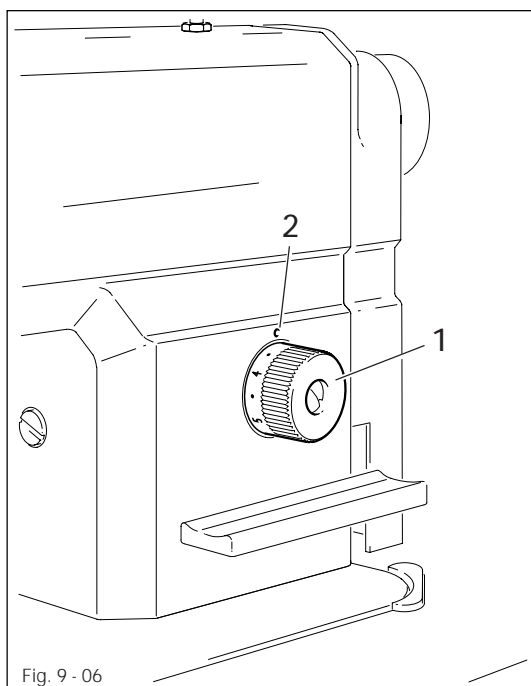

- Apply pressure to disk 1 and turn until the desired stitch length on the indicator scale is aligned with the mark 2.

10 Care and maintenance

Clean .....	daily, more often if in continuous operation
Check oil level .....	annually <sup>▲</sup> , only for the PFAFF 1183



▲ These maintenance intervals are calculated for the average running time of a single shift operation. If the machine is operated more than this, shorter intervals are recommended.

10.01 Cleaning the machine

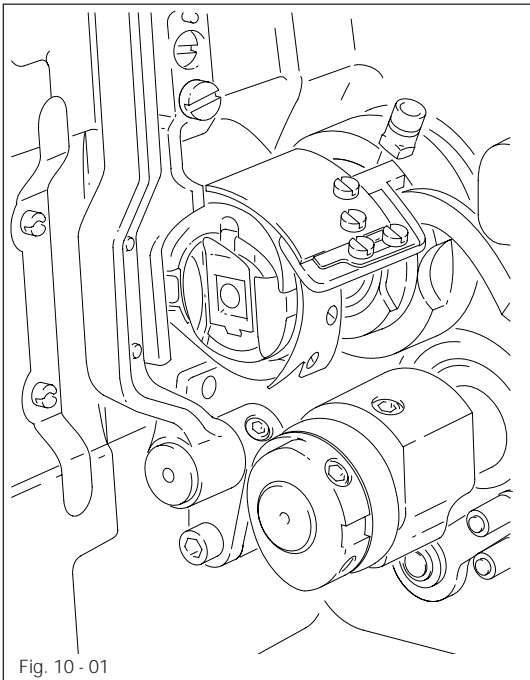

Fig. 10 - 01



Turn off the machine!  
Danger of injury if machine suddenly starts running!

- Tilt back the machine.
- Clean the hook and hook compartment daily, more often if in continuous operation.



Return the machine to its upright position using **both** hands!  
Danger of injury by crushing between the edge of the machine and the table top!

### 10.02 Filling the oil reservoir (PFAFF 1183 only)



The PFAFF 1053 is completely maintenance-free and runs without oil.

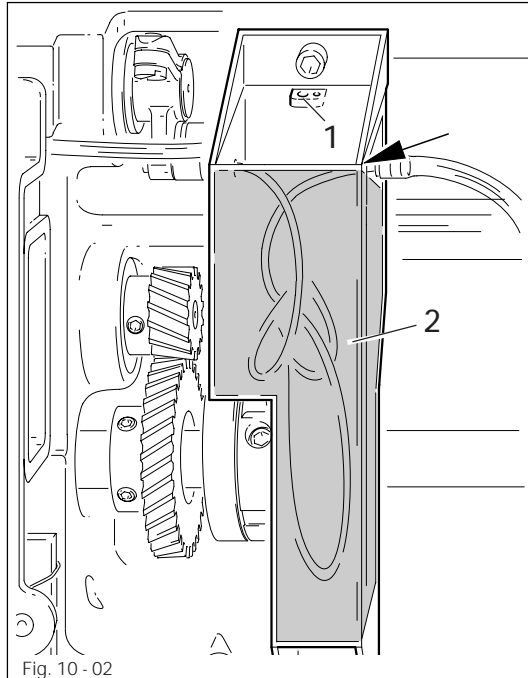

The oil reservoir must always have oil in it.

- Whenever it is necessary to refill the reservoir, tilt back the machine and let it rest on the sewing head support.
- Fill oil through hole 1 into the reservoir 2 up to the level of the front edge (see arrow).



Return the machine to its upright position using **both** hands!

Danger of injury by crushing between the machine and the table top!



Only use oil with a mean viscosity of  $10.0 \text{ mm}^2/\text{s}$  at  $40^\circ\text{C}$  and a density of  $0.847 \text{ g/cm}^3$  at  $15^\circ\text{C}$ .

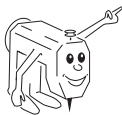

We recommend PFAFF sewing machine oil, part no. 280-1-120 105.

## 11 Adjustment



For the PFAFF 1053 and the PFAFF 1183, an adjustable clamp must not be fastened onto the needle bar!

Otherwise, the special coating on the needle bar could be damaged.

### 11.01 Notes on adjusting

All adjustments in these adjustment instructions are based on a completely installed machine and must only be carried out by appropriately trained specialists. Covers on the machine which sometimes have to be removed and replaced for checks and adjustment work are not mentioned here. The screws and nuts in brackets () are attachments of machine parts which are to be loosened before making the adjustment and tightened again after the adjustment has been carried out.

### 11.02 Tools, gauges and other accessories for adjusting

- 1 set of screwdrivers with blade widths from 2 to 10 mm
- 1 set of wrenches with jaw widths from 7 to 14 mm
- 1 set of Allan keys from 1.5 to 6 mm
- 1 metal rule, (Part No. 08-880 218-00)
- 1 feed dog adjustment gauge, Part No. 61-111 639-71
- 1 adjustment pin (5 mm dia.), Part No. 13-033 346-05
- 1 adjustment gauge for feed motion timing, Part No. 61-111 639-70
- Sewing thread and test material

### 11.03 Abbreviations

TDC = top dead center

BDC = bottom dead center

## 11.04 Checking and adjusting aids



With the help of the adjustment pin 1 (Part No. 13-033 346-05) and the adjustment gauge 3 (Part No. 61-111 639-70), the required positions for the adjustment can be set.

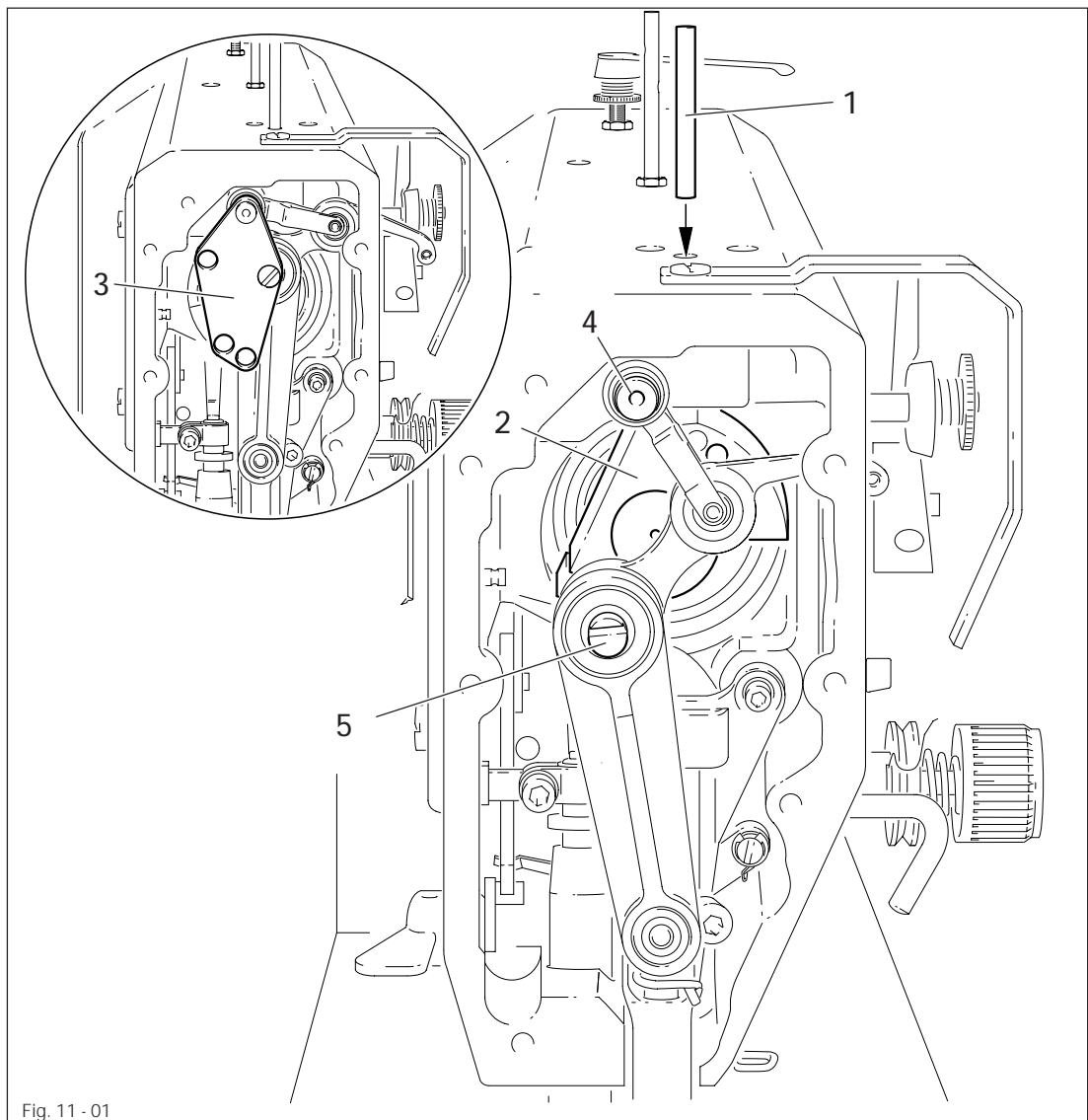
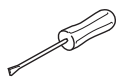

Fig. 11 - 01



Setting the needle bar position **1.8 mm above BDC** (needle rise position):

- Turn handwheel until the needle bar is approx. in the required position.
- Insert the adjustment pin 1 into the hole.
- Move the handwheel back and forth slightly until the adjustment pin 1 engages the crank 2.

Setting the needle bar position **0.6 mm below TDC** (feed motion timing):

- Fit adjustment gauge 3 onto bolts 4 and 5, ensuring that the right side (for 32 or 36 mm needle bar stroke) is used.



## 11.05 Adjusting the basic machine

### 11.05.01 Basic position of the machine drive (for 220 V built-in motors only)

#### Requirement

When the needle bar position is 0.6 mm above the BDC, the marks on the machine housing 1 and toothed belt wheel 4 must be flush with each other.

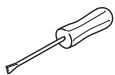
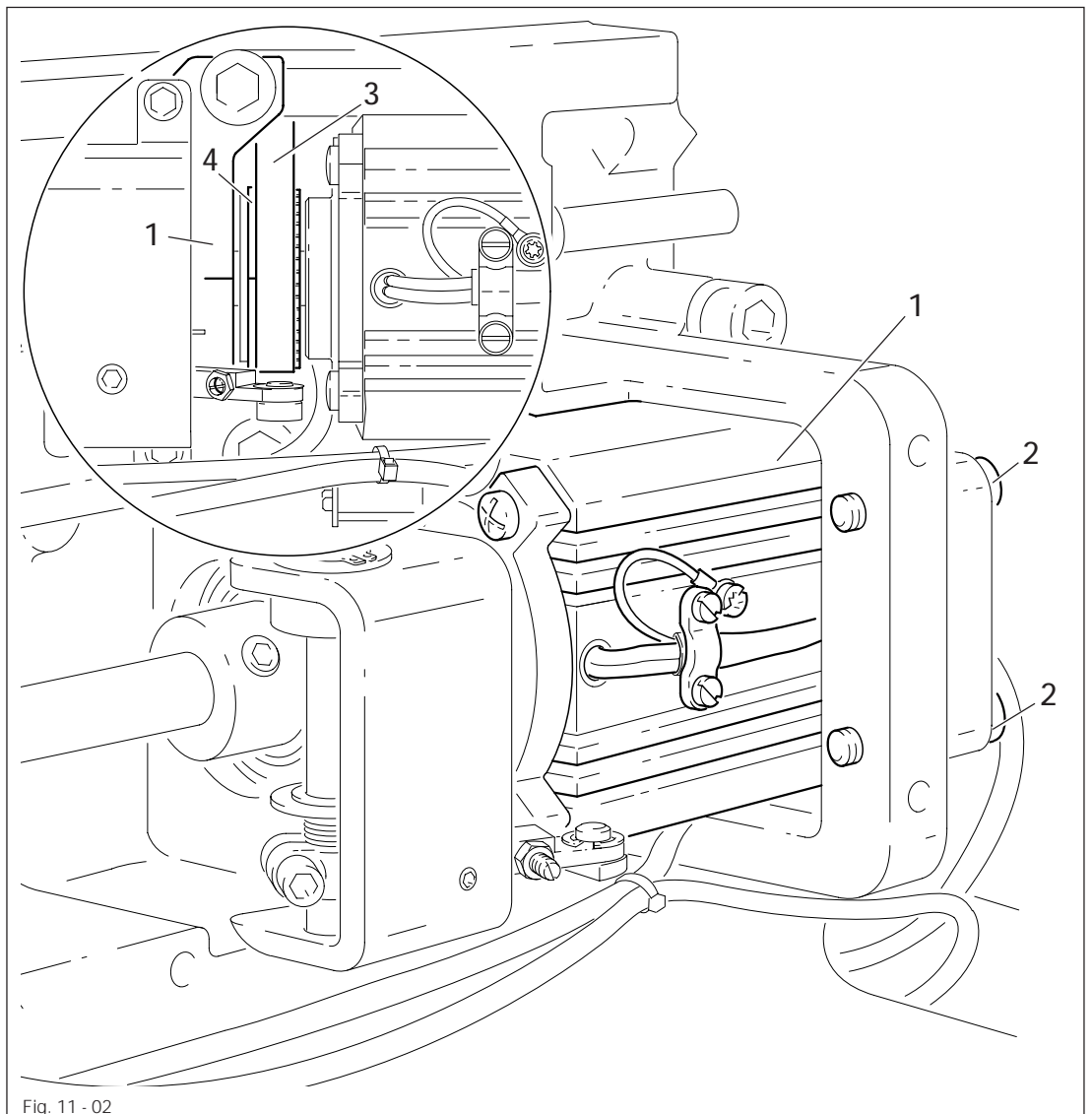

- Using the adjustment gauge, position the needle bar 0.6 mm above BDC.
- Disassemble motor 1 (screws 2).
- Remove toothed belt 3 from toothed belt wheel 4.
- Turn toothed belt wheel 4 according to the requirement and slide the toothed belt on to the wheel.
- Screw on motor 1, making sure that the motor clutch can only be placed on the toothed belt wheel in one particular position. (The segments have varying sizes).

## Adjustment

### 11.05.02 Preadjusting the needle height

#### Requirement

When the needle bar is positioned 1.8 mm above BDC, the mark on the needle bar 1 must be flush with the bottom edge of the needle bar frame 3.

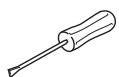
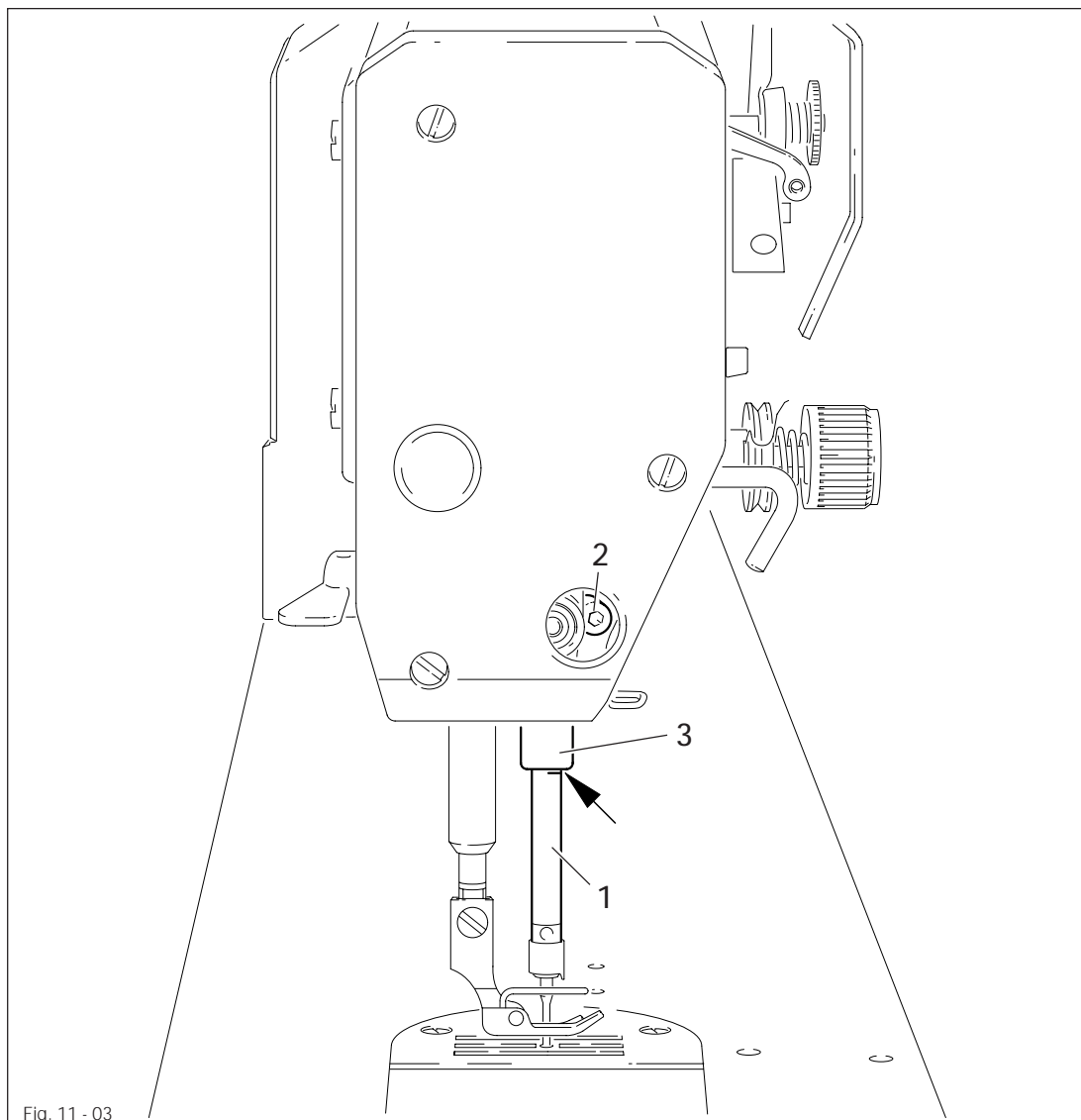

- Using the adjustment pin, position the needle bar 1.8 mm above BDC.
- Move needle bar 1 (screw 2), without turning it, according to the requirement.

## 11.05.03 Neutralizing the feed dog movement

### Requirement

At a stitch length setting of "0", cranks 1 and 3 must be flush with each other, and the feed dog must not carry out any driving motion when the handwheel is turned.

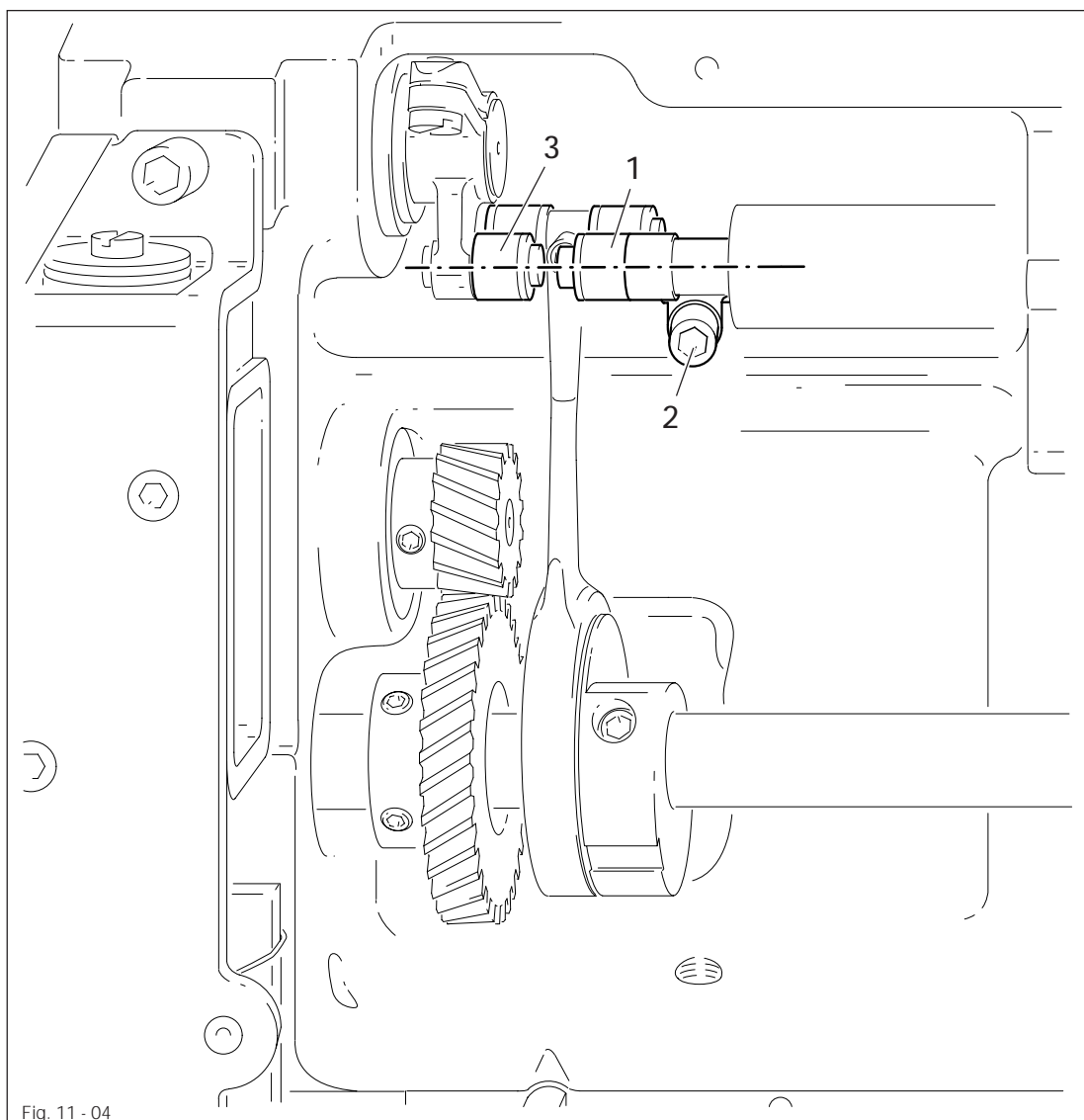
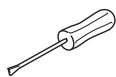

Fig. 11 - 04



- Raise the presser foot and set the stitch length to "0".
- Turn crank 1 (screw 2) according to the requirement.

## 11.05.04 Feed lifting motion

### Requirement

At stitch length setting "0" and needle bar position TDC,

1. the feed dog must be at its upper reversal point
2. the control cam 3 must be resting against the feed lifting eccentric 1 and
3. the surface of control cam 3 must be parallel to the bedplate.

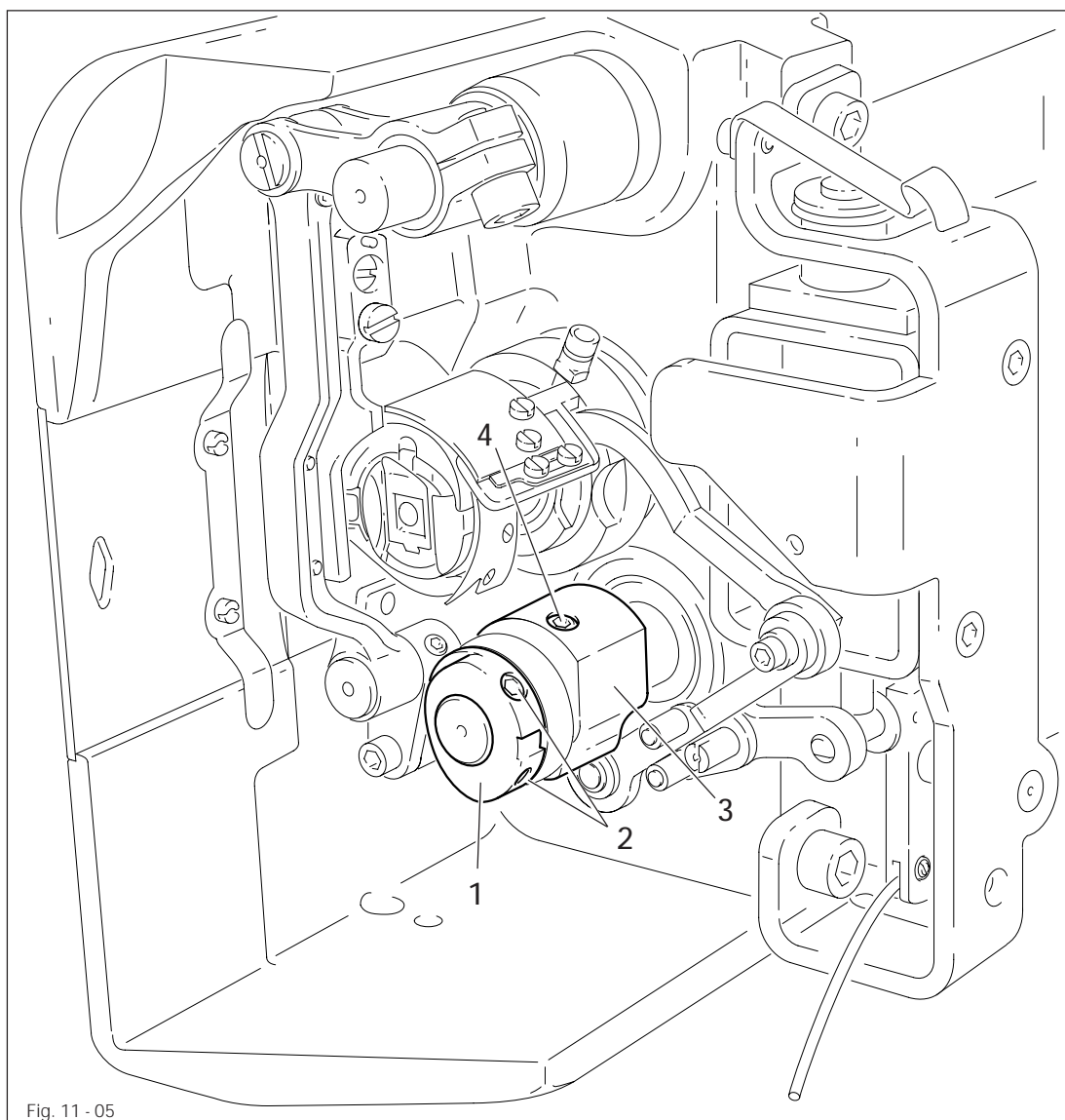
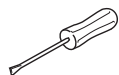

Fig. 11 - 05



- Set stitch length to "0" and position the needle bar at its TDC.
- Turn eccentric 1 (screw 2) according to requirement 1.
- Turn control cam 3 (screws 4) according to requirement 2.



For machines without the thread trimming devices -900/22 or -900/24, the control cam 3 serves as a balance weight.

Fig. 11-05 illustrates a machine with a thread trimmer which has been mounted.

## 11.05.05 Feed dog height

**Requirement**

At stitch length setting "0" and needle bar position TDC, the feed dog 7 must,

1. viewed from the side and in the direction of feed, be positioned at the center of the needle plate cutout, as well as
2. rest against the feed dog adjustment gauge 1 along its entire length.

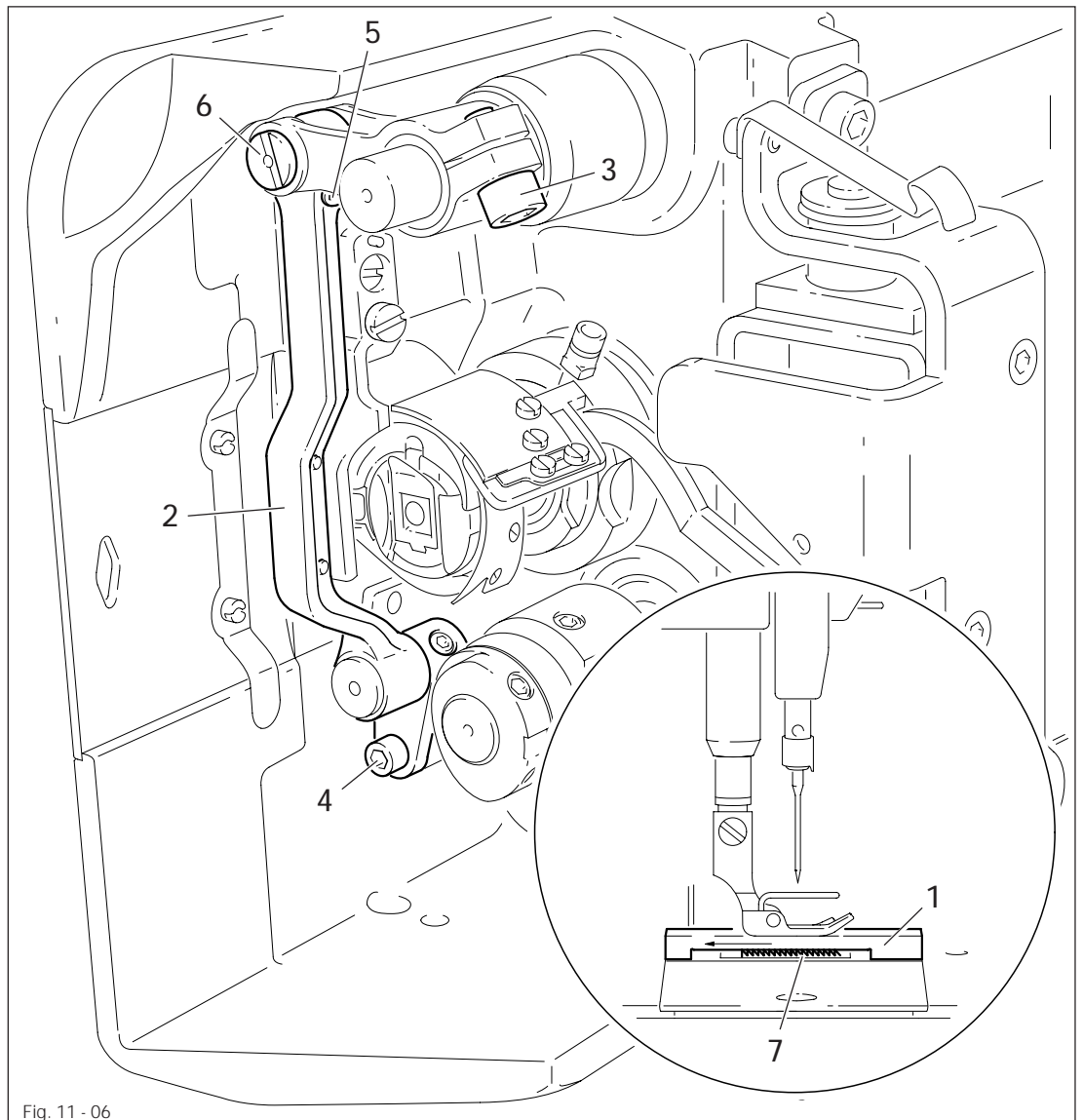
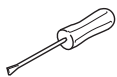

Fig. 11 - 06



- Set stitch length to "0" and position the needle bar at its TDC.
- Raise the presser foot.
- Position the feed dog adjustment gauge 1, with the arrow in the direction of sewing and the front edge even with the needle plate edge, over the needle plate cutout and allow the presser foot to touch it lightly.
- Adjust feed dog carrier 2 (screw 3) according to requirement 1.
- Loosen screws 4 and 5.
- Adjust feed dog carrier 2 and/or eccentric 6 according to requirement 2.
- Tighten screws 4 and 5.

## 11.05.06 Feed dog motion

### Requirement

At needle bar position 0.6 mm below TDC, when the stitch length setting is at its largest, the feed dog must not carry out any movement when the reverse-feed control **3** is operated.

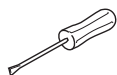
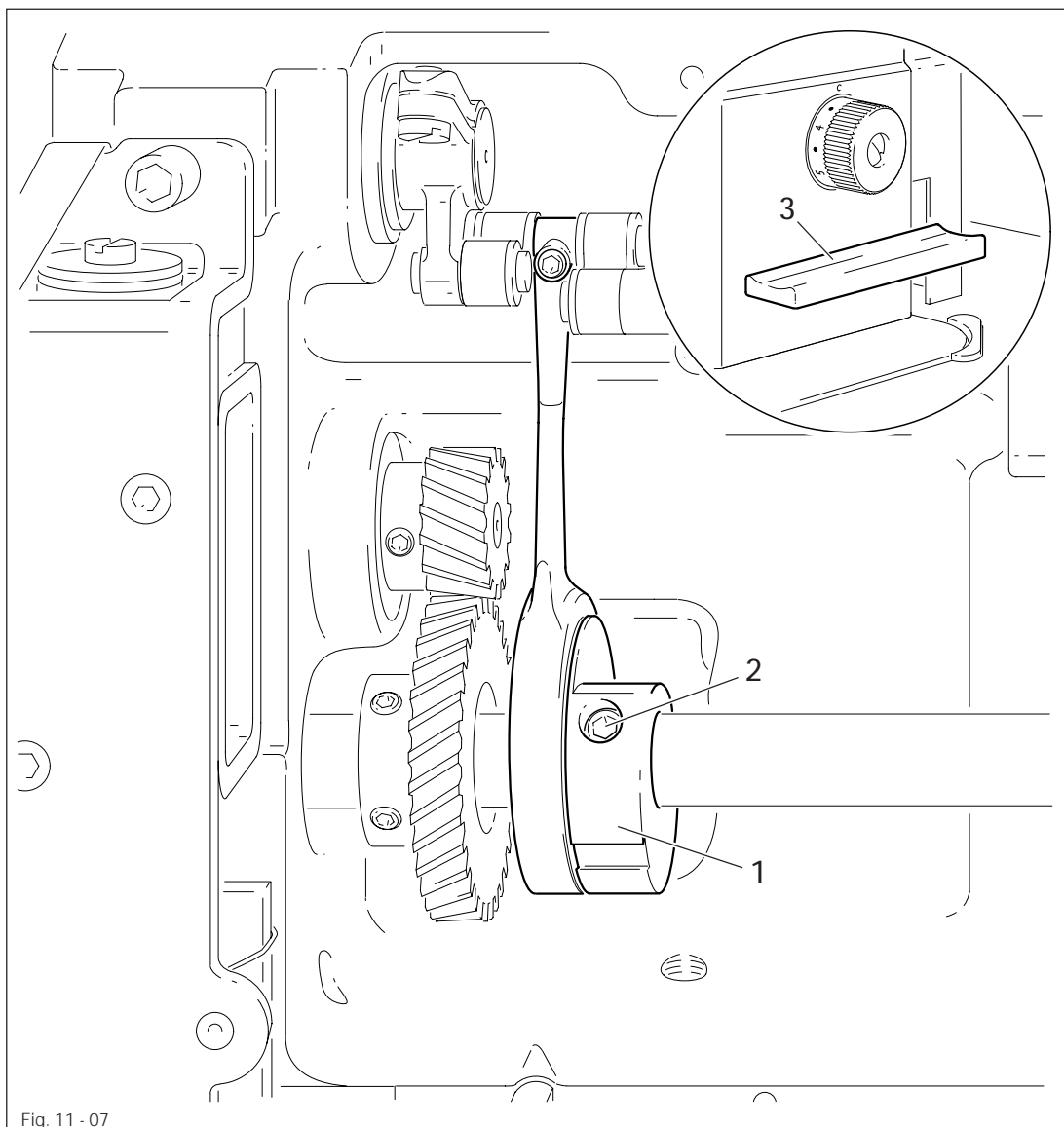

- Set stitch length to the largest setting.
- Using the adjustment gauge, set the needle bar at a position 0.6 mm below its TDC.
- Turn eccentric **1**, without moving it laterally, according to the requirement.

## 11.05.07 Needle in needle hole center

**Requirement**

The needle must penetrate the needle hole exactly in the middle.

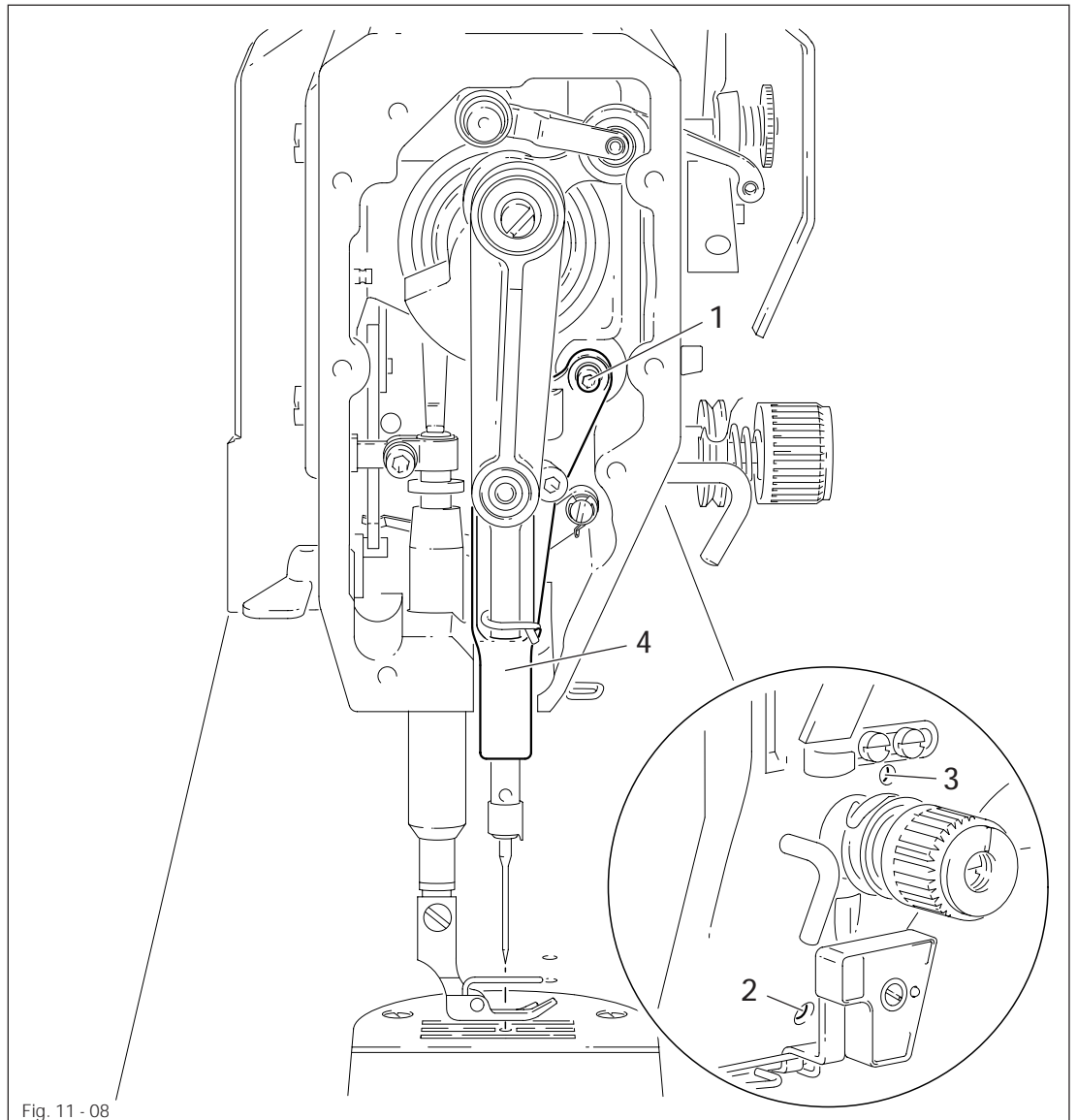
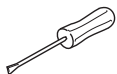

Fig. 11 - 08



- Position the needle directly over the needle hole.
- Loosen screws 1, 2 and 3.
- Move the needle bar frame 4 according to the **requirement**.
- Tighten screw 2 and turn screw 3 slightly.
- Via screw 1, bring the retracted guide bolt to the eye of the needle bar frame 4 and tighten it.
- Turn the handwheel a few times to prevent distortion to the needle bar frame 4.
- Tighten screw 3.

### Requirement

1. The front edge of the hook shaft **6** must be at a distance of **14.5 mm** to the needle center. At the same time, the slot in the hook shaft bearing **1** (see arrow) must be parallel to the bedplate and pointing opposite to the direction of sewing.
2. There must be a slight amount of play between the gears **3** and **5**.

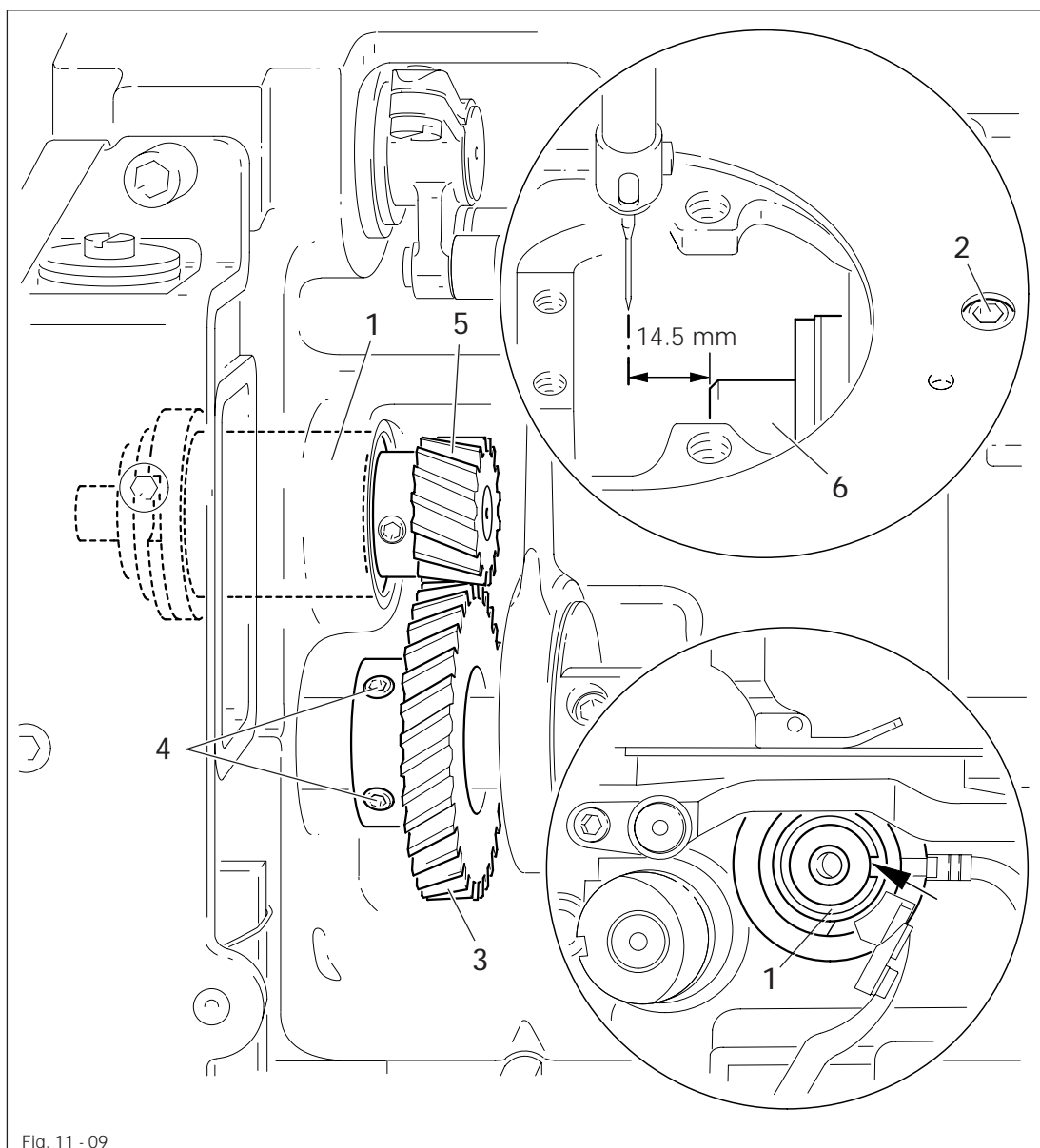
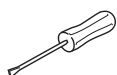

Fig. 11 - 09



- Align hook shaft bearing **1** (screw **2**) according to requirement 1.
- Slide gear **3** (screws **4**) on to the shaft according to requirement 2.



## 11.05.09 Hook lubrication (for PFAFF 1183 only)

### Requirement

1. The centrifugal disk 1 must be positioned 1.5 mm in front of the oil ring 3.
2. When the machine is running at full speed, after approx. 10 seconds a mark should be made by a fine stripe of oil on the strip of paper placed over the needle plate cutout.

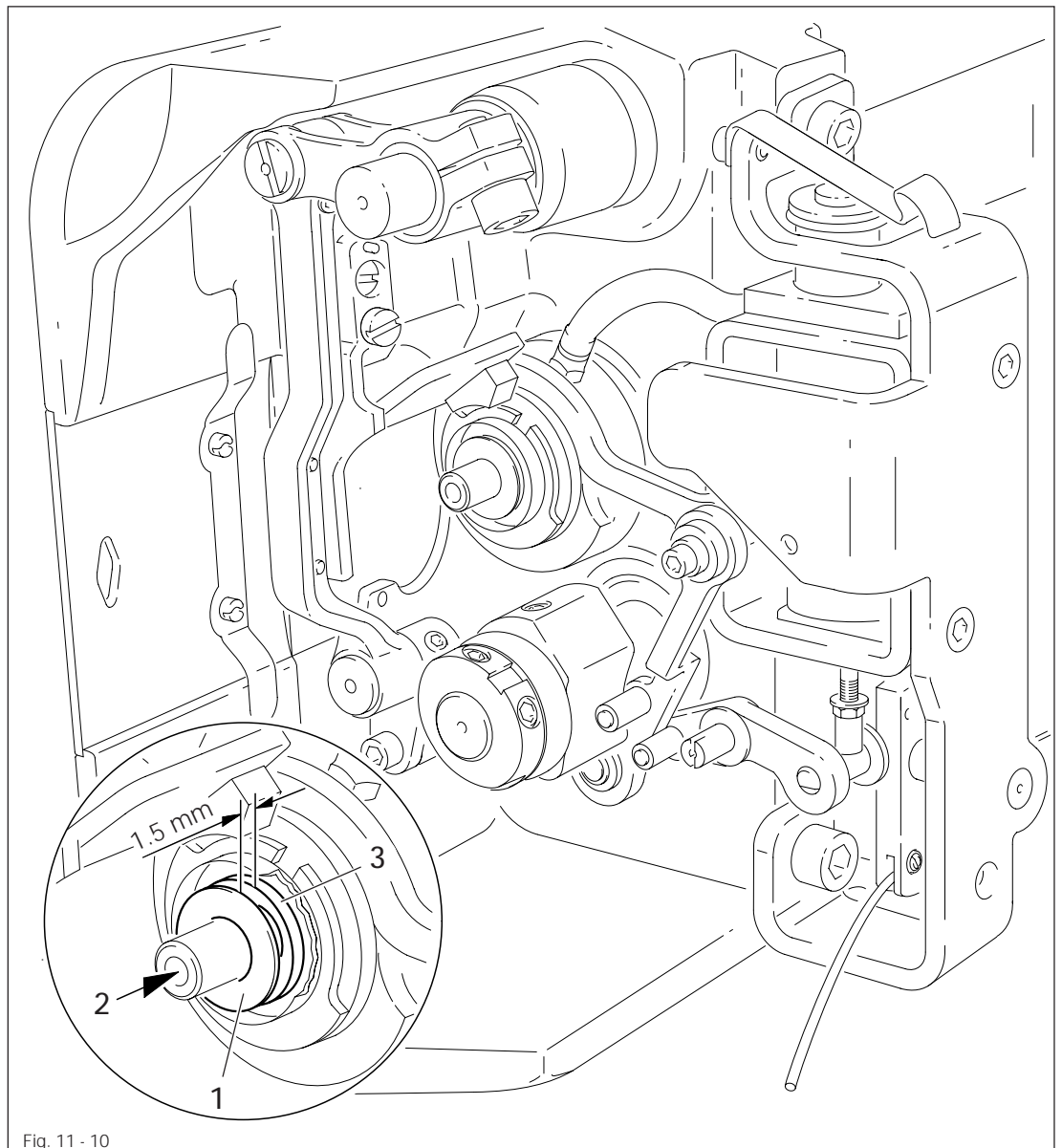
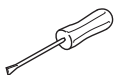

Fig. 11 - 10



The adjustment is only necessary if the wick has been replaced.  
When replacing the wick, make sure that the new wick is impregnated with oil.



- Move the centrifugal disk 1 (screw 2) according to requirement 1.
- Check requirement 2. If necessary, move centrifugal disk 1.

## Requirement

With the needle at 1.8 mm after BDC,

1. the hook point 6 must point to the middle of the needle and be at a distance of 0.05 mm - 0.1 mm to the clearance cut of the needle, and
2. the top edge of the needle eye must be 0.8 mm below the hook point.
3. Between the projection of the bobbin case position finger 4 and the bottom of the retaining groove there should be a distance of 0.5 mm.

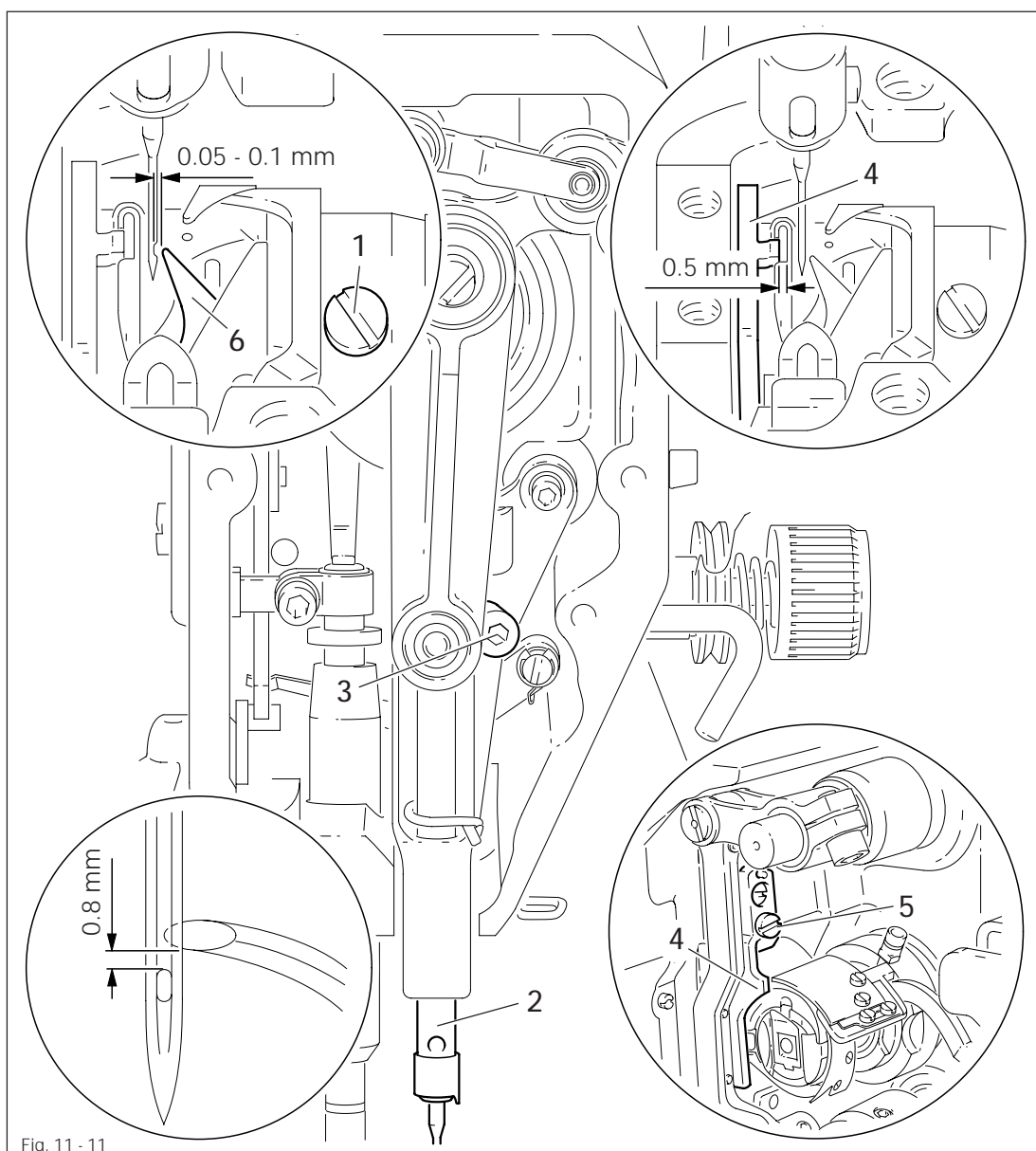
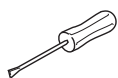

Fig. 11 - 11



- Using the adjustment pin, position the needle bar at 1.8 mm after BDC.
- Adjust the hook according to requirement 1.
- Tighten screw 1.
- Move needle bar 2 (screw 3) without turning it according to requirement 2.
- Align bobbin case position finger 4 (screw 5) according to requirement 3.

## 11.05.11 Thread tension release (machines without -900/...)

### Requirement

With hand lever 1 raised, the distance between the tension discs 4 must be at least 0.5 mm.

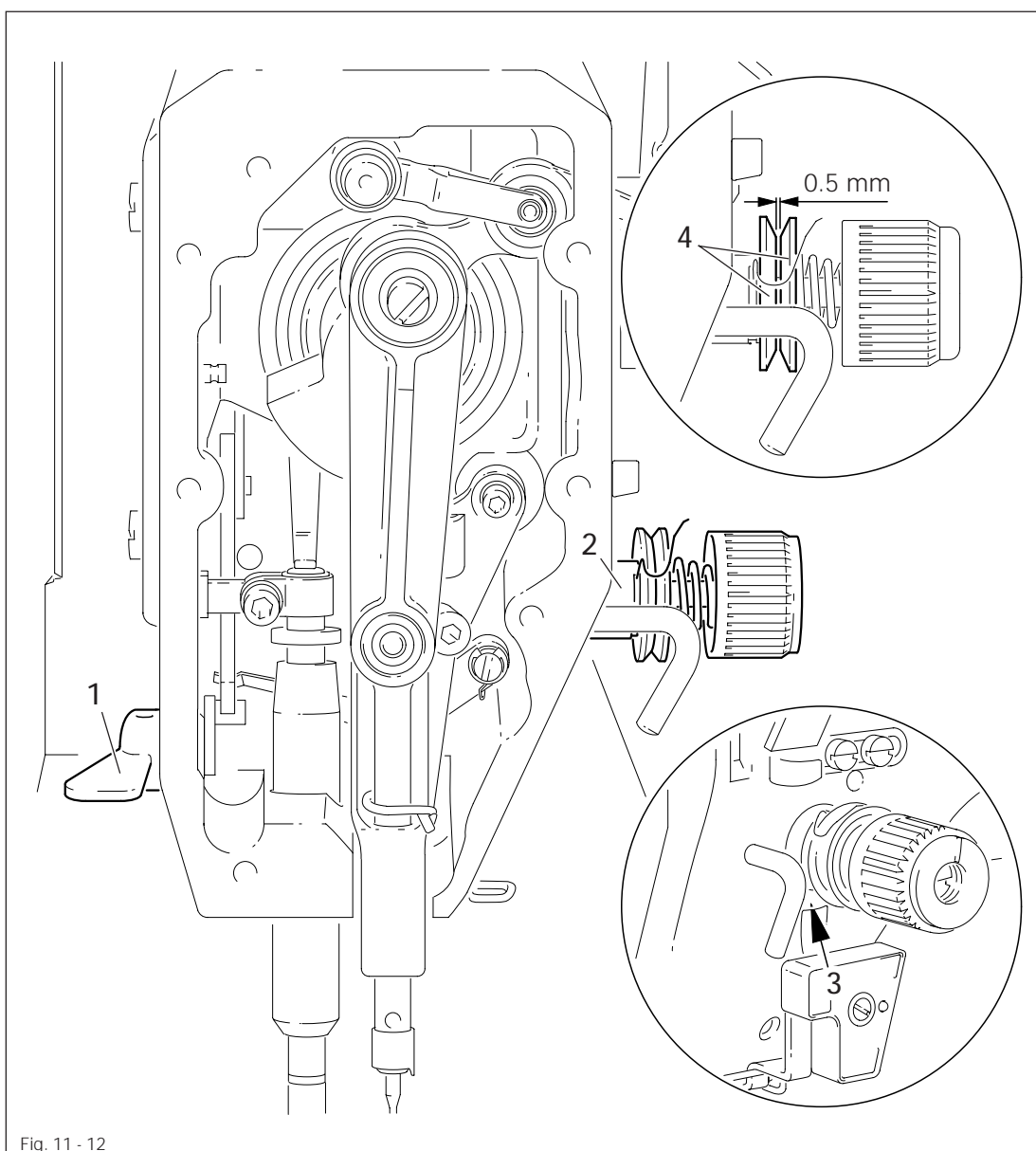
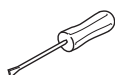

Fig. 11 - 12



- Raise hand lever
- Move thread tension 2 (screw 3) according to the requirement.

## 11.05.12 Thread check spring and slack thread regulator

### Requirement

1. The motion of the thread check spring must be completed when the needle point enters the material (spring stroke approx. **7 mm**).
2. When the thread loop is at its largest when going around the hook, the thread check spring must have moved by approx. **1 mm**.

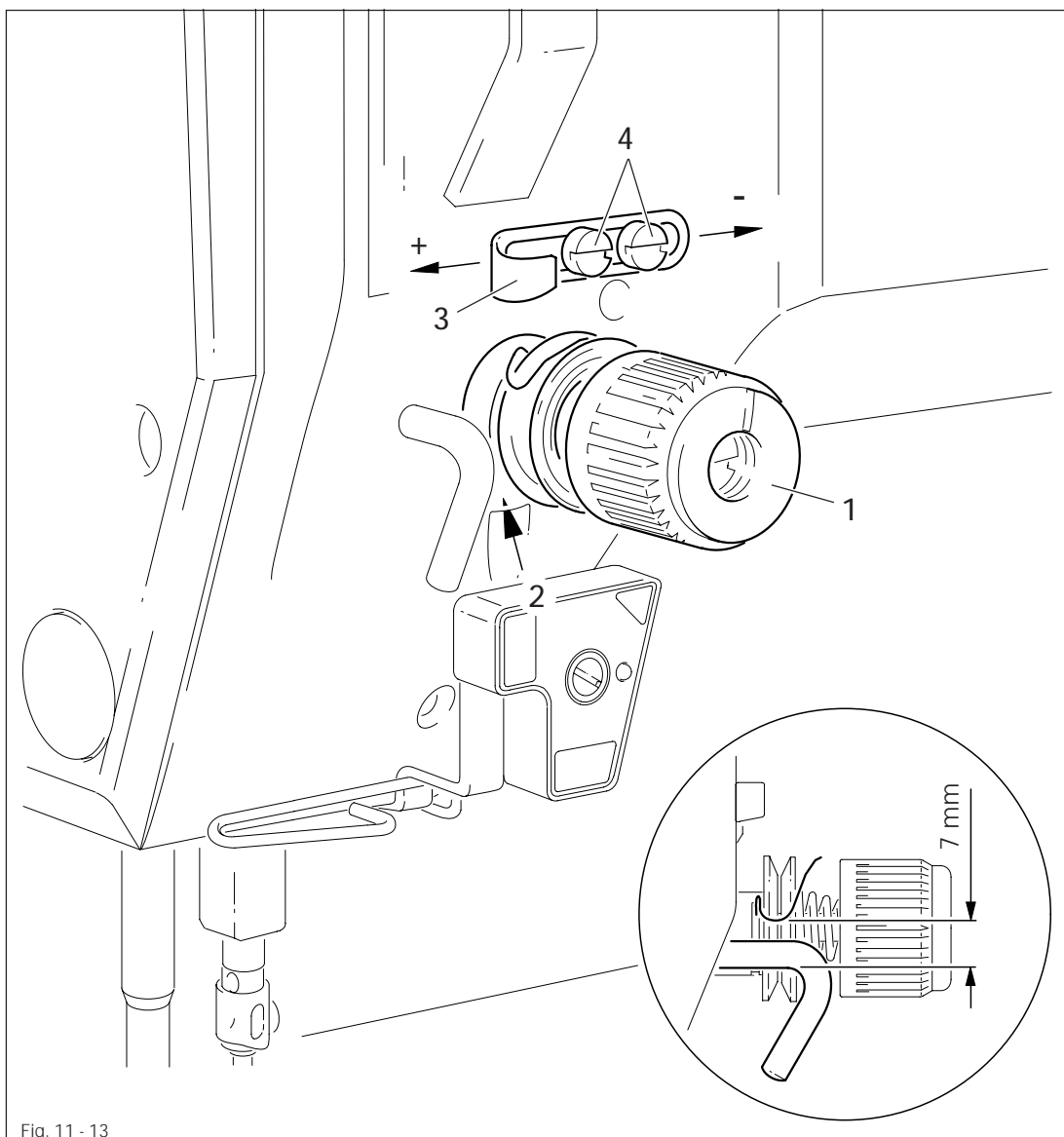
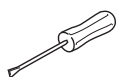

Fig. 11 - 13



- Turn thread tension **1** (screw **2**) according to **requirement 1**.
- Refer back to **chapter 11.05.11 Thread tension release** and check. If necessary, carry out adjustment.
- Move slack thread regulator **3** (screws **4**) according to **requirement 2**.



Due to technical sewing reasons it may be necessary to deviate from the spring stroke indicated above.

Move the slack thread regulator **3** (screw **4**) toward the "+" (= more thread) or toward the "-" (= less thread)

## 11.05.13 Position of knee lever

**Requirement**

1. When the knee lever is in its resting position, the axle 5 must be parallel to the bedplate.
2. When the presser foot is resting on the needle plate, the presser bar lifting lever 6 must be touching the circlip 8 lightly and be at a distance of approx. 1 mm from lifting piece 7.

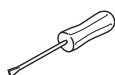
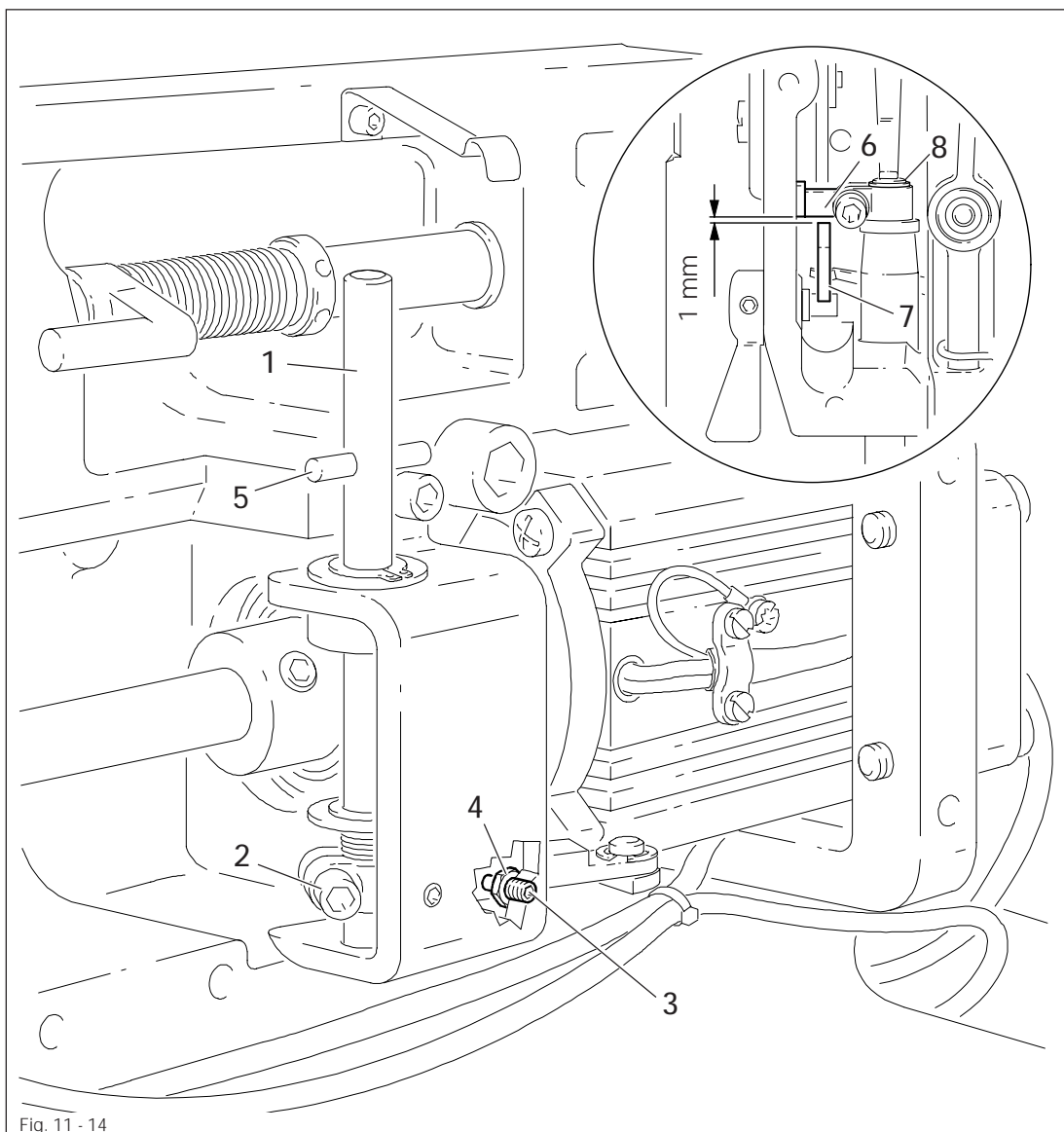

- Turn shaft 1 (screw 2) according to requirement 1.
- Position needle bar at its BDC and allow the presser foot to rest on the needle plate.
- Turn screw 3 (nut 4) according to requirement 2.

## 11.05.14 Knee lever stop

### Requirement

When the knee lever is fully actuated,

1. the presser foot must be raised approx. **9 mm** (or approx. **13 mm** for a large needle bar stroke) above the needle plate, and
2. lever **3** must swing down automatically.

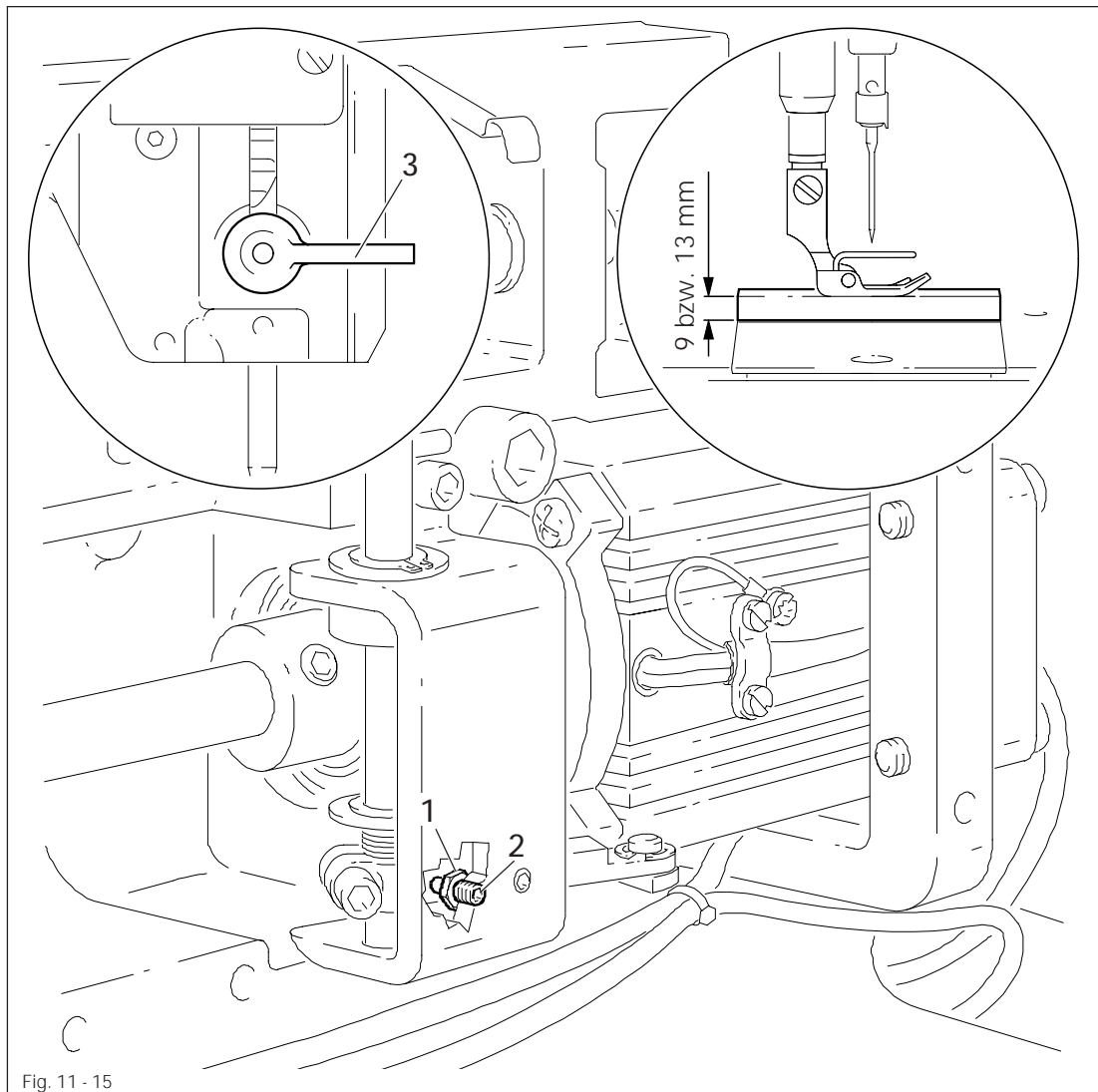
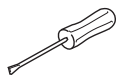

Fig. 11 - 15



- Loosen nut **1** and unscrew screw **2** a few turns.
- Raise the presser foot and slide a **9 mm** (for small needle bar stroke) or **13 mm** (for large needle bar stroke) thick spacer under the presser foot.
- Swing down lever **3**
- Move the knee lever until it is fully actuated. The presser foot must remain on the spacer.
- Now turn screw **2** as far as it will go.
- Turn screw **2** a half turn back and tighten nut **1**.

## 11.05.15 Spuler

**Requirement**

1. With the bobbin winder on, the drive wheel 1 must engage reliably.
2. With the bobbin winder off, the friction wheel 5 must not be driven by the drive wheel 1.
3. The bobbin winder must turn off automatically when the thread level is approx. 1 mm from the edge of the bobbin.

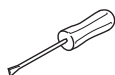
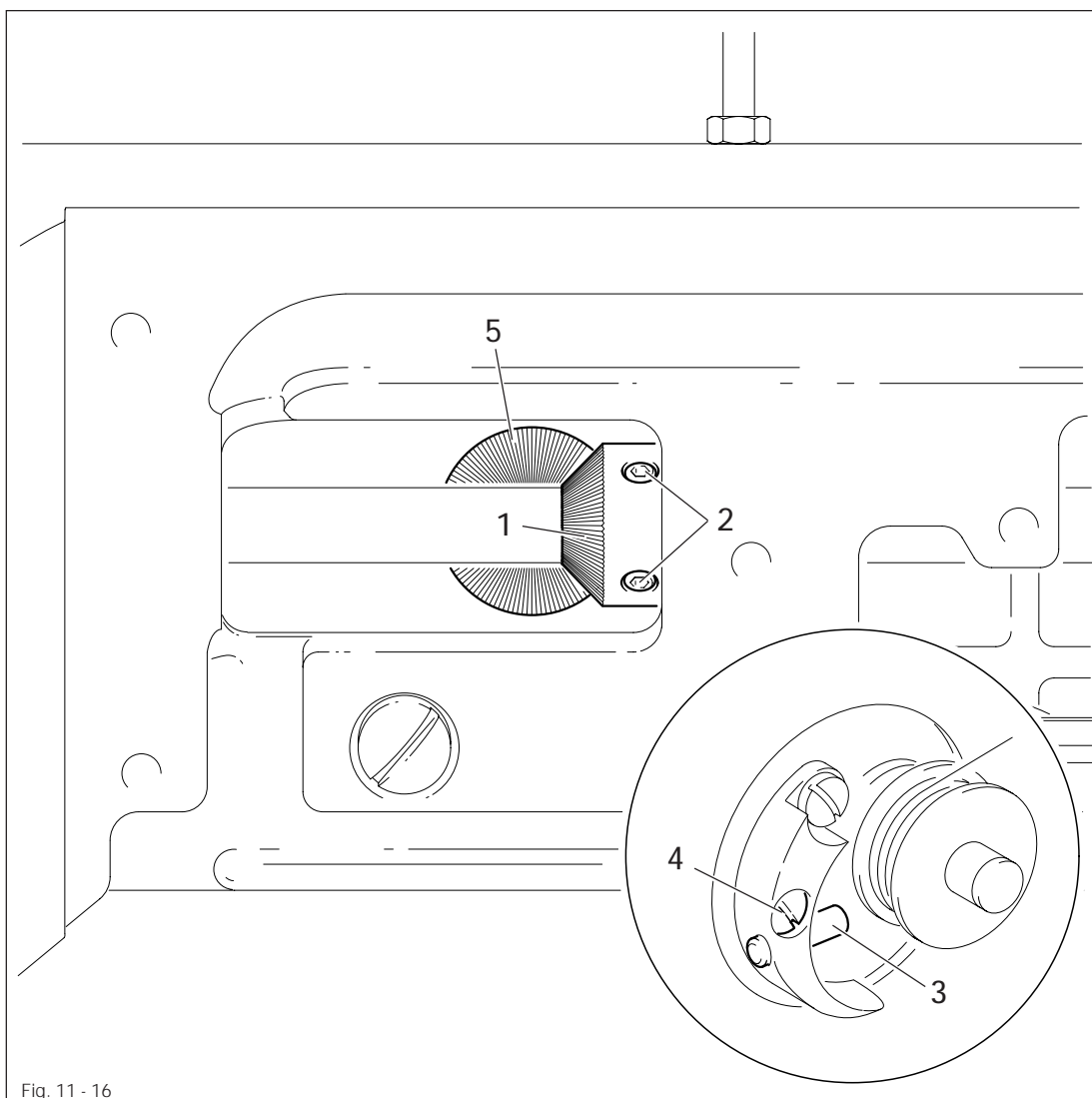

- Move drive wheel 1 (screws 2) in accordance with requirement 1 and 2.
- Move bolt 3 (screw 4) in accordance with requirement 3.

## 11.05.16 Limiting the stitch length



The maximum stitch length which can be selected can be limited mechanically.

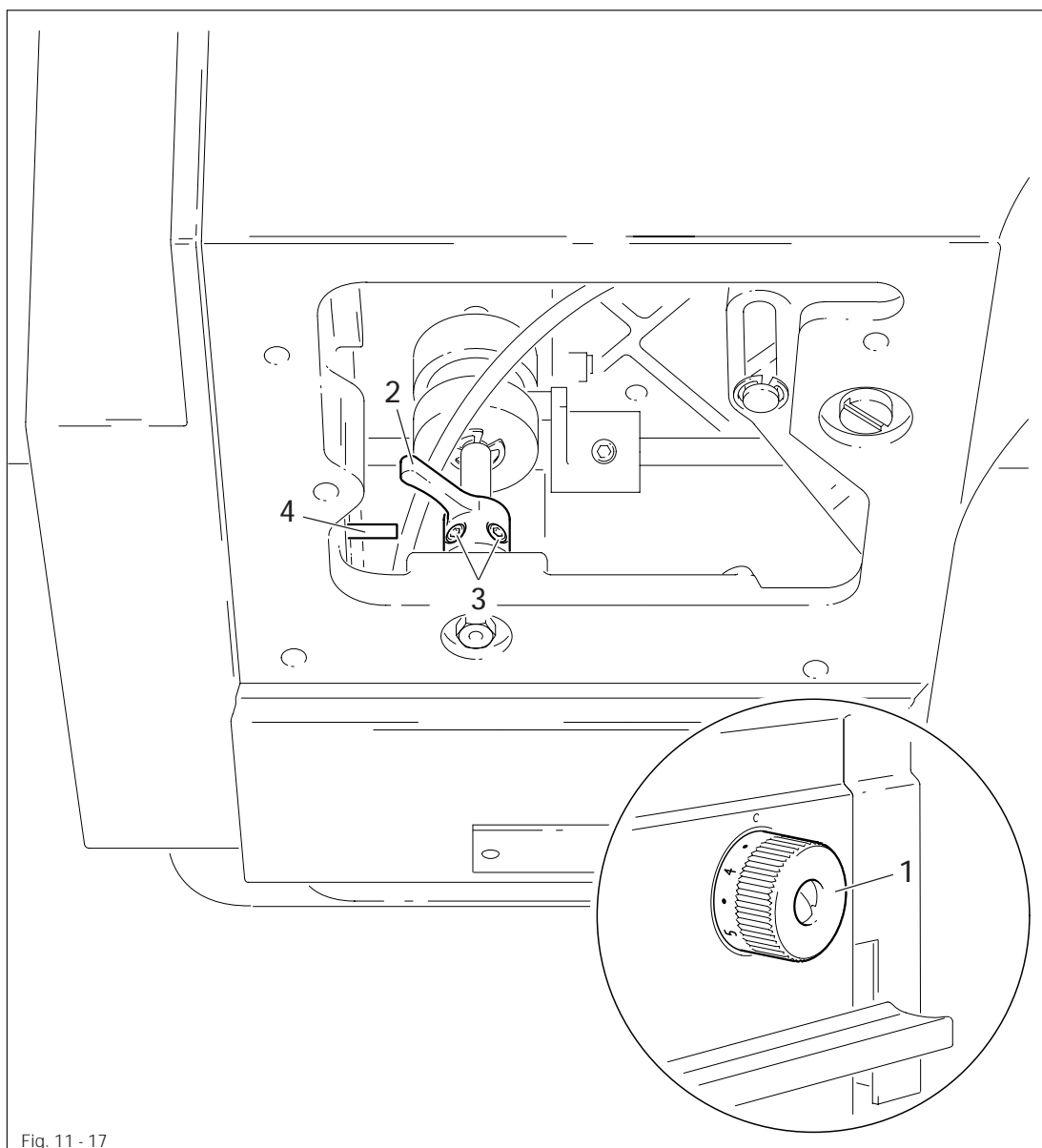

For the subclass -8/31, the maximum stitch length which can be selected must not be above 4.5 mm!

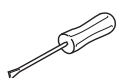

- Set the desired maximum stitch length with regulator disk 1.
- Move crank 2 (screws 3) down against stop 4.



## 11.05.17 Presser foot pressure

### Requirement

The material must be fed reliably. In the process, pressure marks on the material must not be made.

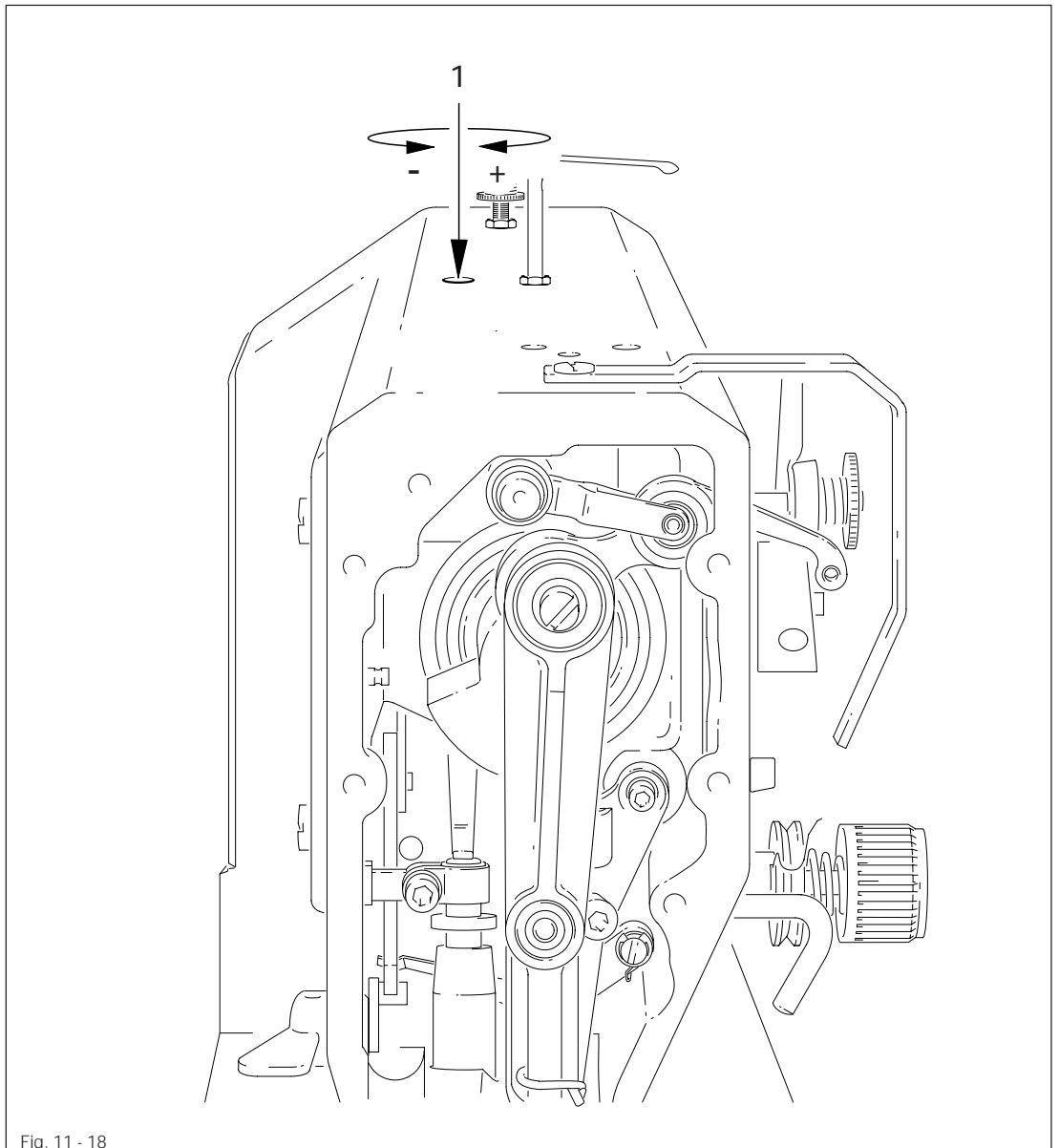
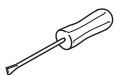

Fig. 11 - 18



- Turn screw 1 in accordance with the **requirement**.

## 11.05.18 Modifying the needle bar stroke



The needle bar stroke is preset in the factory according to requirement. The needle bar stroke can be modified later if specific operating conditions make it necessary to do so.

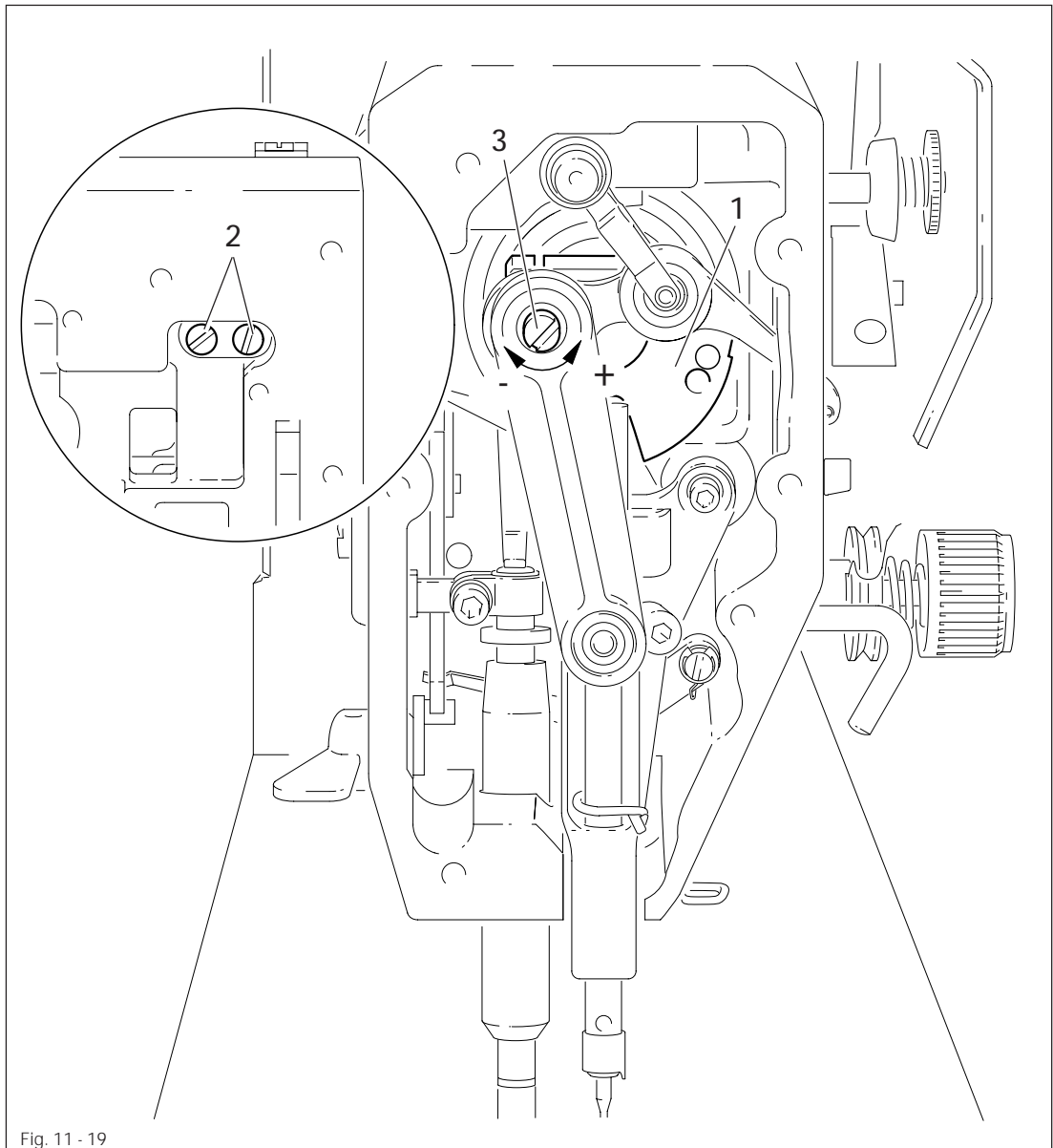
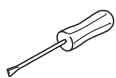

Fig. 11 - 19



After the needle bar stroke has been modified, make sure to readjust the needle height!



- Via the hand wheel, turn crank 1 until the screws 2 can be accessed from the side opening of the housing.
- Turn eccentric 3 (screws 2) as far as possible toward "+" (= large needle bar stroke) or toward "-" (= small needle bar stroke).
- Adjust needle height (see chapter 11.05.02 Preadjusting the needle height and/or chapter 11.05.10 Needle rise, hook-to-needle clearance, needle height and bobbin case position finger).

## 11.06 Adjusting the thread trimmers -900/22 and -900/24

## 11.06.01 Magnet setting

**Requirement**

1. The distance between the bottom edge of the plunger and the top edge of the washer 5 must be **96 mm**.
2. When the thread trimmer is in resting position (magnet retracted), the roller lever 6 must rest against bolt 7 and be at a distance of approx. **0.1 mm** from roller 8.

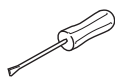
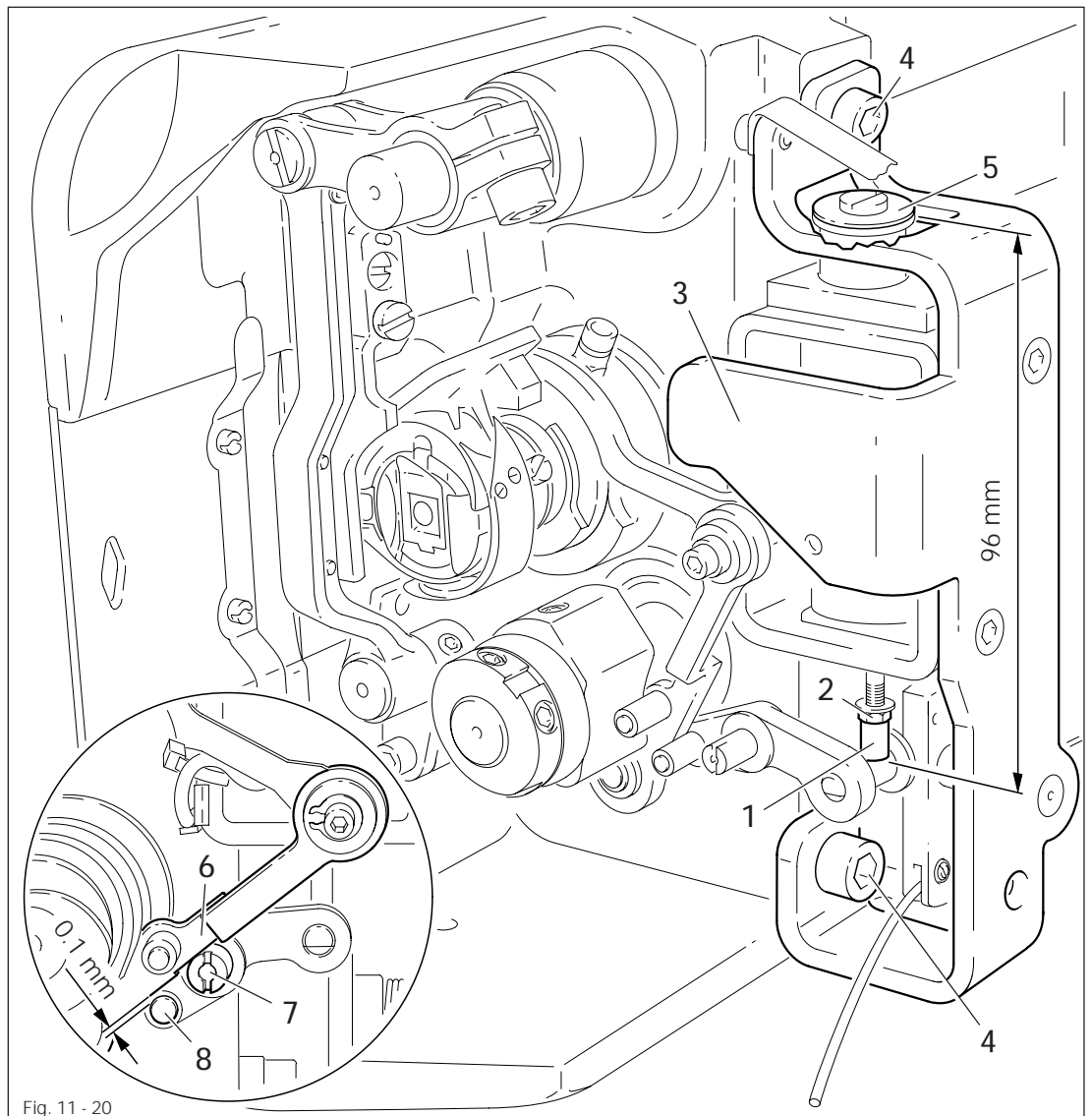

- Turn plunger 1 (nut 2) according to requirement 1.
- Bring thread trimmer into resting position.
- Move magnet holder 3 (screws 4) according to requirement 2.

## 11.06.02 Lateral alignment of the thread catcher

### Requirement

1. The tip of the thread catcher 5 must point exactly to the center of the needle.
2. The thread catcher 5 must be horizontal. It must not graze anything when it is operating.

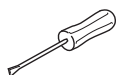
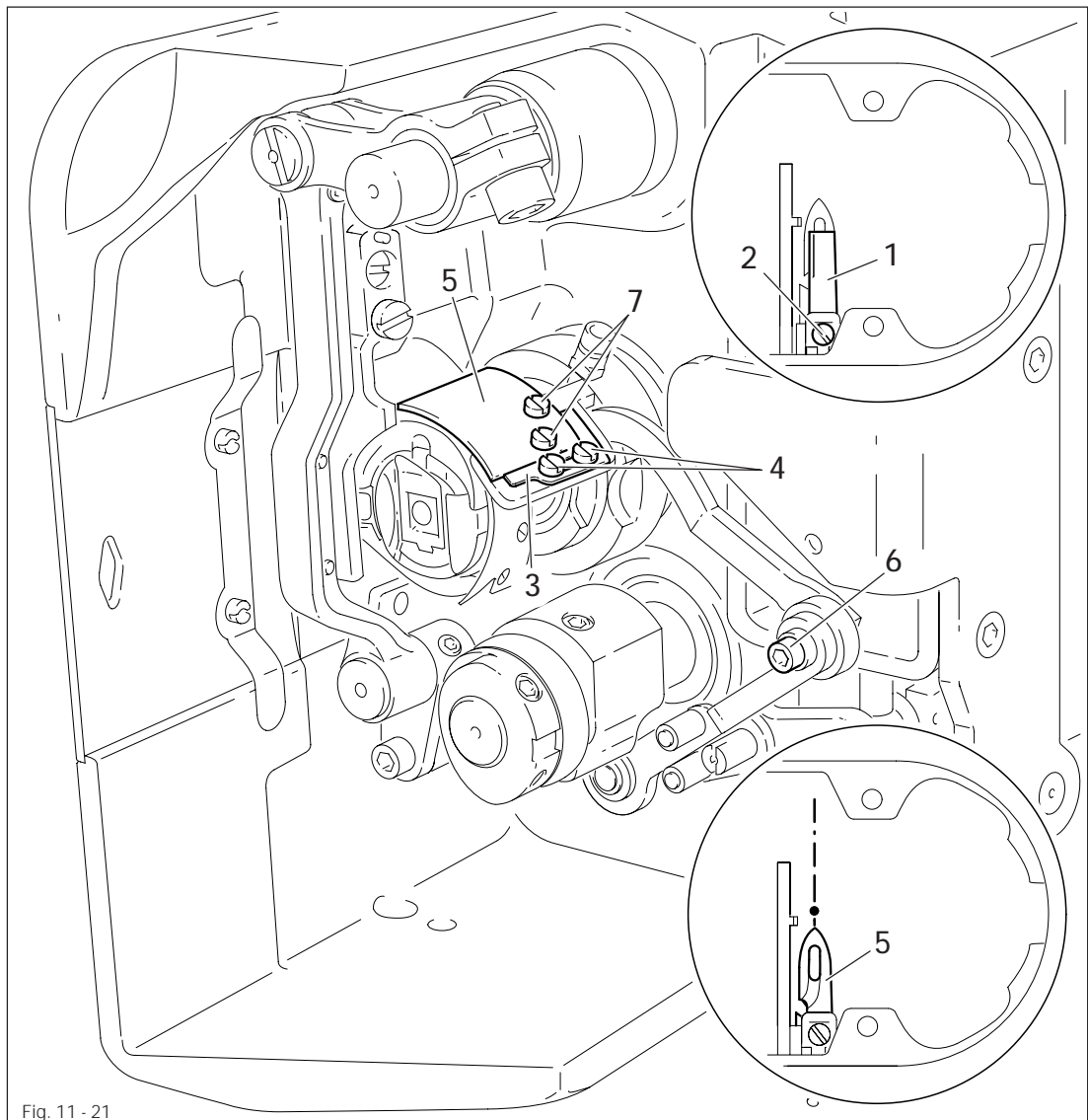

- Remove knife 1 (screw 2).
- Move needle bar to its BDC.
- Loosen stop 3 (screws 4).
- Position thread catcher 5 (screw 6) manually in front of the needle.
- Align thread catcher 5 (screws 7) according to the requirements.



For further adjustments, knife 1 remains dismantled and stop 3 loosened.

## 11.06.03 Knife position

**Requirement**

1. There must be a distance of **4 mm** between the cutting edge of the knife and the needle.
2. The right edge of the knife **1** must not extend beyond the right edge of the thread catcher (see arrow).

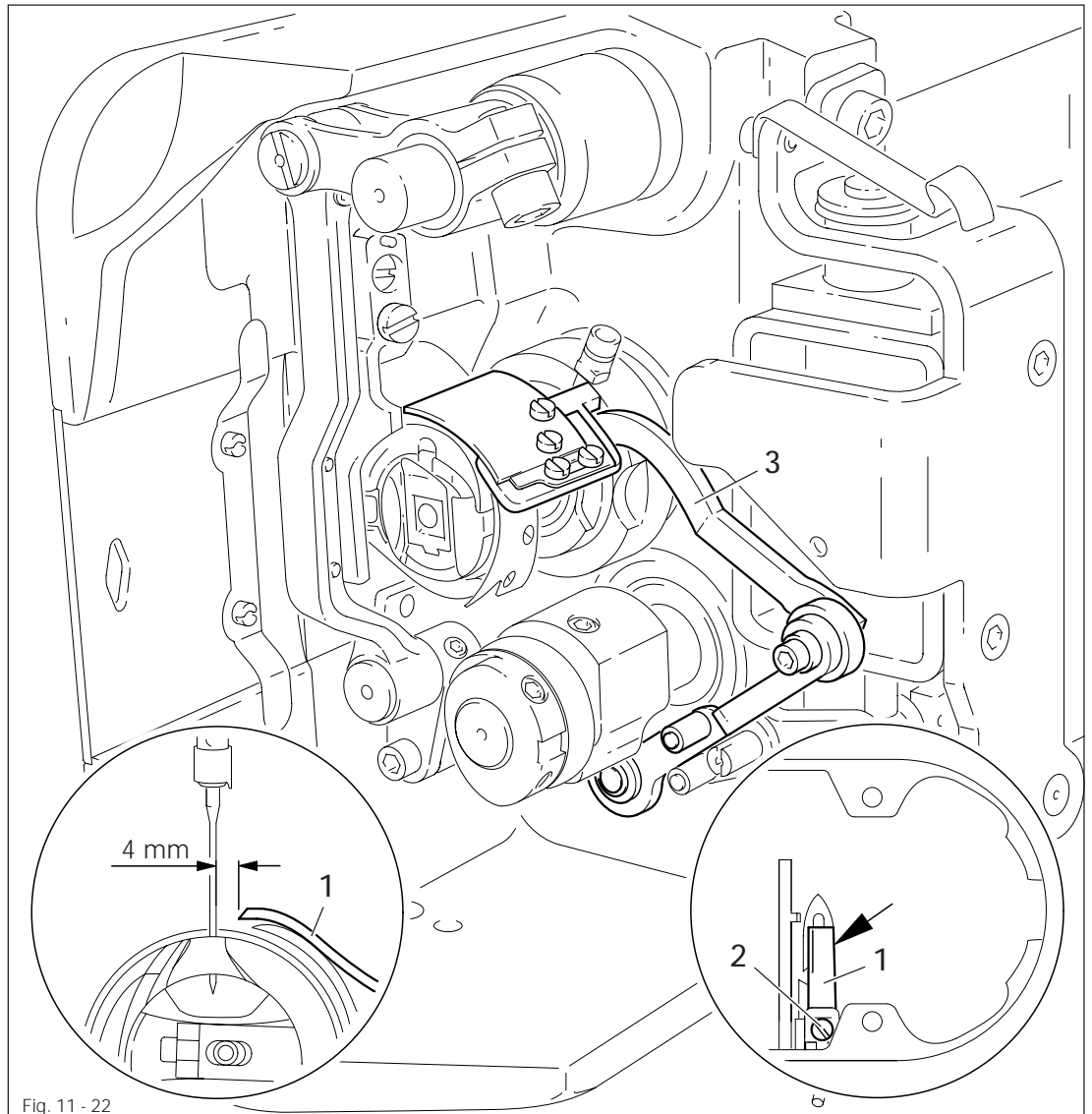
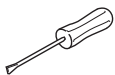

Fig. 11 - 22



- Bring the needle bar to BDC.
- Slide knife **1** under the locking tab and align according to **requirement 1**.
- Tighten screw **2** lightly.
- Adjust thread catcher carrier **3** by hand until the wedge point in the thread catcher is positioned just in front of the cutting edge of the knife.
- Align knife **1** according to **requirement 2** and tighten screw **2**.

## 11.06.04 Front point of reversal of the thread catcher

### Requirement

When the thread catcher 5 is at its front point of reversal, the rear edge of the thread catcher cutout must be positioned 1 mm before the bobbin case position finger 6.

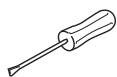
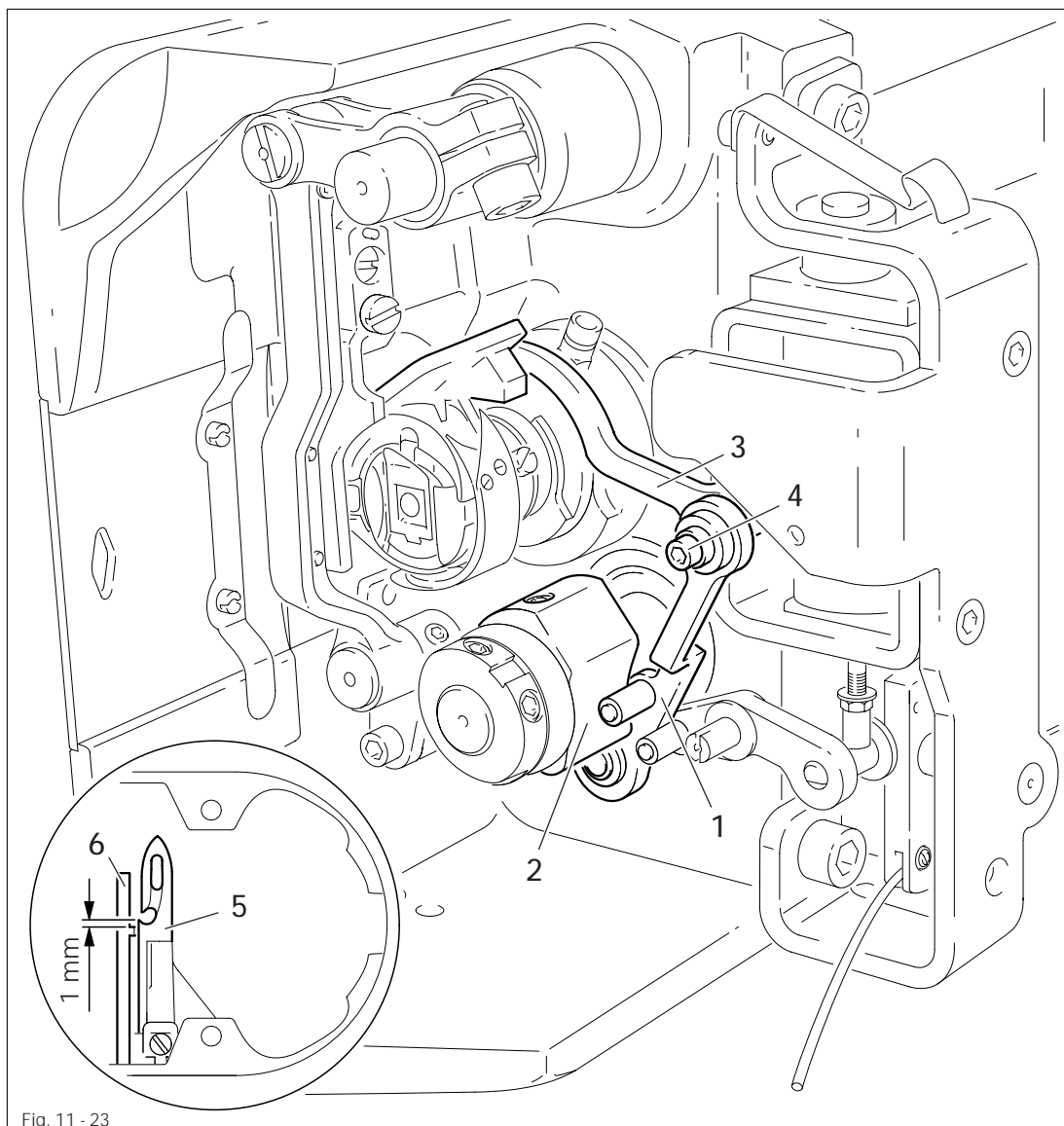

- Swing roller level 1 into the lowest point of the control cam 2.
- Move thread catcher carrier 3 (screw 4) according to the requirement.

## 11.06.05 Manual trimming check

**Requirement**

Two threads must be cut perfectly both left and right in the cutout of thread catcher 1.

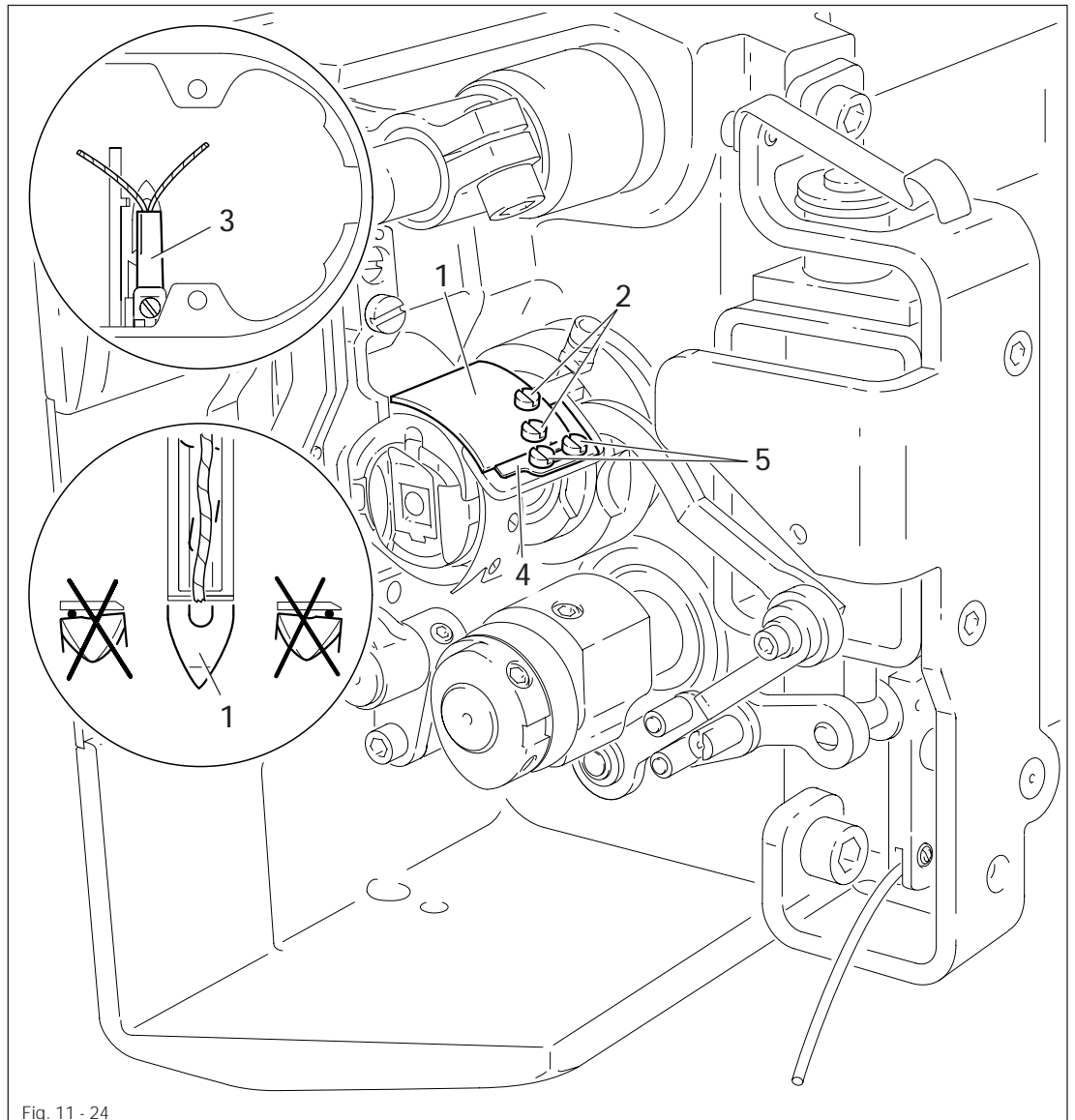
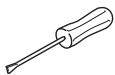

Fig. 11 - 24



- Move thread catcher 1 by hand to its front point of reversal.
- Double the thread and insert into catcher cutout.
- Carry out trimming operation manually.
- If the threads are not cut according to the **requirement**, align thread catcher 1 (screws 2) with knife 3 accordingly.
- Move stop 4 against thread catcher 1 and tighten screws 5.
- Check chapter 11.06.02 **Lateral alignment of the thread catcher**, and readjust if necessary.

## 11.06.06 Thread tension release

### Requirement

When the release olive 3 is resting on the highest point of the cam 4, the distance between the tension disks 7 must be at least 0.5 mm.

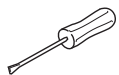
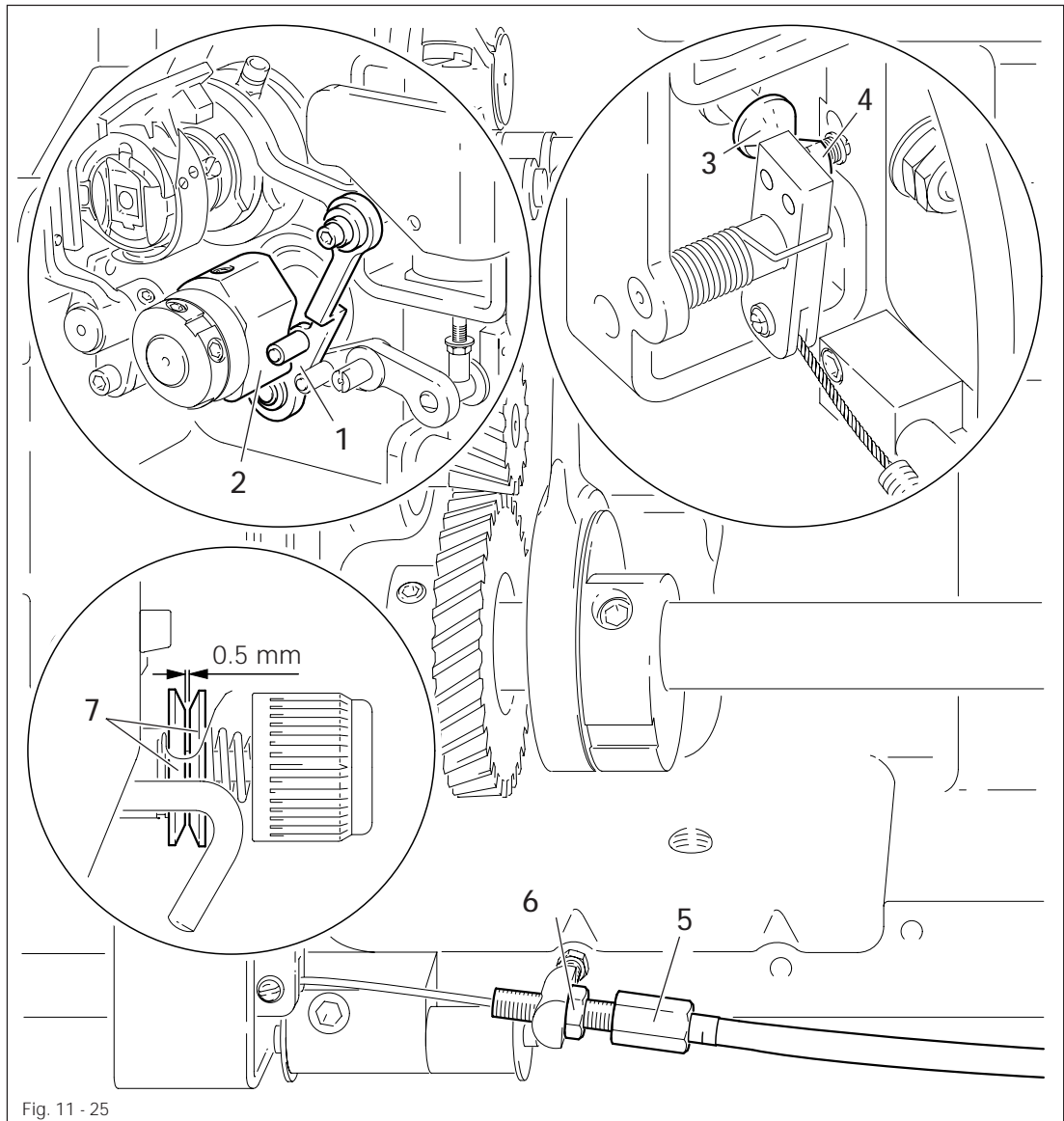

- Press the roller of the roller level 1 over the magnet into the lowest point of the control cam 2.
- Turn the hand wheel in the rotating direction until the release olive 3 is resting on the highest point of the cam 4.
- Turn screw 5 (nut 6) according to the requirement.



## 11.06.07 Readjusting the control cam

### Requirement

When the take-up lever is at TDC, the roller lever 1 must be brought from the highest point of the control cam 2 and moved against bolt 4 (basic position).

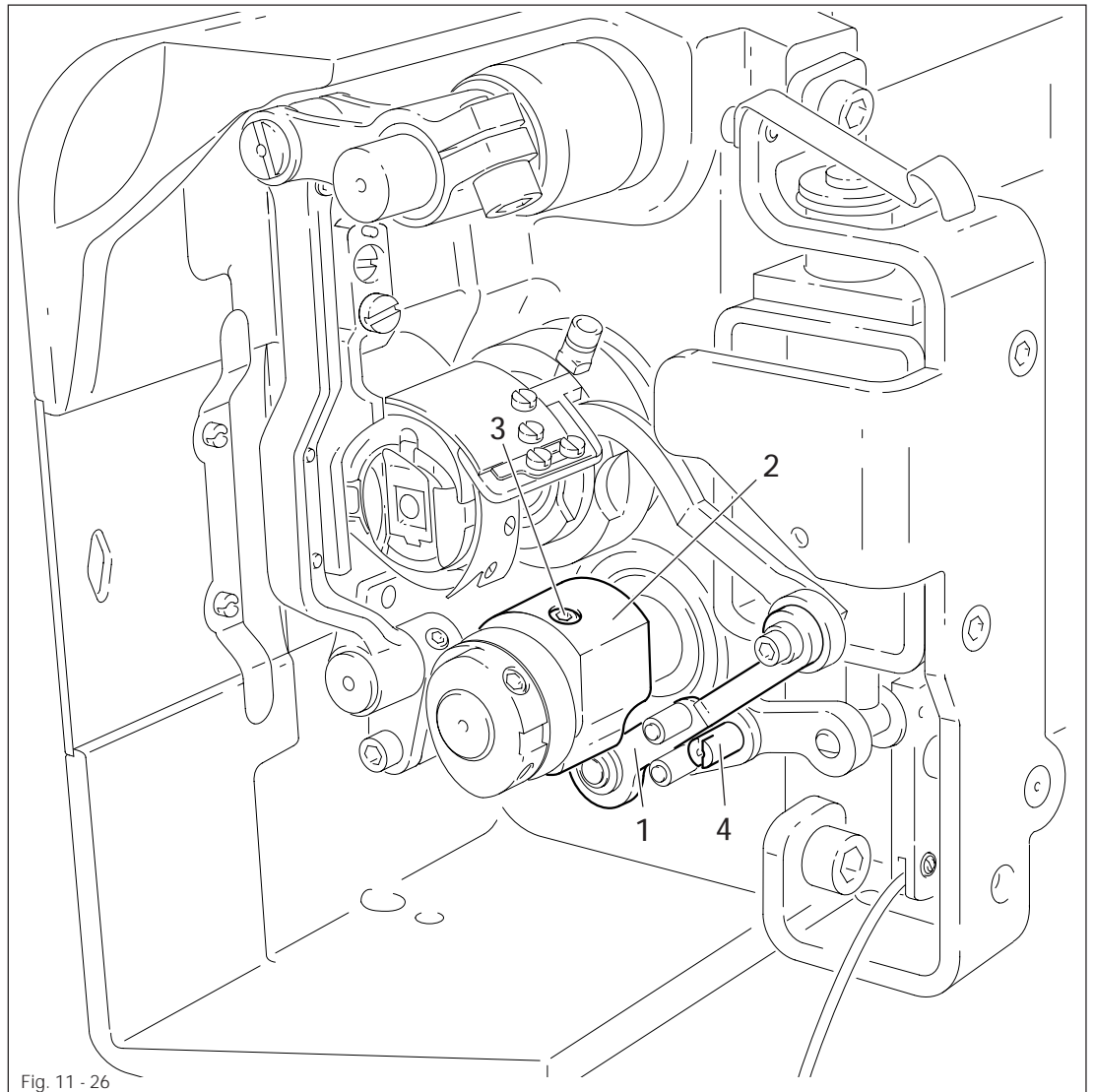
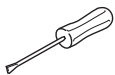

Fig. 11 - 26



- Switch on machine and sew a few stitches.
- Trigger cutting operation.
- Check to see if the thread was cut cleanly and roller level 1 is in basic position.
- If necessary, turn control cam 2 (screws 3) according to the requirement.

## 11.07 Adjusting the thread wiper -909/04

### 11.07.01 Thread wiper movement

#### Requirement

1. The thread wiper 5 must not strike against anything when it is moving.
2. When the take-up lever is at TDC, the thread wiper 5 is to move under the needle point and clear it by approx. 1 mm when the engaging solenoid 2 is operated.

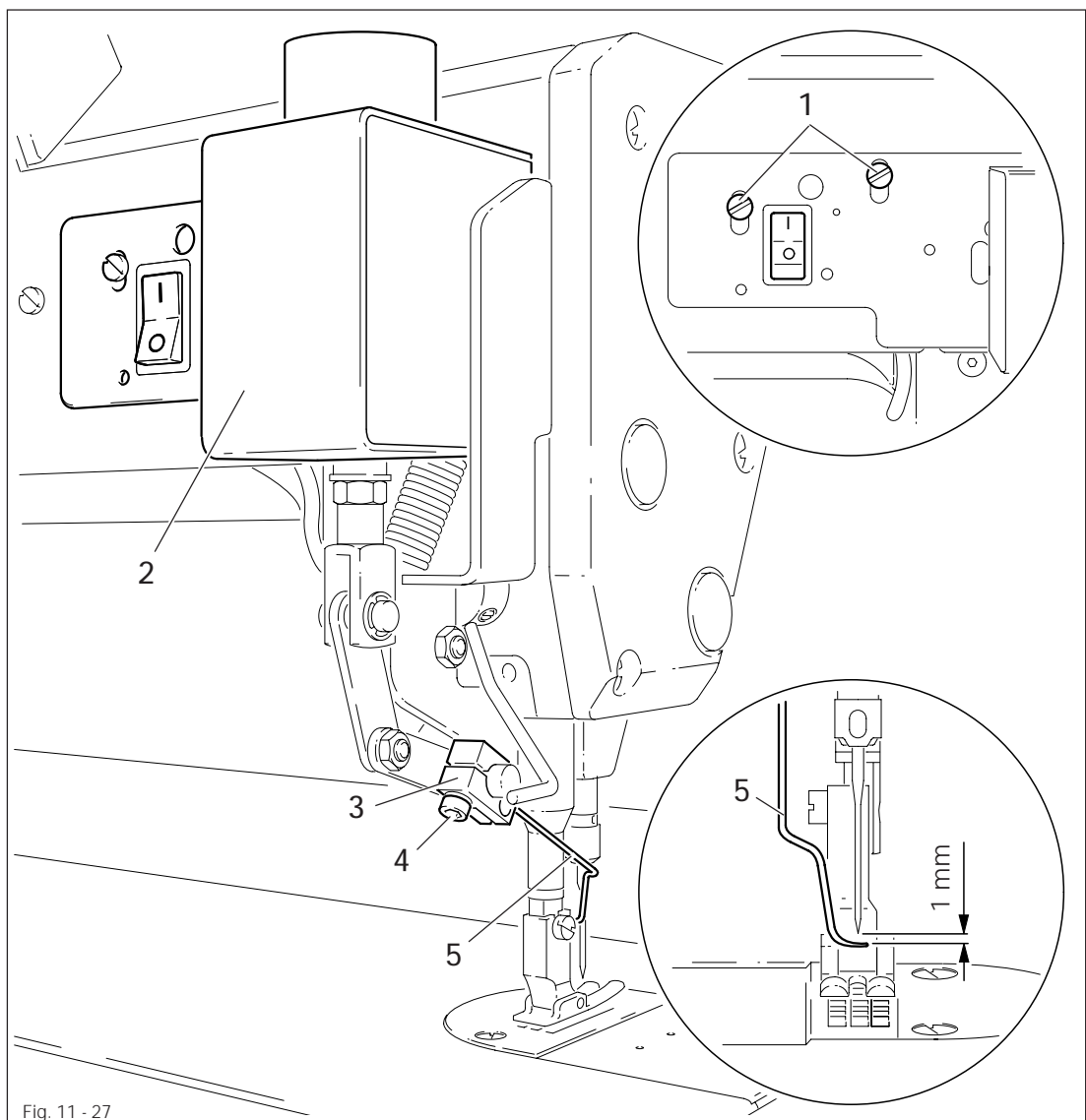
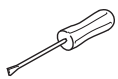

Fig. 11 - 27



- Bring the take-up lever to TDC.
- Loosen screws 1.
- Push thread wiper 2 parallel to the bedplate to the very top and tighten screws 1 slightly.
- Turn bracket 3 (screw 4) according to requirement 1.
- Move thread wiper 2 parallel to the bedplate according to requirement 2.
- Tighten screws 1.

## 11.07.02 Thread wiper position

**Requirement**

Seen from the direction of sewing

1. The point of the thread wiper 5 must be approx. 1 - 1.5 mm to the right of the needle, and
2. The thread wiper 5 must be approx. 2 mm in front of the needle in its foremost position.

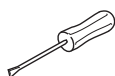
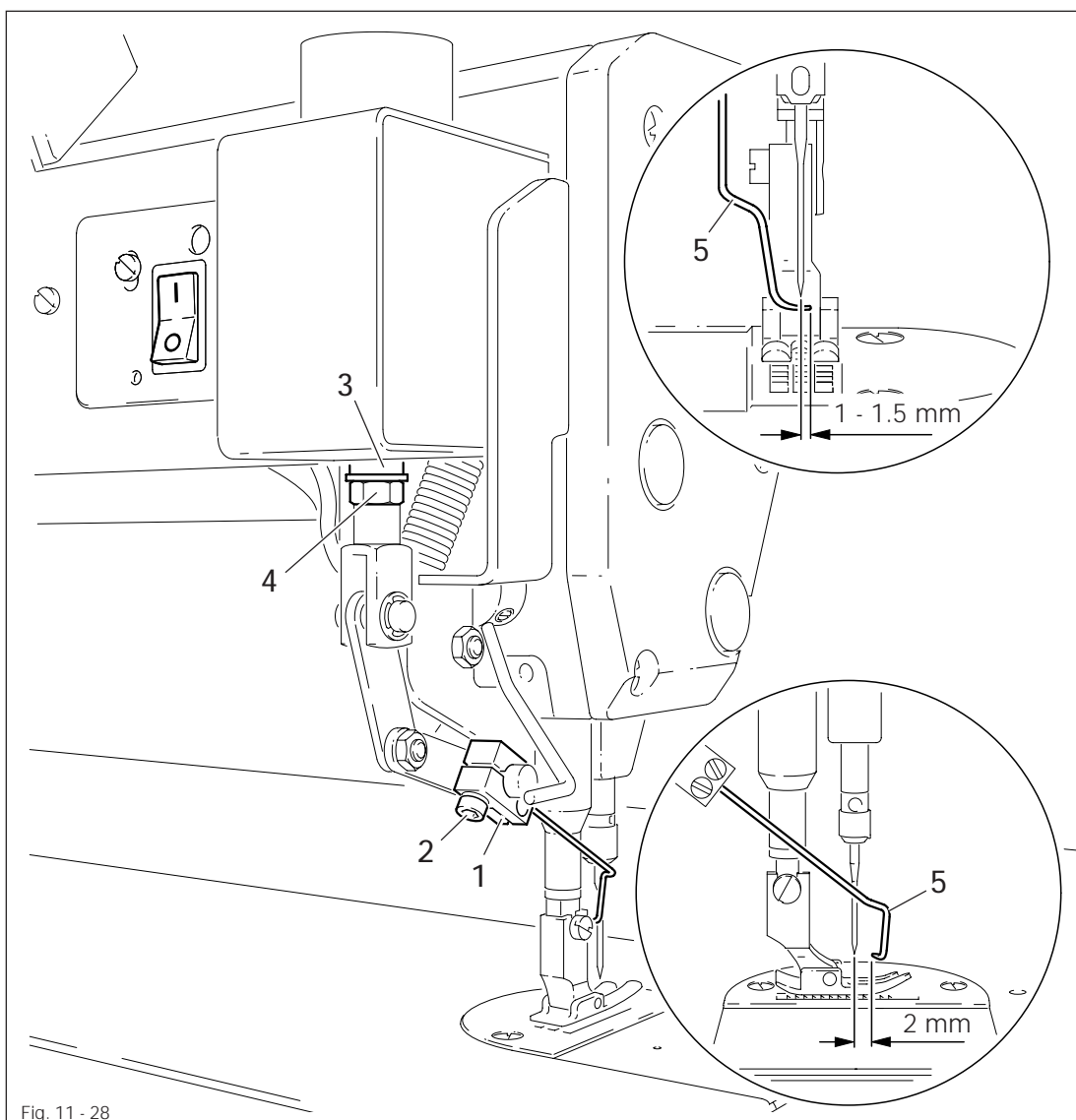

- Slide bracket 1 (screw 2), without turning it, on the shaft according to requirement 1.
- Turn rod 3 (nut 4) according to requirement 2.

## 11.08 Adjusting the automatic presser foot lift -910/06

### Requirement

When the automatic presser foot lift is operated, the clearance between the presser foot and the needle plate must be **9 mm** for a small needle bar stroke and **13 mm** for a large needle bar stroke.

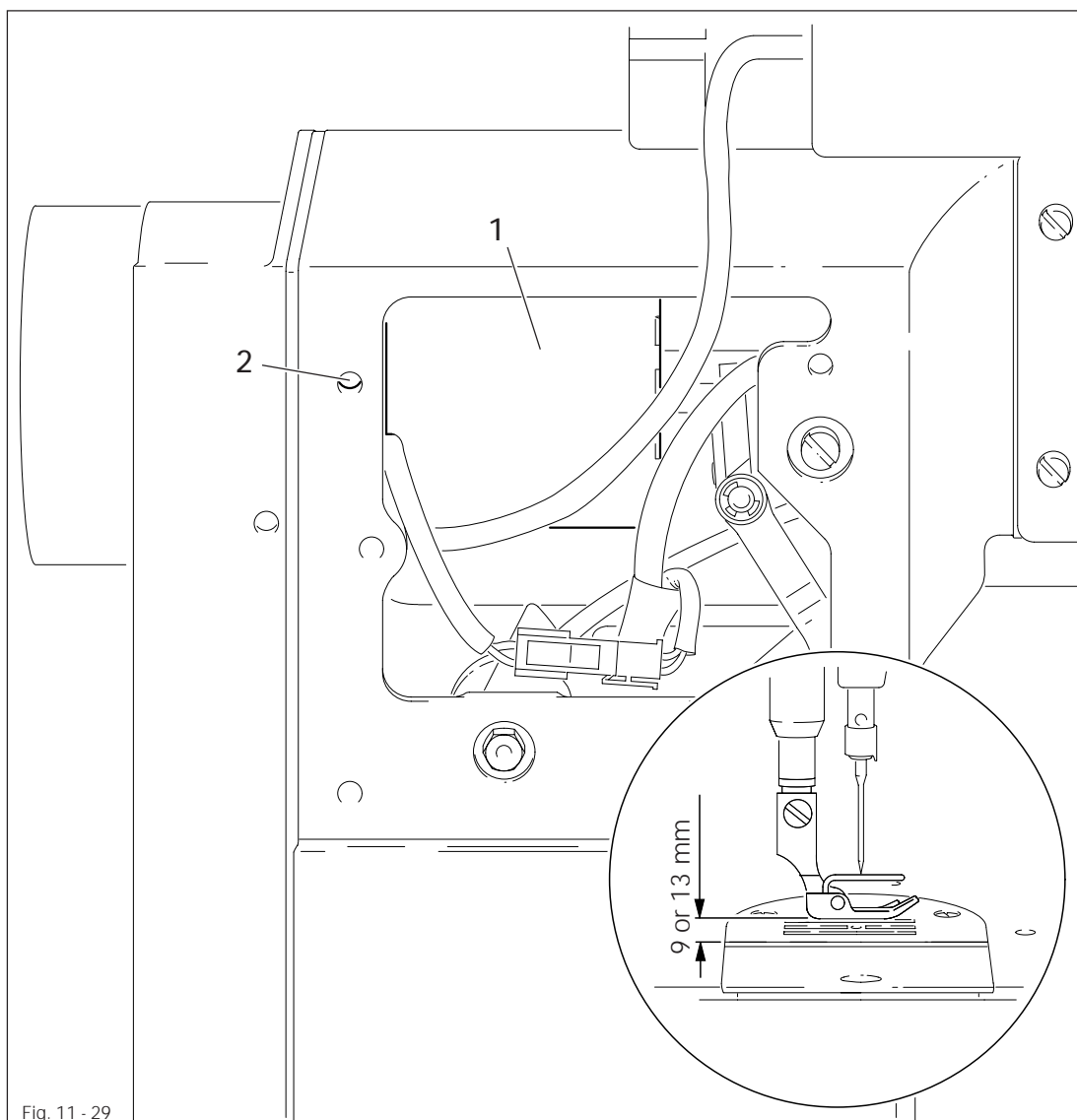
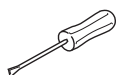

Fig. 11 - 29



- Move magnet 1 (screw 2) according to the requirement.

11.09

## Adjusting the backtacking mechanism -911/37

**Requirement**

With the largest stitch length selected,

1. when pressure is applied to plunger **3**, there must be a distance of approx. **2 mm** between it and lever **1**.
2. when the backtacking mechanism is operating, lever **1** must be pressed down fully.

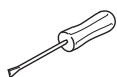
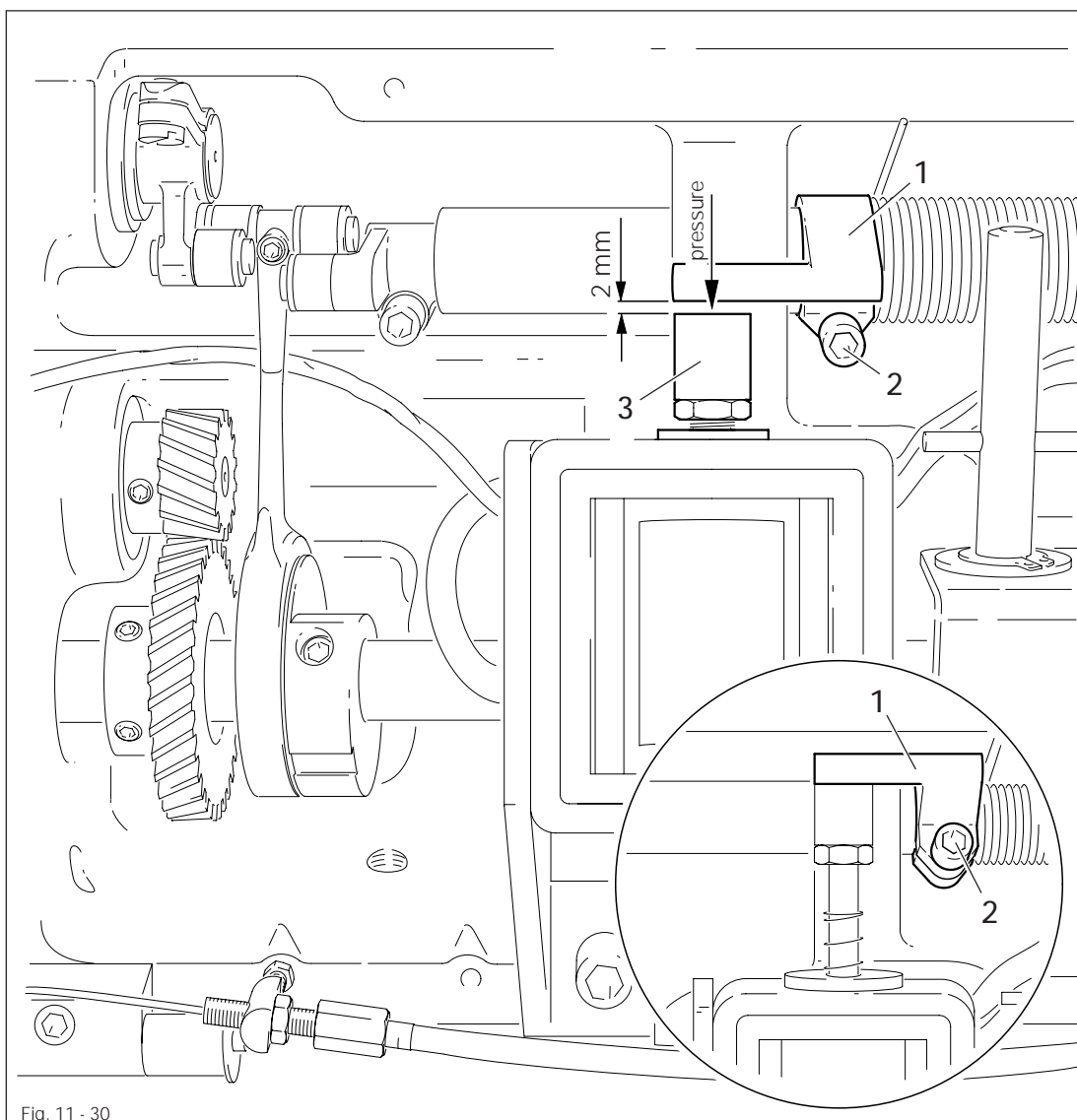

- Turn lever 1 (screw 2) according to the requirement.

# PFAFF

G.M. PFAFF  
Aktiengesellschaft

Postfach 3020  
D-67653 Kaiserslautern

Königstr. 154  
D-67655 Kaiserslautern

Telefon: (0631) 200-0  
Telefax: (0631) 172 02  
Telex: 45753 PFAFF D

Gedruckt in der BRD  
Printed in Germany  
Imprimé en R.F.A.  
Impreso en la R.F.A.  
Stampato in R.F.G.  
отпечатано ФРГ