

M832・M852

M832 Series 安全縫いマシン
Safety stitch machines

M852 Series オーバーロックマシン
Overedgers

Parts Checker



PEGASUS®

1

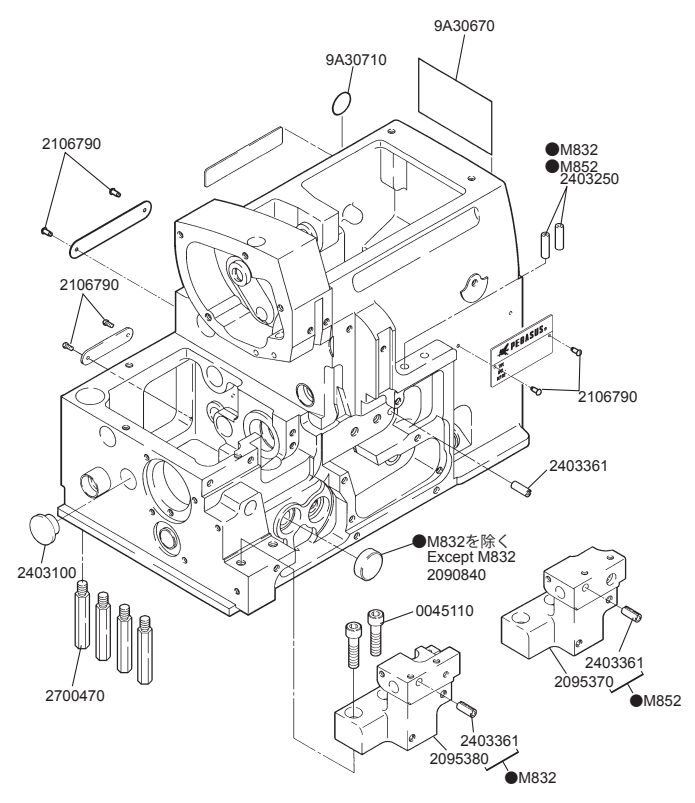

2

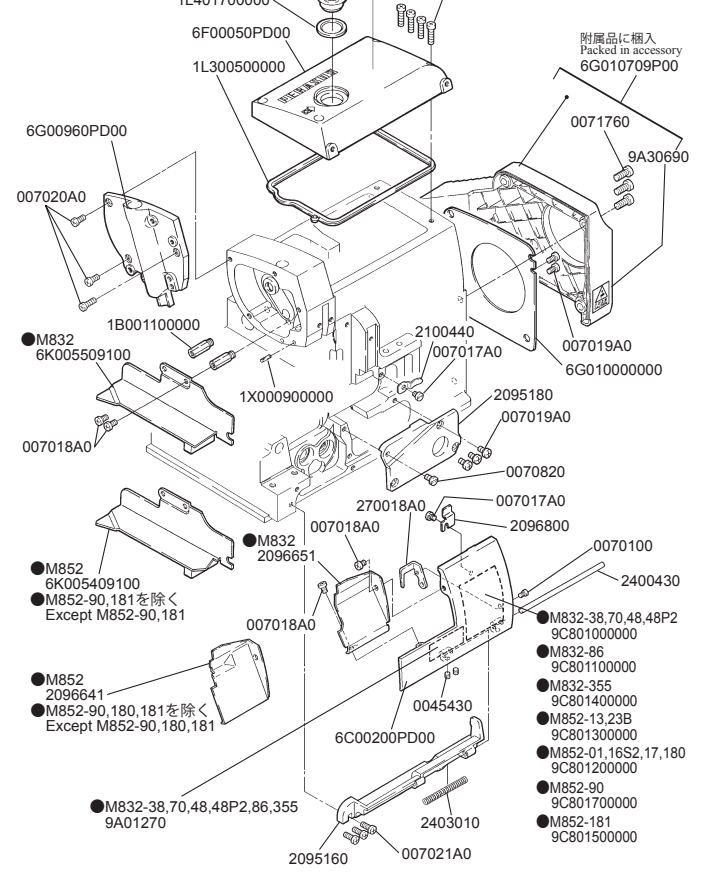

3

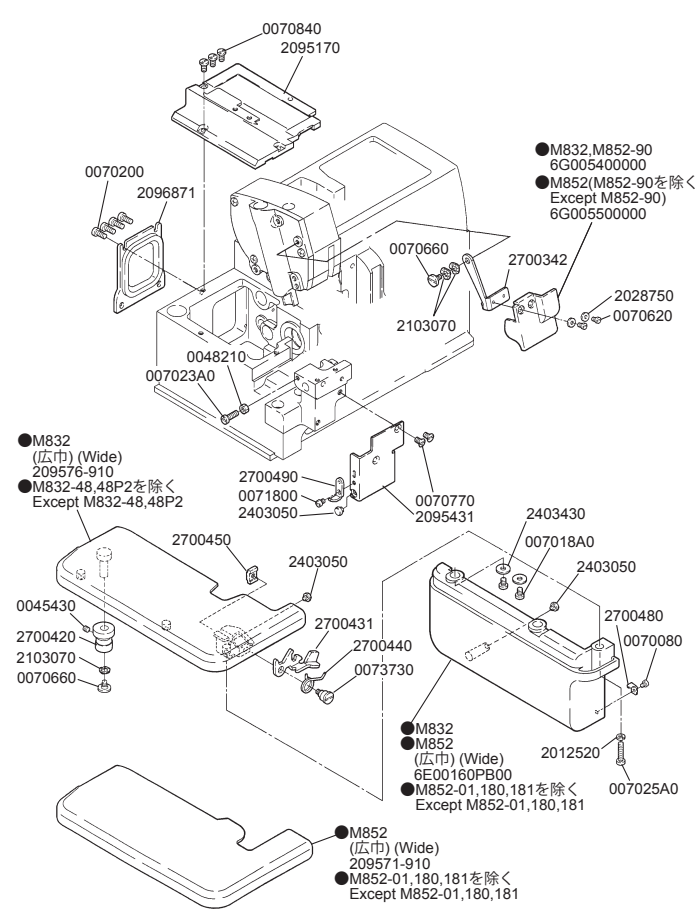

4

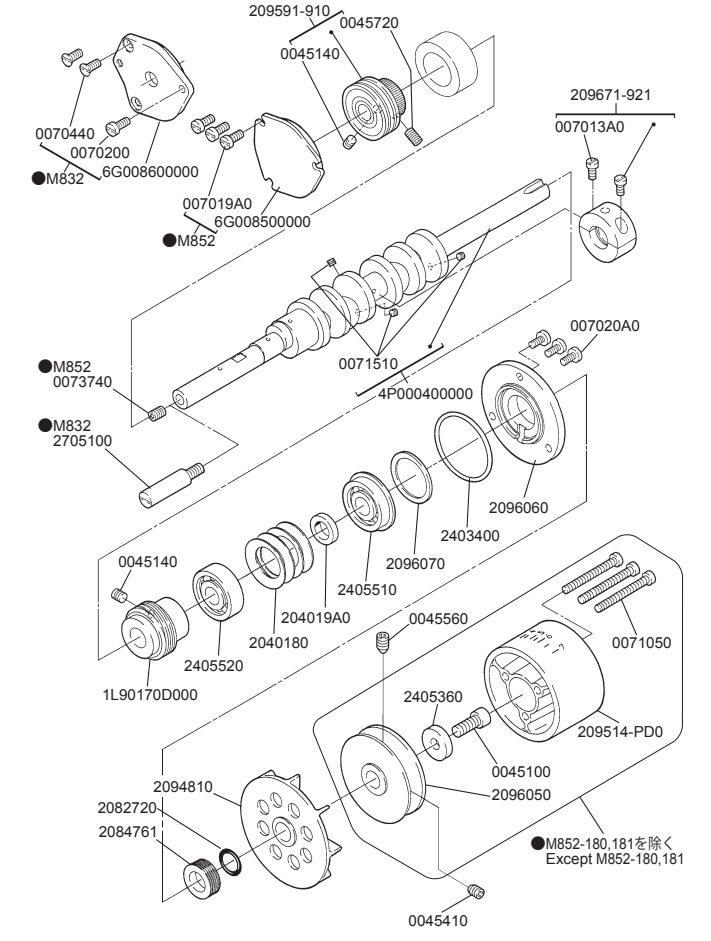

5

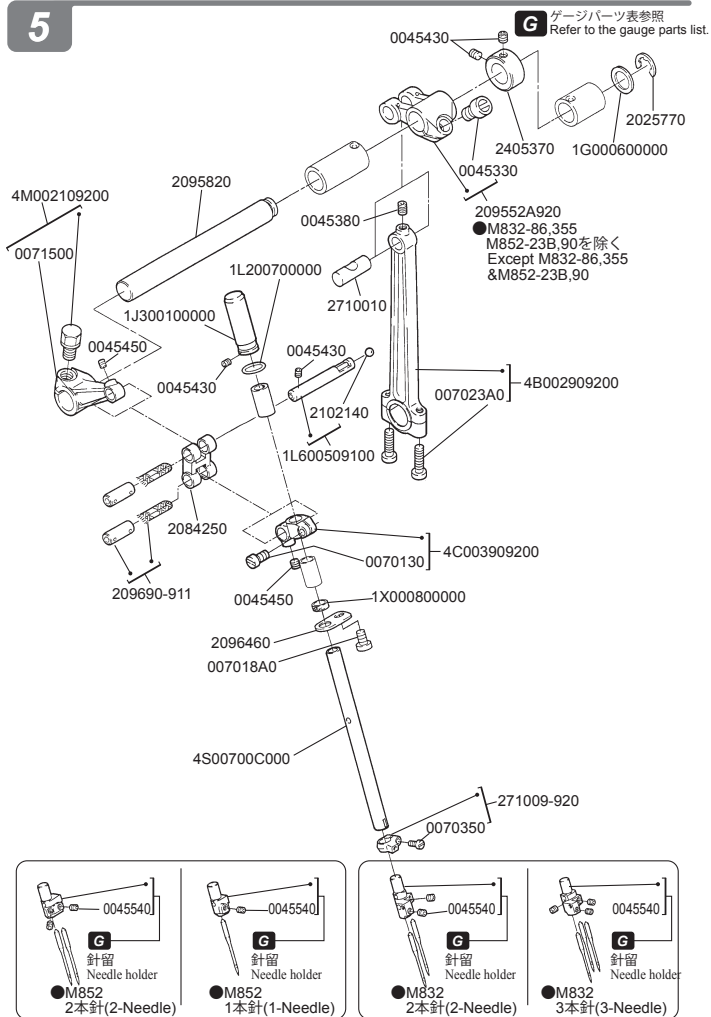

6

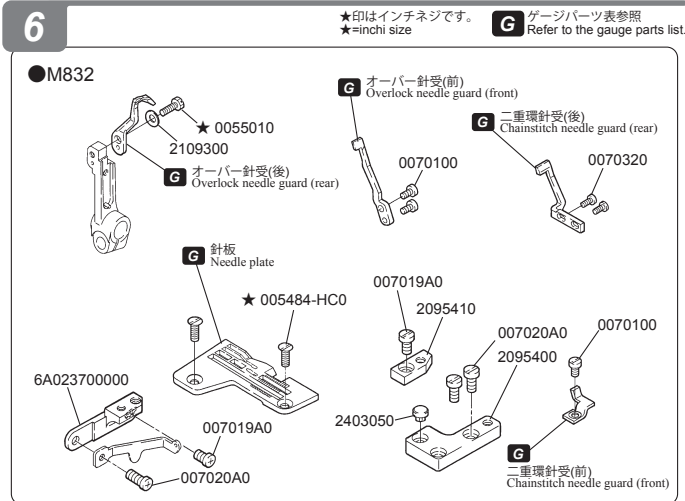

●M852

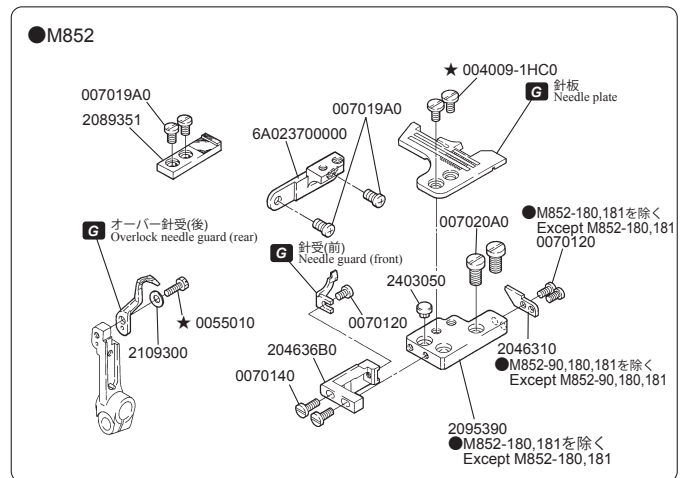

7

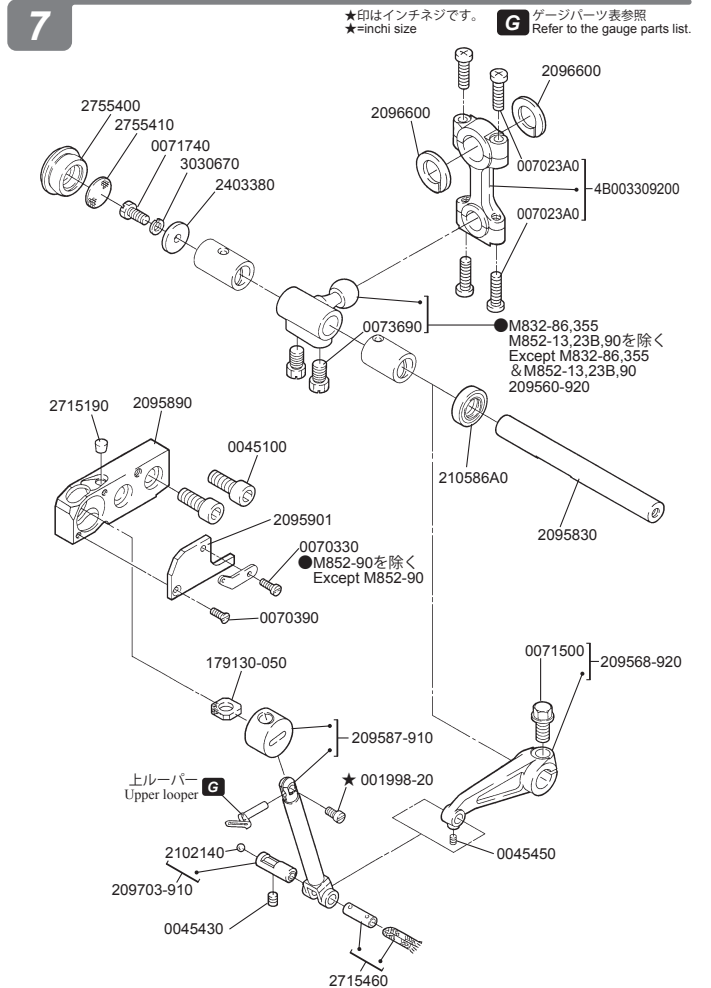

8

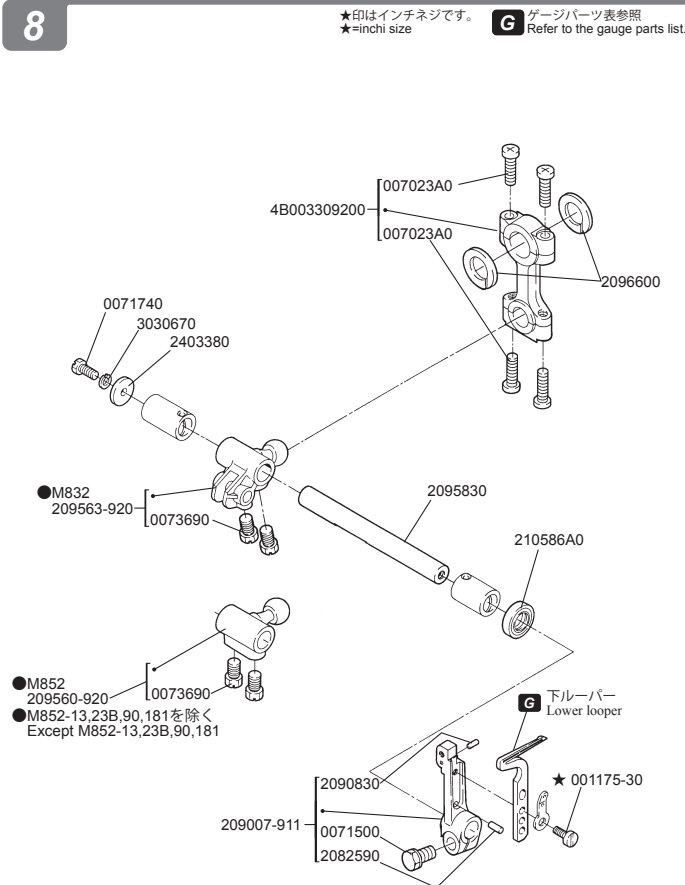

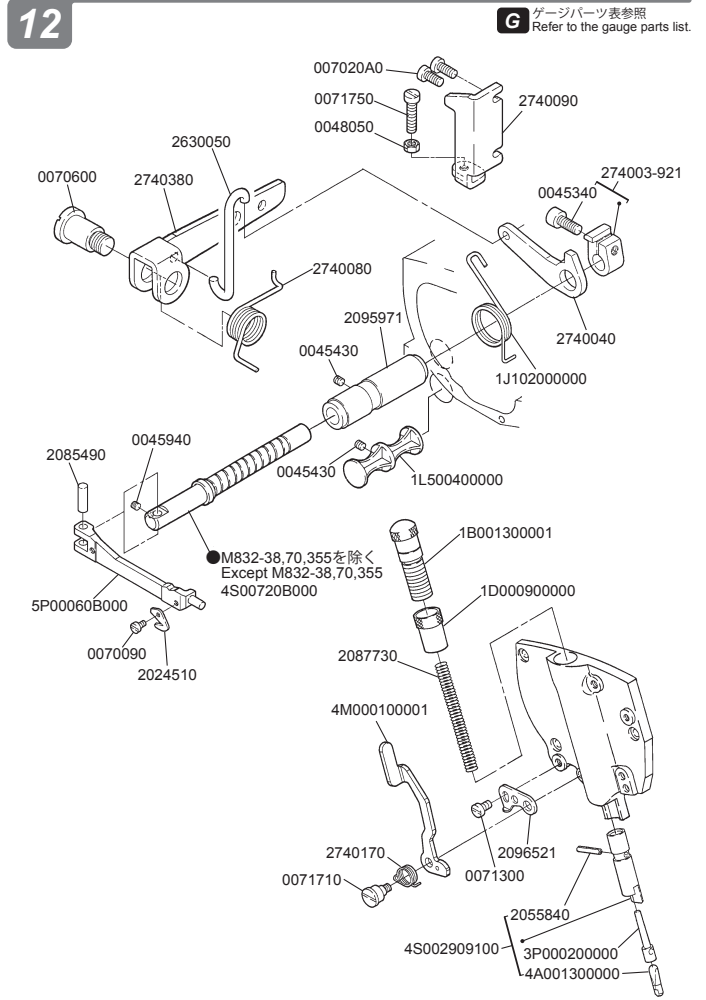
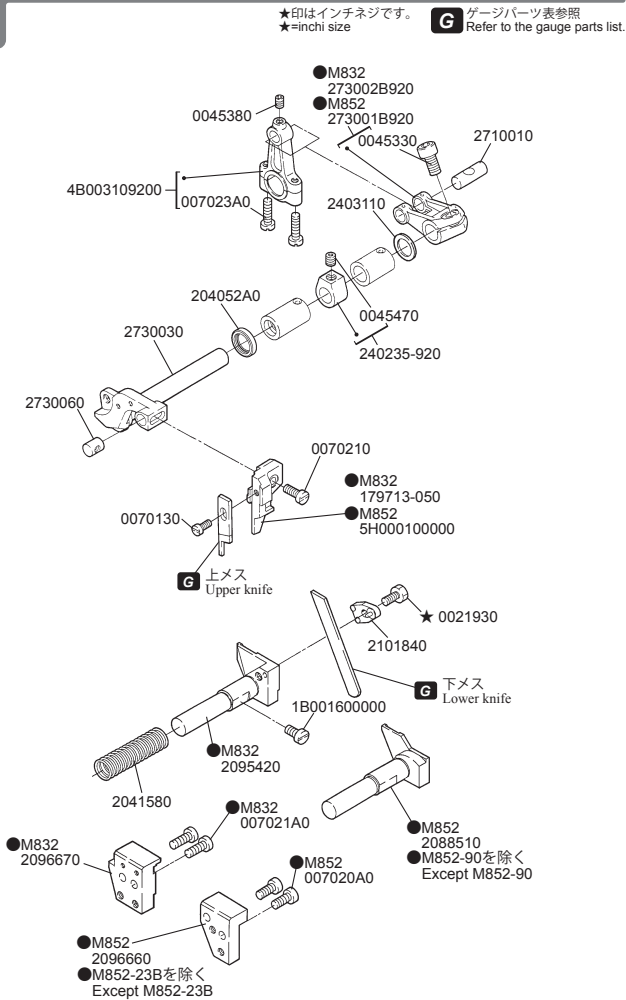
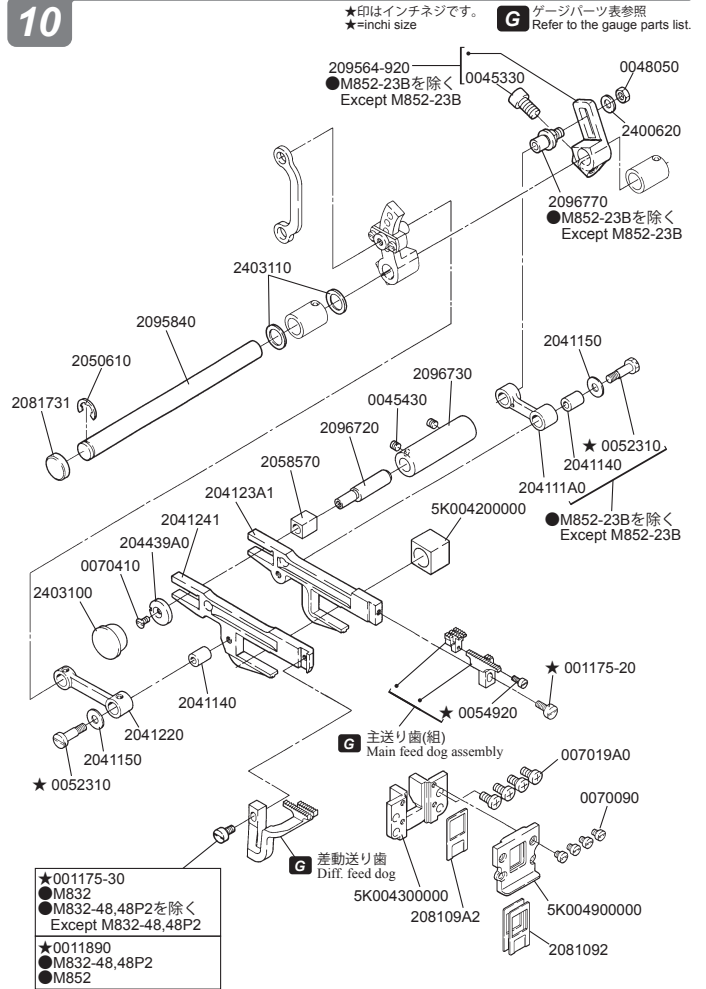
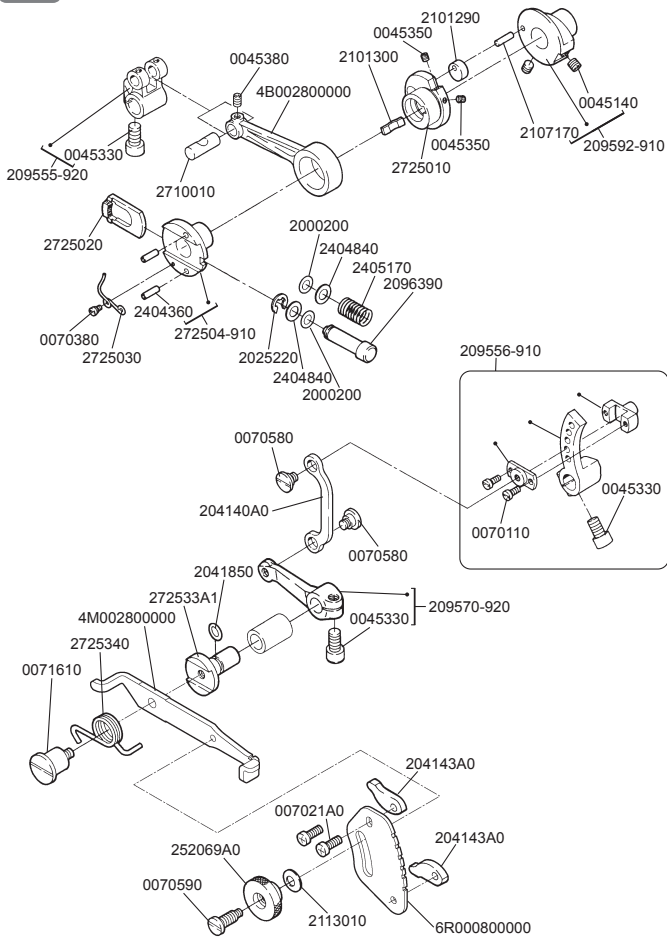

●M832
M832-48,48P2,86を除く
Except M832-48,48P2,86

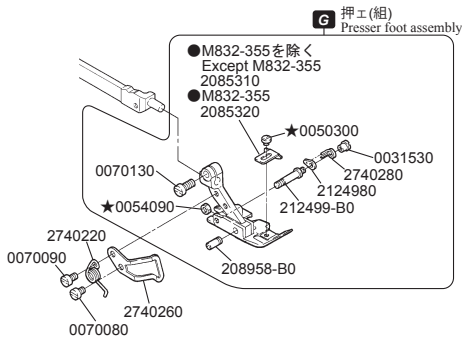

●M852

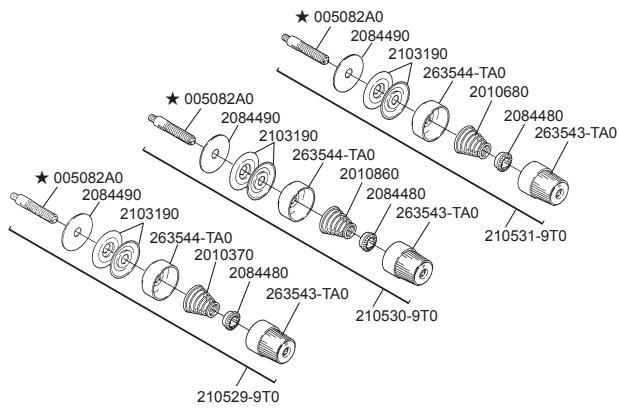
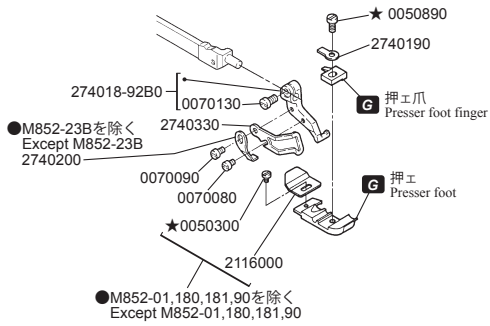

●M852
M852-13,90,181を除く
Except M852-13,90,181

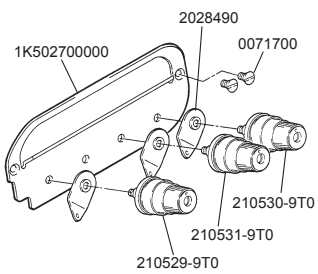

●M832
M832-355を除く
Except M832-355

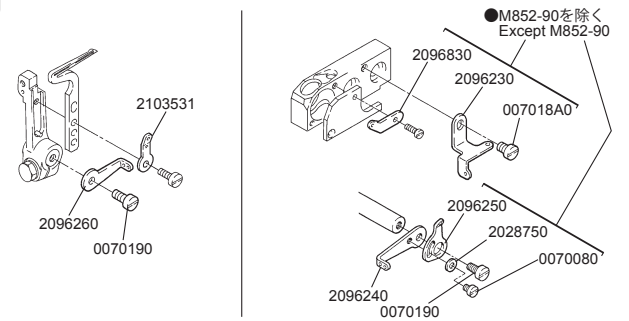
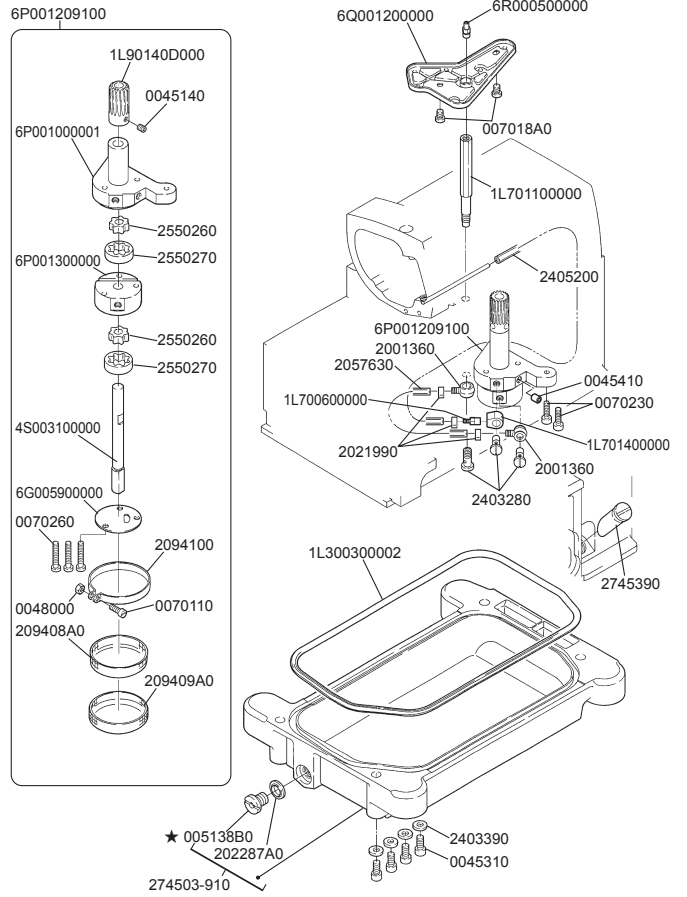
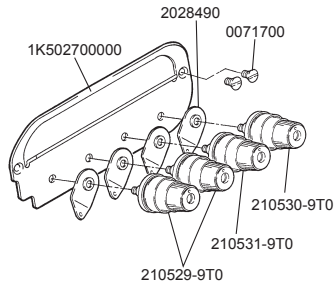

●M832

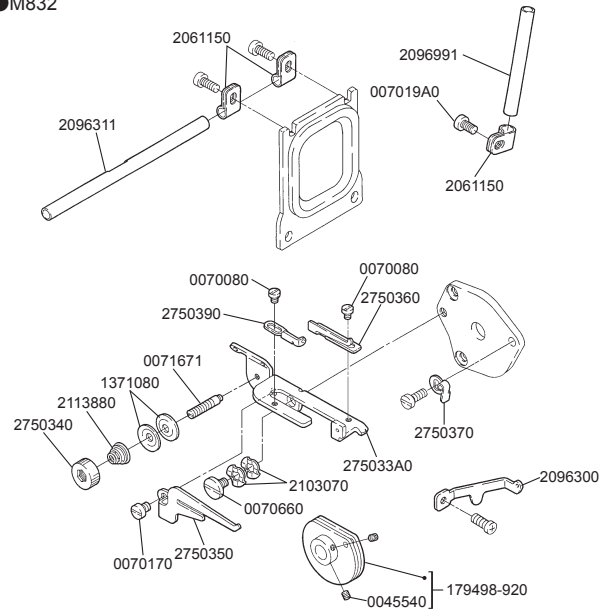

●M832

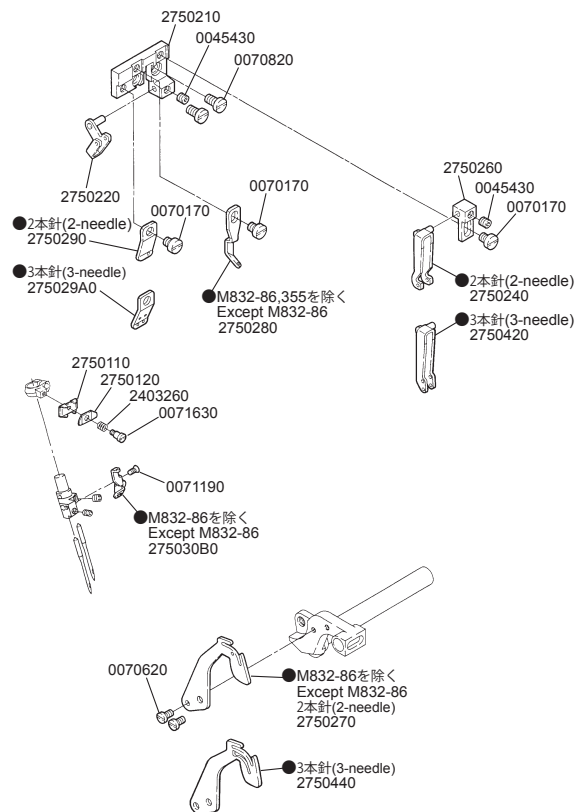

●M852

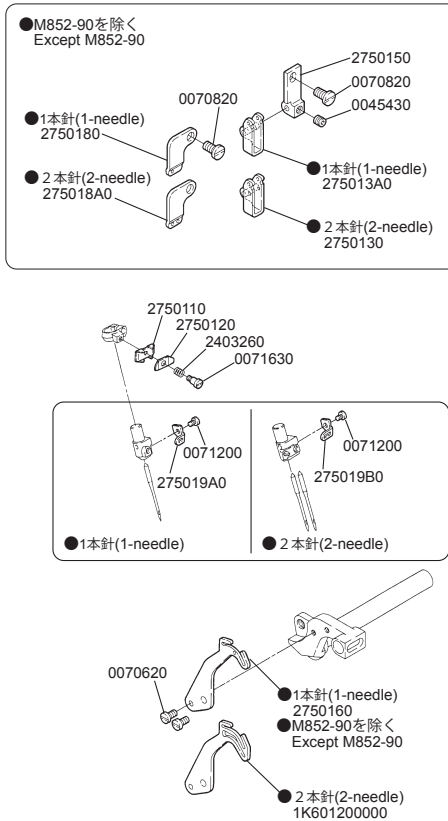

●M832

★印はインチネジです。 ★=inch size
G ゲージパーツ表参照。 Refer to the gauge parts list.

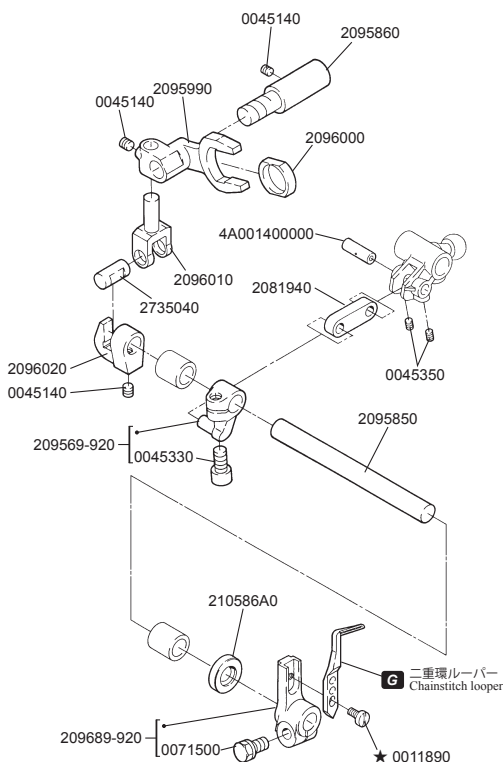

●M852-90を除く
Except M852-90

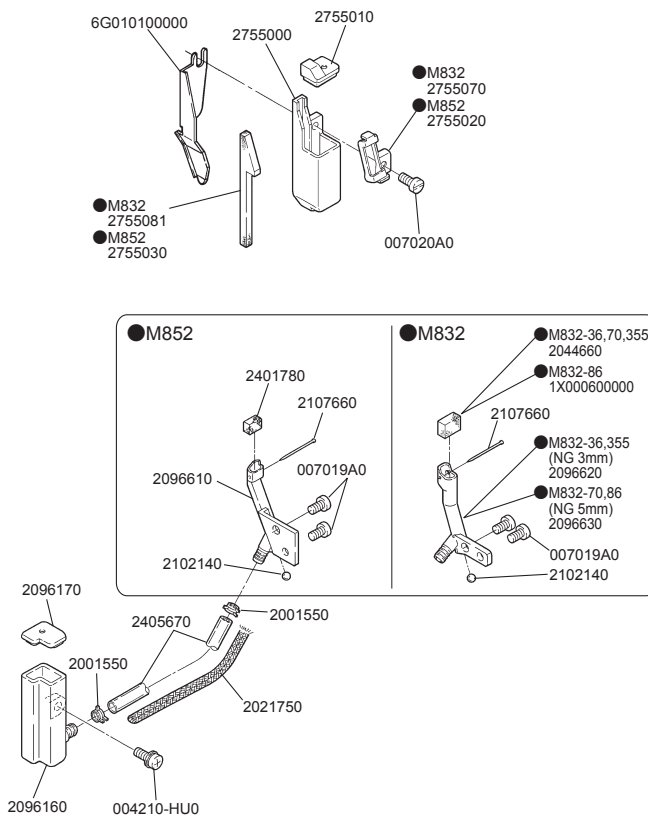

- 3本立(3-spool) 9E0012C9P00
- 4本立(4-spool) 9E0012B9P00
- 5本立(5-spool) 9E0012A9P00
- 6本立(6-spool) 9E001209P00

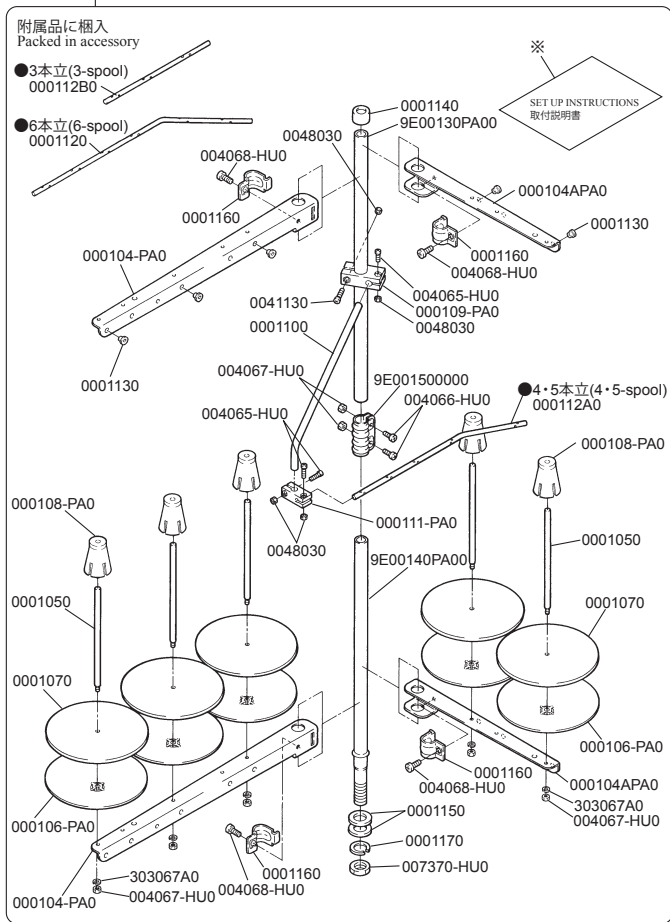

付属品に梱入
Packed in accessory

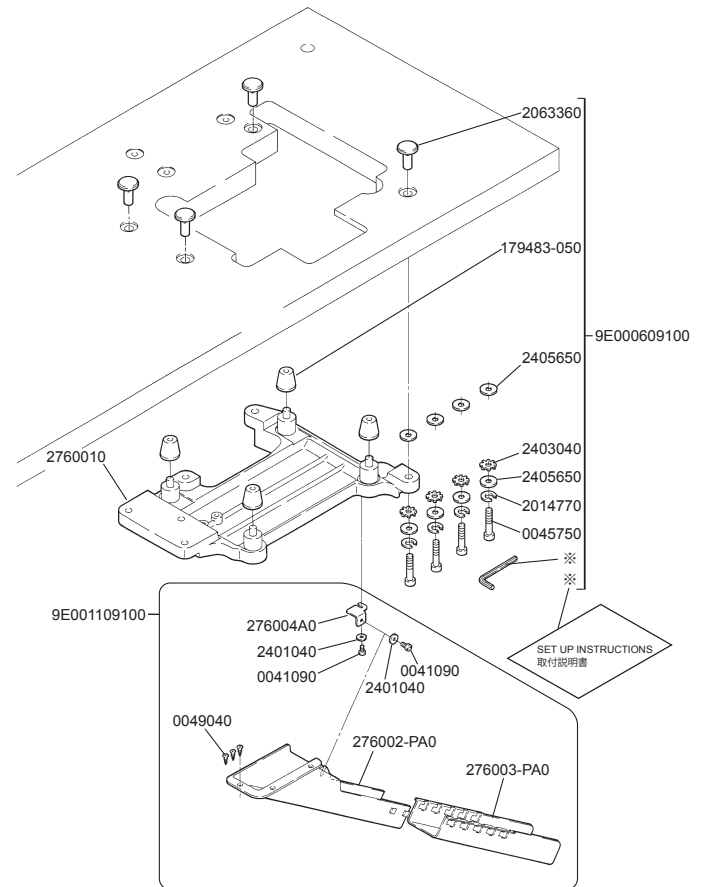

★印はインチネジです。
★=inchi size

G ゲージパーツ表参照
Refer to the gauge parts list.

●M832-38,70,355

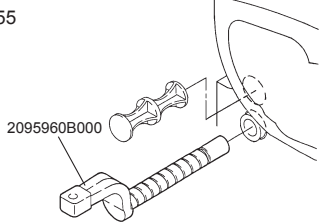

●M832-48,48P2

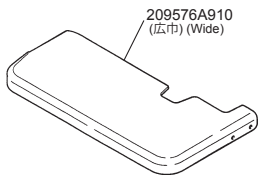

●M832-48

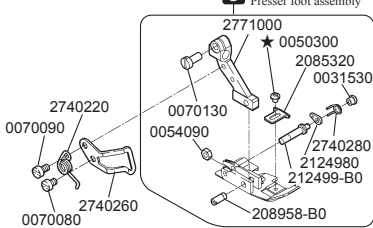

●M832-48P2

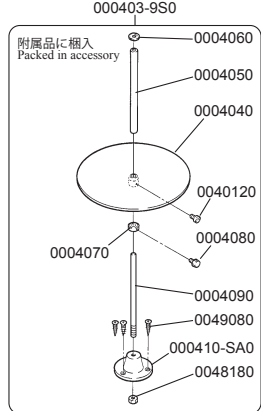
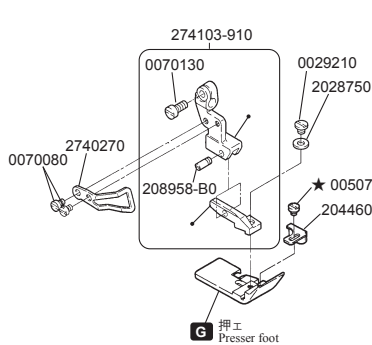

●M832-48,48P2

★印はインチネジです。
★=inchi size

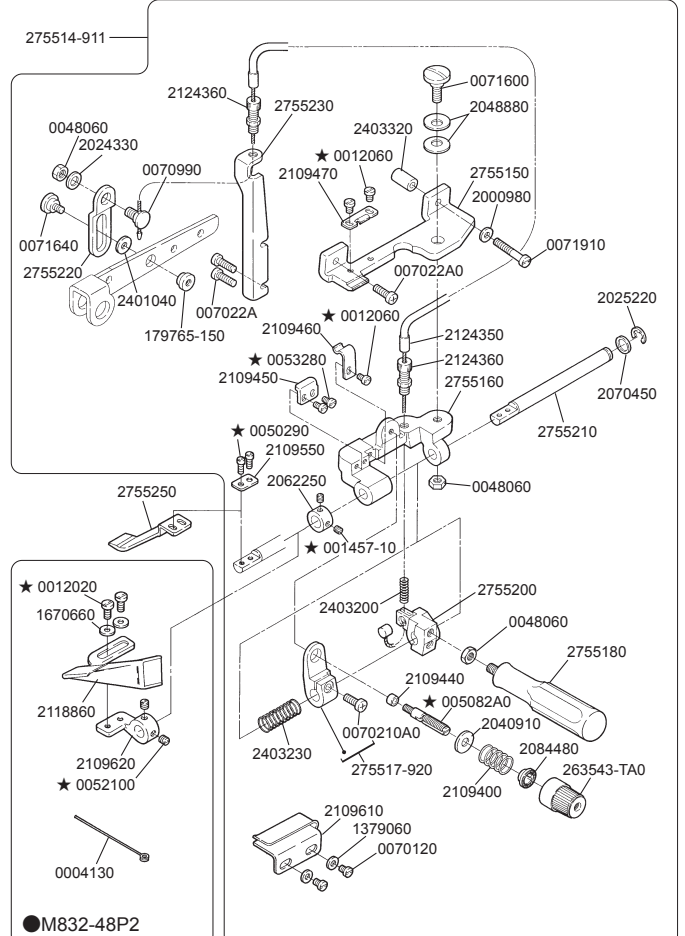

●M832-86

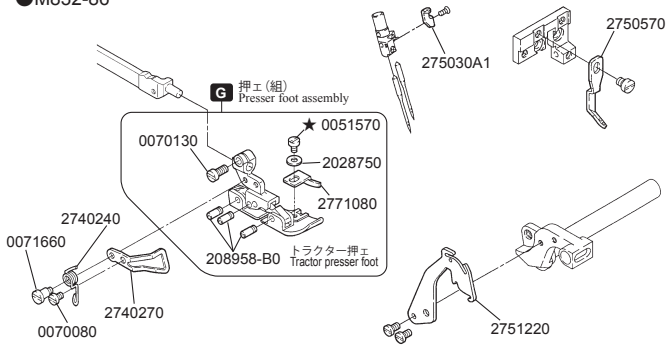

●M832-86,355

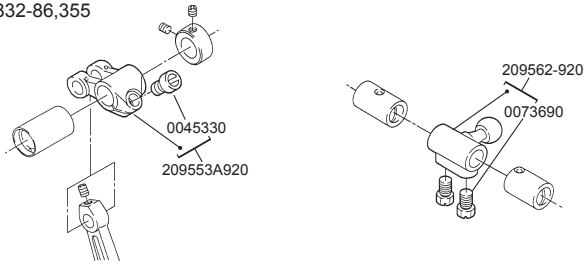

●M832-355

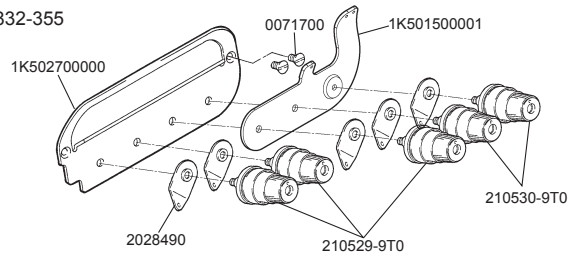

●M852-13

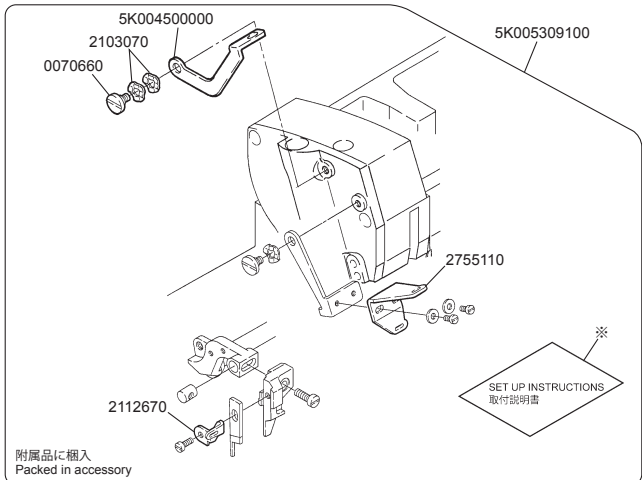
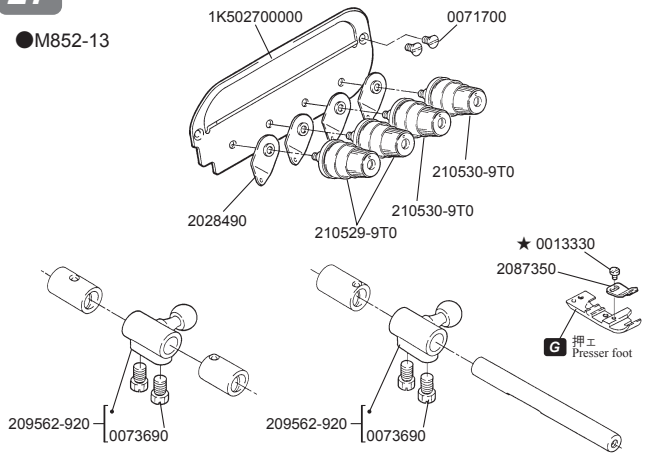

●M852-01

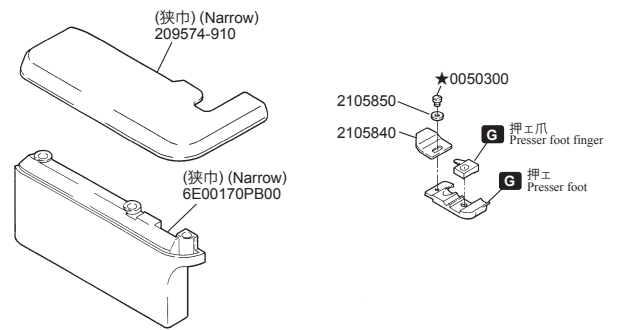
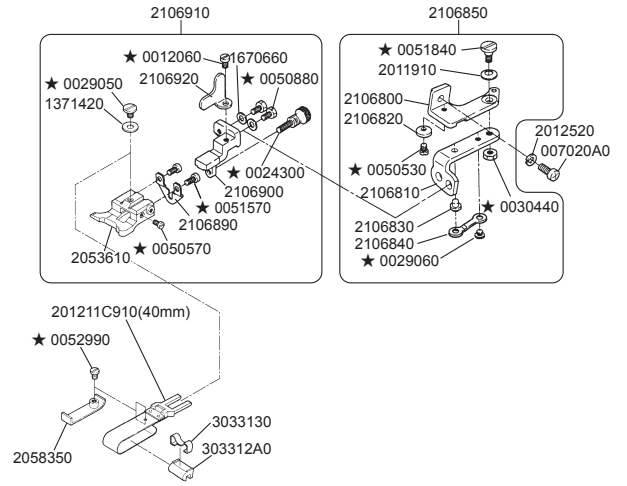

●M852-16S2,17,23B



●M852-23B

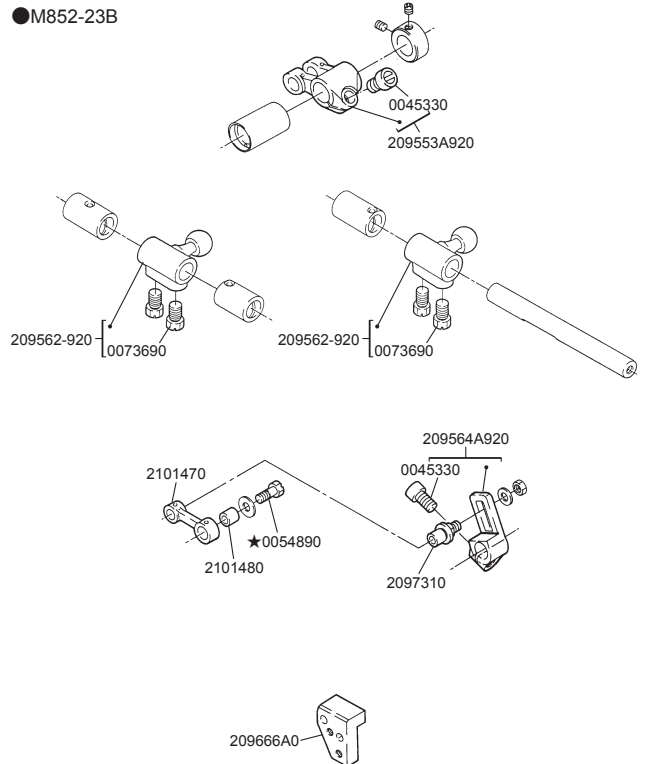

●M852-90

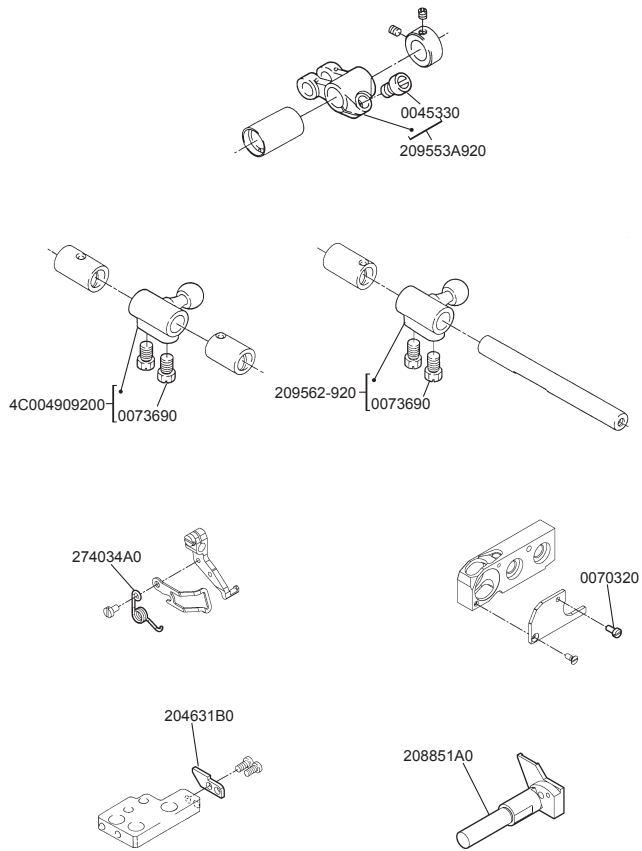

●M852-90

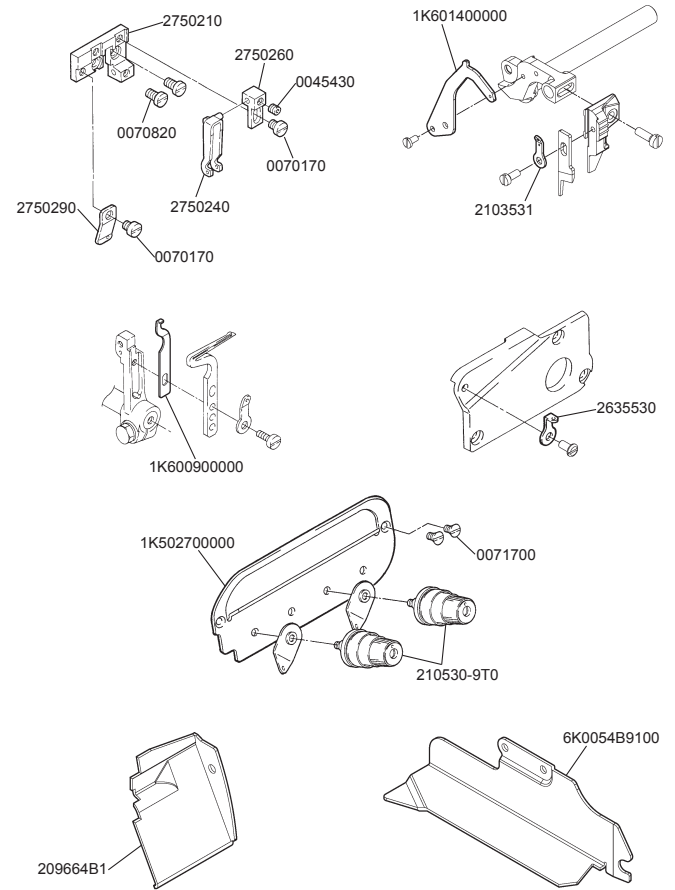

●M852-180,181

★印はインチネジです。
★=inch size

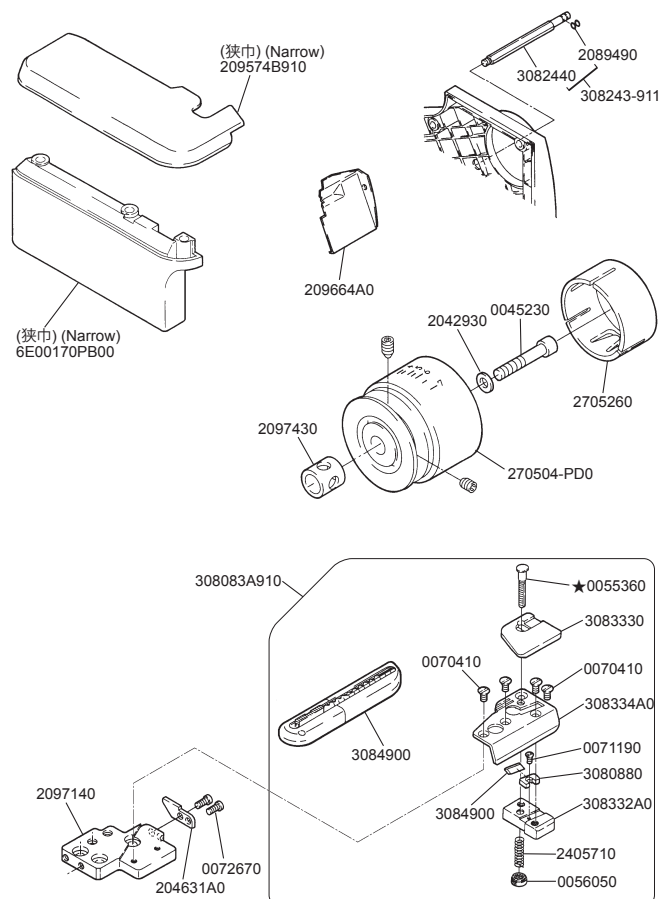

●M852-180

★印はインチネジです。
★=inch size

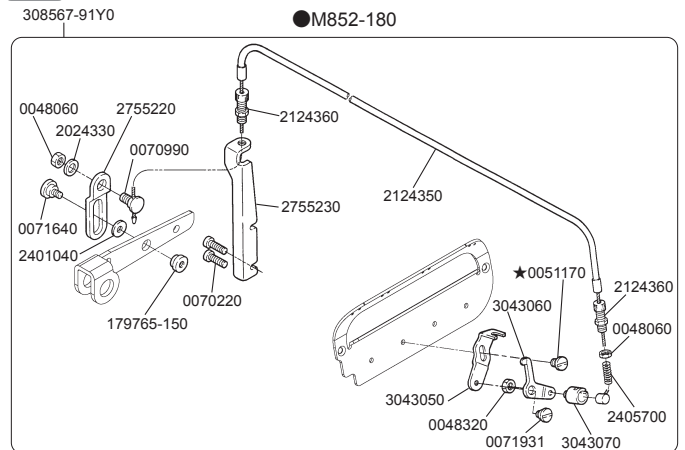

304314A9100

●M852-181

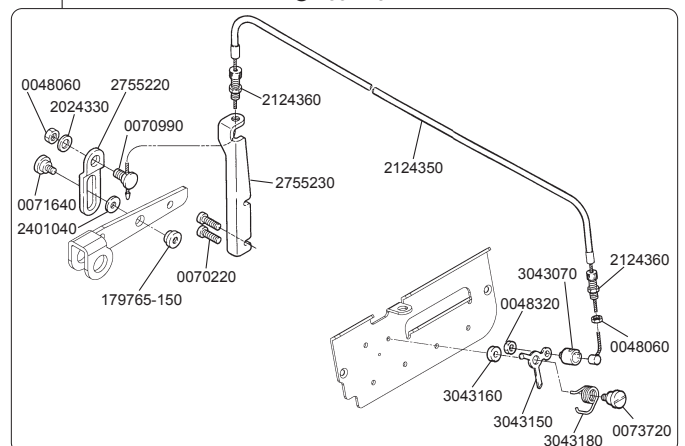

●M852-181

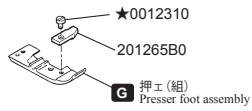

6K0054A9100

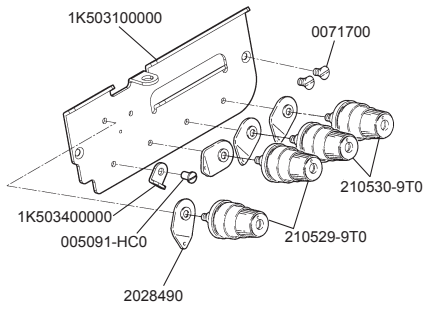
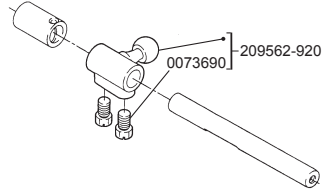
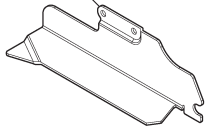

M832 ゲージパーツ表

M832 GAUGE PARTS LIST



マシン形式 MACHINE TYPE /SPEC.	ゲージ GAUGE		針板 NEEDLE PLATE	主送り歯(組) MAIN FEED DOG ASSY.	主送り歯本体 MAIN FEED DOG	補助送り歯 AUX. FEED DOG	差動送り歯 DIFF. FEED DOG	押エ(組) PRESSER FOOT ASSY.	上ルーバー UPPER LOOPER	下ルーバー LOWER LOOPER	二重環ルーバー CHAINSTITCH LOOPER	上メス UPPER KNIFE
	NG	SW										
M832-38	3	4	2043671	2080660	(2043960)	(2080600)	2082190	2771180	2047020 #4	2040720	2096850	201121A0
M832-48	3	4	2049401	2080740	(2049310)	(2080610)	2044201	2771200	2047020 #4	2040720	2096850	201121A0
M832-48P2	3	4	2049401	2080740	(2049310)	(2080610)	2044201	204502A1	2047020 #4	2040720	2096850	201121A0
M832-70	5	5	204360A1	2080630	(204248B0)	(2080590)	2082150	2771190	2047020 #4	2040720	2096850	201121A0
M832-86	5	6	2045291	2080640	(2043940)	(2080590)	2082170	2771220	2047030 #6	2040720	209685A0	201121A0
M832-355	3×2	4	2086481	2080660	(2043960)	(2080600)	2082190	277118A0	2097331 #14	2040720	2096850	201121A0



マシン形式 MACHINE TYPE /SPEC.	ゲージ GAUGE		下メス LOWER KNIFE	オーバー針受け OVERLOCK NEEDLE GUARD		二重環針受け CHAINSTITCH NEEDLE GUARD		針留 NEEDLE HOLDER	針 NEEDLE
				前		後			
				FRONT	REAR	FRONT	REAR		
M832-38	3	4	2041610	2096680	2090090	2045360	2096690	277027-921	DC×27 #14
M832-48	3	4	2041610	2096680	2090090	2045360	2096690	277027-921	DC×27 #14
M832-48P2	3	4	2041610	2096680	2090090	2045360	2096690	277027-921	DC×27 #14
M832-70	5	5	2041610	2096680	2090090	2040420	209669A0	277029-920	DC×27 #14
M832-86	5	6	2041610	2096680	2090090	2040420	209669A0	277029-920	DC×27 #21
M832-355	3×2	4	2041610	2096680	2090090	2045360	2096690	2K000309200	DC×27 #11

M852 ゲージパーツ表

M852 GAUGE PARTS LIST



マシン形式 MACHINE TYPE /SPEC.	ゲージ GAUGE		針板 NEEDLE PLATE	主送り歯(組) MAIN FEED DOG ASSY.	主送り歯本体 MAIN FEED DOG	補助送り歯 AUX. FEED DOG	差動送り歯 DIFF. FEED DOG	押エ(組) PRESSER FOOT ASSY.	押エ爪 PRESSER FOOT FINGER	上ルーバー UPPER LOOPER	下ルーバー LOWER LOOPER	上メス UPPER KNIFE
	NG	SW										
M852-01	—	4	2057731	208090-BF0	(204729ABF0)	(2046740)	204730-BF0	201152E0	201155C0 #34	2040620 #2	2040720	201121A0
M852-13	2	4	202554E1	208078-BF0	(204675ABF0)	(2046740)	204676-BF0	2087300	2087321 #38	2049631 #81	2040720	201121A0
	2	5	202499E1	208078-BF0	(204675ABF0)	(2046740)	204676-BF0	2087300	2087321 #38	2049631 #81	2040720	201121A0
M852-16S2	—	1.5	2054651	2089110	(204729A0)	(2089120)	2047300	201230C0	2055250 #57	2040620 #2	2040720	201121A0
M852-17	—	4	202546E1	208078-BF0	(204675ABF0)	(2046740)	204676-BF0	201230C0	2103710 #2	2040620 #2	2040720	201121A0
M852-23B	2.5	4.5	209508-451	209509-25F0	(209416-25F0)	(2046740)	209417A25F0	201230C0	208050A0 #61	2092091 #13	2049910	201121A0
M852-90	—	6	2P000106001	—	—	—	3F000102500	2772960	3T000300000	2F000200000 #16	2040720	2770000
M852-180	—	4	202618A1	208090A16F0	(204729B16F0)	(2046740)	204730A16F0	201473B0	3014330	2040620 #2	2040720	201121A0
M852-181	2	4	2097321	209740-16F0	(209741-16F0)	(2046770)	209742-16F0	2052530	2097340 #66	2049631 #81	2040720	201121A0



マシン形式 MACHINE TYPE /SPEC.	ゲージ GAUGE		下メス LOWER KNIFE	針受け NEEDLE GUARD		針留 NEEDLE HOLDER	針 NEEDLE
				前			
				FRONT	REAR		
M852-01	—	4	2022950	2046591	2090090	179630-920	DC×27 #9
M852-13	2	4	2022950	2046591	2090090	277022-920	DC×27 #9
	2	5	2022950	2046591	2090090	277022-920	DC×27 #9
M852-16S2	—	1.5	2022950	2046591	2090090	179630-920	DC×27 #11
M852-17	—	4	2022950	2046591	2090090	179630-920	DC×27 #9
M852-23B	2.5	4.5	2022950	2046591	2090090	277023-920	DC×27 #14
M852-90	—	6	2770091	2046591	2090090	277066-920	DC×27 #14
M852-180	—	4	2022950	2046591	2090090	179630-920	DC×27 #9
M852-181	2	4	2022950	2046591	2090090	277022-920	DC×27 #9

ペガサスミシン製造株式会社

本社 〒 553-0002 大阪市福島区鷺洲 5-7-2 TEL (06)6458-4739
FAX (06)6454-8785

PEGASUS SEWING MACHINE MFG. CO., LTD.

5-7-2, Sagisu, Fukushima-ku, Osaka 553-0002, Japan. Phone : (06)6458-4739
Telefax : (06)6454-8785

Cat. No. 9B100200001 December 2005

©2005 PEGASUS SEWING MACHINE MFG. CO., LTD.

このパーツチェッカーに記載されている内容は、改良のため予告なく変更することがあります。

The description in this PARTS CHECKER is subject to change without prior notice for improvement.