

INSTRUCTION

DX/UTC MANUAL

DX SERIES

Industrial Sewing Machines

DX9902-3U

DX9900-4U

First published : November 1997

Second edition : January 1999

No. 980101

KANSAI
SPECIAL®

INTRODUCTION

Thank you for your purchasing Kansai Special's DX/UTC Series.

Read and study this instruction manual carefully before beginning any of the procedures and save it for later use.

This instruction manual describes adjustments and maintenance procedures for the thread trimmer.

Refer to the DX Series instruction manual for other information.

CONTENTS

1. HOW TO USE THE THREAD TRIMMER	1
2. INSTALLING THE POSITION DETECTOR	1
3. ADJUSTING THE THREAD TRIMMER AIR CYLINDER	
3-1 Air cylinder stroke	2
4. ADJUSTING THE THREAD TRIMMER	
4-1 Home position of the knives (at the extreme right end of their stroke)	2
4-2 Upper knife at the extreme left end of its stroke	2
4-3 Position of each lower knife	2
4-4 Position of the points of the lower knives	2
4-5 Relationship between the lower knives and the needles	3
4-6 Relationship between the upper and lower knives	3
4-7 Overlap of the upper and lower knives	3
4-8 Adjusting the leaf springs	4
4-9 Relationship between lower knives, needle threads and looper threads ..	4
5. ADJUSTING THE THREAD RELEASER	
5-1 Thread releaser lever	5
5-2 Thread releaser plate	5
5-3 Thread releaser hook	5
6. SAFETY DETECTOR	5
7. ADJUSTING THE SPEED CONTROLLER AND AIR PRESSURE ..	6
8. ADJUSTING THE PRESSER FOOT LIFT	6
9. ADJUSTING THE AIR BLOWER	7
10. CONNECTING AIR LINES AND CORDS FOR PNEUMATIC DEVICES	
10-1 DX004U	8
10-2 DX2-3U	8
10-3 DX2-3U/LK	9

【1】 HOW TO USE THE THREAD TRIMMER

< Note >

Do not use this thread trimmer with no fabric under the presser foot.

Pressing the pedal with toe (position A) starts the machine.

Releasing the pedal (position B) stops the needle at the top/bottom of its stroke (adjustable with the motor).

If the needle stops at the bottom of its stroke as adjusted, pressing the pedal with heel (position C) raises the needle. As soon as the needle stops at the top of its stroke by pressing the pedal with heel, the thread trimmer gets actuated (if the needle stops at the top of its stroke as adjusted, the thread trimmer gets actuated by pressing the pedal with heel).

Returning the pedal to position B lowers the presser foot.

The presser foot can be raised or lowered freely by releasing the pedal (position B) or pressing the pedal with heel (position C) until the pedal is placed at position A for the next sewing operation after the threads are cut.

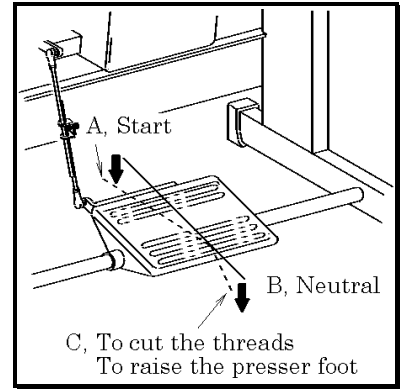

【2】 INSTALLING THE POSITION DETECTOR

Install position detector A and tighten screw B temporarily.

Fit positioner bar C onto the guide groove of the position detector. Then tighten screw D.

Turn on the motor.

< Note >

*Remove the connector for the thread trimmer cylinder.
Make sure the knife is retracted all the way.*

Press the pedal with heel after two to three stitches are formed by pressing the pedal with toe. Then the needle stops.

Loosen screws B for the position detector.

Turn the machine pulley while checking that the position of screws B is not shifted.

Align mark P on handwheel E with the alignment mark on the arm.

Then the needle bar is at the top of its stroke.

Tighten screws B to secure the position detector.

Check to see if the needle bar stops at the top of its stroke by pressing and then releasing the pedal.

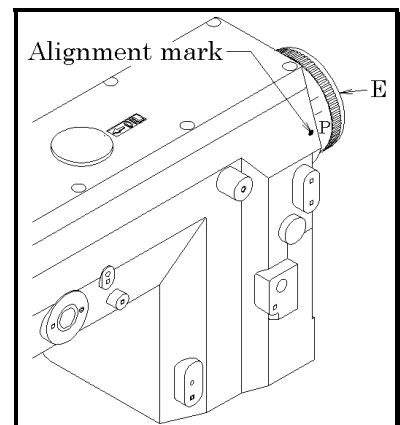
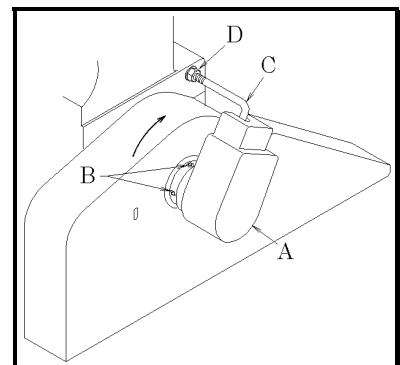

【3】 ADJUSTING THE THREAD TRIMMER AIR CYLINDER

3-1 Air cylinder stroke

The stroke of the air cylinder varies according to the gauge. Refer to the table below. Adjustment is made by loosening adjusting collars A and B.

Gauge	Stroke
4.8-10-10-10	39.2mm
5.0-13-13-13	41.6mm
9.5-9.5-9.5	37.1mm
8.5-8.5-8.5	37.1mm
6.4-6.4-6.4	37.1mm

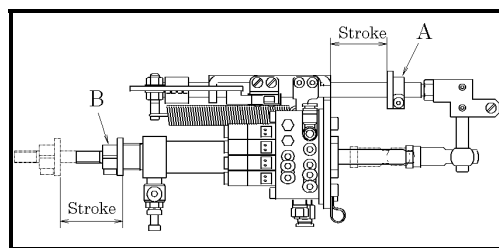

【4】 ADJUSTING THE THREAD TRIMMER

< Note >

When operating the thread trimmer by hand, bring the needle to the top of its stroke.

4-1 Home position of the knives (at the extreme right end of their stroke)

The home position of each knife varies according to the gauge.

Adjust distance A by referring to the illustration and the table below.

Then fasten collar B (see 3-1).

Gauge	Distance A
4.8-10-10-10	46.6mm
5.0-13-13-13	45.6mm
9.5-9.5-9.5	47.1mm
8.5-8.5-8.5	46.1mm
6.4-6.4-6.4	43.9mm

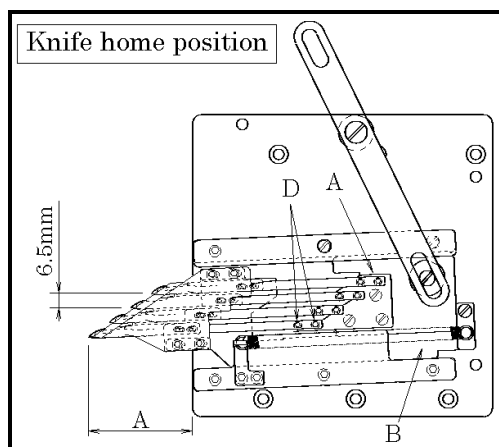

4-2 Upper knife at the extreme left end of its stroke

Lower knife carrier A and upper knife carrier B move to the left simultaneously.

Upper knife carrier B stops when reaching positioning stopper C.

4-3 Position of each lower knife

The lower knives should be parallel with each other. Adjustment is made by loosening screws D. Each distance between the points of the lower knives should be 6.5mm (see 4-6).

4-4 Position of the points of the lower knives

When the loopers are at the extreme left end of their travel, move lower knives E to the left and then make sure the points of lower knives E are 0.7mm above the blades of the loopers.

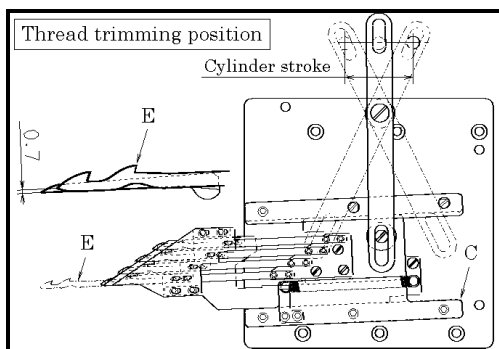

4-5 Relationship between the lower knives and the needles

On DX9902-3U/UTC

When lower knife E is at the extreme left end of its travel, adjust distance (a) from needle thread cutting edge F to the center of the left needle by referring to the table below.

Adjust distance (a) by moving lower knife drive lever L to the left or right and then fasten collar A.

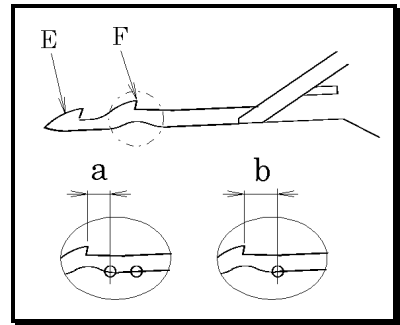

On DX9900-4U/UTC

Adjust distance (b) from the thread cutting edge to the center of the needle by following the procedure stated above.

Gauge	Distance	
	a	b
4.8-10-10-10	4.0mm	
5.0-13-13-13	3.8mm	
9.5-9.5-9.5		6mm
8.5-8.5-8.5		6mm
6.4-6.4-6.4		6mm

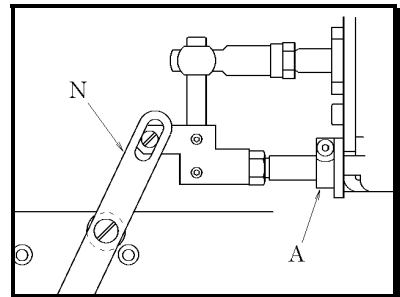

4-6 Relationship between the upper and lower knives

Check to make sure positions G on lower knives E are aligned with positions I on upper knife H.

Each distance between the points of the lower knives should be 6.5mm.

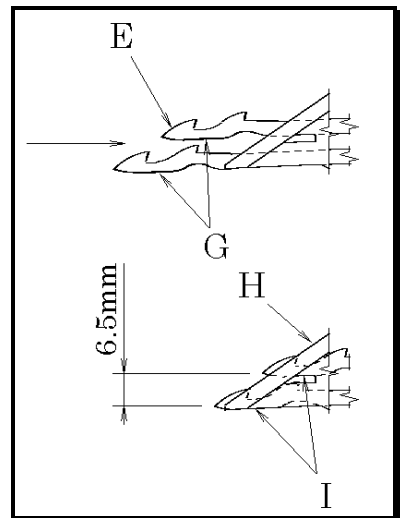

4-7 Overlap of the upper and lower knives

Loosen screws J. Then adjust each looper thread cutting edge Y by referring to the cutting edge of upper knife H as shown in the illustration below (see 4-6).

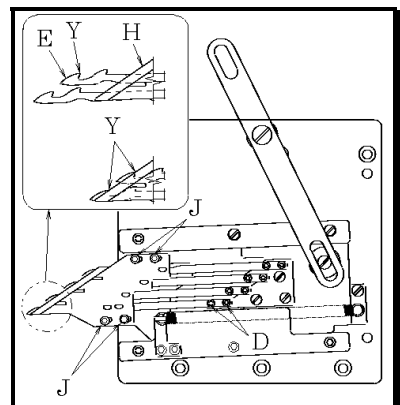

4-8 Adjusting the leaf springs

Loosen screws D and remove lower knives E.

The left-to-right position of leaf springs K varies according to the gauge. Adjust this position by referring to the illustration and the table below.

Align positions L on leaf springs K with positions I on upper knife H. Tighten screws M.

After this adjustment has been made, replace lower knives E (see 4-7).

Gauge	Distance A
4.8-10-10-10	3.4mm
5.0-13-13-13	4.1mm
9.5-9.5-9.5	3.3mm
8.5-8.5-8.5	3.0mm
6.4-6.4-6.4	3.0mm

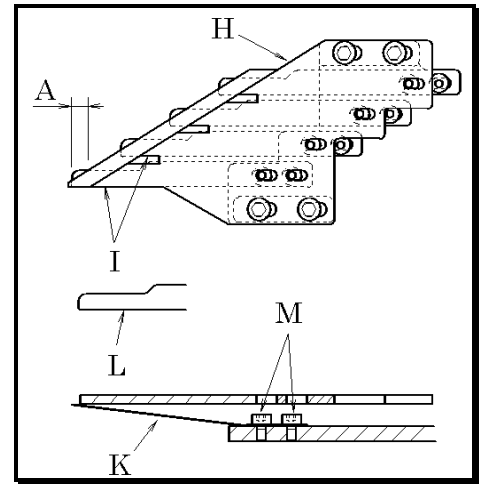

4-9 Relationship between lower knives, needle threads and looper threads

After all the adjustments have been completed, confirm the following to thread and start the machine.

Lower knife E should enter the needle thread loop(s).

Looper thread cutting edge Y should travel in front of the loop thread.

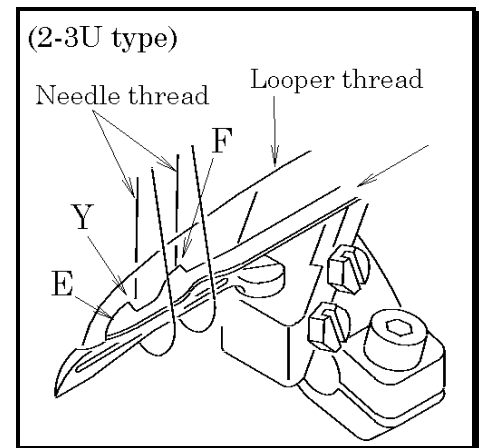
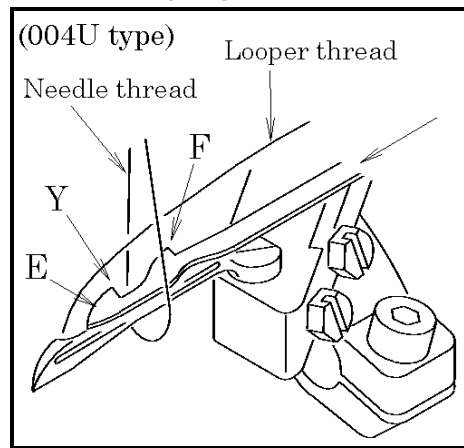

When lower knife E returns home, the needle and looper threads are hooked by their cutting edges F and Y and pulled to the right. Then they are trimmed by the upper knife.

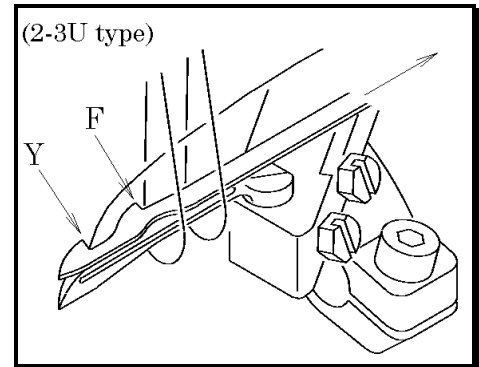
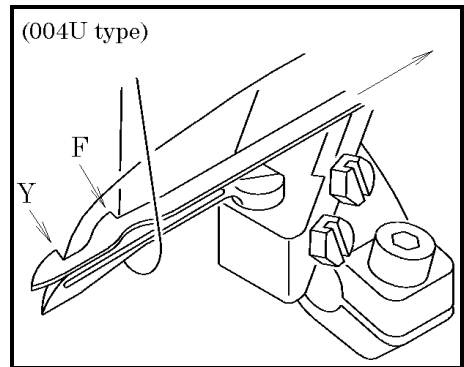

【5】 ADJUSTING THE THREAD RELEASER

5-1 Thread releaser lever

When thread releaser cylinder H gets activated, the thread tension disks should open as soon as possible. Adjustment is made by positioning thread releaser lever I. After the adjustment tighten screw J (located behind the arm) for the thread releaser lever.

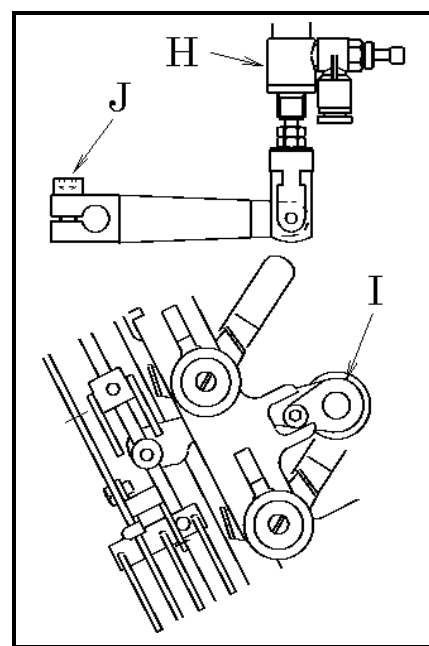

5-2 Thread releaser plate

Adjust the position of thread releaser plate G so that the tension disks will open as soon as possible.

To make this adjustment, install thread releaser bar A to thread releaser bar connection plate F with screw E. The top end of thread releaser bar A should protrude 50mm from the top surface of thread releaser bar guide B. There should be a clearance of 4mm between E ring K and thread releaser bar guide B.

5-3 Thread releaser hook

The needle threads should not protrude long from the back side of the fabric at the start of sewing.

Loosen screw C and adjust the position of thread releaser hook D. To decrease the amount of the threads to be supplied, raise the thread releaser hook.

To increase the amount of the threads to be supplied, lower the thread releaser hook. Note that the stitches are not formed at the start of sewing if the amount is too little.

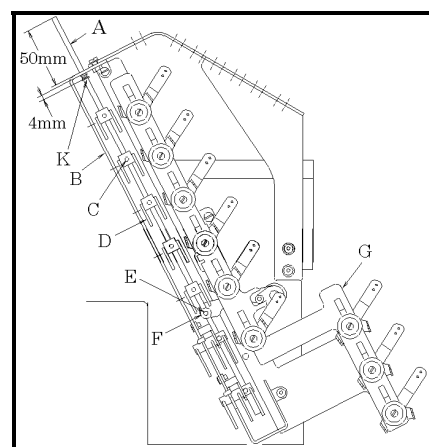

【6】 SAFETY DETECTOR

The safety detector is included so that the machine will not start running until the thread trimmer cuts the threads and returns home safely.

Switch A must be kept pressed (ON) during sewing (with the thread trimmer completely returned home).

Adjustment is made by loosening screws B and E and moving brackets C and D.

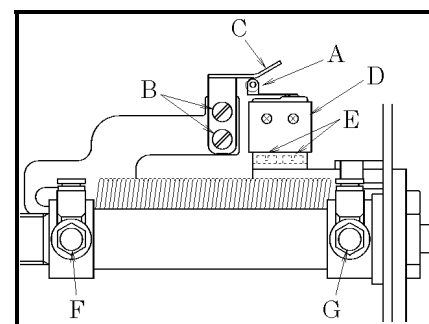

【7】 ADJUSTING THE SPEED CONTROLLER AND AIR PRESSURE

Speed controller F controls the speed when the thread trimming knife carriers protrude.
 Speed controller G controls the speed when the thread trimming knife carriers retract. If the screw for F is too loosened, the carriers will protrude too fast and then the position of the lower knives will become unstable, causing cutting error. If the screw for G is too loosened, the carriers will retract too fast and then the looper threads may not be held properly. The speed controllers are factory-set (see the illustration in [6]).

*< Note >
 Set the regulator at 4~5kgs/cm². To decrease the pressure, turn the adjusting knob clockwise. Too fast speed will give a shock to the knife carriers. Then the threads will be cut before they are cut by the knives or the threads will not be held properly. It may cause trouble.*

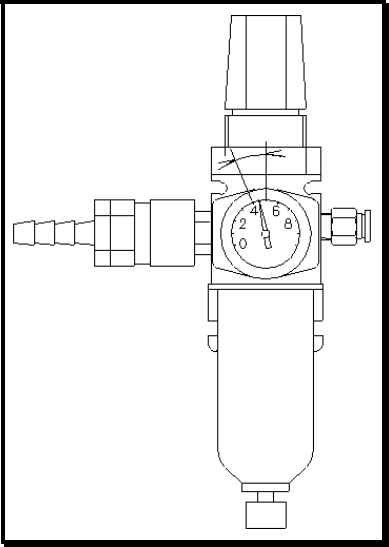

【8】 ADJUSTING THE PRESSER FOOT LIFT

The foot lift should be 7mm above the top surface of the needle plate. To make this adjustment, loosen screw D for crank lever C and then set the clearance between slot A on the presser bar clamp connection plate and screw B at 0.5~1mm.

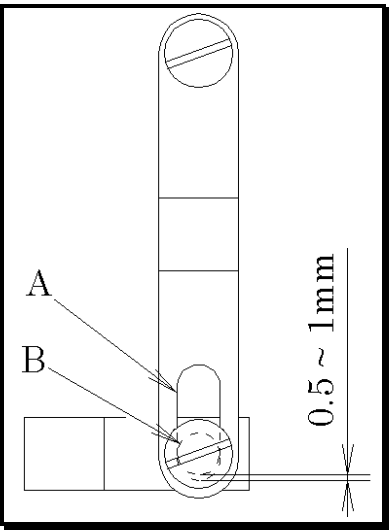
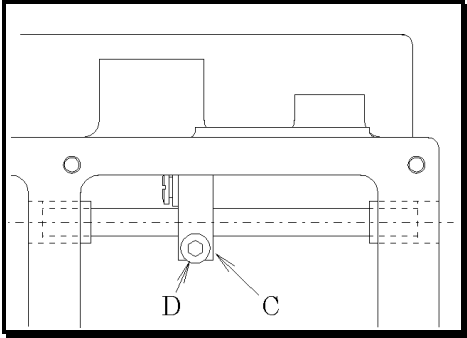

When the air cylinder on the pneumatic presser foot lift gets actuated, the presser foot lift should be 7mm above the top surface of the needle plate.
 To make this adjustment, position stopper E so that lever G cannot be lowered. After stopper E has been positioned, secure stopper E with nut F.

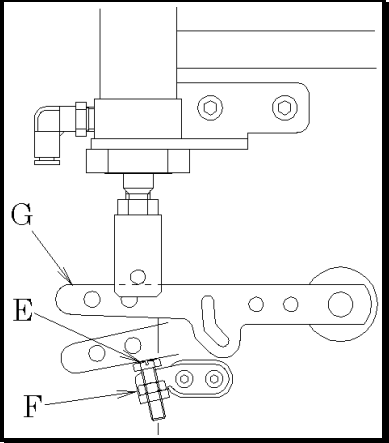

【9】 ADJUSTING THE AIR BLOWER

When the needles are at the top of their stroke, set air blower C so that air blower outlet A is 1~2mm below the center of the left needle's eye.

Adjustment is made by loosening screws B.

Adjust the amount of air with speed controller D.

The amount should be as little as possible.

Turning the adjusting screw clockwise decreases the amount. Turning the adjusting screw counterclockwise increases the amount. The air must blow through behind the needles. If the air blows through in front of the needles, it may cause the needle threads to be removed from the needles.

< Note >

The air blowing time is factory-set at 1.5 sec's.

Therefore remove the fabric from the machine as soon as the threads are cut and the presser foot is raised.

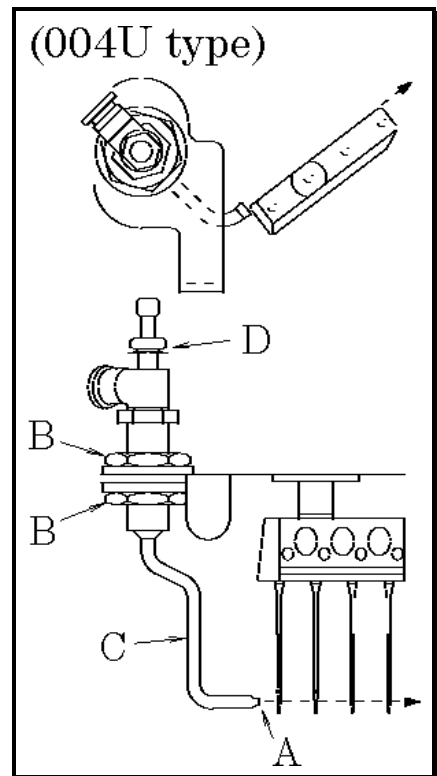
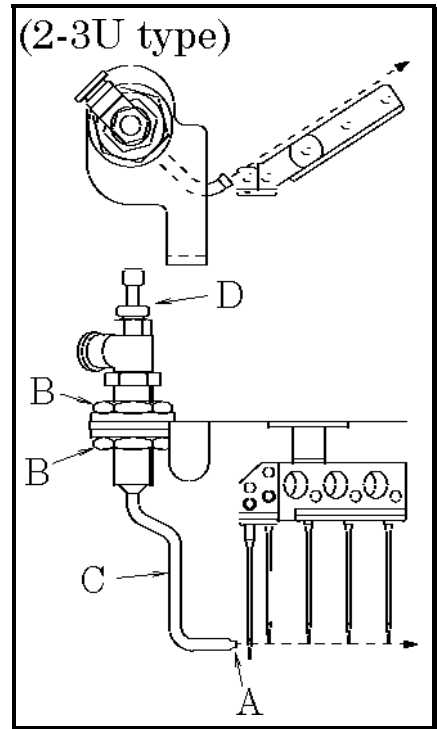

【10】CONNECTING AIR LINES AND CORDS FOR PNEUMATIC DEVICES

10-1 DX004U

Connect air lines and cords by referring to the illustration below and the parts list.

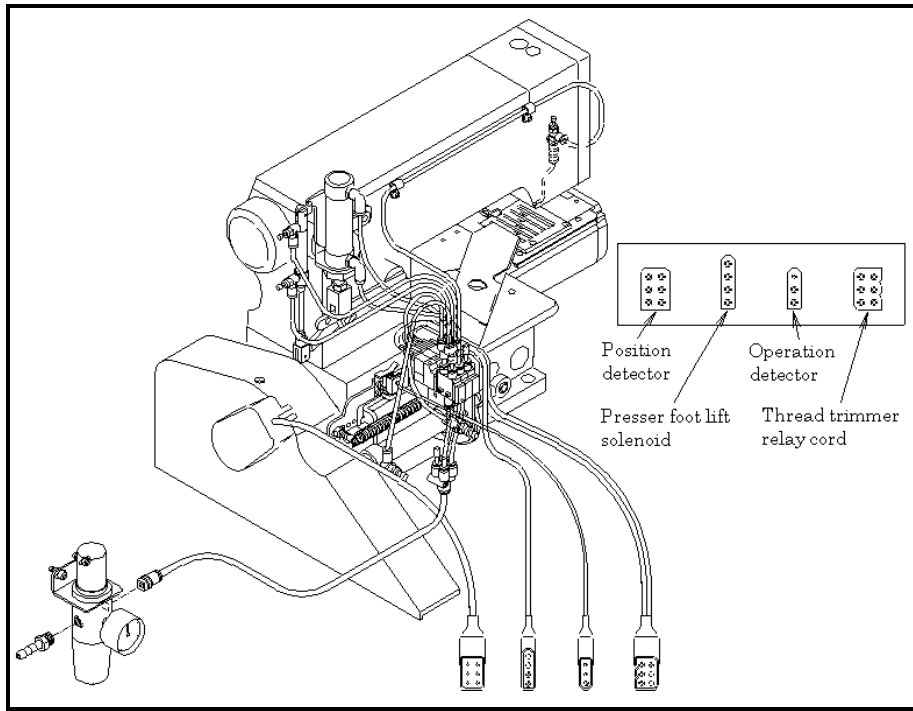

10-2 DX2-3U

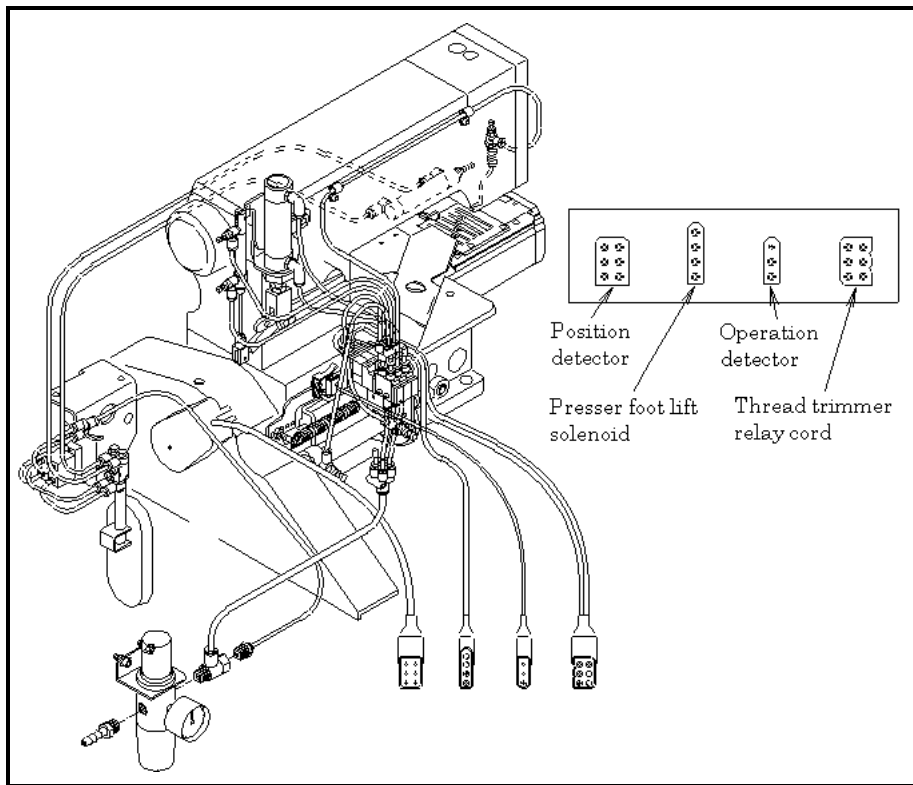

10-3 DX2-3U/LK

