

INSTRUCTION

BX SERIES

Industrial Sewing Machines

BX1425P, PSM, PTV
BX1433P, PSM, PTV
BX1025P, PSM
BX1033P, PSM

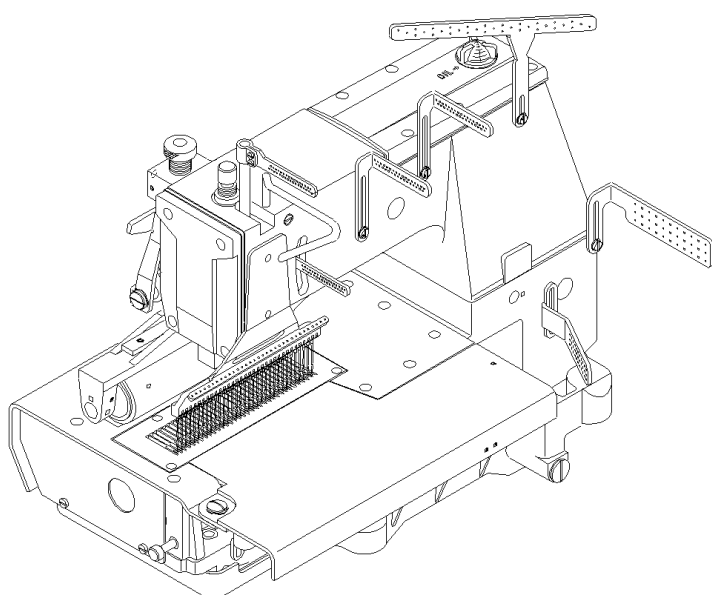

First published : November 1997

No. 970112

KANSAI
SPECIAL®

INTRODUCTION

Thank you for your purchasing Kansai Special's BX Series.

Read and study this instruction manual carefully before beginning any of the procedures and save it for later use.

1. This instruction manual describes adjustments and maintenance procedures on this machine.
2. Before starting the machine, check to make sure the pulley cover, safety cover, etc. are secured.
3. Before adjusting, cleaning, threading the machine or replacing the needle, be sure to turn off the power.
4. Never start the machine with no oil in the reservoir.
5. Refer to the parts list as well as this instruction manual before performing preventive maintenance.
6. The contents described in this instruction manual are subject to change without notice.

CONTENTS

1. SPECIFICATIONS	
1-1 Stitch type	1
1-2 Model	1
2. NEEDLES & THREADING THE MACHINE	
2-1 Needles	1
2-2 Replacing the needle	1
2-3 To thread the machine	2
3. MACHINE SPEED	
3-1 Machine speed & direction in which the machine pulley runs	9
3-2 Motor & belt	9
4. LUBRICATION	
4-1 Oil	10
4-2 To fill the machine with oil	10
4-3 Replacing the oil and the filter element	10
5. SEWING MACHINE INSTALLATION	
5-1 Cutting the machine table	11
5-2 How to install the machine	12
6. TIMING OF THE LOOPER TO THE NEEDLES	
6-1 Angle for installing the looper and position of the looper holder bracket	12
6-2 Looper left-to-right movement	13
6-3 Looper setting distance	13
6-4 Needle height	14
7. ADJUSTING THE TIMING OF THE RETAINER LOOPER	
7-1 Position of the retainer looper	14
7-2 Timing of the retainer looper to the needle	15
8. ADJUSTING THE NEEDLE GUARD	
8-1 Position of the needle guard	15
9. ADJUSTING THE FEED DOG & STITCH LENGTH	
9-1 Feed dog height & tilt	15
9-2 Stitch length	16
10. ADJUSTING THE PRESSER FOOT	
10-1 Presser foot pressure	16
10-2 Position of the presser foot	16
11. ADJUSTING THE REAR PULLER DEVICE	
11-1 Manual lever	17
11-2 To adjust the puller pressure	17
11-3 Adjusting the feeding amount of the rear puller	17
12. ADJUSTING THE STITCH FORMATION	
12-1 Thread tension adjustment	17
12-2 Position of the needle thread eyelets	17
12-3 Adjusting the needle thread guard	18
12-4 Position and timing of the looper thread eyelet	18
13. PSM MECHANISM	
13-1 Types of cams	18
13-2 Producing decorative stitches	19
13-3 Replacing the cams	21
13-4 Timing of spreaders	21
13-5 Adjusting the spreaders	22
14. PTV MECHANISM	
14-1 Disassembling and reassembling the binder	22
14-2 Adjusting the binder up and down	23
14-3 Position of the upper and lower fingers of the binder	23
15. CLEANING THE MACHINE	23

【1】 SPECIFICATIONS

1-1 Stitch type

JIS401 double chainstitch machines

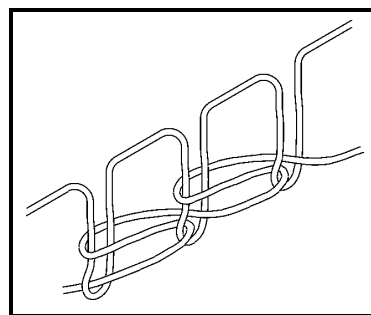

1-2 Model

Model	BX1433	BX1033 (single chainstitch)
No. of needles	33 (Maximum)	
No. of threads	33 needle threads (Maximum)	
	33 looper threads	
Type of tension set	Separate type	
Puller width	165mm	
Minimum gauge width	4.76mm (3/16 inch)	
Maximum gauge width	152.4mm (6 inch)	

【2】 NEEDLES & THREADING THE MACHINE

2-1 Needles

UO113GS of Schmetz or Organ

Select the proper needle for the fabric and thread.

< Needles and needle size >

Schmetz	Nm75	Nm80	Nm90	Nm100	Nm130
Organ	# 11	# 12	# 14	# 16	# 21

	Organ	Schmetz
1433P	UO x 113	UY x 113
1033P	DV-K25	
PSM	DV x 57	DV x 57
PTV	DV x 57	DV x 57

2-2 Replacing the needle

When replacing the needle, check the needle carefully to see that the scarf is turned to the left of the machine (see the illustration).

< Note >

When replacing the needle, be sure to turn off the machine. A clutch motor continues running for a while after the machine is turned off.

Therefore keep on pressing the pedal until the machine stops.

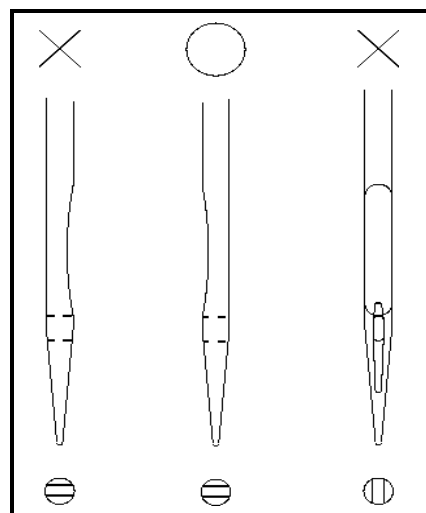

2-3 To thread the machine

Thread the machine correctly by referring to pages 3 to 8.

Incorrect threading may cause skip stitching, thread breakage and/or uneven stitch formation. When threading the looper, tilt the looper holder toward the front of the machine using the looper drawing bar.

To tilt the looper toward the front

1. Bring needle bar A to the top of its stroke.
2. Pay out the needle thread from the spool by pressing a finger down on needle threads B.
3. Pull looper drawing bar knob C out to the left so that the looper holder is tilted toward the front of the machine.
4. After the machine is threaded, replace the looper by pressing looper holder D into the machine until it clicks.

< Note >

The looper pops out of the machine as soon as knob C is pulled, so do not bring your fingers close to the looper.

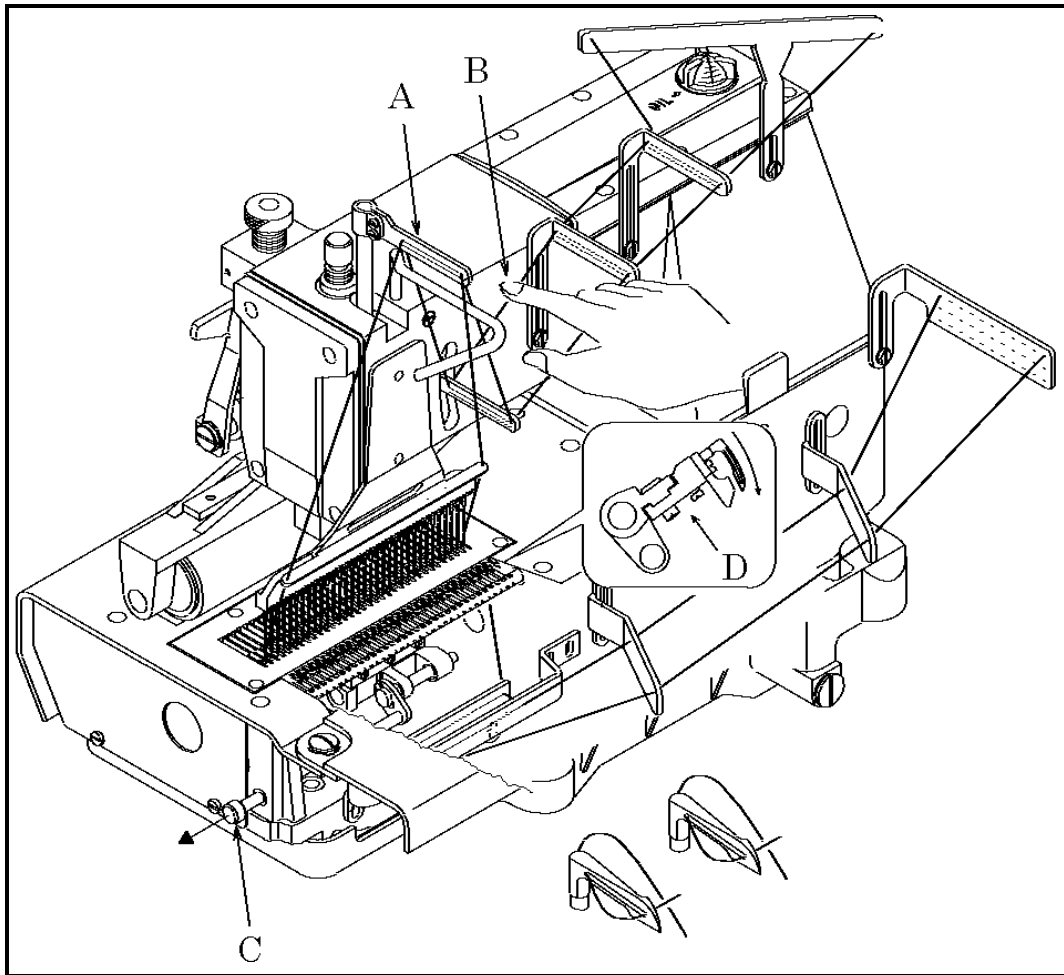

Threading diagram for BX1425P

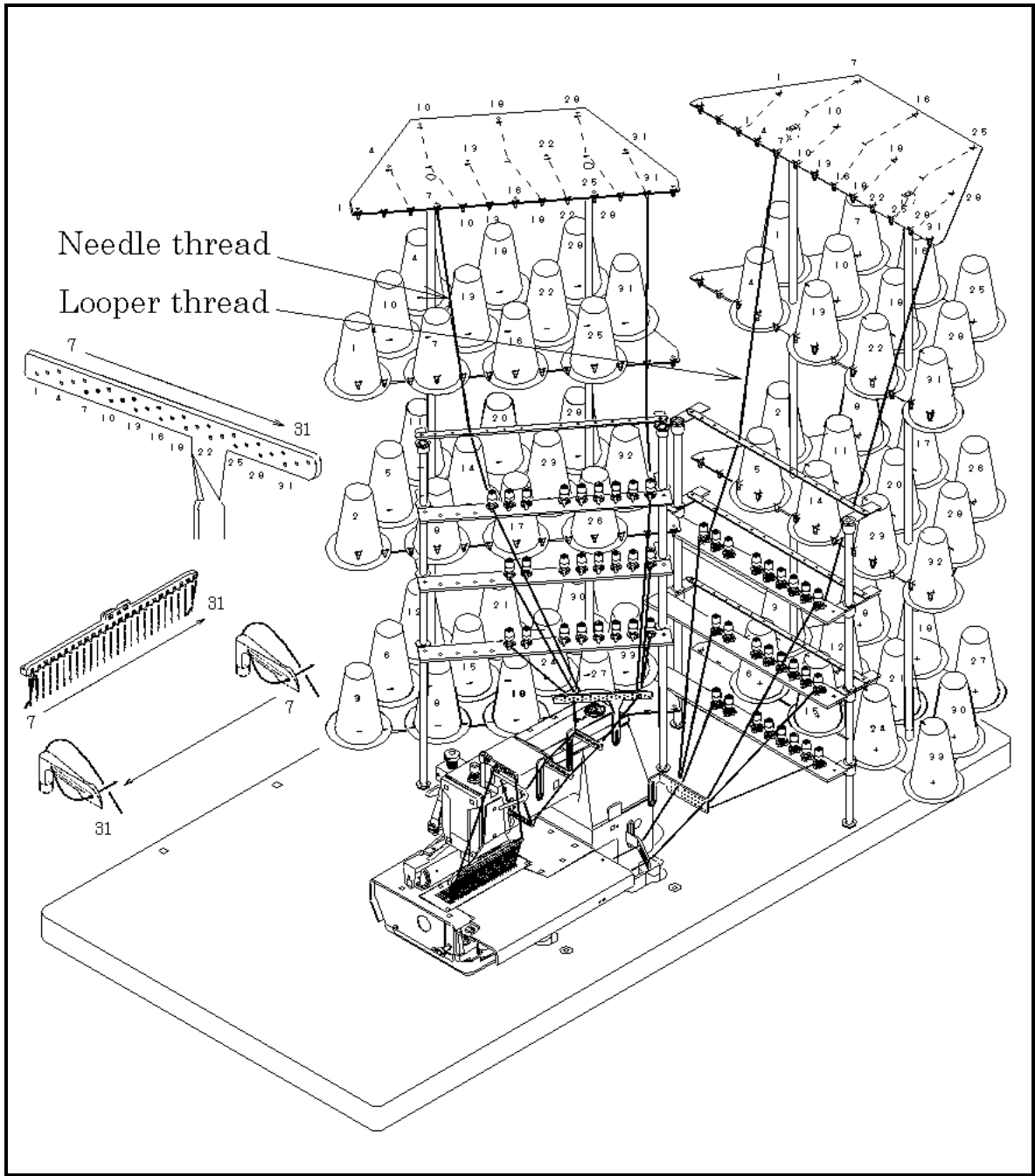

Threading diagram for BX1433P

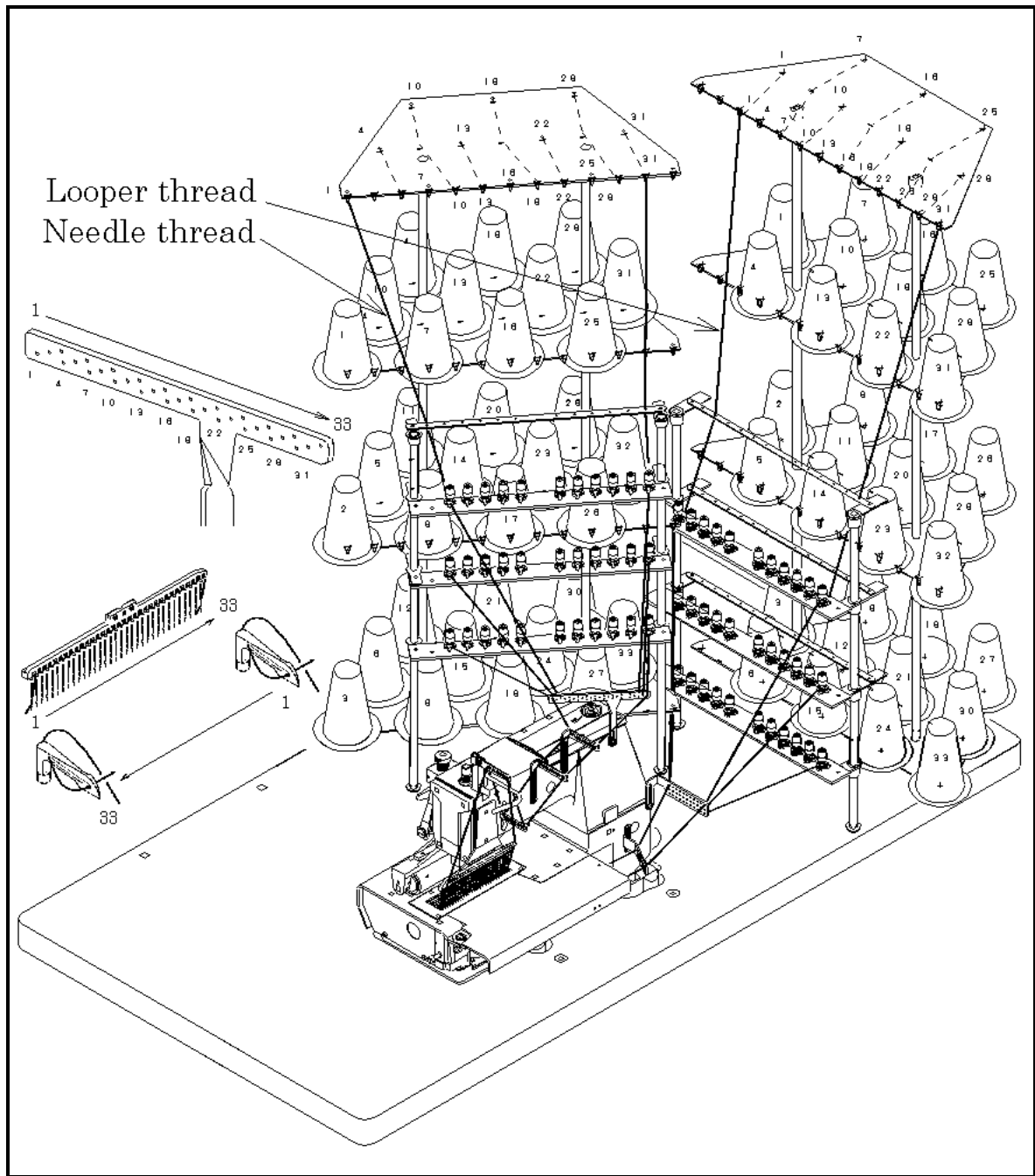

Threading diagram for BX1025

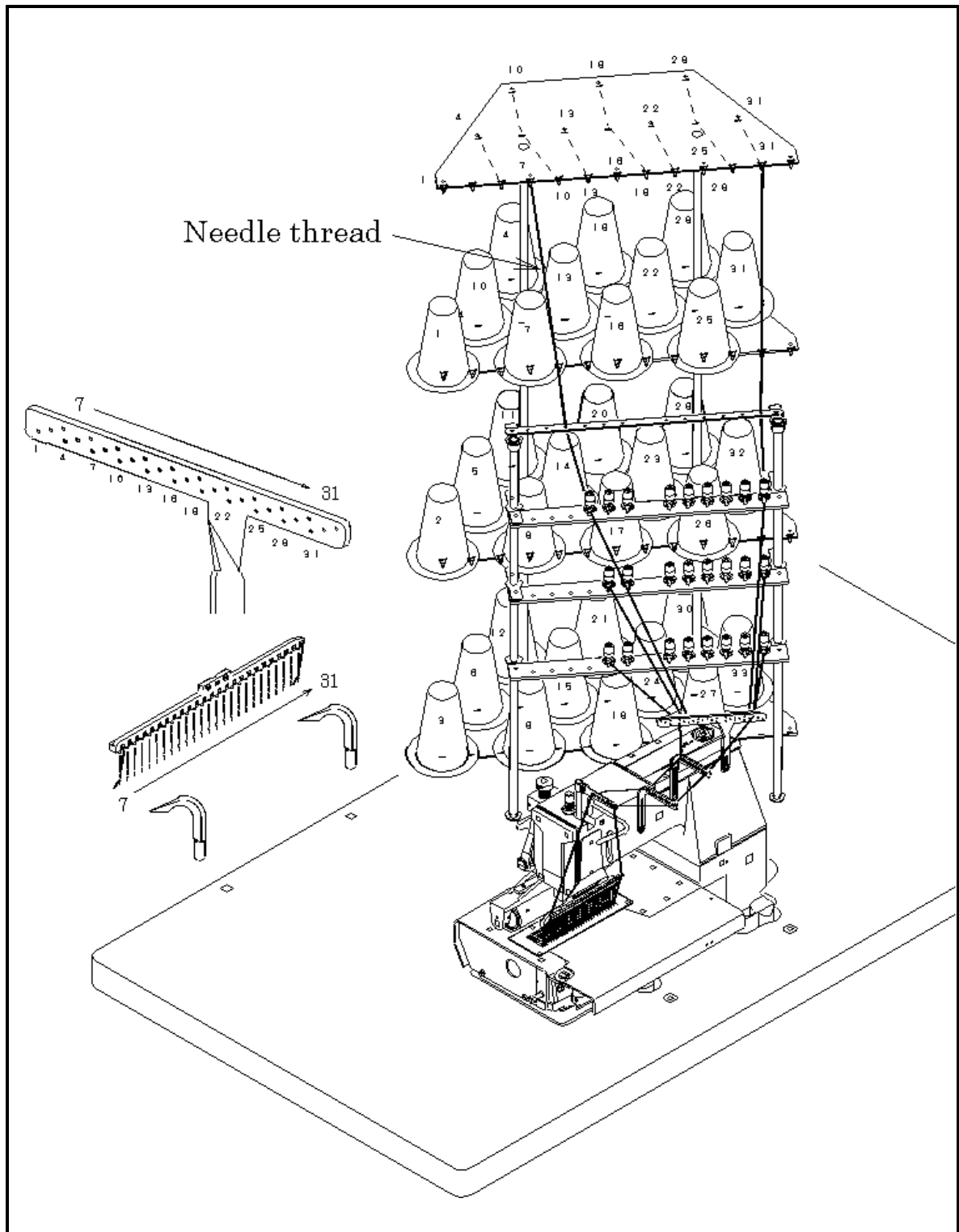

Threading diagram for BX1033

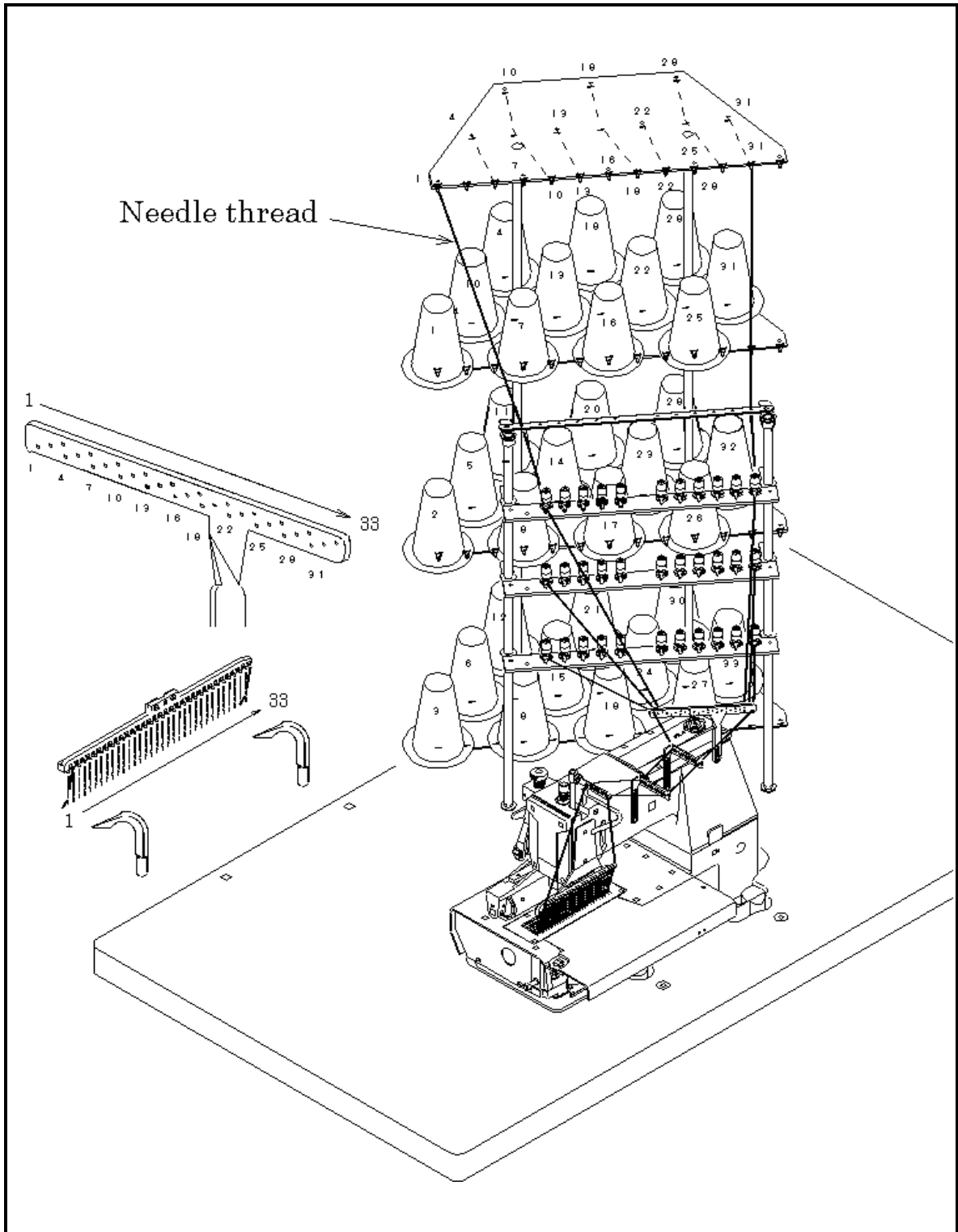

Threading diagram for BX1425PSM

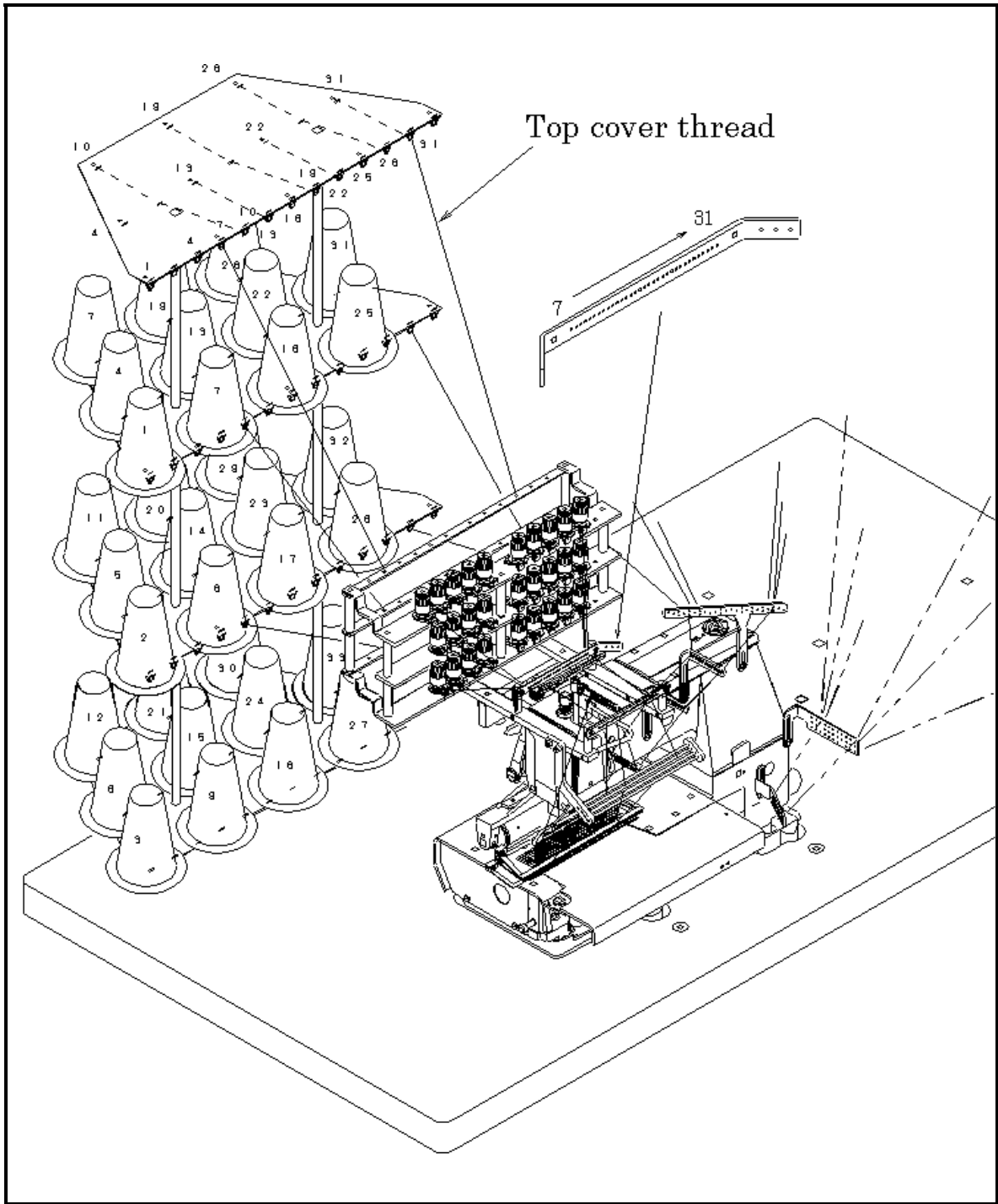

Threading diagram for BX1433PSM

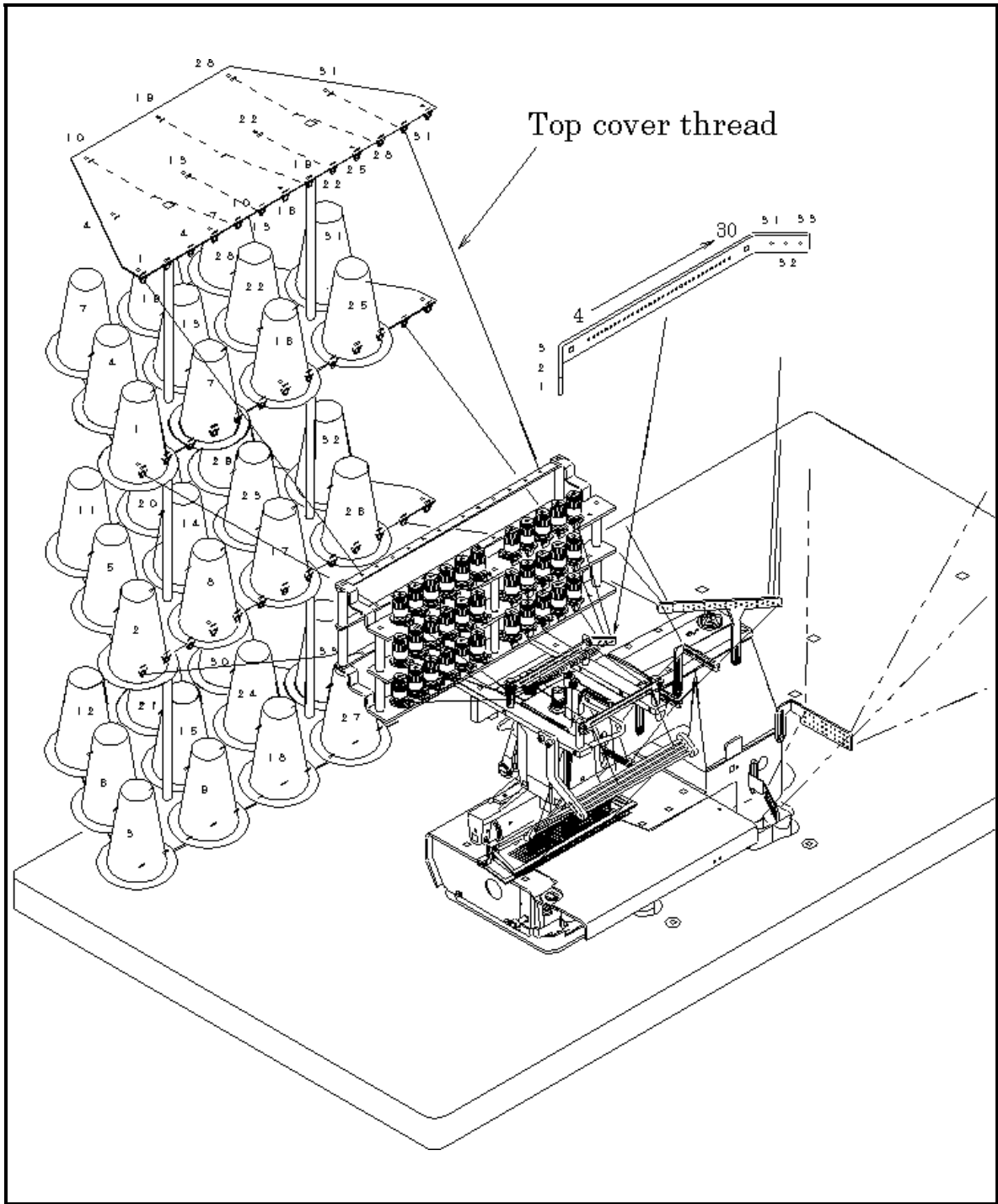

【3】 MACHINE SPEED

3-1 Machine speed & direction in which the machine pulley runs

Refer to the table below for maximum and standard speeds of the Series. To extend machine life, run the machine approximately 15~20% below the maximum speed for the first 200 hours of operation (approx. 1 month). Then run the machine at the standard speed. The machine pulley turns counterclockwise as seen from the end of the machine pulley.

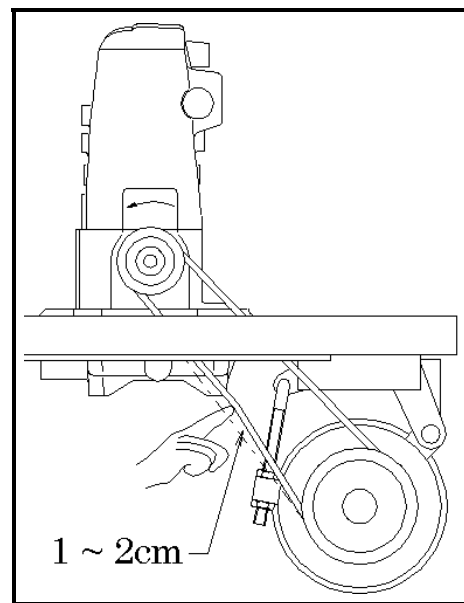

3-2 Motor & belt

Motor : 3-phase, 2-pole, 400W clutch motor

Belt : M type V belt

Select the proper motor pulley according to the machine speed (refer to the motor pulley outer diameter on the table below).

Adjust the position of the motor by pressing the finger onto the middle of the belt so that 1~2cm deflection can be achieved (see the illustration on the right).

< Machine speed >

Model	Maximum speed	Standard speed
BX1433	2500	2000
BX1033	2500	2000
PSM	2000	1500

< Motor pulley selection table >

Motor pulley outer diameter (mm)	Machine speed (SPM)	
	50Hz	60Hz
30	1250	1450
40	1650	1950
50	2050	2450
60	2500	2950
70	2900	3450

【4】 LUBRICATION

4-1 Oil

Use Kansai Special's genuine oil.
(Part No. 28-611)

4-2 To fill the machine with oil

Remove oil pot A.

Fill the machine with oil until the oil level is at the top line (see H in the illustration) on oil gauge C.

After the first lubrication, add oil so that the oil level will be between H and L.

After filling the machine with oil, run the machine to check the oil is splashing onto oil pot A.

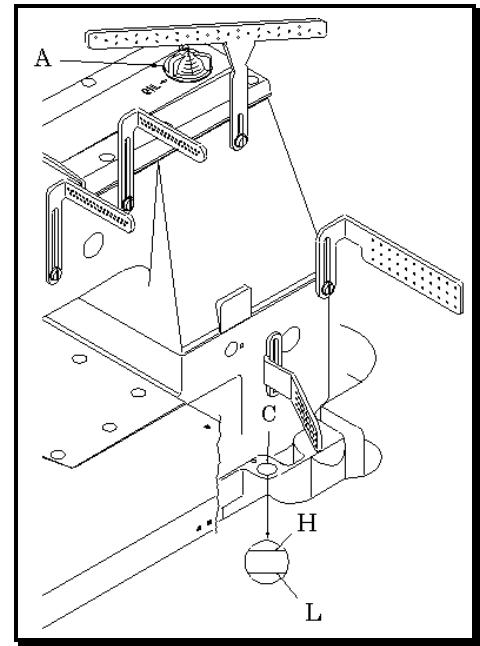

4-3 Replacing the oil and the filter element

To extend machine life, be sure to replace the oil after the first 250 hours of operation.

To replace the oil, follow the procedures below.

1. Remove the V belt from the motor pulley and then remove the machine from the table.
2. Remove screw D and then drain the oil. Be careful not to stain V belt with the oil.
3. After draining the oil, be sure to tighten screw D.
4. Fill the machine with oil by referring to 4-2 shown above.

If filter element E is contaminated, proper oiling may not be performed. Clean the filter element every six months. If just a little or no oil flows out from the nozzle with the proper amount of oil in the machine, check the filter element. To clean the filter element, remove oil filter cap F.

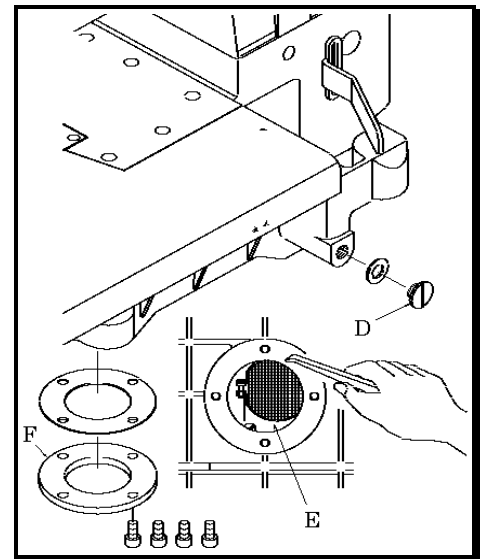

【5】 SEWING MACHINE INSTALLATION

5-1 Cutting the machine table

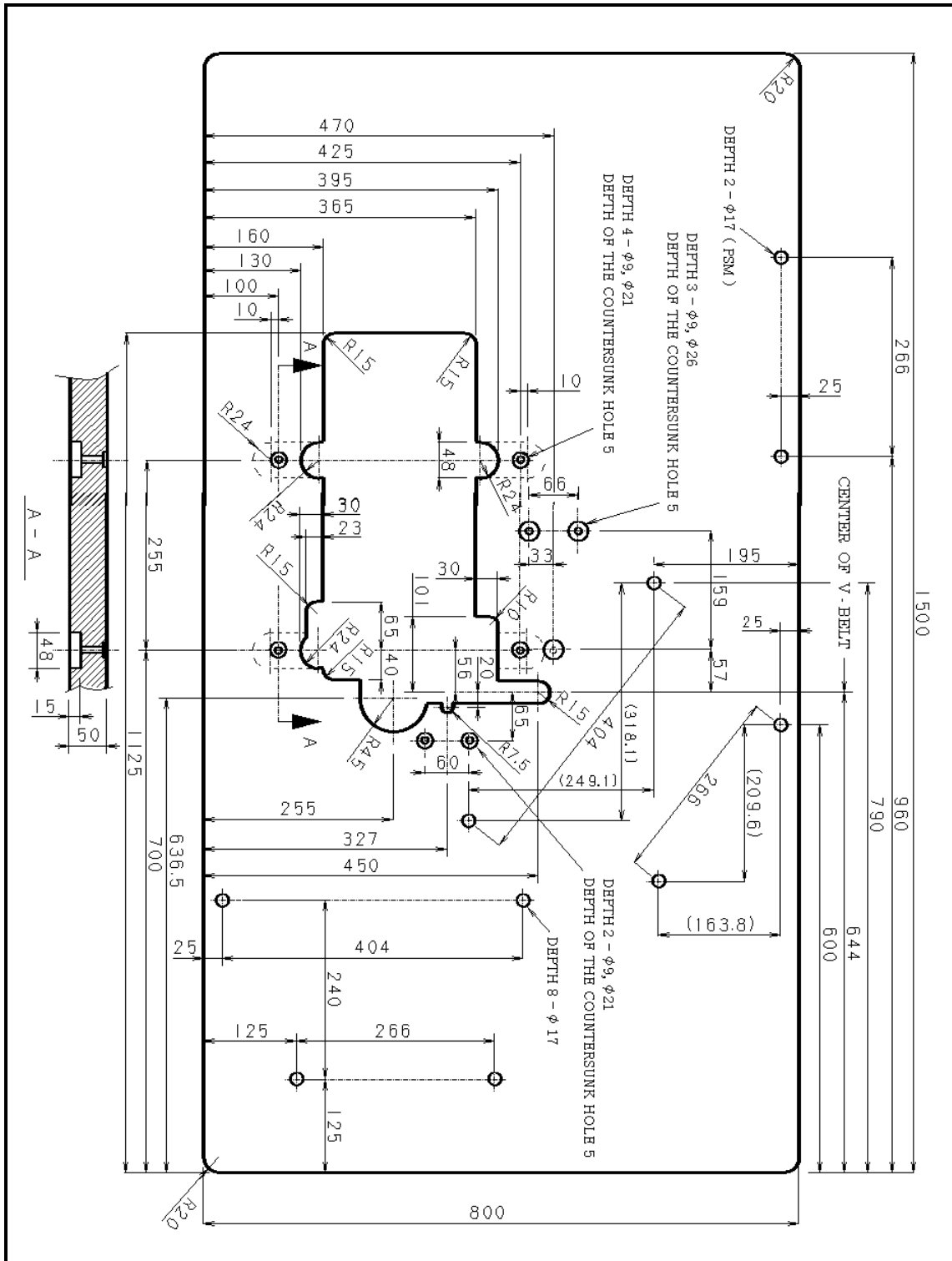

5-2 How to install the machine

Install the brackets on the underside of the table board (see the illustration below).
Fit the rubber cushions onto the brackets.
Mount the machine head on the rubber cushions.

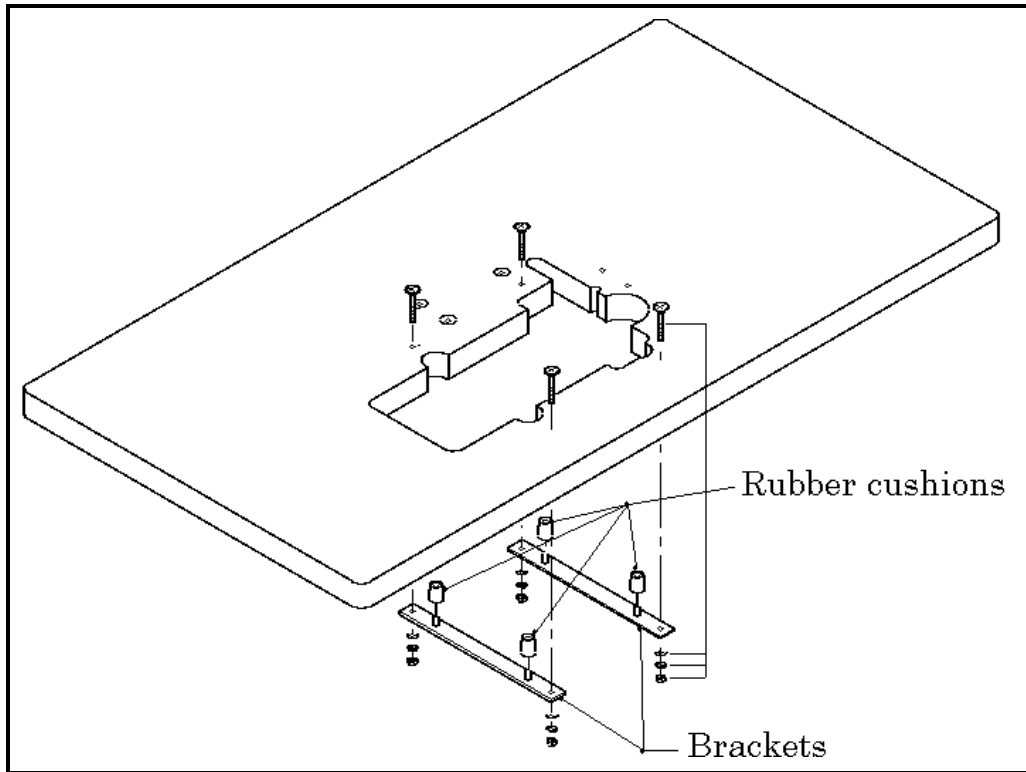

【6】TIMING OF THE LOOPER TO THE NEEDLES

6-1 Angle for installing the looper and position of the looper holder bracket

Insert the looper into the looper holder until bottom A of the looper touches looper holder bracket B. Then tighten screw C. When the looper passes the needle, there should be a clearance of 0~0.1mm between the point of the looper and the scarf of the needle.

Adjustment is made by loosening screw D and moving the looper holder bracket left or right.

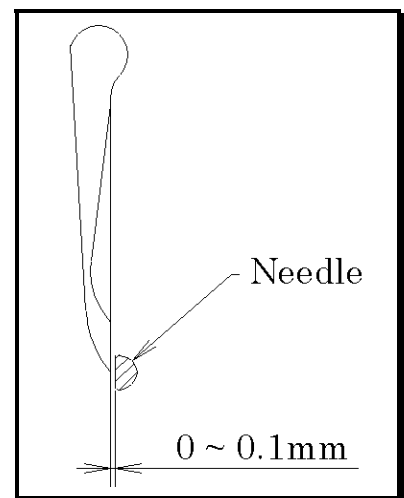
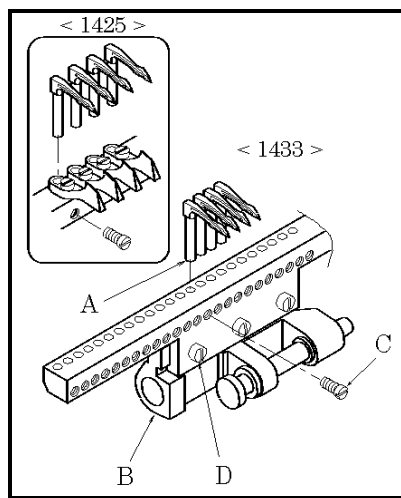

6-2 Looper left-to-right movement

When the looper passes the needle, the point of the looper, moving to the right, should be 1.5mm above the top of the needle's eye.

When the looper passes the needle, the point of the looper, moving to the left, should be 3mm above the top of the needle's eye.

For single chainstitching, when the looper enters the needle thread loop, the point of the looper should be 4mm above the top of the needle's eye.

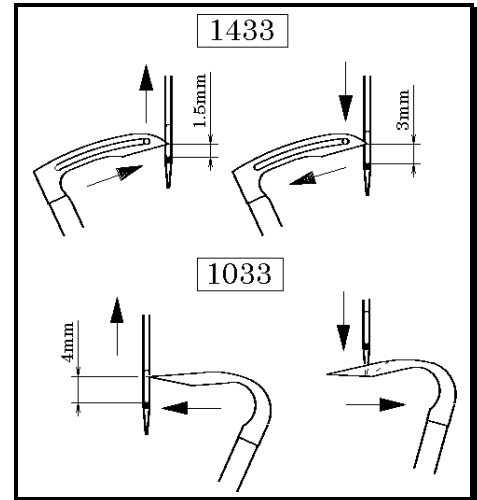

To make this adjustment, remove the cover first, loosen eccentric set screw D and then move eccentric ball A.

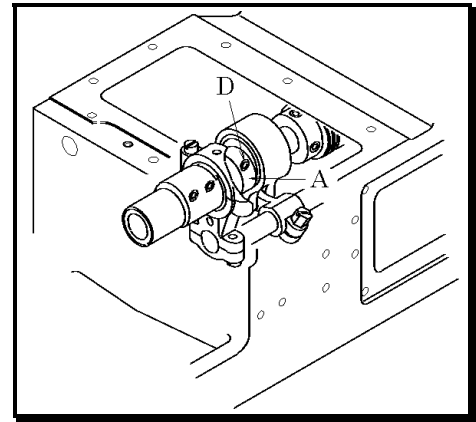

6-3 Looper setting distance

When the needle bar is at the bottom of its stroke, the distance from the point of the looper to the center of the needle should be 3mm. For single chainstitching, the distance should be 1.8mm.

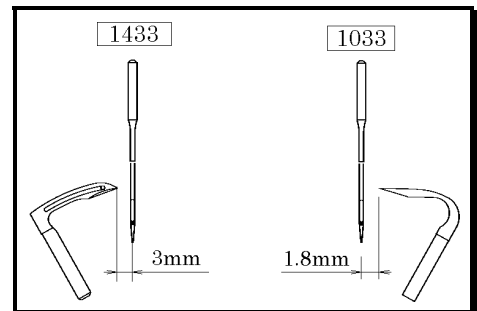

Adjustment is made by removing the cover and loosening screw B on looper front-to-back lever A.

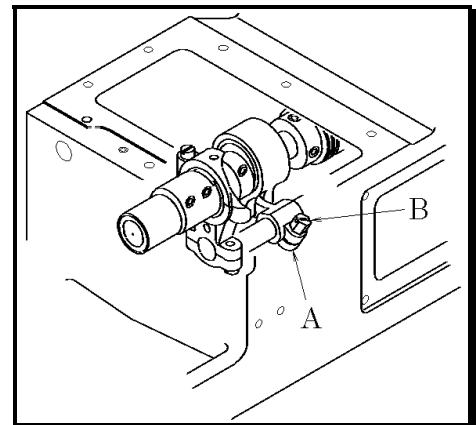

6-4 Needle height

When the needle bar is at the top of its stroke, remove side cover plate A, loosen screw C on needle bar clamp B with a hexagonal wrench and then move the needle bar up or down as required.

< Standard needle bar height D >

Stroke	Standard model
34mm	13.5mm

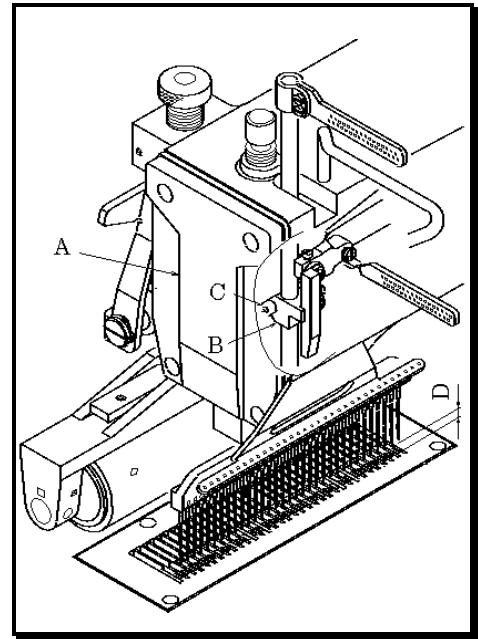
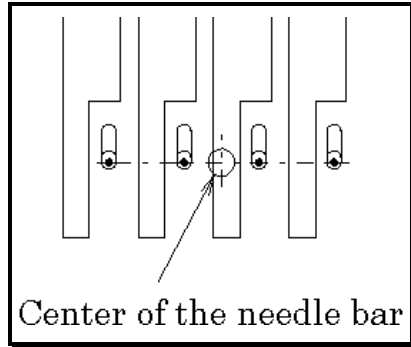

< Note >

After the above adjustment is made, check to make sure each needle drops correctly into the center of each needle drop hole.

【7】 ADJUSTING THE TIMING OF THE RETAINER LOOPER

7-1 Position of the retainer looper

Install retainer looper A so that its flat surface is turned upward.

At this time, there should be a clearance of 0.5mm between the needle and the point of the retainer looper. Adjustment is made by loosening B.

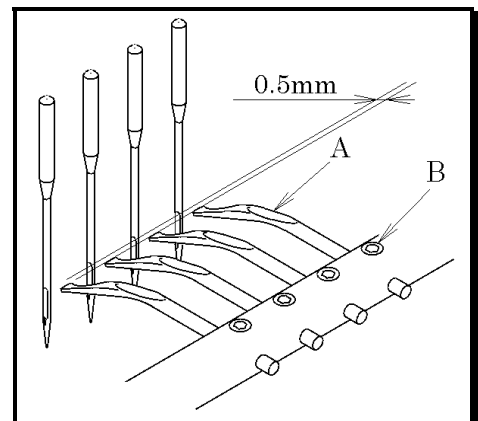
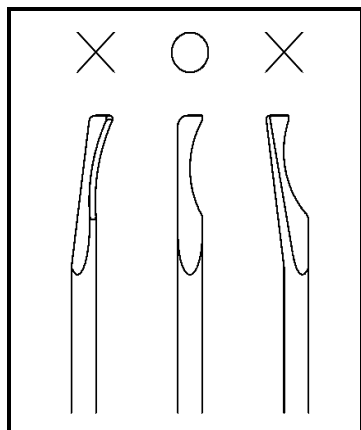

7-2 Timing of the retainer looper to the needle

When the needle, moving from the top to bottom of its stroke, enters the triangle of the looper thread, the retainer looper should be at the extreme right end of its travel.

To adjust the retainer looper left to right, loosen screws A first. With the retainer looper at the extreme left end of its travel, set the clearance between the retainer looper and the right side of the looper at approximately 0.5mm. Then set the clearance between the retainer looper and the top surface of the looper blade at 0.1mm. After this adjustment is made, tighten screws A.

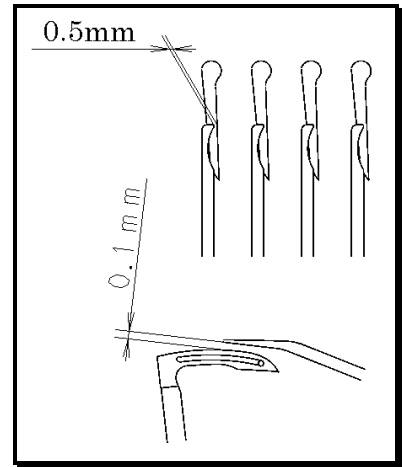
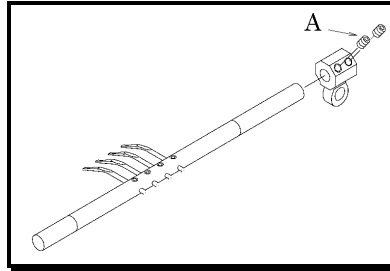

【8】 ADJUSTING THE NEEDLE GUARD

8-1 Position of the needle guard

When the needle is closest to the needle guard, there should be a clearance 0~0.1mm between the right side of the needle and needle guard A.

Adjustment is made by loosening screw B.

< Note >

To adjust the standard type of needle guard, after positioning the looper holder bracket (see 6-1) adjust the looper by loosening the looper set screw. Then tighten screw B.

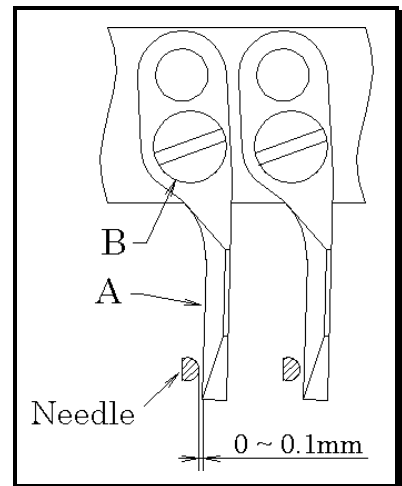

【9】 ADJUSTING THE FEED DOG & STITCH LENGTH

9-1 Feed dog height & tilt

When the needle bar is at the top of its stroke, the feed dog teeth should be 1~1.2mm above the top surface of the needle plate.

Adjustment is made by loosening screw A. Then check to see if the feed dog teeth is parallel with the top surface of the needle plate. Adjustment is made with screws B and C.

< Note >

When adjusting the height of the feed dog, tilt the looper holder toward the front of the machine.

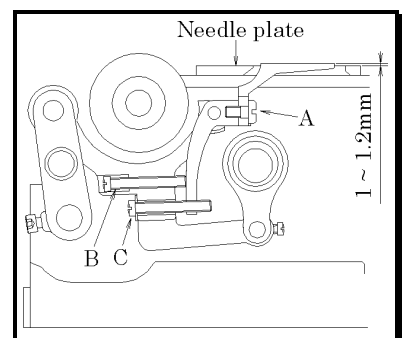

9-2 Stitch length

The stitch length can be adjusted from 2 to 5mm with no step. The following table shows the stitch length with the number of stitches within 1 inch (25.4mm) and 30mm.

Stitch length (mm)	No. of stitches	
	within 1"	within 30mm
2	13	15
3	8.5	10
5	5	6

To change the stitch length

1. Loosen nut A while checking the direction in which the nut is loosened.
2. To decrease the stitch length, turn screw B clockwise.
To increase the stitch length, turn screw B counterclockwise.
3. After this adjustment is made by turning screw B, be sure to tighten screw A.

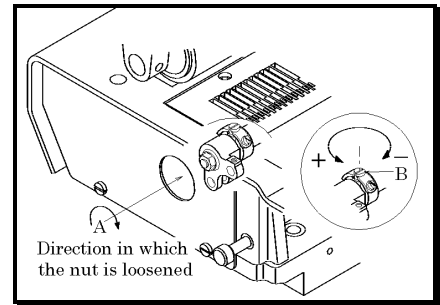

< Note >

Be sure turn off the motor when changing the stitch length.

【10】 ADJUSTING THE PRESSER FOOT

10-1 Presser foot pressure

The presser foot pressure should be as light as possible, yet be sufficient to feed the fabric and produce uniform stitches. To increase the presser foot pressure, turn the adjusting knob clockwise.

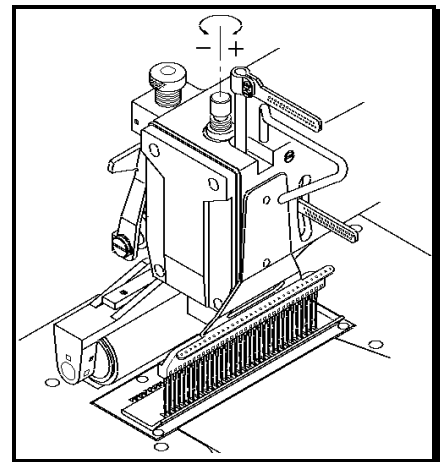

10-2 Position of the presser foot

Fit the presser foot onto the presser bar so that the needle can drop correctly to the center of the needle drop hole on the presser foot. Adjustment is made by loosening screw A. The left-to-right play adjustment on the presser foot is made by loosening nuts B. Create a clearance of 0.5mm as shown in the illustration on the right.

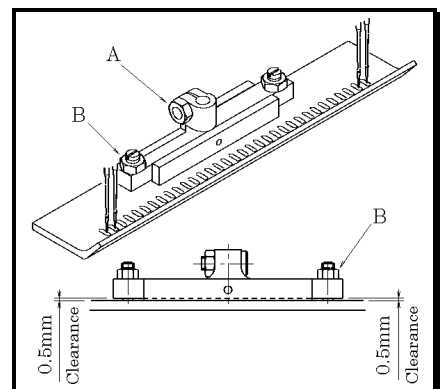

【11】 ADJUSTING THE REAR PULLER DEVICE

11-1 Manual lever

To position or remove the fabric, raise manual lever A.

11-2 To adjust the puller pressure

The puller pressure should be as light as possible, yet be sufficient to feed the fabric smoothly.

To increase the pressure, turn adjusting knob D clockwise.

To decrease the pressure, turn adjusting knob D counterclockwise.

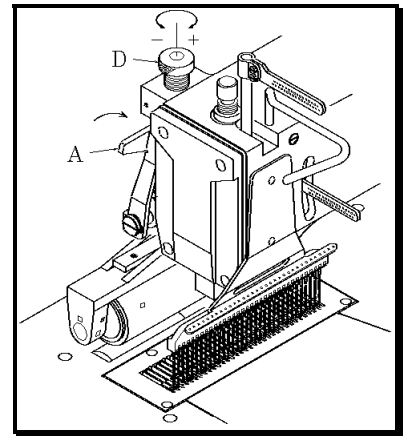

11-3 Adjusting the feeding amount of the rear puller

Adjust the feeding amount of the rear puller according to that of the feed dog. To increase the amount, loosen nut G and move it to the left. To decrease the amount, move it to the right.

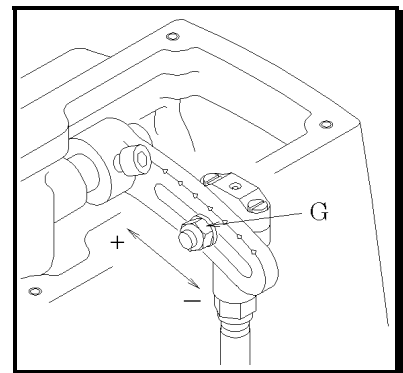

【12】 ADJUSTING THE STITCH FORMATION

12-1 Thread tension adjustment

Thread tension varies according to sewing conditions such as the fabric, thread and stitch length to be used.

Tension on the needle thread and looper thread can be adjusted with nuts A which is set-in on each thread stands.

< Note >

The tension should be as light as possible, yet be sufficient to produce uniform stitches.

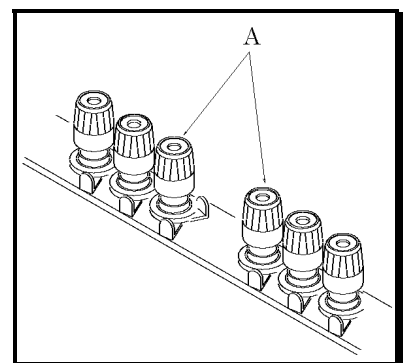

12-2 Position of the needle thread eyelets

On 1425~1433, secure needle thread eyelet C at the bottom end of the slot.

< Note >

Adjust the needle thread eyelets according to the thread to be used. To tighten the needle thread, raise the needle thread eyelets.

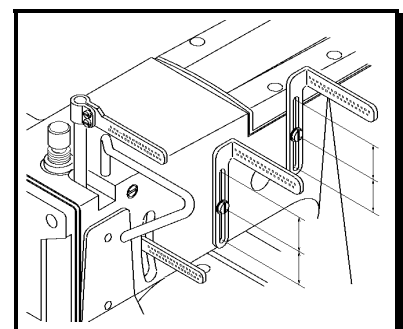

BX series

12-3 Adjusting the needle thread guard

With the needle bar at the bottom of its stroke, the top surface of needle thread guard A should be level and parallel with the centers of the eyes on needle bar eyelet B.

< Note >

Raising needle thread guard A increases the size of the needle thread loop. Lowering needle thread guard A decreases the size of the needle thread loop.

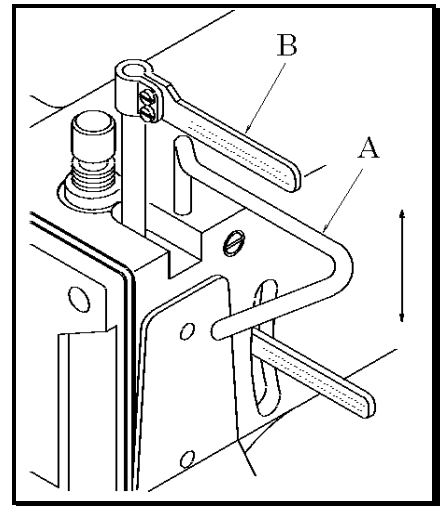

12-4 Position and timing of the looper thread eyelet

When the point of the needle has reached the underside of the looper blade while the needle bar is descending, the looper thread eyelet bar should ascend. With the looper thread eyelet bar at the bottom of its stroke, adjust distance A between the eye on the looper thread eyelet and the looper thread eyelet bar by referring to the table below.

Thread type	Distance A
Polyester (Tetoron)	8mm
Spun	10mm
Wooly	15mm

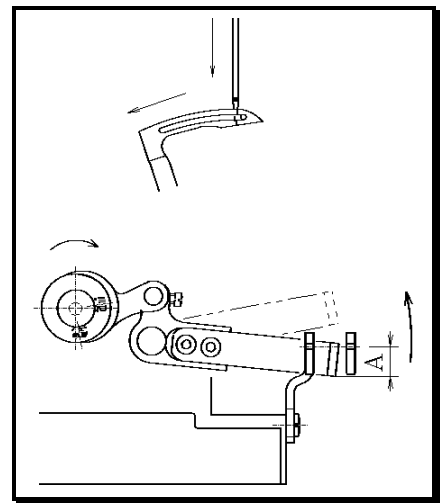

【13】 PSM MECHANISM

13-1 Types of cams

There are 9 types of cams from No.1 to No.9 (9 types of standard patterns). Various kinds of decorative stitches can be produced by a combination of 2 cams. The inside cam moves the upper spreader. The outside cam moves the lower two spreaders and crosses spreader threads.

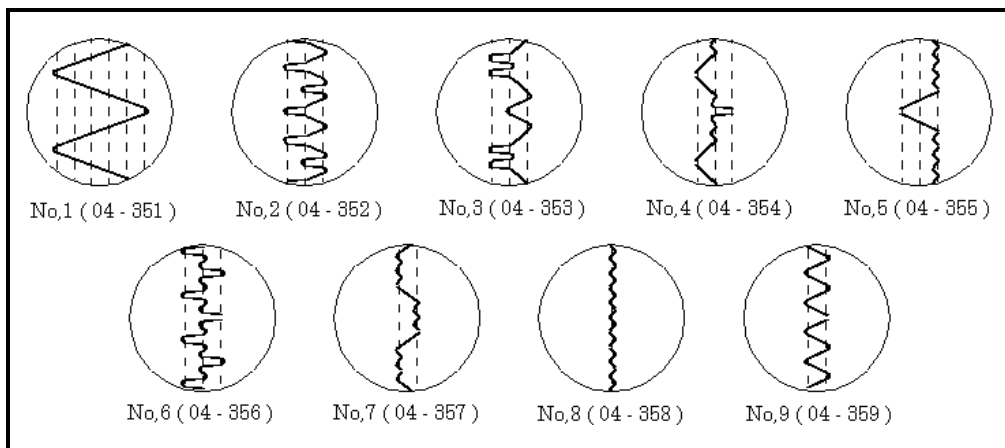

13-2 Producing decorative stitches

Install cam 1 on the outside to use the lower two spreaders. Install any one of cams No.2 to No.9 on the inside to use the upper spreader. Thread spreaders' eyes marked . Following the above procedures automatically produces the decorative stitches below (refer to decorative stitches No.2 to No.9).

No.1

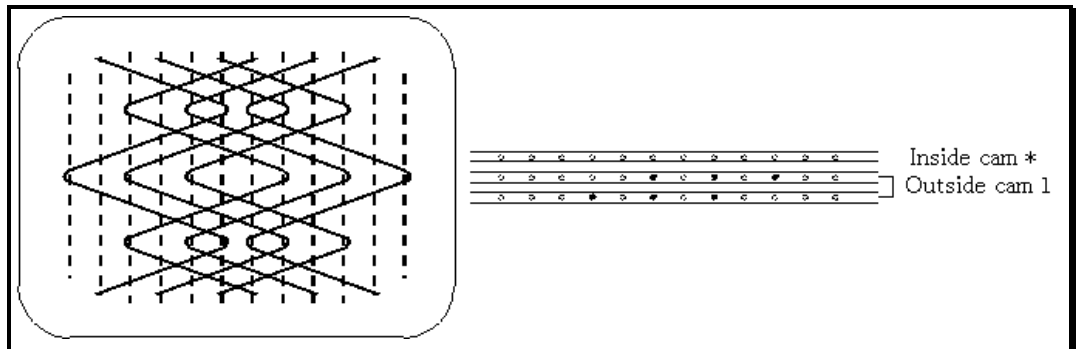

No.2

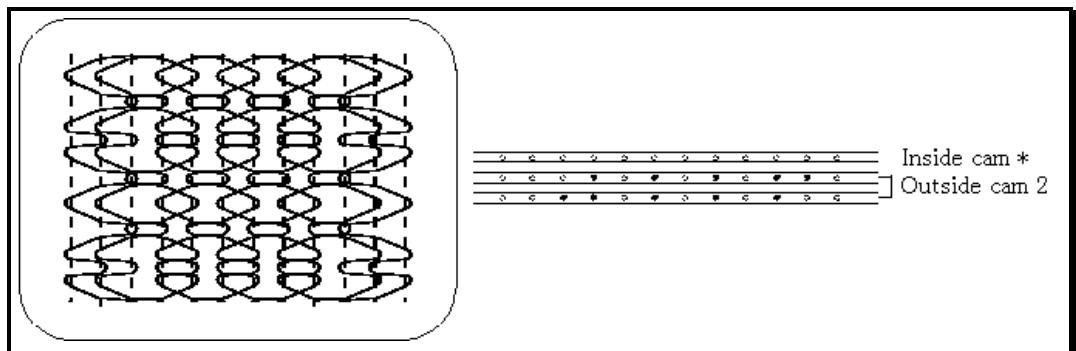

No.3

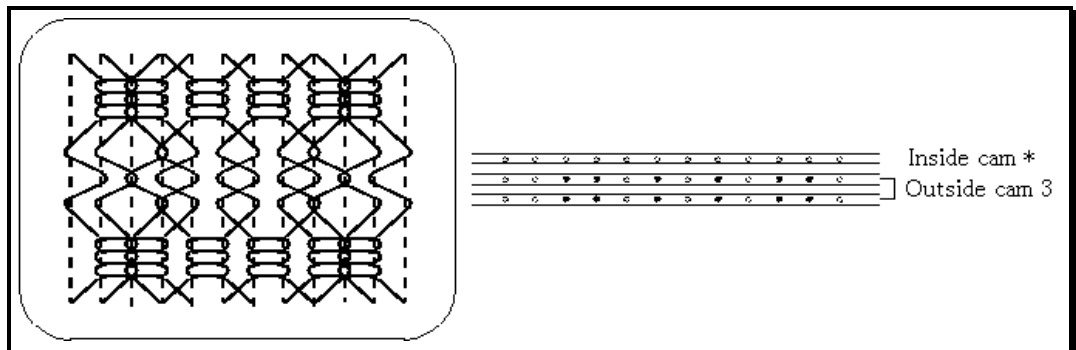

No.4

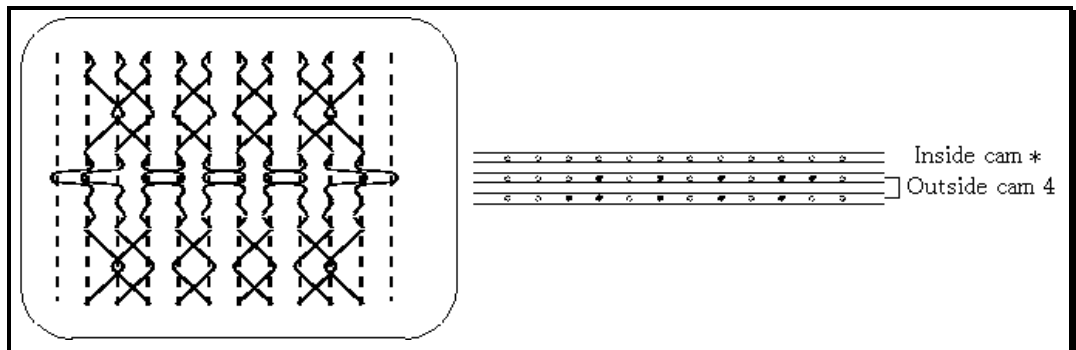

No.5

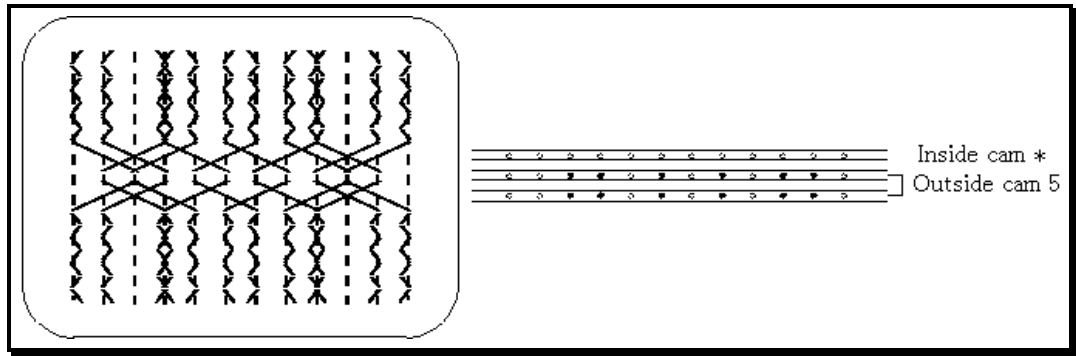

No.6

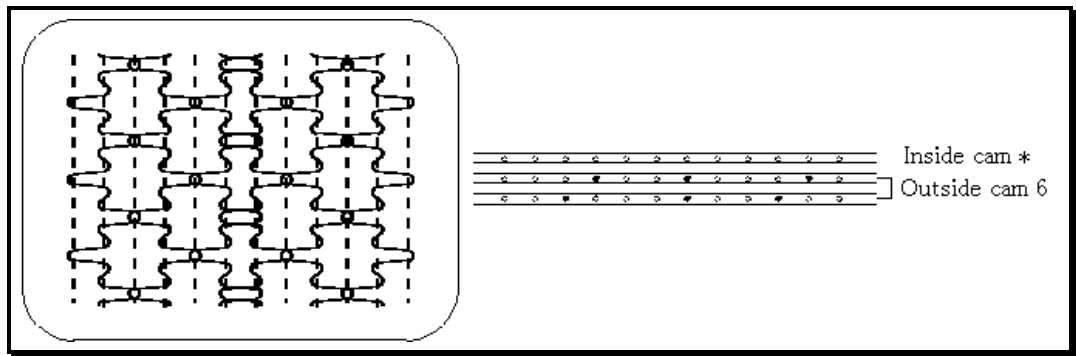

No.7

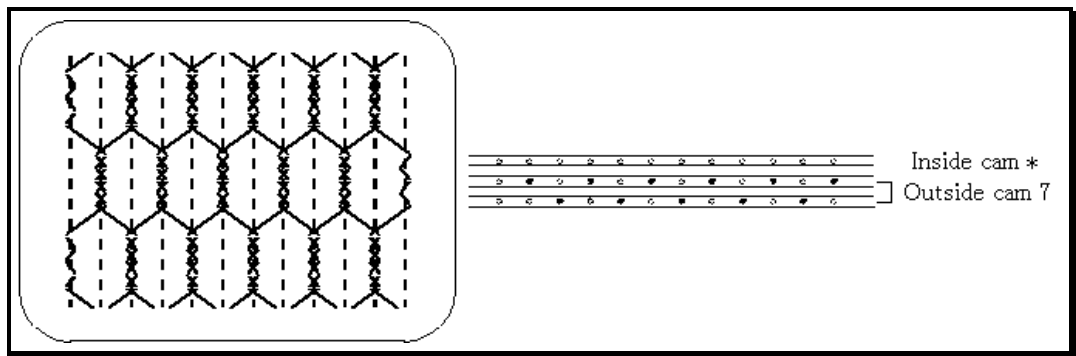

No.8

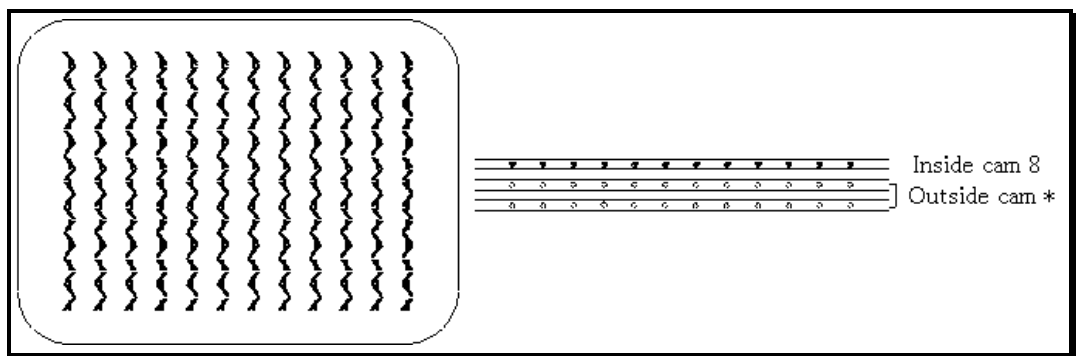

No.9

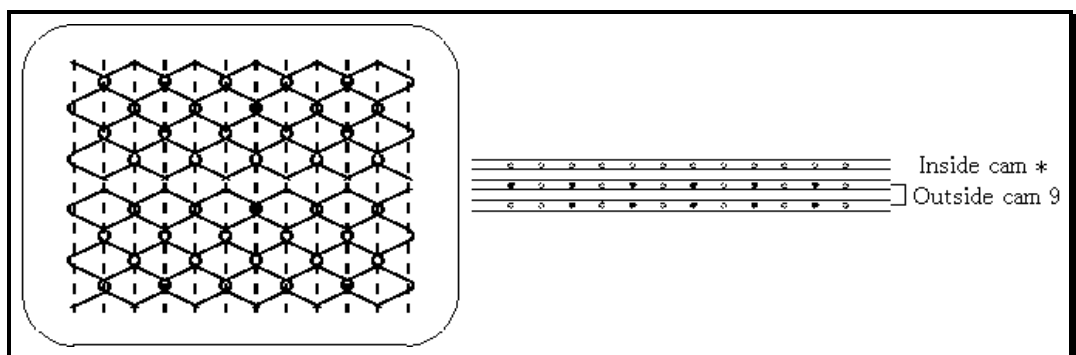

13-3 Replacing the cams

To replace outside cam B, remove nut A (note that this nut has a left-hand thread).

To replace inside cam H, loosen screws C and D, and remove the collar. Remove screw F from lever S.

Then move lever S down in the direction of the arrow.

< Note >

Before installing new cams, be sure to grease the cam grooves. Never loosen screws I and J. Otherwise the timing of spreaders is changed.

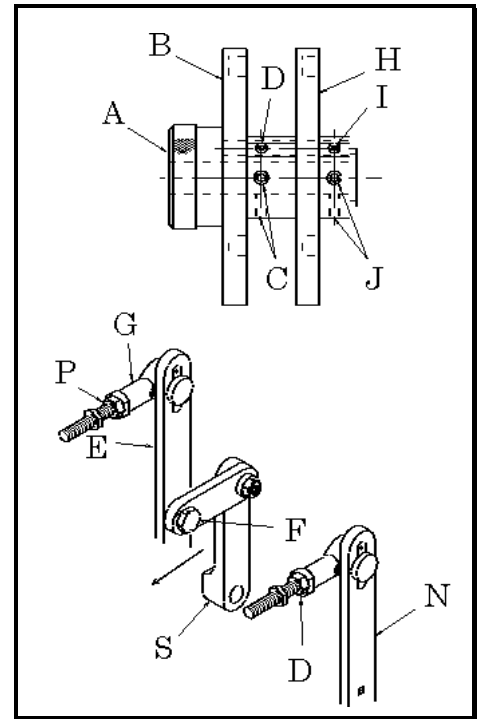

13-4 Timing of spreaders

To adjust this timing, set cam No.8 on the inside and No.1 on the outside. Then follow the procedures below. Spreader K moves left to right with the inside cam. Each of spreaders L and M moves in the opposite direction with the outside cam.

1. When the needle starts to move from the top to the bottom of its stroke, adjust the cams so that spreaders K, L and M stop moving. Adjustment is made by loosening screws C and J (see "Replacing the cams").
2. Position of spreader K
With spreader K at the extreme left end of its travel, the third spreader's eye on spreader K should be aligned with the center of the left end needle. Adjustment is made by loosening nut D for lever N (see "Replacing the cams").
3. Position of spreaders L and M
With spreader L at the extreme left end of its travel, the fourth spreader's eye on spreader L should be aligned with the center of the left end needle. Adjustment is made by loosening nut P for lever E (see "Changing the cams").
With spreader L at the extreme right end of its travel, make sure the fifth spreader's eye on spreader M is aligned with the center of the left end needle.

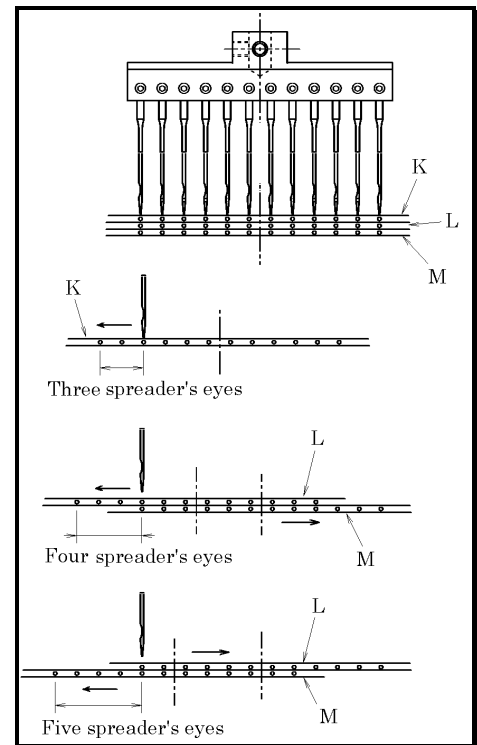

13-5 Adjusting the spreaders

The clearance between spreader K , L and M and needles should be 1~1.2mm.

Spreader up-and-down adjustment is made with screws Q.

Spreader tilt adjustment is made with screws R.

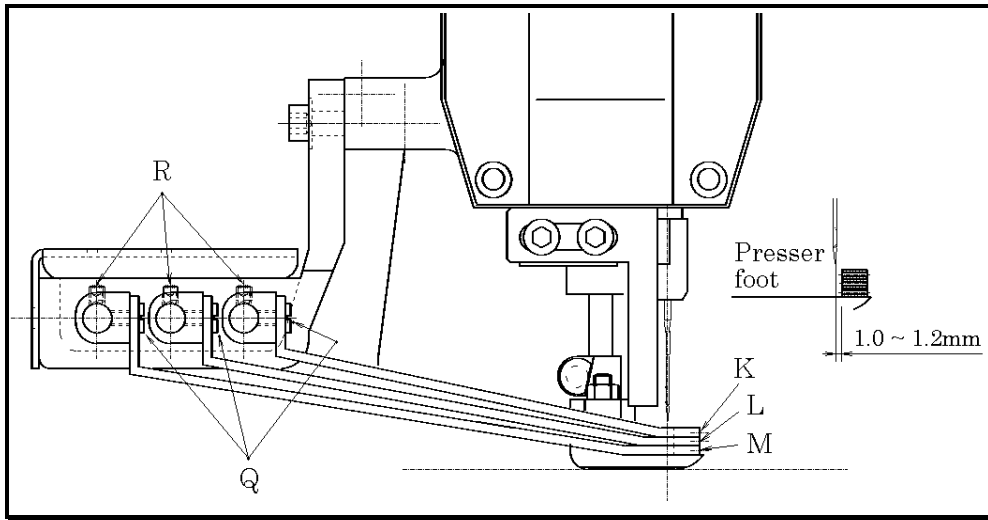

【14】 PTV MECHANISM

14-1 Disassembling and reassembling the binder

To disassemble the binder

Remove screw A. Remove the binder by pulling it toward you while referring to arrows B and C.

< Note >

When removing the binder, be careful not to damage the ends of the fabric guides.

To reassemble the binder

Fit the ends of upper fabric guides (F) onto lower fabric guides (G). Move the binder down in the direction of arrow H. Check that end D of the screw touches the bracket. Then tighten screw A.

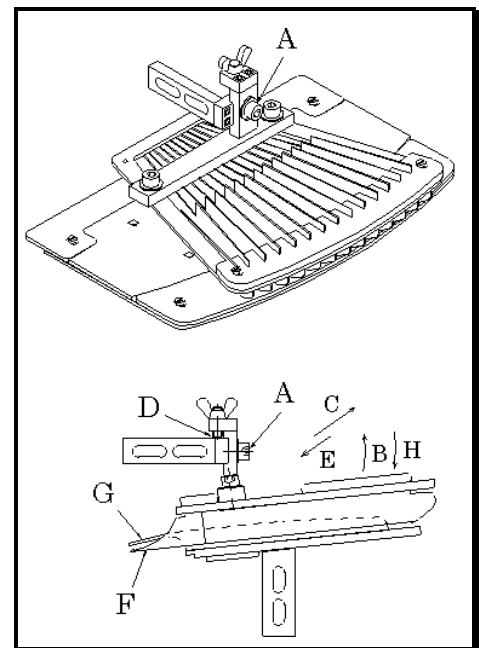

14-2 Adjusting the binder up and down

Adjust the binder up and down according to the fabric to be used. Adjustment is made by loosening screw A and wing screw I and turning screw D as required.

After this adjustment is made, tighten screw A and wing screw I.

< Note >

Adjust the position of J and K according to the finished pin tuck.

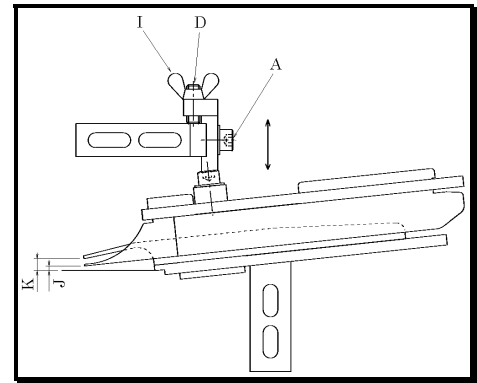

14-3 Position of the upper and lower fingers of the binder

Position upper and lower fingers so that distance A is halved by each vertical center line of the needles.

The line formed by the points of the upper and lower fingers should be parallel with each horizontal center line of the needles.

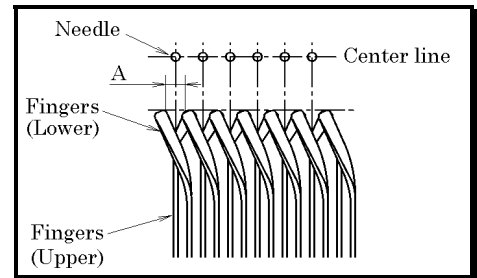

【15】CLEANING THE MACHINE

At the end of each day, remove the presser foot and the needle plate and then clean the slots of the needle plate and the area around the feed dogs.

