

**JUKI**

**1-Needle, Post-Bed, Top and Bottom Wheel-Feed  
Lockstitch Machine  
With a Reverse Feed Mechanism**

**PLW-1246**

**ENGINEER'S MANUAL**

---

1

D

D

1

Model PLW-1246 (1-Needle, Post-Bed, Top and Bottom Wheel-Feed  
Lockstitch Machine with a Reverse Feed Sewing Mechanism)

## CONTENTS

1. Specifications .....	1
2. Standard adjustments .....	3
1. Needle bar .....	3
(1) Needle entry point .....	3
(2) Height of the needle bar .....	5
2. Timing between the needle and the shuttle .....	7
(1) Rising amount of the needle .....	7
(2) Positioning of the needle and blade point of the shuttle .....	7
(3) Effective amount of the protruding needle guard .....	7
(4) Clearance between the needle and the blade point of the shuttle .....	7
(5) Replacing the shuttle .....	9
3. Shuttle guide .....	11
4. Clearance between the bobbin case stopper of the throat plate and the shuttle .....	13
5. Adjusting the timing of the cloth feed movement and the seam .....	15
(1) Timing of the cloth feed movement .....	15
(2) Seam adjustment .....	17
6. Height of the bottom roller .....	19
7. Top roller .....	21
(1) Height of the top roller (lift amount of the presser foot by the hand lifter) .....	21
(2) Clearance between the roller and the needle .....	23
8. Adjusting the top feed amount .....	25
9. Lower clutches .....	27
10. Installing the belt .....	29
11. Safety mechanism .....	31
(1) Releasing the safety mechanism .....	31
(2) Adjusting the pressure of the safety mechanism .....	31
12. Knee lifter .....	33
3. Standard adjustment according to the types of thread and material .....	35
1. Sewing conditions when using andaria thread .....	35
4. Troubleshooting during a sewing operation .....	39
1. Thread breakage .....	39
2. Stitch skipping .....	39
3. Loose stitches (isolated idling loops) .....	40
4. Irregular stitches .....	41

## 1. Specifications

No.	Item	Specification
1	Model	PLW-1246
2	Name	1-needle, post-bed, top and bottom wheel-feed lockstitch machine with a reverse feed sewing mechanism)
3	Application	Sewing shoe toe caps
4	Sewing speed	Normal 2,000 s.p.m.
5	Needle	SCHMETZ 134LR
6	Thread	#8 to #40 Standard #20
7	Gauge size	1.2, 1.6, 2.1
8	Stitch length	0.8 to 4.5 mm (0.031" to 0.177") (normal feed and reverse feed)
9	Lift of the presser foot	By the hand lifter : 7 mm (0.276") By the knee lifter : 9 mm (0.354")
10	Auto lifter	Option
11	Stitch adjustment mechanism	Push-button system
12	Reverse feed sewing	By a lever
13	Thread take-up	Link-type thread take-up
14	Needle bar stroke	38 mm (1.496")
15	Shuttle	Standard vertical shuttle with a bobbin case
16	Opener	Interlocked with the shuttle shaft eccentric cam (1:1 method)
17	Feed mechanism	Top and bottom roller intermittent feed
18	Shuttle drive mechanism	By bevel gear
19	Needle feed mechanism	_____
20	Drive of the main shaft and shuttle drive shaft	Timing belt system
21	Lubrication	Semi-automatic
22	Circulation system	By felt
23	Thread trimming mechanism	_____
24	Disc floating mechanism	_____
25	Wiper mechanism	_____
26	Motor	Single-phase, 3-phase, 250W 4P clutch motor
27	Control box	_____
28	Lubrication oil	New Defrix Oil No. 1
29	Bed size	178 mm (L) x 517 mm (W) (7.008" x 20.354")
30	Weight of the machine head	53 kg

o Gauge size and symbols

Gauge size	1.2 mm (0.047")	1.6 mm (0.063")	2.1 mm (0.083")
Gauge symbol	A	B (standard)	C

## 1. Needle bar

## (1) Needle entry point

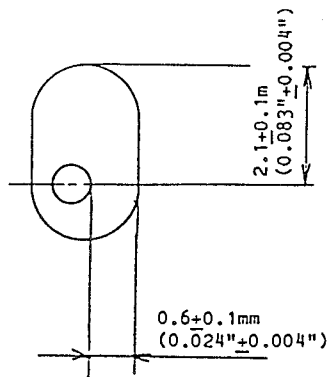

Operator's side

Fig. 1

- o The distance between the needle entry point and the top end of the needle hole in the throat plate is  $2.1 \pm 0.1$  mm ( $0.083 \pm 0.004$ " (unadjustable)).
- o The needle should enter the needle hole in the throat plate with a  $0.6 \pm 0.1$  mm ( $0.024 \pm 0.004$ " ) clearance between the needle and the right edge of the hole.

## Conditions

- o The needle bar is at its lowest dead point.

### HOW TO ADJUST

- (1) Needle entry point (lateral direction)
  - 1) Turn the handwheel so that the needle bar is carried to its lowest dead point.
  - 2) Loosen four feed base setscrews ①.
  - 3) Slide the feed base along the groove in the bed to obtain the specified distance in the lateral direction.
  - 4) Tighten four setscrews ①.

#### (Caution)

The feed base might move slightly out of position when the setscrews are tightened. Be sure to check that the feed base has been correctly set in the specified position after tightening the setscrews.

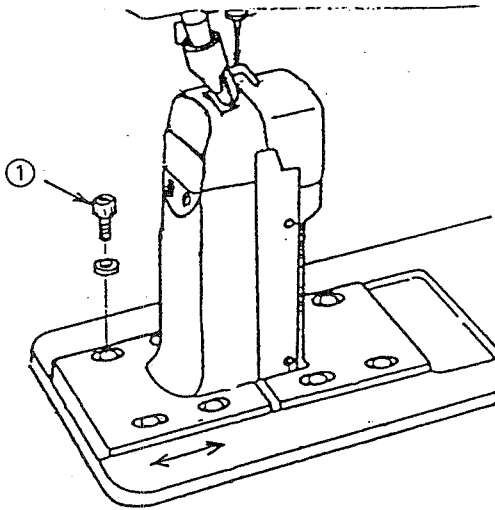
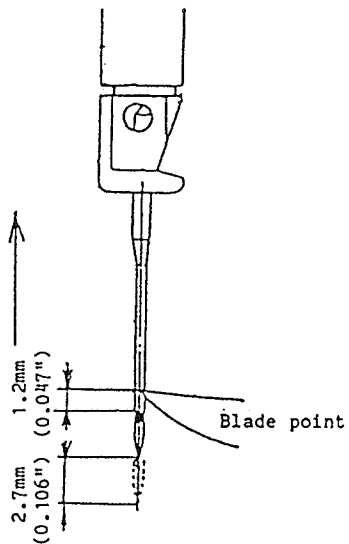

Fig. 2

### RESULTS OF IMPROPER ADJUSTMENT

- o Stitch skipping and thread breakage may result.
- o Loose stitches may result.

## (2) Height of the needle bar



- o The needle bar rises 2.7 mm (0.106") from its lowest dead point.
- o The distance between the needle and the blade point of the shuttle is 1.2 mm (0.047") (standard adjustment).

## Conditions

- o The needle bar rises from its lowest dead point.

Fig. 3



## HOW TO ADJUST

### (2) Height of the needle bar

- 1) Loosen connecting stud clamping screw ① of the needle bar.
- 2) Move the needle bar to obtain the specified distance. Then tighten connecting stud clamping screw ①.

#### (Note)

The distance specified is the standard factory adjustment at the time of delivery.

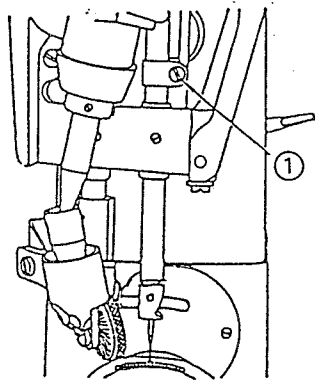

Fig. 4

## RESULTS OF IMPROPER ADJUSTMENT

2. Timing between the needle and the shuttle

(1) Rising amount of the needle

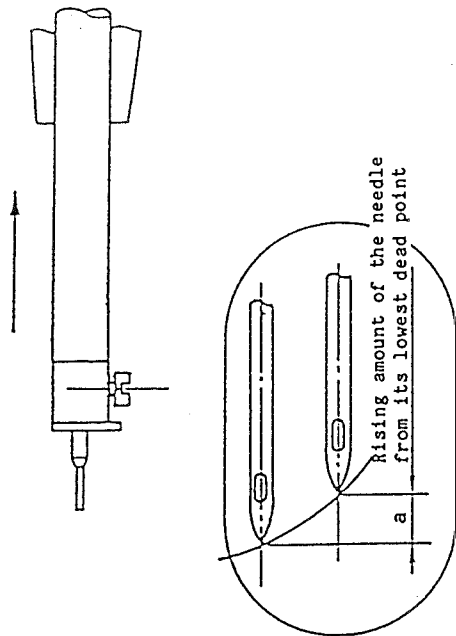

Fig. 5

(2) Positioning of the needle and blade point of the shuttle

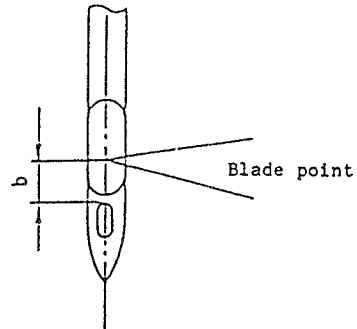

Fig. 6

Distance a: Rising amount of the needle	Point b: Blade point position
2.7+0.2mm (0.106"±0.008")	1.2+0.2mm (0.047"±0.008")

(3) Effective amount of the protruding needle guard

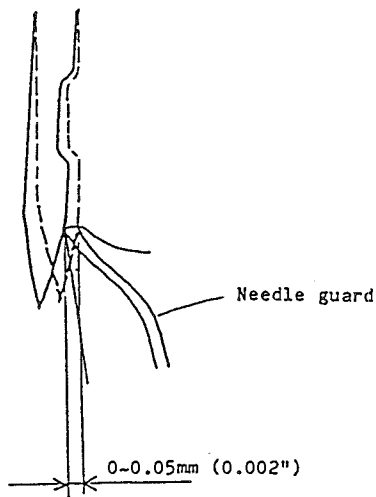

Fig. 7

(4) Clearance between the needle and the blade point of the shuttle

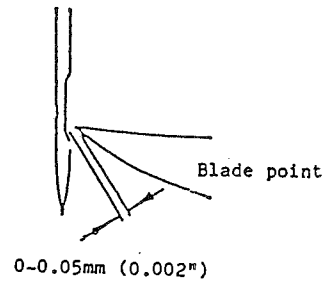

Fig. 8

Conditions

- o The needle bar goes up from the lowest dead point of its stroke.

HOW TO ADJUST	RESULTS OF IMPROPER ADJUSTMENT
<p>Adjusting the height of the needle bar</p> <ol style="list-style-type: none"> <li>1. Set the feed adjustment dial to 0.8.</li> <li>2. Loosen three setscrews ① in the bevel gear of the shuttle driving shaft.</li> <li>3. Loosen four setscrews ② in the saddle of the shuttle driving shaft.</li> <li>4. Temporarily tighten the clamping screw of the needle bar connecting stud.</li> <li>5. Move the needle bar up or down so that the blade point of the shuttle is aligned with the top end of the needle eyelet when the needle bar has risen 3.9 mm (2.7mm+1.2mm) (0.154" (0.106"+0.047")) from the lowest dead point of its stroke. Then tighten the clamping screw in the needle bar connecting stud.</li> </ol>	<ul style="list-style-type: none"> <li>o An uneven material feed, stitch skipping, or thread breakage may result.</li> <li>o An uneven material feed is eliminated by delaying the shuttle timing.</li> <li>o An isolated idling loop occurs when the shuttle timing is too early or too late.</li> </ul>
<p>Adjusting the saddle of the shuttle driving shaft</p> <ol style="list-style-type: none"> <li>6. Slide the saddle of the shuttle driving shaft along the groove in the bed to obtain the specified clearance between the needle and the blade point of the shuttle. Then tighten setscrews ②.</li> </ol> <p>(Caution) After tightening setscrews, be sure to check that the specified clearance has been obtained.</p>	
<p>Adjusting the effective amount of the protruding needle guard</p> <ol style="list-style-type: none"> <li>7. Adjust so that the needle comes in slight contact (0 to 0.05mm (0.002")) with the needle guard when the needle reaches the blade point of the shuttle. <ul style="list-style-type: none"> <li>o Bend the needle guard inward by pressing a screwdriver against the outside of the needle guard.</li> <li>o Bend the needle guard outward by pressing a screwdriver against the inside of the needle guard.</li> </ul> </li> </ol>	<p>If there is excessive needle contact with the needle guard:</p> <p style="padding-left: 40px;">The needle may wear out sooner than normal. Needle may break.</p> <p>If there is insufficient needle contact with the needle guard:</p> <p style="padding-left: 40px;">Stitch skipping or thread breakage may result.</p>
<p>Adjusting the shuttle driving shaft</p> <ol style="list-style-type: none"> <li>8. Adjust so that the center of the needle is almost aligned with the blade point of the shuttle when the needle has risen 2.7 mm (0.106") from the lowest dead point of its stroke. Then install bevel gear ① in the shuttle driving shaft.</li> </ol> <p>(When the needle bar is at its lowest dead point, engraved marker dot No. 1 on the handwheel will be aligned with the engraved marker dot on the machine arm. Now, turn the handwheel toward you until engraved marker dot No. 3 on the handwheel is aligned with the engraved marker dot on the machine arm. The needle bar will have risen approximately 2.7 mm (0.106") from the lowest dead point of its stroke.)</p>	

(5) Replacing the shuttle

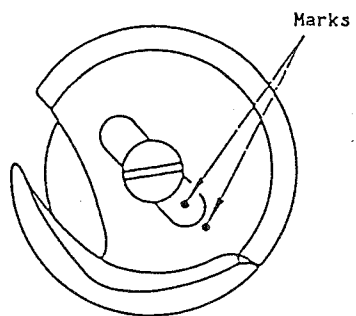

Condition

- o Be sure to align the mark on the shuttle with the mark on the shuttle driving shaft.

Fig. 12

HOW TO ADJUST

RESULTS OF IMPROPER ADJUSTMENT

(Caution)

After the specified distance has been obtained and setscrews ① have been tightened, be sure to check that the amount of backlash has not changed.

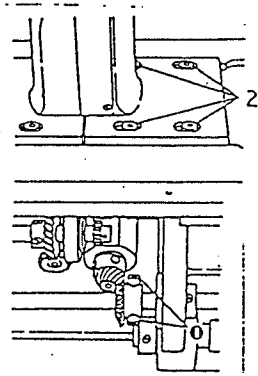

Fig. 9

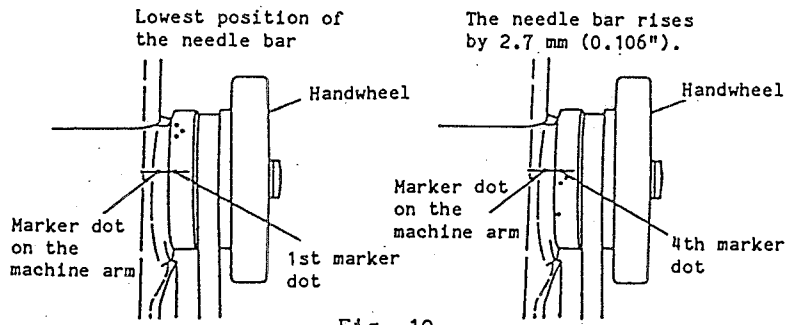

Fig. 10

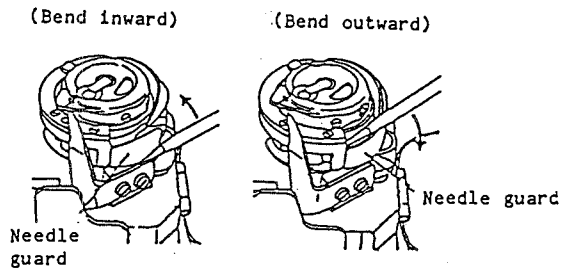

Fig. 11

## 3. Shuttle guide

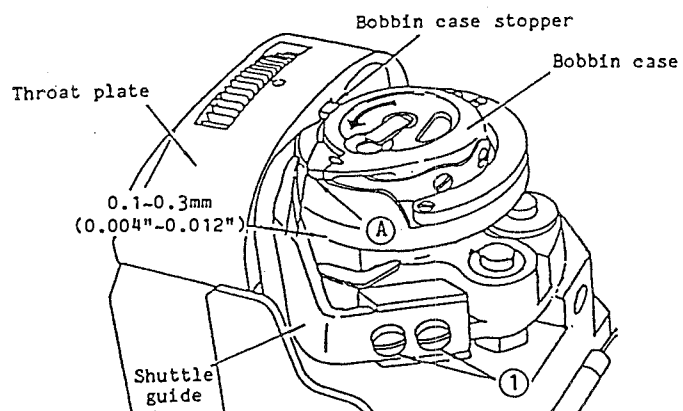

Fig. 13

## Conditions

- o The shuttle guide must be at its backward end.
- o Press the bobbin case stopper toward the groove in the throat plate.

HOW TO ADJUST	RESULTS OF IMPROPER ADJUSTMENT
<ol style="list-style-type: none"><li>1) Turn the handwheel in the normal direction so that the shuttle guide reaches its backward end.</li><li>2) Turn the bobbin case as shown in the arrow so that the bobbin case stopper fits in the groove in the throat plate.</li><li>3) Loosen setscrews ① and adjust so that a 0.1 to 0.3 mm (0.004" to 0.012") clearance is obtained between the shuttle guide and protruding section ① of the bobbin case. Then tighten setscrews ①.</li></ol>	

## 4. Clearance between the bobbin case stopper of the throat plate and the shuttle

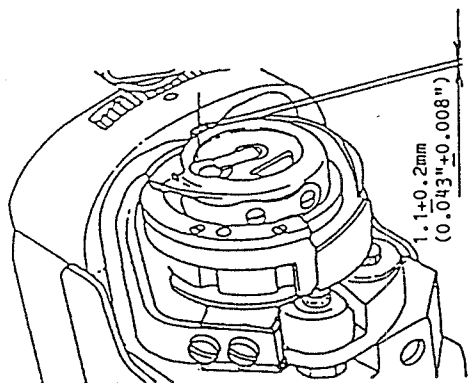

Fig. 14

- o Clearance between the top end of the groove in the bobbin case stopper of the throat plate and the top face of the bobbin case stopper of the shuttle:  $1.1 \pm 0.2$  mm ( $0.043 \pm 0.008$ " )



## HOW TO ADJUST

- 1) Loosen the three setscrews in the shuttle gear of the shuttle driving shaft.
- 2) Remove the shuttle guide.
- 3) Remove four setscrews (1) in the saddle of the shuttle driving shaft, and remove the saddle of the shuttle driving shaft.
- 4) Loosen four setscrews (2) in the thrust collar of the shuttle driving shaft.
- 5) Loosen setscrew (3) in the bevel gear of the shuttle driving shaft, remove the bevel gear, and pull out both the shuttle and the shuttle driving shaft.
- 6) Loosen setscrew (4) in the upper bushing of the shuttle driving shaft, and adjust the clearance between the bobbin case stopper of the throat plate and the shuttle by changing the height of the upper bushing of the shuttle driving shaft.  
The height of the upper bushing of the shuttle driving shaft has been factory-adjusted to  $8.1+0.1$  mm ( $0.319''+0.004''$ ) as standard.  
 $-0.2$   $-0.008''$
- 7) After making the adjustment, be sure to check that the adjustments described in "2. Timing between the needle and the shuttle" on page 7 and "3. Shuttle guide" on page 11.

## RESULTS OF IMPROPER ADJUSTMENT

If the clearance is too great:

- o The shuttle might come off from the throat plate.

If the clearance is too small:

- o Loose stitches (isolated idling loops) may result.

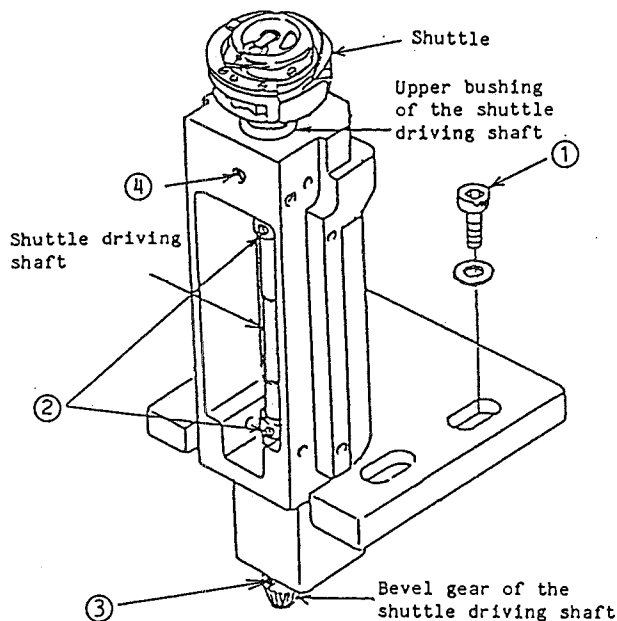

Fig. 15

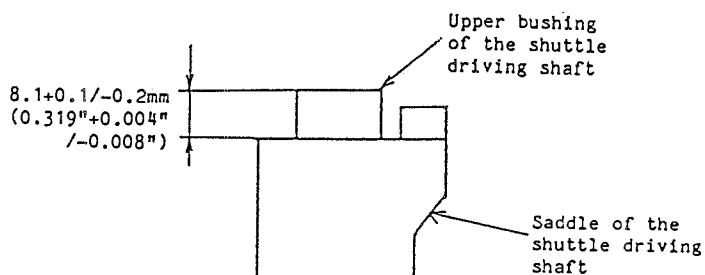

Fig. 16

## 5. Adjusting the timing of the cloth feed movement and the seam

## (1) Timing of the cloth feed movement

The roller should stop feeding when the needle has gone 6 mm (0.236") below the surface of the throat plate.

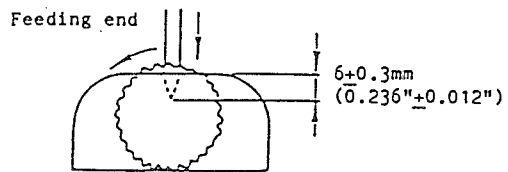

Fig. 17

HOW TO ADJUST	RESULTS OF IMPROPER ADJUSTMENT
---------------	--------------------------------

- (1) Feed timing
- 1) Set the feed amount to the maximum value. (Feed amount: 4.5 mm (0.177"))
  - 2) Loosen the setscrews (two hexagonal socket setscrews) in the feed adjuster unit and temporarily tighten them.
  - 3) Turn the handwheel toward you until the tip of the needle moves 9 mm (0.354") from the needle hole in the throat plate. (The top end of the needle eyelet now moves 1 mm (0.039") down from the top surface of the throat plate. Use this as a reference point.)
  - 4) Hold the handwheel in the above position, turn the feed adjustment dial toward you until the feeding arm D reaches the side end (in the direction of the arrow). Then tighten the setscrews in the feed adjuster unit.

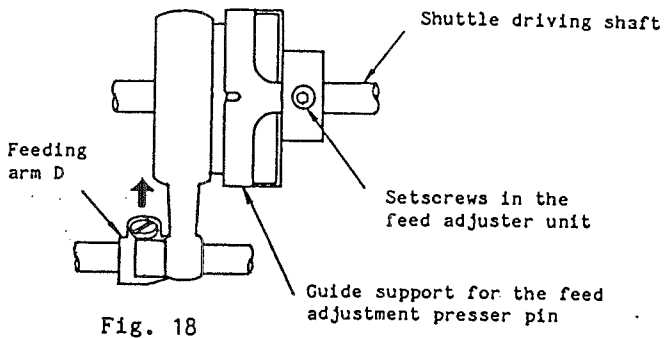
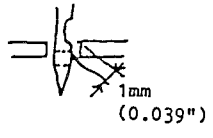

Fig. 18

(Caution)  
 The setscrews in the feed adjuster unit should be aligned with the tapped hole of the guide support for the feed adjustment presser pin when the feed amount is set to the maximum (4.5 mm (0.177")).

- If the feed timing is too early:
- o Loose stitches may result.
- If the feed timing is too late:
- o Loose stitches may result.
  - o If the timing of the cloth feed movement is excessively delayed, the needle might break.

(2) Seam adjustment

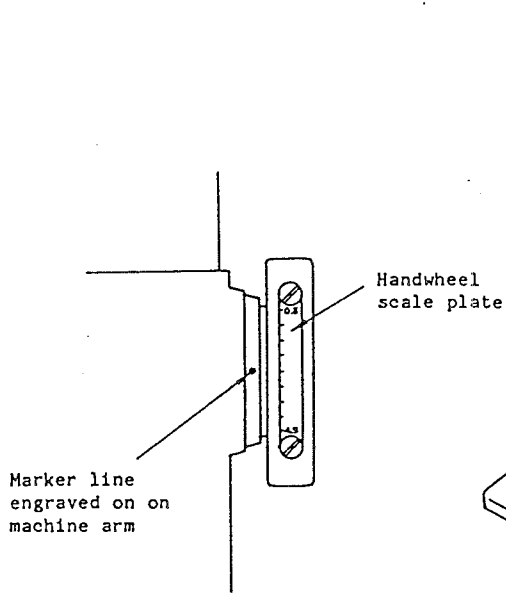

Fig. 19

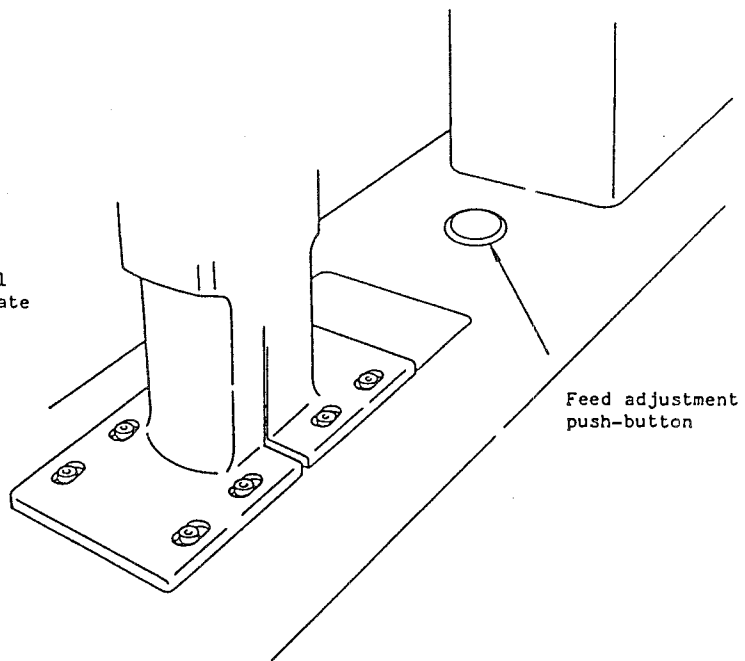

Fig. 20

## HOW TO ADJUST

## RESULTS OF IMPROPER ADJUSTMENT

### (2) Adjusting the seam

- 1) Press the feed adjustment push-button until the top end of the push-button is aligned with the groove in the pin guide support for the feed adjustment presser pin. The value on the handwheel scale plate indicated by the marker dot on the machine arm shows the stitch length.
- 2) The stitch length can be changed by further turning the handwheel with the push-button held down, so that the scale value indicated by the marker dot changes.

### (Caution)

If the timing of the cloth feed movement is changed, the scale value indicated by the marker dot will also be changed, so after adjusting the timing of the cloth feed movement, be sure to loosen the scale plate setscrew and re-adjust the scale plate to obtain the stitch length desired.

When the feed adjustment push-in pin is set to the seventh tooth in the feed adjustment ratchet, the feed amount shown on the scale plate of the handwheel is 3.

Feed adjustment  
push-in pin

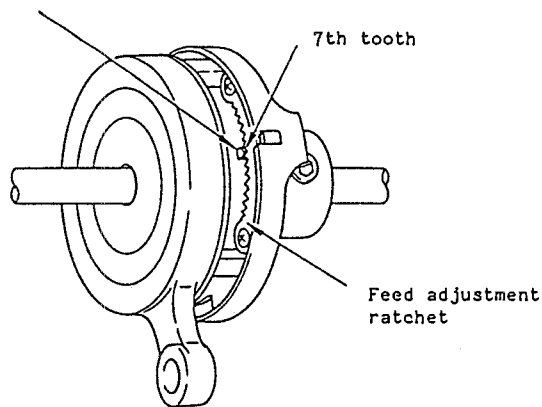
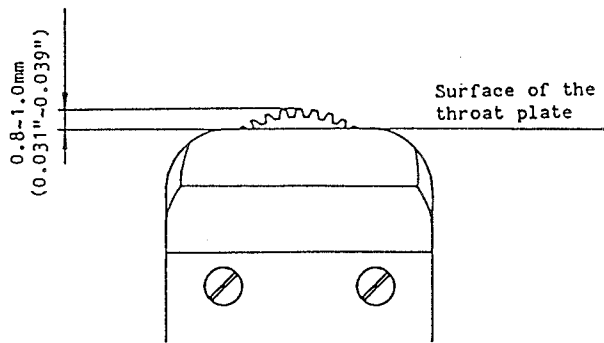

Fig. 21

## 6. Height of the bottom roller



## Condition

- o The top end of the feed dog protrudes 0.8 to 1.0 mm (0.031" to 0.039") from the surface of the throat plate.

Fig. 22

HOW TO ADJUST

1. Loosen setscrews ① and remove cover ②.
2. Loosen setscrews ③ and ④, and adjust the height of bottom roller ⑥ by turning height adjustment screw ⑤.
3. First tighten setscrew ④. Then tighten setscrews ③.
4. To sew ordinary leather, set the height of the bottom roller to 0.8 to 1.0 mm (0.031" to 0.039") (standard adjustment).  
When the indented section of the tooth on the bottom roller is aligned with the top surface of throat plate ⑦, the height of the bottom roller will be approximately 1.0 mm (0.039").

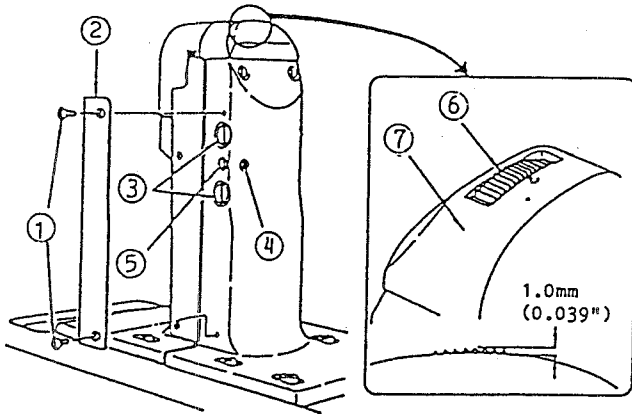

Fig. 23

RESULTS OF IMPROPER ADJUSTMENT

- If the bottom roller is positioned too high:  
An uneven material feed, stitch skipping, or thread breakage may result.
- If the bottom roller is positioned too low:  
It will not be possible to feed the material smoothly.

## 7. Top roller

- (1) Height of the top roller (lift amount of the presser foot by the hand lifter)

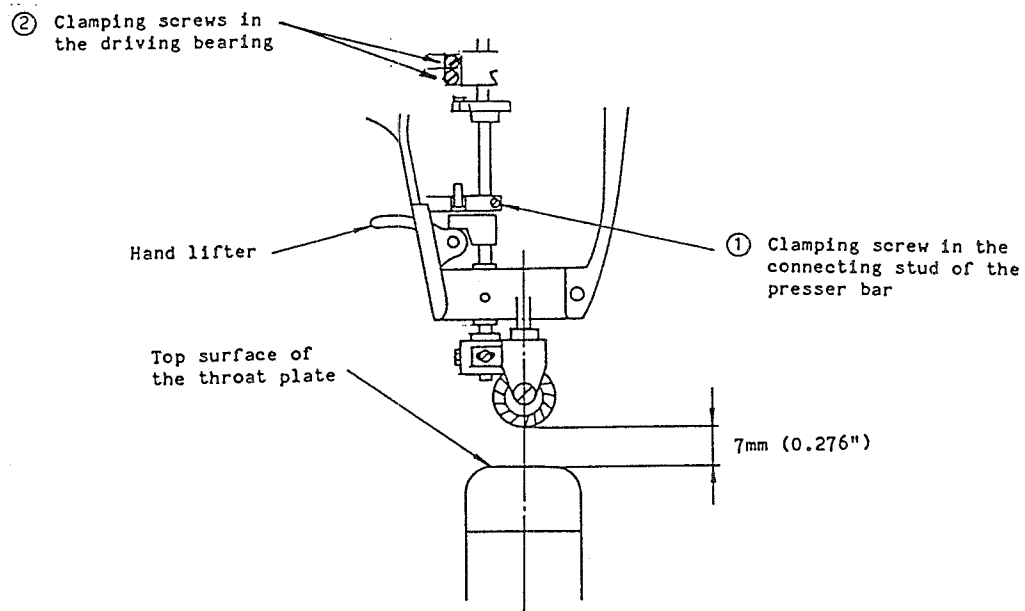
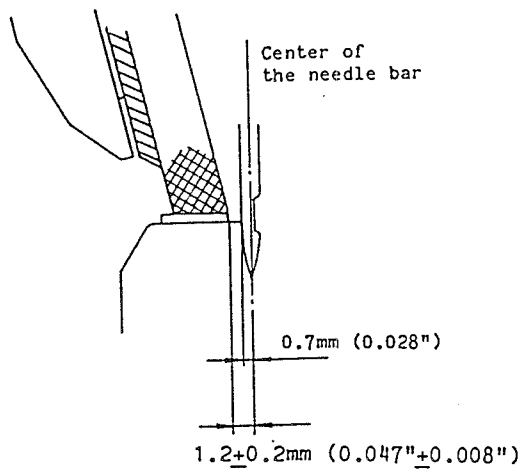

Fig. 24



HOW TO ADJUST	RESULTS OF IMPROPER ADJUSTMENT
<p>(1) Height of the top roller Loosen connecting stud clamping screw ① and clamping screws ② in the top roller driving bearing, and adjust the height of the top roller by moving the presser bar.</p> <p>(Note) After making the adjustment, check that the top roller is parallel with the bottom roller.</p>	

(2) Clearance between the roller and the needle



Condition

o Needle : 134LR #90

Fig. 25

## HOW TO ADJUST

- (2) Clearance between the top roller and the needle
- 1) The center of the roller shaft should be aligned with the center of the needle bar shaft.  
Loosen setscrew ③ in the roller holder, and adjust so that the center of the roller shaft is aligned with the center of the needle bar shaft. Then tighten setscrew ③.
  - 2) Loosen setscrew ④ in the roller holder bracket, and adjust so that a 0.7 mm (0.028") clearance is obtained between the roller and the needle.  
Then tighten the setscrew.

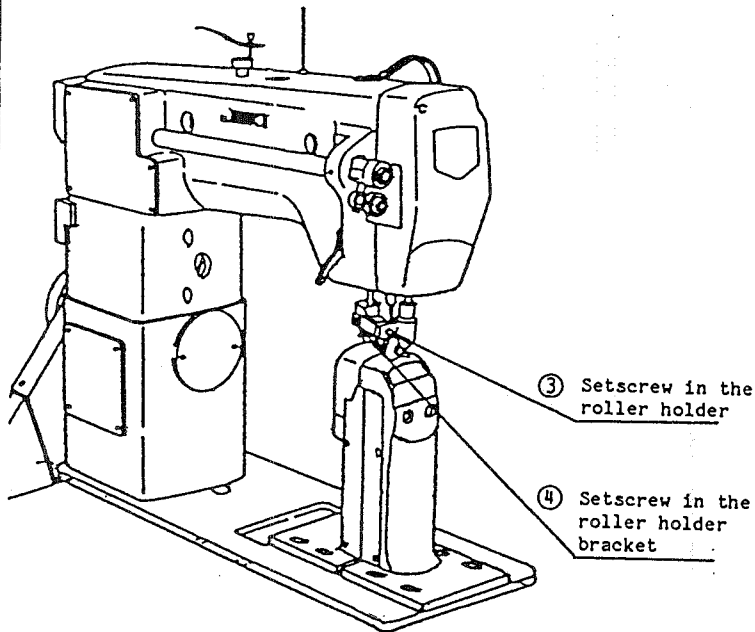

Fig. 26

(Note)

When the presser foot is raised, be sure to check that there is an adequate clearance between the needle trunk and the roller with the needle bar having been carried to the lowest dead point of its stroke.

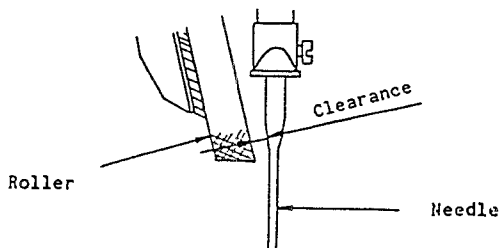

Fig. 27

## RESULTS OF IMPROPER ADJUSTMENT

- o The tip of the roller may come in contact with the needle.
- o If the clearance between the roller and the needle is too great, stitch skipping or thread breakage may result.

## 8. Adjusting the top feed amount

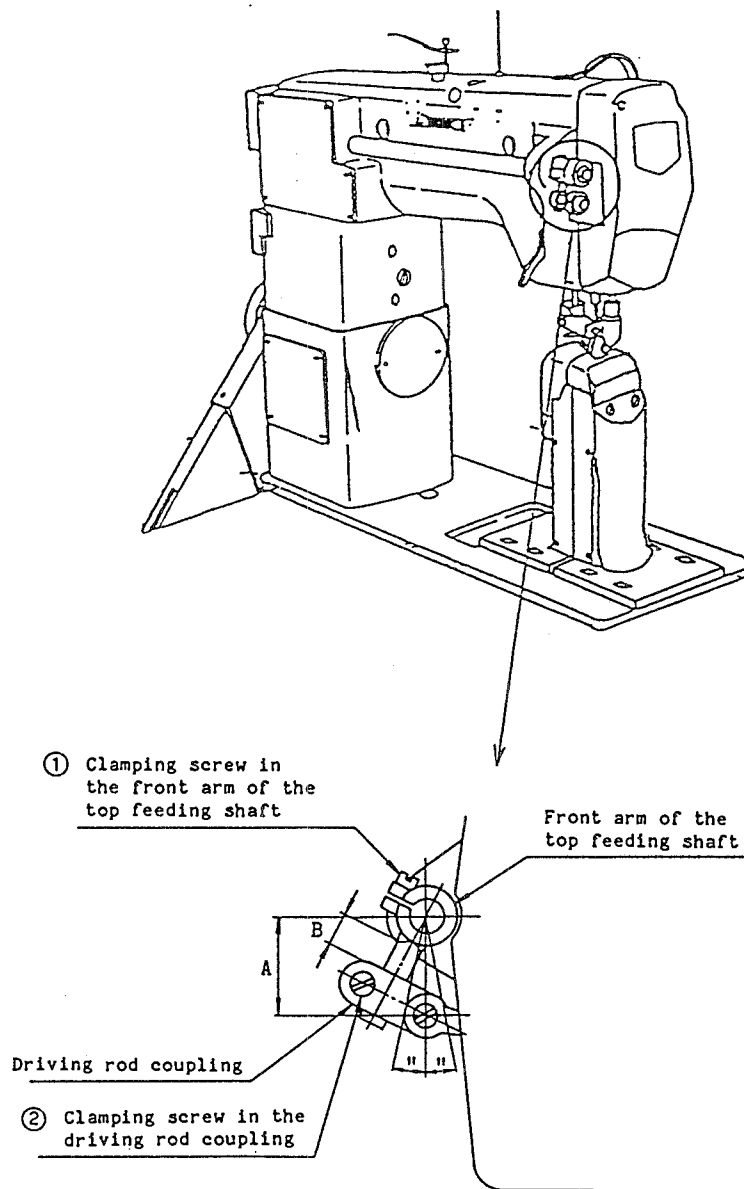

Fig. 28

	Dimension A	Dimension B
∅35 roller	20.5mm (0.807")	1.5+0.2mm (0.059"±0.008")
∅25.4 roller	20.5mm (0.807")	1.5+0.2mm (0.059"±0.008")

## Condition

o Feed amount : Max. 4.5 mm (0.177")

o The above components are factory-assembled so that the feed amount of the bottom roller is the same as that of the top roller.

HOW TO ADJUST

- 1) Angle of swing of the front arm of the top feed shaft  
Adjust so that the front arm of the top feed shaft swings back and forth at equal angles, as observed from the point just under the front arm of the top feed shaft. Then tighten clamping screw ① in the front arm of the top feed shaft.
- 2) Positioning the driving rod coupling  
Adjust the position of the driving rod coupling so that a  $1.5 \pm 0.2$  mm ( $0.059 \pm 0.008$ " ) distance is obtained for a distance B. Then tighten clamping screw ② in the driving rod coupling.

RESULTS OF IMPROPER ADJUSTMENT

If the top and bottom feed amounts do not have the same value, an uneven material feed may result.

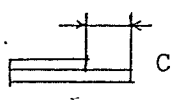
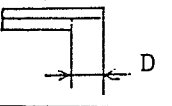
Conditions for an uneven material feed	Feed amount
	Top feed amount > Bottom feed amount
	Top feed amount < Bottom feed amount

Test data)

Relationship between the feed amount of the top roller and distance B  
(with the feed scale set to 3 mm (0.118"))

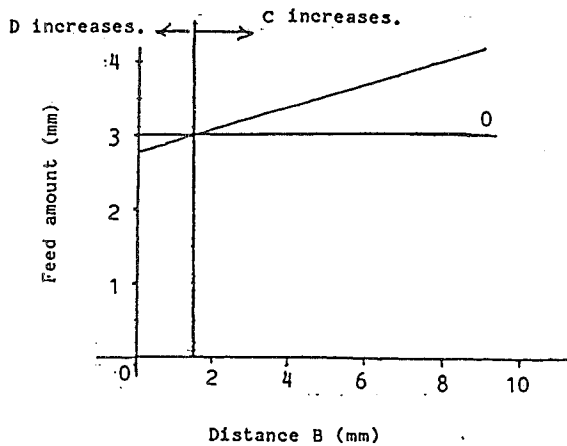

## 9. Lower clutches

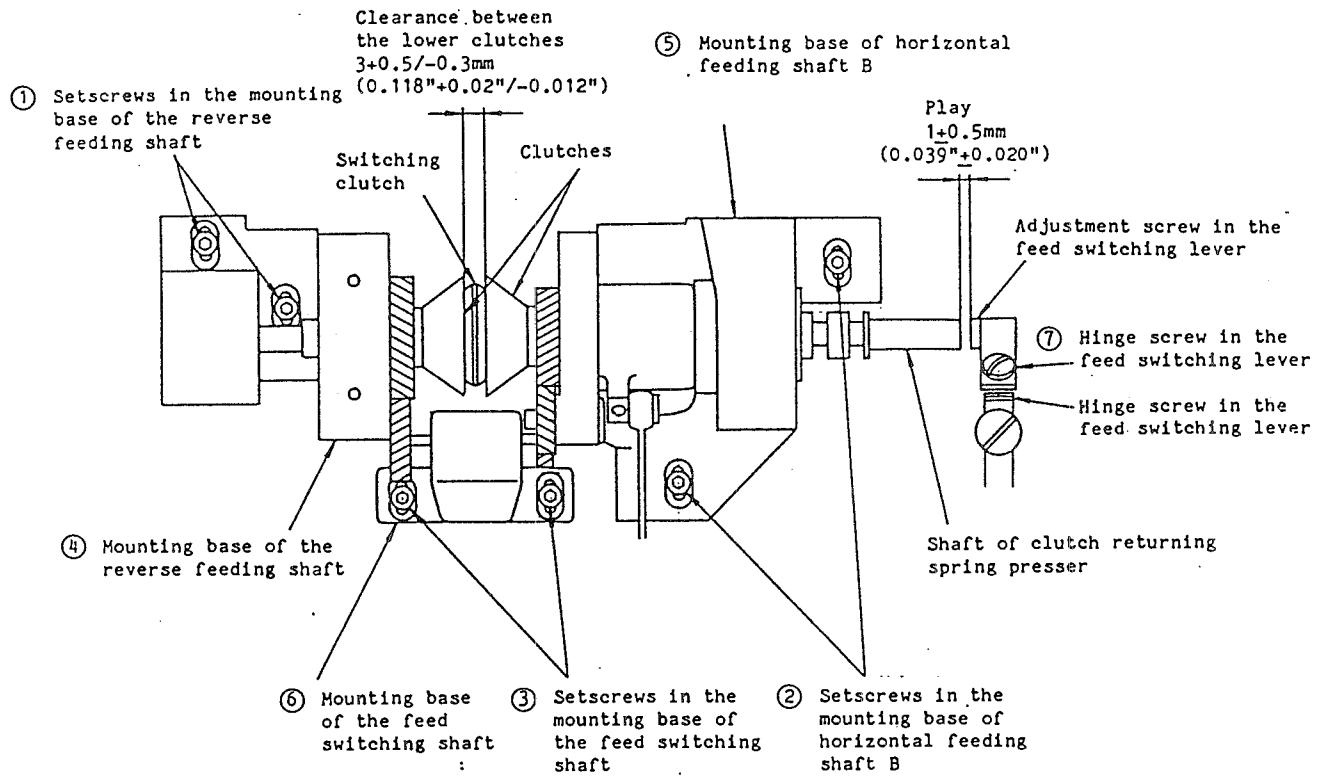

Fig. 29

HOW TO ADJUST	RESULTS OF IMPROPER ADJUSTMENT
<p>(1) Clearance between the lower clutches</p> <ol style="list-style-type: none"> <li>1) Loosen setscrews ①, ② and ③.</li> <li>2) Lightly tighten setscrews ①.</li> <li>3) Move mounting base ⑤, and adjust as standard the clearance between the clutches. Then lightly tighten setscrews ②.</li> <li>4) Move mounting base ⑥ so that the gear of mounting base ⑥ engages with the gears of mounting bases ④ and ⑤. Then lightly tighten setscrews ③.</li> <li>5) Turning the handwheel, press the reverse feeding lever several times in order to check that the bottom roller can turn in both the normal and reverse directions.</li> <li>6) Firmly tighten setscrews ①, ② and ③.</li> </ol> <p>(Caution) If the center of the shaft of mounting base ④ is not aligned with that of mounting base ⑤, the feed movement may not be normal so, after assembly, be sure to carry out step 5) described above to check that the rotation of the bottom roller is normal.</p>	<p>If the clearance is too small:</p> <ul style="list-style-type: none"> <li>o The switching clutch may fail to be released and the reverse feed mechanism may not function.</li> </ul> <p>If the clearance is too great:</p> <ul style="list-style-type: none"> <li>o The switching clutch may fail to touch the clutch in the mounting base of the reverse feeding shaft and the reverse feed mechanism may not function.</li> </ul>
<p>(2) Play between shaft of the clutch returning spring presser and the adjustment screw in the feed switching lever</p> <ol style="list-style-type: none"> <li>1) Loosen hinge screw ⑦.</li> <li>2) Turn the adjustment screw in the feed switching lever to obtain the play specified as standard adjustment.</li> <li>3) Tighten hinge screw ⑦.</li> </ol>	<p>If the play is inadequate:</p> <ul style="list-style-type: none"> <li>o The normal feed mechanism may fail to function.</li> </ul> <p>If the play is excessive:</p> <ul style="list-style-type: none"> <li>o The reverse feed mechanism may fail to function.</li> </ul>

## 10. Installing the belt

If the belt has been removed during machine disassembly or on other occasions, re-install the belt referring to the following figure.

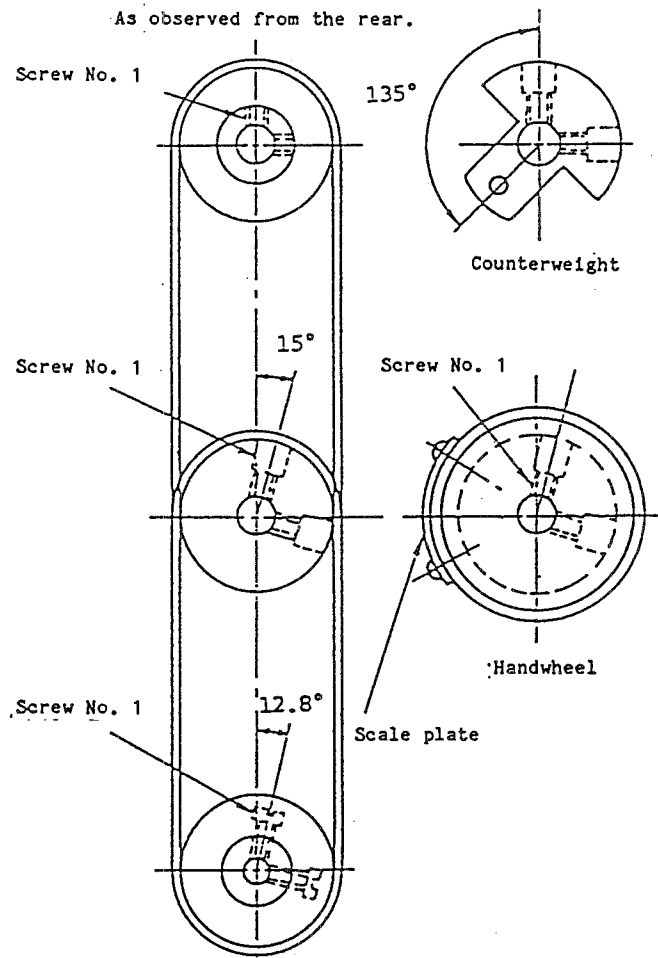

Fig. 30

The teeth on the sprocket wheel are spaced at every 30° angle of change, so use the teeth as angle indicators.



HOW TO ADJUST

RESULTS OF IMPROPER  
ADJUSTMENT

1) Upper belt

Install the upper belt so that setscrew No. 1 comes in front of the operator when the needle bar rises 9 mm (0.354") from the lowest position of its stroke.

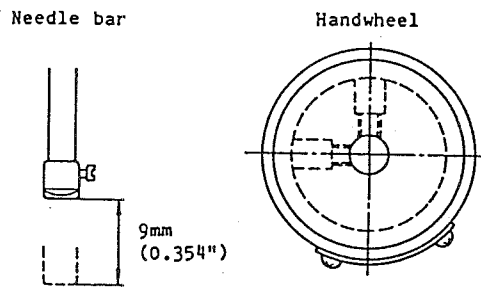

Fig. 31

2) Lower belt

Install the lower belt so that screw No. 1 in the handwheel and screw No. 1 in the lower sprocket both come more or less in front of the operator.

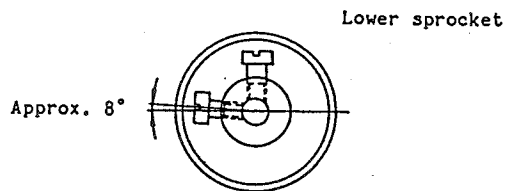

Fig. 32

o If the belt is not properly installed, the value indicated on the scale plate of the handwheel will be different from the actual feed amount of the sewing machine.

## 11. Safety mechanism

If the thread is caught in the shuttle during operation, the safety mechanism will be actuated, and the rotation of the shuttle will be separated from that of the handwheel.

## (1) Releasing the safety mechanism

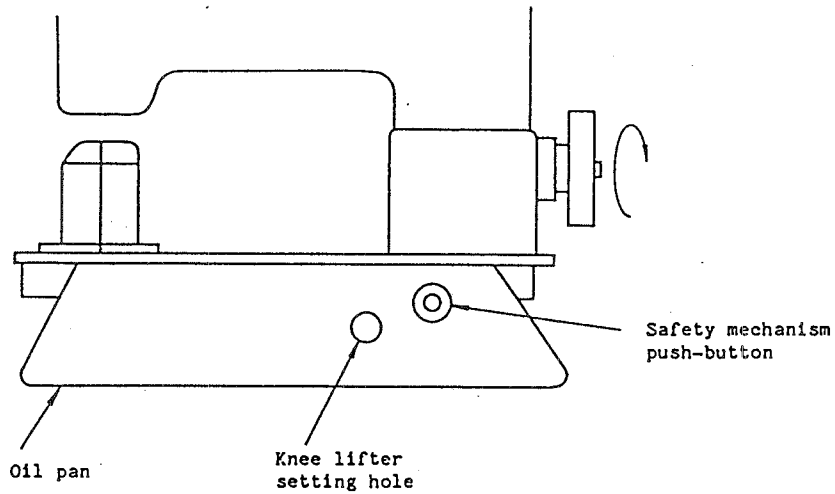

Fig. 33

## (2) Adjusting the pressure of the safety mechanism

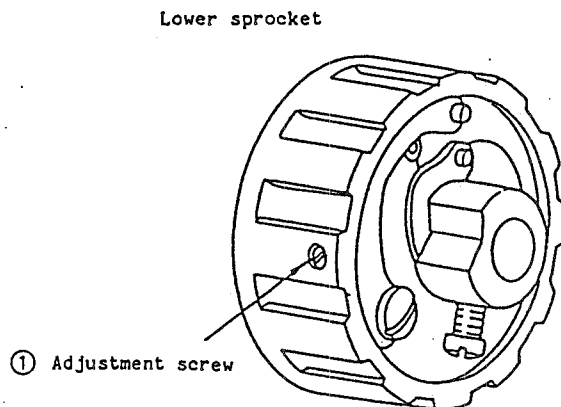
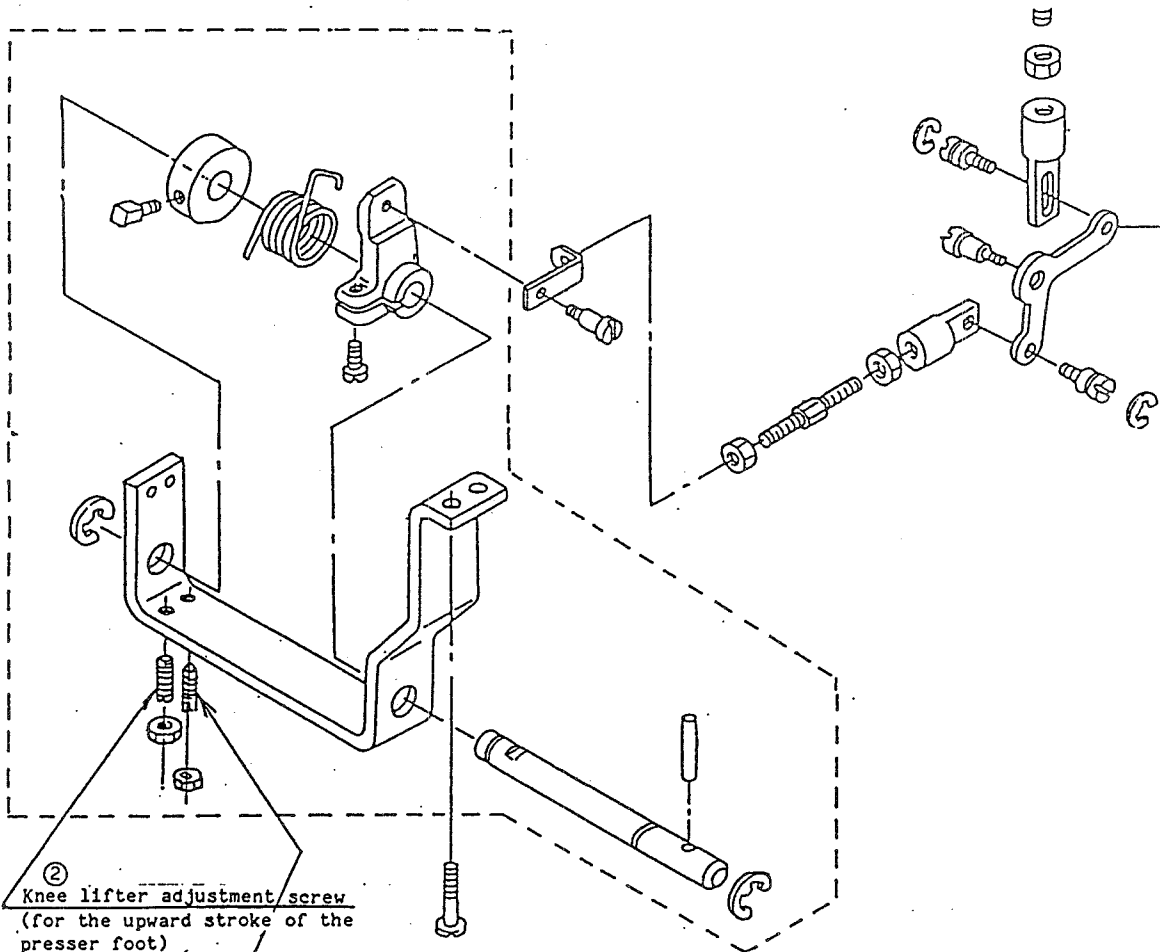

Fig. 34

HOW TO ADJUST	RESULTS OF IMPROPER ADJUSTMENT
<p>(1) Releasing the safety mechanism</p> <ol style="list-style-type: none"> <li>1) Tilt the sewing machine head.</li> <li>2) Turn the handwheel in the reverse direction (in the direction of the arrow) with the safety mechanism push-button held down, thereby resetting the safety mechanism.</li> <li>3) Raise the sewing machine head back into place.</li> </ol> <p>(Caution) The sewing machine head is heavy, so be careful when you tilt it.</p>	
<p>(2) Adjusting the pressure of the safety mechanism</p> <p>To re-adjust the pressure of the safety mechanism (when it is difficult to release the pressure and vice versa), remove the timing belt and make the adjustment using adjustment screw ①.</p> <ol style="list-style-type: none"> <li>1) Tighten adjustment screw ①, and the pressure of the safety mechanism will be increased. If the adjustment screw is loosened, the pressure of the safety mechanism will be decreased.</li> <li>2) The releasing torque of the safety mechanism is factory-adjusted to 210 kg/cm <math>\pm</math>20 kg/cm.</li> </ol>	

## 12. Knee lifter

The presser foot is factory-adjusted to go up as high as 9 mm (0.354") from the top surface of the throat plate when using the knee lifter.



② Knee lifter adjustment screw  
(for the upward stroke of the  
presser foot)

① Knee lifter adjustment screw  
(for the downward stroke of  
the presser foot)

Fig. 35

HOW TO ADJUST	RESULTS OF IMPROPER ADJUSTMENT
<p>1) Loosen the nut on the knee lifter adjustment screw. Adjust the position of knee lifter adjustment screw ① (on the right-hand side) to provide the knee lifter. Tighten the nut on the knee lifter adjustment screw.</p> <p>2) Loosen the nut on the knee lifter adjustment screw. Adjust the position of knee lifter adjustment screw ② (on the left-hand side) so that the presser foot goes up as high as 9 mm (0.354"). Tighten the nut on the knee lifter adjustment screw nut.</p>	<p>o If the play provided is inadequate, the presser foot may fail to firmly press the material during the sewing.</p>

STANDARD ADJUSTMENTS

1. Sewing conditions when using andaria thread

(1) Timing between the needle and the shuttle

1) Rising amount of the needle

2) Positioning of the needle and the blade point of the shuttle

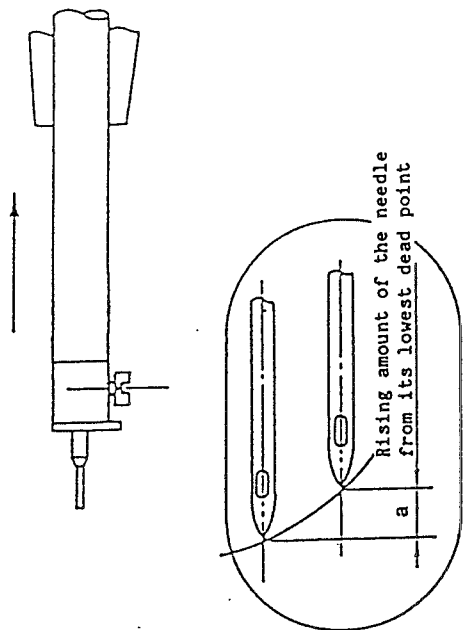

Fig. 36

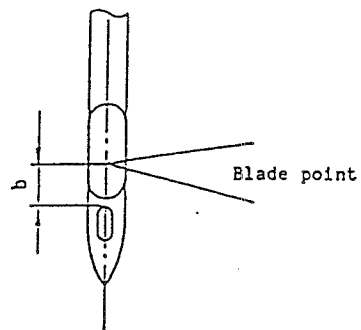

Fig. 37

Distance a: Rising amount of the needle	Point b: Position of the blade point
1.9+0.2mm (0.075"±0.008")	0.8+0.2mm (0.031"±0.008")

3) Effective amount of the protruding needle guard

4) Clearance between the needle and the blade point of the shuttle

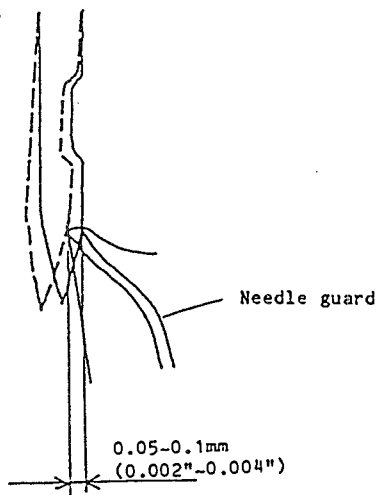

Fig. 38

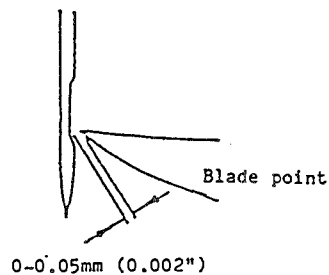

Fig. 39

Conditions

- o The needle bar goes up from the lowest dead point of its stroke.

HOW TO ADJUST	RESULTS OF IMPROPER ADJUSTMENT
<ul style="list-style-type: none"> <li>o Adjust the timing between the needle and the shuttle to obtain the standard timing for andaria thread, referring to "2. Timing between the needle and the shuttle" on page 7.</li> <li>o Thread stand               <ol style="list-style-type: none"> <li>1) Position arm B (asm.) of the thread stand as far away as possible from thread stand B.</li> <li>2) Put a net over the reel of andaria thread, and placing the net opening above the reel.</li> <li>3) Attach a bushing on section (A) of arm B (asm.) of the thread stand, and pass the thread through the bushing, as illustrated in Fig. 41.</li> </ol> </li> </ul>	<p>Stitch skipping, thread breakage or an uneven material feed may result.</p>

5) Thread stand

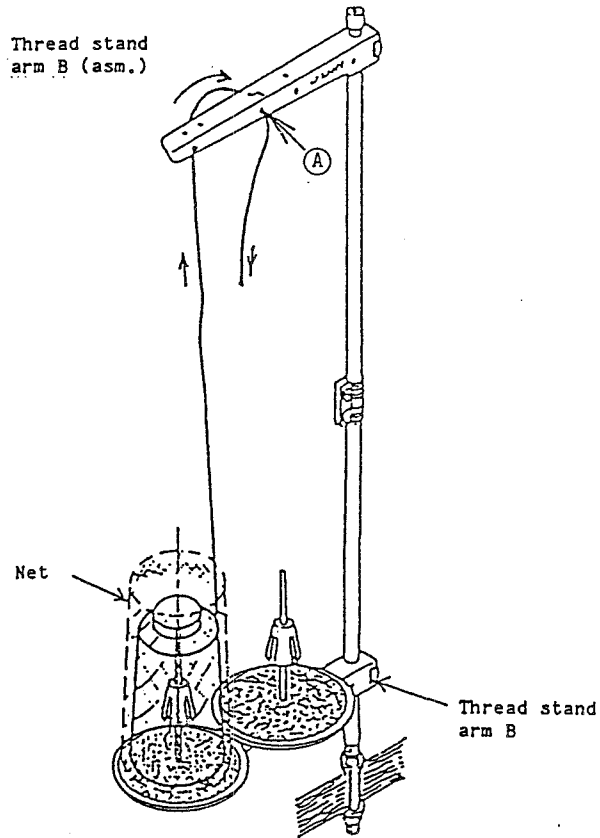

Fig. 40



HOW TO ADJUST

RESULTS OF IMPROPER  
ADJUSTMENT



4. Troubleshooting during a sewing o]

Problem	Test report
---------	-------------

1. Thread breakage

tle using  
n the throat

The thread frays or becomes worn out.

guide" on

d the blade

. (This  
ead.)

The 2 to 3 cm (0.787" to 1.181")  
needle thread remains on the  
wrong side of the material.

ing.

2. Stitch skipping

d the blade

shuttle" on

ge 5.

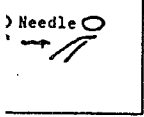

ing needle

: number

ad the

age 19.

o When sewing leather material, run the machine at normally from 800 to 1,600 s.p.m.

o When sewing a soft type of material, decrease the clearance so that it is smaller than the standard adjustment.

o When sewing a soft type of material, adjust the height of the bottom roller so that it is positioned lower than the standard adjustment.

Defect	Corrective measure	Test report
--------	--------------------	-------------

	Re-thread the bobbin.
--	-----------------------

thread	Grind the thread path using a sheet of fine emery paper or buff the thread path.
--------	--

Check how the thread is fed	Replace the bobbin or the shuttle.
-----------------------------	------------------------------------

	Refer to "3. Shuttle guide" on page 11.
--	---

throat plate	Loosen the upper bushing of the shuttle driving shaft to change the height of the shuttle.
--------------	--

Thread jumps out of the needle	Replace the bobbin case or the shuttle.
--------------------------------	---

roller with	Refer to "6. Height of the bottom roller" on page 19.
	If loose stitches are observed after making the above adjustment, position the bottom roller 0.2 mm (0.008") lower than the standard height.

of the needle entry hole	Refer to "1.(1) Needle entry point" on page 3.
--------------------------	--

Problem	Test report
---------	-------------

4. Irregular stitches

ery paper or

that  
read.

take-up  
initial  
the thread

ving shaft to

ent" on

thread guide  
the length of

o Generally, if the needle thread flutters, the tension of the needle thread is inappropriate. The cause of such trouble is probably one of the following:  
 1) The clearance between the thread spreaders is too great.  
 2) The bobbin does not move smoothly. The needle thread will stop fluttering if the thread spreaders and bobbin are adjusted.

o Irregular stitches will be eliminated by adjusting the thread take-up spring so that the tension is set to a lower value and the stroke to a smaller value.  
 → The pressure of the needle thread tension spring can now be increased, and the needle thread will be pulled with consistency.





# JUKI

## JUKI CORPORATION

### HEAD OFFICE

2-1, 8-CHOME, KOKURYO-CHO,  
CHOFU-CITY, TOKYO, JAPAN

### BUSINESS OFFICE

23-3, KABUKI-CHO 1-CHOME,  
SHINJUKU-KU, TOKYO 160, JAPAN

CABLE : JUKI TOKYO

TELEX : J22967, 232-2301

PHONE : 03(205)1081

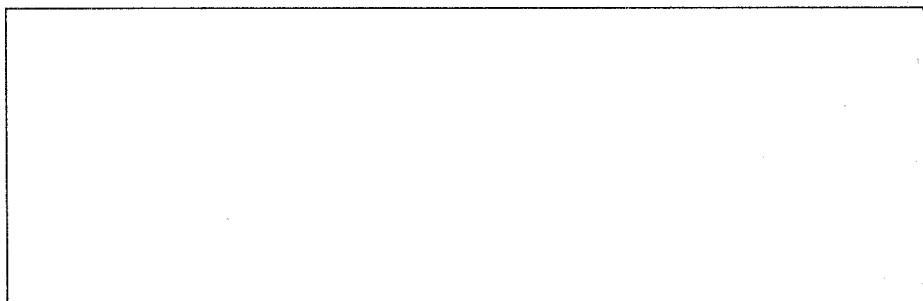

Printed in Japan (Y)