

1. SPECIFICATIONS

Model name	Needle-feed double chainstitch cylinder bed machine			
	2-needle			4-needle
Model	MH-1410A	MH-1410B	MH-1410C	MH-1410D
Stitch type	ISO standard 401			
Example of application	Waist band attaching of jeans, casual pants, etc.			
Max. sewing speed	5,000 rpm (Less than 4.5 mm pitch) 4,000 rpm (More than 4.5 mm pitch)			
Needle gauge of model	31.8mm (1-1/4")	34.9mm (1-3/8")	38.1mm (1-1/2")	6.4 – 25.4 – 6.4mm (1/4"–1"–1/4")
Needle height	10 to 10.2 mm			
Stitch length	2.1 to 6.4 mm			
Needle	ORGAN DV x 57 (62 x 57, SY3260, 5640) #18 to #25 (Standard #21)			
Needle bar stroke	32mm			
Dimensions	Width : 496 mm Length : 220 mm Height : 440 mm			
Periphery of cylinder	395 mm			
Weight	46 kg			
Lift of presser foot	9 mm			
Feed adjustment method	Push-button type Needle feed synchronizes with lower feed.			
Looper mechanism	Back and forth motion type (Longitudinal oscillation type) Looper pop-up (throw-out) at the time of threading type			
Lubricating system	Automatic lubrication by trochoidal pump			
Lubricating oil	JUKI New Defrix Oil No. 2 (Equivalent to ISO standard VG32)			
Oil reservoir capacity	900m ℓ			
Installation	Installation on the top surface of table			
Noise	Workplace-related noise at sewing speed n= 4500 min ⁻¹ : L _{PA} 85 dB (A) Noise measurement according to DIN 45635-48-A-1.			
Needle feed amount adjustment function	-5% to +25% of needle feed amount in terms of lower feed amount can be adjusted.			

Model name	Needle-feed double chainstitch cylinder bed machine (with mechanical cloth puller)
Model	MH-1410 / V072
Max. sewing speed	4000rpm
Dimensions	Width : 496 mm Length : 270 mm Height : 440 mm
Weight	50kg
Device feed adjustment method	Eccentric infinitely adjustable type

* Specifications which are not described above are common to those of the sewing machine head.

Auto-lifter	AK122 / Pneumatic drive type
-------------	------------------------------

2. CONFIGURATION OF THE MACHINE COMPONENTS

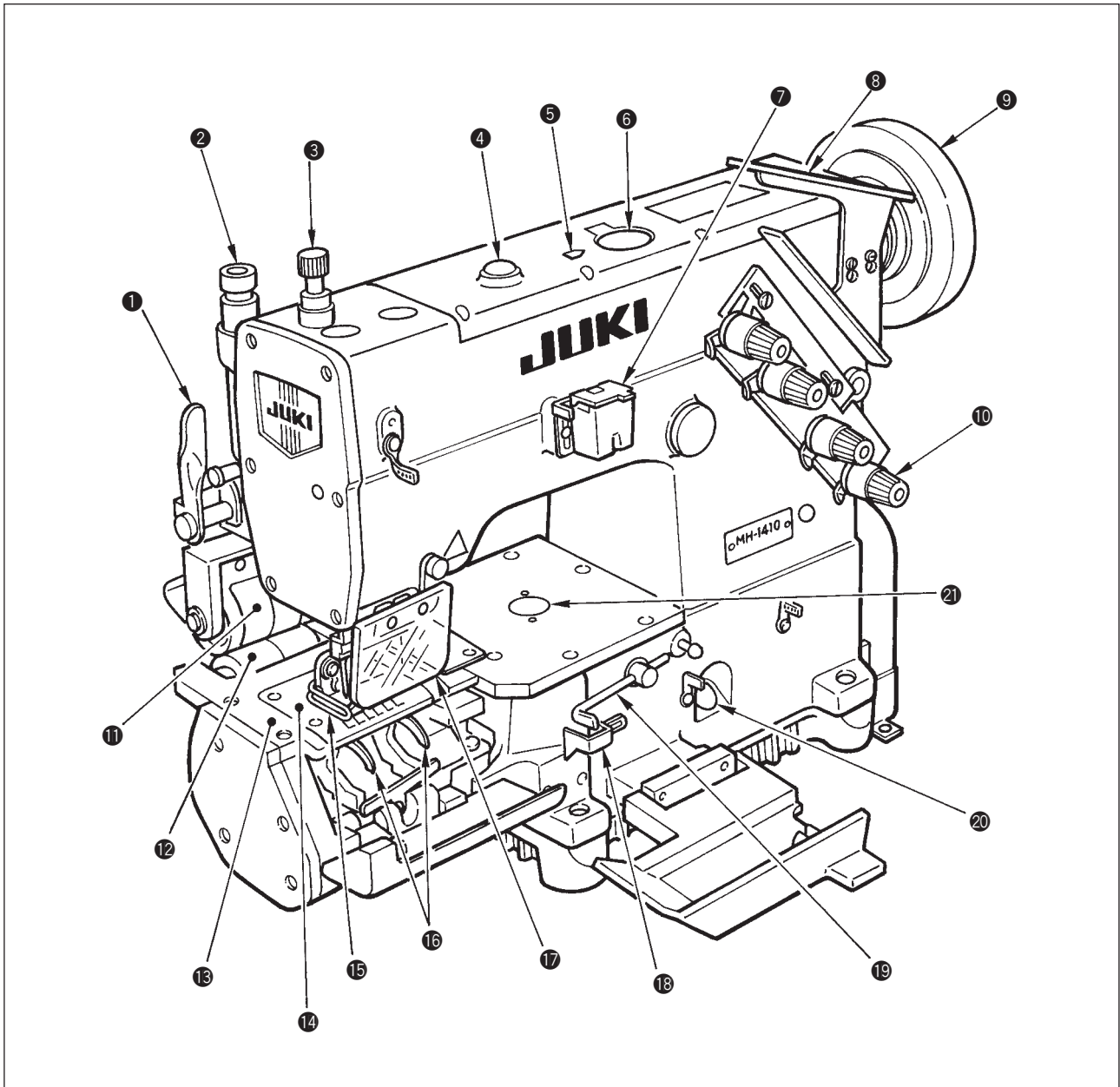

- | | | |
|------------------------------------|-----------------------|------------------------|
| ① Upper feed roller lifting lever | ⑧ Thread guide plate | ⑮ Finger guard |
| ② Roller press bar bushing (upper) | ⑨ Handwheel | ⑯ Loper |
| ③ Presser spring regulator | ⑩ Thread tension nut | ⑰ Eye guard cover |
| ④ Oil sight window | ⑪ Upper feed roller | ⑱ Loper thread eyelet |
| ⑤ "Oil" indication | ⑫ Lower roller | ⑲ Loper thread take-up |
| ⑥ Oil hole cap | ⑬ Throat plate holder | ⑳ Oil gauge |
| ⑦ Silicon oil lubricating unit | ⑭ Throat plate | ㉑ Push button |

- ① Upper feed roller lifting lever
Lever to raise or lower cloth puller (V072)
- ② Roller press bar bushing (upper)
Screw to adjust the pressure of upper feed roller
- ③ Presser spring regulator
- ④ Oil sight window
Window to check lubrication during operation of the sewing machine
- ⑤ "OIL" indication
Mark to show oil hole
- ⑥ Oil hole cap
Remove this cap to lubricate when lubricating.
- ⑦ Silicon oil lubricating unit
This unit is used to prevent thread from thread breakage or stitch skipping in case of high speed sewing or using synthetic thread.
- ⑧ Thread guide plate
- ⑨ Handwheel
- ⑩ Thread tension nut
- ⑪ Upper feed roller
- ⑫ Lower roller
- ⑬ Throat plate holder
- ⑭ Throat plate
- ⑮ Finger guard
Guard to prevent human body (mainly fingers) from coming in contact with needle.
- ⑯ Looper
- ⑰ Eye guard cover
Cover to prevent human body (mainly eyes and face) from coming in contact with needle due to needle breakage
- ⑱ Looper thread eyelet
This is used when adjusting the draw-out amount of thread with looper.
- ⑲ Looper thread take-up
This is used when adjusting the draw-out amount of thread with looper.
- ⑳ Oil gauge
Gauge to check oil
- ㉑ Push button
Button to change feed amount

3. STANDARD ADJUSTMENT

(1) Timing between the upper shaft and the lower shaft

Standard Adjustment

- Turn the handwheel ① to adjust marker pin ② to "P" on the handwheel ①. (Needle is placed at the upper dead point position.)

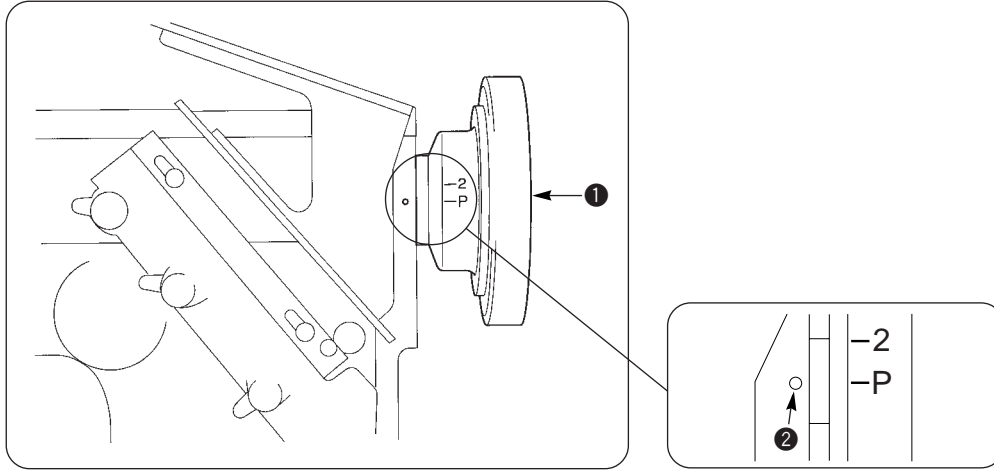

- It is standard that the line of the edge of lower shaft is vertical and the setscrew No. 1 in the direction of rotation of the machine pulley of the sewing machine is above when the needle bar is in the upper dead point position.

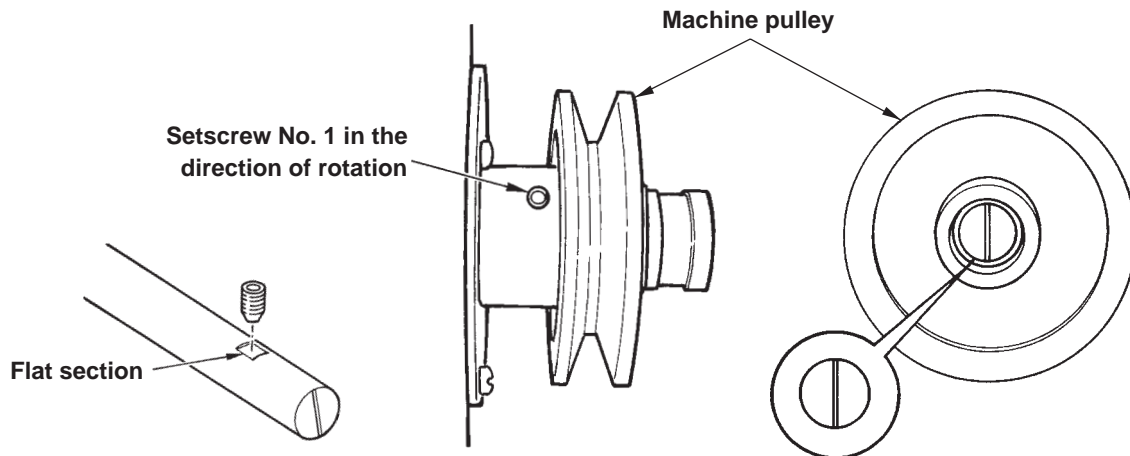

- Remove the top cover.
(Four setscrews ⑤ are used to tighten.)

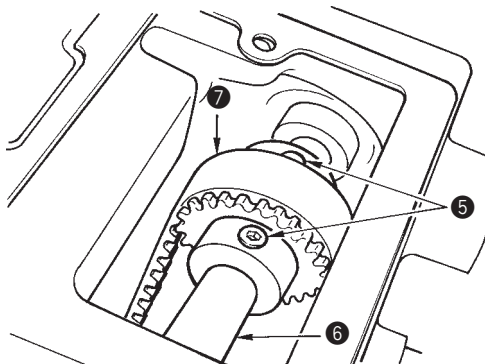

Adjustment Procedures	Results of Improper Adjustment
<ol style="list-style-type: none"> 1. Loosen seven top cover setscrews and remove the top cover. 2. Loosen four setscrews ⑤ in the timing belt pulley of upper shaft ⑥. 3. Turn timing belt pulley ⑦ with upper shaft ⑥ fixed and tighten four setscrews ⑤ in the timing belt pulley at the position where the line of the edge of lower shaft is vertical and the setscrew No. 1 of setscrews in the direction of rotation of the machine pulley of the sewing machine is above. 4. To check again, turn handwheel ① and check the line of the edge of lower shaft at the upper dead point position of the needle. 5. Attach the top cover which has been removed. 	<ul style="list-style-type: none"> ○ If the timing between the upper shaft and the lower shaft is improper, stitch skipping, thread breakage or needle breakage may be caused.

(2) Adjusting the height of the needle bar

Standard Adjustment

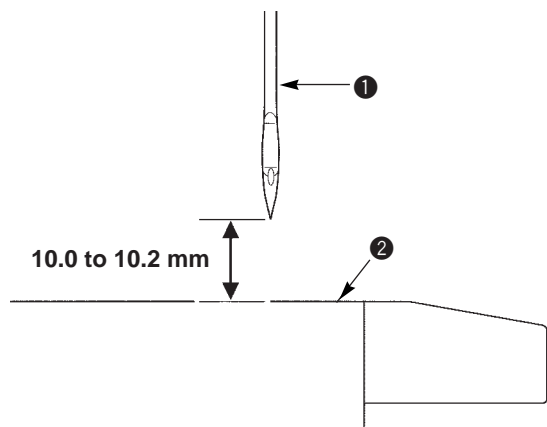

<Checking procedure>

- 1) Remove the presser foot.
- 2) Turn the handwheel to place needle ① to its upper dead point position.
- 3) Measure the dimension from top surface ② of the throat plate to the needle tip and check that it is 10.0 to 10.2 mm.

- Remove rubber cap ③ in the face plate.

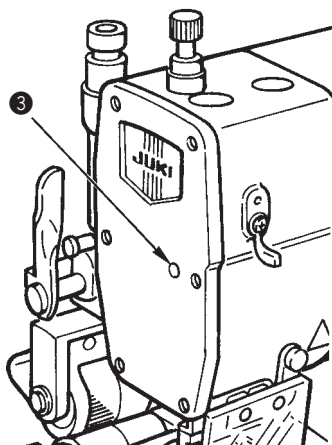

- Loosen the screw with the slit screwdriver.

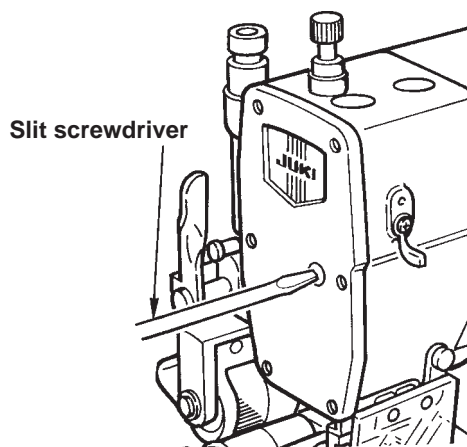

- Adjusting the parallelism

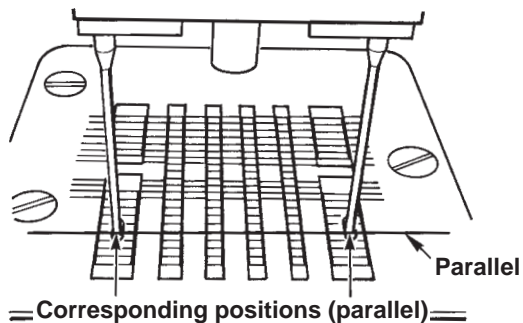

Adjustment Procedures	Results of Improper Adjustment
<ol style="list-style-type: none"> 1. Remove rubber cap ③ in the face plate. 2. Turn the handwheel to place the needle bar at its upper dead point position and loosen the needle bar bracket screw from the hole where rubber cap ③ is removed with the slit screwdriver. 3. Adjust the needle bar up or down so that the dimension from the top surface of throat plate ② to the needle tip is 10 to 10.2 mm, and temporarily tighten the needle bar bracket screw. 4. Turn the needle bar and adjust so that all needle tips of 2-needle or 4-needles enter the corresponding positions (parallel) of the needle holes of the feed dog when turning the handwheel and the needle tips enter the needle holes of the feed dog. Then tighten the needle bar bracket screw. 5. Attach rubber cap ③. 	<ul style="list-style-type: none"> ○ Stitch skipping or needle breakage may be caused unless the needle tips are in the same position (parallel).

(3) Adjusting the feed dog

Standard Adjustment

1) Adjusting the lateral direction of the feed dog

2) Adjusting the longitudinal direction of the feed dog

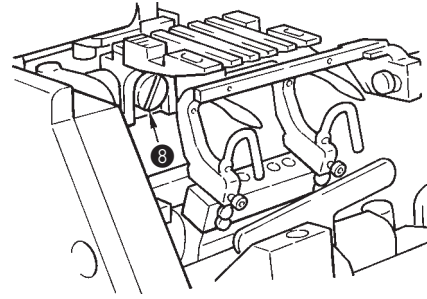

- Dimension of **A** and **B** is the same and **A** and **B** should be parallel.

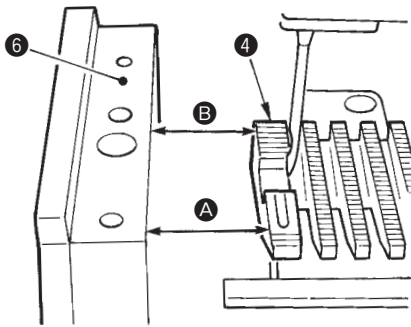

- When dimension of **A** and **B** is not parallel, loosen setscrews **1** in the feed dog to adjust.

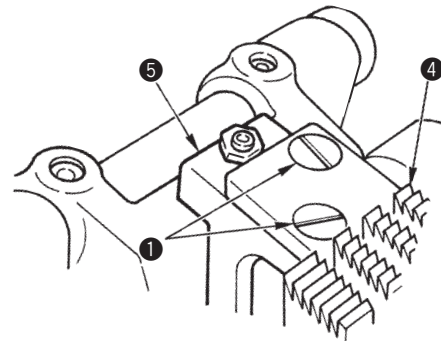

- Adjusting longitudinal/lateral position of the feed dog (For the standard machine, remove cylinder cover (rear) and for V072, remove the lower roller.)

- Lateral position of the feed dog

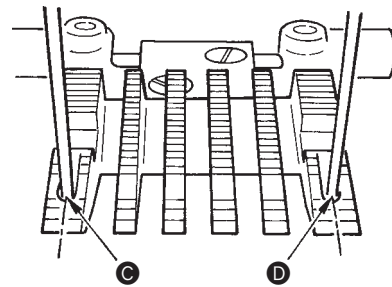
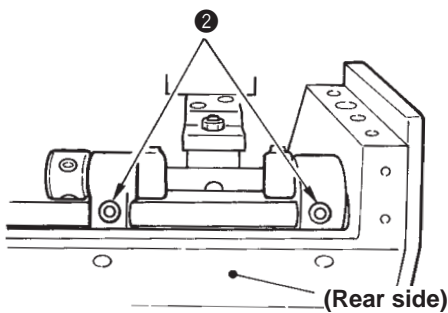

- Clearance **E** should be parallel and equal.

- Clearance between the rear of feed dog and the throat plate

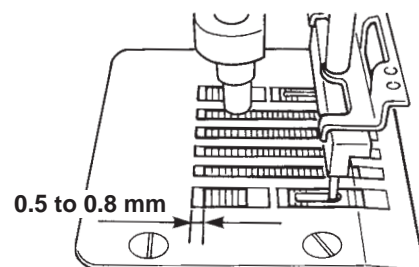
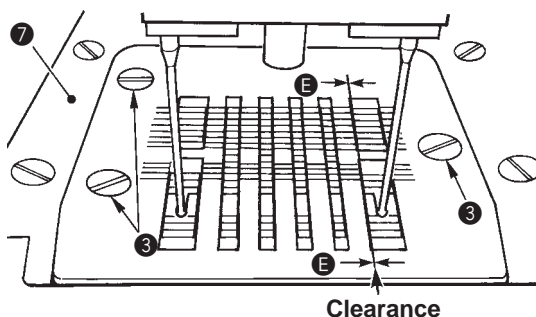

Adjustment Procedures	Results of Improper Adjustment
<p>1) Adjusting the lateral direction of the feed dog</p> <ol style="list-style-type: none"> 1. Remove throat plate holder ⑦ (with throat plate) using four setscrews, and check whether feed dog ④ is assembled parallel to feed dog holder ⑤. Checking procedure is that the distances ① and ② between the left edge of bed ⑥ and the front and rear of the left edge of feed dog ④ are the same and parallel. 2. If they are not parallel, loosen two setscrews ③ in the feed dog to adjust the parallelism, and tighten two setscrews ③ in the feed dog. <p>(Caution) When tightening setscrews ③ in the feed dog, remove feed dog ④ together with feed dog holder ⑤ using setscrew ④ and fix feed dog holder ⑤. Then tighten setscrews ③ in the feed dog.</p> <ol style="list-style-type: none"> 3. After fixing feed dog ④, install feed dog holder ⑤, and fix it with setscrew ④. 4. Remove four setscrews in the cylinder cover (rear) to perform the adjustment of lateral and longitudinal directions of the feed. (In case of the machine with V072, remove the lower roller.) 5. Loosen two setscrews ⑤ in the feed base to perform the adjustment of lateral and longitudinal positions of the feed dog. 6. Adjust the lateral position of the feed dog so that needles enter in the center of ③ and ④, needle entry of the feed dog. Then temporarily tighten setscrews ⑤ in the feed base. (The same for 4-needle machine) 7. Attach the throat plate and determine the position of the throat plate. (Attach the throat plate together with throat plate holder ⑦ while temporarily tightening three setscrews ⑥ in the throat plate.) 8. Turn the handwheel and move the throat plate so that the clearance between the feed dog and the groove of the throat plate should be parallel ⑤ and equal. Then tighten setscrews ⑥ in the throat plate. <p>(Caution) It is difficult to tighten one of setscrews ⑥ in the throat plate. Remove the throat plate together with the throat plate holder ⑦ and tighten the setscrews ⑥ in the throat plate.</p> <p>2) Adjusting the longitudinal direction of the feed dog</p> <ol style="list-style-type: none"> 1. Attach the throat plate to adjust the longitudinal direction of the feed dog. 2. To adjust the longitudinal direction of the feed dog, change the feed amount to the maximum. <p>(Caution) If the feed dog is positioned in the front direction, the spreader comes in contact with the loop deflector located in the wrong side of the feed dog. As a result, the spreader may break.</p> <ol style="list-style-type: none"> 3. When the feed amount is set to the maximum, provide a clearance of 0.5 to 0.8 mm between the rear of the feed dog and the throat plate, and fix the feed dog with setscrews ⑤ in the feed base. <p>(Caution) Turn the handwheel and check that there is no contact between the feed dog and the throat plate. At the same time, check the lateral position and the direction to check that there are equal lateral clearances.</p> <ol style="list-style-type: none"> 4. When the longitudinal and lateral positions have been determined, remove throat plate holder ⑦ with the throat plate, and tighten setscrews ⑥ in the throat plate which have been temporarily tightened to fix the throat plate. 5. Attach the cylinder cover (rear) which has been removed. 6. Return the feed amount which has been changed to the maximum to the proper feed amount. 7. Attach throat plate holder ⑦. 	<ul style="list-style-type: none"> ○ Needle breakage or stitch skipping will be caused. ○ Breakage of the spreader pin will be caused due to the contact of the spreader pin and the feed dog.

(3) Adjusting the feed dog

Standard Adjustment

3) Adjusting the height of the feed dog

- Loosen feed dog holder setscrew ①.

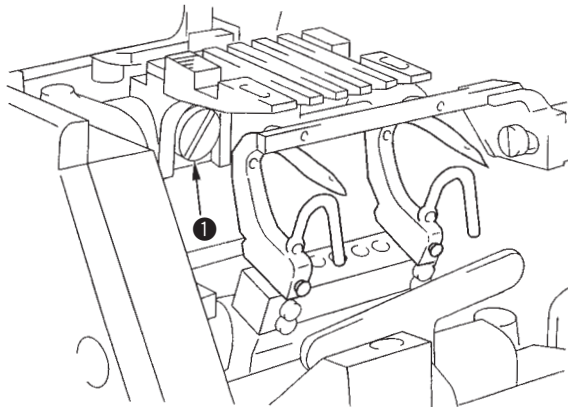

- Loosen feed dog height adjusting screw ② and nut ③ to adjust the height.

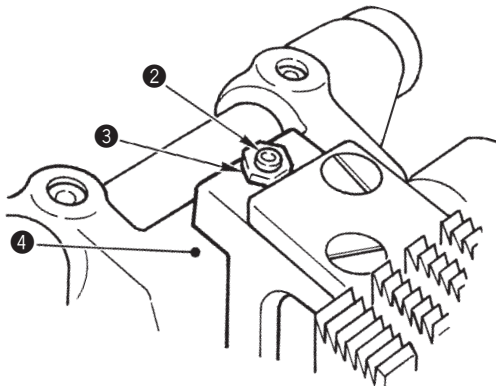

4) Adjusting the tilt of the feed dog

- When the feed dog goes up to its highest position.

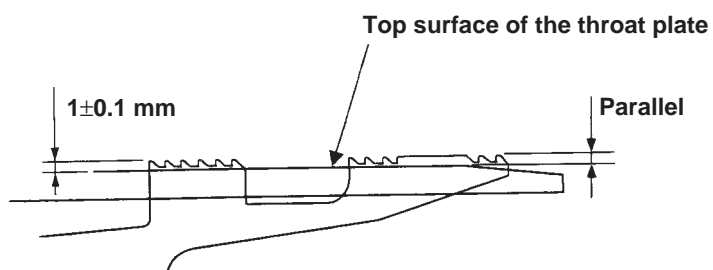

- Remove screw ⑤ in the adjusting hole.

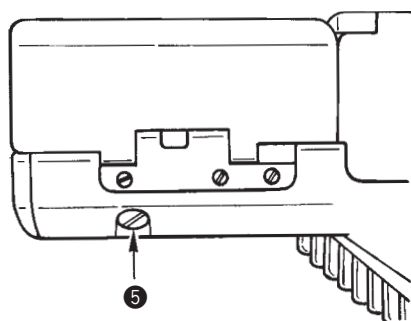

Adjustment Procedures	Results of Improper Adjustment
<p>3) Adjusting the height of the feed dog</p> <ol style="list-style-type: none"> 1. Remove needle, presser foot and throat plate holder (with throat plate). 2. Loosen feed dog holder setscrew ❶, feed dog height adjusting screw ❷ and nut ❸. 3. Attach the throat plate holder (with throat plate). 4. Adjust so that the height of the feed dog is 1 ± 0.1 mm from the top surface of the throat plate when the feed dog goes up to its highest position. Then fix it with feed dog holder setscrew ❶. 5. Remove the throat plate holder (with throat plate). 6. Tighten feed dog height adjusting screw ❷ until it comes in contact with feed base ❹ and fix it with nut ❸. 7. Attach throat plate holder (with throat plate), needle and presser foot. <p>4) Adjusting the tilt of the feed dog</p> <ol style="list-style-type: none"> 1. Remove screw ❺ in the adjusting hole. 2. Loosen the hexagon socket head bolt located in the rear of the adjusting hole to adjust the tilt. 3. Adjust the tilt so that the top surface of the throat plate is parallel to the top surface of the feed dog when the feed dog goes up to its highest position. 4. After the adjustment, tighten the hexagon socket head bolt. <p>(Caution) When attaching screw ❺ in the adjusting hole, apply sealant to the screw for the remedy of oil leakage. (Commendable sealant : Three Bond 1212)</p>	<ul style="list-style-type: none"> ○ If the feed dog is raised excessively high, the return is performed before the feed dog sinks. As a result, a bad influence is given to the finish of sewing. ○ Chain-off thread is hard to come out. ○ If the feed dog is lower than the specified height, feed pitch is decreased.

(4) Adjusting the longitudinal position of the needle feed

Standard Adjustment

- Remove rubber cap **1**.

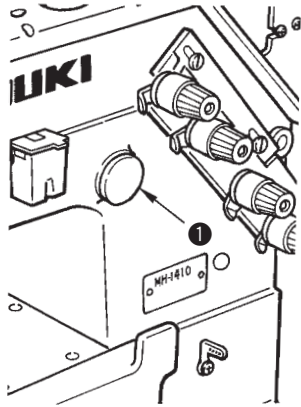

- Loosen setscrew **2** to adjust.

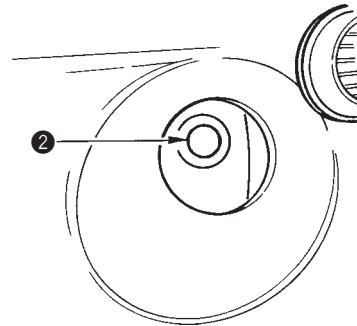

- Press push button **3**.

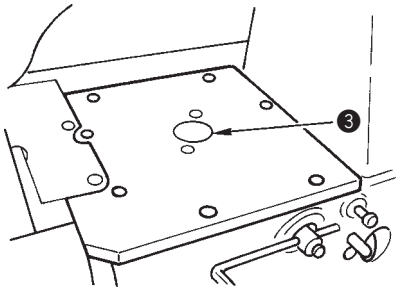

- Position of needle eyelet and feed dog

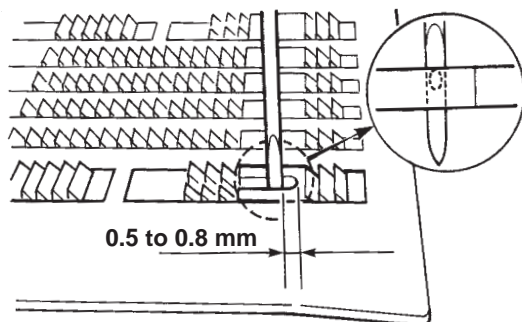

Adjustment Procedures	Results of Improper Adjustment
<ol style="list-style-type: none"> 1. Remove white rubber cap ❶ located in the front of the machine arm. 2. Change the feed amount to the maximum. (Press the push button and adjust the scale of handwheel to “L”.) 3. Turn the handwheel and adjust the needle eyelet to the position where it sinks to the needle hole of the feed dog. 4. Loosen setscrew ❷ in the needle rocker driving lever which is located in the rear where white rubber cap ❶ has been removed. 5. Provide a clearance of 0.5 mm to 0.8 mm from this side of needle hole of the feed dog to this side of needle at the position where the top end of needle eyelet is aligned with the top surface of feed dog and fix the needle rocker driving lever with setscrew ❷ in the needle rocker driving lever. <p>(Caution) To fix the needle rocker driving lever, move the needle rocker driving lever to the right or left and fix it with setscrew ❷ in the needle rocker driving lever at the position where it moves most lightly.</p> <ol style="list-style-type: none"> 6. Attach rubber cap ❶ and return the feed amount to the proper one. 	<ul style="list-style-type: none"> ○ When the adjustment value is excessively small, needle comes in contact with the feed dog and breakage of components may occur.

(5) Adjusting the differential needle feed

Standard Adjustment

- Remove cover **1** and packing **2** to adjust.

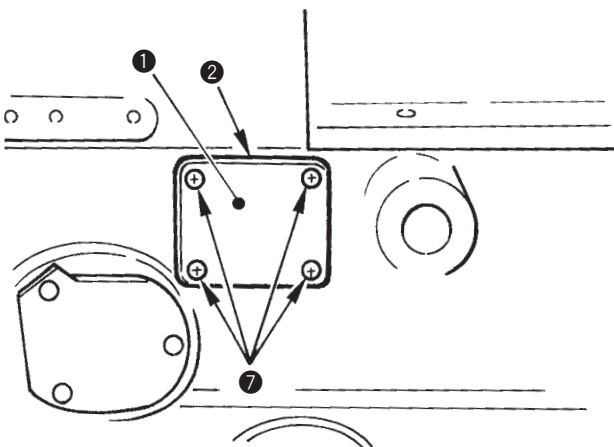

- The center of three engraved marker dots is the standard.

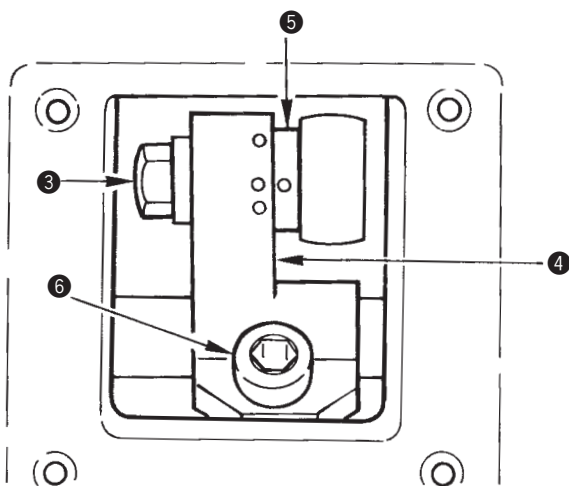

Adjustment Procedures	Results of Improper Adjustment
<p>1. Remove four setscrews ⑦ in adjusting slide cover ① and adjusting slide cover packing ② in the rear of the machine bed.</p> <p>2. There are needle rocker lever ④ and needle rocker lever pin ⑤ in the rear of the cover packing which has been removed. Loosen nut ③ fixing the lever pin.</p> <p>(Caution) Do not loosen setscrew ⑥ in the needle rocker lever.</p> <p>3. There are three engraved marker dots in needle rocker lever ④. When the engraved marker dot of needle rocker lever pin ⑤ is adjusted to the upper engraved marker dot, the needle rocking amount (differential feed ratio) in terms of the feed amount of the feed dog is increased by +25%, and when it is adjusted to the lower engraved marker dot, the needle rocking amount is decreased by -5%. (The engraved marker dot in the center is the standard, ±0%.)</p> <p>4. Adjust the needle rocking amount in accordance with materials, process and finish of sewing.</p> <p>5. After the adjustment, fix nut ③ which has been loosened and attach adjusting slide cover packing ② and adjusting slide cover ①.</p> <p>(Caution) If the needle rocking amount (differential feed ratio) is changed, the clearance between spreader and needle changes. Be sure to perform the adjustment of clearance. (Refer to the item “Adjusting the drawing amount of the spreader” described in the Instruction Manual.)</p>	<ul style="list-style-type: none"> ○ If the needle rocking amount (differential feed ratio) is excessively increased, belt is fed more. It is effective to prevent belt from waving. ○ If the needle rocking amount (differential feed ratio) is excessively decreased, belt is expanded and sewn up.

(6) Adjusting the timing between the needle and the looper

Standard Adjustment

○ Remove rubber cap ①.

○ Adjust the timing with adjusting screws ④.

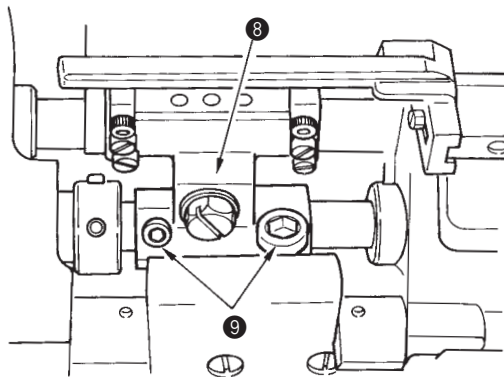
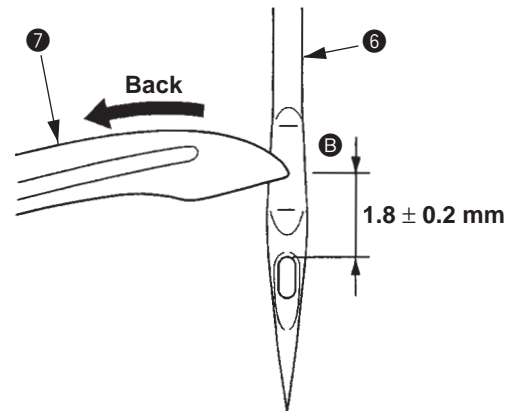
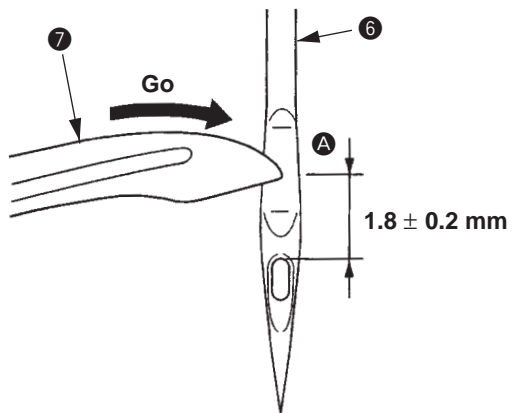
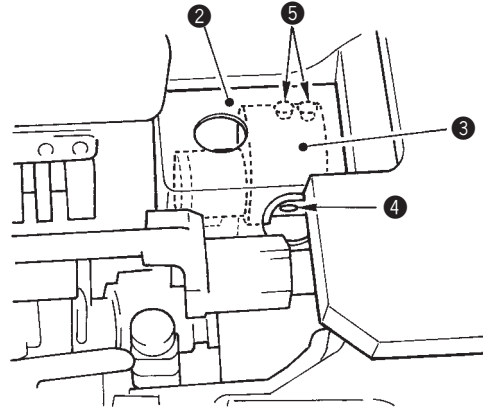
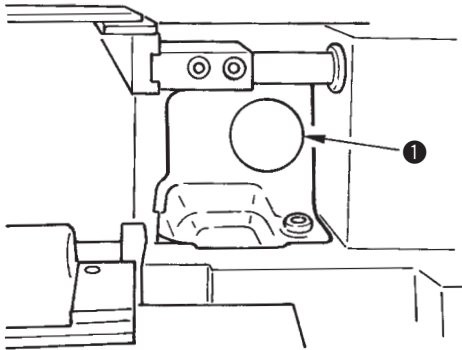

Adjustment Procedures	Results of Improper Adjustment
<p>(When stitch length is changed.)</p> <ul style="list-style-type: none"> ○ Turn the handwheel and make sure that needle ⑥ and looper ⑦ pass the same position when they go and back. <ol style="list-style-type: none"> 1) Remove rubber cap ①. 2) Loosen two setscrews ④ in looper eccentric ③, and temporarily tighten the setscrew No. 2 in the direction of rotation of setscrews ④ so that the looper eccentric ③ can be adjusted again. 3) Adjust so that the looper passes the same positions A and B (top end of looper is 1.8 ± 0.2 mm above from top end of needle eyelet) of needle ⑥ when the looper goes and back. 4) Adjust looper eccentric ③ and adjust the timing between the needle ⑥ and the looper ⑦. 5) After the adjustment, tighten setscrews ④ in looper eccentric ③ and adjusting range setscrews ⑤, and attach the rubber cap ①. <p>(Caution)</p> <ol style="list-style-type: none"> 1. If looper eccentric adjusting range setscrews ⑤ are excessively loosened, the looper eccentric ③ rotates and the adjusting range position shifts. 2. Do not remove cover ② since oil leakage will be caused. <ul style="list-style-type: none"> ○ Adjusting the drawing amount of the looper <ol style="list-style-type: none"> 1) Loosen two setscrews ⑨ in looper holder ⑧ and adjust the looper holder ⑧. Then adjust the longitudinal position of looper ⑦. 2) After the adjustment, tighten setscrews ⑨. 	<ul style="list-style-type: none"> ○ When go / back timing between needle and looper is not proper, stitch skipping or thread breakage will be caused.

(7) Adjusting the attaching angle of the looper

Standard Adjustment

- Remove cylinder cover ① and hinge ②.

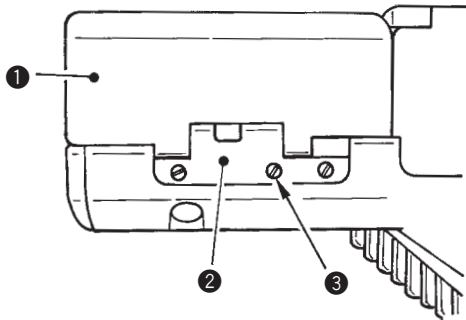

- Adjust attaching angle of loopers ④.

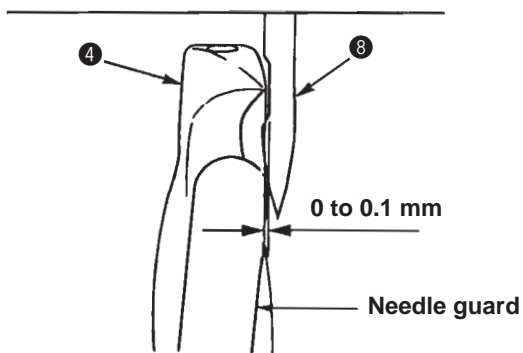
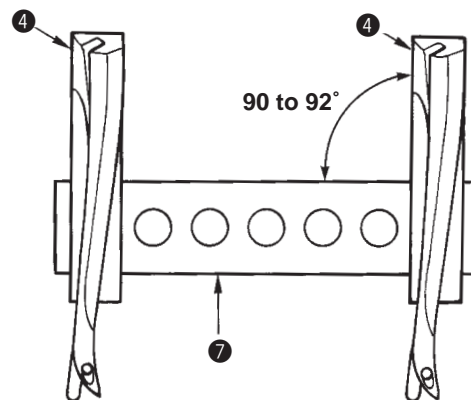
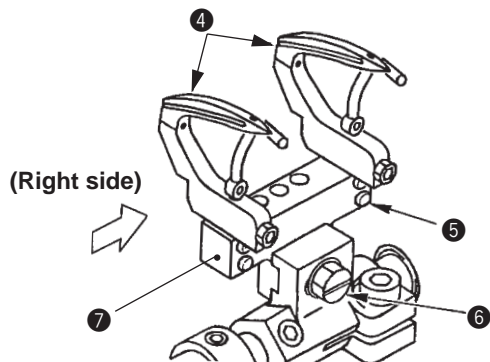

Adjustment Procedures	Results of Improper Adjustment
<ol style="list-style-type: none"> 1. Loosen three setscrews ③ and remove cylinder cover ① and hinge ②. 2. Adjust the angle of both of two (four) loopers ④ to 90° and temporarily tighten setscrews ⑤ in the loopers. 3. Loosen setscrew ⑥ in the looper holder and move looper holder ⑦ to the direction (right side) where the top end of loopers ④ approaches the needle. 4. First, adjust the angle of looper ④ of which the top end comes in contact with needle ⑧ to the direction of 92°. (Adjust the angle in the direction where the looper leaves the needle.) 5. Adjust looper holder ⑦ so that the clearances between the top ends of remaining loopers ④ (1 or 3 loopers) and needles ⑧ are 0 to 0.1 mm respectively and fix setscrews ⑤ and ⑥ in the loopers and the looper holder. 6. Adjust the angle of the looper of which the angle has been adjusted to the direction of 92° so that the clearance between the looper and needle ⑧ should be 0 to 0.05 mm, and fix looper ④. <p>(After the adjustment, attach cylinder cover ① and hinge ②.)</p>	<ul style="list-style-type: none"> ○ If the angle of the looper becomes larger (more than 92°), the looper and the loop deflector attached to feed dog may come in contact with each other. ○ If the angle of the looper becomes smaller (less than 90°), stitch skipping may be caused when the spreader catches looper thread at the time of return of the looper.

(8) Adjusting the clearance between the needle and the needle guard

Standard Adjustment

1. Needle ① comes in contact with needle guard ② by 0 to 0.05 mm when needle ① meets the top end of the looper.

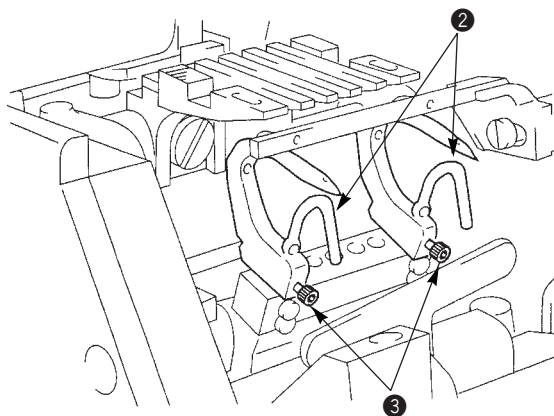
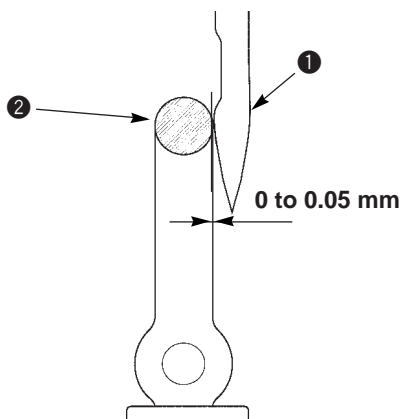

Adjustment Procedures	Results of Improper Adjustment
<p>1. Loosen setscrews ③ in the needle guards and turn needle guards ② to adjust the clearance. After the adjustment, tighten setscrews ③ in the needle guards.</p>	<ul style="list-style-type: none"> ○ When the needle used is a new one, but bent, adjust the needle guard to make it slightly work so that the top end of the looper does not come in contact with the needle even when replacing the needle. ○ When adjusting the needle guard, check again the position and angle (clearance between looper and needle) of the looper.

(9) Adjusting the spreader

Standard Adjustment

- Adjust spreader ⑤.

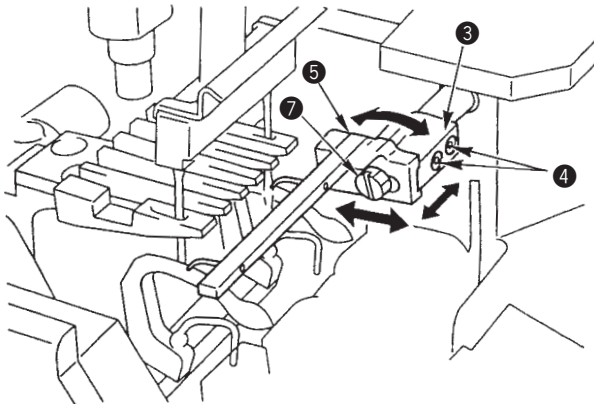

* Be sure to adjust the drawing amount of spreader ⑤ when making the stitch length more than 4 mm.

1) Adjusting the lateral position of the spreader

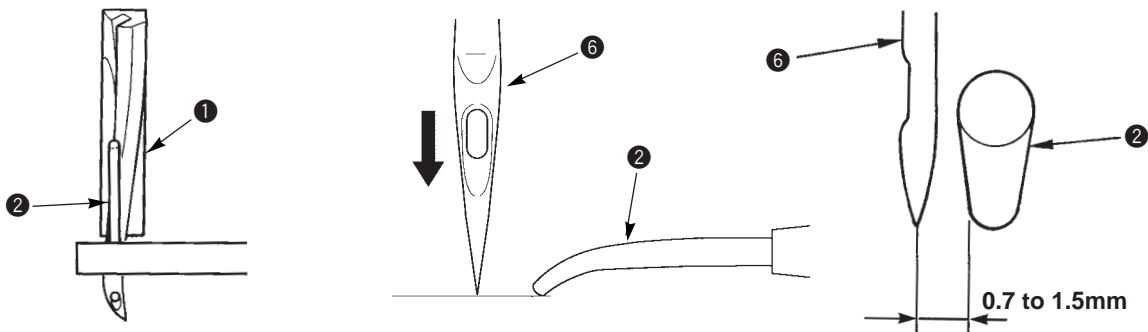

2) Adjusting the height of the top end of the spreader

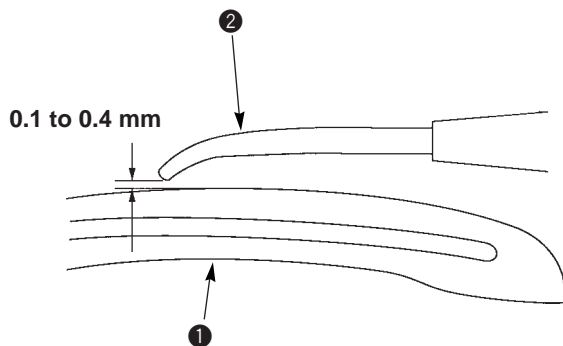

3) Adjusting the drawing amount of the spreader

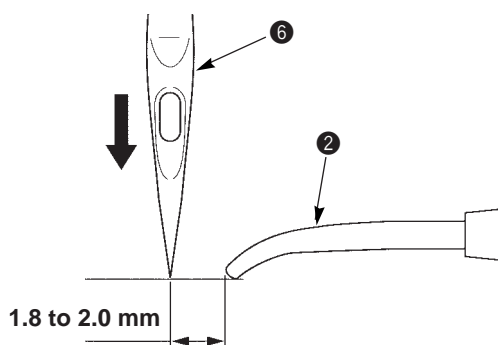

Adjustment Procedures	Results of Improper Adjustment
<p>1) Adjusting the lateral position of the spreader</p> <ol style="list-style-type: none"> To adjust the lateral position of spreader ⑤, adjust so that the top end of spreader pin ② is positioned between the edge line and the left side face of looper ① when looper ① comes to this side most. For the adjustment, loosen setscrews ④ in spreader base ③ and move spreader base ③ to the left or right (↔). After the adjustment, tighten two setscrews ④ in spreader base ③. <ul style="list-style-type: none"> ○ Make sure that when the top end of the needle and the top end of the spreader pin come to the same height when the needle comes down, the clearance between the top end of the needle and the left end (as observed from the front) of the spreader pin is more than the width of the spreader pin. When the top end of needle ⑥ is as high as that of spreader pin ② when needle ⑥ comes down, the clearance between the top end of needle ⑥ and the left side of spreader pin ② is approximately as large as the diameter (0.7 to 1.5 mm) of the top end of spreader pin ②. <p>2) Adjusting the height of the top end of the spreader</p> <ol style="list-style-type: none"> The standard value of the clearance between the top end of spreader pin ② and the top surface of looper ① is 0.1 to 0.4 mm when the top surface of the looper comes close most. Loosen two setscrews ④ in spreader base ③ and turn (arrow mark ↷) spreader base ③ to adjust the height. After the adjustment, tighten two setscrews ④. <p>3) Adjusting the drawing amount of the spreader</p> <ol style="list-style-type: none"> Adjust so that the clearance between the needle and the spreader pin should be 1.8 mm to 2.0 mm when the needle comes down and the top end of the needle ⑥ is as high as the top end of spreader pin ②. Loosen setscrew ⑦ in the spreader and adjust the spreader to and fro (↕). After the adjustment, tighten setscrew ⑦ in the spreader. <p>(Caution) When stitch length is changed, the clearance of 1.8 to 2.0 mm changes. When the stitch length is excessively changed, perform re-adjustment accordingly. (Perform the same adjustment when needle rocking amount (differential feed ratio) is changed.)</p>	<ul style="list-style-type: none"> ○ If spreader goes excessively to the right side, stitch skipping is apt to occur or chain-off thread is hard to come out when the spreader catches looper thread. ○ If spreader goes excessively to the left side, needle pierces looper thread or stitch skipping is apt to occur.

(10) Adjusting the spreader eccentric

Standard Adjustment

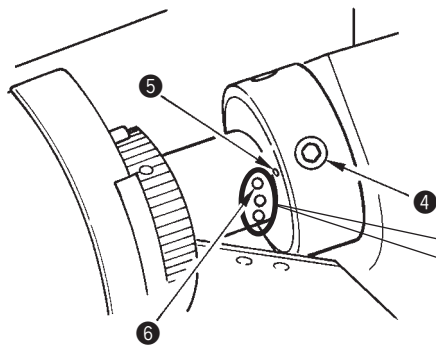
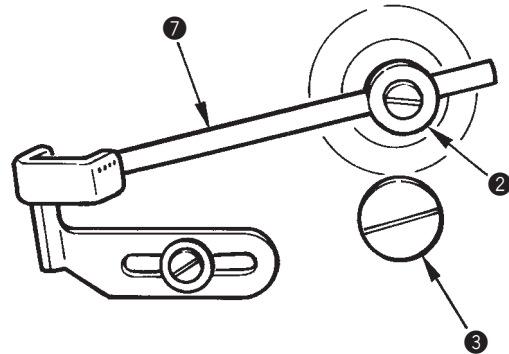
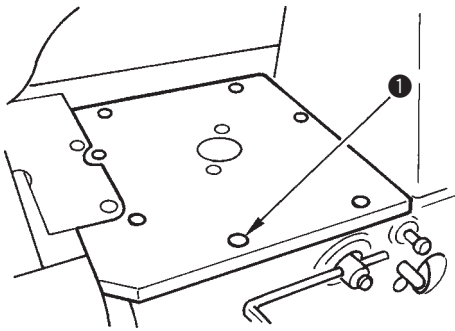

- Standard
- Slightly advanced
- Advanced

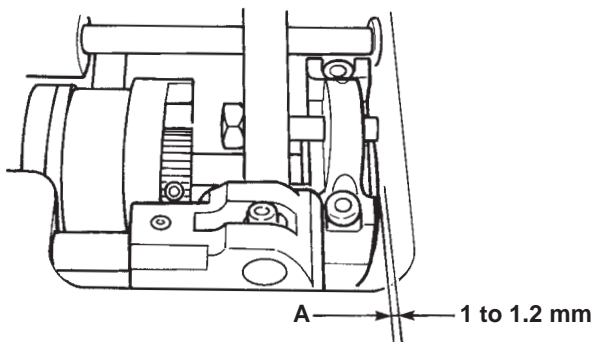

Adjustment Procedures	Results of Improper Adjustment
<p>Timing between the looper thread take-up and the needle</p> <ol style="list-style-type: none"> 1. Remove setscrews ❶ in the bed top cover and remove the top cover and the cover packing. (7 setscrews) 2. Remove adjusting hole screw ❸ under looper thread take-up shaft ❷. (Insert a hexagonal wrench key from the adjusting hole and adjust setscrew ❹ in the eccentric.) 3. The timing between looper thread take-up and spreader, or needle and looper changes by changing the position of marking ❺ (screw No. 1 in the rotating direction ❹) on the spreader eccentric and marking ❻ on the lower shaft. (Standard adjustment) Adjust the marking ❺ (standard) on the eccentric to marking ❻ located in the rear on the lower shaft. 4. Loosen setscrew ❹ in the eccentric. If the marking is adjusted to the front of the rotational direction, the timing of looper thread take-up ❷ and spreader in terms of needle and looper is advanced. 5. For assembling after the adjustment, tighten setscrew ❹ in the eccentric at the position where the clearance A between the spreader eccentric and the lower shaft bushing is 1 to 1.2 mm. <p>(Caution) 1. After this adjustment, be sure to adjust the timing of needle, looper and spreader. 2. After adjusting the eccentric, timing of looper thread take-up ❷ changes. Adjust the timing and change the looper thread tension as well.</p> <ol style="list-style-type: none"> 6. After the adjustment, attach the bed top cover, cover packing and adjusting hole screw ❸. (Apply sealant to the adjusting hole screw ❸ for the remedy of oil leakage.) (Commendable sealant : Three Bond 1212) <p>(Caution) Avoid an excessive change (exceeding the marking). Component breakage will be caused.</p>	<ul style="list-style-type: none"> ○ In case of advancing timing : <ol style="list-style-type: none"> 1) When timing is advanced, needle thread is tightened and looper thread become balloon. 2) When timing is excessively advanced, spreader comes in contact with looper. ○ In case of delaying timing : <ol style="list-style-type: none"> 1) Needle thread cannot be tightened and chain-off thread dose not come out. ○ When the position of the marking is changed, the stroke of the spreader changes and the sewing is affected.

(11) Adjusting the thread tension of looper thread

Standard Adjustment

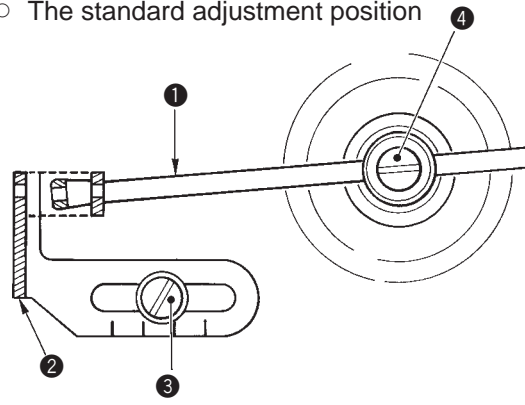
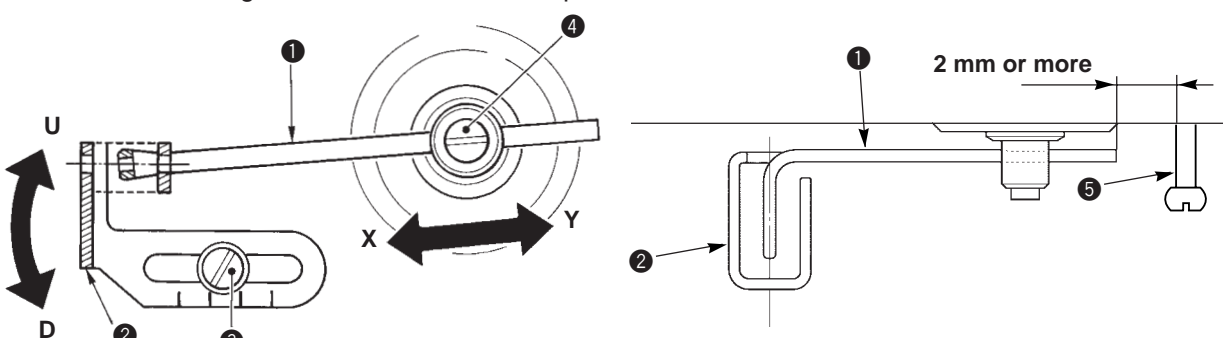
- The standard adjustment position 
- How to change the thread tension of looper thread 

(12) Adjusting the needle thread take-up

Standard Adjustment

- The standard is that the dimension between the center of setscrews **1** and that of the needle eyelets of needle thread take-up **2** is 11 to 13 mm.

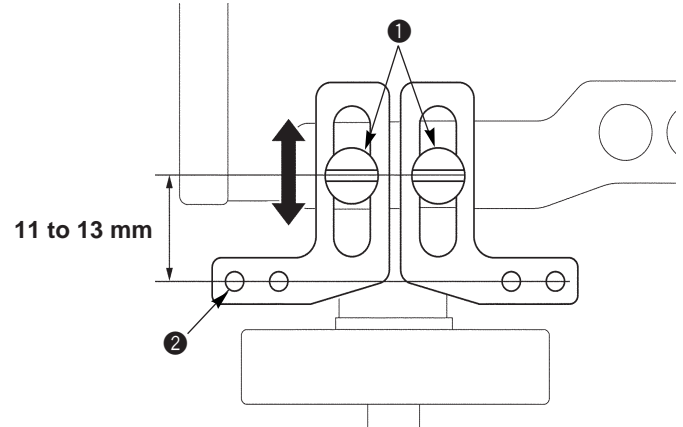

Adjustment Procedures	Results of Improper Adjustment
<ol style="list-style-type: none"> 1. Turn the handwheel to bring the needle bar to its upper dead point. 2. Loosen setscrew ③ and adjust so that the slot section of looper thread eyelet ② is flush. Then temporarily tighten setscrew ③ at the position of the center of slot. 3. Loosen setscrew ④ in looper thread take-up ① and tighten setscrew ④ at the position where looper thread take-up ① draws out thread in the center of looper thread eyelet ② as shown in the figure. 4. Make sure that looper thread eyelet ② is aligned with the thread hole of looper thread take-up ① and tighten setscrew ③ in the looper thread eyelet. (Before changing thread tension of looper thread, return the looper thread take-up to the position of the aforementioned adjustment and change the thread tension.) 5. When tightening looper thread in case of the change of thread tension, move looper thread take-up ① to the direction Y. When releasing looper thread, move looper thread take-up ① to the direction X. Adjust looper thread eyelet ② accordingly. <p>(Caution) When looper thread take-up ① is excessively moved to the direction Y, it comes in contact with pin ⑤ in the thread take-up cover. Make the clearance 2 mm or more accordingly.</p>	<ul style="list-style-type: none"> ○ When the looper thread eyelet is set to the direction U, looper thread is likely to be tightened and it is effective against irregular stitches. ○ When the looper thread eyelet is set to the direction U, increase needle thread tension since needle thread is drawn out. ○ When the looper thread eyelet is set to the direction D, looper thread is likely to be loosened. However, do not adjust it normally since irregular stitches will be caused.

Adjustment Procedures	Results of Improper Adjustment
<ol style="list-style-type: none"> 1. Loosen setscrews ① and adjust the installing position of needle thread take-up ② to 11 to 13 mm. After the adjustment, tighten setscrews ①. 	<ul style="list-style-type: none"> ○ When the needle thread take-up is lifted, needle thread is loosened. ○ When the needle thread take-up is lowered, needle thread is tightened. ○ It is more effective to tighten thread when the left needle thread take-up is lifted since the material on the left needle side is thick. <p>(Caution) When the needle thread tension is high, the aforementioned way of tightening the needle thread becomes the other way around.</p>

(13) Adjusting the loop deflector

Standard Adjustment

- Remove feed dog **2** together with the feed dog holder using setscrew **5**.

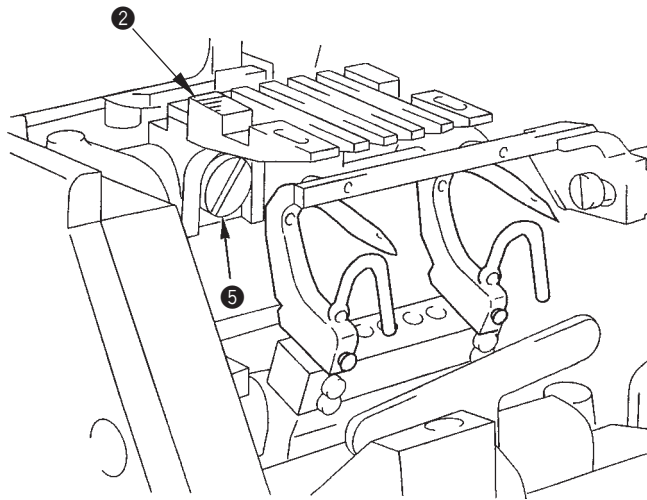

- The clearance between loop deflector **3** of feed dog **2** and needle **1** should be 0.8 mm.

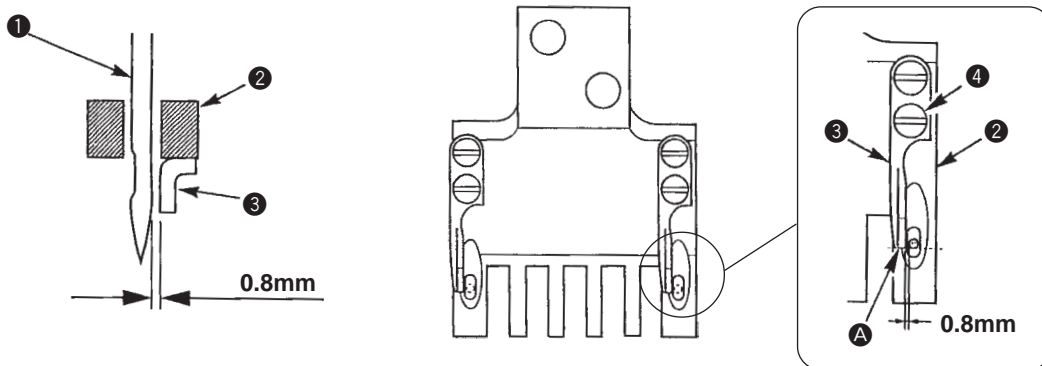

Wrong side of feed dog

- Adjust so that section **A** of the top end of loop deflector **3** is placed at the position where it does not protrude from needle **1**.

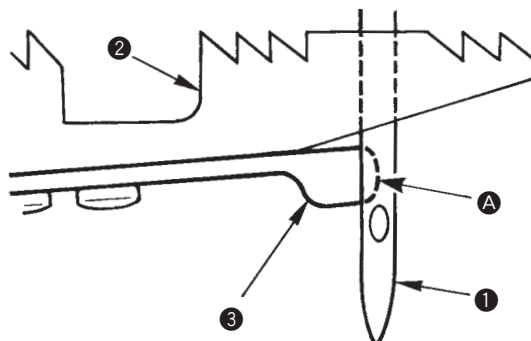

Adjustment Procedures	Results of Improper Adjustment
<ol style="list-style-type: none"> 1. Remove needle ①, presser foot and throat plate holder. 2. Remove feed dog ② together with the feed dog holder using setscrews ⑤. 3. Loosen and temporarily tighten setscrews ④ in the loop deflector. 4. Attach feed dog ② together with the feed dog holder using setscrew ⑤. 5. Attach needle ①, turn the handwheel to bring the needle to its lower dead point position and adjust so that section A of the top end of loop deflector A is placed at the position where it does not protrude from needle ①. 6. After the adjustment, remove feed dog ② together with the feed dog holder and tighten setscrews ④ in the loop deflector. 7. After fixing loop deflector ③, attach feed dog holder, throat plate holder and presser foot. 	

(14) Adjusting the height of the presser foot

Standard Adjustment

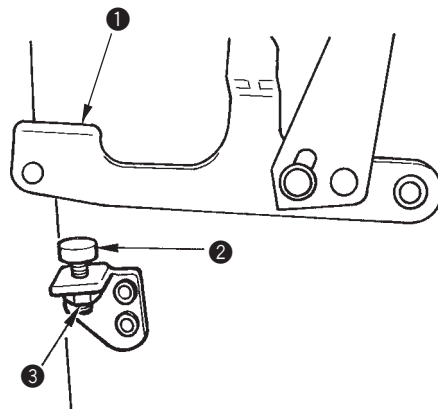
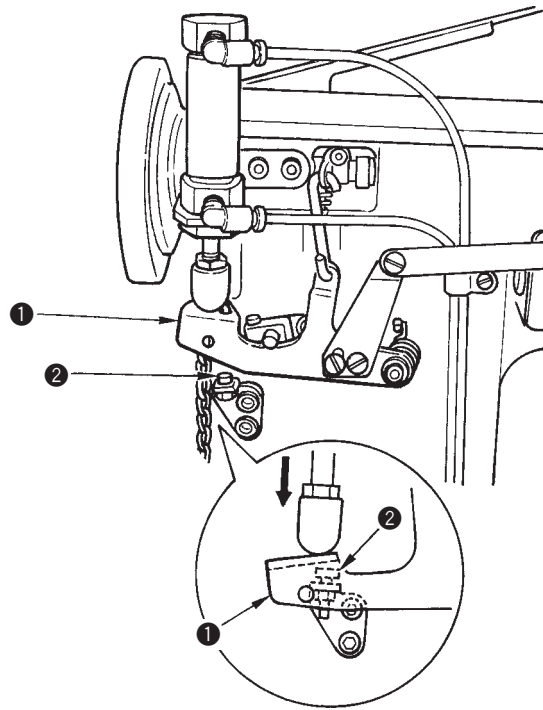
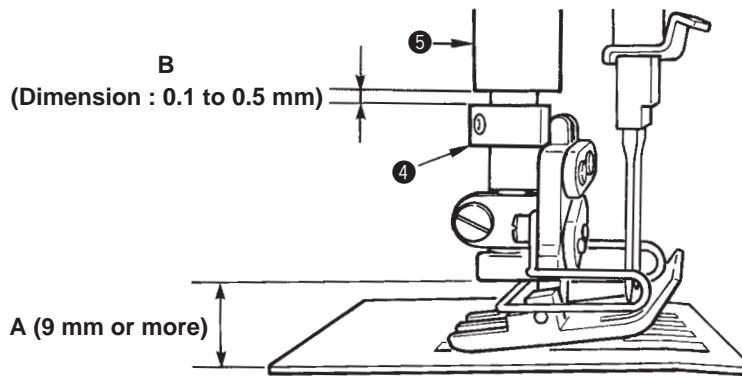

Adjustment Procedures	Results of Improper Adjustment
<ol style="list-style-type: none"><li data-bbox="172 264 938 376">1. Adjust presser lifter lever stopper screw ② so that section A of the height of presser foot is 9 mm or more (standard) when presser lifter lever ① is in the lowest position.<li data-bbox="172 387 938 454">2. Loosen nut ③ of presser lifter lever stopper screw ② and adjust the height with presser lifter lever stopper screw ②.<li data-bbox="172 465 938 499">3. After the adjustment, fix the height adjusting screw with nut ③.<li data-bbox="172 510 938 622">4. In the state that the presser foot is lifted by 9 mm, make the section B, clearance between collar ④ and presser bar bushing ⑤ 0.1 to 0.5 mm.	

(15) Adjusting V072

Standard Adjustment

1) Position of the upper feed roller

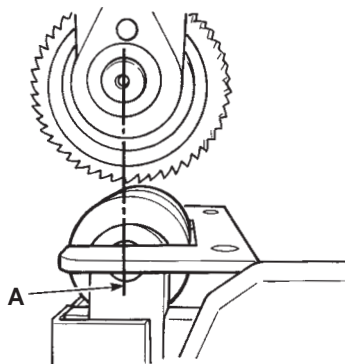
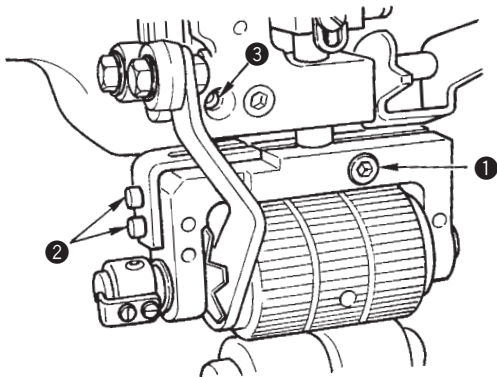

Upper feed roller pressure adjusting screw

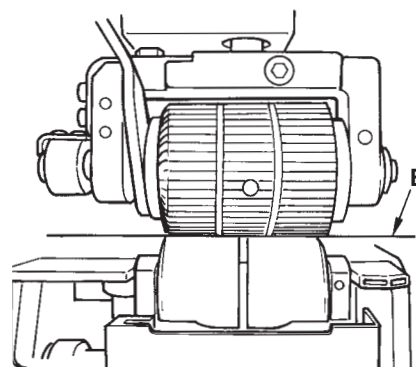
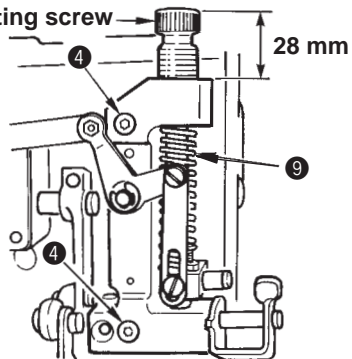

2) Adjusting the height of the lower roller

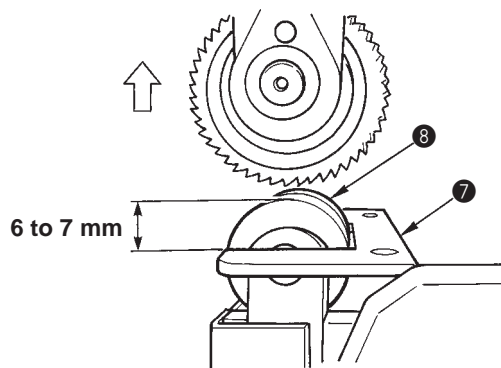
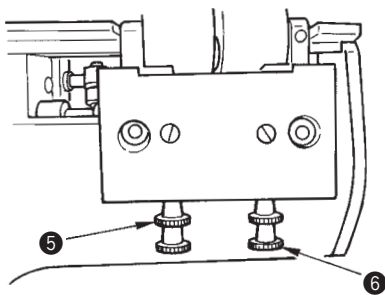

3) Vertical position of the roller

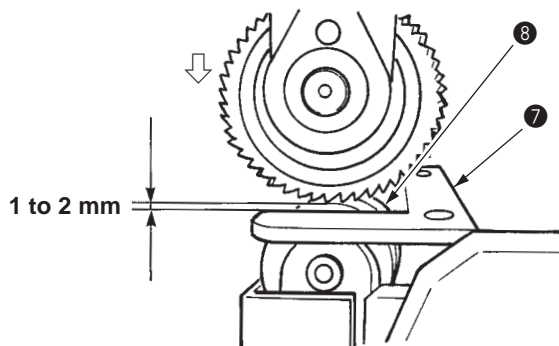
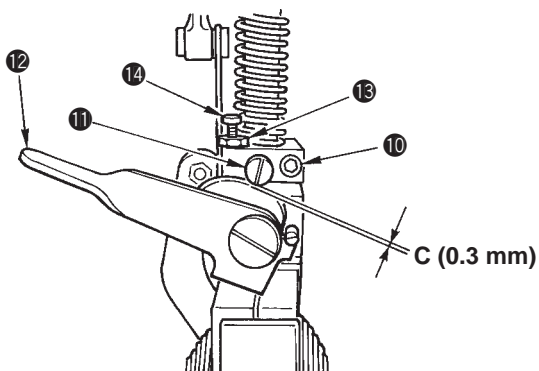

Adjustment Procedures	Results of Improper Adjustment
<p>1) Position of the upper feed roller</p> <ol style="list-style-type: none"> 1. Remove upper feed roller cover, lever cover and upper feed roller pressure adjusting screw. 2. Loosen setscrew ① in the upper feed roller base, setscrew ② in the yoke guide and setscrew ③ in the yoke pin, and adjust so that the gear section of the upper feed roller is parallel to the center core of the lower roller shaft. 3. After determining parallel position A with setscrew ① in the upper feed roller base and setscrew ② in the yoke guide, check that the upper feed roller with roller presser spring ⑨ removed lightly moves up or down. Then tighten setscrew ③ in the yoke pin. (Make sure that the roller lightly moves up or down even after tightening the setscrew.) 4. Loosen two setscrews ④ in the upper feed roller bracket and adjust so that the gear section of the upper feed roller is parallel B to the lateral height of the lower roller. 5. After the adjustment, check that the upper feed roller with roller presser spring ⑨ removed lightly moves up or down. Then tighten setscrews ④ in the upper feed roller bracket. 6. Check that the roller lightly moves, and attach the cover, roller presser spring and pressure adjusting screw. (Height of the pressure adjusting screw is 28 mm.) <p>2) Adjusting the height of the lower roller (State that the upper feed roller is lifted with upper feed roller lifting lever ⑫)</p> <ol style="list-style-type: none"> 1. Loosen lock nut ⑥ of lower roller height adjusting nut ⑤. 2. Adjust the height of lower roller ⑧ to 6 to 7 mm from the top surface of cylinder cover (upper) ⑦ using lower roller height adjusting nut ⑤. (Perform the adjustment of the height to both of left and right sides.) <p>(Caution) The pressure of the left lower roller pressure spring is different from that of the right one. Do not mistake when removing the springs. (The spring on the left side as observed from the sewing machine is a weak one.)</p> <p>3) Vertical position of the roller</p> <ol style="list-style-type: none"> 1. Remove the upper feed roller pressure adjusting screw and lower the upper feed roller. 2. Loosen screw ⑩ in the upper feed roller presser bar bracket and lower the roller to the lowest position. Loosen height adjusting screw lock nut ⑬ and adjust the height with adjusting screw ⑭ so that the clearance between periphery of upper feed roller lever sleeve ⑪ in the upper feed roller presser bar bracket and cam section A of upper feed roller lifting lever ⑫ should be approximately 0.3 mm. After the adjustment, fix screw ⑭ with lock nut ⑬. 3. Press down the upper feed roller presser bar and tighten setscrew ⑩ in the upper feed roller presser bar bracket at the position of the part where the lower roller ⑧ protrudes from the top surface of cylinder cover (upper) ⑦ is 1 to 2 mm when the upper feed roller presses the lower roller ⑧. Make sure that the upper feed roller presser bar bracket is parallel to the lower roller ⑧ when tightening the setscrew. <p>(Caution) If the upper feed roller presser bar bracket is bent at the time of installation, the upper feed roller may not go up smoothly when lifting it with the upper feed roller lifting lever ⑫.</p>	

(15) Adjusting V072

Standard Adjustment

- Adjusting clearances **A** and **B** portions

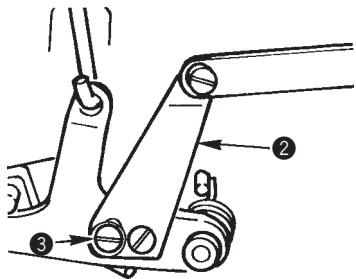
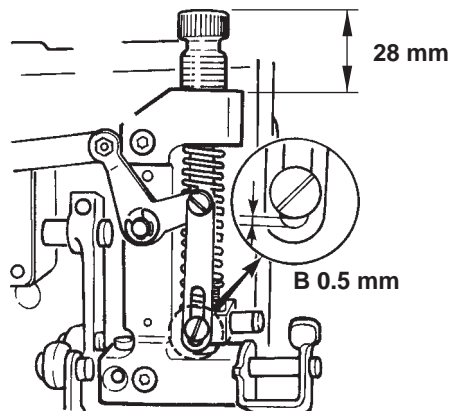
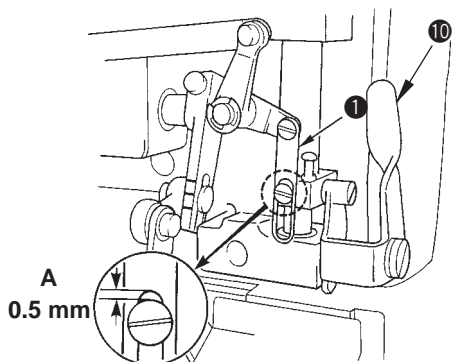

4) Adjusting feed amount of upper feed roller

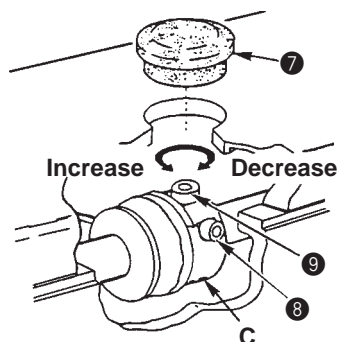
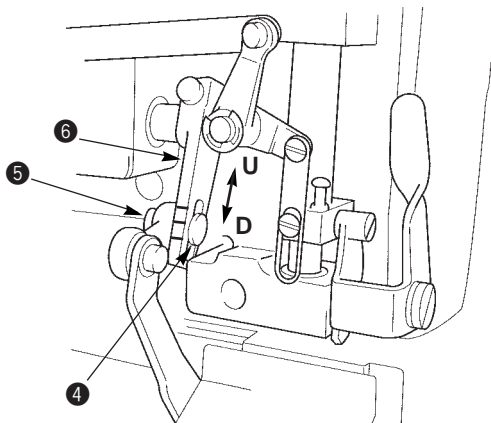

Adjustment Procedures	Results of Improper Adjustment
<p><When up / down of the upper feed roller is not synchronized with up / down of the presser foot></p> <ol style="list-style-type: none"> 4. Attach the pressure adjusting screw to the upper feed roller and tighten the screw up to the height of 28 mm. 5. Lift the upper feed roller with upper feed roller lifting lever ⑩ and adjust the slot position of upper feed roller lifting connecting plate ①. Loosen screw ③ in upper feed roller lifter (right) ② and adjust so that the clearance of section A between the top surface of the slot and the hinge screw should be 0.5 mm. After the adjustment, tighten screw ③. (When performing this adjustment, the upper feed roller does not go up synchronously with the presser foot even when the presser foot is lifted.) <p><When up / down of the upper feed roller is synchronized with up / down of the presser foot></p> <ol style="list-style-type: none"> 6. When lifting the upper feed roller synchronously with the presser foot, perform the adjustment in the state that the upper feed roller is lowered. 7. Loosen screw ③ in upper feed roller lifter (right) ② and adjust so that the clearance of section B between the bottom surface of the slot of upper feed roller lifting connecting plate ① and the hinge screw should be 0.5 mm. After the adjustment, tighten the screw ③. <p>4) Adjusting the feed amount of the upper feed roller Adjust the momentum of the upper feed roller in accordance with the materials used and sewing conditions.</p> <ol style="list-style-type: none"> 1. Remove the upper feed roller cover. 2. Loosen nut ⑤ stopping upper feed roller lever pin ④ and set upper feed roller lever pin ④ so that it is positioned in the center position of the slot of upper feed roller lever ⑥ as the standard. After setting, tighten nut ⑤. 3. If the aforementioned adjustment is insufficient, adjust the position of upper feed roller lever pin ④. <ul style="list-style-type: none"> ○ Direction U Feed amount is decreased. ○ Direction D Feed amount is increased. 4. After the adjustment, replace the upper feed roller cover. 5. When the feed amount is insufficient even after adjusting upper feed roller lever pin ④, remove rubber cap ⑦ on the top cover. (Place the position of the upper feed roller lever pin ④ to the center position of the engraved marker dot before starting the adjustment. Then perform the adjustment.) 6. Turn the handwheel until setscrew ⑧ in the feed adjusting eccentric comes to right above, and loosen setscrew ⑧ using the hexagonal wrench key. 7. Turn the handwheel until adjusting screw ⑨ comes to right above to adjust the screw position. 8. Insert the hexagonal wrench key into adjusting screw ⑨ to adjust the feed amount. <ul style="list-style-type: none"> ○ When the feed amount of the upper feed roller is desired to be increased : Turn adjusting screw ⑨ counterclockwise. ○ When the feed amount of the upper feed roller is desired to be decreased : Turn adjusting screw ⑨ clockwise. 9. When adjusting of the feed amount is completed, securely fix with setscrew ⑧. <p>(Caution)</p> <ol style="list-style-type: none"> 1. Avoid to excessively change the feed amount. The feed amount exceeds the range of the slot of the upper feed roller lever and re-adjustment is necessary. 2. Do not loosen two setscrews in the cam at section C except ⑧ and ⑨. Roler timing will change. 	<ul style="list-style-type: none"> ○ This adjustment is used in case of the continuous sewing. ○ When the feed amount of the upper feed roller in terms of the needle feed is not proper, needle breakage or stitch skipping will be caused.

(15) Adjusting V072

Standard Adjustment

5) Adjusting pressure of the clutch tension spring

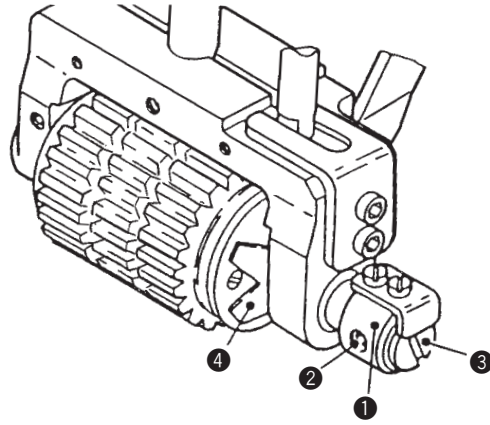

Adjustment Procedures	Results of Improper Adjustment
<p>5) Adjusting the pressure of the clutch tension spring</p> <ol style="list-style-type: none"> 1. Loosen two setscrews ② in collar ① and temporarily tighten them. 2. Turn adjusting screw ③ to adjust the pressure of clutch tension spring ④. When adjusting screw ③ is turned clockwise, the pressure is increased. When adjusting screw ③ is turned counterclockwise, the pressure is decreased. 3. Adjust the pressure of clutch tension spring ④ to such an extent that the screw is turned by pressing the spring with a finger. 4. After the adjustment, tighten two setscrews ② in collar ①. 	<ul style="list-style-type: none"> ○ When the roller is replaced with the iron one, reduce the sewing speed to 3.500 rpm.

4. LUBRICATION

(1) Replacing the lubricating oil

Standard Adjustment

1) Replacing time of the lubricating oil

- In case of a new sewing machine, replace the lubricating oil after the machine has been used for about 250 hours. Then replace the lubricating oil every 6 months.

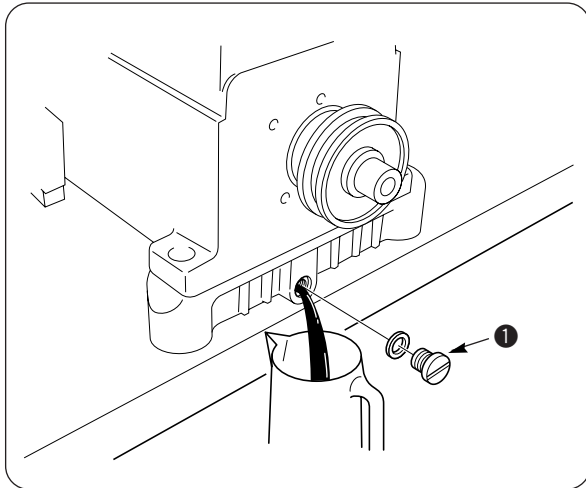

2) Replacing procedure of the lubricating oil

1. Remove the belt cover. (See Instruction Manual.)
2. Remove V belt from the motor pulley. (See Instruction Manual.)
3. Remove the machine head from the sewing machine table. (See Instruction Manual.)
4. Set a container to receive the lubricating oil under drain screw ①.
5. Remove drain screw ①. The lubricating oil is drained.

(Caution) Be careful that oil does not adhere to V belt.

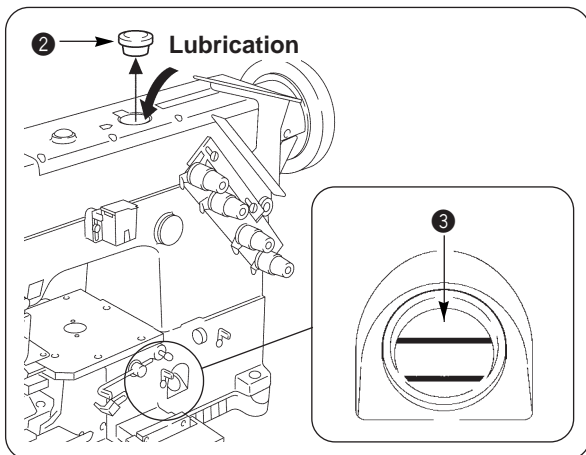

6. After the drain, replace the drain screw ①.
7. Remove rubber cap ② on which "OIL" is indicated.
8. Supply new lubricating oil to the hole from which rubber cap ② has been removed up to the upper red line of oil gauge ③.
 - Oil used : JUKI New Defrix Oil No. 2
(Equivalent to ISO VG32)
 - Oil amount : 900 mℓ
9. Attach rubber cap ② after filling lubricating oil.
10. Set the machine head onto the sewing machine table. (See Instruction Manual.)
11. Fit V belt to the motor pulley and attach the belt cover. (See Instruction Manual.)

(Caution) 1. Be sure to supply lubricating oil to the portion between the two red lines of oil gauge ③.

2. If the oil level is above the upper red line, oil leakage may occur.

3. If the oil level is below the lower red line, machine trouble will be caused.

(1) Replacing the lubricating oil

Standard Adjustment

3) Inspecting and replacing the oil filter

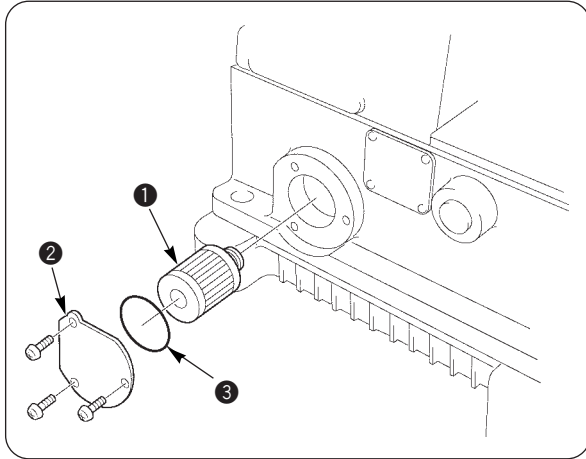

- Normal lubrication cannot be performed if dust collects in oil filter ①. Inspect it every 6 months.

<Inspecting/replacing procedure>

1. Remove oil filter cap ②, and draw out O ring ③ and oil filter ①.
2. When oil filter ① is clogged with dust, replace it with a new one.

(Caution) When removing oil filter cap ②, lubricating oil collected in oil filter ① will leak out. So, be careful.

(2) Adjusting the oil amount

Standard Adjustment

- Oil amount in the face plate section (Standard : 4,000 rpm) : Remove the face plate to check the oil amount.
1. Insert a piece of paper inside the machine arm (in the rear of the presser spring), and judge the oil amount from the oil mark adhered to the paper by splashing from the needle bar crank.
 2. Measure the oil amount for five seconds, and the standard of the oil mark is the state as shown in the illustrations below.
- (Adjust the oil amount so that the width of oil mark is within 1 to 3 mm.)

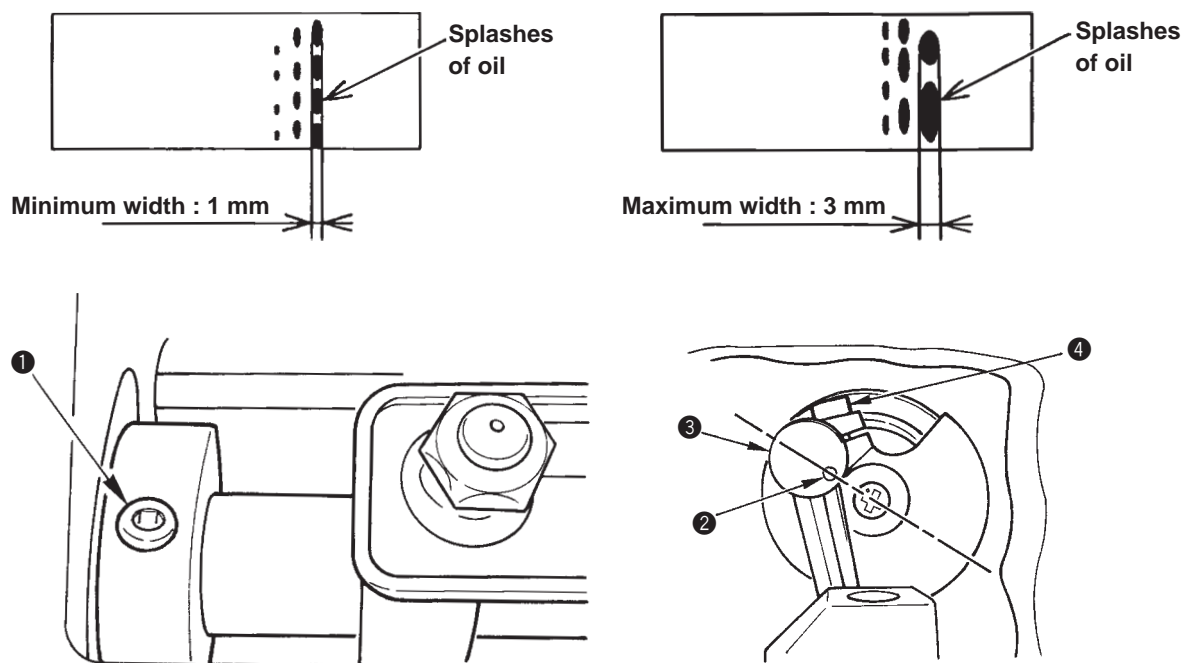

(3) Lubricating route

Standard Adjustment

For the MH-1410, the three stage type trochoid pump is used to forcibly lubricate the inside of the sewing machine and the respective mechanisms, and to simultaneously perform the recovery of oil. Check the state of lubrication and reflux of oil referring to the illustration below.

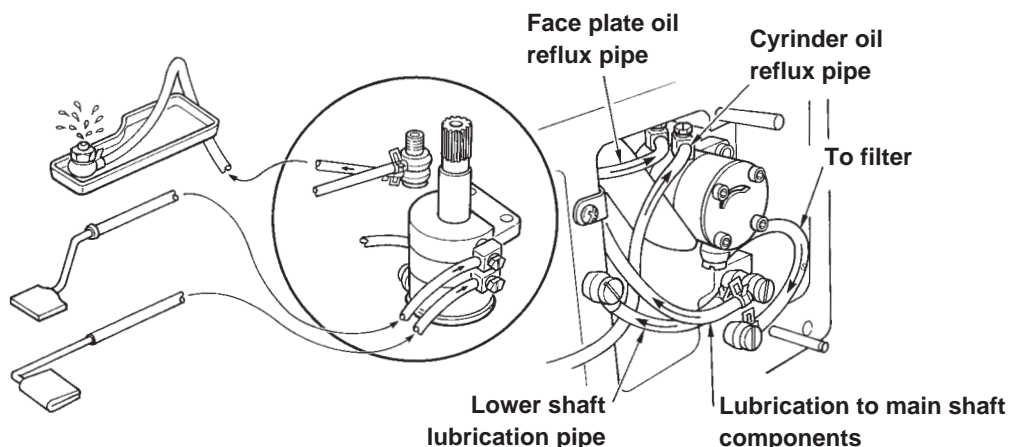

Adjustment Procedures	Results of Improper Adjustment
<p>1. Remove the top cover.</p> <p>2. Adjust screw ❶ (double screw) in the face plate oil amount collar located at the left edge of upper shaft.</p> <p>3. When the screw in the rear is loosened, oil amount in the face plate section is increased and when it is tightened, oil amount in the face plate section is decreased. (The oil amount does not change immediately even when adjusting the oil amount.)</p> <p>4. After the adjustment, check the oil amount in the face plate section and tighten screw ❶.</p> <p>(Caution) When needle bar rod pin ❸ is removed, do not mistake the attaching direction of the pin since there is a direction to attach the pin.</p> <ul style="list-style-type: none"> ○ Attaching direction : There is a marking ❷ on the flat section of needle bar rod pin ❸. Fix the needle bar rod pin with setscrews ❹ in the needle bar rod pin at the position where marking ❷ faces the center of upper shaft. In addition, when tightening, equally tighten two setscrews ❹. 	<ul style="list-style-type: none"> ○ When the oil amount in the face plate section is excessively decreased, machine seizure will be caused. ○ When the marking cannot be adjusted, machine seizure will be caused. ○ When setscrews ❹ in the needle bar rod pin are not equally tightened, the setscrews may be loosened.

Adjustment Procedures	Results of Improper Adjustment

5. SPECIAL SETTING OF SC-380

(1) Adjusting SC-380

Standard Adjustment

○ Changing the setting of SC-380

1. To use for MH-1410, refer to "How to select the sewing machine head" in the Instruction Manual for SC-380, and change the function to AXM1 (function name) " **AXM1** " (7 segment display) MH-481, 482 (sewing machine model) in the program mode [2] (chainstitch sewing machine head).
2. Change the max. sewing speed to less than 5,000 rpm since the max. sewing speed of MH-481, 482 (sewing machine model) changed in the program mode [2] is 5,500 rpm.
In case of with cloth puller (V072), change the max. sewing speed to less than 4,000 rpm.
3. To change the max. sewing speed, refer to Engineer's Manual and Instruction Manual for SC-380, and change the speed with the program mode [P].

(Caution) When the sewing machine is used at max. sewing speed of 5,500 rpm without change, machine trouble will be caused.

○ Special setting (In case brake noise occurs when the sewing machine stops.)

1. It is effective to change GAIN setting [GA.] since the belt for MH-1410 is longer than that for the normal sewing machine. (A mode)
2. Change the brake time setting when the sewing machine stops. (A mode) [BKT.]
* In case the situation is not improved, return the setting to the original one.
3. Change the effective of operation GAIN for the big inertia sewing machine to [HWG.] (K mode)

○ Changing the thread trimming signal S2 prohibition

Phenomenon

1. When performing depressing and heeling the pedal repeatedly, lock of the thread trimming signal works and there is a case where motor may not rotate even when the pedal is depressed.

Changing the setting

1. Change [S2L] the thread trimming signal S2 prohibition to ON with the P mode.
(Set value at the time of delivery is OF.)
2. Thread trimming operation and presser lifting operation after thread trimming by heeling or the external thread trimming signal S2 are prohibited.

Adjustment Procedures	Results of Improper Adjustment
<p>Adjusting procedure of the special setting</p> <ol style="list-style-type: none"> 1. GAIN setting A mode : [GA. L] [GA. LL] (How to enter A mode : [] + [A]) 2. Brake time setting A mode : [BKT. 14] [BKT. 5] 3. Effective of operation GAIN K mode : [HWG. OFF] [HWG. ON] (How to enter K mode : [] + [] + [A] + [C]) * K mode is the hidden mode. 	

6. TROUBLES IN SEWING AND CORRECTIVE MEASURES

Troubles	Causes (Items to be checked)	Corrective measures	See Inst. Manual
Stitch skipping	<p>Check whether threading is wrong.</p> <p>Check whether needle is bent or needle tip is blunt.</p> <p>Check whether thread tension is too high.</p> <p>Check whether needle-to-looper or to-spreader timing, or the clearance is proper.</p> <p>Check whether needle is too thin for thread.</p> <p>Check whether drawing amount of needle thread is excessive.</p> <p>Check whether drawing amount of looper thread is excessive.</p> <p>Needle attaching is improper. (Direction, insufficient insertion)</p>	<p>Properly pass the thread.</p> <p>Replace the needle.</p> <p>Decrease the thread tension.</p> <p>Adjust needle-to-looper, or -to-spreader timing, or the clearance between needle and looper, or between needle and spreader to a proper value.</p> <p>Replace the needle to a proper one. Or, replace the thread to a proper one.</p> <p>Adjust the needle thread take-up to a proper position.</p> <p>Adjust the looper thread take-up to a proper position.</p> <p>Properly attach the needle.</p>	<p>P13</p> <p>P12</p> <p>P20 to 23</p> <p>P12</p> <p>P19</p> <p>P26</p> <p>P12</p>
Thread breakage	<p>Check whether thread is entangled in thread eyelet, etc.</p> <p>Check whether threading is wrong.</p> <p>Check whether thread tension is too high.</p> <p>Check whether thread is too thick for needle.</p> <p>Check whether quality of thread is not good.</p> <p>Check whether thread is cut from heat.</p> <p>Check whether there are scratches on thread eyelet, looper, thread take-up, etc.</p>	<p>Remove the thread entangled.</p> <p>Properly pass the thread.</p> <p>Decrease the thread tension.</p> <p>Replace the needle to a proper one, or replace the thread to a proper one.</p> <p>Use a good quality thread.</p> <p>Use the silicon oil lubricating unit.</p> <p>Remove the scratch, or replace it with a new one.</p>	<p>P13</p> <p>P13</p> <p>P12</p> <p>P17</p>
Chain-off thread does not come out well.	<p>When stitch length is changed, check whether needle-to-looper, or to-spreader timing is proper.</p> <p>Check whether needle thread tension is too high.</p>	<p>Adjust needle-to-looper, or -to-spreader timing, or the clearance between needle and looper, or between needle and spreader to a proper value.</p> <p>Decrease the needle thread tension.</p>	P20 to 25
Needle breakage	<p>Check whether needle comes in contact with looper.</p> <p>Check whether needle comes in contact with the needle hole in the feed dog.</p> <p>Check whether needle comes in contact with presser foot.</p>	<p>Adjust the clearance between needle and looper or needle guard to a proper value.</p> <p>Adjust the longitudinal position of the needle.</p> <p>Adjust the position of the presser foot.</p>	<p>P21 to 22</p> <p>P12</p> <p>P25</p>
Loose stitches	<p>Check whether threading is wrong.</p> <p>Check whether balance between needle thread and looper thread is proper.</p>	<p>Properly pass the thread.</p> <p>Re-adjust the balance of thread tension.</p>	<p>P13</p> <p>P26</p>
Irregular stitches	<p>Check whether threading is wrong.</p> <p>Check whether balance between needle thread and looper thread is proper.</p>	<p>Properly pass the thread.</p> <p>Re-adjust the balance of thread tension.</p>	<p>P13</p> <p>P26</p>
Lubricating oil does not come out from nozzle.	<p>Check whether amount of lubricating oil is below lower line of oil gauge.</p> <p>Check whether oil filter is clogged with dust.</p>	<p>Supply the lubricating oil.</p> <p>Replace the oil filter.</p>	<p>P9</p> <p>P28</p>

7. DRAWING OF THE TABLE

(1) Top installation type

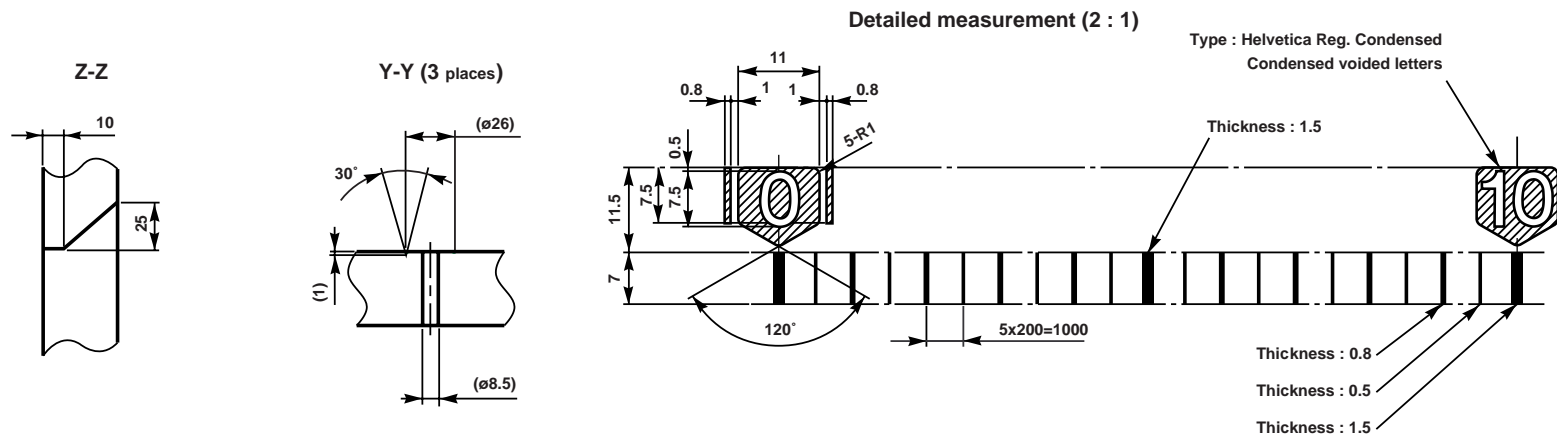
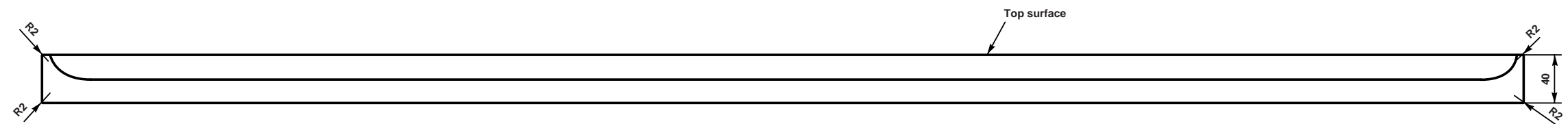
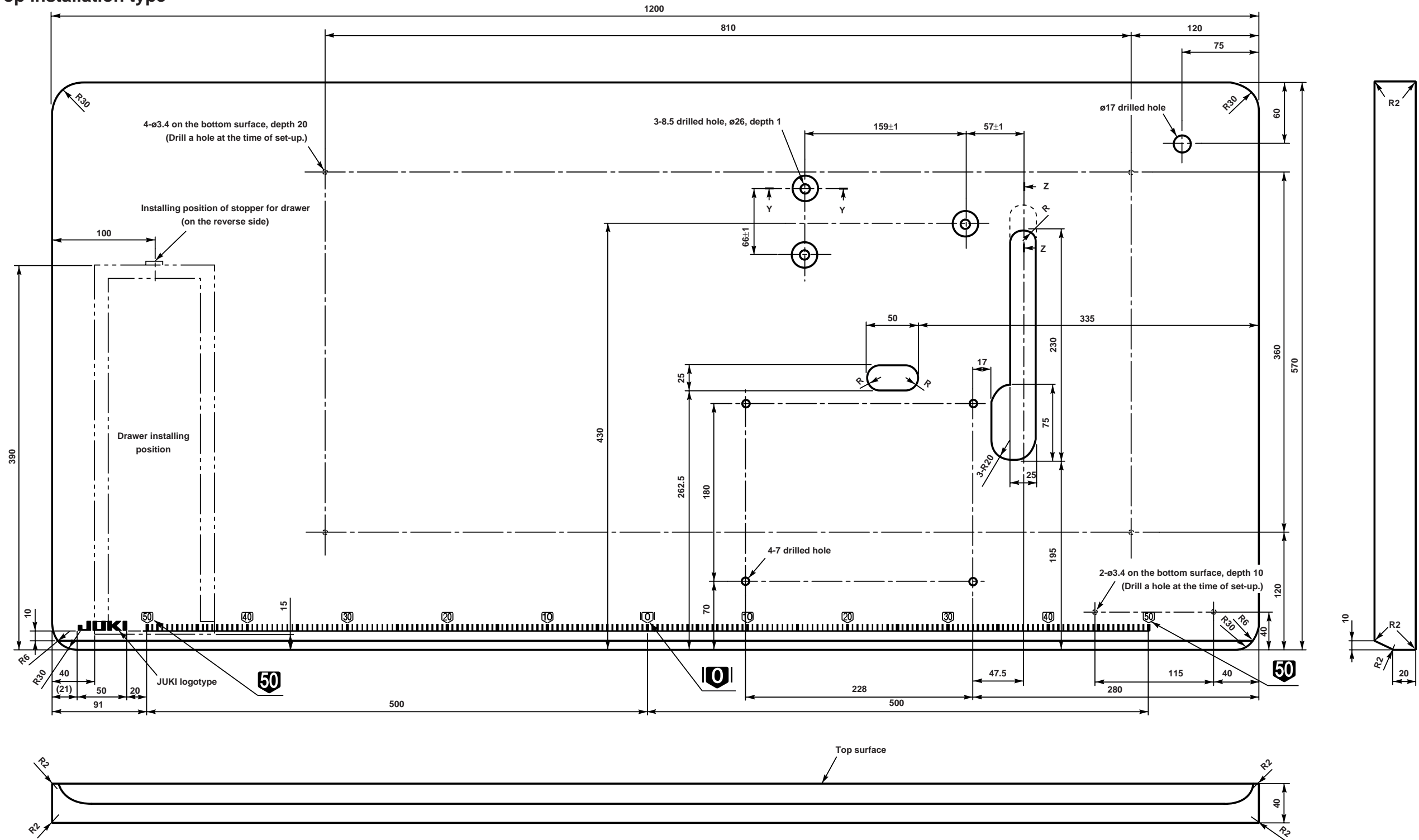

Table Part No. 31138803

(2) Semi-submerged type

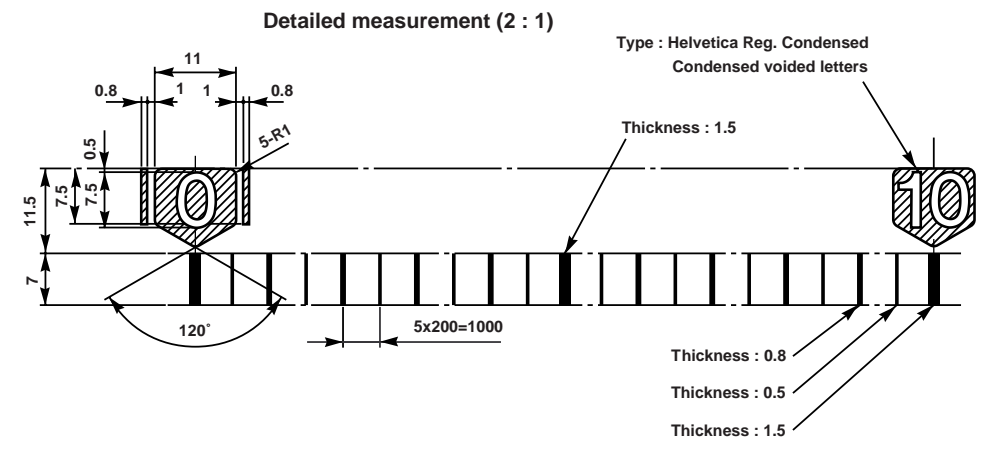
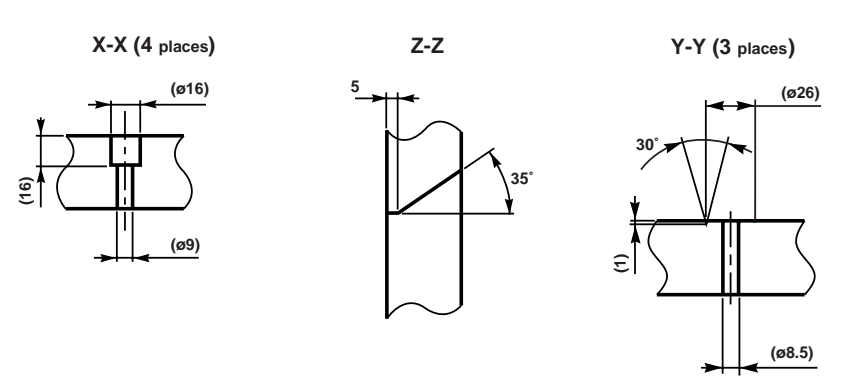
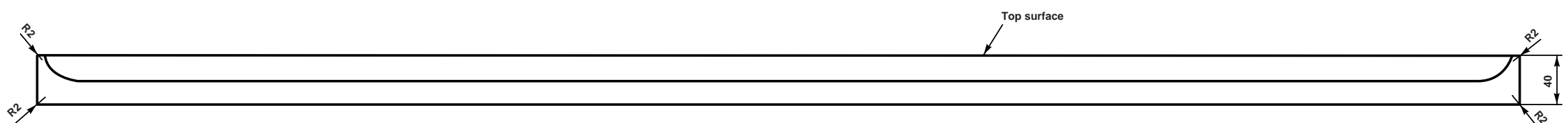
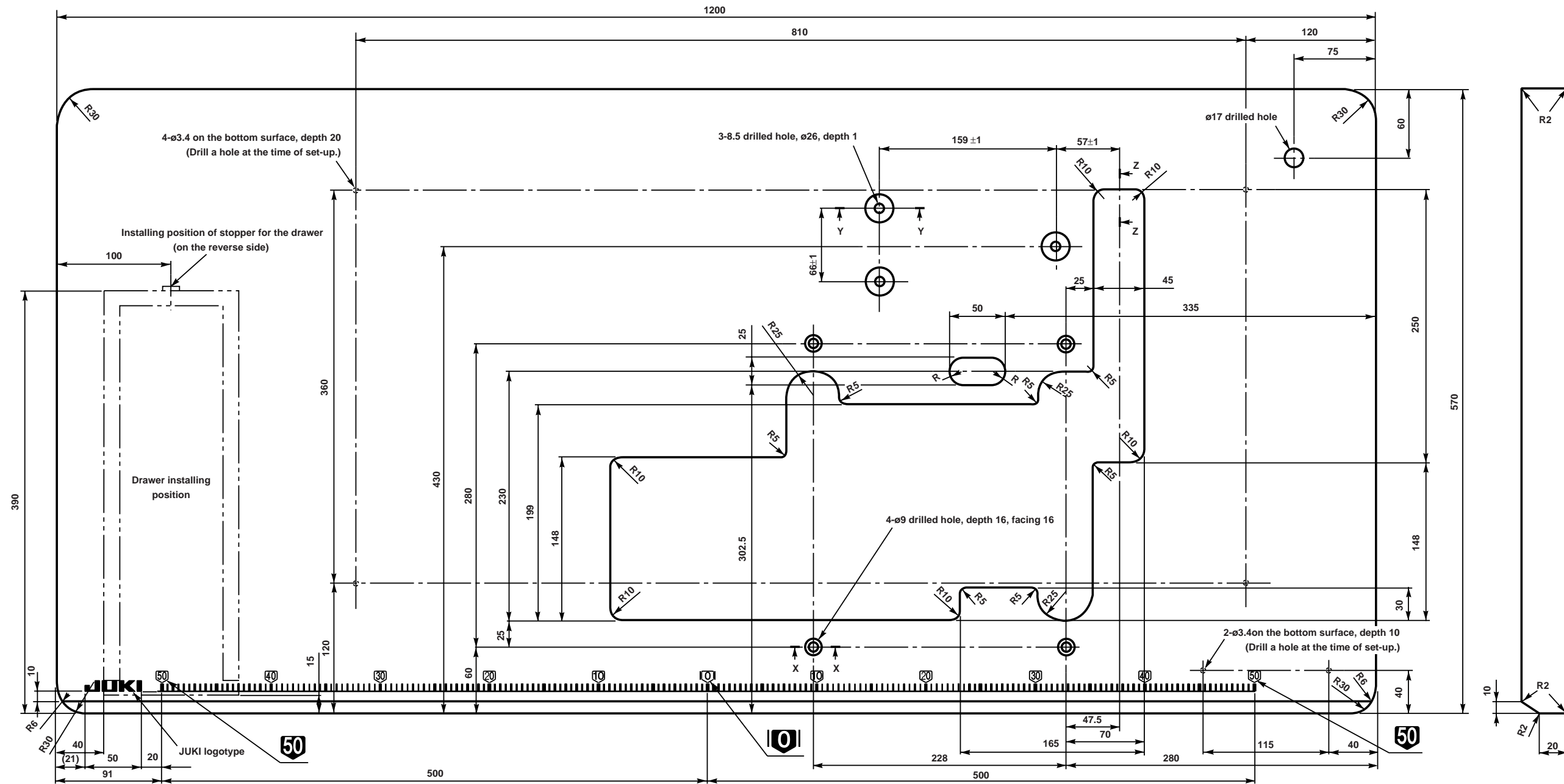

Table Part No. 31141203

JUKI®

**High-speed, 2-Needle / 4-Needle, Needle-feed,
Double Chainstitch Cylinder-bed Machine**

MH-1410

ENGINEER'S MANUAL

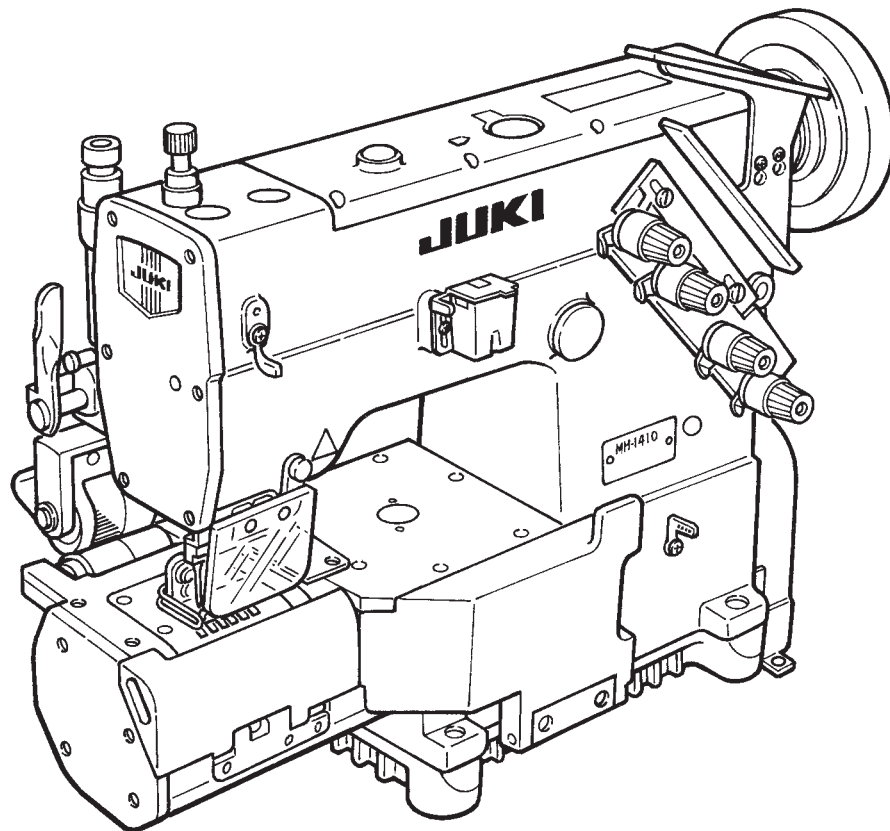

29349305

No.01

PREFACE

This Engineer's Manual is written for the technical personnel who are responsible for the service and maintenance of the machine.

The Instruction Manual for these machines intended for the maintenance personnel and operators at an apparel factory contains operating instructions in detail. And this manual describes "Standard Adjustment", Adjustment Procedures", "Results of Improper Adjustment", and other important information which are not covered in the Instruction Manual.

It is advisable to use the relevant Instruction Manual and Parts List together with this Engineer's Manual when carrying out the maintenance of these machines.

This manual gives the "Standard Adjustment" on the former page under which the most basic adjustment value is described and on the latter page the "Results of Improper Adjustment" under which stitching errors and troubles arising from mechanical failures and "How To Adjust" are described.

CONTENTS

1. SPECIFICATIONS	1
2. CONFIGURATION OF THE MACHINE COMPONENTS	2
3. STANDARD ADJUSTMENT	4
(1) Timing between the upper shaft and the lower shaft	4
(2) Adjusting the height of the needle bar	6
(3) Adjusting the feed dog	8
1) Adjusting the lateral direction of the feed dog	8
2) Adjusting the longitudinal direction of the feed dog	8
3) Adjusting the height of the feed dog	10
4) Adjusting the tilt of the feed dog	10
(4) Adjusting the longitudinal position of the needle feed	12
(5) Adjusting the differential needle feed	14
(6) Adjusting the timing between the needle and the looper	16
(7) Adjusting the attaching angle of the looper	18
(8) Adjusting the clearance between the needle and the needle guard	20
(9) Adjusting the spreader	22
1) Adjusting the lateral position of the spreader	22
2) Adjusting the height of the top end of the spreader	22
3) Adjusting the drawing amount of the spreader	22
(10) Adjusting the spreader eccentric	24
(11) Adjusting the thread tension of looper thread	26
(12) Adjusting the needle thread take-up	26
(13) Adjusting the loop deflector	28
(14) Adjusting the height of the presser foot	30
(15) Adjusting V072	32
1) Position of the upper feed roller	32
2) Adjusting the height of the lower roller	32
3) Vertical position of the roller	32
4) Adjusting feed amount of upper feed roller	34
5) Adjusting pressure of the clutch tension spring	36
4. LUBRICATION	38
(1) Replacing the lubricating oil	38
1) Replacing time of the lubricating oil	38
2) Replacing procedure of the lubricating oil	38
3) Inspecting and replacing the oil filter	39
(2) Adjusting the oil amount	40
(3) Lubricating route	40
5. SPECIAL SETTING OF SC-380	42
(1) Adjusting SC-380	42
6. TROUBLES IN SEWING AND CORRECTIVE MEASURES	44
7. DRAWING OF THE TABLE	45
(1) Top installation type	45
(2) Semi-submerged type	46



JUKI®

JUKI CORPORATION

INTERNATIONAL SALES H.Q.
8-2-1, KOKURYO-CHO,
CHOFU-SHI, TOKYO 182-8655, JAPAN
PHONE : (81)3-3430-4001 to 4005
FAX : (81)3-3430-4909 • 4914 • 4984
TELEX : J22967

Copyright © 2001 JUKI CORPORATION.
All rights reserved throughout the world.



Please do not hesitate to contact our distributors or agents in your area for further information when necessary.
*** The description covered in this engineer's manual is subject to change for improvement of the commodity without notice.**