

JUKI

MF-860N Series

2-Needle, 3-thread bottom covering stitches

ENGINEER'S MANUAL

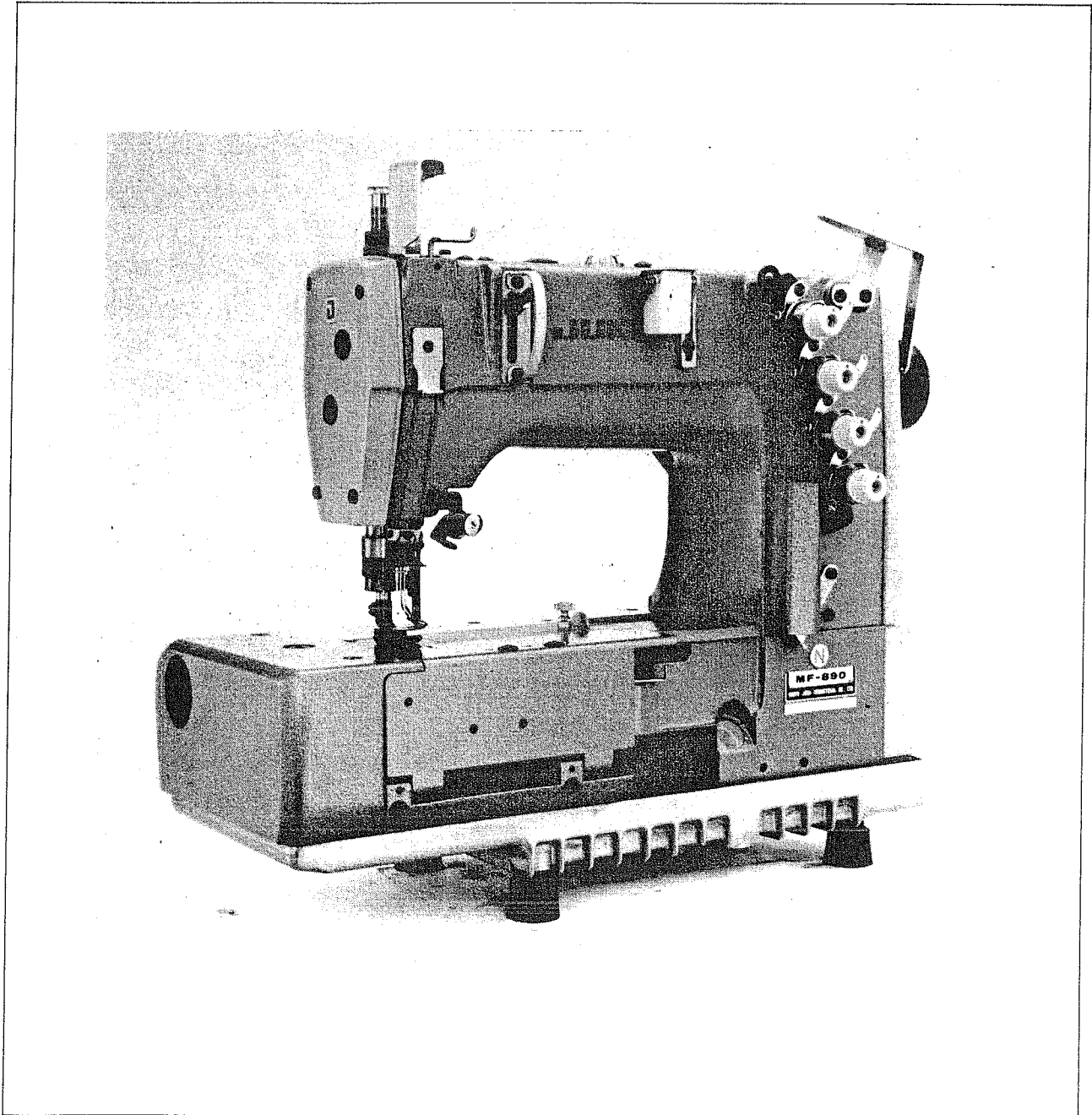

TOKYO JUKI INDUSTRIAL CO., LTD.

CONTENTS

1. MAIN SPECIFICATIONS	1
2. MODEL NUMBERING SYSTEM OF MF SERIES	3
(1) Applications	5
(2) Application, model and gauge	7
3. LUBRICATION PATH	10
(1) Main shaft components	10
(2) Lower shaft components	11
4. SETUP AND ADJUSTMENT OF MAIN COMPONENTS	12
(1) Needle bar components	12
(2) Adjusting the lift of the presser foot	12
(3) Timing belt	13
(4) Auxiliary thread take-up lever	13
(5) Spreader thread pull-off lever	13
(6) Feed rocker shaft and main feed bar	14
(7) Looper rocker	14
(8) Looper driving lever ball arm	15
(9) Looper driving lever	15
(10) Needle guard eccentric cam	15
5. OPERATION	19
(1) Needle	19
(2) Thread	19
(3) How to use the thread guard	19
(4) Thread take-up lever thread guide	19
(5) Needle cooler	20
(6) Front needle guard	20
(7) Looper thread tension disc	20
6. ADJUSTMENT	21
Fundamental Adjustment	21
(1) Amount of looper's retreat	21
(2) Timing of the needles and the looper	21
(3) Height of the needle bar	22
(4) Clearance between the needles and the looper	22
(5) Looper thread cam	24
(6) Spreader	24
(7) Thread guide	25
(8) Auxiliary thread take-up lever	26
(9) Feed dog	26
Principle of Stich Formation	28
7. CORRECTIVE MEASURES AGAINST DEFECTIVE STITCHING	30
(1) Stitch skipping	30
(2) Stitch skipping occurs in the top covering stitches	33
8. CORRECTIVE MEASURES AGAINST SINGLE-THREAD CHAINSTITCHES AND THREAD SLIPPING-OUT	34

1. MAIN SPECIFICATIONS

Following are the main specifications of MF-860N series machines.

(1) Type of stitch

a) 860

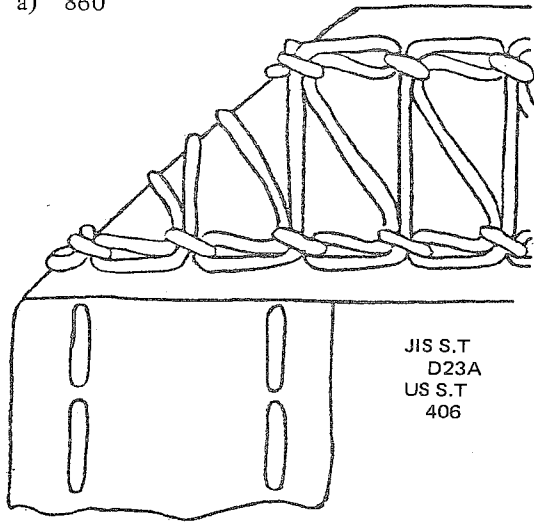

c) 880

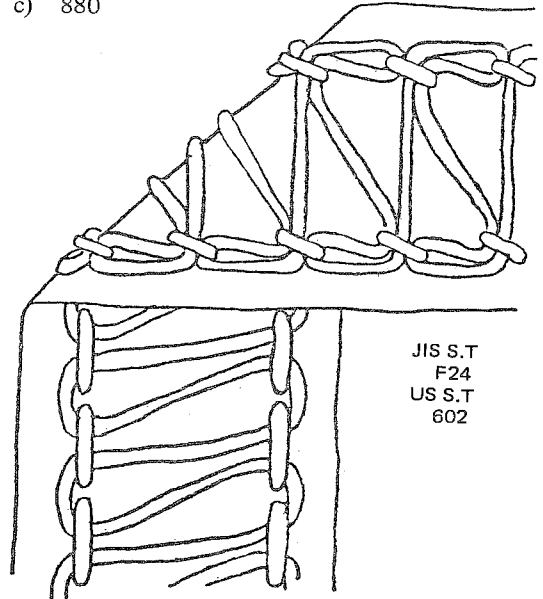

b) 870

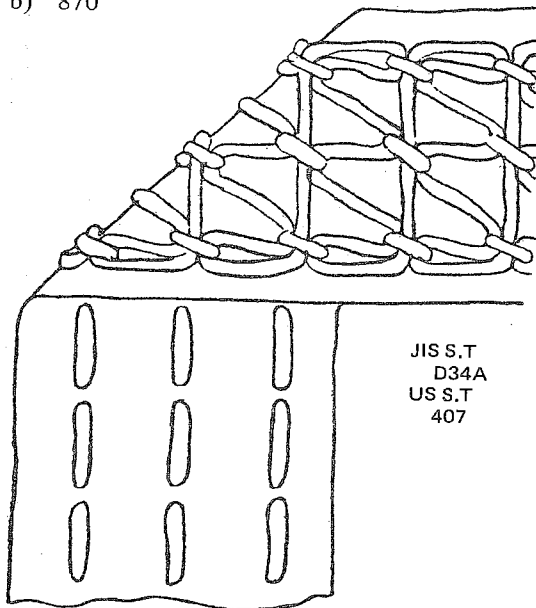

d) 890

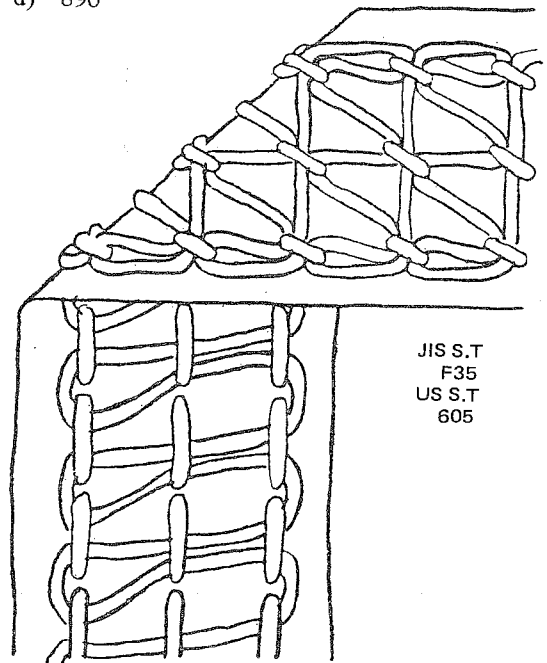

(2) Sewing speed machine pulley and motor

Frequency	Sewing speed (s.p.m.)	Part No. of motor pulley	Effective dia. of motor pulley
50 Hz	6,000	MTK-P0135000	135 mm
	5,500	MTK-P0125000	125
	5,000	MTK-P0115000	115
	4,500	MTK-P1000000	100
	4,000	MTK-P0900000	90
60 Hz	6,000	MTK-P0115000	115 mm
	5,500	MTK-P0105000	105
	5,000	MTK-P0095000	95
	4,500	MTK-P0085000	85
	4,000	MTK-P0075000	75

* Use M-type V belts.

* Use the following motors.

5,000 s.p.m.~6,000 s.p.m. 3/4 HP (550W) 3-phase clutch motor

Less than 5,000 s.p.m. 1/2 HP (400W) 3-phase clutch motor

(3) Lubricating oil: JUKI New Defrix oil No. 2

(4) Lift of presser foot

MF-860, 870 9 mm MF-880, 890 6 mm

2. MODEL NUMBERING SYSTEM OF MF SERIES

Example

1 2 3 4 5 6 7 8 9 10 11 12 13 14 15 16
M F - B 6 0 - G D M - B Z - /

Basic subclass	
With knife	M
Waist band loop	B

Covering stitch		
Without top covering	2-needle	6
	3-needle	7
With top covering	2-needle	8
	3-needle	9

N Needle gauge	
3.2	D
4.0	E
4.8	F
5.6	G
6.4	H
8.0	K

Presser foot	
Double-compensating presser foot	D
Single-compensating presser foot	E
Hinging presser foot	B
Presser foot for side cutter	F
Presser foot for top tape metering device	G
Presser foot for top tape metering device with tape cutter	K
Presser foot for waist band loop	P

Material	
Jersey	M
Knit, bulky, and other heavy-weight materials	K

Tape cutter	
None	Z
AT-11	B

Other devices equipped	
None	Z
Top tape metering device	B

Seam types	
Binder	
Feller	
Guide	
Combination of attachment and device	
Type	
Refer to the separate table (Table of Seam No.)	

Part Numbering System of Gauge R

(1) Throat plate

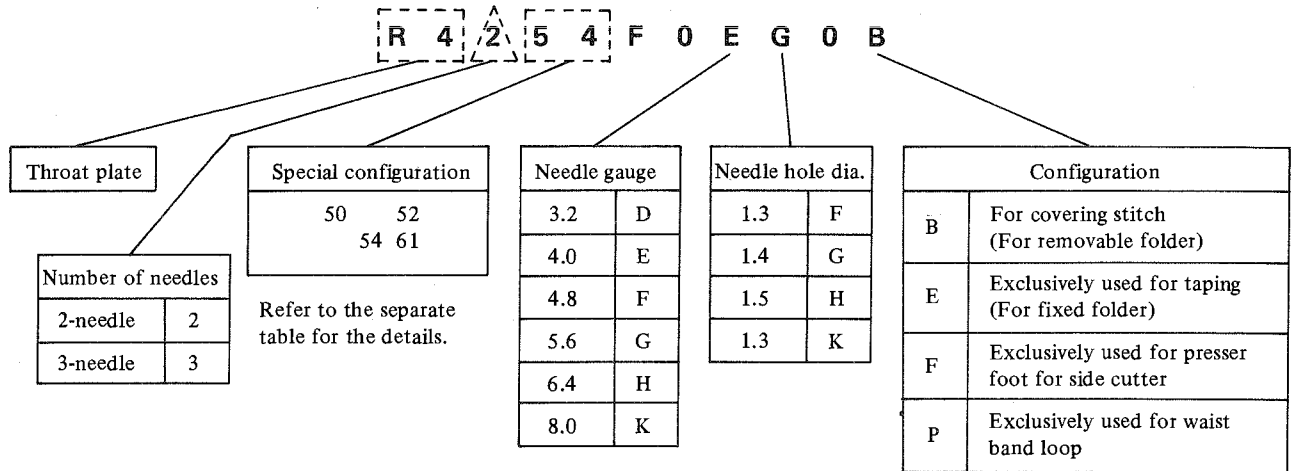

(2) Presser foot

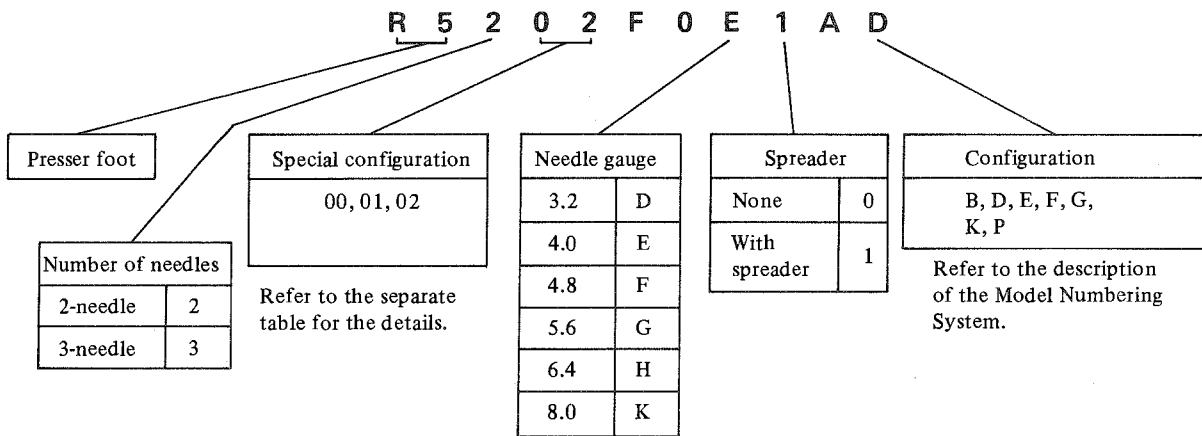

(3) Feed dog

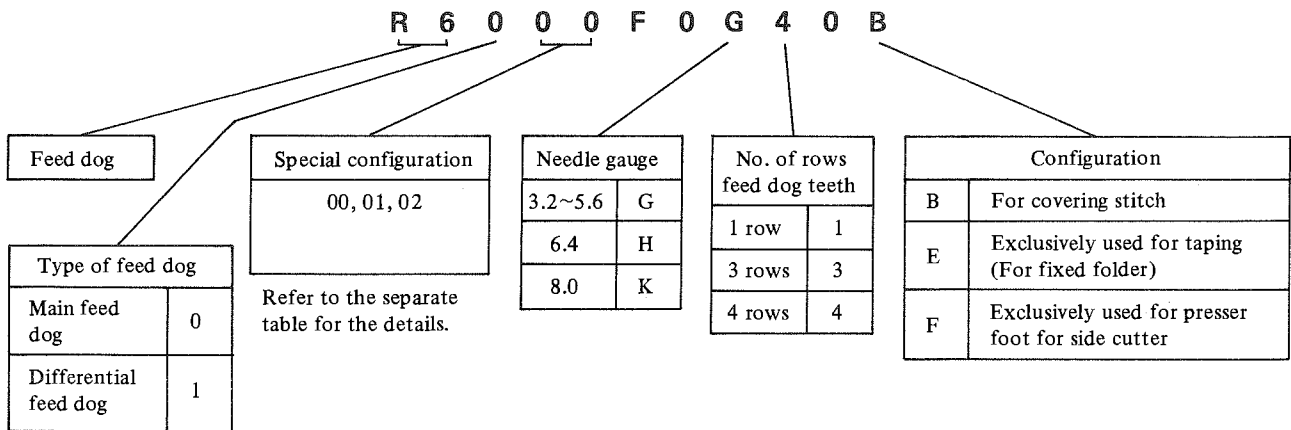

Typical Applications for Each Model of MF-860 Series

(1) Applications

The following illustration shows the typical applications of MF-860 series sewing machines.

(i) Brief

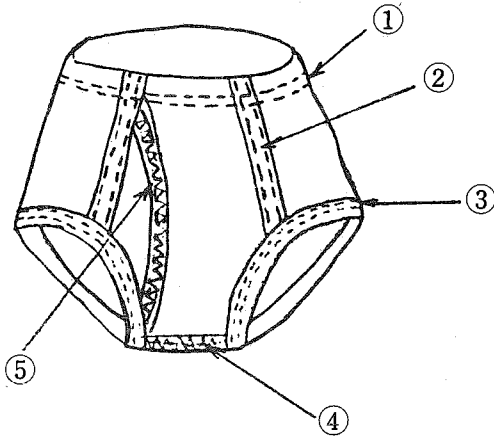

(iv) Ladies' bathing suit

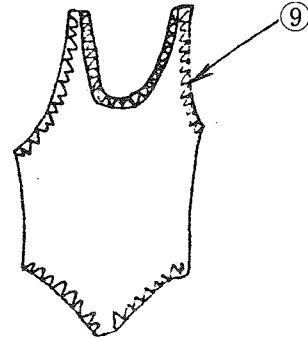

(ii) Running shirt

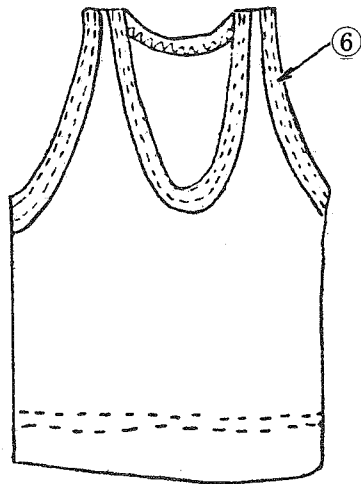

(v) Babies' wear

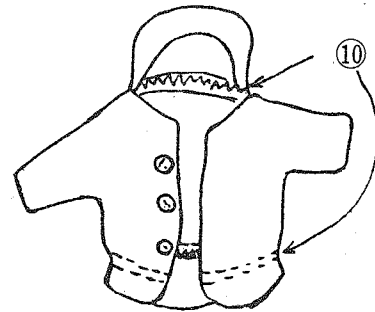

(iii) Men's bathing

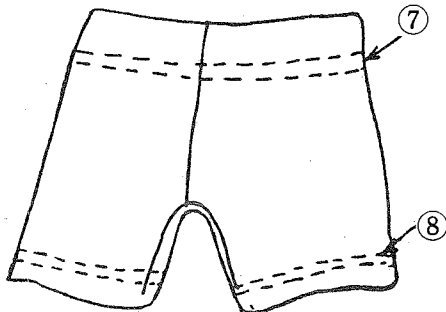

(vi) Cardigan

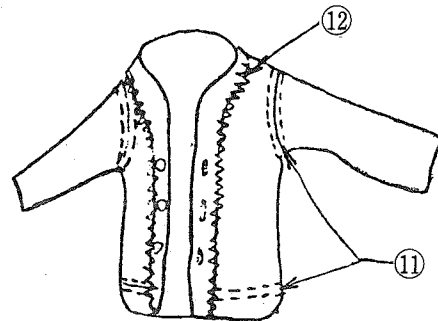

Applications vs. Model

Applications	Needle thread	Looper thread	Needle	Materials	Seam construction	Model	Attachment
1. Brief							
a) Attaching top elastic tape	Cotton #60/3	Cotton #60/3	UY128GAS #65	Ribbed knit		MF-860EDM	K111
b) Tape attaching	"	"	"	"		MF-860GDM	M10G/R009
c) Attaching tape to bottom	"	"	"	"		MF-860EEM	P350K/R006
d) Counterstitching crotch seam	"	"	"	"		MF-890HDM	Q101
e) Attaching front tape	"	"	"	"		MF-880DEM	P350H/R006, P350F/R006
2. Running shirt							
a) Attaching tape to neck line	Cotton #60/3	Cotton #60/3	UY128GAS #65	Ribbed knit		MF-860EEM	P350H/R006
b) Hemming bottom	"	"	"	"		MF-880EDM	K111
3. Men's bathing suit							
a) Attaching top elastic tape	Tetoron #50	Woolly nylon #210	UY128GAS #75	Knit		MF-860GDK	K111
b) Attaching tape to bottom	"	"	"	"		MF-880EEK	P250K/R006
4. Ladies' bathing suit							
a) Topstitching edge	Tetoron #50	Woolly nylon #210	UY128GAS #75	Knit		MF-890GDK	
5. Babies' wear							
a) Coverstitch overedged seam	Tetoron #50	Woolly nylon	UY128GAS #75	Sweater, pile		MF-860GDK	Q108
6. Cardigan							
a) Attaching top-center plait	Tetoron #50	Tetoron #50	UY128GAS #75	Sweater		MF-890GDK	Q107
b) Coverstitch overedged seam	Spun #60	Wool	"	"		MF-890GDK	Q108
7. Brassiere							
a) Attaching elastic tape	Rejilon #60	Woolly nylon	UY128GAS #75	Spandex		MF-860EDR MF-M-860-EKM	ZB/Q102/R008/R014
8. Bib							
a) Attaching tape	Cotton #60/3	Cotton #60/3	UY128GAS #75			MF-830EEK	P350H/R006

(vii) Brassiere

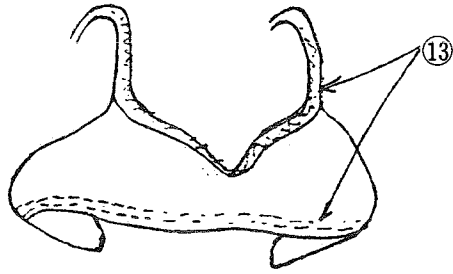

(viii) Bib

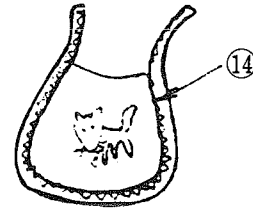

There are many other applications, including sports wear, and T shirts.

(2) Application, Model and gauge

① Table (Examples)

Applications & Process No.	Materials	Model	Throat plate	Feed dog	Presser foot	Remarks (Attachment)
(i) Brief						
No. ①	Ribbed knit	MF-860EDM	R4254F0EG0B	R6000F0G40B R6100F0G40B	R5202F0E1AD	K113
②	"	MF-860GDM	R4254F0GG0B	"	R5302F0G1AD	P350H/R006
③	"	MF-860EEM	R4254F0EG0E	R6000F0G40E R6100F0G10E	R5202F0E1AE	P35
④	"	MF-890HDM	R4354F0HG0B	R6000F0H40B R6100F0H40B	R5302F0H1AD	
⑤	"	MF-880DEM	R4254F0DG0E	R6000F0G40E R6100F0G10E	R5202F0D1AE	
(ii) Running shirt						
⑥	Ribbed knit	MF-860EEM	R4254F0EG0E	R6000F0G40E R6100F0G10E	R5202F0E1AE	
(iii) Men's bathing suit						
⑦	Knit	MF-860GDK	R4254F0GG0B	R6002F0G40B R6102F0G40B	R5302F0G1AD	
⑧	"	MF-880EDK	R4254F0EG0B	"	R5302F0E1AD	
(iv) Ladies' bathing suit						
⑨	Knit	MF-890GDK	R4352F0GG0B	R6002F0G40B R6102F0G40B	R5302F0G1AD	
(v) Babies' wear						
⑩	Sweater, pile	MF-860GDK	R4250F0GG0B	R6002F0G40B R6102F0G40B	R5302F0G1AD	
(vi) Cardigan						
⑪	Sweater	MF-860GDK	R4250F0GG0B	R6002F0G40B R6102F0G40B	R5302F0G1AD	
⑫	"	MF-890GDK	R4352F0GG0B	"	"	
(vii) Brassiere						
⑬	Spandex	MF-870GBK	R4352F0GG0B	R6002F0G40B R6102F0G40B	R5302F0G1AD	
(viii) Bib						
⑭	Ribbed knit	MF-880EEK	R4254F0EG0E	R6002F0G40E R6102F0G10E	R5202F0E1AE	P350K/R006

2 Explanation on the table

(i) General description

- The table shows the present typical applications of MF-860 Series.
- The needle gauges in the table are given just for your reference. The actual needle gauges are determined in accordance with customer's requirements.

(ii) Note

- The presser feet are classified roughly into the following two types.
 - ★ Double-compensating presser foot (D type) – For covering stitch (removable folder)
 - ★ Single-compensating presser foot (E type) – Exclusively used for taping (For fixed folder)
- Feed dog
 - ★ For ribbed knit (M)

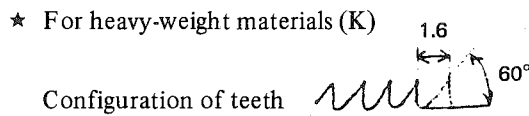
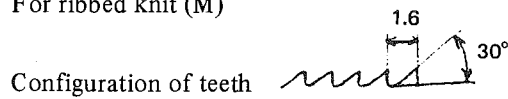

- Throat plate (The circled numerals and alphabets relate with each other.)

D E ★ R4250F0FG0B G H	↔	D E MF ⁸⁷⁰ ₈₉₀ FD K G H	Bulky sweater
★ R4350F0HG0B	↔	MF ⁸⁷⁰ ₈₉₀ HD K	Heavy-weight materials
★ R4352F0GG0B	↔	MF ⁸⁷⁰ ₈₉₀ GD ^K _M	Heavy weight ribbed knit
D E ★ R4254F0FG0B G H	↔	D E MF ⁸⁶⁰ ₈₈₀ FD M G H	Ribbed knit
★ R4354F0HG0B	↔	MF ⁸⁷⁰ ₈₉₀ HDM	Ribbed knit
D E ★ R4254F0FG0E G H	↔	D E MF ⁸⁶⁰ ₈₈₀ FEM G H	Ribbed knit
★ R4352F0GG0E	↔	MF ⁸⁷⁰ ₈₉₀ GEM	Ribbed knit
★ R4354F0HG0E	↔	MF ⁸⁷⁰ ₈₉₀ HEM	Ribbed knit

Changing the Gauge Sets

(Example 1)

MF-880EEM ←→ MF-890GDM
 (Exclusively used for taping) (For covering stitch)

	MF-880EEM	MF-890GDM
1) Needle clamp	B1409880EA0	B1409890GA0
2) Throat plate	R4254F0EG0E	R4352F0GG0B
3) Presser foot	R5202F0E1AE	R5302F0G1AD
4) Main feed dog	R6000F0G40E	R6000F0G40B
5) Differential feed dog	R6100F0G10E	R6100F0G40B
6) Feed dog holder	R162385000E	B162385000A
7) Looper cover	B1117850000	B1116850000B
8) Guide bar (asm)	B50018600C0 (1)	
9) Binder holding base	B5004860000A (1)	
10) Binder holding base washer	B5005860000 (1)	
11) Screw	SS7111410SP (2)	
12) Holder guiding plate	B5006860000 (1)	
13) Screw	SS7120640SP (1)	
14) Screw	SS7110910SP (2)	

(Example 2)

MF-860GDM ←→ MF-860HDM
 (For covering stitch) (For covering stitch)

	MF-860GDM	MF-860HDM
1) Needle clamp	B1409860GA0	B1409860HA0
2) Throat plate	R4254F0GG0B	R4254F0HG0B
3) Main feed dog	R6000F0G40B	R6000F0H40B
4) Differential feed dog	R6100F0G40B	R6100F0H40B
5) Presser foot	R5302F0G1AD	R5302F0H1AD

The above two examples are typical gauge set changes.
 Refer to the gauge set table for other changes of gauge sets.

3. LUBRICATION PATH

(1) Main shaft components

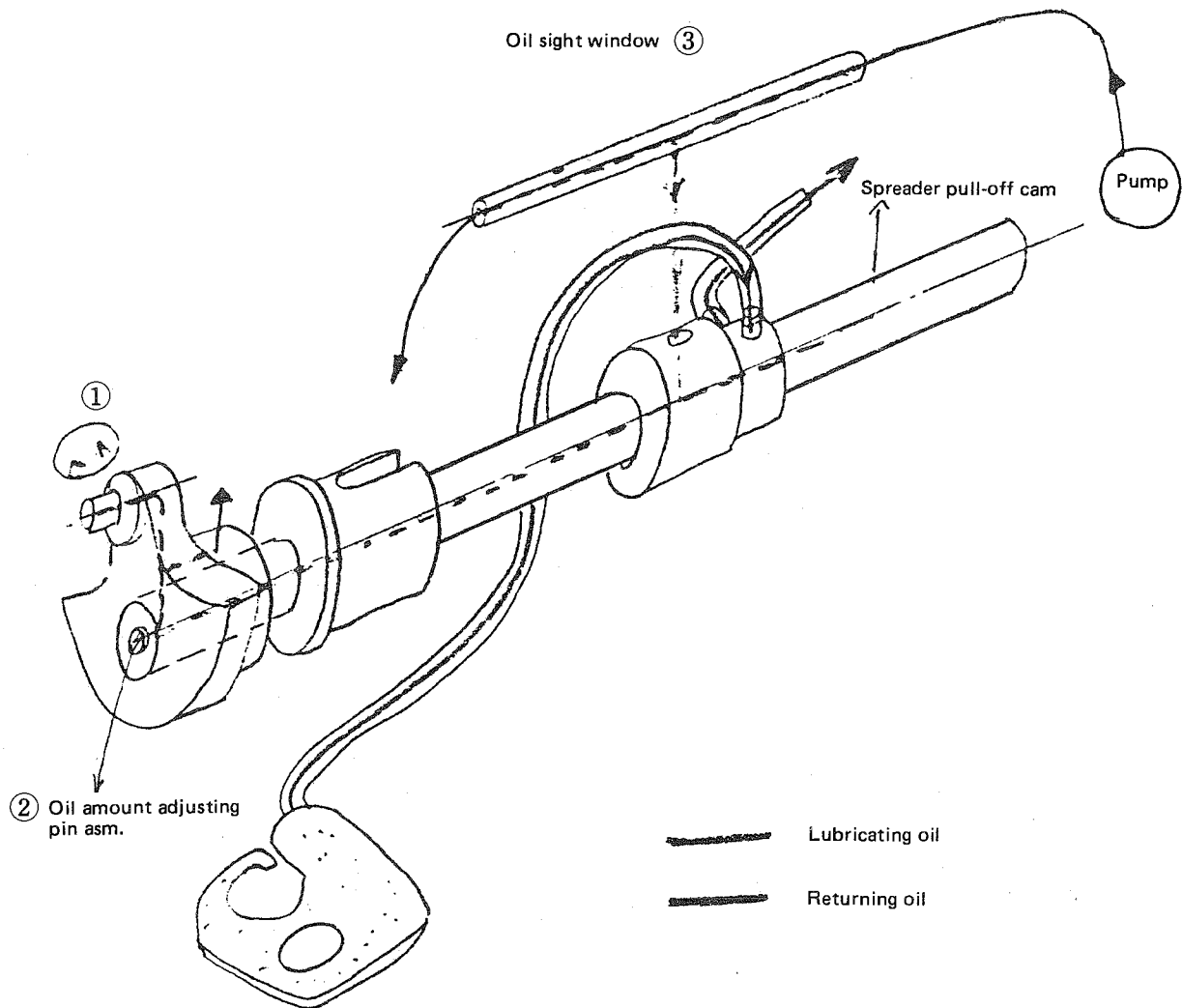

The paths of the lubricating oil and returning oil for the main shaft components are as shown in the above figure.

(i) Refer to the go or not go standard for the proper amount of oil on crank ①.

(ii) Oil return capability – The oil return felt filled with the lubricating oil shall dry and whiten within 5 min. at 6,000 r.p.m.

Note) In this case, the amount of oil on the crank shall be zero.

(iii) The lubricating oil shall appear in the oil sight window at 2,000 s.p.m. or more.

(2) Lower shaft components

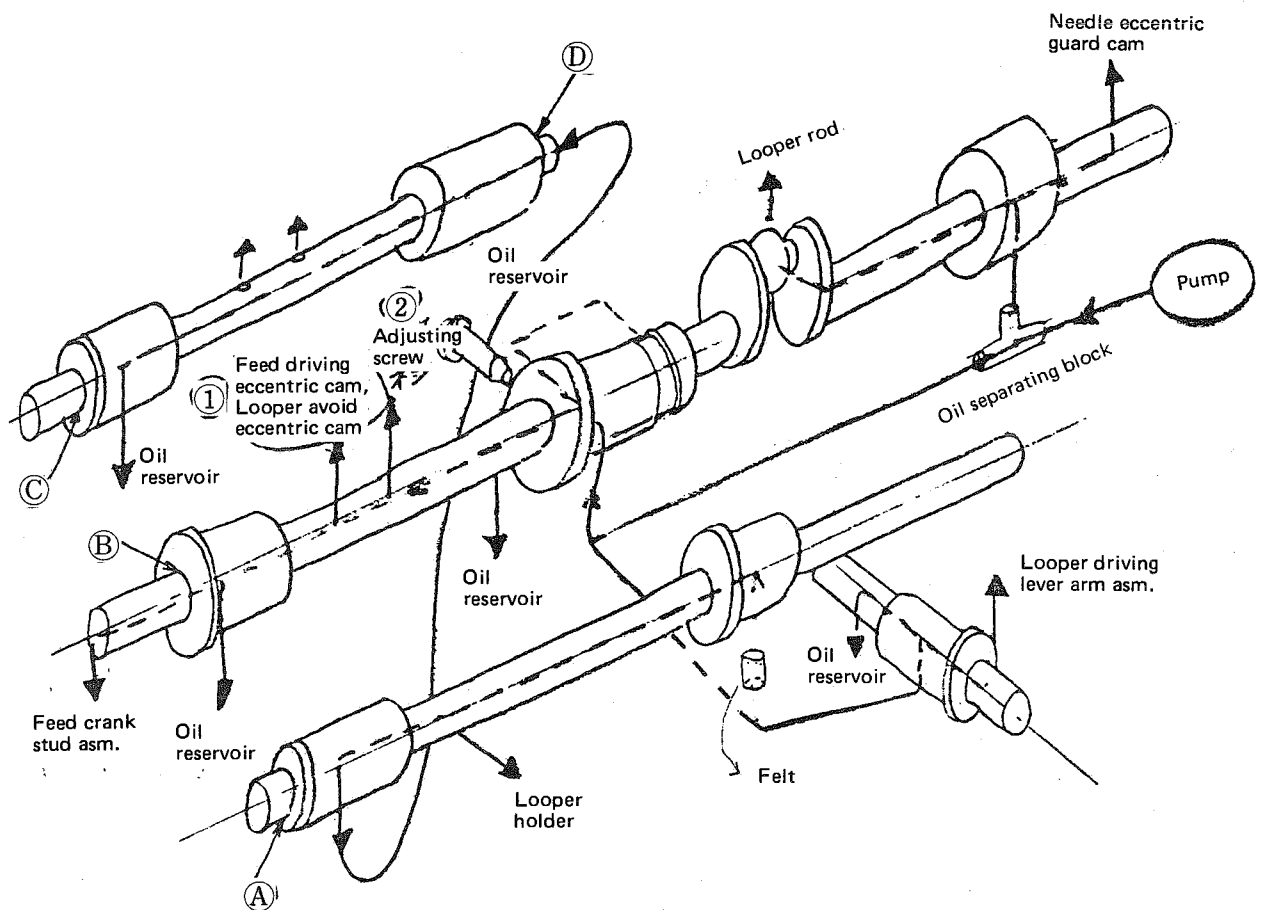

The lubricating path for the lower shaft components is as shown in the above figure.

- (i) Adjust the amount of oil by adjusting screw ② . Refer to the go or not go standard for the proper amount of oil.
- (ii) Measure the amount of oil at ① Feed driving eccentric cam, looper avoid eccentric cam.
- (iii) No oil shall leak from the ends of bushings ④ , ③ , ② , and ① .

4. SETUP AND ADJUSTMENT OF MAIN COMPONENTS

(1) Needle bar components

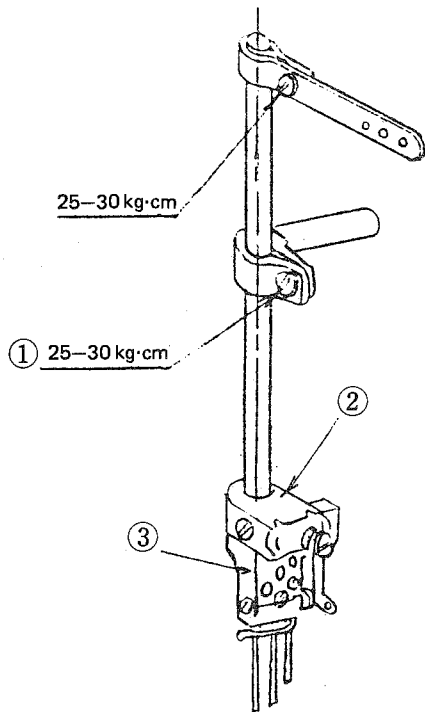

- Loosen screw ① to adjust the height of the needle bar.
 - Install thread guide wire ② in parallel to needle clamp ③.
 - Adjust the needle bar so that the needles pass through the centers of the needle holes in the throat plate.
- (Refer to the figure shown below.)

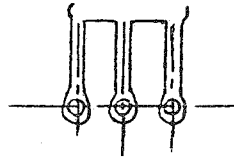

(2) Adjusting the lift of the presser foot

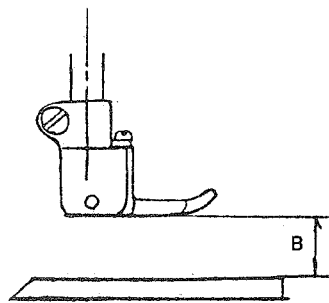

- Lift B of the presser foot:
With top covering (MF-880/890) – 6 mm
Without top covering (MF-860/870) – 9 mm
- To adjust the amount of the lift, loosen nut ③, and adjust distance A by screw ②.

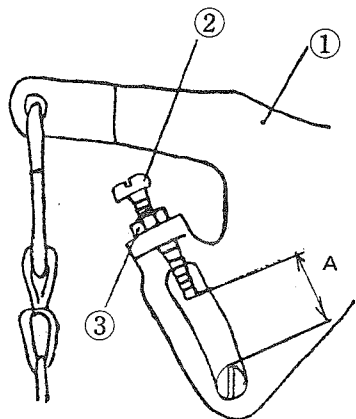

(3) Timing belt

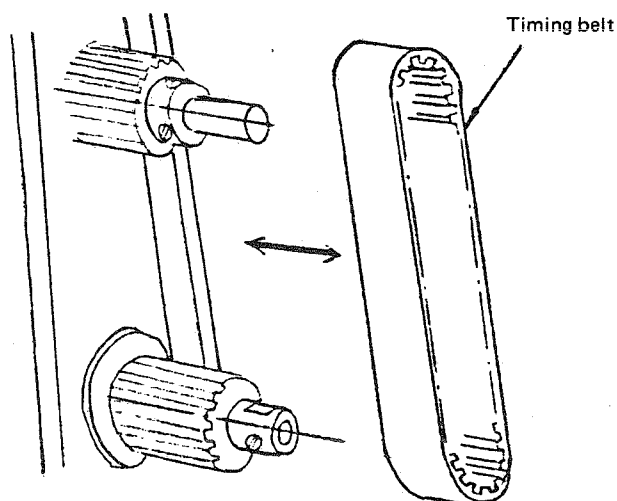

- a) Perform installation or removal of the timing belt as shown in the figure on the left.
- b) When the timing belt is changed, the timing of the needle and the looper may be disturbed. Properly attach the timing belt according to the clause concerned with the stitching adjustment.

(4) Auxiliary thread take-up lever

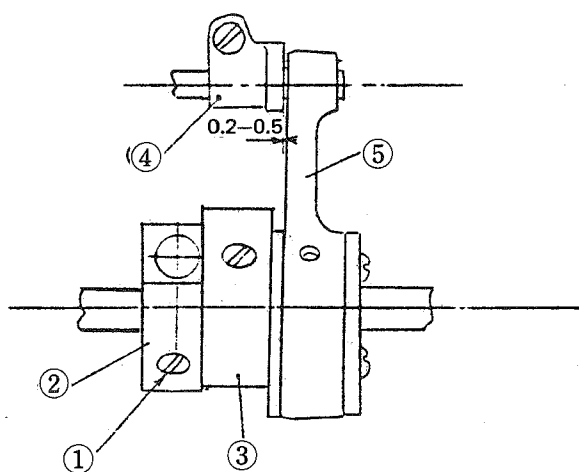

- a) Tighten screw No. 1 ① of timing adjusting thrust ② at the middle of the flat part of the main shaft.
- b) Press auxiliary thread take-up lever cam ③ against thrust ②, and fix the cam. (At this time, be sure to insert the pin into the slit of the adjusting screw of the thrust.)
- c) Provide a clearance of 0.2 to 0.5 mm between link shaft bracket ④ and thread take-up lever link ⑤.

(5) Spreader thread pull-off lever

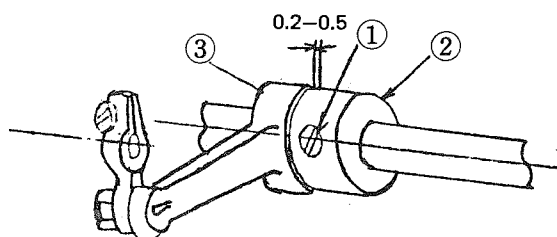

- a) Tighten screw No. 1 ① of spreader pull-off cam ② onto the flat part of the main shaft.
- b) Provide a clearance of 0.2 to 0.5 mm between cam ② and spreader driving link ③.

(6) Feed rocker shaft and main feed bar

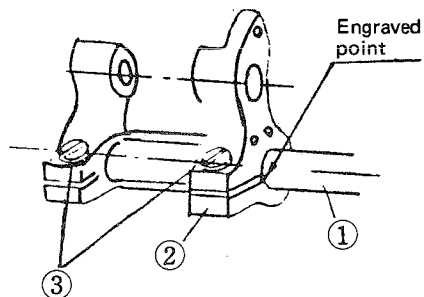

- a) Set feed rocker shaft ① so that the engraved point on feed rocker shaft ① is aligned with the slit of feed rocker ② at the position shown in the figure.
(Caution) If this alignment is not made, oil may leak.
- b) Position of the differential feed dog
 - (i) The position of the throat plate in relation to the needle bar is set by the taper pin.
Set the differential feed dog so that it is positioned in the middle of a slit in the throat plate as shown in the figure on the left.
 - (ii) Adjust the position of the differential feed dog by moving the whole feed bar after loosening screws ③ of feed rocker ② .

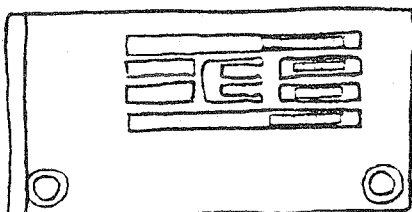

(7) Looper rocker

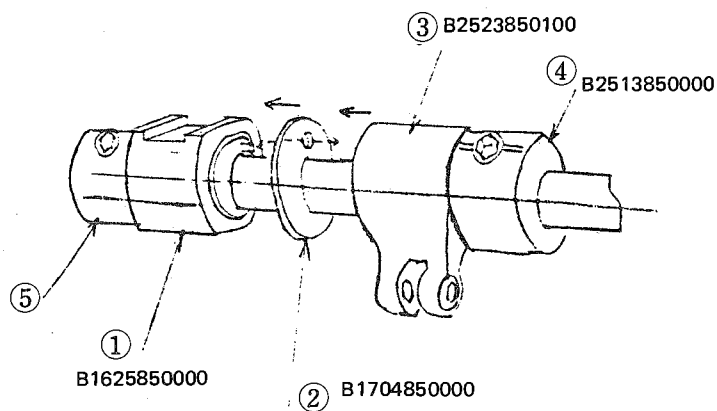

- a) After the differential feed dog has been positioned in the above (6), connect the feed rocker shaft asm. to the feed driving eccentric cam as shown in the figure on the left.
- b) At this time, note that the needle pin fits into the hole in spacer ② .
- c) Push bushing ⑥ fully into looper rocker frame collar ⑦ .
- d) When thrust bushing ⑨ is positioned, looper rocker ⑧ will be consequently positioned.

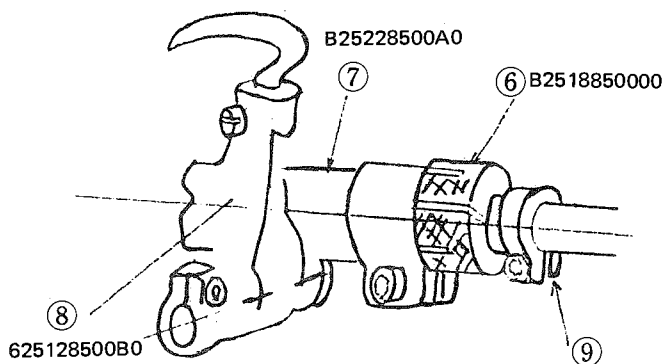

(8) Looper driving lever ball arm

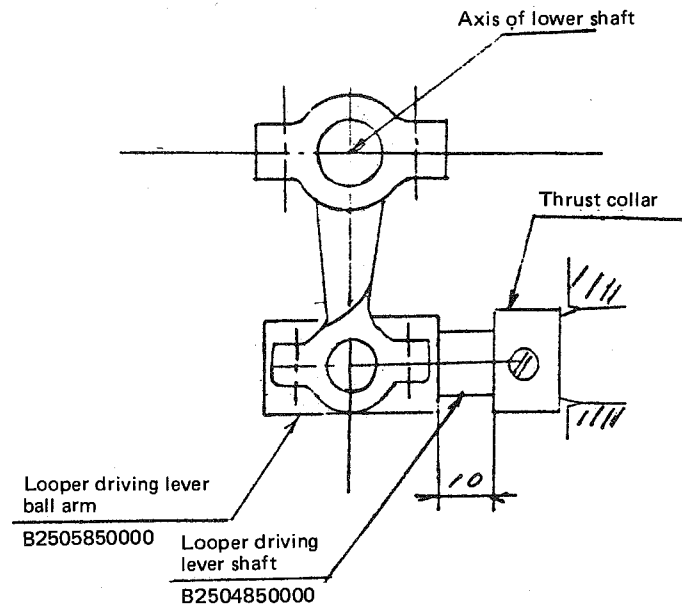

- a) When a 10 mm clearance is provided between the looper driving lever ball arm and the thrust collar, the axis of the lower shaft will be aligned with the center of the looper driving lever ball arm.

(9) Looper driving lever

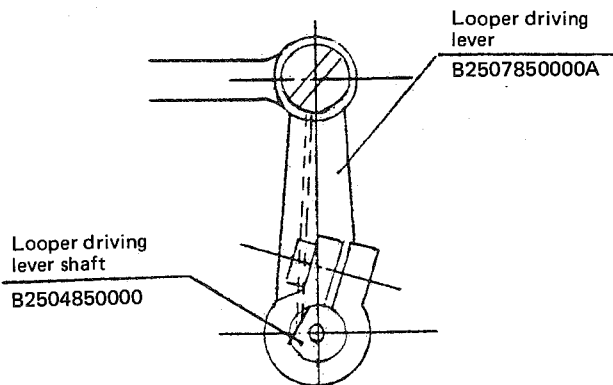

- a) Set the looper driving lever so that it becomes vertical when the looper has retreated farthest.
b) Align the oil hole of the looper driving lever with that of the looper driving lever shaft.

(10) Needle guard eccentric cam

Connect the screw No. 1 of the needle guard eccentric cam with the flat part of the lower shaft.

Main Shafts

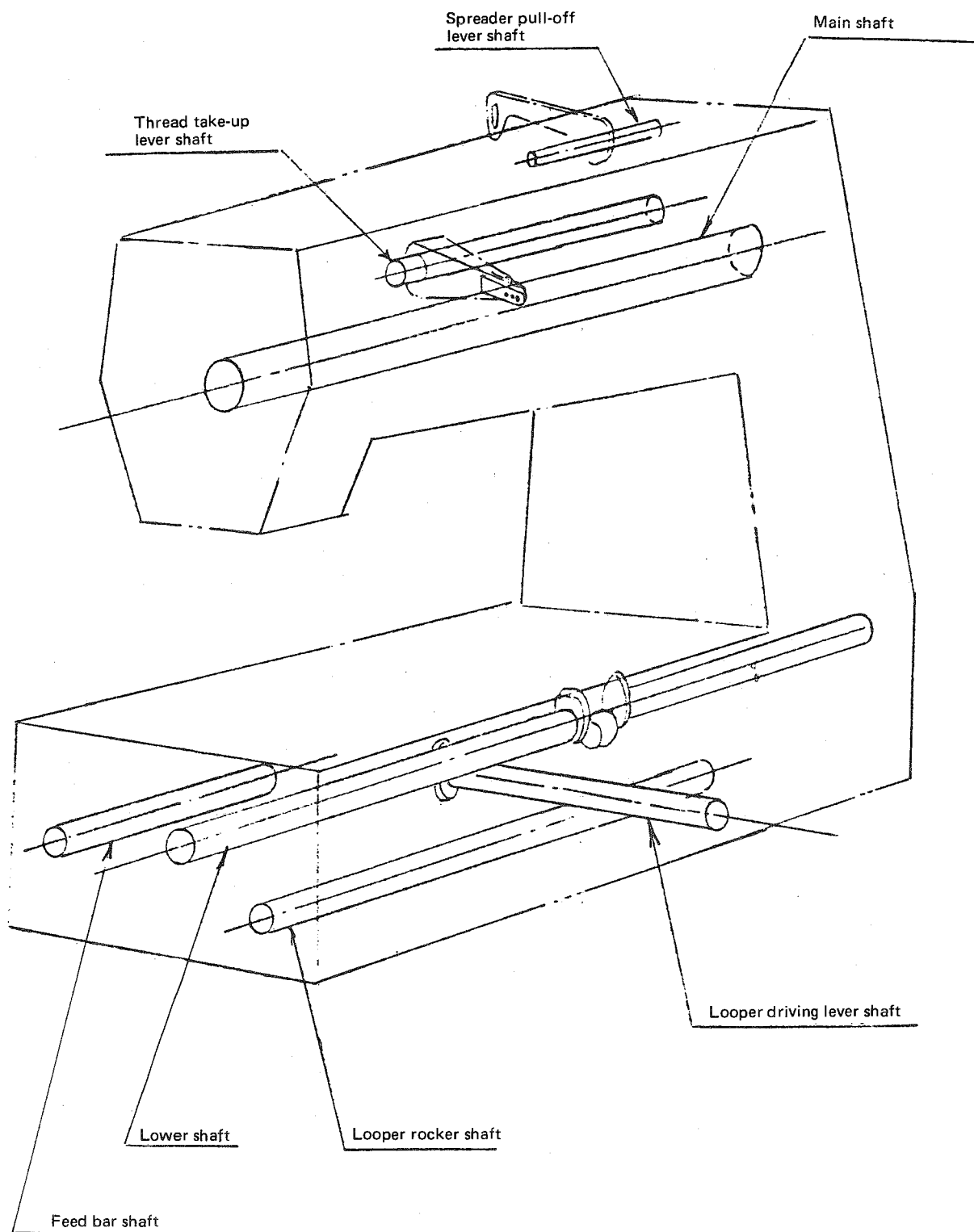

[Shafts and Thrust Collars of Main Components]

(1) Main shaft

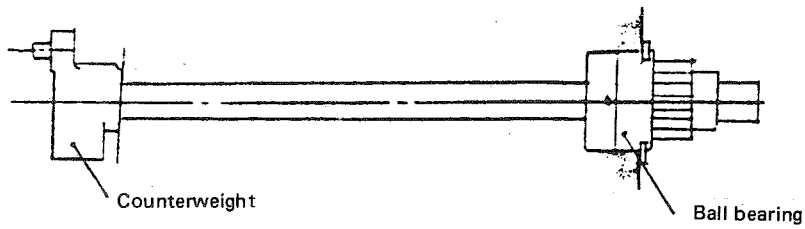

(2) Spreader pull-off lever shaft

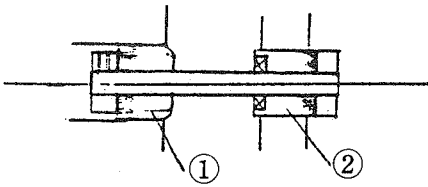

- ① Shaft retainer B B3925880000
- ② Bushing A B3924880000A

(3) Thread take-up lever shaft

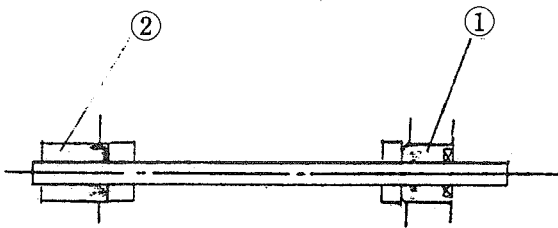

- ① Bushing, front B1906850000
- ② Bushing, rear B1907850000

(4) Lower shaft

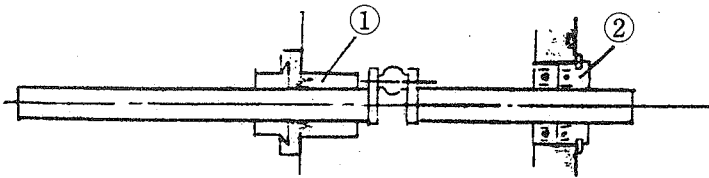

- ① Lower shaft bushing B B1803850000
- ② Ball bearing asm.

(5) Looper rocker shaft

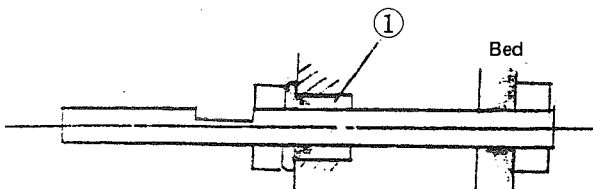

- ① Bushing, rear B2521850000

(6) Looper driving lever shaft

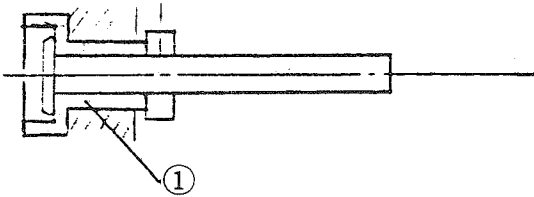

① Bushing, rear

B2503850000

(7) Feed rocker arm

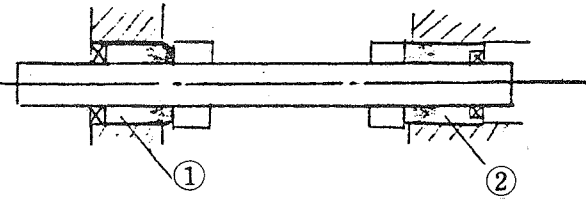

① Bushing, front

B1605850000A

② Bushing, rear

B1606850000A

(8) Looper rocker frame collar

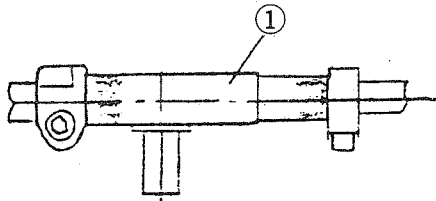

① Looper rocker frame collar B2522850000

5. OPERATION

(1) Needle

The standard needles for MF-860N Series machines are UY128GAS #65~#90.

(2) Thread

(Type of thread)

Cotton thread	#80~#50	(#60)
Spun thread	#60~#50	(#60)
Tetoron thread	#60~#30	(#50)
Woolly nylon thread	211 ^{DN} , 210 ^{DN} , 110 ^{DN}	
etc.		

The parenthesized numbers indicate the standard counts.

Needle thread	211 ^{DN}
Looper thread	210 ^{DN}

(3) How to use the thread guard

The thread guard is shown by ① in the figure below.

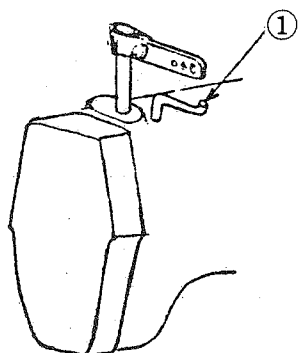

- The machine head is equipped with the thread guard. There are two types of thread guard; a thread guard (B1176860000) which receives all the three threads, and a right thread guard (B1175860000) which receives only the right thread.
- The thread guards are used to make the loops of the needle thread larger. However, the thread guards are seldom required for ordinary stitching.
- Properly use the right thread guard in accordance with the clause containing the corrective measures against stitch troubles.

(4) Thread take-up lever thread guide (silicone oil lubricant unit)

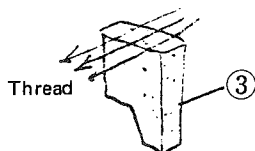
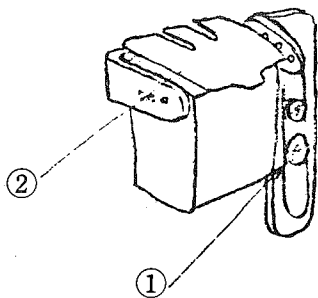

- The thread take-up lever thread guide (silicone oil lubricant unit) functions to apply silicone oil to the needle threads to make them smoother, thereby securing even, beautiful, and well-tightened stitches. It is also effective for preventing thread breakage due to needle heat.
- When the amount of silicone oil applied to the needle thread is required to be controlled, open cover ②, and reduce the contact between felt ③ and the threads.
- The appearance of stitches can be changed slightly by moving the whole thread guide up or down after loosening screw ①. However, this must not be used for the corrective measures against skip stitching, etc.

(5) Needle cooler

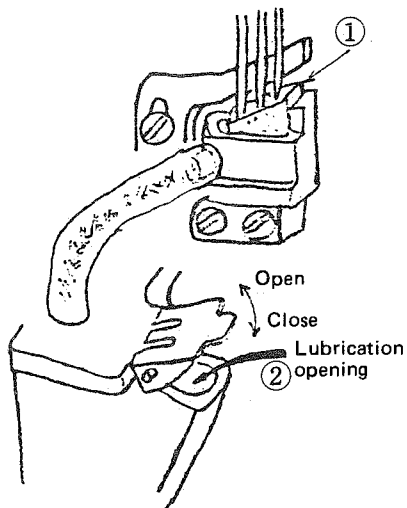

- (a) The needler cooler will effectively prevent thread breakage, foundation yarn breakage, or needle heating due to generation of heat.
- (b) Precautions for handling the needle cooler
 - Use the silicone oil supplied with the machine for cooling oil.
 - The lubrication opening ② through which the silicone oil is supplied is located on the left side under the looper cover as shown in the figure.
 - It will take much time for felt ① to absorb the oil supplied through the lubrication opening by capillary phenomenon. Accordingly, previously apply the oil to felt ①.
 - Replace a damaged felt with a spare felt.

(6) Front needle guard

The possibility of uneven stitches may grow higher as the sewing speed of the machine increases due to needle vibration.

This front needle guard will effectively prevent such troubles as needle breakage and stitch skipping by holding the needles in cooperation with the rear needle guard at the time when the looper catches the loops of the needles.

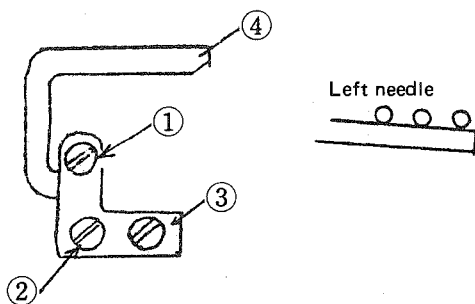

How to Install the Front Needle Guard

- (a) Fix needle guard holder ③ to looper rocker frame collar by screw ② so that the needles and needle guard ④ are at right angles to each other.
- (b) Loosen screw ①, and set the needle guard so that it presses the left needle by approx. 0.1 mm.

(7) Looper thread tension disc

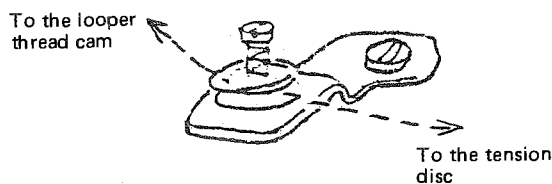

- Do not pass woolly nylon thread #110 or #210 through the tension disc.
- Pass other types of thread through the tension disc.

6. ADJUSTMENT

[1] Fundamental Adjustment

(1) Amount of looper's retreat

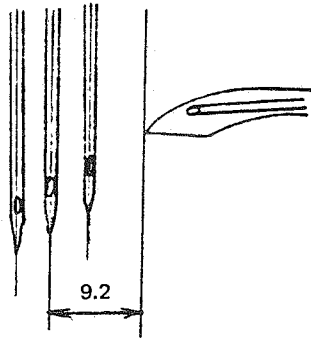

The distance from the looper's blade point to the center of the middle needle should be 9.2 mm when the looper has gone back to its farthest position.

Set the proper amount of the looper's retreat by the timing gauge as illustrated.

Use the following timing gauges for the throat plates indicated below:

Throat plate	Timing gauge
R4354FOHGOB	←→ B9101860B00
R4354FOHGOB	←→ B9101860E00

(Caution) Note that the amount of the looper's retreat is the key factor in making adjustment of the looper. Accordingly, failure to obtain a correct amount of the looper's retreat will make it totally impossible to perform any proper adjustment of the looper.

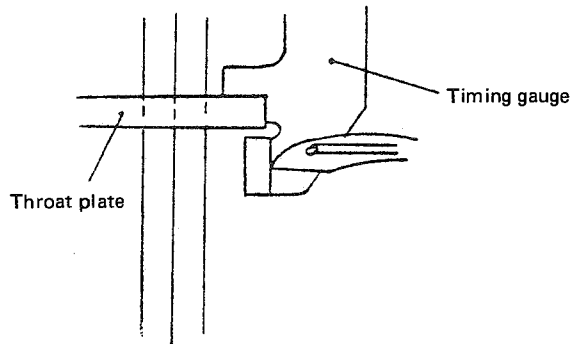

(2) Timing of the needles and the looper

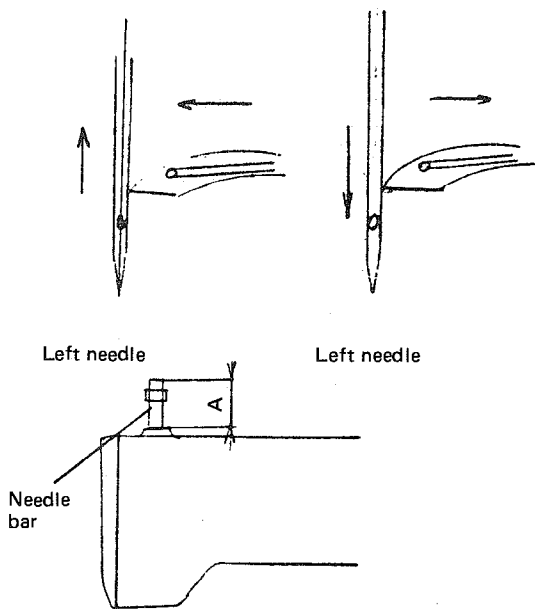

The timing is determined by comparing the distance ($A = a$) at which the right edge of the left needle reaches the looper's blade point when the looper advances with that ($A = b$) when the looper goes back.

The standard timing is represented by a difference (between a and b) of 0.5 or less ($|a - b| \leq 0.5$.)

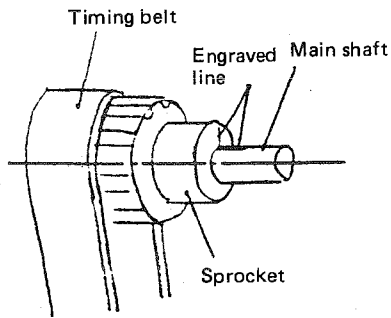

Easier Method to Set the Proper Timing

A required timing is obtained by making the engraved line on the main shaft in alignment with that on the sprocket. However, if the timing belt is not properly engaged, no correct timing is provided even when the two engraved lines are in alignment. In this case, correct the engagement of the timing belt.

Incorrect engagement of one pitch will lead to 15° discrepancy.

(3) Height of the needle bar

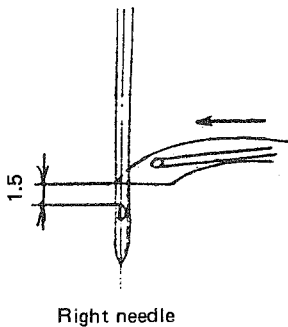

Adjust the height of the needle bar so that the distance from the looper's blade point to the upper edge of the right needle's eye becomes 1.5 mm when the looper's blade point reaches the left edge of the right needle as illustrated.

To make the above adjustment easily, use the timing gauge as shown in the figure for setting the proper height of the needle bar. At this time, **the needle bar is at its lowest position.**

The distance from the bottom surface of the needle clamp to the top surface of the throat plate should be 13.8 mm.

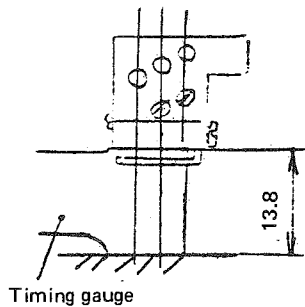

(4) Clearance between the needles and the looper

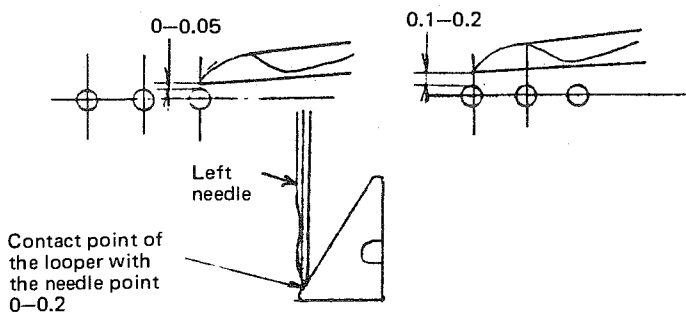

- ① The clearance between the right needle and the looper's blade point should be 0 to 0.05 mm.
- ② The clearance between the left needle and the looper's blade point should be approx. 0.1 to 0.2 mm.
- ③ The looper's back should come in contact with the left needle's point within a range of 0 to 0.2 mm.

(4-1) Needle guard

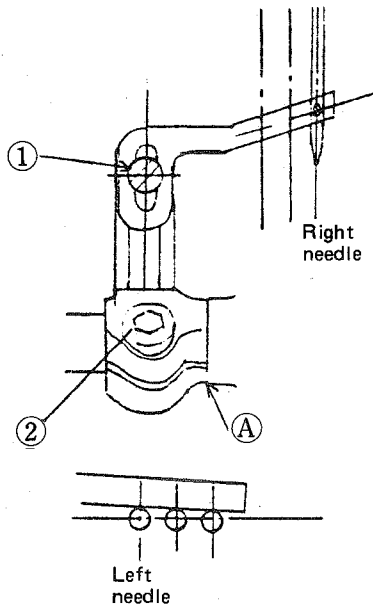

- ① Adjust the height of the needle guard so that the center of the right needle's eye is aligned with that of the needle guard.
- ② Set the needle guard so that it presses the left needle slightly (0 to 0.05 mm).
Adjust the pressure of the needle guard applied to the left needle by moving the needle guard holder after loosening screw ②. At this time, take care not to give any clearance to section A which controls the looper's thrust.

(4-2) Looper avoid eccentric cam

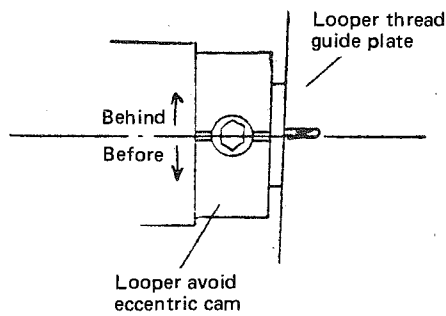

- ① In principle, the looper avoid eccentric cam should be set so that its engraved line is aligned with the engraved line on the looper thread guide plate, when the needle bar is at its highest position.
- ② When the engraved line on the cam is located before that on the looper thread guide plate, the trajectory of the looper will be as indicated by A in the figure, and when located behind, the looper will follow the trajectory represented by B.
- ③ To provide the clearance between the needles and the looper required in the clause (4), adjust the looper avoid eccentric cam within a distance equivalent to a summed thickness of two or three engraved lines.

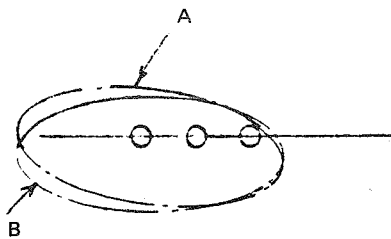

(4-3) Adjusting the looper avoid

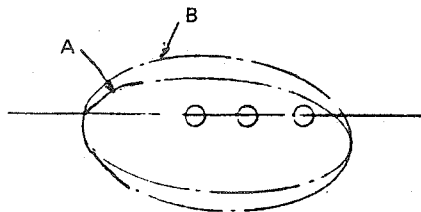

The looper avoid is used to adjust the looper's trajectory as shown in the figure on the left.

The trajectory is adjusted for the following two purposes;

- ① To adjust the clearance between the needles and the looper, and
- ② To adjust the meeting point of the looper's back and the needle.

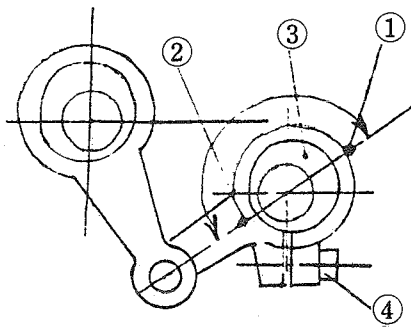

Adjusting Procedure

- Loosen screw ④, and perform adjustment by bushing ③.
- When the red engraved point on bushing ③ is at position ① shown in the figure, the greatest width ⑥ of the looper's track is provided, and when the red point is at ②, the smallest width ⑤ is given.
- Adjust the clearance in accordance with the count of a needle used, by moving the red engraved point within a range from ① to ②.

(5) Looper thread cam

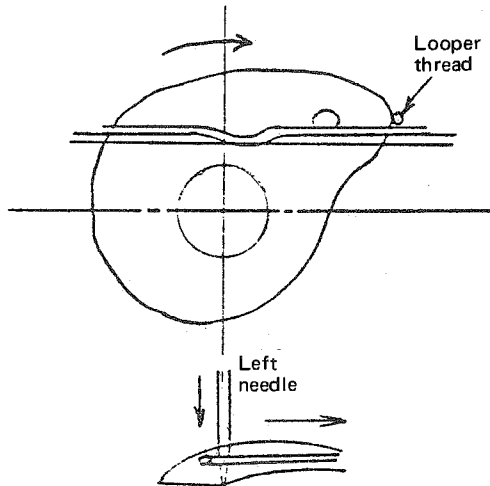

Set the looper thread cam so that a looper thread leaves the cam when the left needle's point has reached the ridge of the looper.

(6) Spreader

(a) Stroke

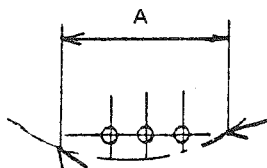

The spreader's stroke represented by A in the figure is changed in accordance with the needle gauge.

The following table shows strokes of the spreader for each needle gauge.

Needle gauge	Stroke
3.2	14.3 mm
4.0	15.1
4.8	15.9
5.6	16.7
6.4	17.5

(b) Adjusting procedure of the stroke

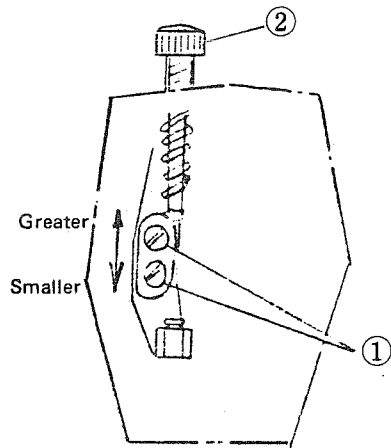

When the face plate is removed, two screws ① for adjusting the stroke are found. Remove screw ②, and loosen screws ① to move their washer up and down to adjust the spreader's stroke. As the washer is moved upward, the stroke grows bigger, and vice versa.

(Note) Upon completion of the stroke adjustment, retighten screws ① by a big screwdriver.

(c) Adjusting the height and position

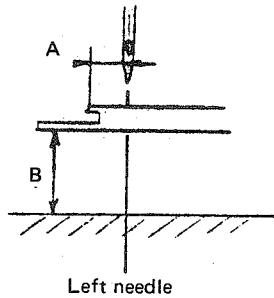

Adjust the protrusion A within a range of 4.5 to 5.5 mm, and the height B within a range of 8.5 to 9 mm.

Adjust the clearance C so that it becomes 0.5 to 1.0 mm when the spreader's blade point has come closest to the right needle.

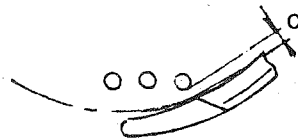

(7) Thread guide

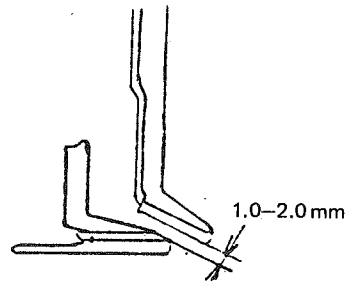
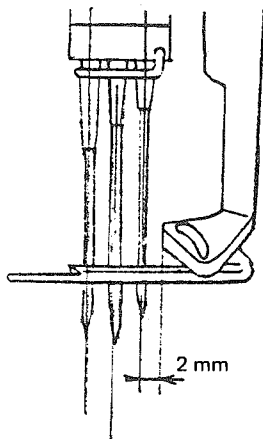

Position the thread guide as shown in the above figure.

(a) The distance from the center of the right needle to the tip of the thread guide is 2 mm.

(b) Provide a 1.0 to 2.0 mm clearance between the thread guide and the spreader.

Perform the adjustment described in the above clauses (6) and (7) through actual trial stitching.

(8) Auxiliary thread take-up lever

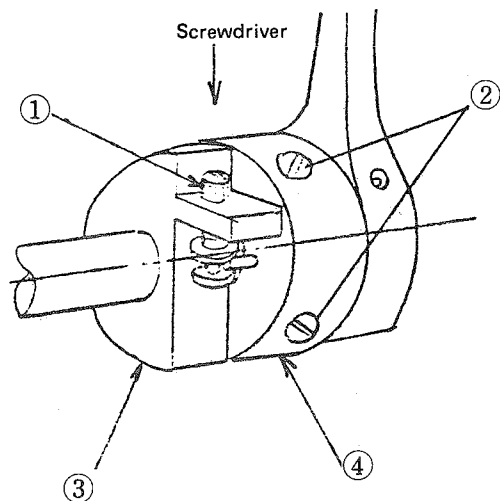

(a) The auxiliary thread take-up lever is designed to allow minute and easy change of its timing according to the stitching conditions.

The auxiliary thread take-up lever **controls the size of a needle thread loop** by changing the phase in relation to the needle bar.

(b) Adjusting procedure

Loosen two screws ③ of thread take-up lever cam ④, and turn timing adjusting screw ①. As the timing adjusting screw is turned clockwise, the needle thread loops become smaller, and vice versa.

Upon completion of the adjustment, securely retighten screws ②.

(Caution) Do not touch the screw of timing adjusting thrust which is fixed on the flat part of the main shaft.

(c) Adjusting the stroke

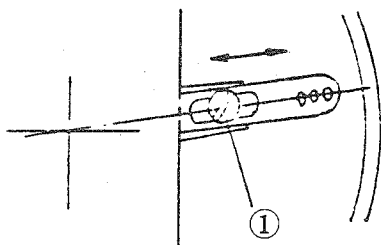

To adjust the stroke of the auxiliary thread take-up lever, loosen screw ①, and adjust the effective length of the lever. The standard stroke is obtained by fixing the screw in the middle of the slot.

The stroke is adjusted mainly for the purpose of reducing the tightness of stitches.

(9) Feed dog

(a) Adjusting the height of the feed dog

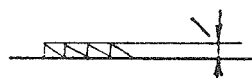

The teeth of the feed dog should project 1 mm from the top surface of the throat plate when the feed dog has reached its highest position.

(b) Adjusting the stitch length

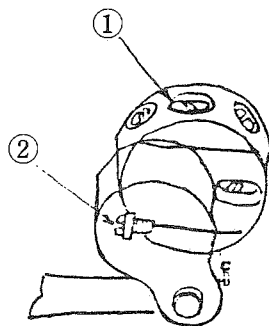

After loosening screw ① (with the bigger head), turn adjusting screw ② to adjust the stitch length.

Turn adjusting screw ② clockwise to reduce the stitch length, or turn it counterclockwise to increase the stitch length.

After setting a stitch length, firmly retighten screw ①.

Adjustable range of the stitch length

1.6 mm to 3.2 mm (16 stitches/in. to 8 stitches/in.)

(c) Adjusting the differential feed ratio

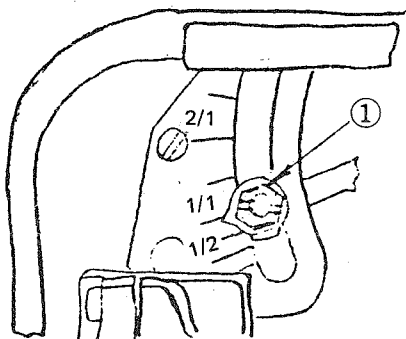

Loosen nut ①, and move it up or down within the slot to obtain a required ratio of differential feed.
The numerals engraved on the guide plate have a meaning explained below;

(Example) 2/1 2 . . . Differential feed } 2 differential feeds
 1 . . . Main feed } for 1 differential feed

Max. differential feed ratio

Gathering – 1:1/3 Stretching – 1:3

(Note) The gathering ratio of 1:1/3 may not be possible for some stitch lengths.

(d) Positioning the feed dog

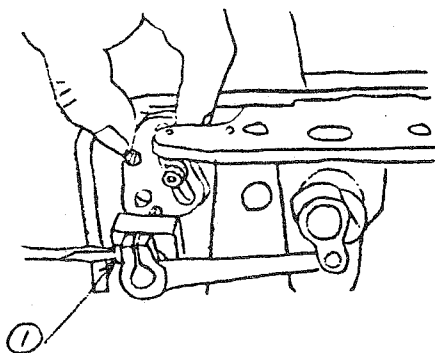

Loosen screw ①, set the feed pitch to the maximum, and position the feed dog so that it does not come in contact with the throat plate during its motion.

(e) Positioning the differential feed dog

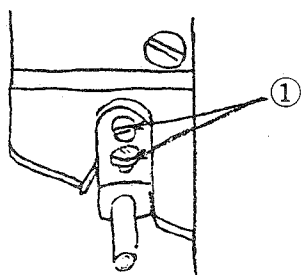

Loosen two screws ① shown in the figure to adjust the position of the differential feed dog.
With the feed pitch set to the maximum and the differential feed ratio to 3/1, fix the differential feed dog so that it does not come in contact with the throat plate.

(Note) This positioning of the differential feed dog is applied to MF-860EDM (for covering stitch), for example.

(f) Phase of feed

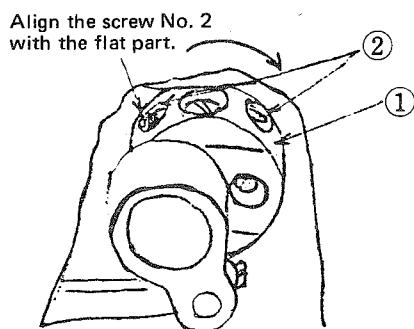

The phase of the vertical and longitudinal feed is determined by the flat parts.

Align the screw No. 1 of the feed driving eccentric cam to the flat part (vertical), and the screw No. 2 of feed crank stud ① to the flat part of the lower shaft.

(Caution) Do not loosen screw ② except for some special reasons, since feed crank stud ① is lubricated through the lower shaft.

If screw ② has been loosened, retighten it with feed crank stud ① pressed against the lower shaft.

[Principle of Stitch Formation]

(1) The looper is at its utmost retreated position.

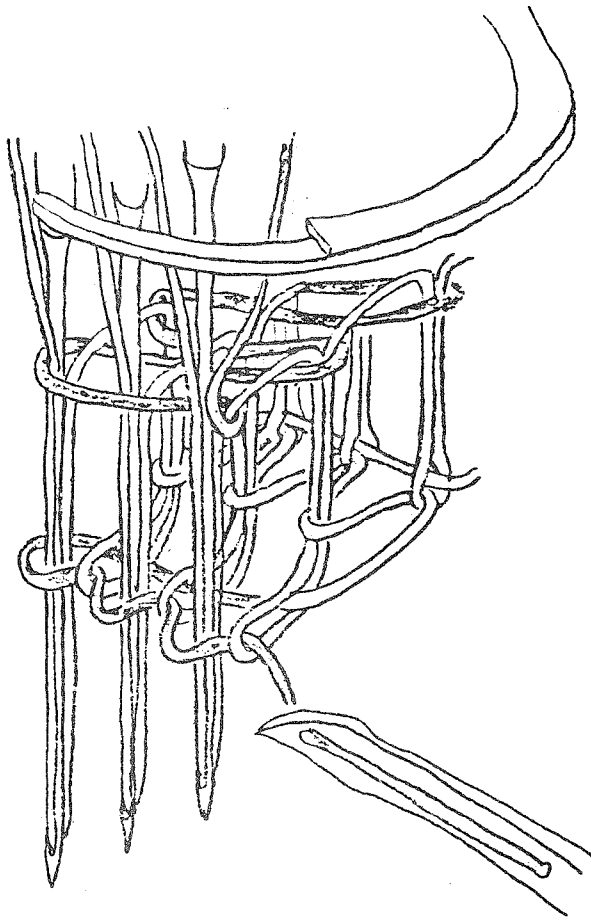

(2) The looper is catching the needle threads.

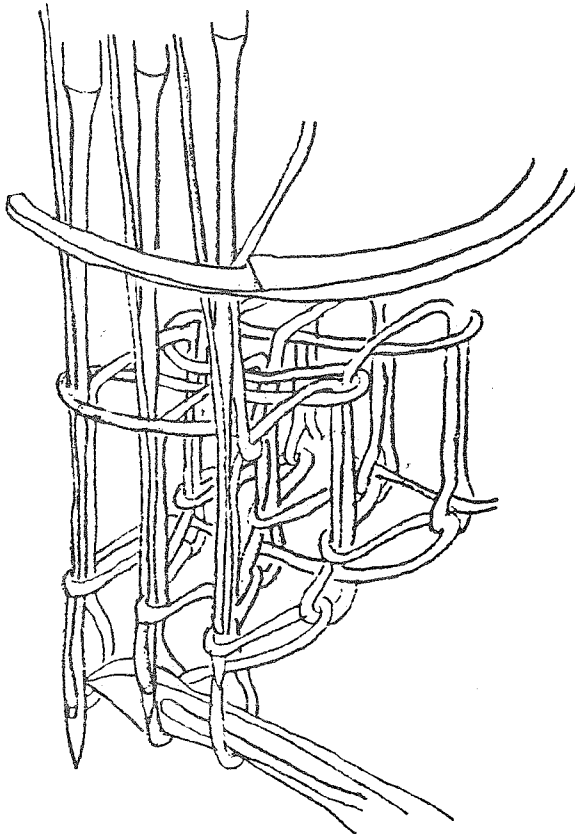

(3) The looper is at its utmost advanced position.

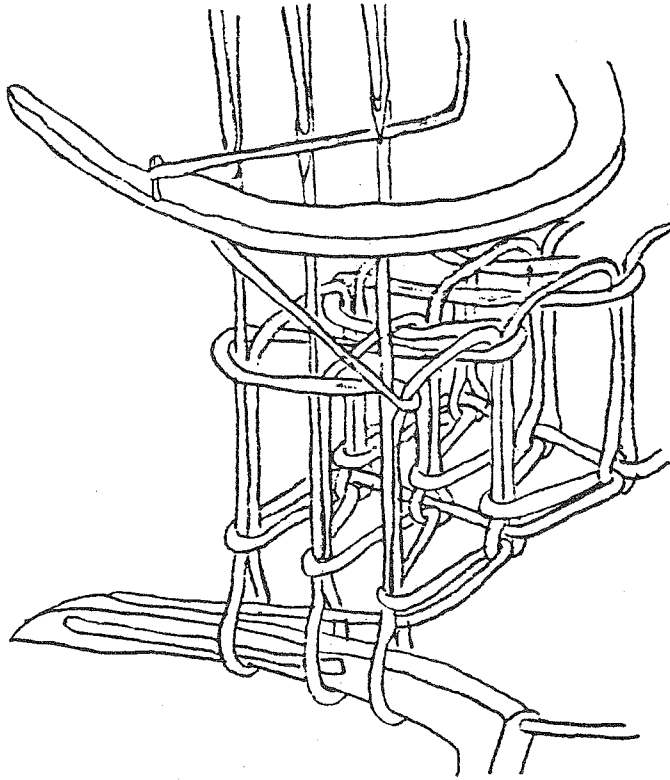

(4) The looper thread is being hooked.
After this, the looper goes back farthest again, and repeats the above steps.

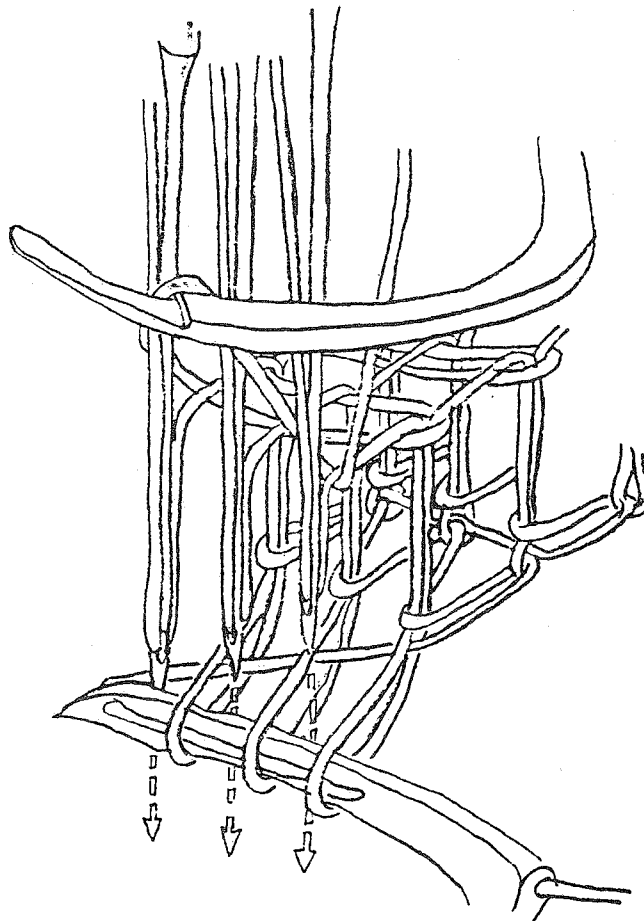

7. CORRECTIVE MEASURES AGAINST DEFECTIVE STITCHING

Note that the following corrective measures are provided on the assumption that the fundamental adjustment has been correctly made. (The following troubles will seldom occur when the fundamental adjustment has been properly made.)

(1) Stitch skipping (bottom covering stitches)

(a) Stitch skipping occurs in the right thread

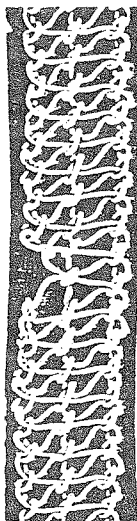

(Cause)

If the looper has failed to catch a thread loop of the right needle, a defective stitch as shown on the left will result. In this case, the stitch skipping is caused by a too small or no loop of the needle thread.

(Corrective measures)

- ① Turn the timing adjusting screw of the auxiliary thread take-up lever counterclockwise to advance the phase of the auxiliary thread take-up lever.
 - ② Install a right thread guard in order to pull out the right thread a little near at the lowest point.
- The problem should be solved either by ① or ②.

(b) Stitch skipping occurs in the left thread

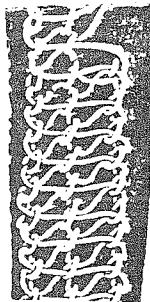

(Cause)

If the looper has failed to catch a thread loop of the left needle, a defective stitch as shown on the left will result. In this case, the stitch skipping is caused by a too large loop of the needle thread.

(Corrective measures)

- ① Turn the timing adjusting screw of the auxiliary thread take-up lever clockwise to delay the phase of the auxiliary thread take-up lever.
- Perform this correction while checking the size of a loop.

(c) Stitch skipping occurs in the right and left threads

The troubles described in the above (a) and (b) take place at the same time, and the same defective stitches as (a) and (b) result.

(Cause)

Same as (a) and (b).

(Corrective measures)

- ① Delay the phase of the auxiliary thread take-up lever as described in (b).
 - ② Install a right thread guard to provide larger loops of the right needle thread.
- The stitch skipping of the right and left threads should be corrected by combining the above two corrective measures ① and ②.

(d) Stitch skipping occurs in the middle and left threads



(Cause)

The defective stitch illustrated on the left will result if the thread loops of the middle and left needles are not caught at the same time.

This trouble is caused by too large thread loops of the needles.

(Corrective measures)

Same as those for stitch skipping in the left thread.

(e) Stitch skipping occurs in the right, middle, and left threads

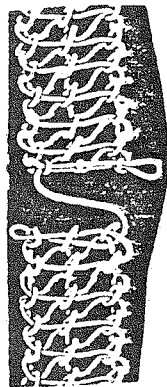

(Cause)

The defective stitch shown on the left will result if the thread loops of the right, middle, and left needles are not caught at the same time.

However, this trouble rarely occurs.

(f) Stitch skipping of the left thread occurs on the back of a stitch



(Cause)

The defective stitch shown on the left will result if the left needle thread has failed to enter the triangle formed by the back of the looper, needle threads, and the looper thread.

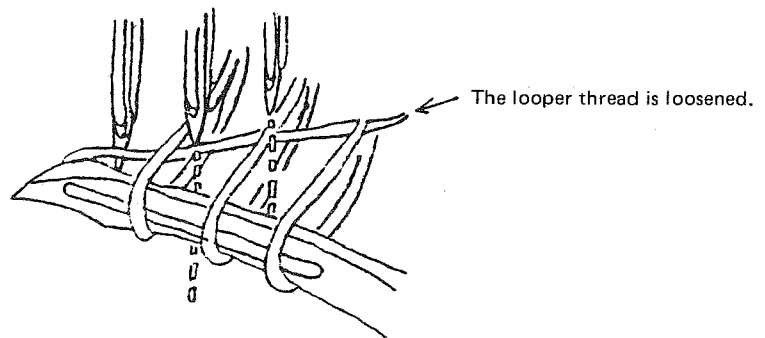

(Corrective measures)

- ① Check whether or not the looper thread tension disc is threaded.
- ② Check the chain looper thread guide for proper timing.

(g) Stitch skipping of all the threads occurs on the back of a stitch

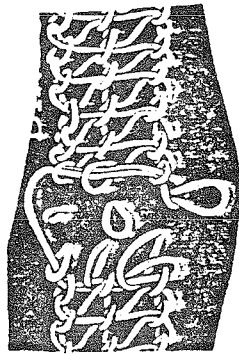

(Cause)

The defective stitch illustrated on the left will result if all the left, middle, and the right needle threads have failed to enter the triangle described in the above (f)

(Corrective measures)

Same as (f)

(h) The middle thread thoroughly slips out

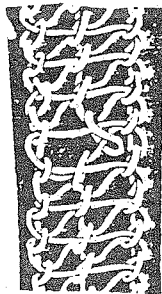

(Cause)

The defective stitch as illustrated will result if the middle needle thread has entered the triangle in the wrong way as illustrated on the left.

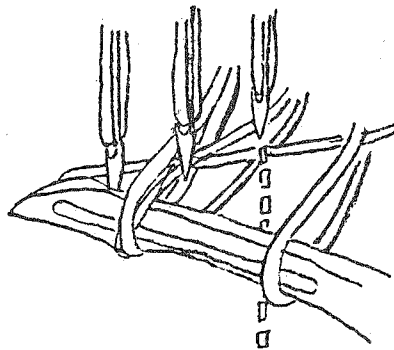

(Corrective measures)

Refer to "Corrective measures against single-thread chainstitches and thread slipping-out" described later.

(i) The right thread thoroughly slips out (or single-thread chainstitches are formed)

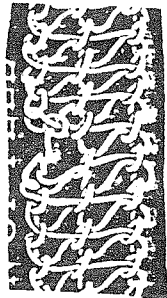

(Cause)

The defective stitch as illustrated will result if the right needle thread has entered the triangle in the wrong way as illustrated on the left.

(Note) A single-thread chainstitch consists of only the right thread, and differs from the defective stitch shown on the left.

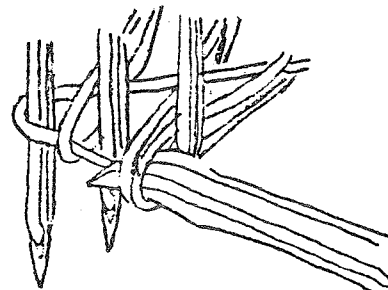

(Corrective measures)

Refer to "Corrective measures against single-thread chainstitches and thread slipping-out".

(2) Stitch skipping occurs in the top covering stitches

(a)

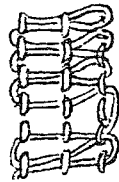

(Cause)

The defective stitch as illustrated on the left will result if the spreader fails to catch the top spreader thread when it begins to move forward from its utmost retreated position.

(Corrective measures)

- Correct the retreat stroke (too large) of the spreader.
- Correct the height of the thread guide (too high) of the spreader.

(b)

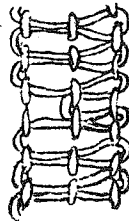

(Cause)

The defective stitch as illustrated on the left will result if the left needle fails to enter the triangle of the covering thread when the spreader begins to move back from its utmost advanced position.

(Corrective measures)

- Increase the protrusion of the spreader.
- Reduce the clearance between the spreader and the right needle.

8. CORRECTIVE MEASURES AGAINST SINGLE-THREAD CHAINSTITCHES AND THREAD SLIPPING-OUT

(1) Type of stitching failures

① Thread slipping-out

See the illustration in (h) and (i). (The illustrations show only the right and middle threads because the left thread is seldom involved in this type of trouble.)

② Single-thread chainstitch



Single-thread chainstitch consisting only of the right or middle thread as shown on the left are formed.

The above troubles ① and ② are classified as stitch skipping.

(2) Corrective measures – Checking points

- Check the needles and the looper for the following:
 - Is the looper's retreating stroke set to 9.2 mm (nearer to the middle needle)?
 - Is the height of the needle bar set to 13.8 mm?
 - Is the timing of the needles in relation to the looper properly set?
- Check the looper thread for excessive tension.
- Check the needle thread loops.
 - If they are too large, delay the timing of the auxiliary thread take-up lever.
- Is a correct throat plate used?
 - Check it on the previous table under the clause (2) "Application vs. Model".
- Check the needle thread or threads involved in the trouble for insufficient tension.
- Check whether the needles (with smaller needle gauges) are installed straight.

(Note) If the above problems are not solved by the corrective measures described in (2), burnish the ridge lines of the looper and the projections in the opening of the throat plate.