

JUKI®

2-3 Needle Flat Bed Coverseam Machine

MF-7000 Series

2-3 Needle Cylinder Bed Coverseam Machine

MFC-7000 Series

ENGINEER'S MANUAL

29275609

No.02

PREFACE

This Engineer's Manual is written for the technical personnel who are responsible for the service and maintenance of the machine.

This manual describes "Standard Adjustment" , "Adjustment Procedures" , "Results of Improper Adjustment", and other important information which are not covered by the Instruction Manual.

It is advisable to use the relevant Instruction Manual and Parts List together with this Engineer's Manual when carrying out the maintenance of these machines.

This manual gives the "Standard adjustment" on the former page under which the most basic adjustment value and on the latter page the "Results of improper adjustment" under which errors and troubles arise.

CONTENTS

1. SPECIFICATIONS	1
2. MOTOR AND BELT	2
3. MODEL NUMBERING SYSTEM	3
4. STANDARD ADJUSTMENT	7
(1) MF	7
1) Timing relation between the needle and the feed	7
2) Adjusting the timing relation between the needle bar and looper (synchronization) : Without gauges	7
3) Returning amount of the looper	9
4) Height of the needle bar	9
5) Clearance between the looper and needle	11
6) Adjusting amount of the looper-avoid	11
7) Position of the needle guard	13
8) Position of the feed dog	15
9) Spreader	17
10) Looper thread cam	19
11) Position of the presser bar	21
12) Position of the needle thread tension release (without thread trimmer)	21
13) Position and height of the presser foot	23
14) Position of the thread guide	23
(2) Thread trimmer device (MF)	27
1) Adjustment of the thread trimmer device	27
2) Thread tension release (Looper thread trimmer device)	29
(3) MFC	31
1) Timing relation between the needle and the feed	31
2) Adjusting the timing of the needle bar and looper (Synchronization) : Without gauges	31
3) Returning amount of the looper	33
4) Height of the needle bar	33
5) Position of the needle guard	35
6) Clearance between the looper and needle	35
7) Adjusting amount of the looper-avoid	37
8) Position of the feed dog	39
9) Spreader	41
10) Looper thread cam	43
11) Looper thread wrap-up preventing cam (Old type)	43
12) Position of the presser bar	45
13) Position of the needle thread tension release (without thread trimmer)	45
14) Position and height of the presser foot	47
15) Position of the thread guide	47
(4) Thread trimmer device (MFC)	51
1) Stroke adjustment (common to both electromagnetic and pneumatic type)	51
2) Adjustment of the right position of movable knife (return)	51
3) Adjustment of stationary knife and looper thread clamp spring	53
4) Adjustment of the position of movable knife's pointed end	53
5) Adjustment of operating speed of thread trimmer (pneumatic type)	55
6) Confirmation of thread trimming	55
7) Adjustment of pneumatic lifter	57
8) Adjustment of tension release (equipped with thread trimmer)	59
9) Adjustment of proximity switch	59
10) Adjustment of top covering thread trimmer	61
5. ASSEMBLING AND ADJUSTMENT OF FIXED CAM THREAD TAKE-UP	63
(1) Parts used	63
(2) Needle bar cam plate and needle bar fork thread take-up	65
(3) Needle thread guide and medium thread path base	65
(4) Spreader thread guide	67
1) Parts used	67
2) Assembling and adjustment of spreader thread guide	67
6. OTHER PRECAUTIONS	68
(1) Points to which Locktite is applied	68
7. TROUBLES AND CORRECTIVE MEASURES	69
8. DRAWING OF TABLE	84
(1) Semi-submerged type for MF	84
(2) Desktop type for MF	86
(3) Desktop type for MF with fabric under trimmer	87
(4) Desktop type for MFC	88
(5) Semi-submerged type for MFC	89
(6) Semi-submerged down table for MFC	90
(7) Table for MFC with tension roller	91

1. SPECIFICATIONS

MF-7000 Series

	MF-7406	MF-7407	MF-7602	MF-7605
Sewing speed	6,500 r.p.m. (Max)			
Stitch length	1.6 to 3.2 mm			
No. of needle	2	3	2	3
Needle gauge	3.2, 4.0	4.8, 5.6, 6.4	3.2, 4.0	4.8, 5.6, 6.4
Top covering	Without		With	
Diff. feed ratio	Gathering stitch 1 : 1.5		Stretching stitch 1 : 0.6	
Needle	UY128GAS #65 / 025 to #90 / 036			
Presser foot lift	8.1 mm			
Lubricating oil	JUKI specified oil (equivalent to ISO VG32) : Part No. 30149207			

MFC-7000 Series

	MFC-7406	MFC-7407	MFC-7602	MFC-7605
Sewing speed	6,500 r.p.m. (Max)			
Stitch length	1.6 to 3.2 mm			
No. of needle	2	3	2	3
Needle gauge	3.2, 4.0, 4.8	5.6, 6.4	3.2, 4.0, 4.8	5.6, 6.4
Top covering	Without		With	
Diff. feed ratio	Gathering stitch 1 : 1.5		Stretching stitch 1 : 0.6	
Needle	UY128GAS #65 / 022 to #90 / 036			
Presser foot lift	7 mm			
Lubricating oil	JUKI specified oil (equivalent to ISO VG32) : Part No. 30149207			

2. MOTOR AND BELT

MF-7000 Series

Sewing speed (r.p.m.)	50 Hz			60Hz		
	Motor pulley	V belt (inch)		Motor pulley	V belt (inch)	
	Outer dia. (mm)	Fully-submerged type	Semi-submerged type	Outer dia. (mm)	Fully-submerged type	Semi-submerged type
6500	140	35		120	35	
6000	125	35		105	35	
5500	110	35		90	34	
5000	100	34		85	34	
4500	90	34		75	34	
4000	80	34		70	34	
3500	70	34		60	33	

- 1) Use a clutch motor of 1/2 HP (400W).
- 2) Use an M type V belt.
- 3) The table above shows the sewing speed obtained by the use of motor pulleys with different diameters and V belts with different lengths.
- 4) Note that the effective diameter of the pulley of the machine head is 49 mm.

MFC-7000 Series

Sewing speed (r.p.m.)	50 Hz			60Hz		
	Motor pulley	V belt (inch)		Motor pulley	V belt (inch)	
	Outer dia. (mm)	Top mount type	Semi-submerged type	Outer dia. (mm)	Top mount type	Semi-submerged type
6500	145	43	40	120	41	38
6000	135	43	40	110	41	38
5500	120	41	38	100	41	38
5000	110	41	38	90	39	37
4500	95	41	38	80	39	37
4000	85	39	37	70	39	37
3500	75	39	37	60	38	35

- 1) Use a clutch motor of 1/2 HP (400W).
- 2) Use an M type V belt.
- 3) The table above shows the sewing speed obtained by the use of motor pulleys with different diameters and V belts with different lengths.
- 4) Note that the effective diameter of the pulley of the machine head is 57.5 mm.

3. MODEL NUMBERING SYSTEM

MF-7000 Series

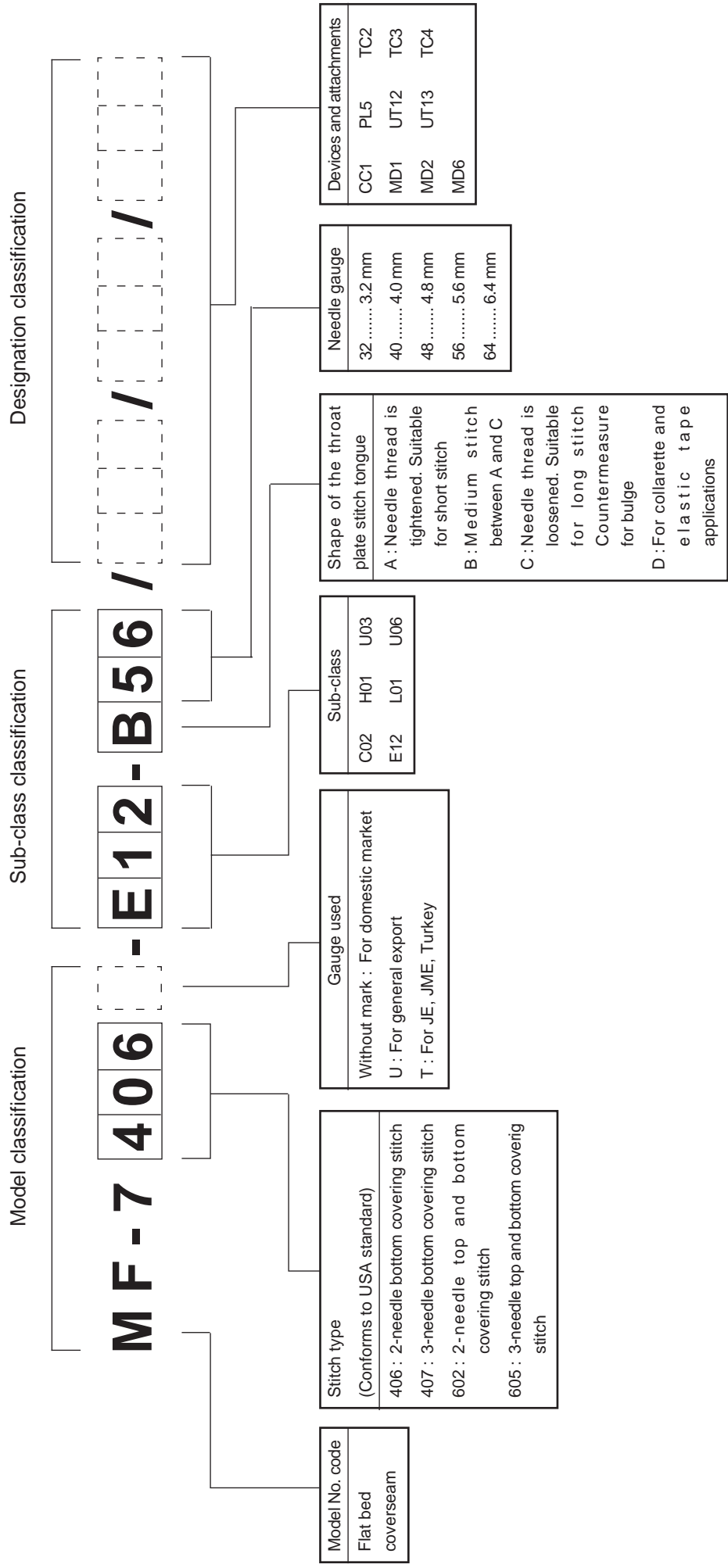

MFC-7000 Series

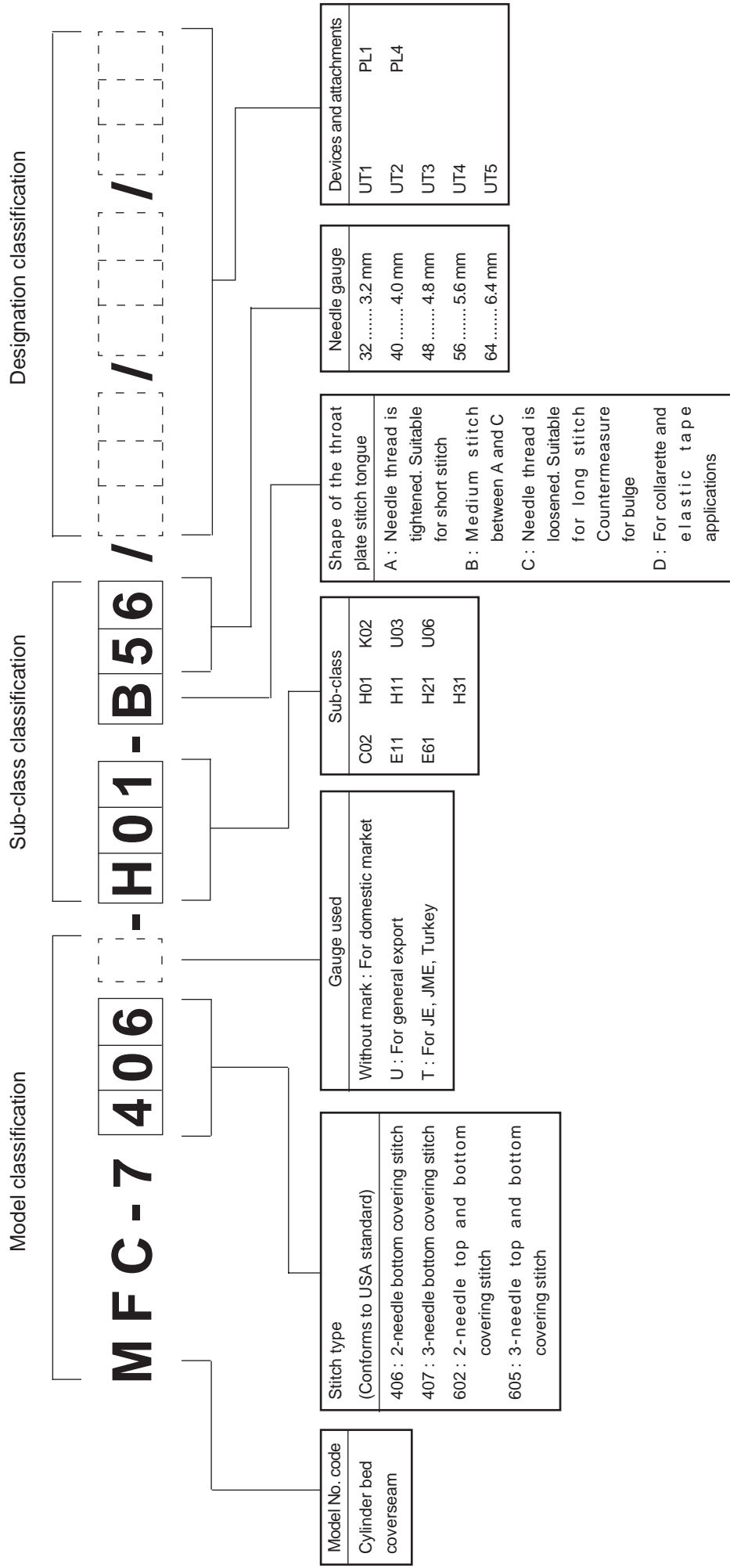

MF-7000 Series

Code	Specification	Description of sub-class
C02	For collarette	Basic style
E12	For elastic tape attaching	Fabric under trimmer and metering device (Upper side)
H01	For hemming	Basic style with hem guide
L01	For lap seam	Basic style
U03	Universal	Differential feed dog 3-row
U06	Universal	Differential feed dog 4-row

MFC-7000 Series

Code	Specification	Description of sub-class
C02	For collarette	Basic style
E11	For endless elastic tape attaching	With fabric under trimmer
E61	For endless elastic tape attaching	With fabric under trimmer and cloth puller
H01	For hemming	Basic style with hem guide
H11	For hemming	With cloth puller
H21	For hemming	Left hand fabric under trimmer
H31	For hemming	Left hand fabric under trimmer with cloth puller
K02	Covering	With adjustable seam guide for medium- to heavy-weight fabrics
U03	Universal	Differential feed dog 3-row
U06	Universal	Differential feed dog 4-row

Elastic tape cutter (MF-7000 Series)

Code	Description		Applicable model
TC2	Pneumatic type tape cutter	Single action air cylinder knee switch	E12, C02
TC3	Solenoid type tape cutter	Knee switch	E12, C02
TC4	Pneumatic type fast-action tape cutter	Double action air cylinder knee switch	E12, C02

Under-bed thread trimming device

Code	Applicable model	Solenoid type				Pneumatic type				
		Thread trimmer	Needle thread wiper	Top covering thread trimmer	Auto-lifter	Thread trimmer	Needle thread wiper (Mechanical)	Needle thread wiper (Pneumatic)	Top covering thread trimmer	Auto-lifter
UT1	MFC7406,7407									
UT2	MFC7602,7605									
UT3	MFC7406,7407									
UT4	MFC7406,7407									
UT5	MFC7602,7605									
UT12	MF7406,7407									
UT13	MF7602,7605									

Elastic tape metering device

Code	Description		Applicable model
MD1	Metering device (Upper side)	Electric single stage	MF 7406, 7407, 7602, 7605-E12
MD2	Metering device (Upper side)	Electric two stage	MF 7406, 7407, 7602, 7605-E12
MD6	Metering device (Upper side)	Mechanical type	MF 7406, 7407, 7602, 7605-E12

Under-bed thread trimming device

Code	Description		Applicable model
CC1	Pneumatic type chain-off thread cutter	Horizontal type	MF7602, MF7605

Cloth puller

Code	Description	Applicable model
PL1	Cloth puller	MFC 7406, 7407, 7602, 7605
PL4	Cloth puller Can be installed after machine set-up.	MFC 7406, 7407, 7602, 7605
PL5	Cloth puller Can be installed after machine set-up.	MF 7406, 7407, 7602, 7605

4. STANDARD ADJUSTMENT

(1) MF

Standard Adjustment

1) Timing relation between the needle and the feed

First screw **A** in operating direction on double eccentric **1** of feed drive assembly must be straight up, when the needle bar is at bottom of stroke.

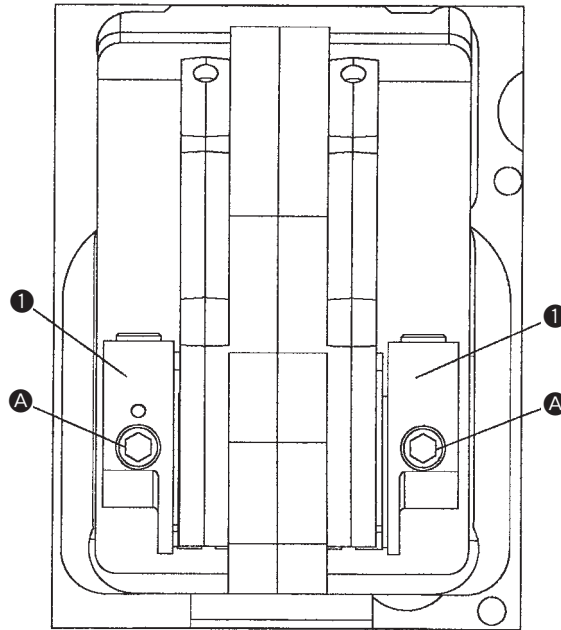

2) Adjusting the timing relation between the needle bar and looper (synchronization) : Without gauges

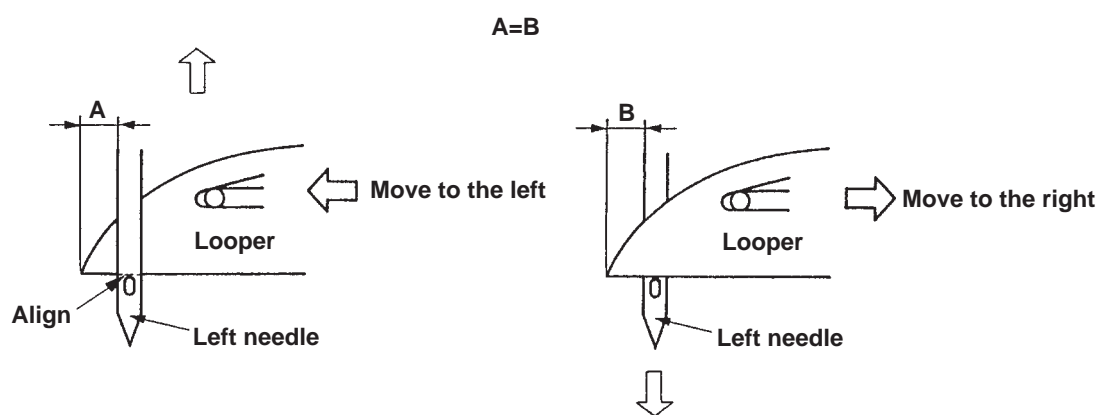

When the blade point of the looper moves to the left in the rear of the needle and to the right in front of the needle, align the upper end of the eyelet of the left needle with the lower face of the looper so that the distance between A and B, the side of the left needle to the blade point of the looper, should be equal.

Adjustment Procedures	Results of Improper Adjustment
<ul style="list-style-type: none"> ○ Remove top cover, feed cover, gasket and cloth plate. ○ Loosen screws B of sprocket 2. ○ Rotate lower main shaft in operating direction counterclockwise, until the first screw A on double eccentric 1 is straight up. ○ Holding pulley to prevent it from turning, rotate handwheel of upper main shaft until needles are at top of their stroke. ○ Adjust the torque of screws B to 5.2 to 5.4 Nm and tighten the screws. ○ Replace top cover, feed cover, gasket and cloth plate. <div data-bbox="411 678 721 1039" data-label="Image"> </div> <p data-bbox="172 1167 687 1196">Note : Earlier machines have (4) screws.</p>	<ul style="list-style-type: none"> ○ Needle breakage ○ Looper fails to catch needle thread.
<ul style="list-style-type: none"> ○ Dimension A : Turn handwheel in operating direction until bottom of looper is even with top of needle eye. ○ Dimension B : Continue turning handwheel in operating direction until bottom of looper is even with top of needle eye when looper is in front of needle. ○ If dimension A is greater than dimension B <ul style="list-style-type: none"> 1) Loosen C on sprocket 3. 2) Fixing looper, turn pulley and tighten screws C so that sprocket 3 can turn in operating direction. Repeat above steps until dimension A = dimension B. ○ If dimension A less than dimension B <ul style="list-style-type: none"> 1) Loosen screws C on sprocket 3. 2) Fixing looper, turn pulley and tighten screws C so that sprocket 3 can turn in reverse direction. Repeat above steps until dimension A = dimension B. <div data-bbox="258 1733 831 2074" data-label="Image"> </div>	<ul style="list-style-type: none"> ○ If the timing is not correct, skip stitching may occur.

Standard Adjustment**3) Returning amount of the looper**

When the looper is in the extreme right position, the distance between the blade point of the looper and the center of the right needle is 4.4 ± 0.1 mm.

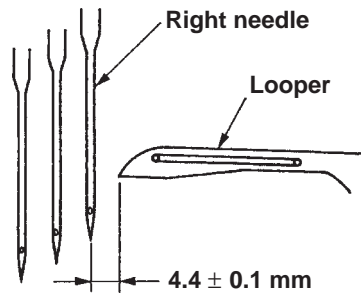
**4) Height of the needle bar**

When the looper moves to the left and the blade point of the looper comes out from the left side of the left needle by 0.7 to 1.0 mm, the lower face of the looper aligns with the upper end of the eyelet of the left needle.

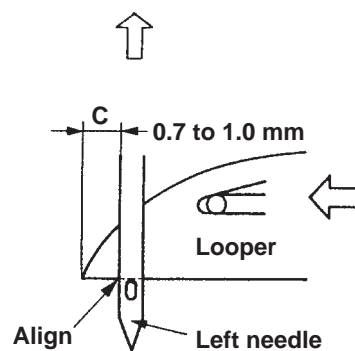

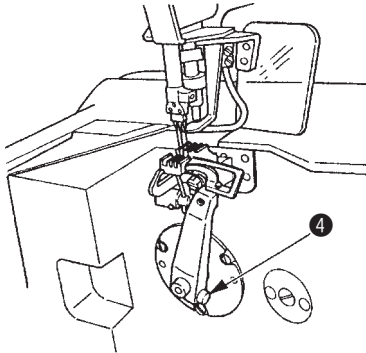
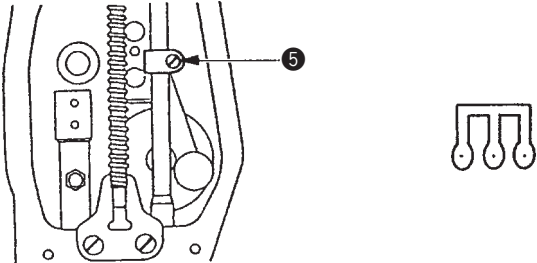
Adjustment Procedures	Results of Improper Adjustment
<ul style="list-style-type: none"> ○ Loosen the looper base setscrew ④ and adjust the returning amount of the looper. (Use a 5/32 inch hexagonal wrench.) 	<ul style="list-style-type: none"> ○ If the returning amount is large, skipping stitch and tangling stitch may occur and the range of the thickness of the cloth to be sewn is reduced. ○ If the returning amount is small, skipping stitch and tangling stitch may occur.
<ul style="list-style-type: none"> ○ Loosen the needle bar holder screw ⑤ and adjust the height of the needle bar. <p>(Caution) After the adjustment, check that the direction of the needle clamp is correct and the respective needles enter the center of the holes of the throat plate.</p> 	<ul style="list-style-type: none"> ○ If the distance of C is large, skip stitching and tangling stitch may occur. ○ If the distance of C is small, skip stitching and tangling stitch may occur. ○ If defective stitch occurs with the wooly nylon thread, make the distance C as small as possible.

Standard Adjustment

5) Clearance between the looper and needle

Clearance between the blade point of the looper and the grooves of the right/left needles is 0 to 0.05 mm. (Clearance of the middle needle becomes larger a little.)

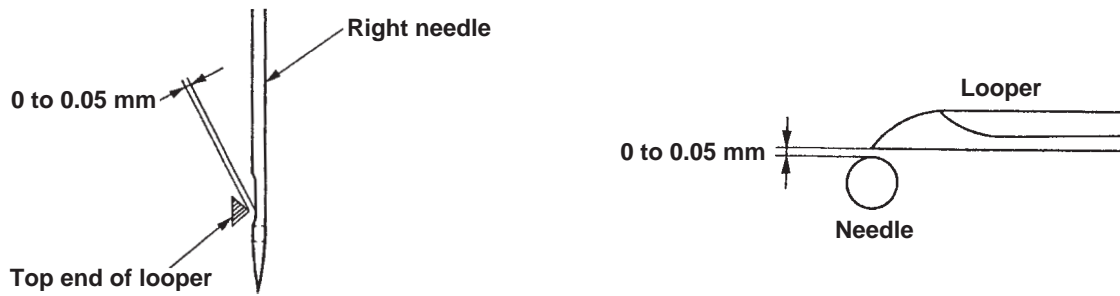

6) Adjusting amount of the looper-avoid

When the needle descends, the top point of the needle touches the back of the looper at the position of $\frac{2}{3}$ from the upper side of the looper.

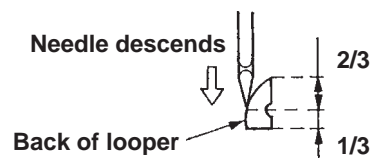

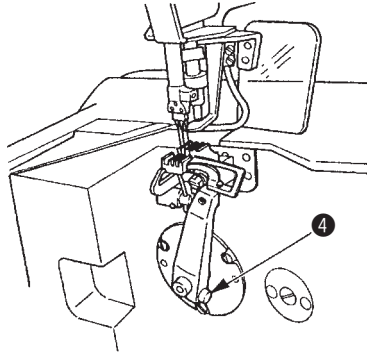
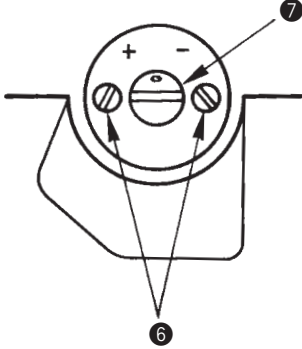
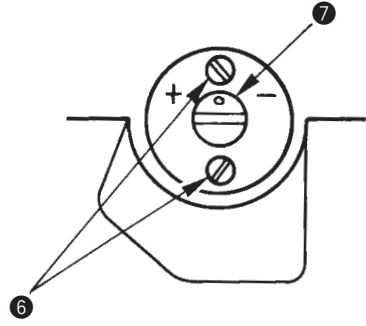
Adjustment Procedures	Results of Improper Adjustment
<p>○ Loosen the looper base setscrew ④ and adjust by moving the looper base back and forth.</p> 	<ul style="list-style-type: none"> ○ If the clearance is too large, the loop of the needle thread is not scooped and the back of the looper hits strongly the top point of the needle which causes the damage of the needle point. ○ If the clearance is too small, skipping stitch will occur due to the damage of the tip of the looper, the needle breakage, and the large clearance between the back of the looper and the needle.
<ul style="list-style-type: none"> ○ Loosen the two screws ⑥ and adjust by rotating the eccentric pin ⑦. ○ Amount of the avoid increases in the direction of +. ○ Amount of the avoid reduces in the direction of -. <p>(Caution) After the adjustment, check again the clearance between the blade point of the looper and the groove of the needle. Then check the contact on the back of the looper.</p> <div style="display: flex; justify-content: space-around;"> <div data-bbox="199 1563 502 1971"> <p>Old type</p>  </div> <div data-bbox="550 1563 917 1926"> <p>New type</p>  </div> </div>	<ul style="list-style-type: none"> ○ If the amount of the avoid is large, the clearance of the back of the looper and the needle becomes large, and skipping stitch and tangling stitch will occur. ○ If the amount of the avoid is small, the needle hits strongly the back of the looper. This causes the damage of the needle point, the needle breakage and the damage on the back of the looper.

Standard Adjustment**7) Position of the needle guard****① Rear needle guard**

- The height of the rear needle guard is in the position that the rear needle guard is 0.8 mm above the top of the needle when the looper moves to the left as shown in the figure.
- The longitudinal position and inclination of the rear needle guard are in the position that when the right side of the respective needles comes to the blade top of the looper, the top of the needle slightly touches the rear needle guard.

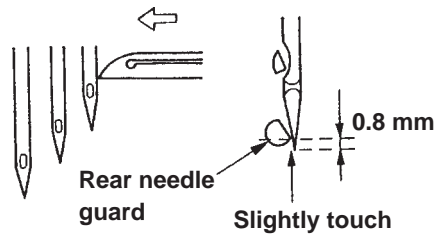
**② Moving needle guard**

- When the looper advances, the clearance between the needle and the moving needle guard is 0.05 to 0.13 mm.

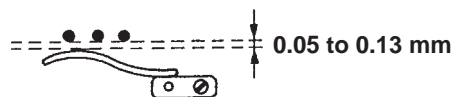

Adjustment Procedures

Results of Improper Adjustment

- Loosen the screw ⑧ and adjust the height and inclination of the rear needle guard ⑨. Loosen the screw ⑩ and adjust the longitudinal position of the rear needle guard ⑨.

(Caution) Check that the rear needle guard does not break the loop of the needle thread by touching the groove of the needle.

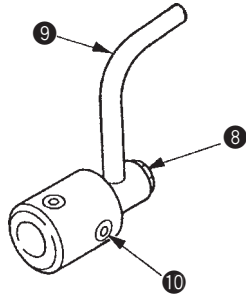

- Loosen the screw ⑪ and adjust the clearance between the moving needle guard ⑫ and the needle.

(Caution) Check that the needle is never caught between the moving needle guard and rear needle guard in any case.

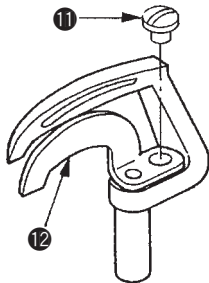

Standard Adjustment

8) Position of the feed dog

- The clearance of the left/right sides of the feed dog should be equal in the slots of the throat plate.
- At the maximum travel, the clearance of the main feed dog and differential feed dog is equal to $A = A'$, $B = B'$.
- The height of the feed dog is 1.1 mm at the top of their stroke.
- The tilt of the feed dog is parallel to the throat plate when the needle bar is at the highest position.

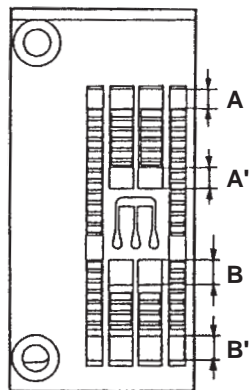

Adjustment Procedures

Open the cover located at the rear side of the needle entry.

- Adjust the longitudinal position of the main feed dog after loosening the nut **13** and rotating the eccentric nut **14**.
- Adjust the longitudinal position of the differential feed dog after loosening the nut **15** and rotating the eccentric nut **16**.

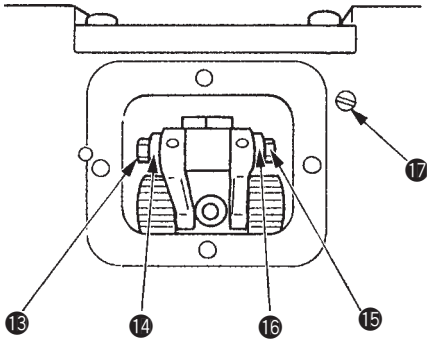

- Adjust the inclination of the feed dog after loosening the screw **17** and rotating the eccentric shaft inside with a slit-screwdriver through the hole **18**.

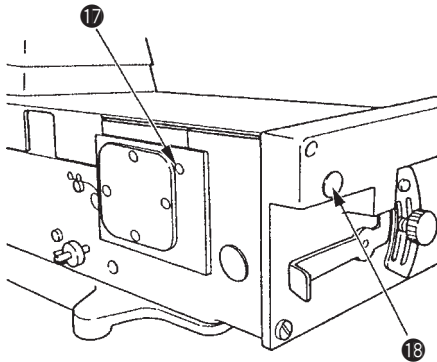

- Loosen the screw **19** and adjust the height of the main feed dog **20**.
- Loosen the screw **21** and adjust the height of the differential feed dog **22**.

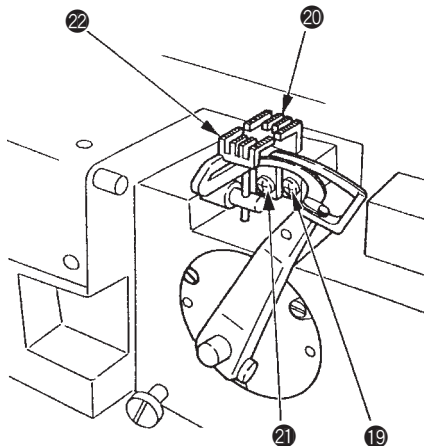

Results of Improper Adjustment

- If the left/right positions of the feed dog are incorrect, the left/right sides and the throat plate will wear out.
- Heating and abnormal noise will be produced.
- The feed components will wear out early. And, the looseness, bending and abnormal noise will be produced.
- If the inclination of the feed dog is raised toward you, starting of the workpiece will be affected.
- If the inclination of the feed dog is lowered toward you, it may cause the irregular stitching and puckering.
- If the position of the feed dog is high, it causes the return feed, skip stitching and defective chain-off.
- If the main feed dog, differential feed dog and throat plate come in contact each other, it will cause the breakage.
- If the position of the feed dog is low, the stitch length becomes short when the sewing is finished.

Standard Adjustment

9) Spreader

① Timing

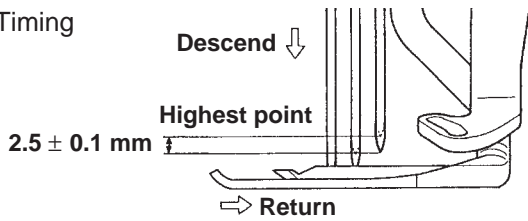

Just when the needle descends 2.5 mm from the highest point of the needle bar, the spreader begins to return from its extreme left position.

② Stroke

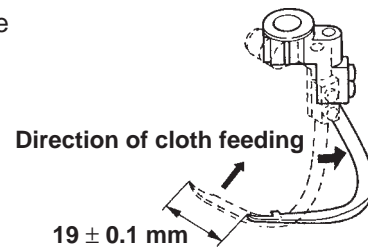

③ Position of spreader

- The height is 11.5 ± 0.5 mm. (4.8 mm or less needle gauge)
(11.1 ± 0.5 mm for 5.6 mm and 6.4 mm gauges)
- When the spreader is in the extreme left position, the distance between the center of the left needle and the top blade of the spreader is 5.5 ± 0.1 mm.
- When the spreader returns to the right, the clearance between the spreader and the left needle is 0.3 to 0.5 mm.

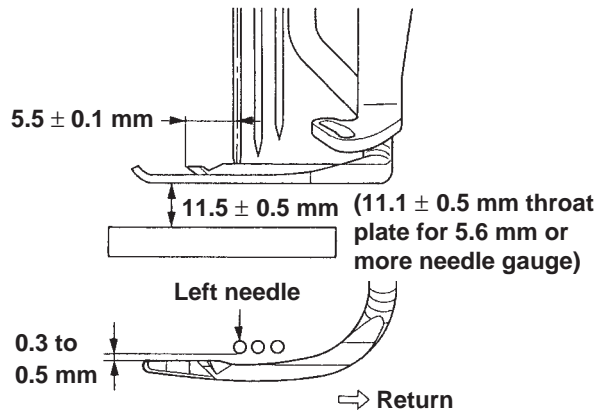

④ Fixing spreader thread guide

- When the spreader is in the extreme right position, the top blade of the spreader should be between left side and middle of the spreader thread guide groove.
- The height is 0.8 to 1.2 mm from the surface of the spreader.

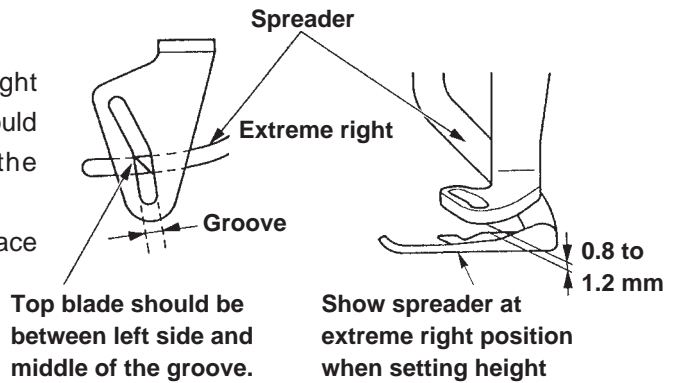

⑤ Needle clamp spreader thread guide

- When the needle bar is in the lowest position, the clearance between the needle clamp spreader thread guide and the upper face of the fixing spreader thread guide is 4 ± 0.5 mm.
- The center of the hole of the thread guide aligns with the left side of the fixing spreader thread guide groove.

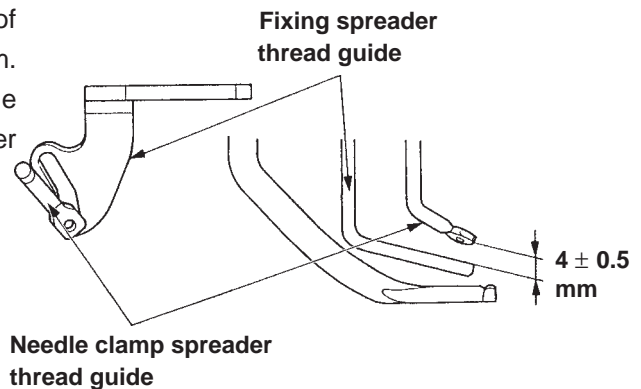

Adjustment Procedures

- Adjust the timing by loosening screw 30 of the spreader eccentric cam 29 and rotate the spreader eccentric cam 29.
- Adjust the stroke by loosening the nut 31 and move back and forth. If it is moved toward you, the stroke becomes small, and to the back it becomes large.
- Adjust the height of the spreader by loosening the screw 33 and moving the spreader 32 up and down.
- Adjust the clearance between the spreader and left needle by loosening the screw 33 and move the spreader 32 back and forth.
- Adjust the extreme left position by loosening the screw 34 and move the spreader 32 to the left and right.

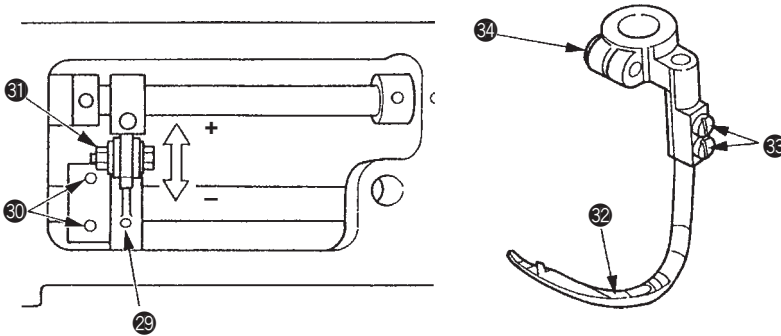

Adjust the fixing spreader thread guide 35 by loosening the screw 36.

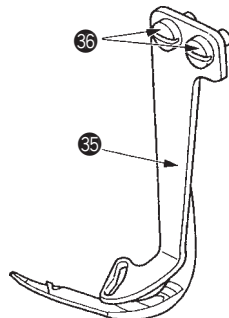

- Adjust the needle clamp spreader thread guide 37 by loosening the screw 38.

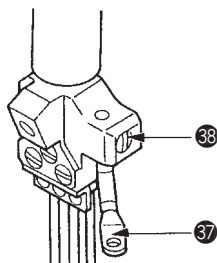

Results of Improper Adjustment

- If the timing is too advanced, the needle does not catch the covering thread when it descends. This is likely to cause the skipping stitch. On the contrary, if the timing is too retarded, the right needle is likely to break as the resistance when the covering thread is pulled from the spreader becomes large.
- If the movement amount of the spreader is not set right, it will cause skip stitching of the top covering thread.
- If the height of the spreader is not set right, it will cause skip stitching of the top covering thread.
- If the clearance between the spreader and needle is small, it will cause the needle breakage. If it is large, it will cause skip stitching of the top covering thread.
- If the protruding amount of the spreader is large, it will cause uneven stitching of the top covering thread. If it is small, it will cause skip stitching of the top covering thread.
- If the height of the fixed spreader thread guide is set as high as 4 mm, the top covering performance by the spun thread is improved. But, defective looping may occur when other threads are used.
- If the position of the fixed spreader thread guide is not correct, it will cause skip stitching of the top covering thread.
- If the position of the needle clamp spreader thread guide is not correct, it will cause skip stitching of the top covering thread.

Standard Adjustment

10) Loper thread cam

① Timing

- When the looper thread is pulled from the highest point of the looper thread cam, the top point of the left needle aligns with the lower face of the looper.

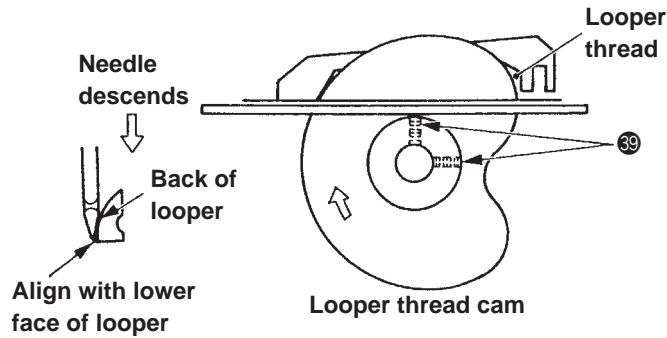

② Position of looper thread guide plate and looper thread cam pawl wire

- The height of the looper thread guide plate is 1.6 mm from the lowest part of the looper cam to the upper part of the looper thread guide plate.
- The rear side of the looper thread cam pawl touches the wire, and its front side is 9.6 mm above the upper face of the wire at the highest place of the inside.
- The looper thread cam pawl and wire are to be positioned in the center of the looper thread cam plate.

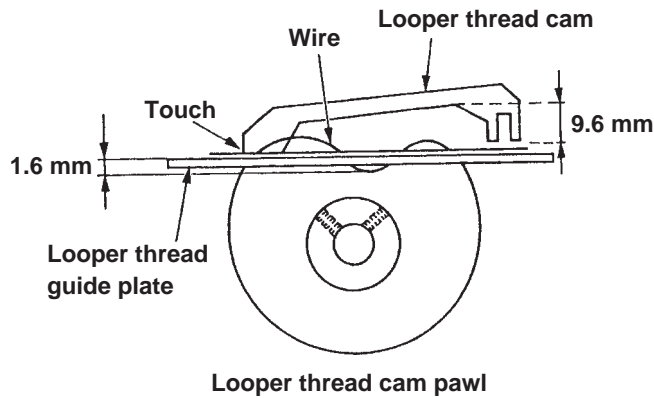

③ Position of thread guide and auxiliary thread tension

- The position of the thread guide is to be set at the position that the looper thread just becomes tight when the looper is in the extreme left.
- Adjust the tension of the auxiliary thread tension to make as low as the thread is just stabilized.

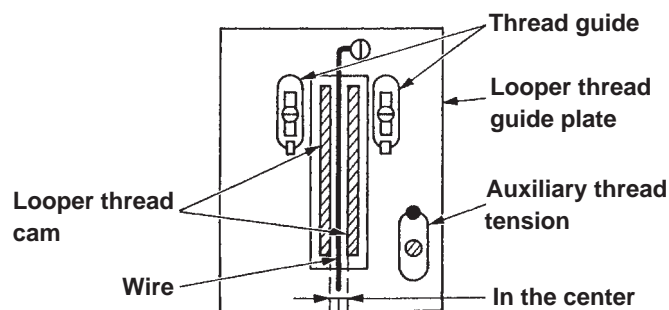

Adjustment Procedures

- Adjust the timing of the looper thread cam by loosening the two screws 39.
- Adjust the height of the looper thread guide plate by loosening the screw 40 and move the looper thread guide plate 41 up and down.
Adjust the looper thread cam pawl by loosening the screw 42 and move the looper thread cam pawl 43 up and down.
Adjust the lateral relation of the looper thread guide plate by loosening the screw 44 and move the looper thread guide plate 41 to the left and right.

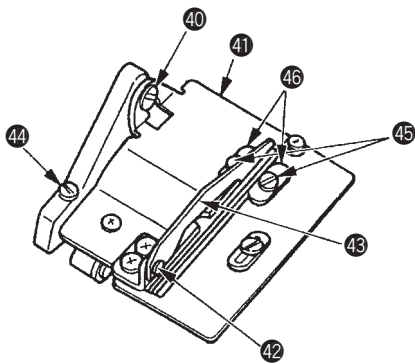

(Caution) Use a 3/32" hexagonal wrench for the screw 39.

- Adjust the position of the thread guide by loosening the two screws 45 and move the thread guide 46 (2 pcs.) up and down.

Results of Improper Adjustment

- If the timing of the looper thread cam is too advanced, the skip stitching on the back of the looper will occur. If it is too retarded, the tightening of the thread will be inferior.
- If the clearance between the looper thread cam pawl and the wire is large, the looper thread suddenly slackens and skip stitching on the back side will occur.
- If the looper thread cam is not in the center, the cam will be damaged.

- If the thread guide is raised, the looper thread after sewing will be slack.
- If the thread guide is lowered, the looper thread after sewing will be tight.

Standard Adjustment**11) Position of the presser bar**

The clearance between the presser bar bracket and the presser bar bushing is 0.8 mm when the feed dog is under the throat plate and the bottom face of the presser foot touches the upper face of the throat plate at the time that the needle bar is in the lowest point.

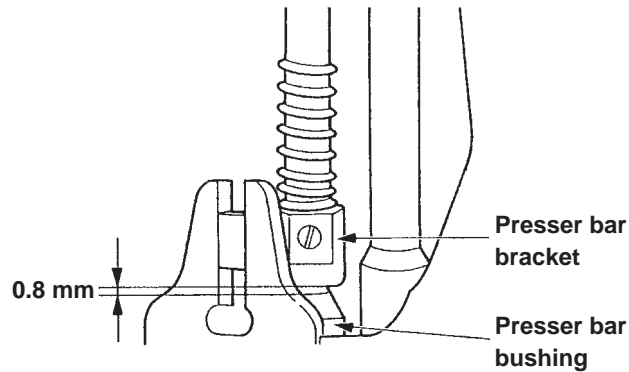
**12) Position of the needle thread tension release (without thread trimmer)**

When the presser foot is raised by 3 mm, the thread tension opening pawl **Ⓒ** touches the thread tension **Ⓓ** and when the presser foot is in the highest position, the thread tension disc opens and there is no tension on the thread.

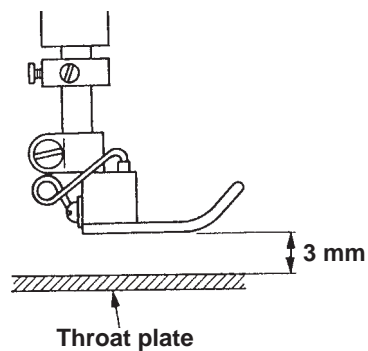

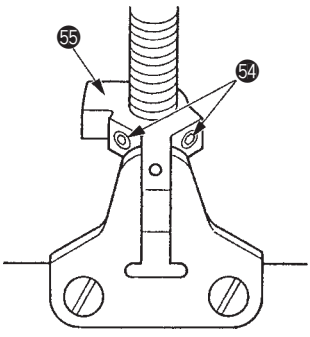
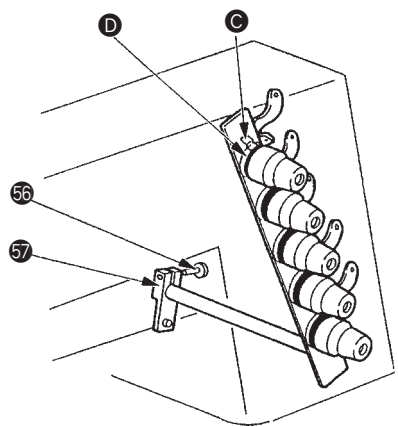
Adjustment Procedures	Results of Improper Adjustment
<p data-bbox="178 264 935 331">○ Adjust by loosening the two screws 54 and move the presser bar bracket 55 up and down.</p> 	<ul style="list-style-type: none"> <li data-bbox="997 264 1412 492">○ If the clearance between the presser bar bracket and the presser bar bushing is small, the bottom face of the presser foot can not contact tightly to the throat plate. <li data-bbox="997 504 1412 616">○ If the clearance is large, the lifting amount of the presser foot will be reduced.
<p data-bbox="178 1193 906 1227">○ Adjust by loosening the screw 56 and move the bracket 57.</p> 	

Standard Adjustment

13) Position and height of the presser foot

- ① Adjust the position of the presser foot so that the needles enter the center of the needle entry holes in the presser foot on condition that the presser foot is set correct to the presser bar.
- ② Adjust the height of the presser foot so that when the needle bar is in its highest point, the needle point does not come out from the lower face of the presser foot.

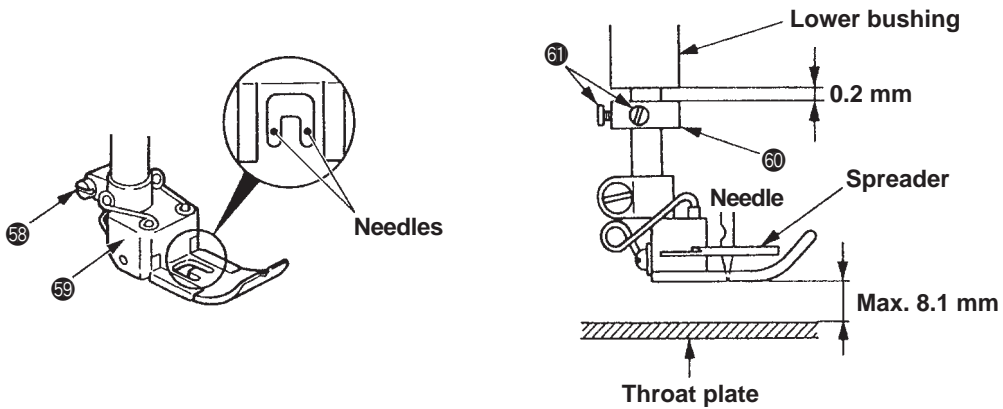

14) Position of the thread guide

- ① Middle thread guide and thread guide holder

	l		
	Left needle thread	Middle needle thread	Right needle thread
Spun thread	27 mm	25 mm	23 mm
Cotton thread	27 mm	25 mm	23 mm
Wooly nylon thread	27 mm	25 mm	23 mm
Tetoron thread	27 mm	25 mm	23 mm

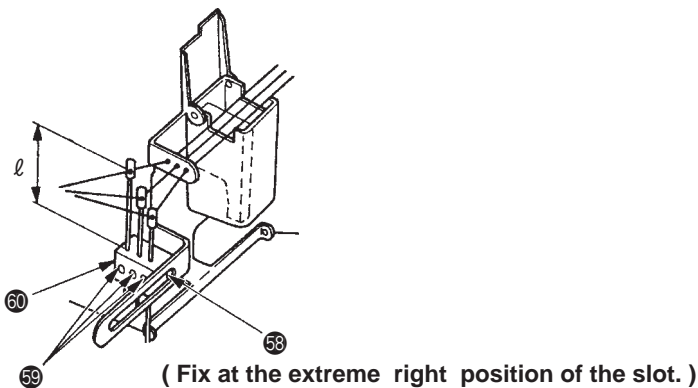

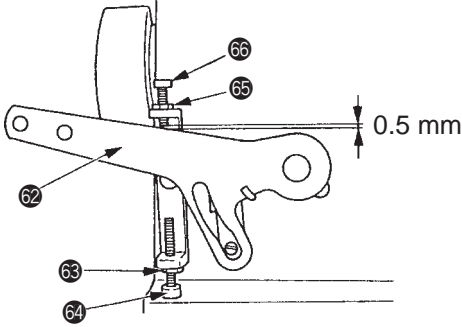
Adjustment Procedures	Results of Improper Adjustment
<p>○ Adjust the position by loosening the screw 58 and move the presser foot 59 to the left and right.</p> <p>○ Adjust the height by loosening the nut 63 and rotate the screw 64 and hit it to the lever 62 so that the needle top comes 0.3 mm over from the lower part of the presser foot when the needle is in its highest point. At this time, loosen the two screws 61 and fix the collar 60 so that the clearance between the collar and the lower bushing is 0.2 mm.</p> <p>Adjust by loosening the nut 65 and rotate the screw 66 so that the clearance between the top end of the screw 66 and the lever 62 becomes 0.5 mm on condition that the presser foot descends and rests tightly on the throat plate.</p> 	<ul style="list-style-type: none"> ○ If the position of the presser foot is not correct, it will cause defective and non-straight sewing. ○ If the height of the presser foot is not correct, it will cause breakage of the spreader, the needle scratch on workpiece, defective sewing and the lack of feeding force.
<p>○ Loosen the screw 58 and fix the thread guide attaching base 60 to the extreme right. Loosen the screw 59 and adjust the respective heights <i>l</i> referring to the left table. Make the fine adjustment watching the actual stitching.</p>	<ul style="list-style-type: none"> ○ If it is raised, the needle thread is tightened. ○ If it is lowered, the needle thread slackens. ○ The tightened stitches of the right needle and left needle can be simply slackened if the thread guide holder is moved to the left.

Standard Adjustment

② Needle bar needle thread release

- When the loop of the needle thread is not easily formed, raise the needle thread release as shown in the figure at the time of the lowest point of the needle bar.

Lowest point of needle bar

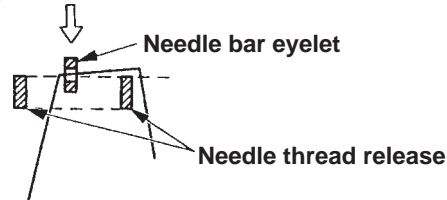

- If the needle thread is a cotton thread, raise the right needle thread release so that the right needle thread only touches at the time of the lowest point of the needle bar.

Lowest point of needle bar

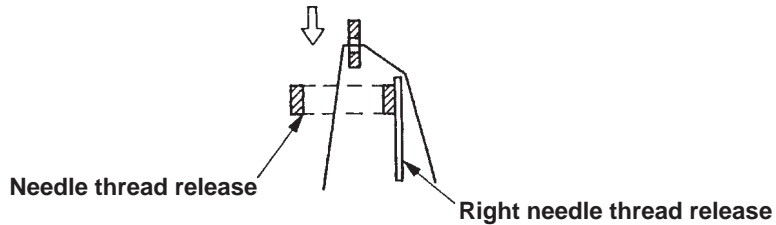

- If the needle thread is a spun thread, lower the needle thread release so that the needle thread does not touch it.

Lowest point of needle bar

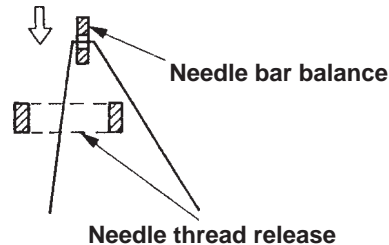

③ Spreader balance thread guide

When the spreader moved to the extreme left position, it should be positioned that the top covering thread does not slacken and the spreader does not pull out the thread.

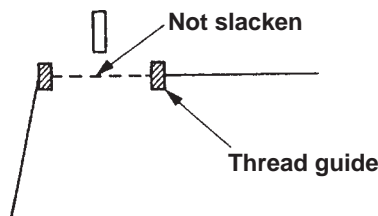

④ Needle thread nipper

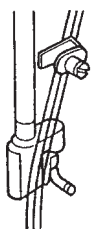

For general thread and materials, perform sewing making thread free without using nipper.

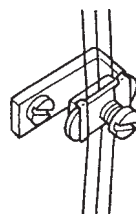

Pass needle thread through nipper when needle thread loop is not well shaped with stretchy thread or the like.

Adjustment Procedures

- Loosen screw 61 and adjust by moving the needle thread release 62 up and down.
- Loosen screw 63 and adjust by moving the right needle thread release 64 up and down.

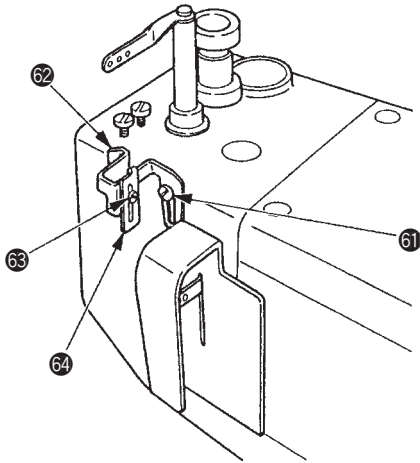

- Loosen screw 65 and adjust by moving the thread guide 66 up and down.

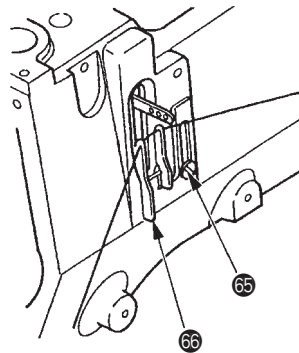

Results of Improper Adjustment

- If it is raised, the loop of the needle thread becomes large.
- If it is lowered, the loop of the needle thread becomes small.
- If the loop is not formed (the loop is too small) and skip stitching occurs, raise the needle thread release.
- If the loop is excessively formed (the loop is too large) and the skip stitching occurs, lower the needle thread release.

- If it is raised, the thread slackens.
- If it is lowered, the thread tightens.
- Use of the nipper for the threads used
Not used for cotton thread and tetoron thread.
Used for wooly nylon thread and spun thread (stretching thread).
- Use of the nipper for the cloth used
Not used for general light-weight jersey, knit and cloth.
Used for heavy-weight jersy, knit and cloth.

(2) Thread trimmer device (MF)

Standard Adjustment

1) Adjustment of the thread trimmer device

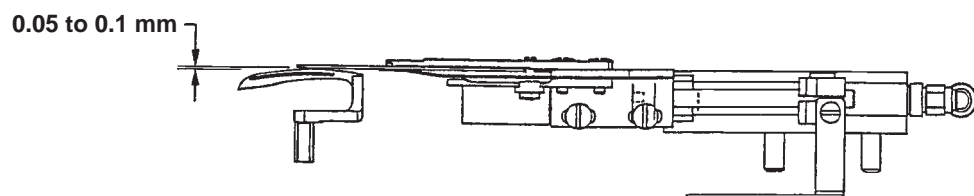
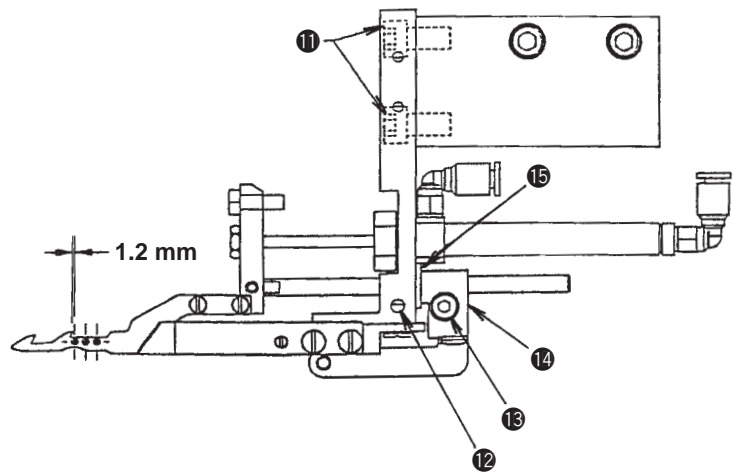
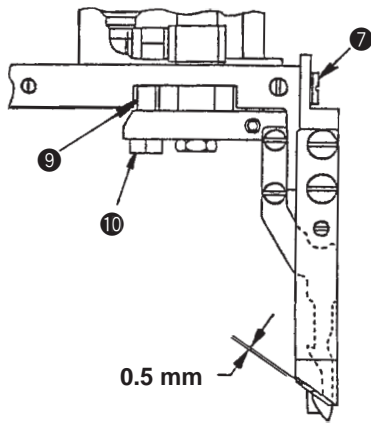
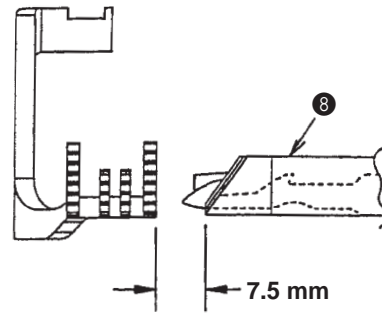
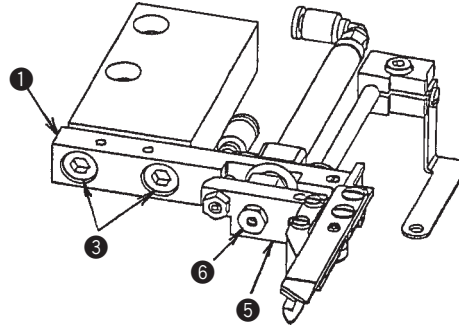
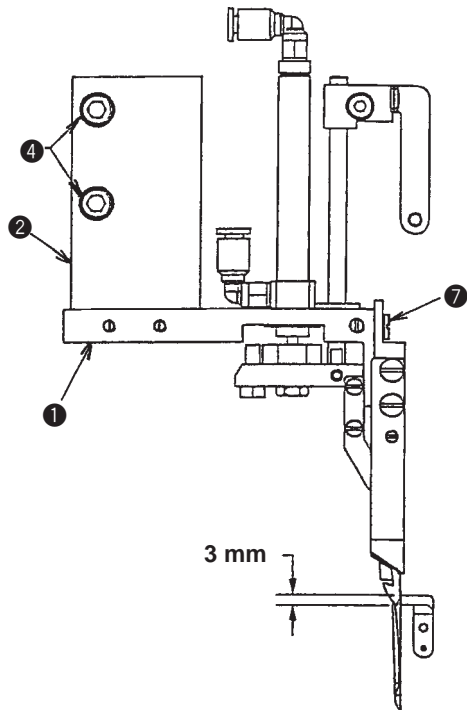

Adjustment Procedures	Results of Improper Adjustment
<ul style="list-style-type: none"> ○ Loosen screws ③ to such an extent that bracket ① in terms of support ② moves. ○ Align engraved marker dot on the frame with that on the hand pulley when needle is at its upper dead point, and perform all adjustments. ○ Install the thread trimmer device on the sewing machine with screws ④, adjust so that the top end of lower knife comes at the position of 3 mm from the right-hand side of the base of looper. As shown in the figure on the left-hand side, securely tighten screws ④ so that the top end of lower knife comes flush at the center of the upper section of the looper. <p>(Caution) When the position of the air cylinder is not set right, make sure that the top surface of bracket ① is flush with that of ⑤, and fix the cylinder with screw ⑥. By so doing, the upper knife can be kept flush at the time of thread trimming.</p> <ul style="list-style-type: none"> ○ Loosen screw ⑦, and adjust upper knife ⑧ to the position of 7.5 mm from the right edge of feed dog. At this time, make sure with screw ⑦ that the vertical pressure is not applied to the lower knife, and adjust by eye observation so that both upper and lower knives are flush with each other. ○ Adjust so that upper knife ⑧ overlaps with the lower knife by 0.5 mm at the waiting position. At this time, determine the position with screw ⑨ and fix with nut ⑩. ○ Temporarily tighten screws ⑪, stretch the lower knife over the looper, and set the height of the knife to 0.05 mm to 0.1 mm at the upper section of the looper. Adjust the clearance between the knife and looper with screw ⑫ and securely tighten screws ⑪. ○ Adjust so that the blade section for needle thread comes to the position of 1.2 mm from the left needle when the lower knife is operating. To adjust, loosen screw ⑬ once, determine the positions of stopper ⑭ and washer ⑮, and tighten screw ⑬. 	

Standard Adjustment

2) Thread tension release (Looper thread trimmer device)

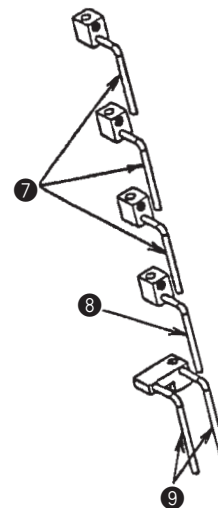
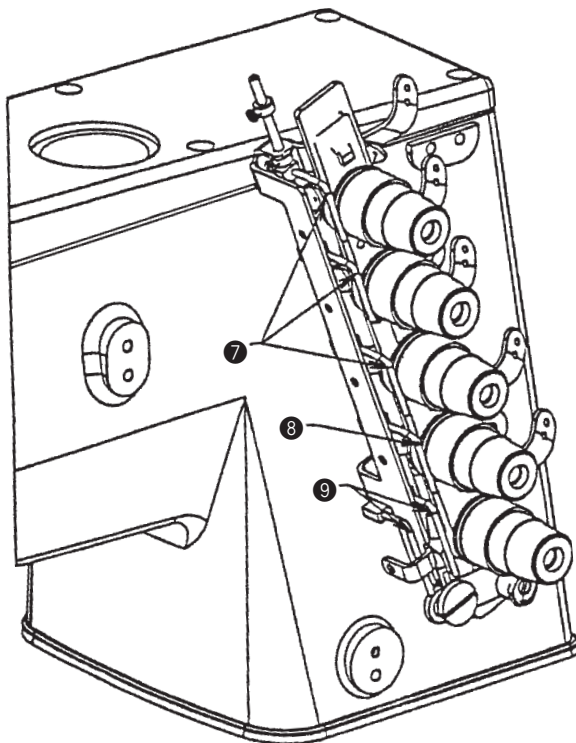
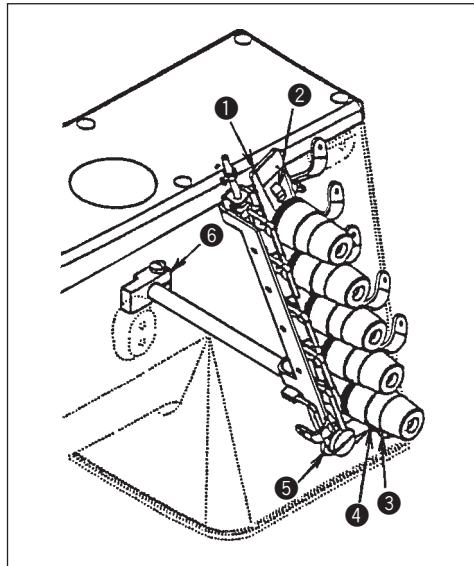

Adjustment Procedures	Results of Improper Adjustment
<ul style="list-style-type: none"> ○ Set tongue ② of thread tension disk separating plate to such a near position where the tongue hardly comes in contact with thread tension disks ①. Thread tension disk ① starts floating immediately after the start of thread trimming. ○ Adjust so that the thread tension disk separating plate can move smoothly and freely among thread tension disks ①. Thread trimming mechanism and thread tension release mechanism are interlocked. ○ Loosen screw ③ and turn eccentric shaft ④ located in the rear of screw ③ to set lever ⑤. ○ Loosen screw ③ again, and make sure that there is no interference in any place. ○ Adjust thread tension release lever ⑥ so that thread is released and the separating plate works smoothly. Thread tension release is simultaneously performed with the start of thread trimmer device. ○ Adjust the length of remaining needle thread after thread trimming with thread tension release pins ⑦ of needle thread. ○ Adjust the shortest length of remaining thread with thread tension release pins ⑦ so that the next stitches can be formed within one to two stitches. ○ Adjust thread tension release pin ⑧ for top covering thread so that spreader thread (top covering thread) is securely hauled at the time of thread trimming and the next stitch can be formed from the first stitch. ○ Part ⑨ is for looper thread and securely hauls the looper thread at the time of thread trimming. <p>(Caution) Move downward thread tension release pins ⑦ to haul thread longer and upward thread tension release pins ⑦ to shorten the length of remaining thread.</p>	

(3) MFC

Standard Adjustment

1) Timing relation between the needle and the feed

First screw **A** in operating direction on double eccentric **1** of feed assembly must be straight up, when the needle bar is at top of stroke.

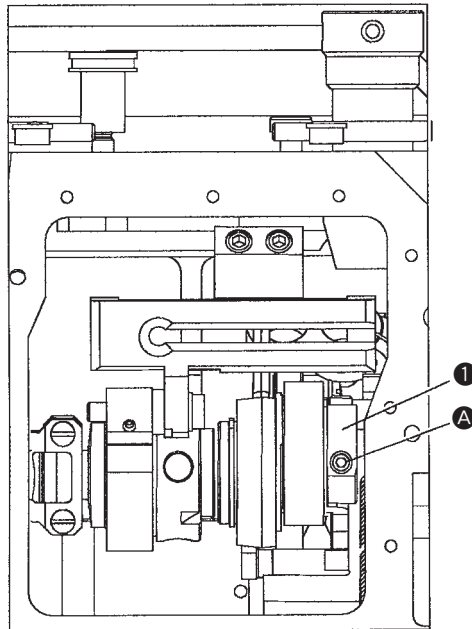

2) Adjusting the timing of the needle bar and looper (Synchronization) : Without gauges

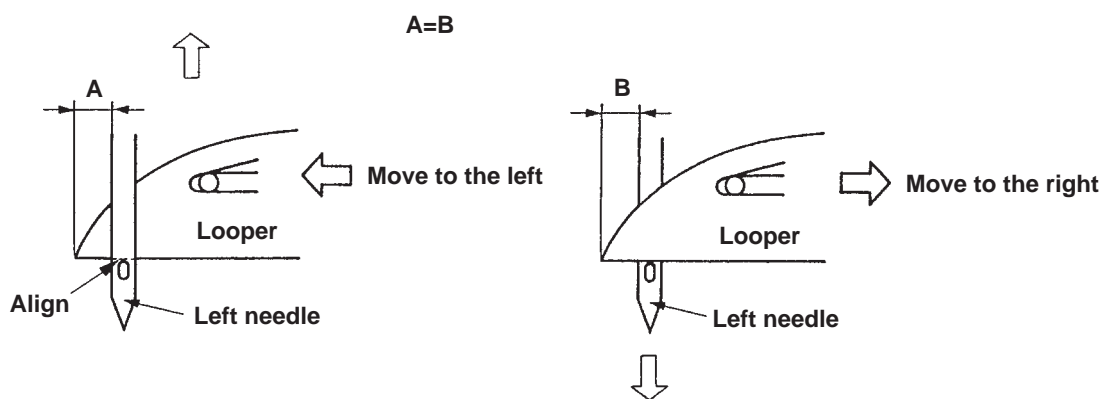

When the blade point of the looper moves to the left in the rear of the needle and to the right in the front of the needle, and the top end of the hole of the left needle aligns with the lower part of the looper, the distance between the left side of the left needle and the blade point of the looper should be equal to the distance A and B.

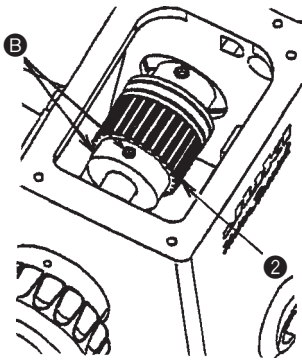
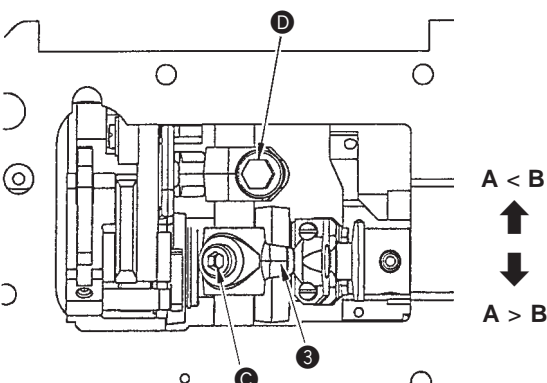
Adjustment Procedures	Results of Improper Adjustment
<ul style="list-style-type: none"> ○ Remove top cover, feed cover, gasket and cloth plate. ○ Loosen screws B of sprocket 2. ○ Rotate lower main shaft in operating direction clockwise, until the first screw A on double eccentric 1 is straight up. ○ Holding pulley to prevent it from turning, rotate handwheel of upper main shaft until needles are at top of their stroke. ○ Adjust the torque of screws B to 5.2 to 5.4 Nm and tighten the screws. ○ Replace top cover, feed cover, gasket and cloth plate.  <p>Note : Earlier machines have 4 screws.</p>	<ul style="list-style-type: none"> ○ Needle breakage ○ Loper fails to catch needle thread.
<ul style="list-style-type: none"> ○ Dimension A : Turn handwheel in operating direction until bottom of looper is even with top of needle eye. ○ Dimension B : Continue turning handwheel in operating direction until bottom of looper is even with top of needle eye when looper is in front of needle. ○ If dimension A is greater than dimension B <ul style="list-style-type: none"> 1) Loosen C in connector 3. 2) Move connector 3 away from connector D. Tighten C. Repeat above steps until dimension A = dimension B. ○ If dimension A less than dimension B <ul style="list-style-type: none"> 1) Loosen screw C in connector 3. 2) Move connector 3 toward D. Tighten C. Repeat above steps until dimension A = dimension B. 	<ul style="list-style-type: none"> ○ If the timing is not set right, it is likely to occur skipping and tangling stitches.

Standard Adjustment

3) Returning amount of the looper

When the looper is at the extreme right position, the distance between the blade point of the looper and the center of the right needle is 4.8 ± 0.1 mm.

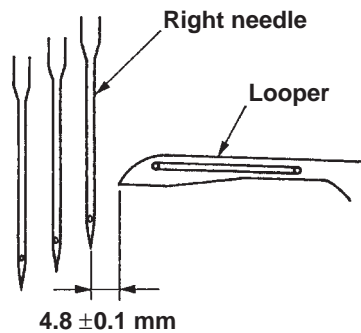
**4) Height of the needle bar**

When the looper moves to the left and the point of the looper comes out from the left side of the left needle by 0.5 mm, the lower part of the looper aligns with the top end of the hole of the left needle.

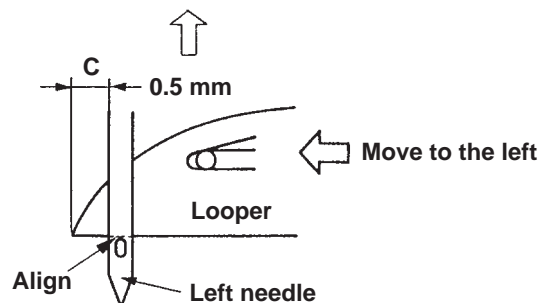

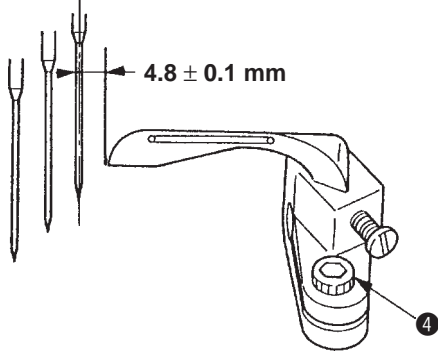
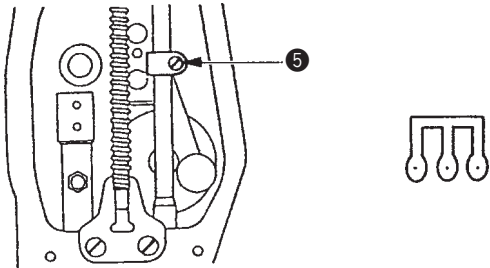
Adjustment Procedures	Results of Improper Adjustment
<p>○ Adjust the returning amount by loosening the looper holder binder screw ④.</p> 	<p>If the returning amount is large, skipping stitch and tangling stitch will occur. And the thickness of the material to be sewn will be reduced. If the returning amount is small, skipping stitch and tangling stitch will occur.</p>
<p>○ Loosen the screw ⑤ of the needle bar binder bracket inside the face cover and adjust the height of the needle bar.</p> <p>(Caution) After the adjustment, check that the direction of the needle clamp is right and that the respective needles enter the center of the holes of the throat plate.</p> 	<p>If the measurement of C is large, skip stitching and thread tangling occur. If the measurement of C is small, skip stitching and thread tangling occur.</p>

Standard Adjustment

5) Position of the needle guard

- ① The height of the rear needle guard is adjusted so that the point of the right needle comes to the 1/2 height of the contact surface of the rear needle guard when the blade point of the looper aligns with the right side of the right needle.
Adjust the pushing amount so that the right needle and the middle needle are slightly pushed, and so that the left needle just comes in contact with the rear needle guard and should not be pushed. (The blade point of the looper should not contact the respective grooves of the all needles.)

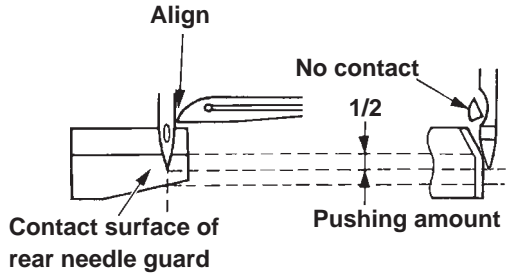

Pushing amount : Slightly push right needle and middle needle. Make the left needle just come in contact with the rear needle guard and do not push it.

- ② The height of the front needle guard is 1.75 ±0.1 mm from the lower part of the looper. The face of the guard position is parallel to all needles having a clearance of 0.25 ±0.1 mm.

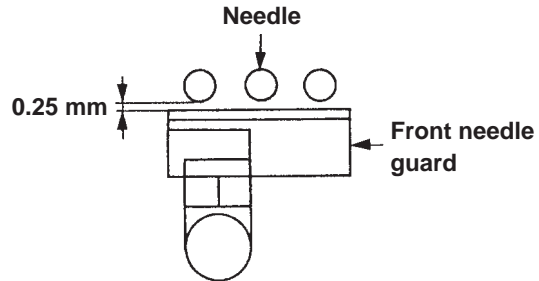
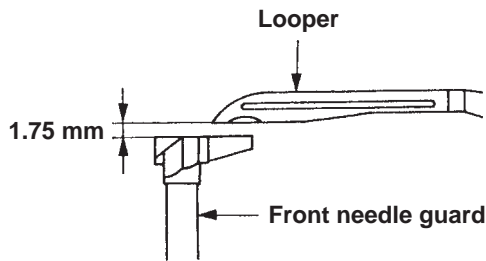

6) Clearance between the looper and needle

Clearance between the blade point of the looper and the grooves of the right and left needles is 0 to 0.05 mm. (Clearance of the middle needle is a little larger.)

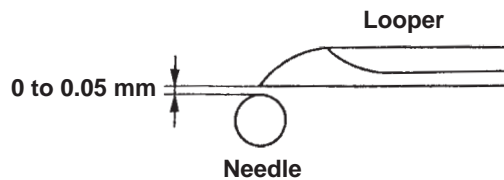
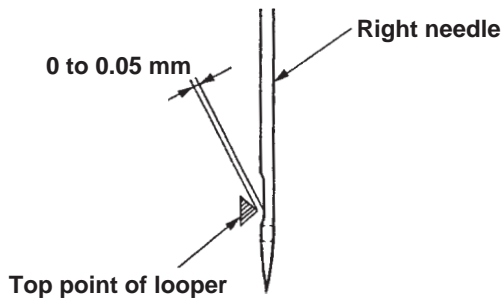

Adjustment Procedures

- Adjust the height of the rear needle guard by loosening the screw 12 and move the rear needle guard 11 up and down. Adjust the pushing amount by loosening the screw 13 and move the rear needle guard back and forth.
- Adjust the height of the front needle guard by loosening the screw 15 and move the front needle guard 14 up and down. Adjust the inclination at the same time. Adjust the clearance for the needle by loosening the screw 16 .

(Caution) Use a 3/32" hexagonal wrench for the screw 13.

Check that there is no looseness on the left/right sides of the rear needle guard when tightening the screw 13.

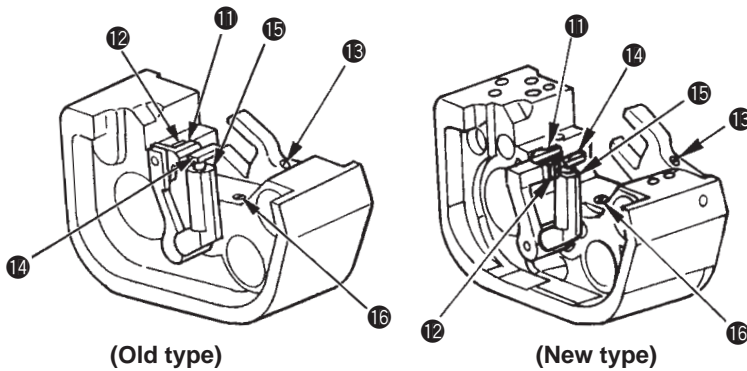

Results of Improper Adjustment

- If the clearance between the rear needle guard and the needle is large, it causes the skipping stitch, the damage of the blade point of the looper and needle breakage.
- If the rear needle guard and the needle hits strongly, it will cause the damage of the needle top.
- If the clearance between the front needle guard and the needle is large, the loop becomes small and the skipping stitch will occur.
- If the front needle guard and the needle hits strongly, the loop becomes large and the skipping stitch, the damage of the needle point and the damage of the blade point of the looper will occur.

- Adjust by loosening the looper base setscrew 4 and move the looper holder back and forth.

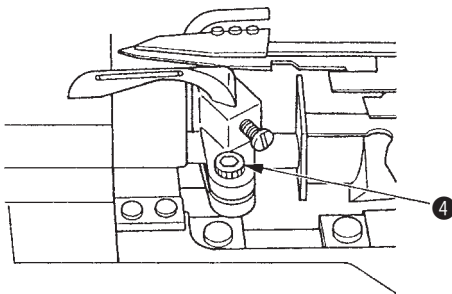

- If the clearance is large, skipping stitch of the needle thread scooping occurs. And the damage of the needle point will occur due to the strong hit on the back of the looper.
- If the clearance is small, the damage of the blade point of the looper and the needle breakage will occur. And, the skipping stitch will occur as the clearance between the back of the looper and the needle becomes large.

Standard Adjustment

7) Adjusting amount of the looper-avoid

- When there is only one adjustment line in the sewing machine, adjust so that the looper path shifting cam is placed 8 mm from the adjustment eccentric line.
(Measurement of 8 mm should be performed on the top surface of the looper path shifting cam.)

New type

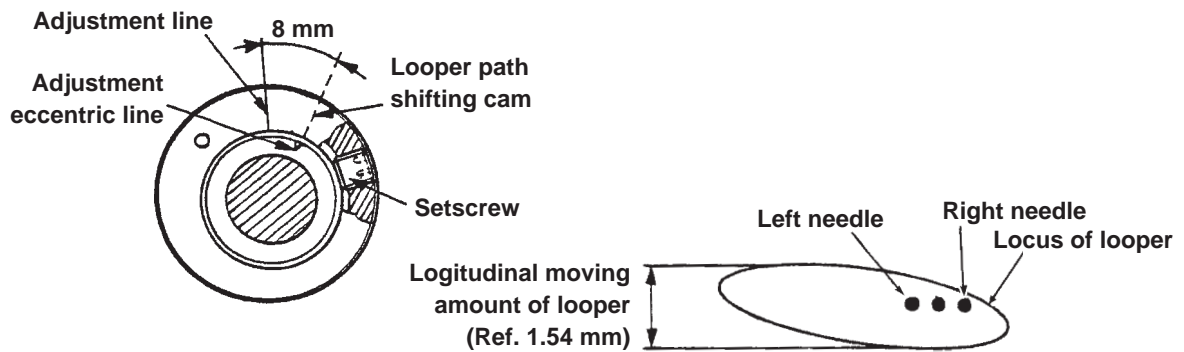

- When the looper moves to the right, the tip of the left needle contacts the back of the looper at the position of 2/3 from the upper side of the looper.

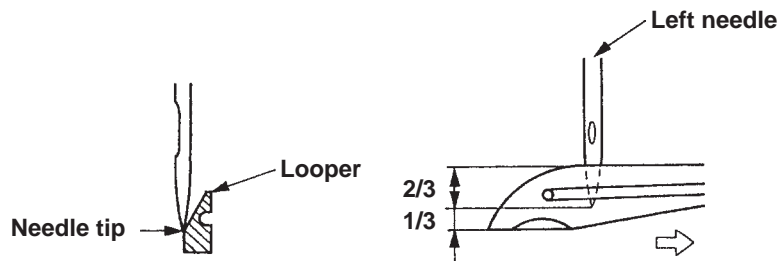

(Adjust when the needle is replaced with an excessively different sized needle. Check that the clearance between the looper and the needle is correct and the needle tip contacts the back of the looper at the position of 2/3 from the upper side of the looper.)

Adjustment Procedures

① Adjustment of looper path

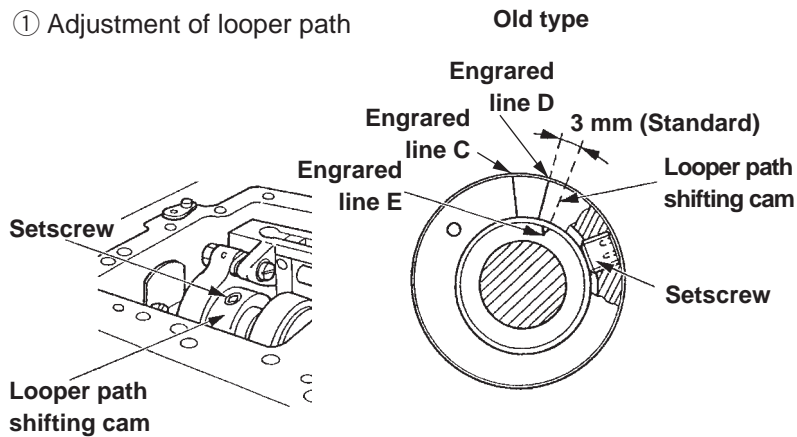

② Adjustment of avoid

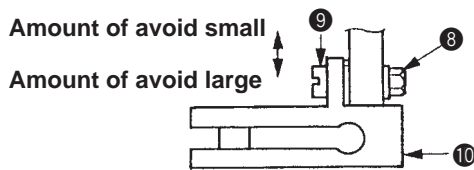

Loosen the screw ⑨ and nut ⑧ of the looper cam guide ⑩. Then move the screw ⑨ back and forth to adjust. (Use a 3/8" spanner for ⑧.)

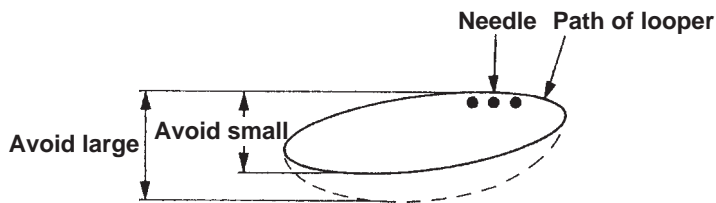

(Caution) After the adjustment, check again the clearance between the blade point of the looper and the groove of the needle.

Use a 1/8" hexagonal wrench for the setscrew ⑥.

Results of Improper Adjustment

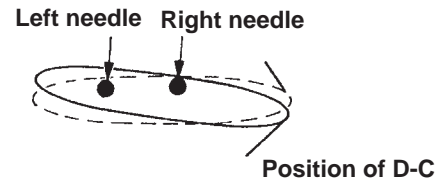

- If the engraved line E is turned more than 3 mm from D, the looper path is left downward. The damage of the blade point of the looper and needle breakage occur.
- If the amount of avoid is large, the clearance between the needle and the back of the looper becomes large. In this case, skipping stitch and tangling stitch occur.
- If the amount of avoid is small, the hitting of the needle and the back of the looper becomes strong. In this case, the damage of the needle top, needle breakage and scratch on the back of the looper occur.

Standard Adjustment

8) Position of the feed dog

- The clearance between the slot on the throat plate and the left/right sides of the feed dog should be equal.
- In the maximum stroke end of the main feed dog and differential feed dog, the clearance should be equal to $A = A'$ and $B = B'$.
- Height of the feed dog is 1.1 mm at the top of their stroke.
- Tilt of the feed dog is parallel to the throat plate when the needle bar is in its highest position.

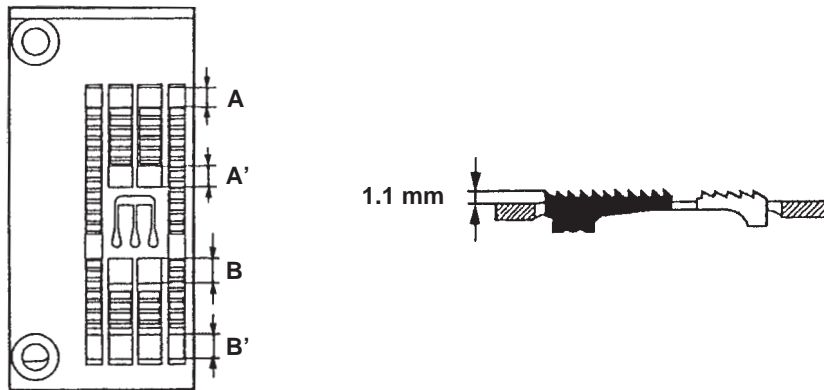

- Adjust so that the throat plate and the main feed dog do not contact each other even if the main feed dog is in its maximum stroke end.

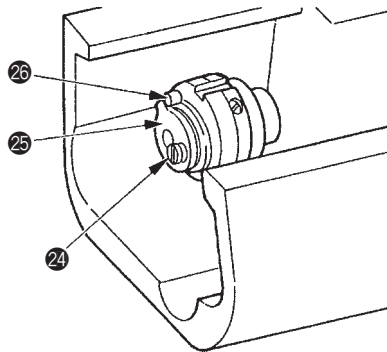

- Adjust so that the throat plate and the differential feed dog do not contact each other even if the stroke is maximized.

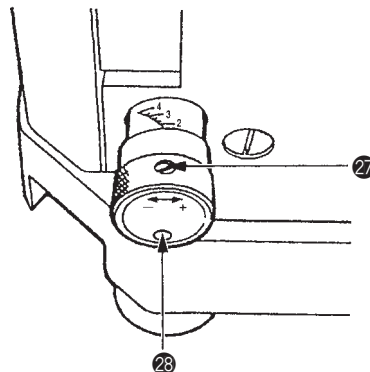

Adjustment Procedures

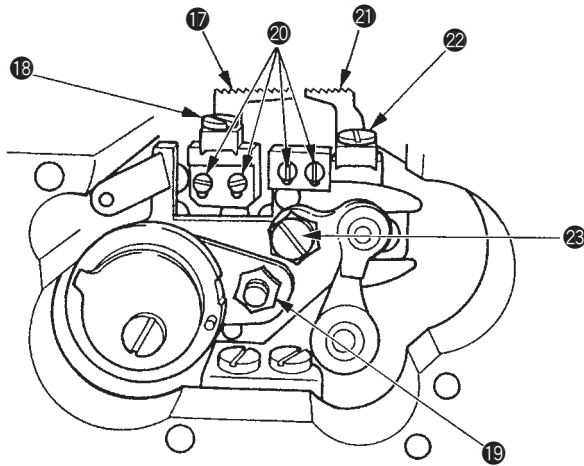

- Loosen screw 18 to adjust the left/right position of the main feed dog 17 .
- Loosen screw 22 to adjust the left/right position of the differential feed dog 21 .
- Loosen screw 19 and move the main feed dog back and forth to adjust the longitudinal position of the main feed dog 17 .
- Loosen screw 23 and rotate the eccentric nut to adjust the longitudinal position of the differential feed dog 21 .
- Loosen screw 20 to adjust the height of the main feed dog 17 and the differential feed dog 21 .
- To adjust the maximum stroke of the main feed dog, loosen screw 24 and rotate spacing stop 25 so that it contacts the pin 26 when the main feed dog has reached its maximum stroke and while the throat plate does not contact the main feed dog.
- To adjust the maximum stroke of the differential feed dog, loosen screw 27 and enter the stopper pin 28 to the end when the differential feed dog has reached its maximum stroke and while the differential feed dog does not contact the throat plate and the front end of the main feed dog.

Results of Improper Adjustment

- If the lateral position of the feed dog is not correct, the left/right sides of the feed dog and the throat plate will wear out. Heating and abnormal noise will be produced. Also, the feed components will wear out quickly and looseness and bending of the components will occur. Also, abnormal noise from the components will be produced.
- If the height of the feed dog is low, the stitch length at the finish of sewing becomes smaller.
- If the height of the feed dog is high, it will cause the return feed, skipping stitch and defective chain-off.
- If the main feed dog, differential feed dog, and throat plate come in contact with each other, it will cause breakage.

Standard Adjustment

9) Spreader

① Timing

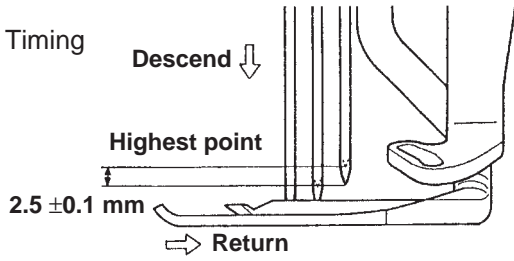

Just when the needle descends 2.5 mm from the highest point of the needle bar, the spreader begins to return from the extreme left position.

② Stroke

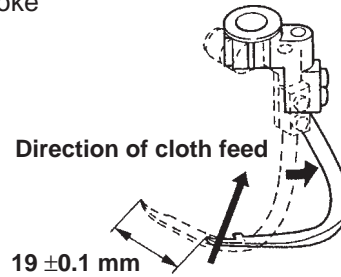

③ Position of spreader

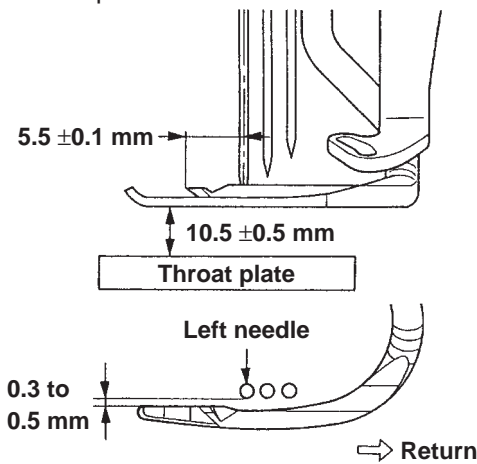

- Height of the presser foot is 10.5 ± 0.5 mm.
- When the spreader is in the extreme left position, the distance between the center of the left needle and the blade point of the spreader is $5.5 \text{ mm} \pm 0.1$ mm.
- When the spreader returns to the right, the clearance between the spreader and the left needle is 0.3 to 0.5 mm.

④ Fixing spreader thread guide

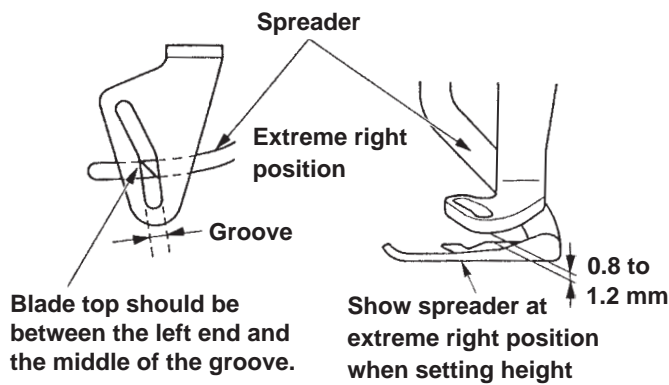

- When the spreader is in the extreme right position, the blade top should be between the left end and the middle of the groove of the fixing spreader thread guide.
- The height is 0.8 to 1.2 mm from the upper face of the spreader.

⑤ Needle clamp spreader thread guide

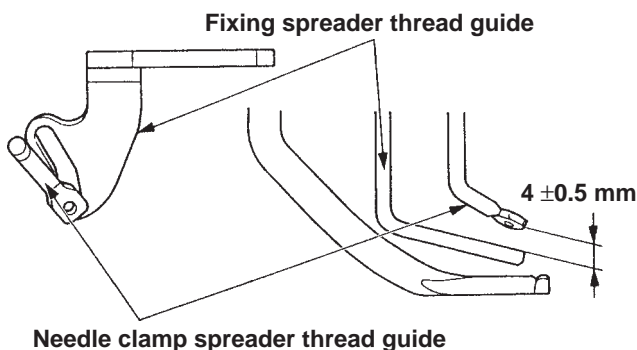

- When the needle bar is in the lowest position, the clearance between the needle clamp spreader thread guide and the upper face of the fixing spreader thread guide is 4 ± 0.5 mm.
- The center of the thread guide hole aligns with the left end of the groove of the fixing spreader thread guide.

Adjustment Procedures

Results of Improper Adjustment

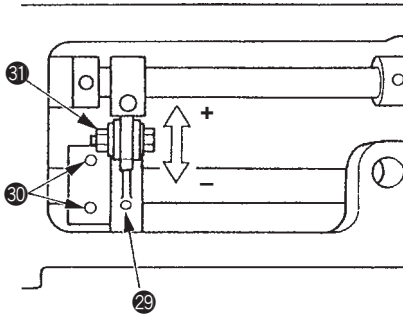

Adjust the timing by loosening the screw 30 of the spreader eccentric cam 29 and rotating the spreader eccentric cam 29 .

Adjust the stroke by loosening the nut 31 and moving it back and forth.

If it is moved toward you, the stroke becomes small. If it is moved to the back, the stroke becomes large.

Adjust the height of the spreader by loosening the screw 33 and move the spreader 32 up and down.

Adjust the clearance between the spreader and the left needle by loosening the screw 33 and moving the spreader 32 back and forth.

Adjust the extreme left position by loosening the screws 34 and move the spreader 32 to the left and right.

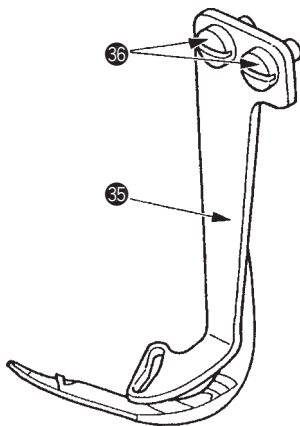
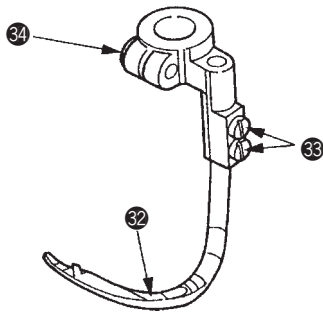

Adjust the fixed spreader thread guide 35 by loosening the screws 36 .

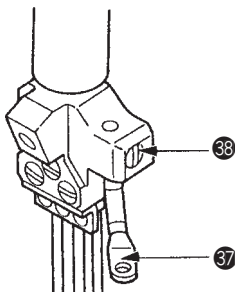

Adjust the needle clamp spreader thread guide 37 by loosening the screw 38 .

- If the timing is too advanced, skipping stitch is likely to occur as when the needle descends, the needle does not catch the covering thread. If the timing is too retarded, the right needle is likely to be broken as the resistance of the covering thread becomes strong when it passes the covering thread looper.
- If the movement amount of the spreader is not set right, skipping stitch of the top covering thread occurs.
- If the height of the spreader is not set right, skipping stitch of the top covering thread occurs.
- If the clearance between the spreader and the needle is small, the needle breaks. If it is large, skipping stitch of the top covering thread occurs.
- If the protruding amount of the spreader is large, uneven stitch of the top covering thread occurs. If it is small, skipping stitch of the top covering thread occurs.
- If the height of the fixed spreader thread guide is set about 4 mm, the performance of the top covering with the spun thread is improved. But, for other threads, it is likely to cause the defective pick-up of the thread.
- If the position of the fixed spreader thread guide is not set right, skipping stitch of the top covering thread occurs.
- If the position of the needle clamp spreader thread guide is not set right, skipping stitch of the top covering thread occurs.

Standard Adjustment

10) Loper thread cam

① Timing of the looper thread cam

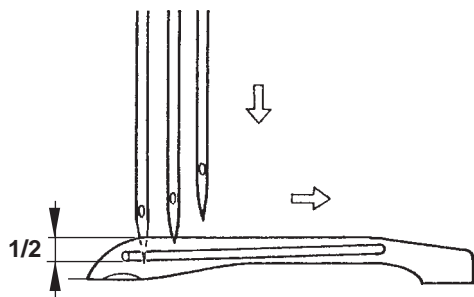

When the needle bar descends and the tip of the left needle aligns with the lower part of the looper, the looper thread can be cast off from the highest point of the looper cam.

② Position of the looper thread cam thread guide

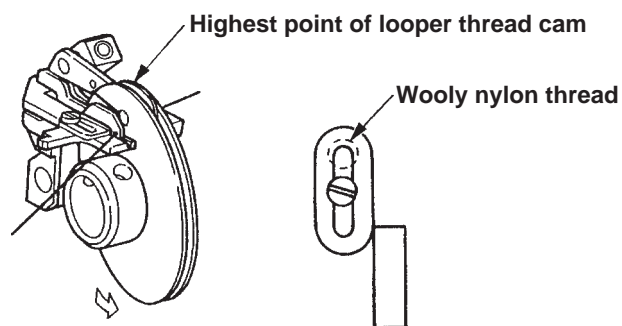

The looper thread cam thread guide is to be set in the center of the slot. (In case of wooly nylon thread, at the upper end of the slot.)

11) Loper thread wrap-up preventing cam (Old type)

① Height of the looper thread thread guide base

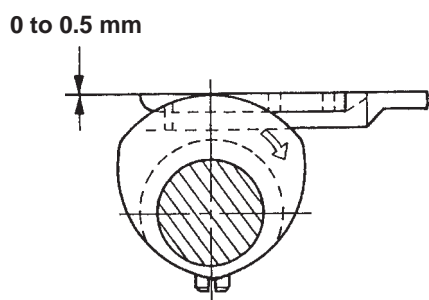

The position is that the highest point of the looper thread tangling preventing cam is 0 to 0.5 mm lower than the upper part of the thread control finger.

②

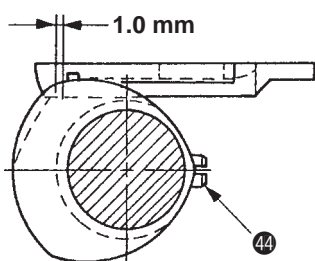

Timing of the looper thread tangling preventing cam and position of the thread control finger. When the looper thread is cast off out of the highest point of the looper thread cam, the horn of the looper thread tangling preventing cam comes 1.0 mm toward you from the hole of the thread guide of the thread control finger.

Adjustment Procedures

Results of Improper Adjustment

Looper thread

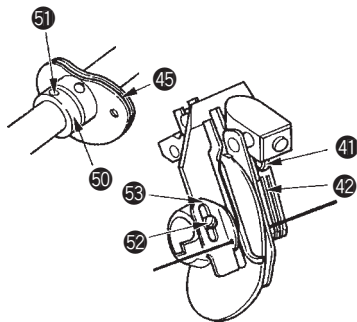
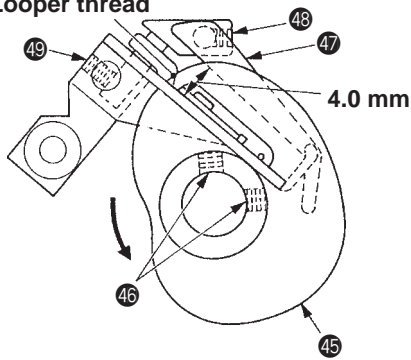

- Timing of the looper thread cam is adjusted by loosening the screw 46 and rotating the looper thread cam 45 .
At this time, set so that the collar 50 contacts 45 . In case of lateral adjustment, loosen the screw 51 of the collar 50 and adjust on condition that the looper thread cam 45 contacts the collar 50 .
- Loosen the screw 48 for the parallel and the screw 49 for the clearance so that the middle latch 47 is parallel to the looper thread guide base and the clearance is 4.0 mm.
- Loosen the screws 52 and 41 , and adjust by moving the left needle thread guide 53 and the thread control finger 42 up and down.

(Caution) Use a 3/32" hexagonal wrench for the screws 46 , 48 and 49 .

- If the timing of the looper thread cam is too advanced, skip stitching on the back of the looper occurs.
If the timing of the looper is too retarded, thread tightening is not well.
- If the looper thread cam is not set in the center, the cam is scratched.
- If the clearance between the middle latch and the looper thread guide base is more than 4 mm, the looper thread suddenly slackens and skip stitching on the back of the looper occurs.
- If the thread guide is raised too high, the looper thread after the sewing is finished becomes tight.
- If the thread guide is lowered too much, the looper thread after the sewing is finished becomes slack.

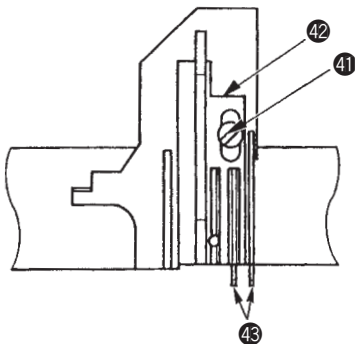
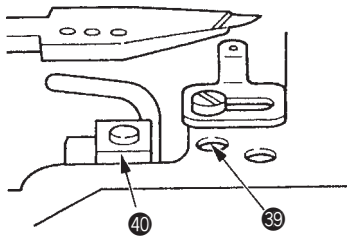

- Adjust the height of the looper thread guide base by loosening the screw 39 and inclining the latch base 40 .
- The looper thread anti-wrap cam 43 comes to the center of the slit of the thread control finger 42 and the horn part of the periphery of the cam aligns with the hole of the thread guide.
Adjust the looper thread tangling preventing cam 43 by loosening the screw 44 .

(Caution) Use a 3/32" hexagonal wrench for the screw 39.

- The looper thread may be cut if the looper thread tangling preventing cam contacts the slot of the thread control guide.
- If the timing of the looper thread anti-wrap cam and the position of the thread guide are not set right, the thread may be entangled.

Standard Adjustment**12) Position of the presser bar**

When the feed dog is under the lower part of the throat plate and the bottom face of the presser foot contacts the upper face of the throat plate at the lowest point of the needle bar, the clearance between the presser bar bracket and the upper end of the presser bar bushing is 0.8 mm.

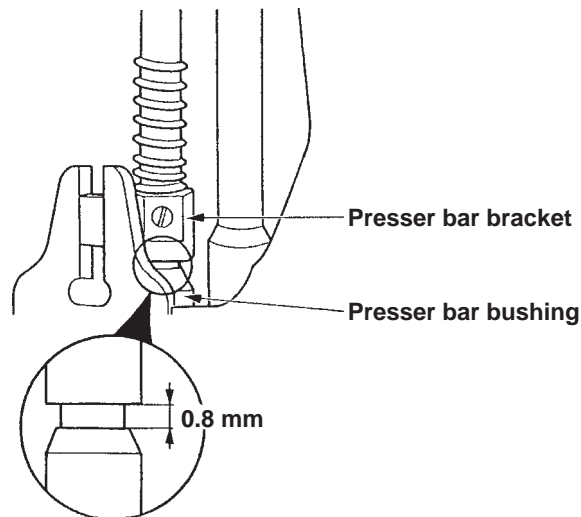
**13) Position of the needle thread tension release (without thread trimmer)**

When the presser foot is raised by 3.0 mm, the thread tension opening pawl **C** contacts the thread tension disc **D**, and when the presser foot is raised at its highest point, the thread tension disc opens and there is no tension on the thread.

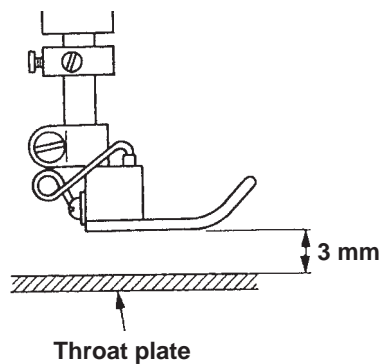

Adjustment Procedures

- Loosen the two screws 54 and adjust the position by moving the presser bar bracket 55 up and down.

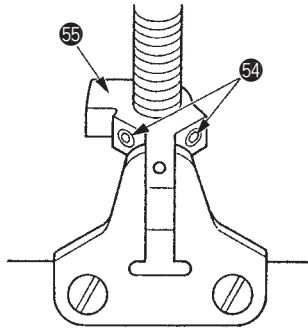

Results of Improper Adjustment

- If the clearance between the presser bar bracket and the presser bar bushing is too small, the bottom face of the presser foot is not closely fitted on the throat plate.
If the clearance is too large, the lifting amount of the presser foot becomes small.

- Loosen screw 56 and adjust by moving the bracket 57 .

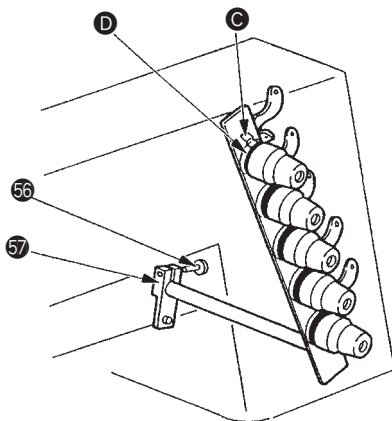

Standard Adjustment

14) Position and height of the presser foot

- ① Adjust the position of the presser foot so that the needles are positioned to enter the centers of the holes of the needle entry of the presser foot on condition that the presser foot is set right to the presser bar.
- ② Adjust the height of the presser foot so that the needle top does not come out from the bottom face of the presser foot when the needle bar is in its highest point.

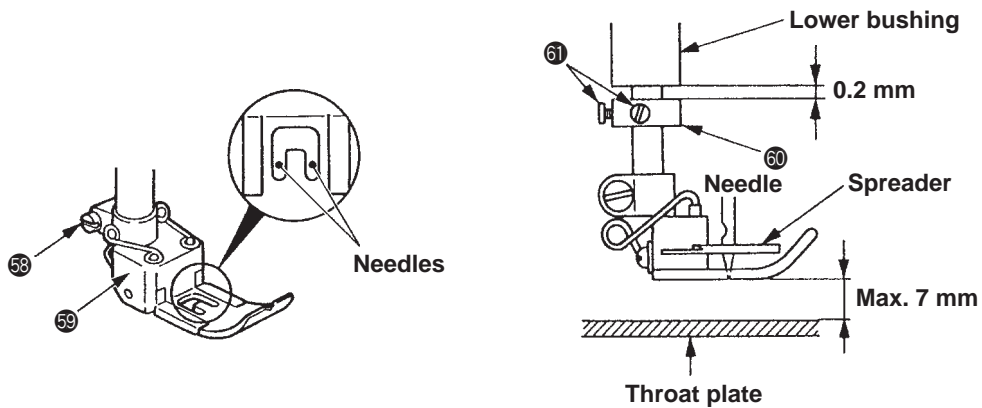

15) Position of the thread guide

- ① Middle thread guide and thread guide attaching base

	<i>l</i>		
	Left needle thread	Middle needle thread	Right needle thread
Spun thread	16 mm	14.5 mm	13 mm
Cotton thread	16 mm	21 mm	21 mm
Wooly nylon thread	16 mm	21 mm	21 mm
Tetoron thread	16 mm	21 mm	21 mm

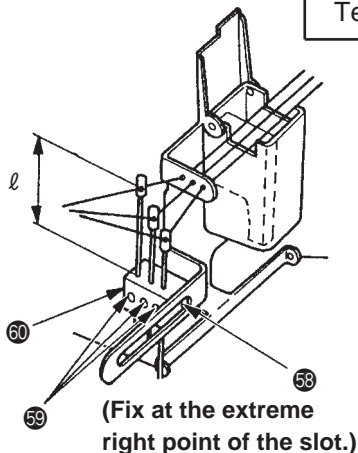

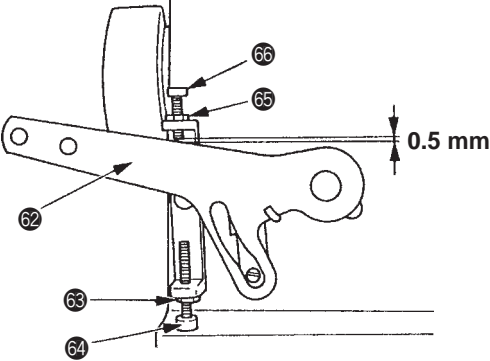
Adjustment Procedures	Results of Improper Adjustment
<ul style="list-style-type: none"> ○ Adjust the position by loosening the screw 58 and move the presser foot 59 to the left and right. ○ Adjust the height by loosening the nut 63 and rotate the screw 64 and hit it to the lever 62 so that the needle top comes 0.3 mm over from the lower part of the presser foot when the needle is in its highest point. At this time, loosen the two screws 61 and fix the collar 60 so that the clearance between the collar and the lower bushing is 0.2 mm. Adjust by loosening the nut 65 and rotate the screw 66 so that the clearance between the top end of the screw 66 and the lever 62 becomes 0.5 mm on condition that the presser foot descends and rests tightly on the throat plate. 	<ul style="list-style-type: none"> ○ If the position of the presser foot is not correct, it will cause defective and non-straight sewing. ○ If the height of the presser foot is not correct, it will cause breakage of the spreader, the needle scratch on workpiece, defective sewing and the lack of feeding force.
<ul style="list-style-type: none"> ○ Loosen the screw 58 and fix the thread guide attaching base 60 to the extreme right. Loosen the screw 59 and adjust the respective heights “ℓ” referring to the left table. Make the fine adjustment watching the actual stitching. 	<ul style="list-style-type: none"> ○ If it is raised, the needle thread is tightened. ○ If it is lowered, the needle thread slackens. ○ The tightened stitches of the right needle and left needle can be simply slackened if the thread guide attaching base is moved to the left.

Standard Adjustment

② Needle bar needle thread release

Lowest point of needle bar

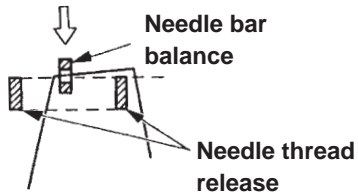

- When the loop of the needle thread is not easily formed, raise the needle thread release as shown in the left figure at the time of the lowest point of the needle bar.

Lowest point of needle bar

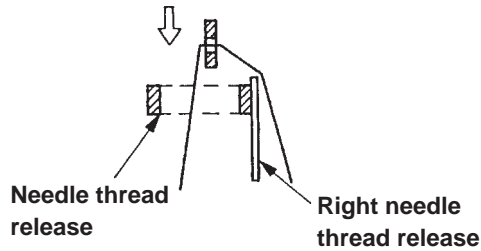

- If the needle thread is a cotton thread, raise the right needle thread release so that the right needle thread only touches at the time of the lowest point of the needle bar.

Lowest point of needle bar

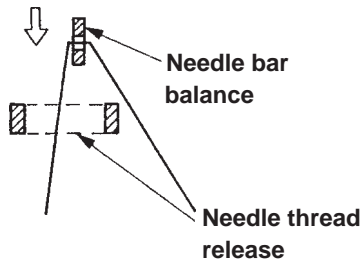

- If the needle thread is a spun thread, lower the needle thread release so that the needle thread does not touch it.

③ Spreader balance thread guide

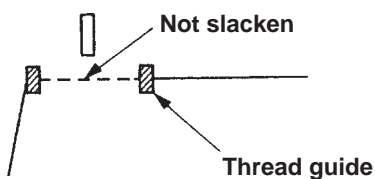

When the spreader moved to the extreme left position, it should be positioned that the top cover thread does not slacken and the spreader does not pull out the thread.

④ Needle thread nipper

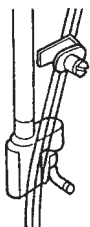

For general thread and materials, perform sewing making thread free without using nipper.

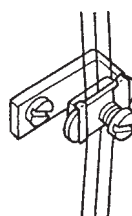

Pass needle thread through nipper when needle thread loop is not well shaped with stretchy thread or the like.

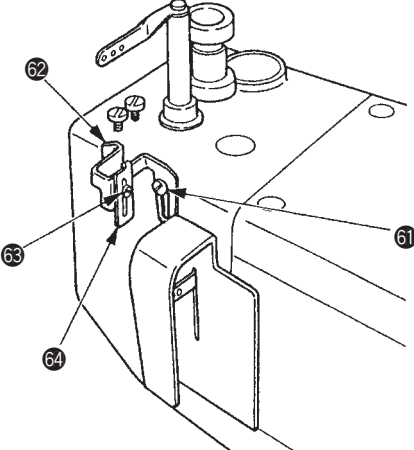
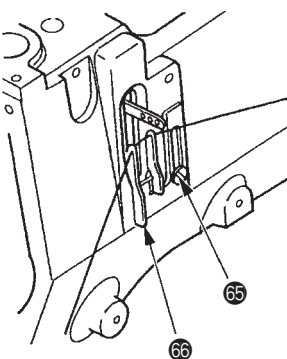
Adjustment Procedures	Results of Improper Adjustment
<ul style="list-style-type: none"> ○ Loosen screw 61 and adjust by moving the needle thread release 62 up and down. ○ Loosen screw 63 and adjust by moving the right needle thread release 64 up and down. 	<ul style="list-style-type: none"> ○ If it is raised, the loop of the needle thread becomes large. ○ If it is lowered, the loop of the needle thread becomes small. ○ If the loop is not formed (the loop is too small) and the skip stitching occurs, raise the needle thread release. ○ If the loop is excessively formed, (the loop is too large) and the skip stitching occurs, lower the needle thread release.
<ul style="list-style-type: none"> ○ Loosen screw 65 and adjust by moving the thread guide 66 up and down. 	<ul style="list-style-type: none"> ○ If it is raised, the thread slackens. ○ If it is lowered, the thread is tightened. ○ Use of the nipper for the threads used Not used for cotton thread and tetoron thread. Used for wooly nylon thread and spun thread (stretching thread). ○ Use of the nipper for the materials used Not used for the light-weight materials of jersey, knit and cloth. Used for the heavy-weight materials of jersey, knit and cloth.

(4) Thread trimmer device (MFC)

Standard Adjustment

1) Stroke adjustment (common to both electromagnetic and pneumatic type)

Stroke A

17mm : Gauge 4.8mm or less

18mm : Gauge 5.6mm or more

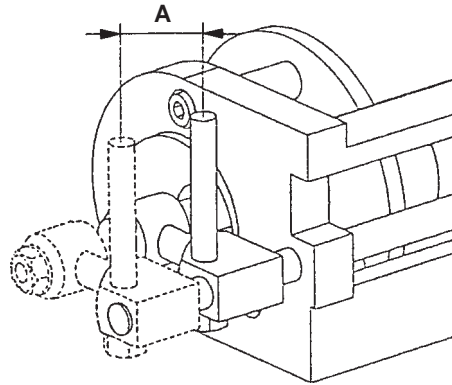

2) Adjustment of the right position of movable knife (return)

Space between lower knife ⑦ and lever ⑧ is to be 0.4 mm

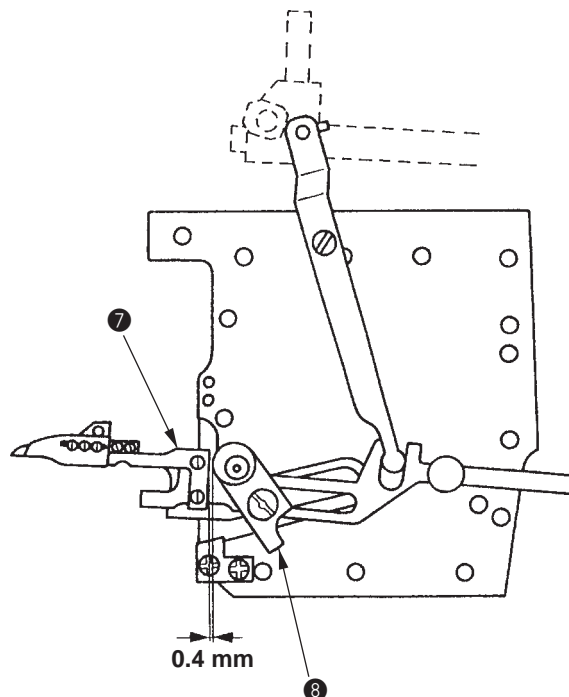

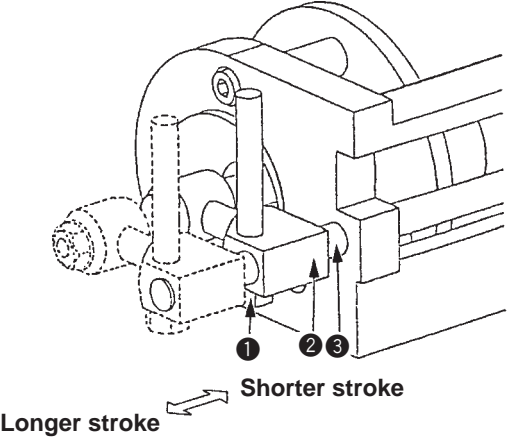
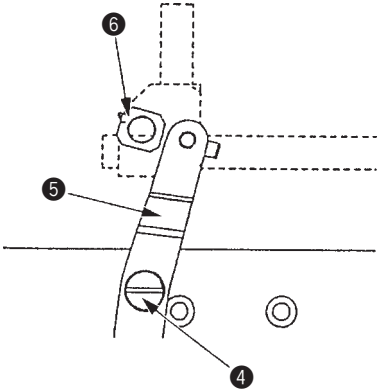
Adjustment Procedures	Results of Improper Adjustment
<p>Loosen the nut ① , and make adjustment by moving the block ② along the shaft ③ .</p> 	<ul style="list-style-type: none"> ○ Too short stroke disables thread cutting. ○ Too large stroke disables looper thread from being clamped.
<p>Remove hinge screw ④ , remove driving lever ⑤ , and make adjustment by turning round the connecting bar ⑥ .</p> 	<ul style="list-style-type: none"> ○ Too little clearance could generate abnormal wear of thread trimmer mechanism, breakage and falling off of the parts. ○ Too large clearance could generate interference of knife with looper.

Standard Adjustment

3) Adjustment of stationary knife and looper thread clamp spring

Overlapping amount between the catching part in pointed end of movable knife ⑩ and pointed end of stationary knife ⑨ is to be 0.5 mm.

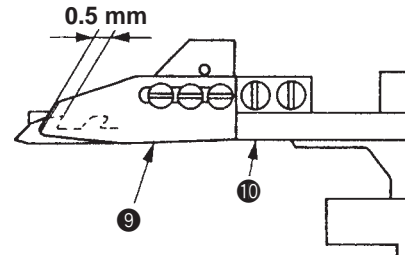

The distance from pointed end of movable knife ⑩ to clamp spring ⑪ is to be 3.2 mm from stationary knife ⑨ to the top end of flat spring ⑫ to be 0.5 mm.

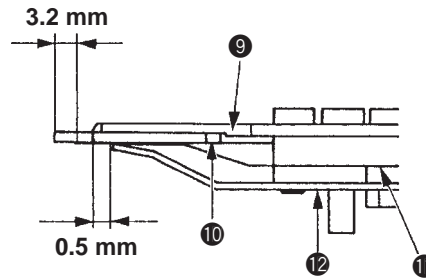

4) Adjustment of the position of movable knife's pointed end

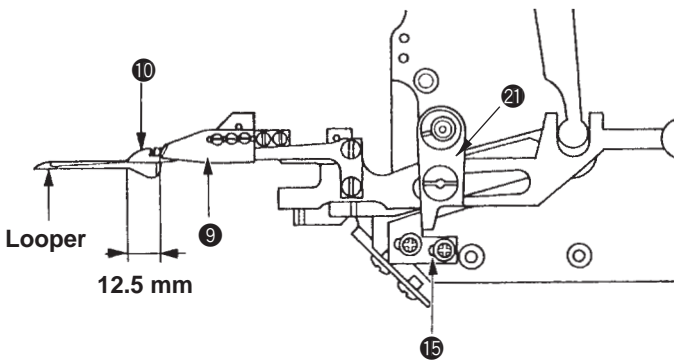

- Position of stopper plate
When looper moves forward all the way to its limit, push on the thread trimmer cylinder by hand so that the distance from the pointed end of stationary knife to the rear of looper is to be 12.5 mm under the state mentioned below.
- The movable knife's pointed end is to be in line with the ridgeline in the flat section of looper top face.
- Stopper plate ⑮ is to be in contact with the lever ⑳.

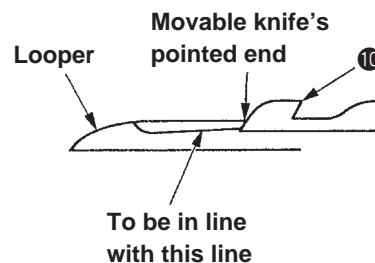
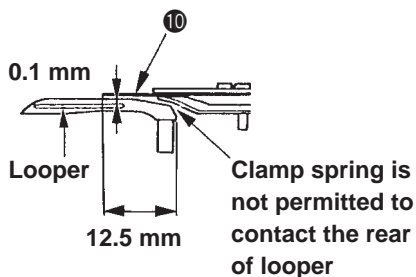

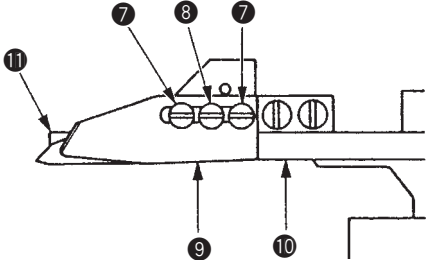
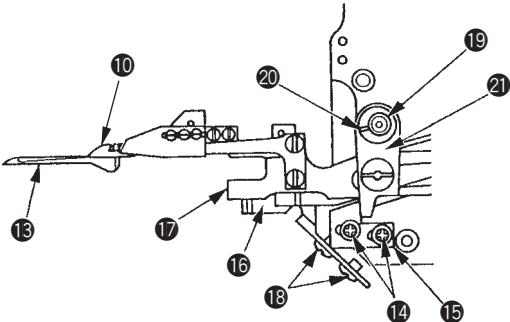
Adjustment Procedures	Results of Improper Adjustment
<p>For the adjustment of stationary knife ⑨ and clamp spring ⑪ , loosen 2 screws ⑦ and a screw ⑧ .</p> <p>Be sure to retain the screw ⑧ which adjusts the clamping pressure after thread trimming and make adjustment of clamping pressure so that looper thread comes off about 3 stitches after start of sewing.</p> <p>Mount the clamp spring ⑪ and stationary knife ⑨ so that they are parallel to the side of movable knife ⑩.</p> 	<ul style="list-style-type: none"> ○ Too small overlapping amount of catching part in pointed end of movable knife with the stationary knife disables cutting of looper thread. ○ Too much distance from the pointed end of movable knife to the top end of clamp spring disables clamping. ○ Too small distance from the stationary knife to the top end of flat spring could cause improper clamping; too much distance could disturb smooth thread threading.
<p>When looper moves forward all the way to its limit, push on the solenoid so that the pointed end of stationary knife is situated 12.5 mm ahead from the rear of looper. In this state :</p> <ul style="list-style-type: none"> ○ Loosen the screw ⑲ so that the pointed end of stationary knife comes to the ridgeline in the flat section of looper top face(Refer to the left illustration), and make adjustment by turning the eccentric ⑳ . ○ Adjust stopper plate ⑮ by loosening 2 screws ⑭, adjust stopper plate so as clamp spring just clears rear of looper. ○ Loosen the 2 screws ⑬ , and move up and down the guide ⑯ so that the guide ⑯ is in contact with the underside of movable knife ⑰ and the clearance between the movable knife ⑰ and the upper face of lower looper ⑬ is to be 0.1mm. 	<ul style="list-style-type: none"> ○ Incorrect adjustment could cause the failure of thread cutting and the thread cast-off at the start of sewing.

Standard Adjustment

5) Adjustment of operating speed of thread trimmer (pneumatic type)

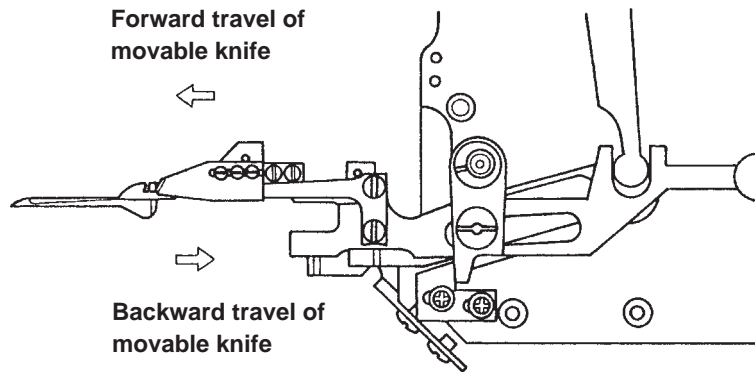

6) Confirmation of thread trimming

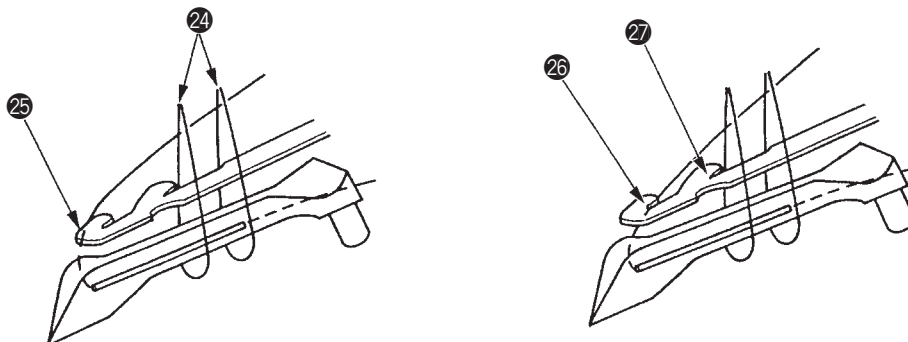

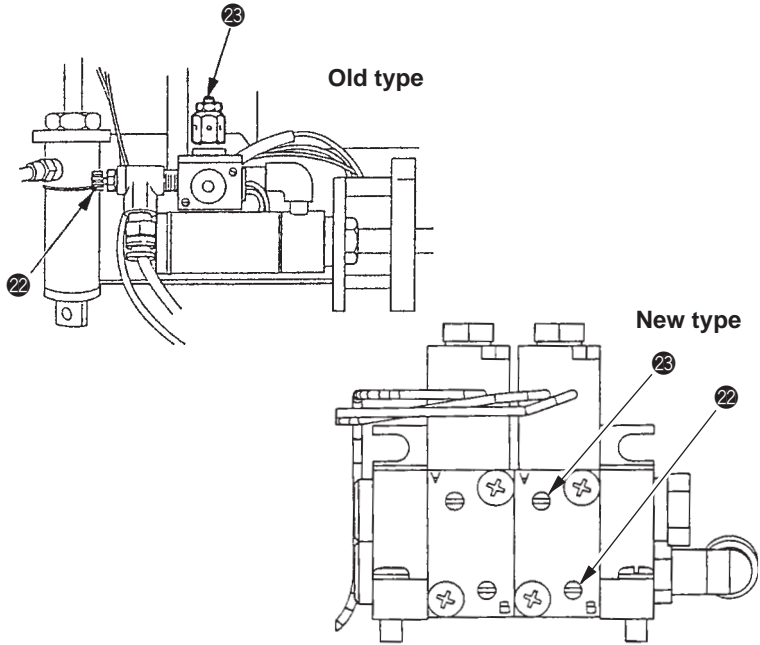
Adjustment Procedures	Results of Improper Adjustment
<ul style="list-style-type: none"> ○ The speed of the forward travel of movable knife is reduced by turning the screw of speed controller 22 clockwise and increased counter-clockwise. ○ The speed of the backward travel of movable knife is reduced by turning the screw of speed controller 23 clockwise and increased counterclockwise. 	<ul style="list-style-type: none"> ○ Incorrect adjustment could cause abnormal wear of mechanism of thread trimmer or failure of thread trimming by insufficient stroke.
<p>After making adjustment of thread trimmer, thread the machine and try to sew and cut off the electric power in a state that the needle bar is situated at the top dead point to disable the operation of the sewing machine and push on the solenoid to confirm the following.</p> <ul style="list-style-type: none"> ○ Movable knife passes through the needle thread loop 24 and makes the looper thread 25 bent. ○ Movable knife starts moving backward after it reaches the end of the left travel, when the looper thread is caught in 26 section of movable knife while the needle thread is caught in 27 section and cut by stationary knife and the looper thread only is retained by the clamp spring. 	

Standard Adjustment

7) Adjustment of pneumatic lifter

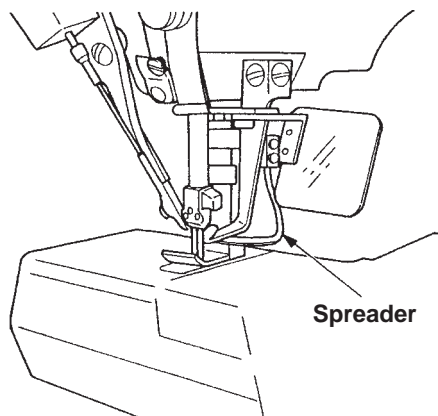

At the time of bottom dead point of needle bar the presser foot should not contact the underside of spreader when lifted.

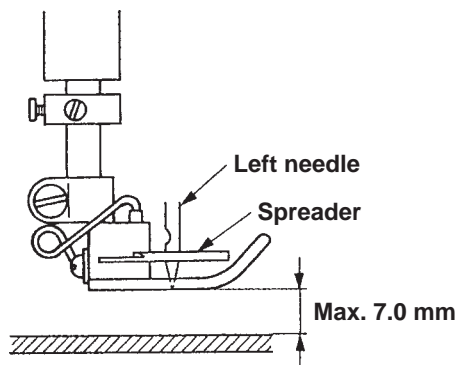

At the time of top dead point of needle bar the left needle point should not go beyond the bottom of presser foot when presser is lifted.

Adjustment Procedures

- Make adjustment by loosening the screw inside 29 so that 29 is mounted around the intermediate point between 2 holes for the hook of lifter lever.
- Adjust the lifting amount of presser foot by turning the cylinder rod 32 loosening the rod end nut 31. (If the cylinder rod becomes too small to turn remove the collar 30.)
- Make adjustment by loosening the nut 33 and turning the screw 34 so that the clearance between the hinge screw 35 and the top end of screw is to be around 1 mm when the presser foot goes down.

Old type

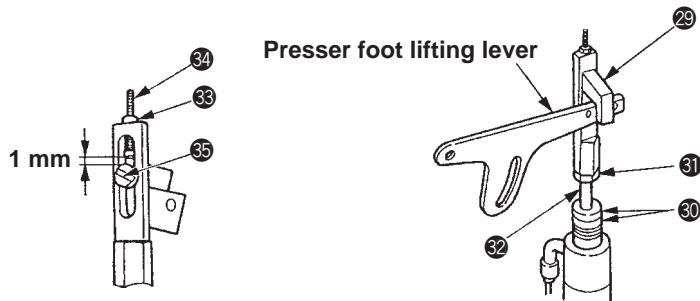

Results of Improper Adjustment

- Too short stroke could cause the insufficient lifting amount.
- Too large stroke could cause the breakage of the spreader, needle clamp and thread guide.
- No clearance made between the hinge screw and stopper screw could cause the presser foot floating.

Standard Adjustment

8) Adjustment of tension release (equipped with thread trimmer)

① Disk floating timing

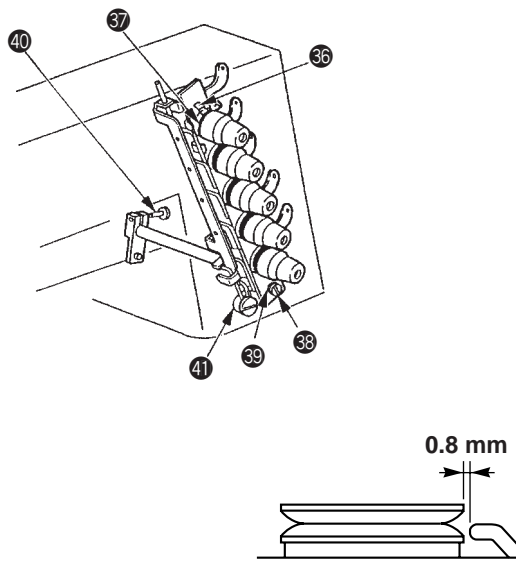

When the presser foot is lowered :

- Tongue 36 in 5 places is near thread tension disk 37 and should not come in contact with it. (0.8 mm)
- Thread tension disk 37 should open immediately after the start of thread trimming.
- Tongue 36 should enter thread tension disk 37 smoothly.

(Caution) The thread trimming mechanism and thread tension release mechanism are interlocked. When they do not work smoothly, check the thread tension release mechanism.

② Thread hauling amount

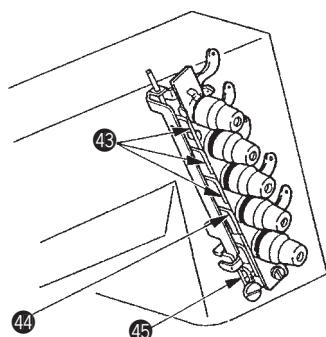

- Adjust the length of remaining needle thread from the needle eyelet after thread trimming with thread tension release hook for needle thread 43 in 3 places.
- Raise thread tension release hook 43 to shorten the length of the remaining thread and lower thread tension release hook 43 to lengthen the length of the remaining thread.
- Adjust thread tension release hook for top covering thread 44 so that top covering thread is correctly clamped after thread trimming.
- Adjust thread tension release hook for looper thread 45 so that looper thread is correctly clamped after thread trimming.

9) Adjustment of proximity switch

This is a contactless switch which prevents the sewing machine from turning due to the defective return of thread trimmer solenoid.

Adjust the thread trimmer solenoid so that LED lights up when it returns and is turned off during the thread trimming.

The clearance is to be 0.5 mm to 0.8 mm.

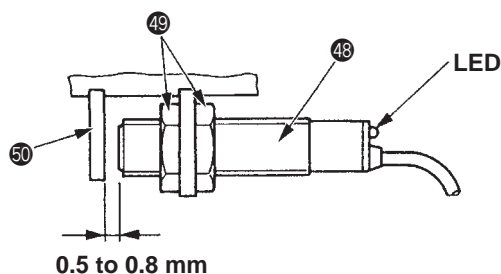

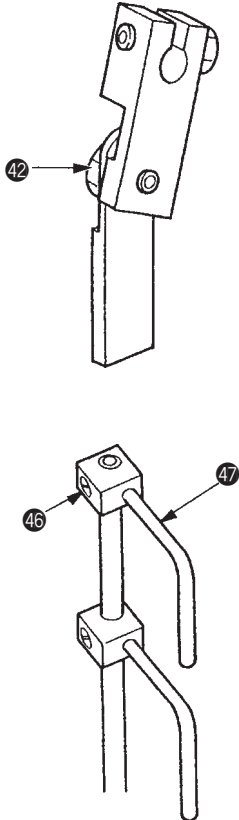
Adjustment Procedures	Results of Improper Adjustment
<p>① Disc float timing</p>  <ul style="list-style-type: none"> ○ Make a provisional adjustment by loosening screw 38 so that it is situated at the center of eccentric nut 39 adjusting range. ○ Loosen the screw 40 . Move the thread tension release lever 41 so that the tongue 36 just contacts the thread tension disc 37 . ○ Remove the hinge screw 42 to confirm that thread trimmer mechanism and thread tension release mechanism work smoothly. ○ Loosen the screw 46 , and move up and down the thread tension release hook 47 . 	<ul style="list-style-type: none"> ○ Incorrect adjustment could cause defective stitch or stitch skip. ○ Too short length of remaining needle thread could cause the needle thread to pull out of needle eye cause stitch skip at the start of sewing. ○ Too long length of remaining needle thread could produce foul seam at the start of sewing.
<p>Loosen the nut. Make the adjustment of clearance between the contactless switch and plate 50 by moving the contactless switch 48 by loosening 2 nuts 49.</p> <p>Confirm the LED's OFF during operation and ON under the normal state by actually cutting the thread several times.</p>	<ul style="list-style-type: none"> ○ Too large clearance disables the running of motor. ○ Too short clearance enables the running of motor due to the defective return of thread trimmer, which could be the cause of the motor damage.

Standard Adjustment

10) Adjustment of top covering thread trimmer

Make adjustment such that the top covering thread cutting movable knife 51 comes to the center in V-shaped slot of spreader when the sewing machine is at rest, and does not contact the spreader 52 and the top covering thread when the movable knife 51 is open.

(Old type)

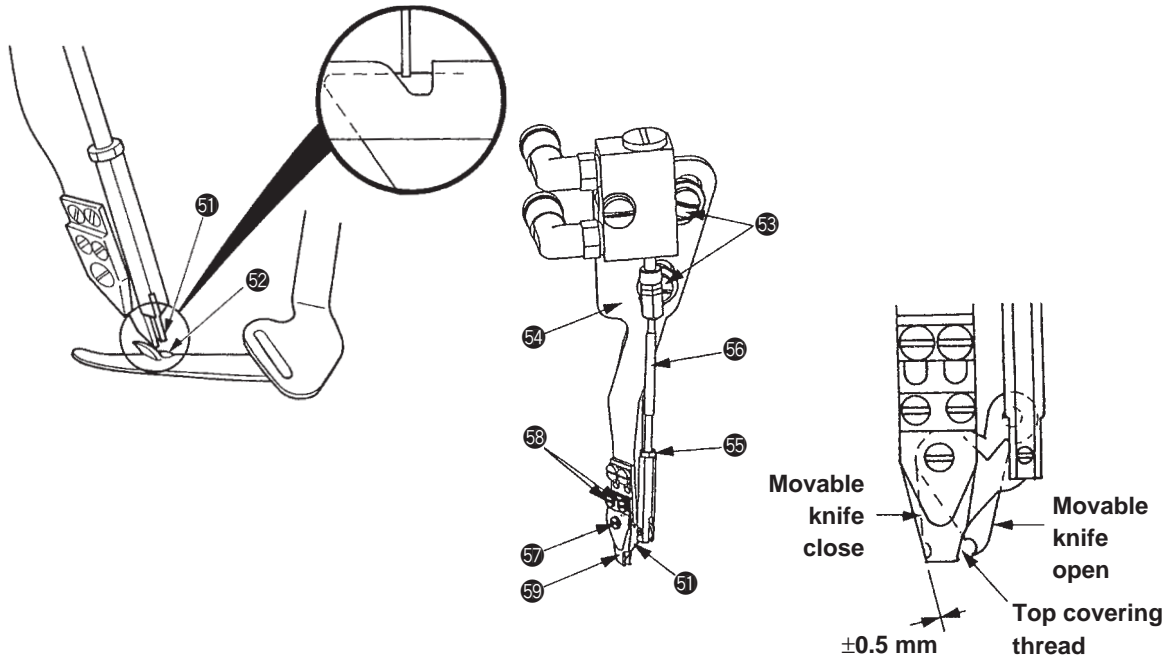

Adjusting cover thread trimme

The following adjustments are made with the needles at top dead center.

(New type)

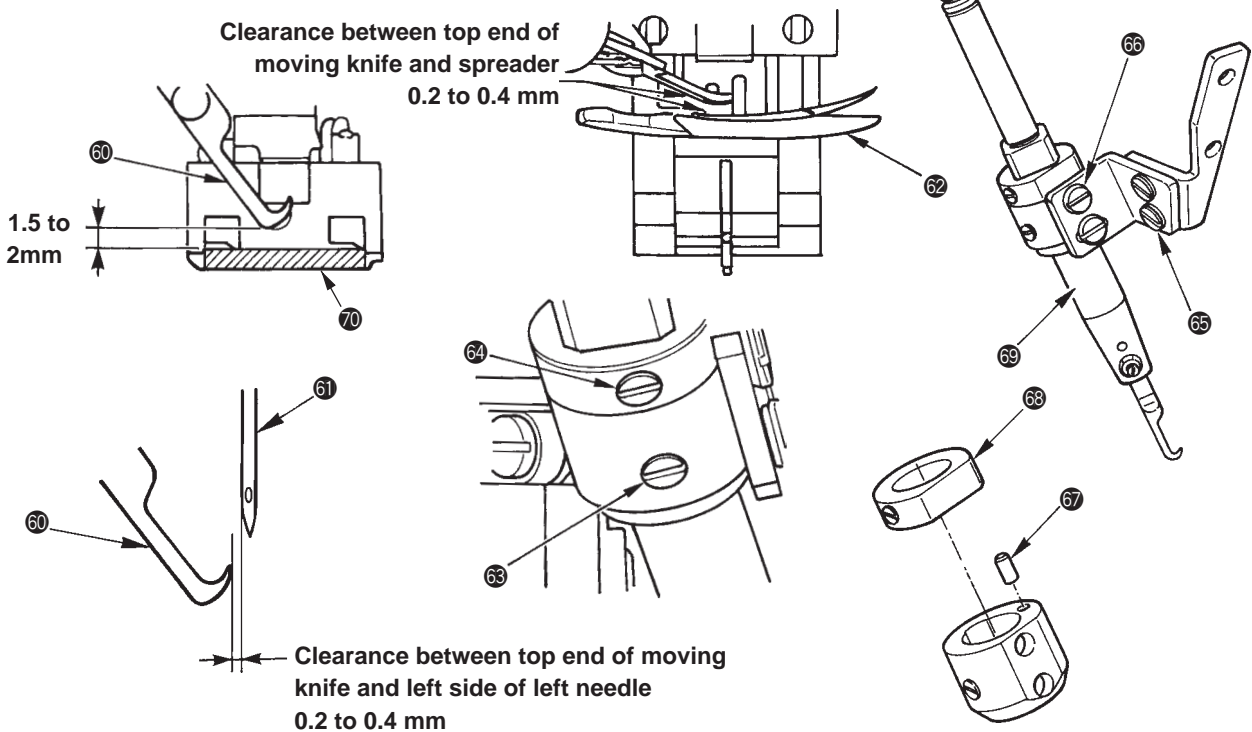

Adjustment Procedures	Results of Improper Adjustment
<ul style="list-style-type: none"> ○ Loosen the 2 screws 53. Move the holder 54 so that the movable knife 51 can come to the center in V-shaped slot of spreader. ○ Loosen the nut 55. Make adjustment by turning the rod 56 such that the pointed end of movable knife coincides with the pointed end of stationary knife (±0.5 mm) when the movable knife is closed, and the movable knife catches and cuts the top cover thread when opened. When the movable knife and stationary knife is found not to be well engaged, loosen the 2 screws 53 and adjust the stationary knife 59. ○ Adjust the retaining pressure by the screw 57 so that the top cover thread is clamped after thread trimming. (An appropriate pressure may be such that the clamp spring is 1/2 turned after contacting the stationary knife.) 	<ul style="list-style-type: none"> ○ Incorrect adjustment could cause breakage of spreader, defect of top cover thread trimming or thread breakage of top cover thread during sewing.
<p>In case of the pneumatic type</p> <ul style="list-style-type: none"> ○ Set the air pressure of moving knife 60 to “0” and adjust the knife so that it cuts the thread retained by spreader 62. ○ The trimmer activates and the hook of moving knife 60 picks up the thread from the underside where the thread goes from spreader 62 to the stitch side. ○ Loosen screws 63 and 64 and adjust so that the bottom of moving knife 60 should be 1.5 to 2 mm above the top surface of presser foot 70 when moving knife 60 is opened to the maximum. ○ Loosen screw 66 and adjust so that the clearance between the top end of moving knife 60 and the left side of the left needle 61 should be 0.4 to 0.8 mm. In addition, loosen screw 65 and adjust so that the clearance between the top end of moving knife 60 and spreader 62 should be 0.2 to 0.4 mm. Loosen screws 63 and 64 and adjust the angle of moving knife 60 so that it should pick up the thread retained by spreader 62. ○ When the adjustment of the trimmer is completed, do not remove collar setscrews 64 since collar 63 holds the adjusted position of the trimmer. ○ When removing the trimmer unit since the trimmer is not used, loosen screw 63 and lift the main body 60 while turning it and there is a position where the unit is drawn. When installing the unit, adjust the groove of collar 68 to pin 67 on the installing base and tighten screw 63 to place it to the home position. ○ Similarly adjust the solenoid type needle thread trimmer. <p>(Caution) Adjust so that the presser foot does not interfere with the trimmer.</p>	

5. ASSEMBLING AND ADJUSTMENT OF FIXED CAM THREAD TAKE-UP

(1) Parts used

Standard Adjustment

<Existing state>

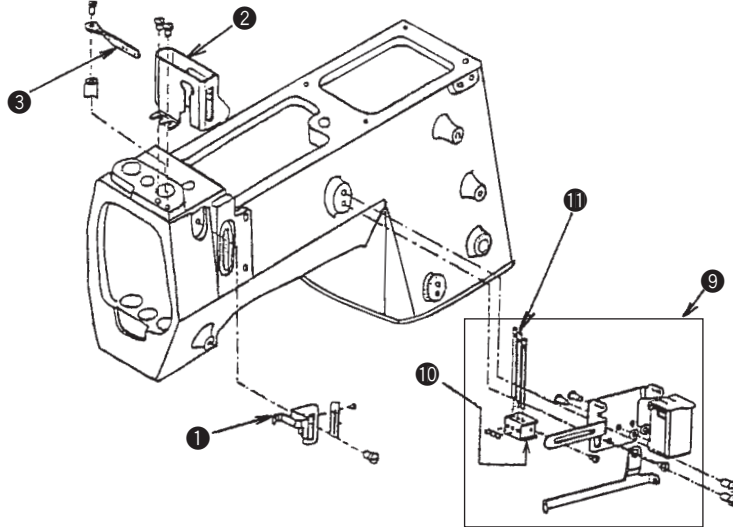

<Changed parts>

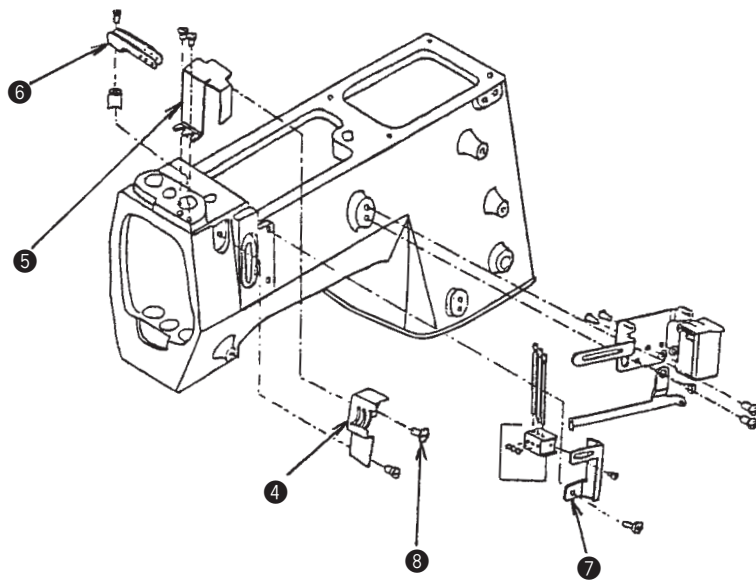

Adjustment Procedures

Results of Improper Adjustment

Deleted parts			Added parts		
	Name of part	Part No.		Name of part	Part No.
❶	Needle thread strike-off asm.	US00050366B	❷	Needle bar cam plate	US00050358Z
❸	Needle bar guard	US00050317C	❹	Needle bar guard	US00050317E
❹	Needle bar thread guide	US00050323P	❺	Needle bar fork thread take-up	US0050363CL
			❻	Medium thread path base	US00050362R
			❼	Screw	SS6110480SP

The screws for ❶ to ❹ are used again when assembling ❺ to ❻. So, do not lose them.

(Caution) The parts ❹ to ❻ are not the deleted ones but those to be removed for performing the work. So, be careful.

- Remove needle thread strike-off asm. ❶, needle bar guard ❷ and needle bar thread guide ❸, and assemble needle bar cam plate ❹, needle bar guard ❺ and needle bar fork thread take-up ❻.
- Temporarily tighten needle bar cam plate ❹ and needle bar guard ❺ with screw ❼ for easy assembling.

(2) Needle bar cam plate and needle bar fork thread take-up

Standard Adjustment

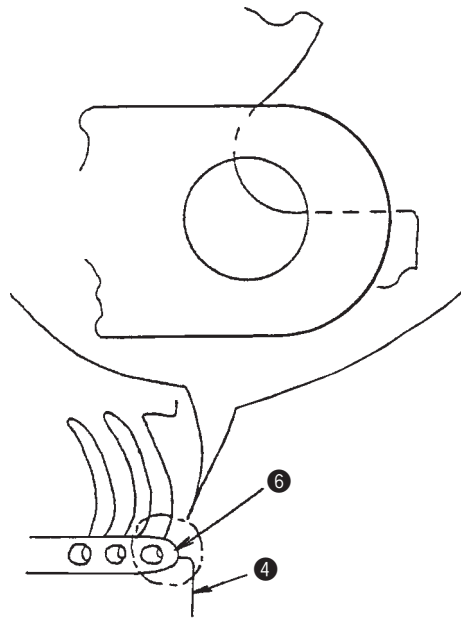

(3) Needle thread guide and medium thread path base

Standard Adjustment

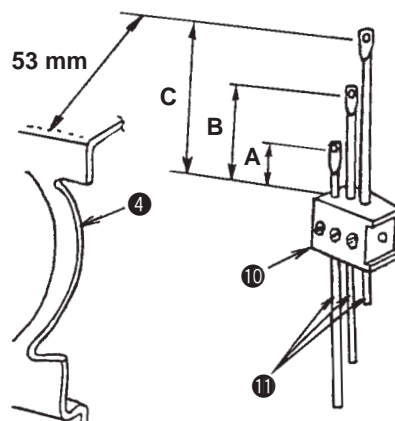

Adjustment Procedures	Results of Improper Adjustment
<p>○ Adjust the vertical position of needle bar cam plate ④ and longitudinal position of needle bar fork thread take-up ⑥ so that the hole for the right needle of needle bar fork thread take-up ⑥ is as shown in the figure on the left-hand side when the needle bar is at its lower dead point. At this time, assemble so that the clearance in the lateral direction between needle bar fork thread take-up ⑥ and needle bar cam plate ④ should be equal.</p> <p>(Caution) See the item (1) Parts used.</p>	<p><When excessively hard-to-slip thread is used> Needle bar cam plate ... Set it higher by 1 to 1.5 mm. Needle bar fork thread take-up ... Adjust it to the front side.</p> <p><When easy-to-slip thread is used> Needle bar cam plate ... Keep as it is. Needle bar fork thread take-up ... Adjust it to the rear side.</p>

Adjustment Procedures	Results of Improper Adjustment												
<p>○ Remove needle thread eyelet installing base ⑩ with the thread guide ⑪ from silicone thread lubricator (asm.) ⑨.</p> <p>○ Temporarily set needle thread eyelet installing base ⑩ to medium thread path base ⑦.</p> <p>○ Tighten medium thread path base ⑦ by using the setscrew located at the upper side of the auxiliary thread take-up cover.</p> <p>○ Adjustment value of needle thread eyelet ⑪ is as described below.</p> <table border="1" data-bbox="338 1601 794 1794"> <thead> <tr> <th></th> <th>MFC</th> <th>MF</th> </tr> </thead> <tbody> <tr> <td>A (left)</td> <td>15 mm</td> <td>22 mm</td> </tr> <tr> <td>B (center)</td> <td>19 mm</td> <td>25 mm</td> </tr> <tr> <td>C (right)</td> <td>21 mm</td> <td>29 mm</td> </tr> </tbody> </table> <p>(Caution) See the item (1) Parts used.</p>		MFC	MF	A (left)	15 mm	22 mm	B (center)	19 mm	25 mm	C (right)	21 mm	29 mm	<p>Horizontal direction : 53 mm from the right-hand side of “needle bar cam plate ④”</p> <p>Height direction : (From the top end of needle thread eyelet installing base to the bottom end of the hold of the thread guide)</p> <p><When desired to decrease the tension with light-weight materials> Increase the whole adjustment values by 1 to 2 mm.</p> <p><When thread breakage occurs frequently with heavy-weight materials> Decrease the whole adjustment values by 1 to 2 mm.</p>
	MFC	MF											
A (left)	15 mm	22 mm											
B (center)	19 mm	25 mm											
C (right)	21 mm	29 mm											

(4) Spreader thread guide

Standard Adjustment

1) Parts used

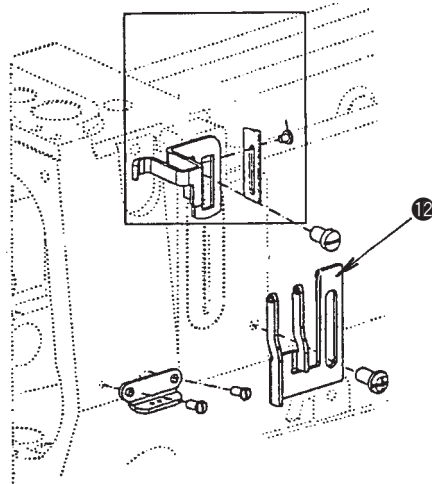

2) Assembling and adjustment of spreader thread guide

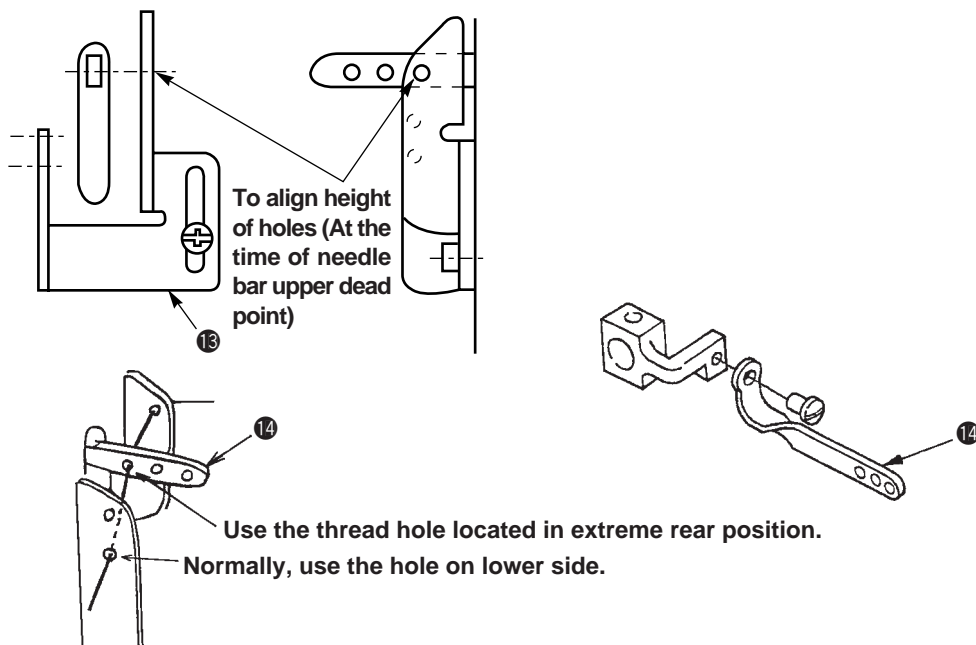

Adjustment Procedures				Results of Improper Adjustment																			
<table border="1"> <thead> <tr> <th colspan="3">Deleted parts</th> <th colspan="3">Added parts</th> </tr> <tr> <th></th> <th>Name of part</th> <th>Part No.</th> <th></th> <th>Name of part</th> <th>Part No.</th> </tr> </thead> <tbody> <tr> <td>❶</td> <td>Eyelet</td> <td>US00050392T</td> <td>❷</td> <td>Spreader thread guide</td> <td>US0050392BG</td> </tr> </tbody> </table>						Deleted parts			Added parts				Name of part	Part No.		Name of part	Part No.	❶	Eyelet	US00050392T	❷	Spreader thread guide	US0050392BG
Deleted parts			Added parts																				
	Name of part	Part No.		Name of part	Part No.																		
❶	Eyelet	US00050392T	❷	Spreader thread guide	US0050392BG																		
<ul style="list-style-type: none"> ○ Remove eyelet ❶ and install spreader thread guide ❷. ○ Adjust the vertical position of the spreader thread guide so that the relation between the thread hole position of auxiliary thread take-up thread guide ❸ and the spreader thread guide ❷ is as shown in the figure at the time of the lowest point of the needle bar. 				<p>The hole on the left-hand side of the spreader thread guide :</p> <p><When general thread is used> Use the hole located on the lower side.</p> <p><When stretchy thread is used> Use the hole located on the upper side.</p>																			

6. OTHER PRECAUTIONS

(1) Points to which Locktite is applied

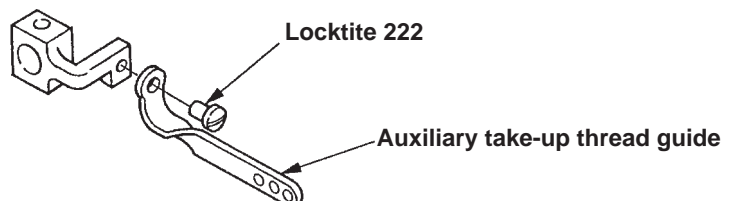



7. TROUBLES AND CORRECTIVE MEASURES

Troubles	Cause (1)	Cause (2)	Corrective measures	
1. Thread breakage	Threading	Thread caught in thread guide, Incorrect threading	Refer to threading diagram.	
	Thread path	Resistance produced by flaw, burr, rust etc. around needle entry of throat plate, stitch tongue, looper, spreader, needle thread take-up nipper, needle guide, thread tension disc etc.	Remove the flaw, burr etc. and process the thread guide finish. However, replace such important parts as looper or throat plate etc. with the new part because their shape is changed by being processed.	
	Needle guard	Strong contact of needle against needle guard produces a sharp edge in needle guard resulting in thread breakage.	In case needle exchanger, or looper needle guard is worn out, replace it with the new part.	
	Needle	Too thin needle for the thread used	Replace it with an appropriate needle.	
	Needle heat	Needle is heated depending on fabric type, number of fabrics, sewing speed resulting in thread breakage.	Use thinner needle. Reduce the sewing speed. Use silicon oil lubricant device.	
	Thread	Poor quality and weakness of thread	Replace it with the thread of good quality.	
	Thread tension	Too strong thread tension	Reduce thread tension. Intermediate thread guide is positioned too high making the thread tension too strong.	
	Interference	Interference with feed dog, throat plate due to the incorrect mounting height of looper	Mount it in the correct position.	
	Chain-off thread defect	Flaw produced in stitch tongue in throat plate, feed dog, tongue in presser foot, underside in presser foot	Remove the flaw, burr etc.	
	Thread guide	Resistance produced by flaw, burr, rust etc. in stitch tongue in throat plate, looper, looper thread cam, thread guide, thread tension disc	Remove the flaw, burr etc. and process the thread guide finish. However, replace such parts as looper with the new part because its shape is changed by being processed.	
	Looper thread cam adjustment	Excessive tension applied due to the incorrect position of looper thread cam timing, thread guide	Refer to standard adjustment.	
	Thread tension	Too strong tension of looper thread	Reduce the thread tension while checking to see the tension balance against the needle thread, top covering thread.	

To the next page →

Troubles	Cause (1)	Cause (2)	Corrective measures
From the previous page	Thread	Poor quality and weakness of thread	Replace it with good quality of thread.
	Looper avoid	Too strong contact of looper back with needle resulting in thread breakage	Adjust moving amount, front and rear of looper so that looper contacts the needle at 2/3 height of top of the back.
	Needle heat	In case needle heat is generated looper thread's contact with needle causes thread breakage, specially at the time machine is at rest.	Refer to needle heat in needle breakage
3. Needle breakage	Needle entry	Needle hits the throat plate or presser foot because the needle entry is not correctly positioned for the plate or foot.	Align the needle entry to the needle.
	Spreader	Too little clearance between spreader and needle	Refer to standard adjustment
	Interference of looper with scooping movement of needle	Needle hits looper resulting in needle breakage.	Make adjustment so that looper does not hit the looper. For the correction of the contact at looper's back, adjust the moving amount, front and rear.
	Needle guard	Too strong contact against needle guard or needle point hits needle guard due to incorrect position.	Refer to standard adjustment
	Needle thickness No.	Too thin needle for fabric used	Use thicker needle.
	Thread tension	Needle thread tension is too strong.	Reduce the needle thread tension.
	Feed height, Needle height	Feed dog is too high or needle height is too low resulting in needle breakage due to needle swerve.	Refer to standard adjustment value.
4. Worn out needle point	Needle guard	Incorrect height or incorrect position, front and rear	Check to see the height of needle guard and clearance between needle guard and needle.
	Interference with looper	Moving amount, front and rear is ill balanced.	Adjust moving amount, front and rear and correct the incorrect position of looper's back and the contact when it returns.





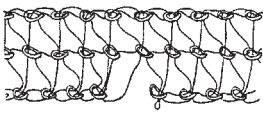

Troubles(1)	Troubles(2)	Cause (1)	Cause (2)	Corrective measures
Stitch skipping	<p>Looper does not scoop the right needle thread.</p>  <p>Left Right</p>	<p>Looper</p> <p>Needle</p> <p>Nipper</p> <p>Intermediate thread guide</p> <p>Needle height</p> <p>Threading</p> <p>Needle guard</p> <p>Spreader</p> <p>Needle heat</p> <p>Looper adjustment</p> <p>Needle guard, front and rear</p>	<p>Incorrect shape of pointed end of looper disables scooping a loop.</p> <p>Needle bend, incorrect needle mounting direction, wrong needle</p> <p>Not used.</p> <p>Too high</p> <p>Needle bar position is too high.</p> <p>Incorrect threading</p> <p>Not used.</p> <p>Spreader thread tension is too strong.</p> <p>Stitch skip occurs before thread breakage produced by needle heat.</p> <p>Incorrect clearance adjustment, incorrect returning amount adjustment</p> <p>Incorrect contact amount, incorrect height</p>	<p>Replace it with the genuine part.</p> <p>Replace the needle with new one, Correct the mounting direction, Use UY121GJS CS100, UY128 GBS FS300.</p> <p>Use nipper.</p> <p>Correct the height to appropriate height.</p> <p>Refer to standard adjustment.</p> <p>Refer to threading diagram.</p> <p>Use needle guard.</p> <p>Reduce the tension.</p> <p>Same described in page " Thread breakage by needle heat"</p> <p>Refer to standard adjustment.</p> <p>Refer to standard adjustment.</p>
	<p>Looper does not scoop the middle needle thread.</p>  <p>Left Right</p>	<p>Looper</p> <p>Needle</p> <p>Nipper</p> <p>Intermediate thread guide</p> <p>Needle height</p> <p>Threading</p>	<p>Incorrect shape of pointed end of looper disables scooping a loop.</p> <p>Needle bend, incorrect needle mounting direction, wrong needle</p> <p>Being used.</p> <p>Height is too low.</p> <p>Needle bar height is too low.</p> <p>Incorrect threading</p>	<p>Replace it with the genuine part.</p> <p>Replace the needle with new one, Correct the mounting direction, Use UY121GJS CS100, UY128 GBS FS300</p> <p>Do not use nipper.</p> <p>Correct height position to appropriate height.</p> <p>Refer to standard adjustment.</p> <p>Refer to threading diagram.</p>

To the next page

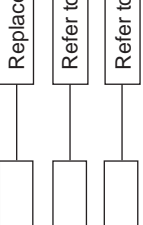
To the next page

Troubles(1)	Troubles(2)	Cause (1)	Cause (2)	Corrective measures
From the previous page	From the previous page	Needle thread guard	Being used.	Do not use.
		Spreader	Spreader thread tension is too strong.	Reduce the tension.
		Needle heat	Stitch skip occurs before thread breakage produced by needle heat.	Same described in page "Thread breakage by needle heat"
		Looper adjustment	Incorrect clearance adjustment, incorrect returning amount adjustment	Refer to standard adjustment.
		Needle guard, front and rear	Incorrect contact amount, incorrect height	Refer to standard adjustment.
		Looper	Incorrect shape of pointed end of looper disables scooping a loop.	Replace it with the genuine part.
	<p>Looper does not scoop the left needle thread.</p>  <p>Left Right Left Right</p>	Needle	Needle bend, incorrect needle mounting direction, wrong needle	Replace the needle with new one, Correct the mounting direction, Use UY121GJS CS100, UY128 GBS FS300.
		Nipper	Being used.	Do not use nipper.
		Intermediate thread guide	Height is too low.	Correct height position to appropriate height.
		Needle height	Height is too low.	Refer to standard adjustment.
		Threading	Incorrect threading	Refer to threading diagram.
		Needle guard	Being used.	Do not use.
		Spreader	Too near to the left needle	Refer to standard adjustment.
		Needle heat	Stitch skip occurs before thread breakage produced by needle heat.	Same described in page "Thread breakage by needle heat"
		Looper adjustment	Incorrect clearance adjustment, incorrect returning amount	Refer to standard adjustment.
		Needle guard, front and rear	Incorrect contact amount, incorrect height	Refer to standard adjustment.

To the next page →

Troubles(1)	Troubles(2)	Cause (1)	Cause (2)	Corrective measures
From the previous page	<p>Needle does not scoop the looper thread. (Triangle stitch skip) Middle needle Left needle</p>	Looper	Ventral shape is incorrect.	Replace it with the genuine part.
 <p>Stitch skip by middle needle</p>	Needle	Needle bend	Replace the needle with the new one.	
	Needle height	Needle bar position is too high.	Refer to standard adjustment.	
	Threading	Incorrect threading	Refer to threading diagram.	
 <p>Slack of looper thread</p>	Looper adjustment	Incorrect clearance adjustment, incorrect returning amount	Refer to standard adjustment.	
 <p>Slack of looper thread</p>	Looper thread tension	Tension is too weak.	Increase tension.	
 <p>Slack of looper thread</p>	Looper thread cam timing	Looper thread cam timing is too fast.	Refer to standard adjustment.	

To the next page →

Troubles(1)	Troubles(2)	Cause (1)	Cause (2)	Corrective measures
-------------	-------------	-----------	-----------	---------------------

From the previous page

Skipping in top cover stitch (right)	Spreader	Incorrect shape of pointed end of spreader disables scooping a thread.	Replace it with the genuine part.
	Needle	Needle bend, wrong needle	Replace the needle with the new one, Use UY121GJS CS100, UY128 GBS FS300.
	Spreader adjustment	Incorrect height, protruding amount, position, front and rear	Refer to standard adjustment.
	Stationary spreader thread guide	Incorrect height, position	Refer to standard adjustment.
	Needle height	Needle bar position is too low.	Refer to standard adjustment.
	Threading	Incorrect threading	Refer to threading diagram.
	Needle clamp spreader thread guide	Incorrect height, position, front and rear	Refer to standard adjustment.
	Spreader thread tension	Spreader thread tension is too weak.	Increase tension.
	Spreader take-up thread drawing-in amount	Incorrect drawing-in amount of thread	Refer to standard adjustment.

Skipping in top covering stitch by right needle

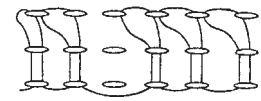
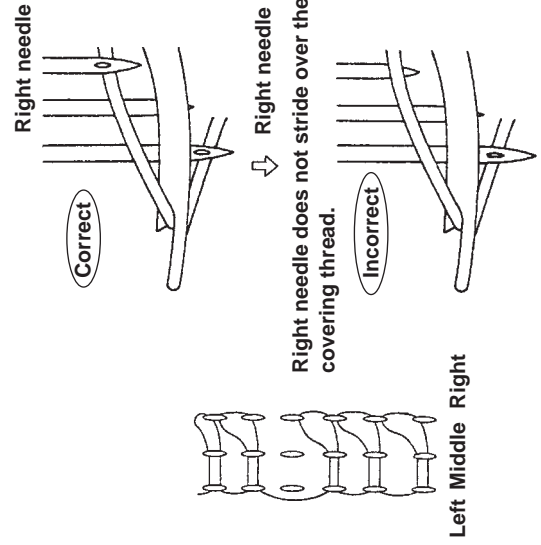

Left Middle Right

Skipping in top covering stitch by right needle Simultaneous skip by left and middle needle

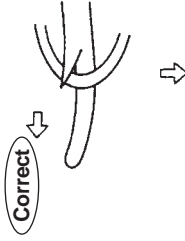

Spreader does not fetch the top covering thread.

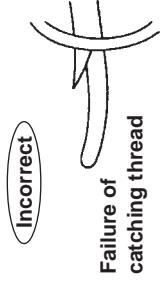

To the next page

Troubles(1)	Troubles(2)	Cause (1)	Cause (2)	Corrective measures
	From the previous page			
	Skipping in top covering stitch (Middle)	Needle	Needle bend, wrong needle	Replace the needle with the new one, Use UY121GJS CS100, UY128GBS FS300.
		Spreader adjustment	Incorrect height, protruding amount, position, front and rear	Refer to standard adjustment.
		Needle height	Incorrect needle bar position	Refer to standard adjustment.
		Threading	Incorrect threading	Refer to threading diagram.
		Spreader thread tension	Spreader thread tension is too weak.	Increase tension.
		Spreader pull-off	Incorrect drawing-in amount of thread	Refer to standard adjustment.
		Stationary spreader thread guide	Incorrect height and position	Refer to standard adjustment.



Left Middle Right

Skipping in top covering stitch by middle needle
Middle needle does not scoop top covering thread.

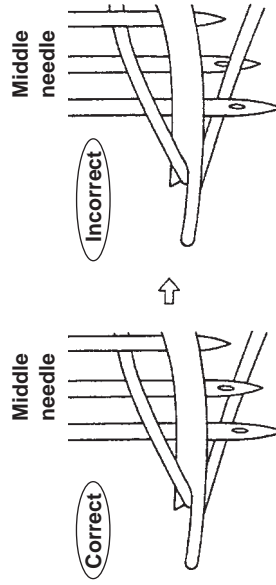

Middle needle strides over top covering thread sometimes.

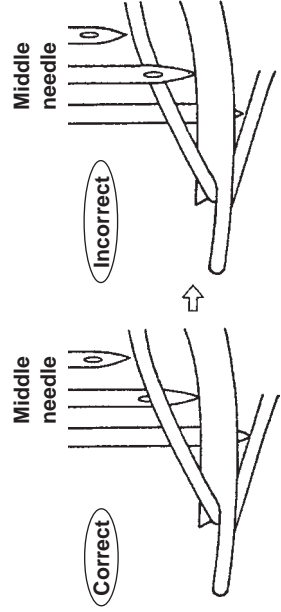

To the next page

Troubles(1)	Troubles(2)	Cause (1)	Cause (2)	Corrective measures
	From the previous page			
	Skipping in top covering stitch (Left)	Spreader	Incorrect shape of pointed end disables scooping a thread.	Replace it with the genuine part.
		Needle	Needle bend, wrong needle	Replace needle with new one, Use UY121GJS CS100, UY128GBS FS300.
		Spreader adjustment	Incorrect height, protruding amount, position, front and rear	Refer to standard adjustment.
		Stationary spreader thread guide	Incorrect height and position	Refer to standard adjustment.
		Needle height	Needle bar position is too low.	Refer to standard adjustment.
		Threading	Incorrect threading	Refer to threading diagram.
		Spreader thread tension	Spreader tension is too weak.	Increase tension.
		Spreader pull-off drawing-in amount of thread	Incorrect drawing-in amount of thread	Refer to standard adjustment.

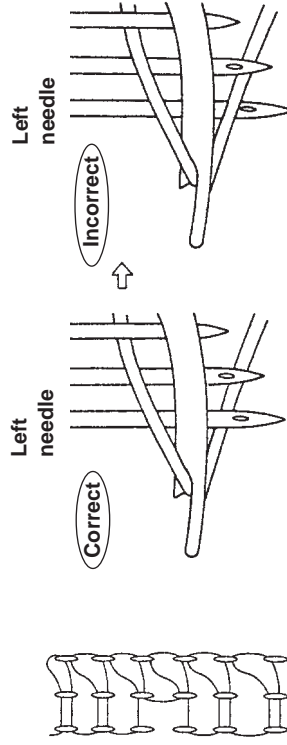





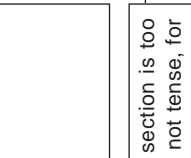

Skipping in top covering stitch by left needle
Left needle does not scoop top covering thread.

To the next page

Troubles(1)	Troubles(2)	Cause (1)	Cause (2)	Corrective measures
From the previous page	Single chain thread cast-off (Right, Middle, Left)	Needle	Needle bend, wrong needle	Replace the needle with the new one, Use UY121GJS CS100, UY128GBS FS300.
		Needle height	Needle bar position is too high.	Refer to standard adjustment.
		Threading	Incorrect threading	Refer to threading diagram.
		Throat plate	R of stitch tongue in throat plate is too small.  Incorrect polishing	Increase R. Polish correctly.
		Looper	R of looper's ventral section is too large and ridgeline is not tense, for which needle thread is likely to slip from looper.	Replace it with the genuine part.
		Looper adjustment	Too little contact amount between looper's back and needle	Refer to standard adjustment.
		Thread tension	Thread tension is too weak.	Increase tension.
		Intermediate thread guide position	Low position of thread guard results in too large needle thread loop.	Lift thread guide position.
		Thread guard position	Thread guard position is too high.	Refer to standard adjustment.
		Nipper	Use of nipper could easily generate this trouble.	Do not use nipper.
		Looper thread cam thread guide position	Drawing-in amount of looper thread is too much.	Reduce drawing-in amount of thread.

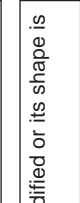
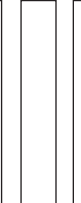
To the next page →

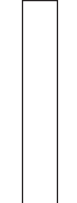
Troubles(1)	Troubles(2)	Cause (1)	Cause (2)	Corrective measures
From the previous page	<p>Double bonding stitch (Middle, Left)</p> 	Throat plate	R of stitch tongue in throat plate is too large. Stitch tongue is too short.	Replace it with the genuine part.
	<p>Needle</p>	 <p>Worn out needle point, needle bend, wrong needle</p>	Replace needle with new one, Use UY121GJS CS100, UY128GBS FS300.	
<p>Right needle enters middle needle loop.</p> 	Looper	Flaw in looper's ventral section, incorrect polishing	Replace the looper when modified or its shape is changed too much.	
	Needle height	Needle bar position is too low.	Refer to standard adjustment.	
	Threading	Incorrect threading	Refer to threading diagram.	
	Needle thread tension	Tension is too weak.	Increase tension.	
	Intermediate thread guide position	Thread guide position is too low.	Lift the thread.	
	Nipper	Use of nipper is likely to generate this trouble.	Do not use nipper.	

Middle needle enters left needle loop.



To the next page

Troubles(1)	Troubles(2)	Cause (1)	Cause (2)	Corrective measures
From the previous page	Irregular stitches (Left, Middle, Right)	Throat plate Spreader adjustment Looper Top covering thread take-up Needle thread tension Threading Top covering thread tension Looper thread cam thread guide position	Incorrect polishing Stroke of spreader is too large. Worn out looper's pointed end and incorrect polishing Drawing-in amount of top covering thread is too much. Needle thread tension is too weak. Incorrect threading Thread tension is too weak. Drawing-in amount of looper thread is too much.	Polish correctly. Refer to standard adjustment. Replace the looper when modified or its shape is changed too much. Refer to standard adjustment. Increase tension. Refer to threading diagram. Increase tension. Reduce drawing-in amount of thread.
	Ill-tensed seam	Throat plate Needle Looper Needle height Threading Needle thread tension Intermediate thread guide position Looper thread tension Looper thread cam thread guide position	Incorrect polishing, Too long stitch tongue Worn out needle point, needle bend, wrong needle Worn out looper's pointed end, incorrect polishing Needle bar position is too low. Incorrect threading Tension is too weak. Thread guide position is too low. Tension is too strong. Drawing-in amount of looper thread is too little.	Correct or replace part. Replace needle with new one, Use UY121GJS CS100, UY128GBS FS300. Replace the looper when modified or its shape is changed too much. Refer to standard adjustment. Refer to threading diagram. Increase tension. Lift the position Reduce tension. Increase drawing-in amount of thread.

From the previous page

To the next page

Troubles(1)	Troubles(2)	Cause (1)	Cause (2)	Corrective measures
From the previous page	Irregular stitches in top covering stitches	Spreader	Flaw in pointed end of spreader obstructs smooth thread threading.  Flaw	Replace when modified or its shape is changed too much.
		Spreader adjustment	Spreader stroke is too large.	Refer to standard adjustment.
		Thread guide	Flaw, burr in slot	Replace when modified or its shape is changed too much.
		Top covering thread take-up	Drawing-in amount of top covering thread is too much or too little.	Refer to standard adjustment.
		Needle thread tension	Needle thread tension is too weak.	Increase tension.
		Threading	Incorrect threading	Refer to threading diagram.
		Top covering thread tension	1st thread tension is too weak.	Increase tension.
		Looper thread cam thread guide position	Drawing-in amount of looper thread is too much.	Reduce drawing-in amount of thread.
		Stitch tongue of presser foot	Thread threading is not smooth due to incorrect shape of stitch tongue.	Replace when modified or its shape is changed too much.
	Bulge	Throat plate	Stitch tongue is too short.	Use throat plate provided with long stitch tongue.
		Threading	Incorrect threading	Refer to threading diagram.
		Needle thread tension	Tension is too strong.	Reduce tension.
		Looper thread tension	Tension is too strong.	Reduce tension.
		Looper thread cam thread guide position	Drawing-in amount of upper thread is too little.	Increase drawing-in amount.

To the next page ▶

Troubles(1)	Troubles(2)	Cause (1)	Cause (2)	Corrective measures
From the previous page	Defective chain-off thread (with top covering stitch)	Throat plate	Thread threading is not smooth due to incorrect polishing in stitch tongue.	Replace when polished or its shape is changed too much.
		Spreader adjustment	Stitch skip in top covering stitch due to incorrect adjustment	Refer to standard adjustment.
		Looper adjustment	Stitch skip due to incorrect adjustment	Refer to standard adjustment.
		Top covering thread take-up	Drawing-in amount of top covering thread is too much or too little.	Refer to standard adjustment.
		Needle thread tension	Needle thread tension is too weak.	Increase tension.
		Threading	Incorrect threading	Refer to threading diagram.
		Top covering thread tension	1st thread tension is too weak.	Increase tension.
		Stitch tongue of presser foot	Thread threading is not smooth due to incorrect shape of stitch tongue.	Replace when its shape is modified or changed too much.
		Needle	Worn out needle point, needle bend, wrong needle	Replace needle with new one, Use UY121GJS CS100, UY128GBS FS300.
		Feed dog	Flaw on surface in feed dog	Modify or replace.
	Stitch skip & stitch missing at start of sewing after thread trimming (thread trimmer sewing machine, bottom covering stitch)	Double cutting	Remaining thread is too short by double cutting.	Refer to standard adjustment.
		Looper thread clamp	Clamping force is too weak.	Increase clamping force.
		Pulling-in of thread	Pulling-in amount of thread is too little at time of thread trimming.	Increase pulling-in amount.
		Mechanical wiper	Clamping force is too weak.	Increase clamping force.
		Pneumatic wiper	Needle is entangled with thread by incorrect direction of air blow outlet.	Correct direction so that remaining thread flows to presser bar side.
		Presser foot	Falling speed of presser is too slow in automatic lifter.	Increase falling speed. (to get rid of shaky movement etc.)

To the next page

Troubles(1)	Troubles(2)	Cause (1)	Cause (2)	Corrective measures
Defective thread trimmer	Unable to trim needle thread, looper thread	Returning position of movable knife	Insufficient returning amount of movable knife disables engagement with stationary knife.	Refer to standard adjustment.
		Stationary knife	Worn out edge, nicked edge disables sharp cutting.	Sharpen or replace edge.
		Timing of thread trimming	Incorrect looper stopping position	Refer to standard adjustment.
		Movable knife stroke	Inappropriate stroke	Refer to standard adjustment.
		Clearance between movable knife and looper	Incorrect position, front and rear, of movable knife against looper's backposition	Refer to standard adjustment.
		Engaging pressure (Movable and stationary knife)	Engaging pressure is too weak.	Refer to standard adjustment.
	Unable to trim top covering thread	Intermediate thread guide position	Thread guide position is too low.	Lift the position.
		Stationary knife	Worn out edge, nicked edge disables sharp cutting.	Sharpen or replace edge.
		Initial position	Incorrect position of knife against spreader	Refer to standard adjustment.
		Spreader stopping position	Incorrect spreader stopping position (Sewing machine is at rest)	Make adjustment so that sewing machine is brought to rest at the top dead point of needle bar.
		Engagement between movable and stationary knives	Insufficient engaging amount disables cutting of thread.	Refer to standard adjustment.
		Opening amount of movable knife	Insufficient opening amount of movable knife disables catch of thread.	Refer to standard adjustment.
		Clamping pressure	Clamping pressure is too weak.	Refer to standard adjustment.
	From the previous page	Top covering thread clamp	Clamping force is too weak.	Increase clamping force.
		Pulling-in of covering thread	Pulling-in amount of covering thread is too little at time of thread trimming.	Increase pulling-in amount.

8. DRAWING OF TABLE

(1) Semi-submerged type for MF

①

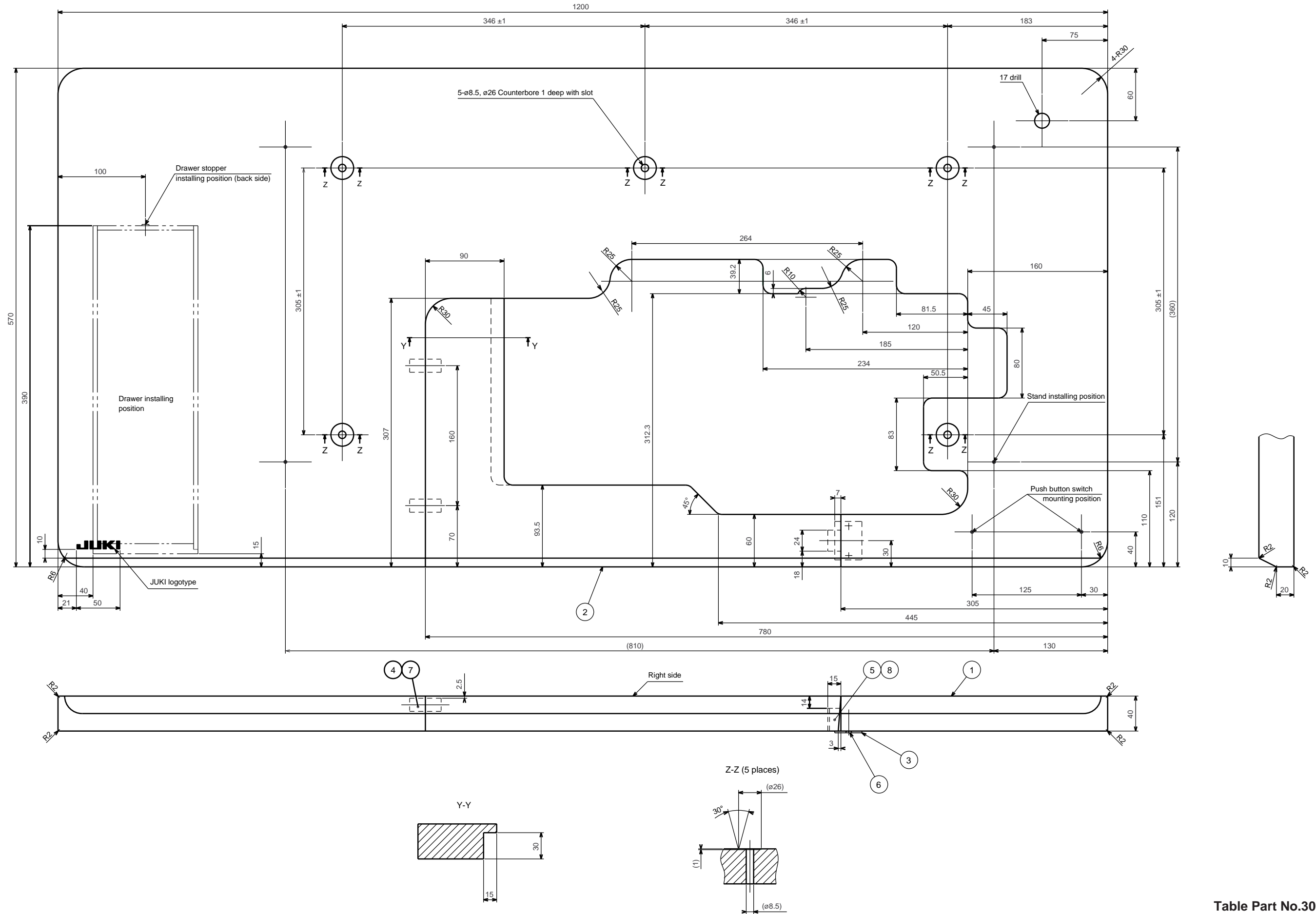
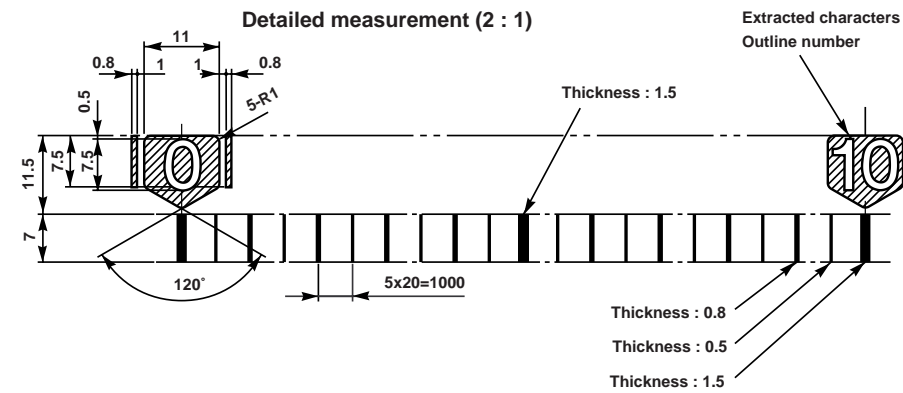
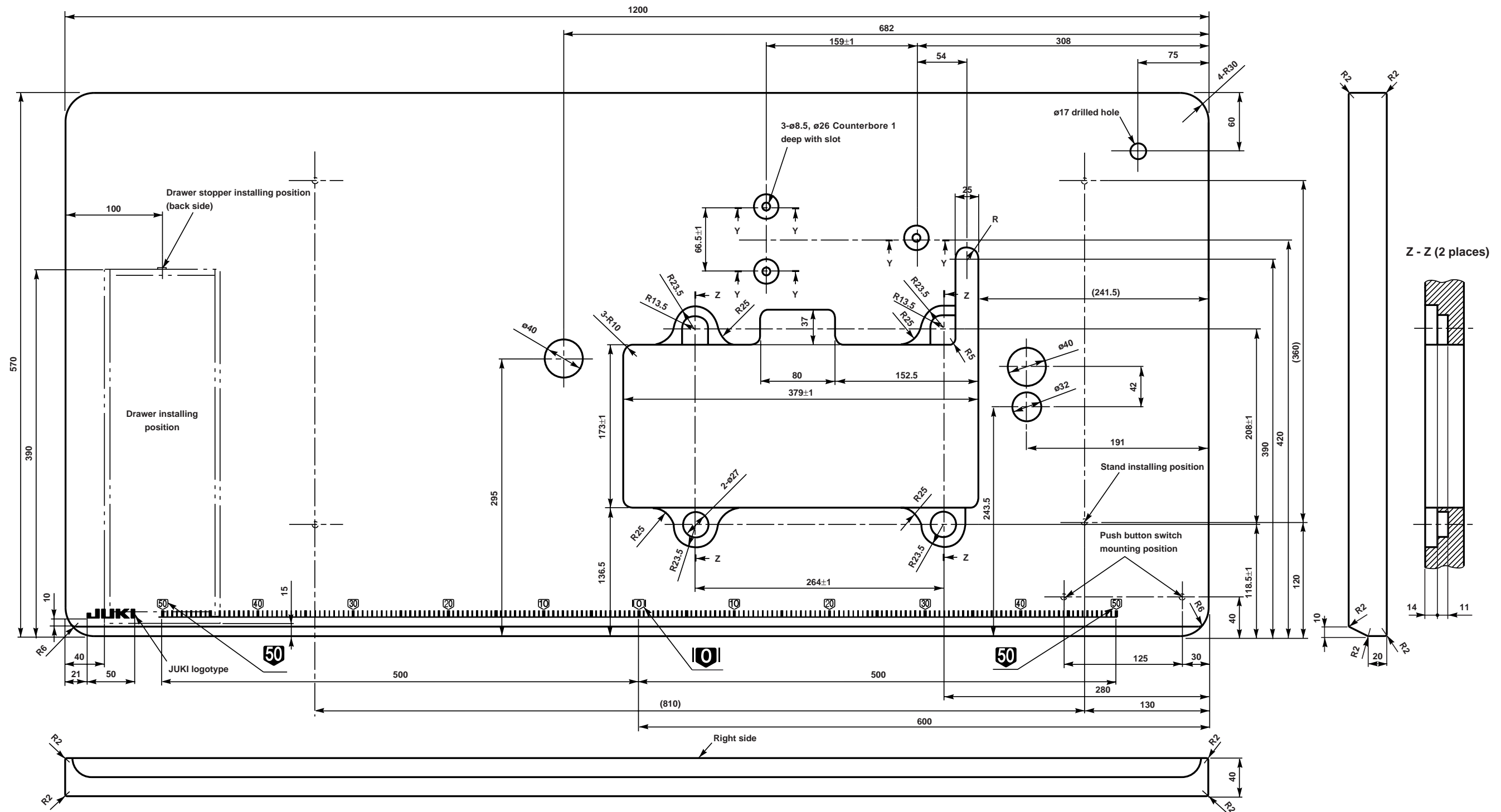
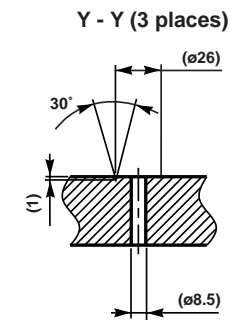

Table Part No.30148654

(2) Desktop type for MF



Extracted characters : Helvetica Reg. Condensed
Outline number



(4) Desktop type for MFC

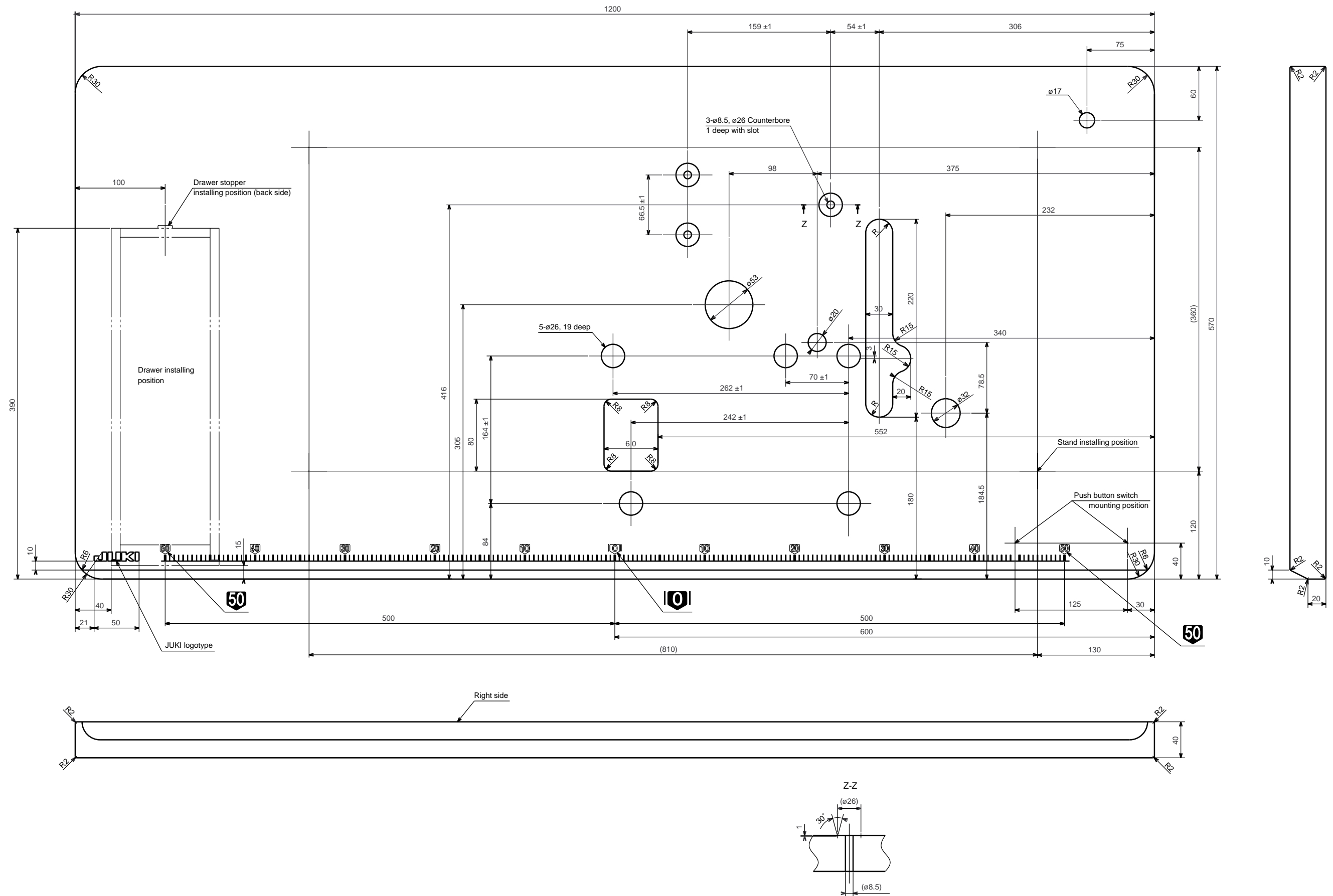

Table Part No.30148001

(5) Semi-submerged type for MFC

①

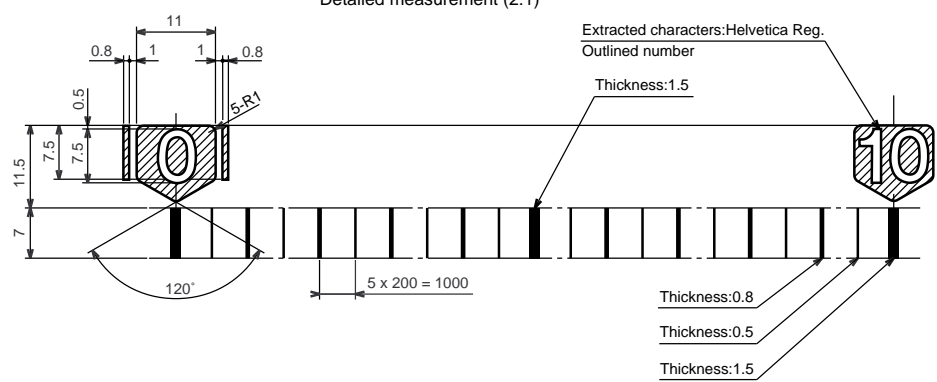
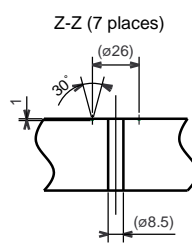
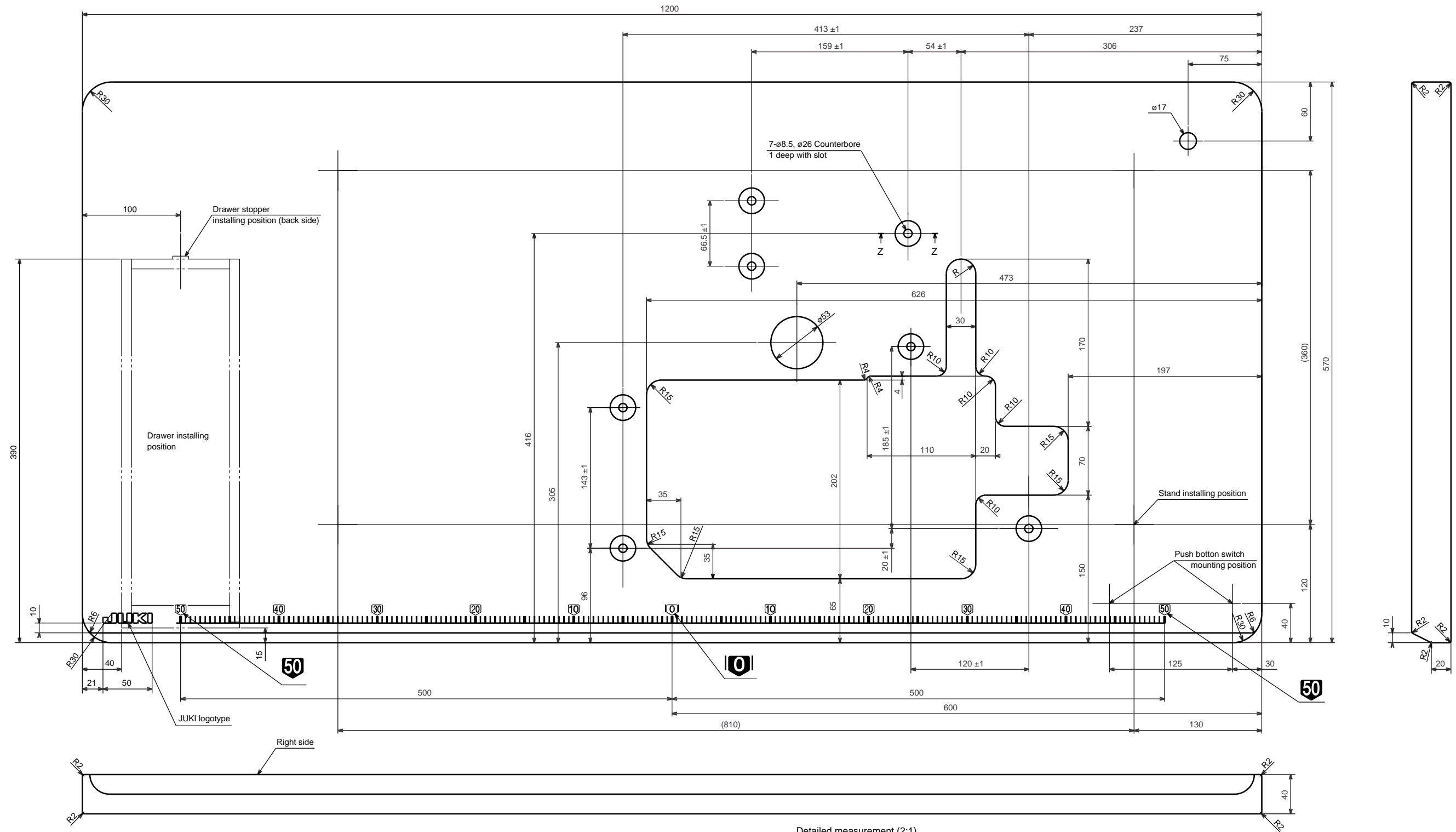
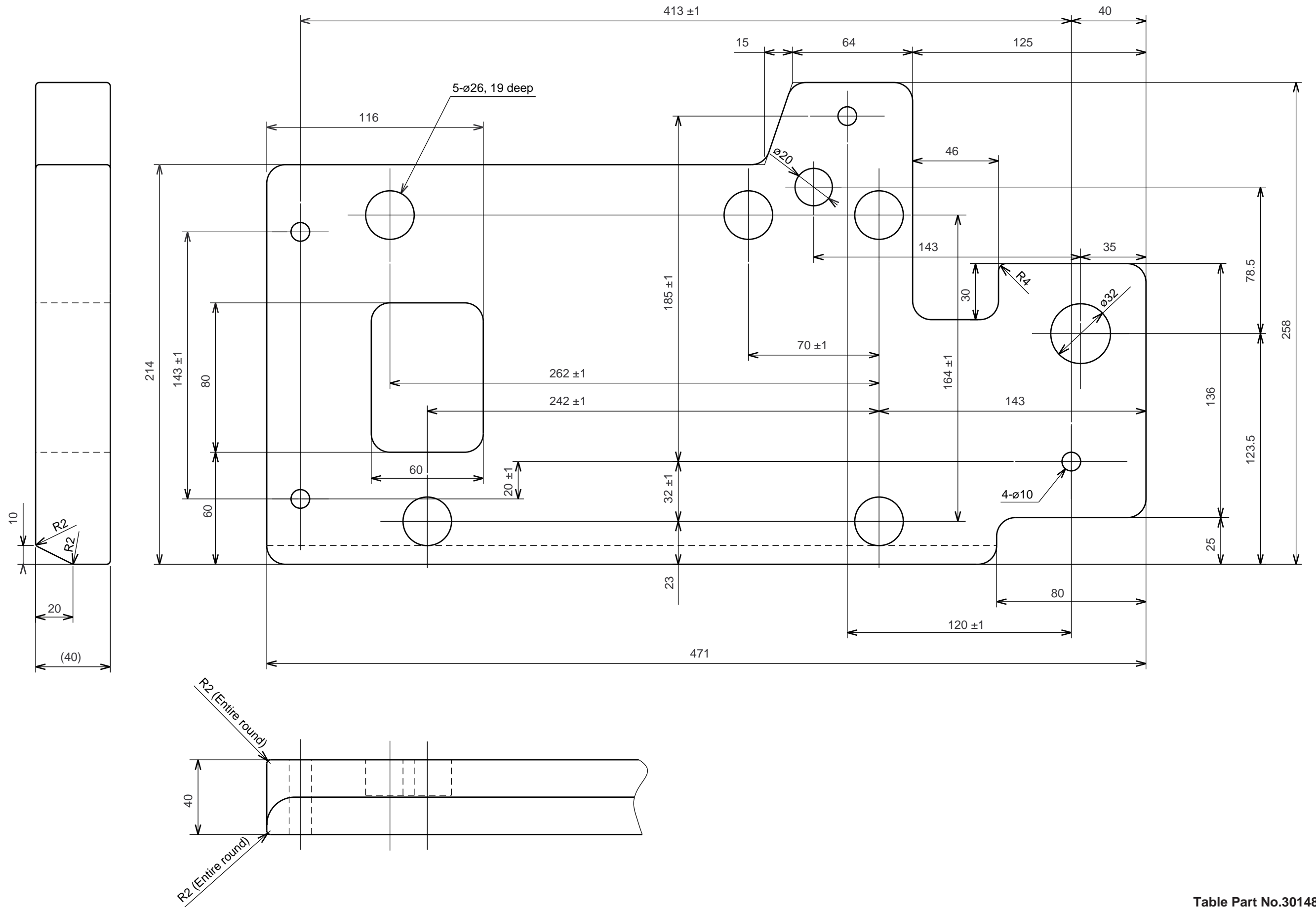

Table Part No.30148100

(6) Semi-submerged down table for MFC

②



(7) Table for MFC with tension roller

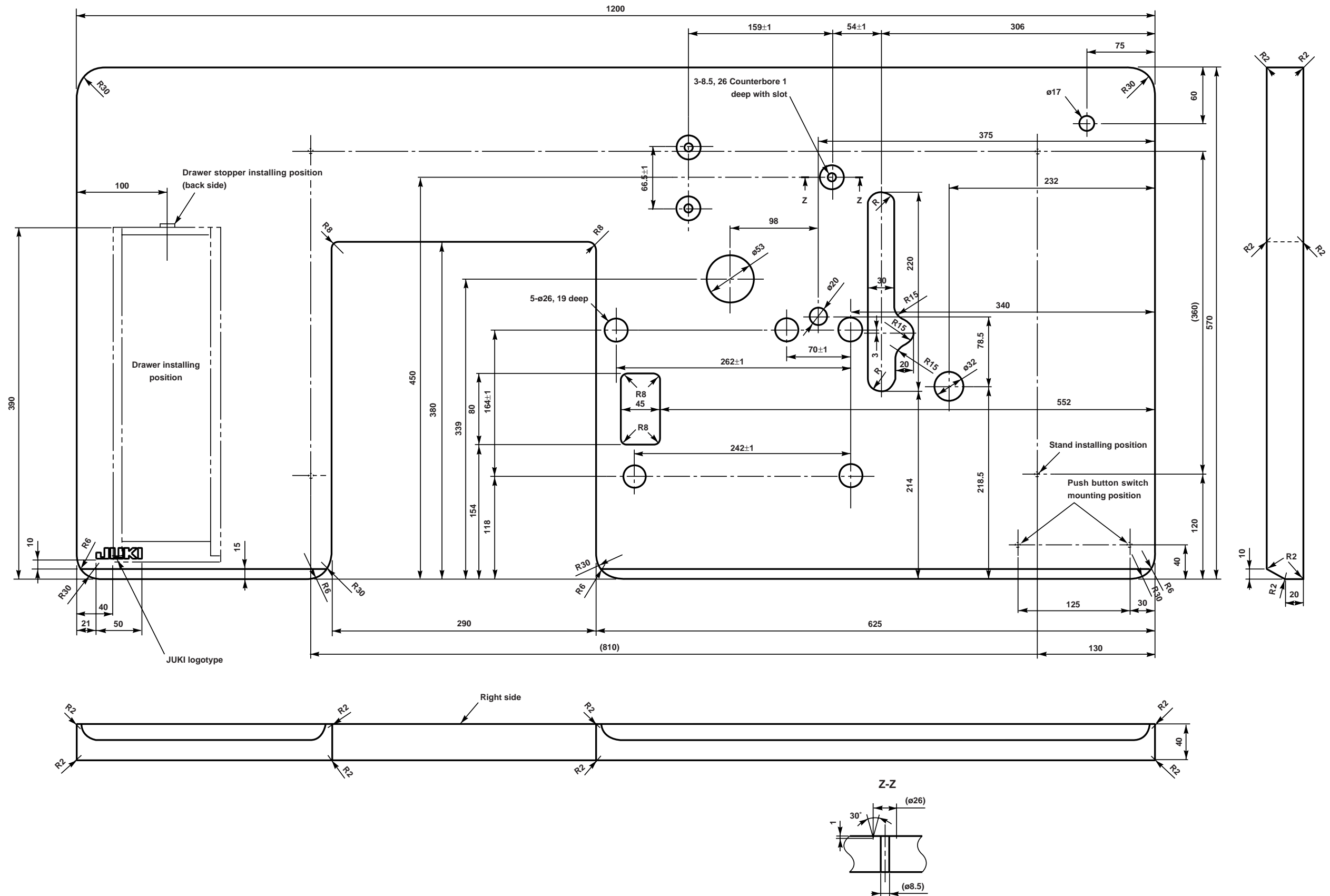

Table Part No. 19254705

JUKI®

JUKI CORPORATION

INTERNATIONAL SALES H.Q.
8-2-1, KOKURYO-CHO,
CHOFU-SHI, TOKYO 182-8655, JAPAN
PHONE : (81)3-3430-4001 to 4005
FAX : (81)3-3430-4909 • 4914 • 4984
TELEX : J22967

Copyright © 1997-2000 JUKI CORPORATION.
All rights reserved throughout the world.



Please do not hesitate to contact our distributors or agents in your area for further information when necessary.
*** The description covered in this engineer's manual is subject to change for improvement of the commodity without notice.**