

JUKI®

Dry-head Type, High-speed, Computer-controlled, Single Thread,
Chainstich Button Sewing Machine
(with Automatic Thread Trimmer and Knot-tying Mechanism)

MB-1800
MB-1800A

ENGINEER'S MANUAL

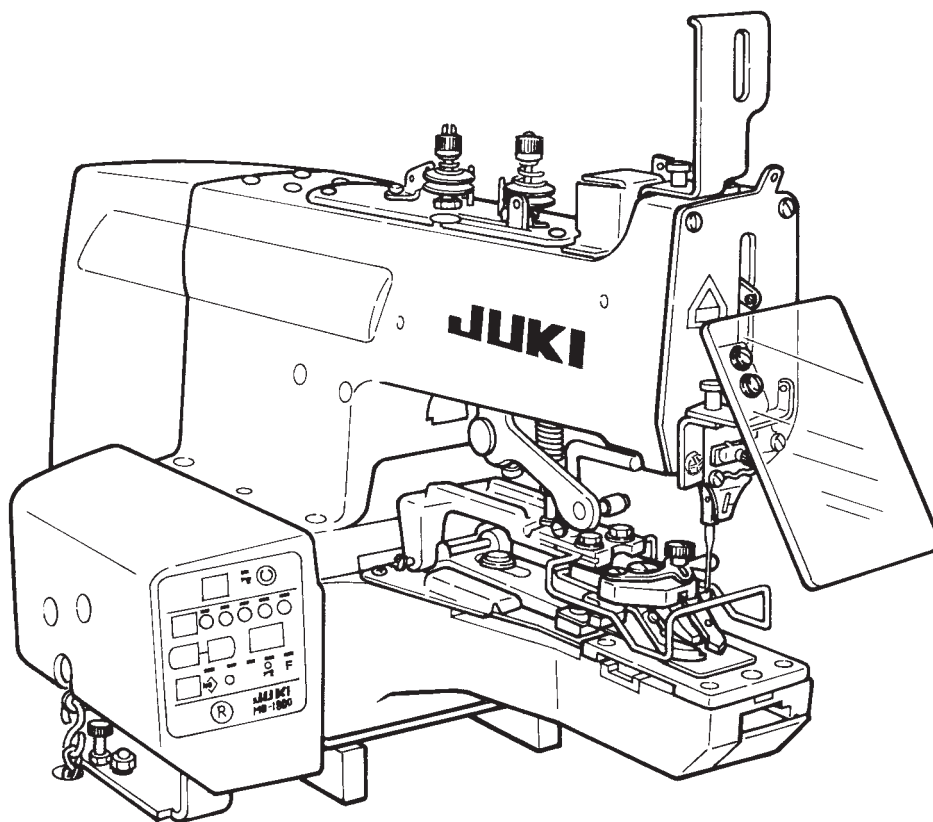

29345105
No.00

PREFACE

This Engineer's Manual is written for the technical personnel who are responsible for the service and maintenance of the machine.

The Instruction Manual for these machines intended for the maintenance personnel and operators at an apparel factory contains operating instructions in detail. And this manual describes "Standard Adjustment", "Adjustment Procedures", "Results of Improper Adjustment", and other important information which are not covered by the Instruction Manual. It is advisable to use the relevant Instruction Manual and Parts List together with this Engineer's Manual when carrying out the maintenance of these machines.

CONTENTS

1. SPECIFICATIONS	1
2. NAME OF EACH COMPONENT	2
(1) Name of the main unit	2
3. OPERATION OF THE SEWING MACHINE	3
(1) Names of the operation panel switches	3
(2) Pattern table	4
(3) How to operate and use the memory switch (User level)	5
4. STANDARD ADJUSTMENT	6
(1) Height of the needle bar	6
(2) Positioning the needle and the looper	6
(3) Timing the travel of the yoke slide	8
(4) Timing of the tension disc No. 2	8
(5) Lift and pressure of the button clamp	10
5. ADJUSTMENT OF THE THREAD TRIMMING MECHANISM	10
(1) The mechanism and the name of each component of the thread trimmer	10
(2) Adjusting the position of the moving knife	12
(3) Adjusting the height of the thread separating claw of the moving knife	12
6. PROCEDURES IN DISASSEMBLING AND ASSEMBLING	14
(1) Name of each component	14
(2) Disassembling the circuit board	16
(3) Disassembling the machine arm and bed	18
(4) Disassembling the looper shaft	20
(5) Disassembling the driving shaft	22
7. ADJUSTMENT OF THE SENSORS	26
(1) Adjusting the starting sensor	26
(2) Adjusting the presser lifter sensor	26
(3) Adjusting the feed origin sensor	28
(4) Adjusting the presser lifter stopper	28
8. HOW TO OPERATE AND USE THE MEMORY SWITCH (SERVICE LEVEL)	30
(1) Memory switch function table	31
9. HOW TO OPERATE AND USE THE INPUT CHECK MODE FUNCTION	33
(1) INPUT CHECK CORRESPONDENCE TABLE	34
10. HOW TO OPERATE AND USE THE ALL CLEAR FUNCTION	35
11. PARTS TO BE GREASESD	36
12. ERROR LIST	37
13. CHANGE-OVER OF THE POWER SOURCE VOLTAGE	38
14. CAUSE OF TROUBLES AND THE CORRECTIVE MEASURES	39
(1) Thread trimming troubles and the corrective measures	39
(2) Cause of troubles and the corrective measures for MB-1800	40
15. CIRCUIT BOARD DIAGRAM	41
(1) MAIN circuit board	41
(2) PWR circuit board	42
(3) PANEL circuit board	42
16. BLOCK DIAGRAM 1/2	43
17. CONNECTION DIAGRAM AND CIRCUIT DIAGRAM	45
(1) Power connection diagram	45
(2) Sensor connection diagram	46
(3) Motor circuit diagram	47
(4) Encoder circuit diagram	48
(5) Solenoid circuit diagram	48
18. DRAWING OF THE TABLE	49

1. SPECIFICATIONS

1) Sewing area :	X (lateral) direction 10 mm Y (longitudinal) direction 6.5 mm (0.2 mm pitch)
2) Max. sewing speed :	1,800 rpm
3) Feed motion of button clamp :	Intermittent feed (2-shaft drive by stepping motor)
4) Needle bar stroke :	48.6 mm
5) Needle :	TQx7, TQx1 (TQx7 #16 at the time of delivery)
6) Button size :	10 to 28 mm
7) Lift of button clamp :	Standard 10 mm Max. 14 mm
8) Memory of pattern data :	EEP-ROM (32K byte)
9) Enlargement/reduction system :	Increase/decrease of stitch length system
10) Limitation of sewing speed :	Sewing speed can be optionally limited to 400 to 1,800 rpm with the up/down key. (Adjustable in 100 rpm unit)
11) Pattern selection function :	1 to 99 patterns can be specified by selecting the pattern Nos.
12) Memory back-up :	In case of a power interruption, the pattern being used will be automatically stored in memory.
13) Sewing machine motor :	100W servo motor (direct-drive)
14) Dimensions of machine head :	W : 240 mm L : 550 mm H : 360 mm
15) Mass :	25 kg
16) Power consumption :	150 W
17) Operating temperature range :	5 to 35°C
18) Operating humidity range :	35 to 85% (no dew condensation)
19) Line voltage :	Rated voltage $\pm 10\%$ 50/60 Hz
20) Noise :	Workplace - related noise at sewing speed n= 1,800 min ⁻¹ : L _{PA} 80 dB(A) Noise measurement according to DIN 45635-48-B-1.

* Reduce the max. sewing speed in accordance with the sewing conditions.

2. NAME OF EACH COMPONENT

(1) Name of the main unit

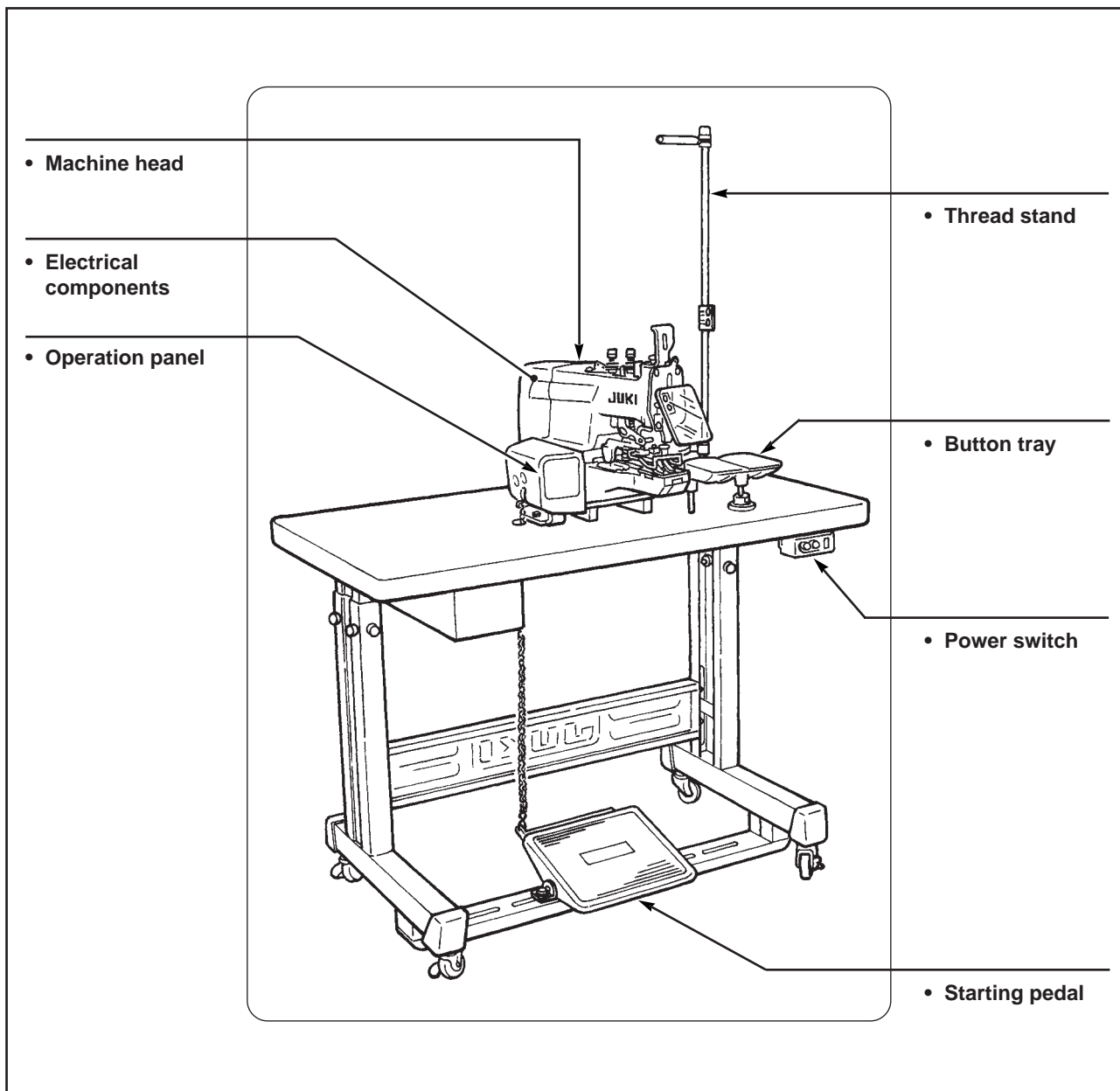

3. OPERATION OF THE SEWING MACHINE



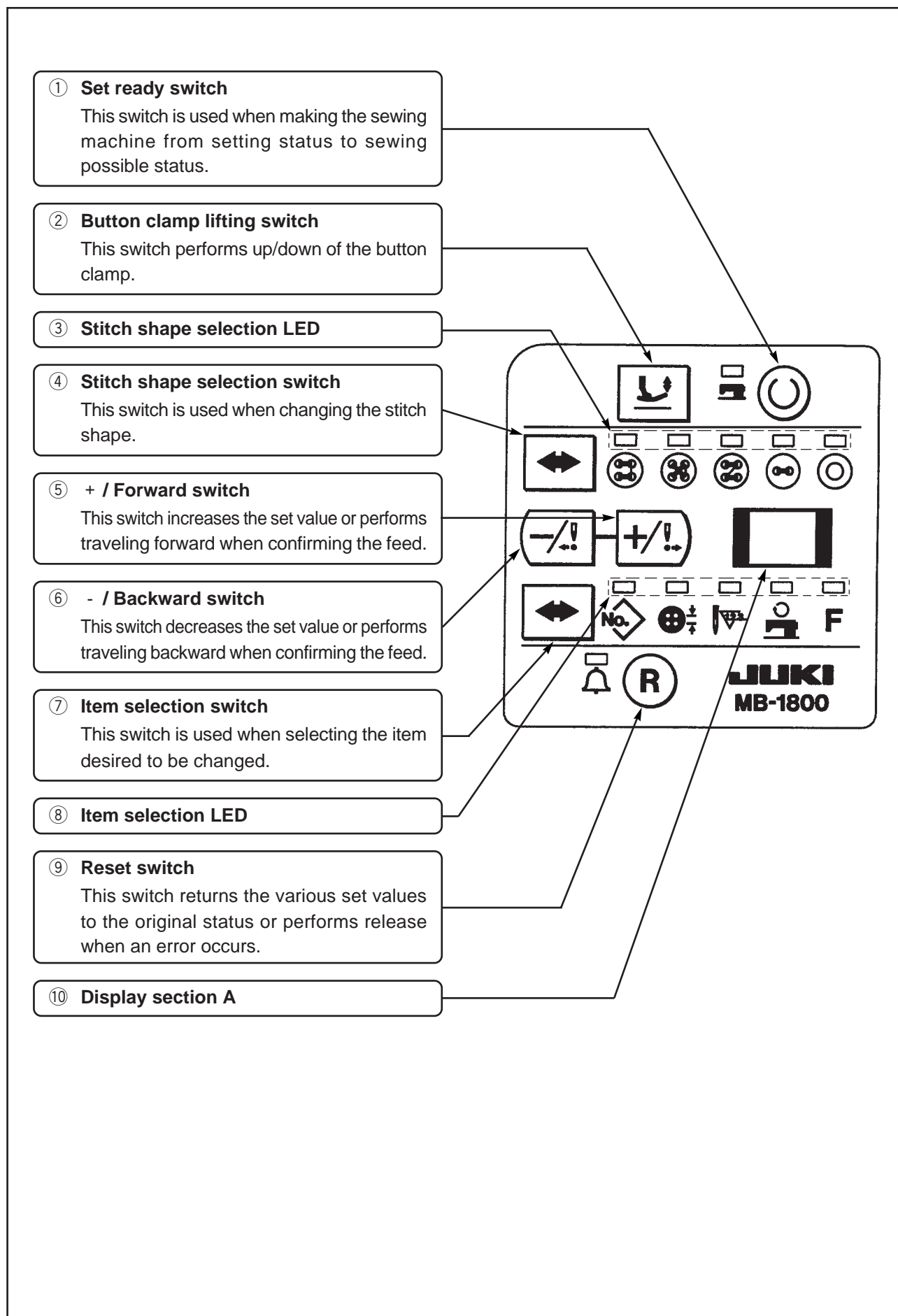











(1) Names of the operation panel switches



(2) Pattern table

Three same sewing sizes and numbers of stitches for each stitch shape have been stored in pattern Nos. 1 to 51 at the time of delivery.

By selecting sewing size and number of stitches from the table below, the stitch shape can be changed to the three different kinds of patterns of the same stitch shape and be stored in memory.

Pattern No.	Stich shape		Stich size (mm)			Number of stitches	
			Initial value	Range	Unit	Initial value	Range
1 2 3		4-holed (□, crossover stitch : with)	2.6	2.0 to 6.5	0.2	15	15, 19, 23, 27
4 5 6		4-holed (□, crossover stitch : without)	2.6	2.0 to 6.5	0.2	16	16, 20, 24, 28
7 8 9		4-holed (X, crossover stitch : with)	2.6	2.0 to 6.5	0.2	15	15, 19, 23, 27
10 11 12		4-holed (X, crossover stitch : without)	2.6	2.0 to 6.5	0.2	16	16, 20, 24, 28
13 14 15		4-holed (Z, crossover stitch : with)	2.6	2.0 to 6.5	0.2	15	15, 19, 23, 27
16 17 18		2-holed (crosswise)	2.6	2.0 to 6.5	0.2	8	8, 10, 12, 14
19 20 21		2-holed (lengthwise)	2.6	2.0 to 6.5	0.2	8	8, 10, 12, 14
22 23 24		4-holed (□, crossover stitch : with)	2.6	2.0 to 6.5	0.2	15	15, 19, 23, 27
25 26 27		4-holed (□, crossover stitch : without)	2.6	2.0 to 6.5	0.2	16	16, 20, 24, 28
28 29 30		3-holed (△)	2.6	2.6, 2.8, 3.0	0.2	17	17, 23
31 32 33		3-holed (▽)	2.6	2.6, 2.8, 3.0	0.2	17	17, 23
34 35 36		3-holed (◁)	2.6	2.6, 2.8, 3.0	0.2	17	17, 23
37 38 39		3-holed (▷)	2.6	2.6, 2.8, 3.0	0.2	17	17, 23
40 41 42		2-holed (crosswise) label attaching	10.0	6.0, 8.0, 10.0	2.0	5	5, 7
43 44 45		Wrapped-around (crosswise size : 4 mm)	2.6	0.0 to 6.5	0.2	16	6, 10, 16
46 47 48		Wrapped-around (crosswise size : 5 mm)	2.6	0.0 to 6.5	0.2	16	6, 10, 16
49 50 51		Wrapped-around (crosswise size : 6 mm)	2.6	0.0 to 6.5	0.2	16	6, 10, 16

(3) How to operate and use the memory switch (User level)

- 1) The speed up to 3rd stitch can be set so that the sewing speed at the start of sewing is controlled and the stitch is stabilized.
- 2) Effective/ineffective of the knot-tying function can be selected.
- 3) Operating/non operating of the wiper can be selected.

In case the wiper is installed and set to the non-operating setting, when the pattern without crossover thread is selected, the wiper works only when the crossover thread is trimmed, and it does not work after thread trimming at the time of completion of sewing.

In case of the pattern with crossover thread as well, the wiper does not work after thread trimming at the time of completion of sewing with this setting.

In case of the setting of operating the wiper, the wiper always works at the time of thread trimming.

① Starting of the memory switches

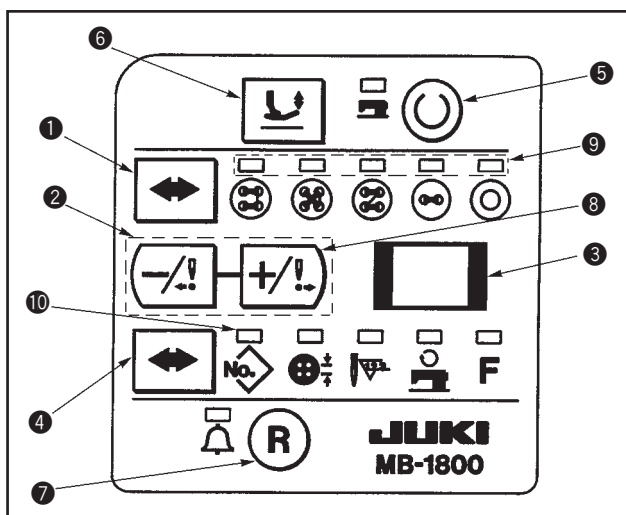

In the state that + / - switches ② are simultaneously pressed, turn ON the power, and the memory switches are in the state of setting.

At this time, "UU." is displayed in display section A ③.

Press set ready switch ⑤ and all 5 stitch shape selection LEDs ⑨ flash on and off. This state means that the memory switches are being inputted.

② Setting procedure of the memory switches

There are the memory switches 1 to 8.

Switch NO. " !" is displayed in the display section A ③ and item selection LED ⑩ of the pattern No. No. ⑩ lights up. In this state, press item selection switch ④, and the memory switch No. and the description are alternately displayed in display section A ③.

In the state that the memory switch No. is displayed, press the + switch ⑧ and the memory switch No. increases by one.

When the description of the memory switch is displayed, item selection LED ⑩ of the pattern No. No. ⑩ goes off.

Switch No.	Description	Initial setting	Setting range	Remarks
1	Speed of 1st stitch of soft start	18 * 100 [rpm]	4 to 18	400 to 1,800 rpm
2	Speed of 2nd stitch of soft start	18 * 100 [rpm]	4 to 18	400 to 1,800 rpm
3	Speed of 3rd stitch of soft start	18 * 100 [rpm]	4 to 18	400 to 1,800 rpm
4	Speed of 1st stitch after trimming crossover thread	18 * 100 [rpm]	4 to 18	400 to 1,800 rpm
5	Speed of 2nd stitch after trimming crossover thread	18 * 100 [rpm]	4 to 18	400 to 1,800 rpm
6	Speed of 3rd stitch after trimming crossover thread	18 * 100 [rpm]	4 to 18	400 to 1,800 rpm
7	Knot-tying function 0 : Ineffective 1 : Effective	1 (Operating)	0.1	
8	Wiper operation 0 : Non operating 1 : Operating	0 (Non operating)	0.1	

When setting is completed, turn OFF the power. Return ON the power to return to the normal setting state.

4. STANDARD ADJUSTMENT

Standard Adjustment

(1) Height of the needle bar

The upper engraved line of the two engraved lines for TQx1 and TQx7 should be aligned with the bottom of the lower bushing when the needle bar is at its lowest position.

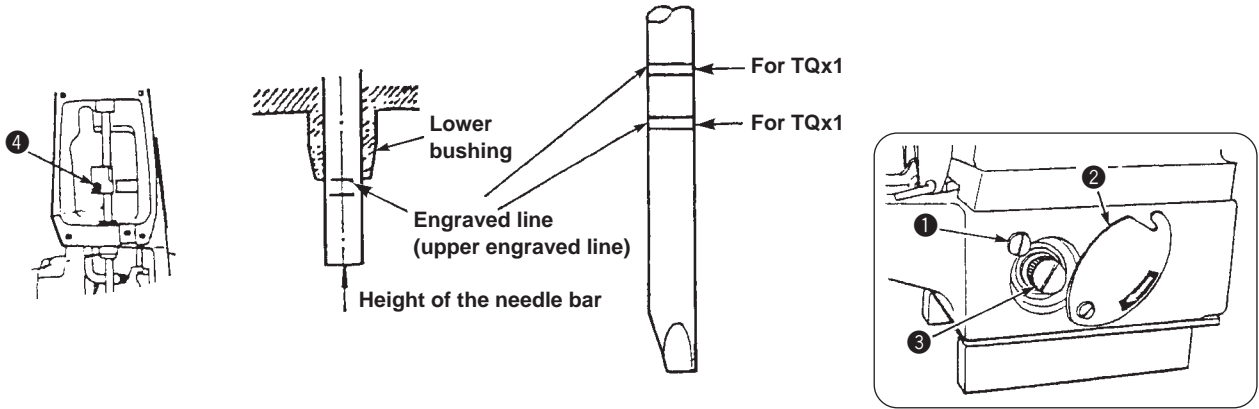

(2) Positioning the needle and the looper

1) Looper timing

When the needle bar is ascending from its lowest position and the lower engraved line on the needle bar is aligned with the bottom of the lower bushing, the looper's blade point should coincide with the center of the needle.

(When the needle bar is ascending.)

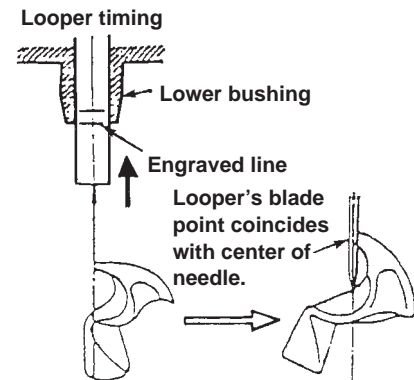

2) Clearance between the needle and looper

The clearance is 0.05 to 0.1 mm when the looper's blade point coincides with the center of the needle.

Clearance between needle and looper

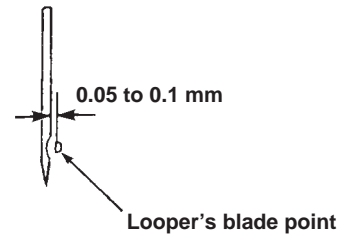

3) Clearance between the needle guide and needle

The clearance between the needle guide and needle is 0.05 to 0.1 mm when the needle bar is at its lowest position.

Clearance between needle guide and looper

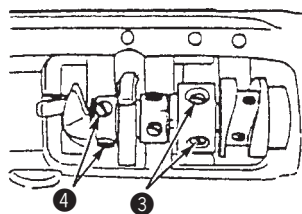
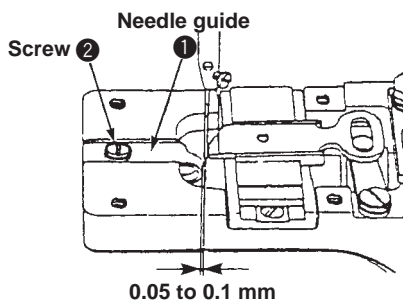

Adjustment Procedures	Results of Improper Adjustment
<ol style="list-style-type: none"> 1) Slightly loosen knob ❶ and turn cover ❷ in the direction of the arrow and you will find hand pulley ❸. 2) Turn the hand pulley by hand, loosen setscrew ❹ in the needle bar thread-take up lever and adjust so that the upper engraved line of the two engraved lines on the needle bar aligns with the bottom of the lower bushing when the needle bar is at its lowest position. 	<ul style="list-style-type: none"> ○ If the needle bar is too high, skipped stitches will be produced. ○ If the needle bar is too low, the needle will come in contact with the looper.
<ol style="list-style-type: none"> 1) Adjusting the looper timing <ul style="list-style-type: none"> ○ Loosen the two screws ❸ in the looper and cam sleeve and adjust in the rotating direction of the looper and cam sleeve so that the looper's blade point aligns with the center of the needle when the lower engraved line of the needle bar is aligned with the bottom of the lower bushing. Then tighten the screws ❸. 2) Clearance between the needle and looper <p>Loosen two screws ❹ in the looper support ring and adjust in the longitudinal position of the looper when the looper's blade point is aligned with the center of the needle. Then tighten the screws ❹.</p> 3) Clearance between the needle guide and needle <p>Loosen the screw ❷ in the needle guide ❶ and adjust in the longitudinal position of the needle guide ❶ so that the clearance between the needle guide ❶ and needle should become 0.05 to 0.1 mm when the needle bar is at its lowest position. Then tighten the screw ❷.</p> 	<ul style="list-style-type: none"> ○ If the clearance between the needle and looper is too excessive, it is likely to produce skipped stitches. If the clearance is too small, in accordance with the material used, the needle will come in contact with the looper resulting in needle breakage and looper's blade point breakage. ○ For thick materials and overlapped sections, adjust the clearance between the needle guide and needle so that the needle guide touches the needle by 0.1 to 0.2 mm.

Standard Adjustment

(3) Timing the travel of the yoke slide

1) Crosswise travel timing of the yoke slide

The height of the descending needle bar is 53 to 58 mm when the yoke slide advances and begins to travel from the right to the left (TQx7).

(In case of TQx1, 43 to 48 mm)



2) Lengthwise travel timing of the yoke slide

The yoke slide should go back immediately after the blade point of the looper has passed the thread triangle. And, it is good for the looper to go back like a slant line of the movement of the triangle.

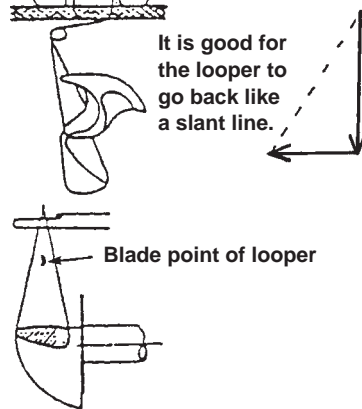

3) Lengthwise positioning of the yoke slide

Position the yoke slide so that the blade point of the looper passes through the center of the thread triangle.

(Use a 4-hole button, 9 or 10 stitches for positioning.)

(4) Timing of the tension disc No. 2

The tension disc No. 2 should float when the height of ascending needle bar becomes 54 to 57 mm.

(In case of TQx1, 44 to 47 mm)

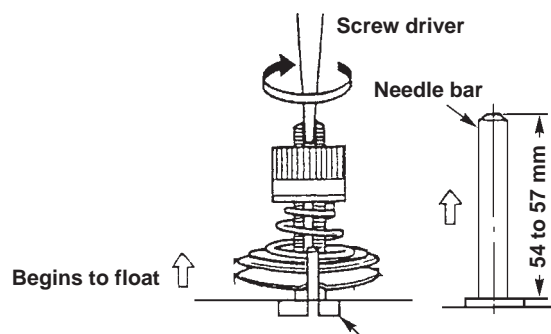

Adjustment Procedures

- For adjusting the timing of the travel of the yoke slide, align the engraved marks of the loop positioning finger cam and the triangle loop positioning finger cam with the engraved mark of the cam and looper sleeve after completing the adjustment of looper so that the engraved marks are on a straight line. Then temporarily tighten the screw.

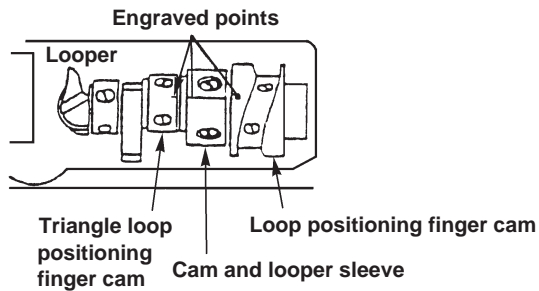

- 1) Adjust the crosswise travel timing of the yoke slide in the rotational direction of the triangle loop positioning finger cam.
When the timing is higher than 58 mm (48 mm), adjust the timing in the rotational direction of the cam. And when it is lower than 53 mm (43 mm), adjust in the reverse rotational direction.
The center of the cam is aligned with the center of the yoke slide support in the longitudinal position of the cam.
- 2) Adjust the lengthwise travel timing of the yoke slide in the rotational direction of the loop positioning finger cam.
For the triangle movement of the yoke slide, it is good for the yoke slide to go back in a slant line. When the yoke slide goes back like a swollen line, adjust the cam in the reverse rotational direction, and when it goes back like a hollow line inside, adjust the cam in the rotational direction.
- 3) Adjust the longitudinal position of the yoke slide by moving the loop positioning finger cam in the lengthwise direction.

- Loosen the adjusting nut of the tension post No. 2 and insert a screwdriver into the tension post No. 2 to adjust the timing.

The timing of the start of floating is when the thread tension is lost after passing the thread through the thread tension No. 2, holding it with fingers and turning the handwheel by ha

Timing of start of floating is when thread tension is lost at the time of needle bar ascending.

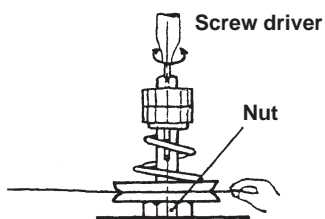

Results of Improper Adjustment

- If the triangle loop positioning finger cam begins to travel too late, thread breakage, thread remaining, balloon stitch, and insufficient tightness of stitches will result. On the contrary, if it begins to move too early, the needle will come in contact with the yoke slide.
- If the loop positioning finger cam begins to go back too early, the retreat of the yoke slide will become like a swollen line and the looper will hook the thread twice.

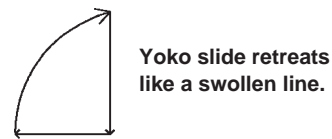

- On the other hand, if it begins to retreat too late, its retreat will become like a hollow line and the needle will come in contact with the yoke slide.

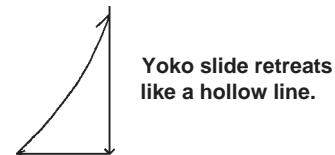

- If the longitudinal position of the yoke slide is improper, the looper will hook the thread twice or the needle will come in contact with the yoke slide.

- If the thread tension is released too early, thread remaining and/or poor tightness of stitches will result.

On the other hand, if the timing of thread tension release is too late, thread will break.

Standard Adjustment

(5) Lift and pressure of the button clamp

1) Lift of the button clamp

Ⓐ Standard : 12 mm

Max. : 9 mm

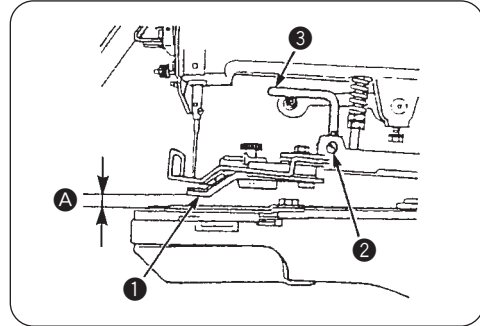

2) Pressure of the button clamp

Adjust the position of the pressure adjusting nut to 4 to 5 mm.

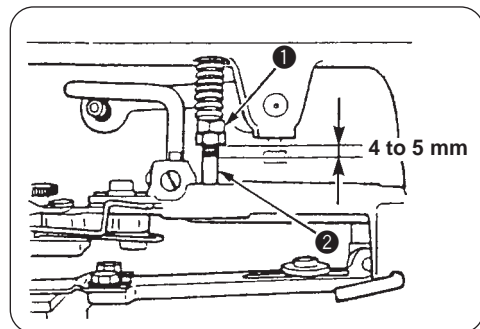

5. ADJUSTMENT OF THE THREAD TRIMMING MECHANISM

(1) The mechanism and the name of each component of the thread trimmer

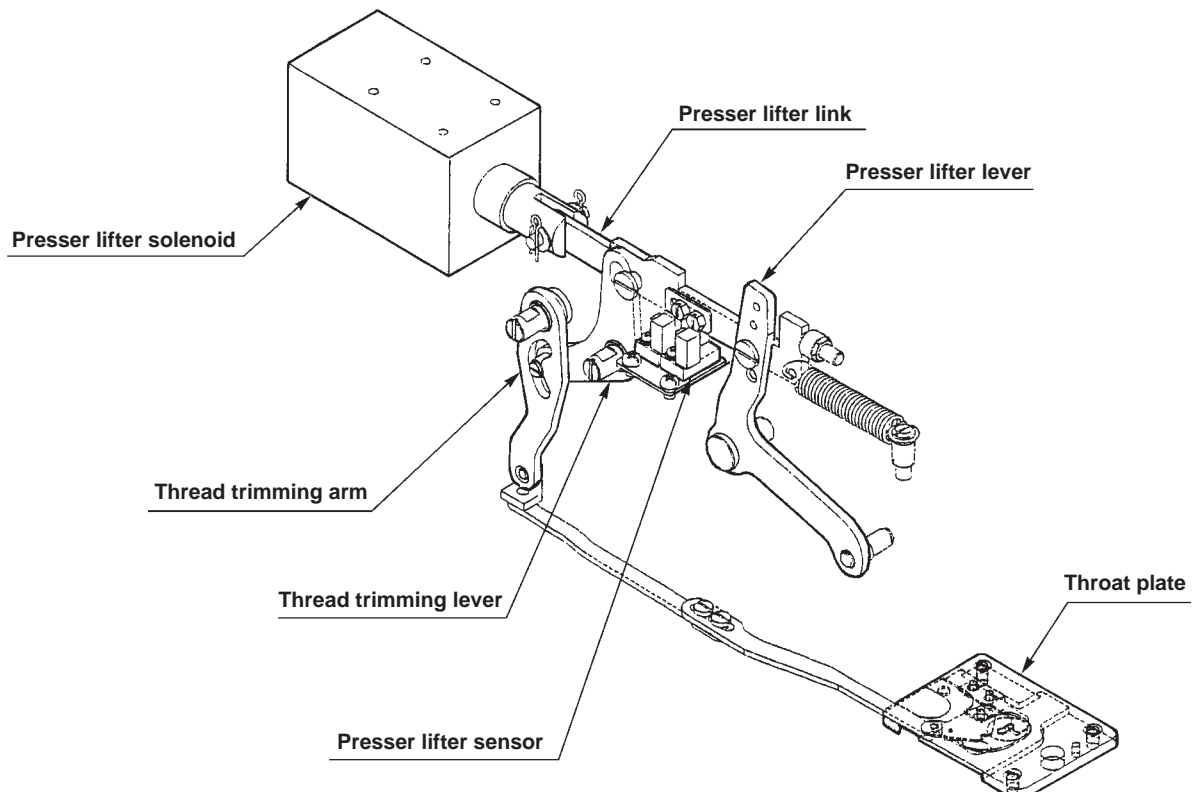

Adjustment Procedures	Results of Improper Adjustment
<p>1) The knife moves in accordance with the lifting of the button clamp. Therefore, the length of the remaining thread on the wrong side of a fabric depends upon the height of the button clamp at which the thread is trimmed.</p> <p>For the adjustment, insert something of 10 mm thick into section A and make a state that button clamp jaw levers 1 are lifted .</p> <p>Loosen screw 2 and tighten screw 2 to fix the button clamp in the state that lifting hook 3 is pressed to the lower side.</p> <p>2) Make adjustment by turning the pressure adjusting nut 1.</p>	<ul style="list-style-type: none"> ○ Increasing the lifting amount of the button clamp will increase the length of the remaining thread. Especially in case of MB-372, thread tightness becomes strong at the end of sewing resulting in thread breakage and thread slip-off. ○ If the lifting amount of the button clamp is too low, the length of the remaining thread will become short resulting in thread slip-off. ○ If the pressure of the button clamp is too low, the thread end at the start of sewing will come out on the wrong side of the fabric unevenly by 10 to 20 mm.

--	--

Standard Adjustment

(2) Adjusting the position of the moving knife

Adjust the position so that the distance between the thread trimming connecting plat (front) and the edge of the slot in the throat plate should be 12 to 13 mm when the button clamp is at its highest position.

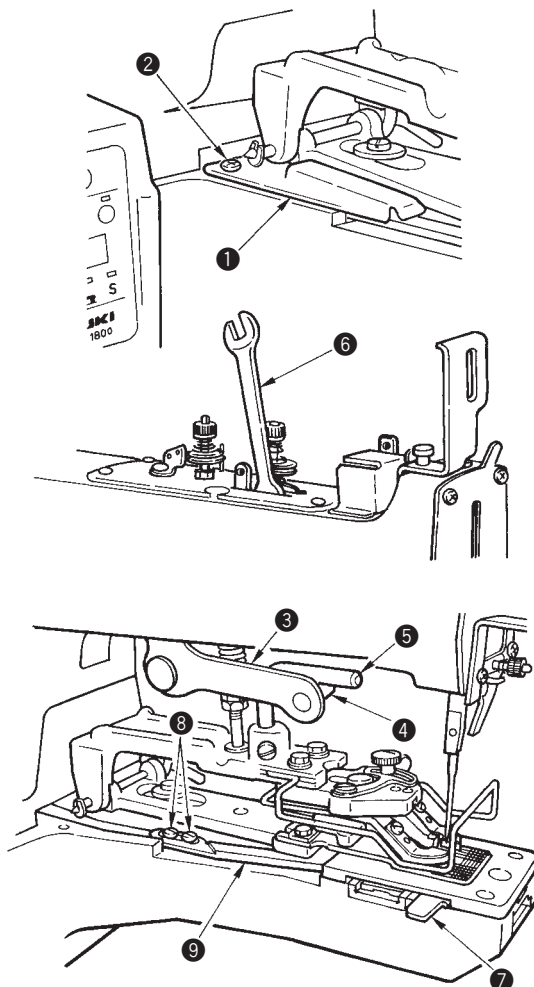

(3) Adjusting the height of the thread separating claw of the moving knife

Make adjustment so that the clearance between the thread separating claw ① and the looper ② should become 0.5 to 0.7 mm.

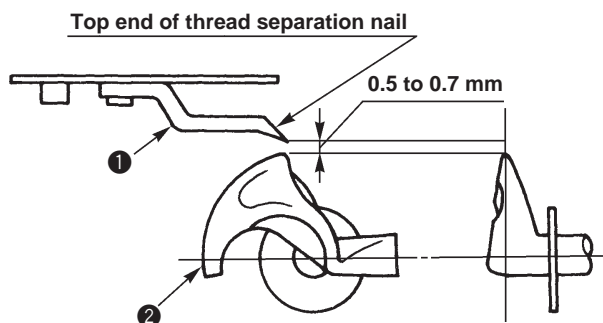

Adjustment Procedures	Results of Improper Adjustment
<ol style="list-style-type: none"> 1) Remove cover ❶ with setscrew ❷. 2) In order to place thread trimming connecting plate A ❸ to the most advanced position, lift the presser lifter lever to such an extent that roller ❹ and hook ❺ of presser lifter lever ❸ come in contact with each other and insert spanner ❻ as shown in the figure on the left. 3) Insert gauge ❼ into the end face of the throat plate groove, loosen screws ❽, make the top end of thread trimming connecting plate A ❸ come in contact with gauge ❼, and tighten screws ❾. 	<ul style="list-style-type: none"> ○ If this dimension is excessively large, the thread trimming timing is delayed and the remaining thread on the wrong side of cloth is lengthened. If the dimension is excessively small, the thread trimming timing becomes too early, thread trimming failure such as poor tightness of stitches (easily frayed) at the last stitch, simultaneous thread trimming of two threads due to the failure of thread separation, no thread trimming, etc. is apt to occur.
<ul style="list-style-type: none"> ○ Make adjustment by bending the thread separating claw ❶. 	<ul style="list-style-type: none"> ○ If the thread separating claw is too high, the claw may fail to separate the thread on the needle from that on a fabric. As a result, thread may not be trimmed, or the both threads are trimmed together, causing thread slippage from the needle in the subsequent stitching start.

6. PROCEDURES IN DISASSEMBLING AND ASSEMBLING

Procedures in disassembling and assembling

(1) Name of each component

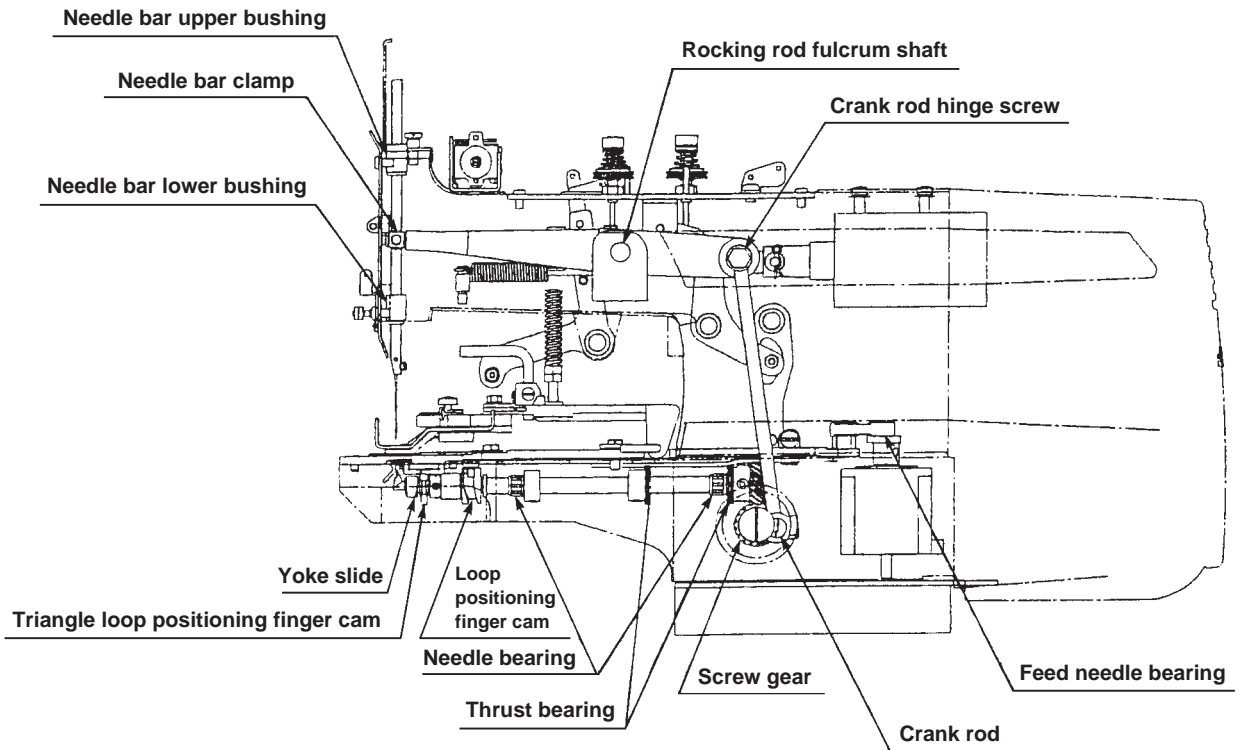

Cautions in disassembling	Cautions in assembling

Procedures in disassembling and assembling

(2) Disassembling the circuit board

1) Cover components

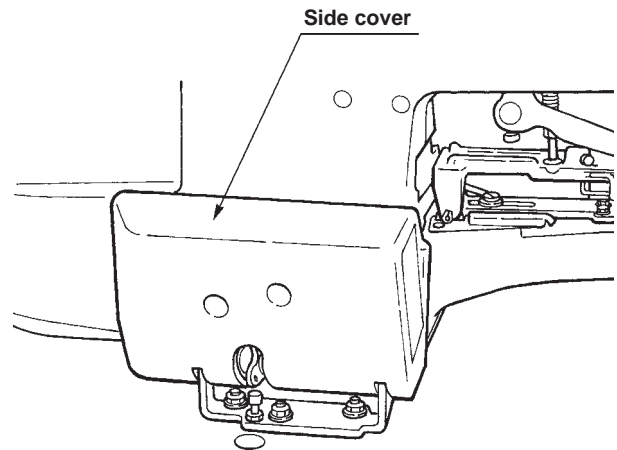
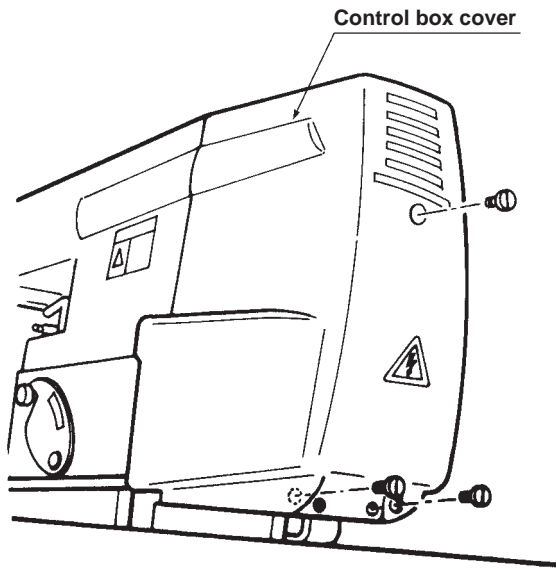

2) Circuit board components

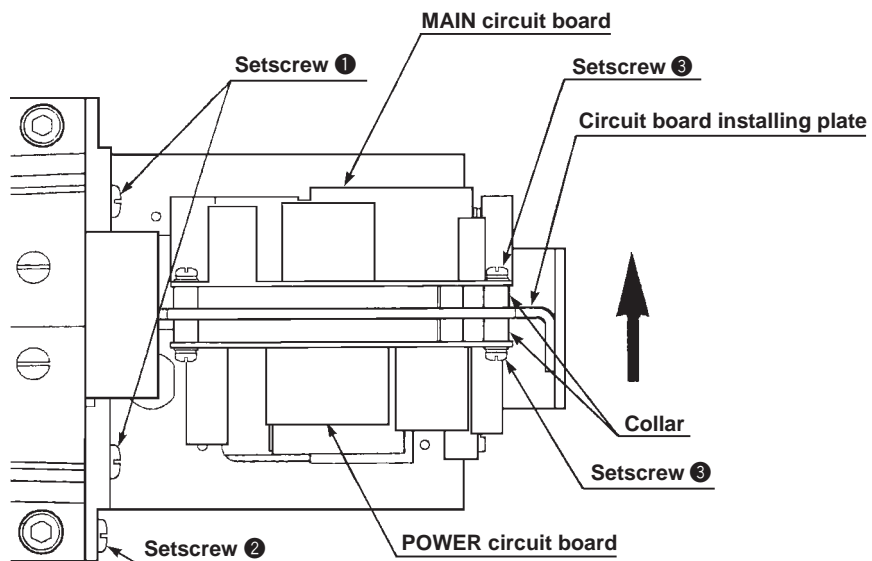
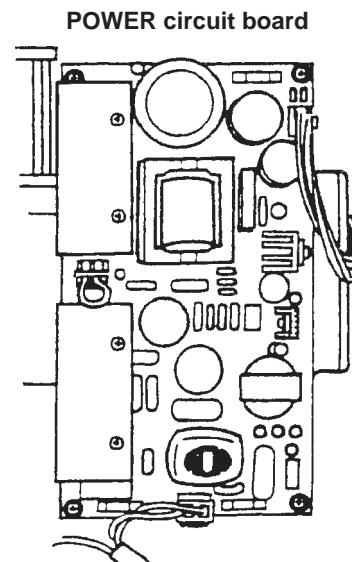
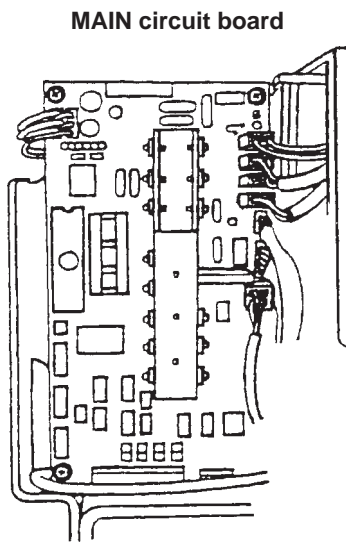

Cautions in disassembling	Cautions in assembling
<p>Disassembling and assembling of the circuit board</p> <p>Disassembling</p> <ol style="list-style-type: none"> 1) Remove the control box cover and the side cover. Remove all connectors connected to the circuit board. 2) Loosen setscrews ❶ by 2 to 3 mm. 3) Remove setscrews ❷, hold the circuit board installing plate by hand and draw it out in the direction of the arrow and you can remove the circuit board in the state that it is connected to the circuit board installing plate. 4) Remove 8 setscrews ❸, and MAIN circuit board and POWER circuit board can be removed. 	<p>Assembling</p> <ol style="list-style-type: none"> 1) Assemble in the order of MAIN circuit board, collar, circuit board installing plate, collar and POWER circuit board.

Procedures in disassembling and assembling

(3) Disassembling the machine arm and bed

1) Bed components

- Rubber base

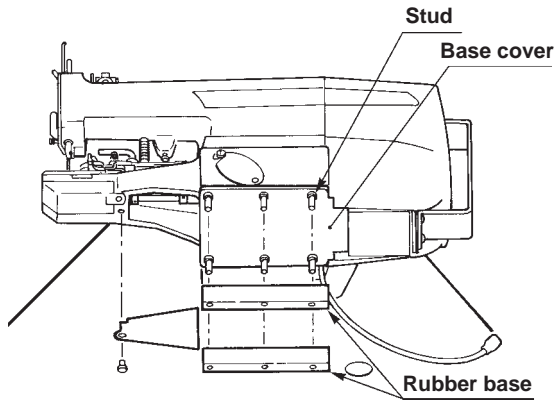

- Crank rod

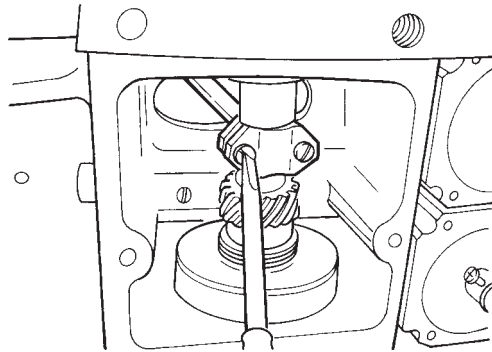

- Starting spring

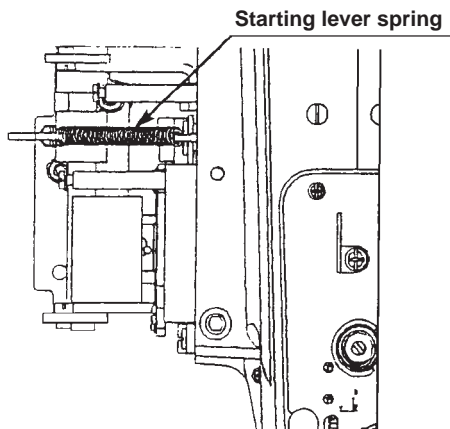

- Throat plate

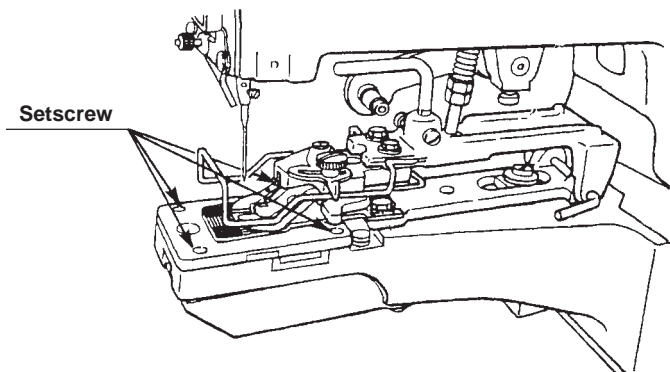

2) Arm components

- Bed connecting bolt

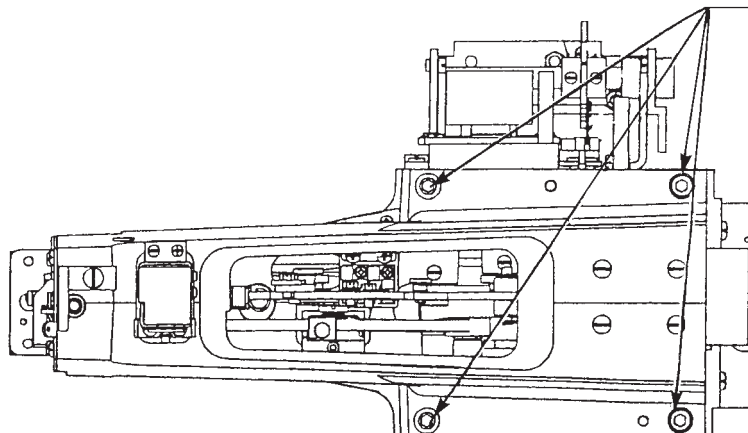

Cautions in disassembling

Disassembling and assembling the machine arm and bed
Disassembling

(Note) When disassembling the machine arm and bed, remove the whole set of the circuit board. For removing procedure of the circuit board, see the item "Disassembling the circuit board" P.16.

- 1) Tilt the machine head, remove the rubber base, stud and setscrews, and remove the cover and packing.
- 2) Remove the screws in the crank rod.
- 3) Again, directly attach four studs to the machine bed and place the rubber base.
- 4) Raise the machine head, loosen four setscrews in the throat plate and remove the throat plate.

(Note) At this time, if the screws in the thread trimming connecting plate are removed, it is necessary to again adjust the position of the moving knife when assembling.

- 5) Remove the starting lever spring.
- 6) Remove the arm/bed connecting bolts and remove the machine arm while rocking and lifting it. Finally, remove the knock pins.

Cautions in assembling

Assembling

- 1) Hold the machine arm and place it on the surface of the machine bed so that the thread trimming connecting plate and the crank rod are placed in the predetermined positions on the machine bed.
- 2) After entering the knock pins and determining the position, enter the connecting bolts to fix the machine arm.
- 3) Hook the starting lever spring.
- 4) Install the throat plate.
- 5) Tilt the sewing machine, remove the rubber base and studs, enter the base cover and packing and again assemble it. At this time, move the sensor slit attached to the stepping motor to the position as shown in the figure below.
- 6) Raise the sewing machine and assemble the circuit board. Refer to the item of "Circuit board" P.16.

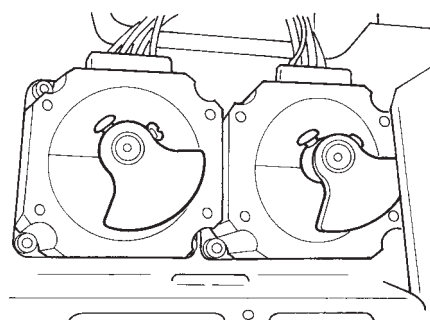
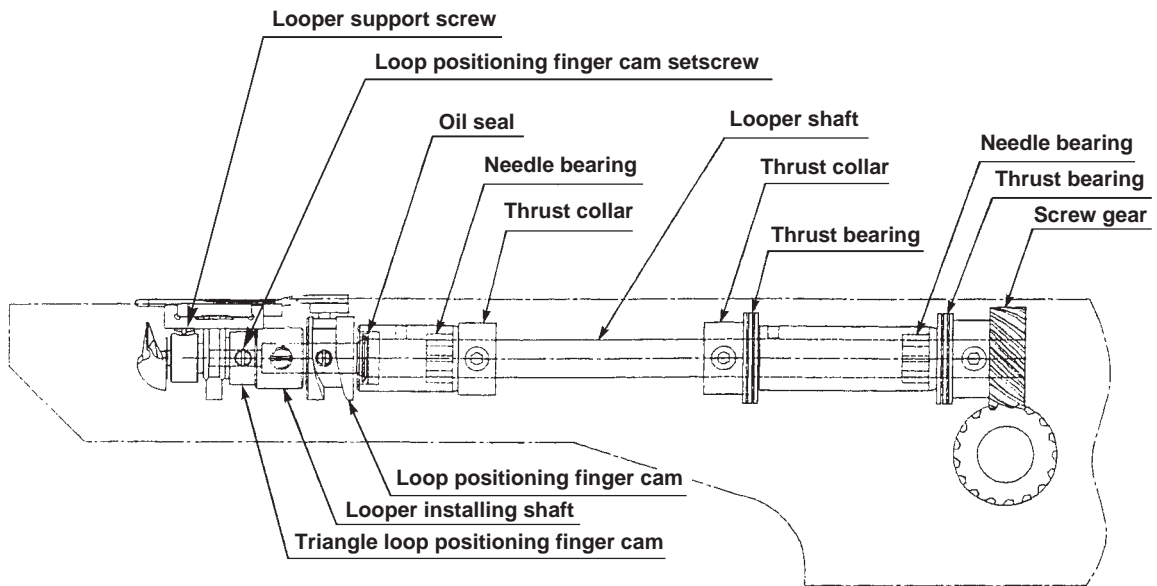

Fig.

Procedures in disassembling and assembling

(4) Disassembling the looper shaft

1) Disassembling



2) Screw gear components

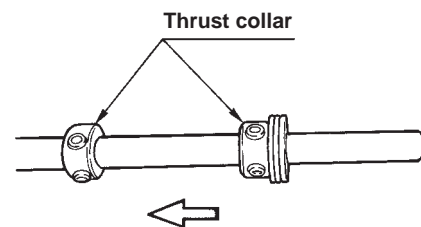
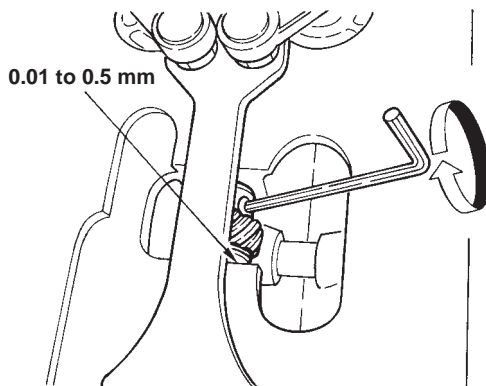

3) Adjustment

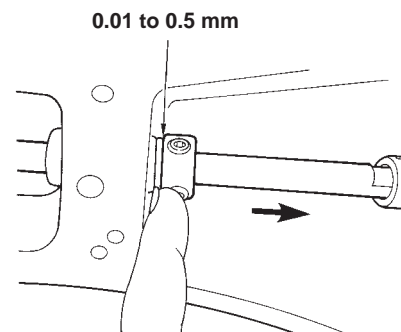
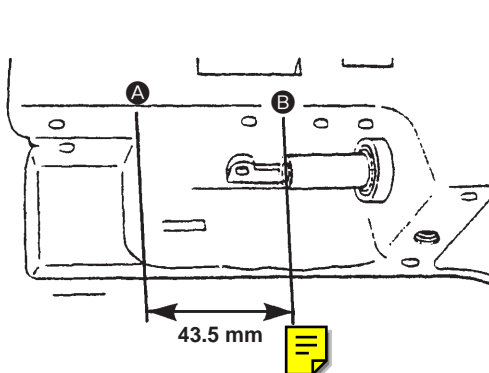

Cautions in disassembling	Cautions in assembling
<p>Disassembling and assembling the looper shaft</p> <p>Disassembling</p> <ol style="list-style-type: none"> 1) Disassemble the machine arm and bed. Refer to the item "Disassembling the machine arm and bed" P.18. 2) Remove the throat plate and remove the components related to the yoke slide and the looper. (Same components as those of MB-373) 3) Loosen the setscrews of the screw gear and tilt the machine bed. 4) Loosen the setscrews of the thrust collars and draw out the looper shaft in the direction of the arrow mark (↔). 	<p>Assembling</p> <ol style="list-style-type: none"> 1) Fully apply grease to the inside of the bushing. (It is not necessary when filling grease with grease gun or the like from the grease hole on the surface of the machine bed after setting up.) 2) Enter two thrust collars and the screw gear on the looper shaft. 3) Fit the thrust collars at the position where the dimension from section A to top end B of looper shaft is 43.5 mm.  4) The thrust collar in the front side is for prevention of slip-off of the needle bearing. Press the looper shaft backward (in the direction of the arrow ➡) and fix it so that a clearance of 0.1 to 0.5 mm is provided between the thrust collar and the bushing. 5) Raise the sewing machine and tighten the screw gear. At this time, adjust the thrust play of the looper shaft to 0.01 to 0.5 mm. 6) Assemble the components related to the looper and the yoke slide. (Same adjustment as that of MB-373)

Procedures in disassembling and assembling

(5) Disassembling the driving shaft

• **Disassembling**

- 1) For the removing procedure of the circuit board, base cover and crank rod, see P.18.
- 2) Bushing and stator setscrew

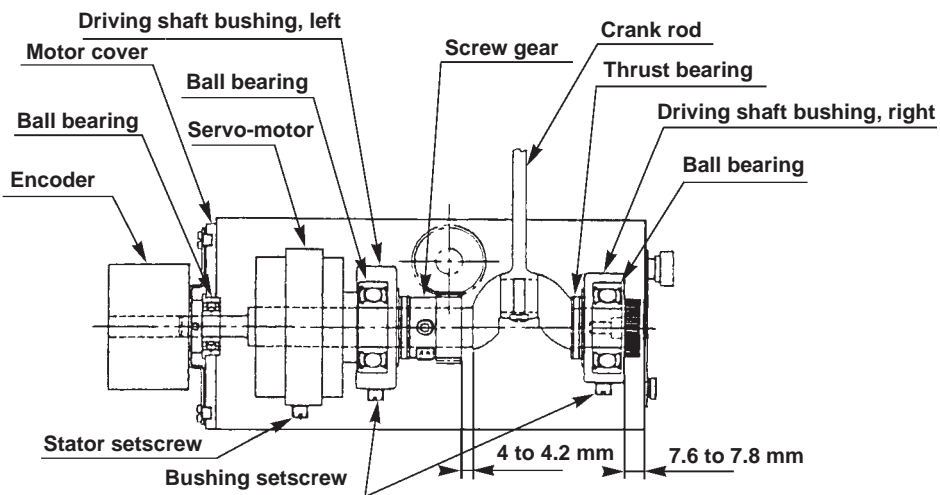

4) Motor cover

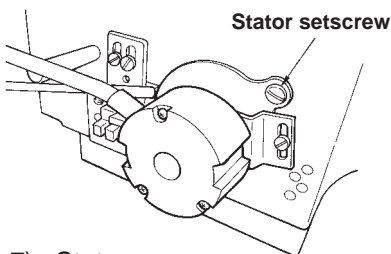

5) Driving shaft (asm.)

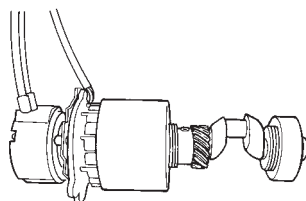

6) Encoder

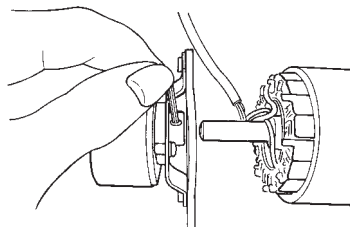

7) Stator

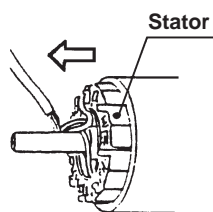

8) Rotor

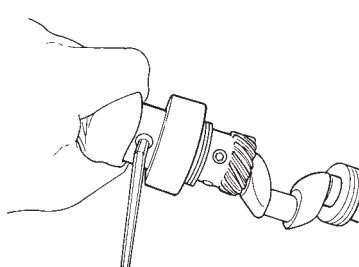

9) Setscrew and bushing of screw gear

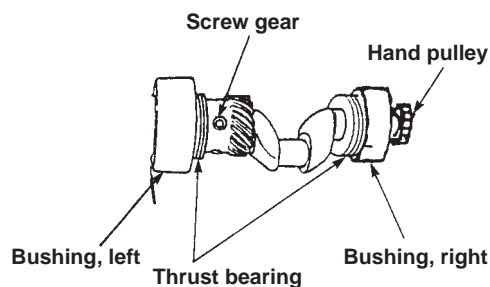

• **Assembling**

1) Screw gear

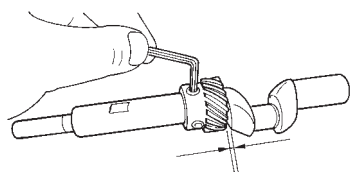

4) Rotor

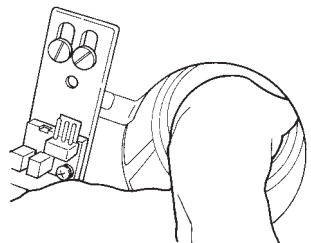

5) Stator

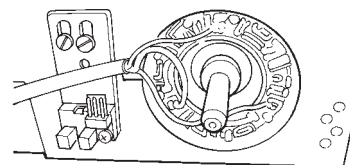

8) Bushing

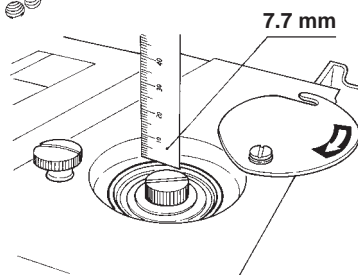
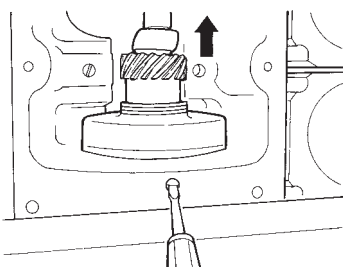

Cautions in disassembling	Cautions in assembling
<p>Disassembling and assembling of the driving shaft (Note) Do not disassemble the driving shaft except when it has broken since since the motor is built in.</p> <p>Disassembling * * Prepare before disassembling a clean board which is not affected by magnetism and a piece of clean cloth so that the rotor is not directly touched by hand.</p> <ol style="list-style-type: none"> 1) Remove the circuit board. See the item "Circuit board" P.16. Tilt the sewing machine, remove the base cover and remove the setscrews in the crank rod. 2) Loosen setscrews in the bushing, setscrews in the stator and loosen the hand pulley. 3) Assemble again the studs and the rubber base, and raise the sewing machine. 4) Remove setscrews in the motor cover and draw out the whole driving shaft. 5) Put the driving shaft which has been drawn out on a clean board which is not affected by magnetism. <p>* * Once again pay attention to the following matters before disassembling the driving shaft which has been drawn out.</p> <ol style="list-style-type: none"> ① Check whether there is anything such as iron powder or the like which is attracted by the magnet in the neighbourhood. ② Check whether there is any electronic apparatus which is easily affected by the magnetism. ③ Prepare a piece of clean cloth to wrap the rotor. ④ Wash the hands to make them clean. <ol style="list-style-type: none"> 6) Loosen setscrews and draw out the encoder together with the motor cover. 7) Draw out the stator from the driving shaft. Pressing the driving shaft, slowly draw out the stator with force on the board since the stator is pulled by the strong magnetism from the rotor located inside the stator. <p>(Note) If the force is quickly applied, the stator and the rotor come off suddenly at the position where the magnetism is lost. As a result, the parts may be dropped. So, be careful.</p> <ol style="list-style-type: none"> 8) Hold the rotor so that it is wrapped in a piece of clean cloth, loosen the setscrew, and draw it out from the driving shaft. Wrap the rotor which has been drawn out in a piece of cloth. <p>(Note) The black section of the rotor is a strong magnet. If there is a screwdriver or a screw in the neighbourhood, it is attracted to the manet with force. As a result, it may be broken by the shock. So, be careful.</p> <ol style="list-style-type: none"> 9) Loosen the setscrew in the screw gear, and remove bushings, right and left, thrust bearing and hand pulley. 	<p>Assembling</p> <ol style="list-style-type: none"> 1) Install the screw gear. (Clearance : 4 to 4.2 mm) 2) Enter the thrust bearing and the bushings, and install the hand pulley. 3) Install the rotor. Hold it so that the screw section comes out and install it so that there is no clearance in the thrust direction. 4) In this state, enter the rotor in the machine bed. Do not take the cloth covering the rotor. 5) Next, enter the stator. Set the direction of the cord as shown in the figure and slowly enter the stator while pressing the driving shaft. When the magnetism of the rotor works, the stator enters with force as if it is absorbed. On the contrary, the driving shaft tries to jump out. Accordingly, hold the driving shaft by hand. 6) Install the motor cover. Keep the setscrew in the encoder held loosened. 7) Tilt the sewing machine. 8) First, determine the position of the bushing on the right-hand side. Fix it so that the dimension from the end face of the machine bed is 7.7 mm. 9) Next, fix the bushing on the left-hand side while making the driving shaft come in contact with the bushing on the right-hand side. 10) Fix the crank rod. 11) Remove the studs and the rubber base and again assemble them together with the base cover and the packing. At this time, move the sensor slit attached to to the stepping motor. For the position of the sensor slit, refer to the figure on P.19.

Procedures in disassembling and assembling

(5) Disassembling the driving shaft

- Assembling and adjusting procedure of the servo-motor

15) Stator setscrew

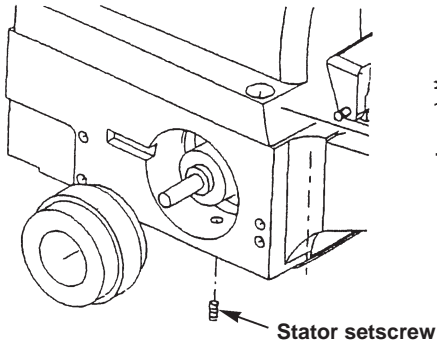

16) Cord outlet

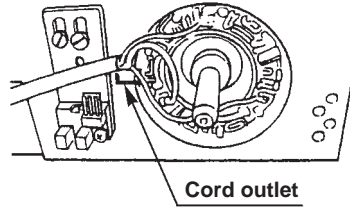

17) Operation panel

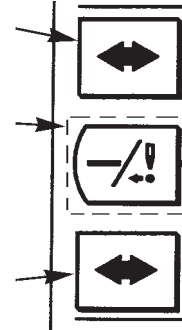

18) Panel display

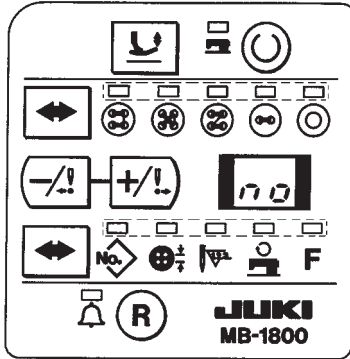

20) Fixing stator

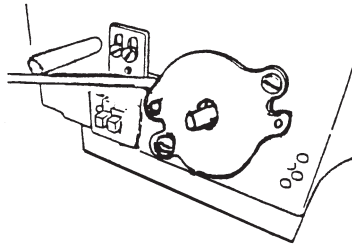

21) Encoder

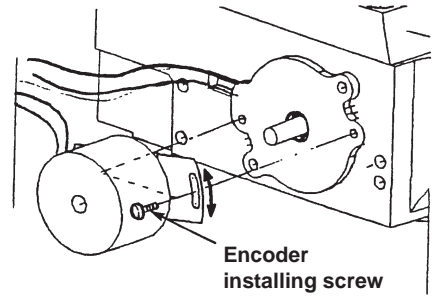

23) Encoder setscrew

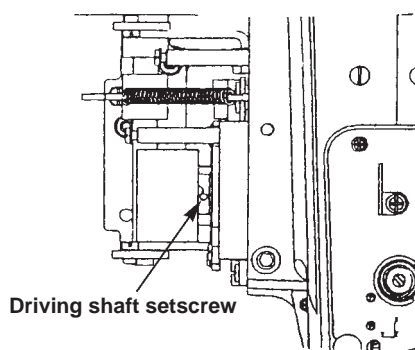

24) Encoder "0" display

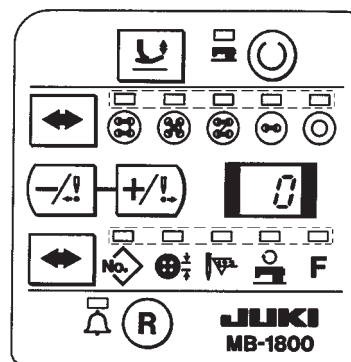

Cautions in disassembling	Cautions in assembling
	<p>12) Raise the sewing machine and install the circuit board. Refer to the item "Circuit board". P.16.</p> <p>13) Connect all connectors with the side cover removed and install the control box cover.</p> <p>14) Tilt the sewing machine. Turn the hand pulley to bring the needle bar to its lowest position.</p> <p>15) Check that the stator setscrew is loosened.</p> <p>16) Enter the stator cord so that it comes to the cord outlet. At this time, do not fix the stator.</p> <p>17) Pressing three buttons (arrow mark, "-", and arrow mark from the top) located on the left end of the operation panel, turn ON the power.</p> <p>18) [no] is displayed in the display section of the operation panel.</p> <p>19) In this state, the stator is in the excitation mode, and the rotor and the stator are fixed. At this time, "W" phase and "V" phase of the rotor are excited. Excitation duty is 20% and current value is approximately 4 [A].</p> <p>20) In this state, turn again the hand pulley and adjust so that the needle bar is brought to its lowest position. Fix the stator in this state. The rotor and the stator have come to the most proper position since they are pulling each other.</p> <p>21) Raise the sewing machine. Enter the hexagonal wrench key when the encoder setscrew is at the position as shown in the figure. (Encoder should be temporarily tightened in the center of the slot.)</p> <p>22) Pressing the three buttons located on the left side of the operation panel, turn ON the power.</p> <p>23) Loosen the driving shaft setscrews of the encoder and fix them at the position where the setscrew No. 1 comes almost just above. (The position just above overlaps with the encoder screw. Tighten the screw at the slightly front side.) Hand tightening</p> <p>24) Loosen the encoder setscrews, adjust the position to "0" while observing the operation panel. Then tighten the setscrews. (The value varies -9 to +9.) 20 to 40 kgf</p> <p>25) Turn OFF the power and install the side cover.</p> <p>26) Tighten the stator setscrew.</p>

7. ADJUSTMENT OF THE SENSORS

Standard Adjustment

(1) Adjusting the starting sensor

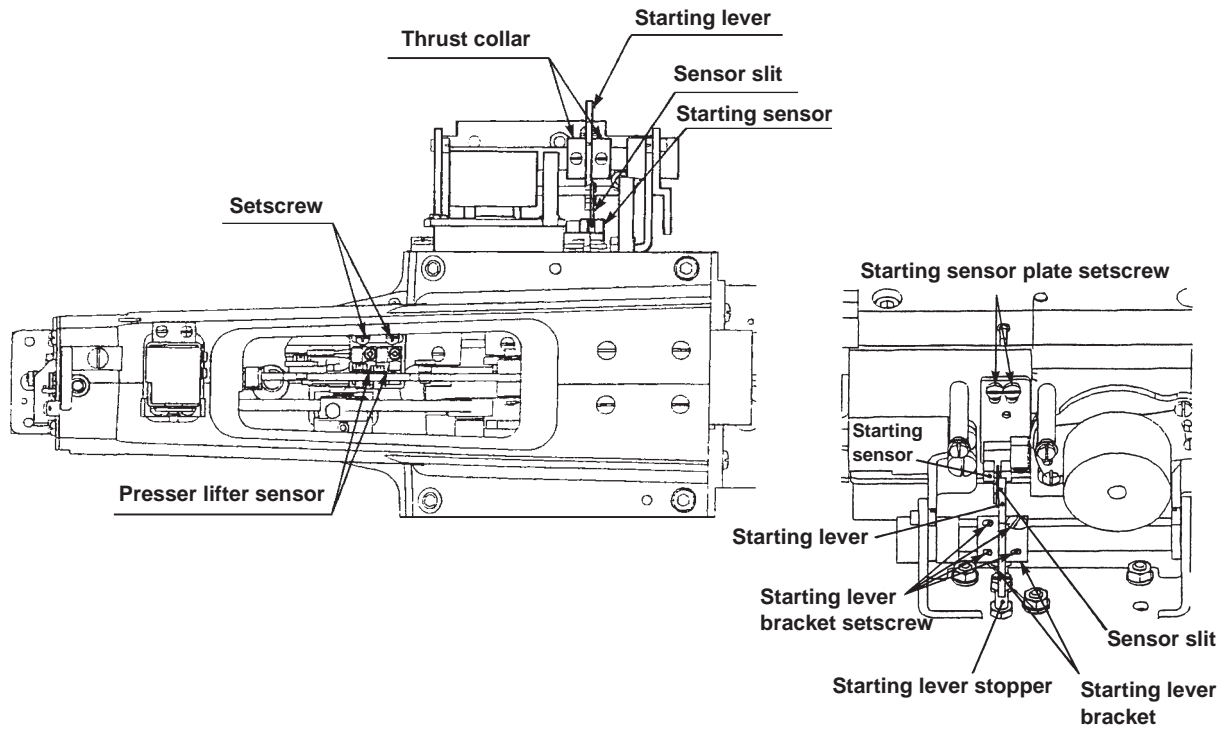

(2) Adjusting the presser lifter sensor

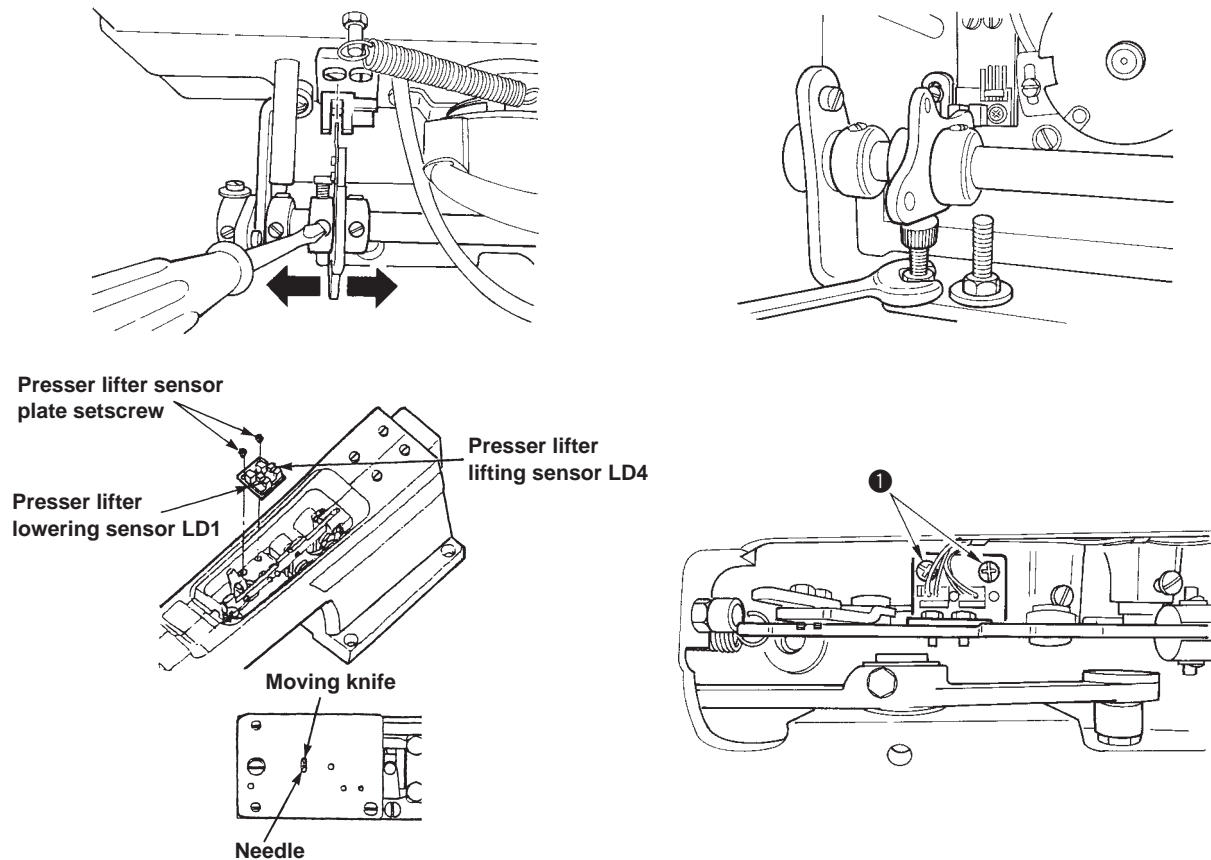

Adjustment Procedures	Results of Improper Adjustment
<p>(1) Adjusting the starting sensor</p> <ol style="list-style-type: none"> 1) Loosen the starting sensor plate setscrews. 2) In the state that the starting lever comes in contact with the starting lever stopper, adjust so that the sensor slit does not pass the sensor and is as high as the sensor, and fix the starting sensor plate setscrews. (20 to 30 kgf) 3) For the crosswise direction, loosen the starting lever bracket setscrews and adjust so that the sensor slit of the starting lever passes the center of the sensor. 4) When the aforementioned adjustment cannot complete the adjustment, loosen the sensor slit setscrews and adjust the position of the sensor slit. 	
<p>(2) Adjusting the presser lifter sensor</p> <ol style="list-style-type: none"> 1) Remove the top cover and the control box cover. 2) Tilt the sewing machine. (When the machine is put in this state, the sewing machine does not rotate if the starting pedal is depressed by mistake when adjusting with the power switch ON.) 3) Turn ON the power switch and press the presser lifter switch, and loosen presser lifter sensor plate setscrews ① with the presser lifted. 4) When the sewing machine is in the starting possible position (position where moving knife does not come in contact with needle), adjust so that LD1 on the MAIN circuit board goes out, then lights up, and fix the sensor with the setscrews. 5) Check that LD4 on the MAIN circuit board goes out, then lights up when the presser is lifted by 2 to 3 mm from the throat plate with the knot-tying adjusting plate. 	

Standard Adjustment

(3) Adjusting the feed origin sensor

Sensor slits are in the same direction.

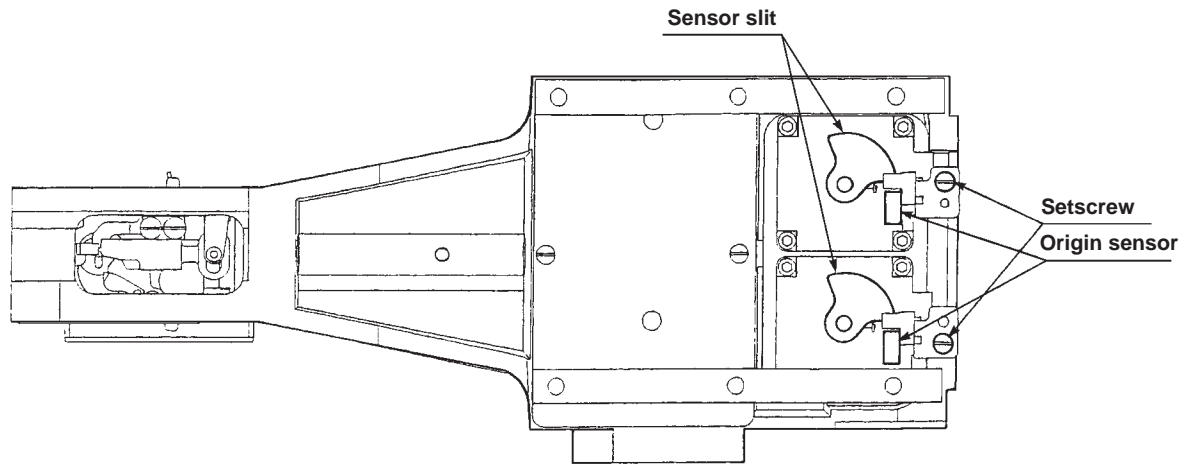

Origin sensor installing plate setscrew

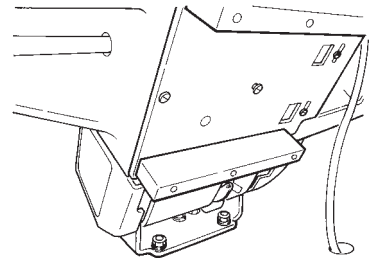
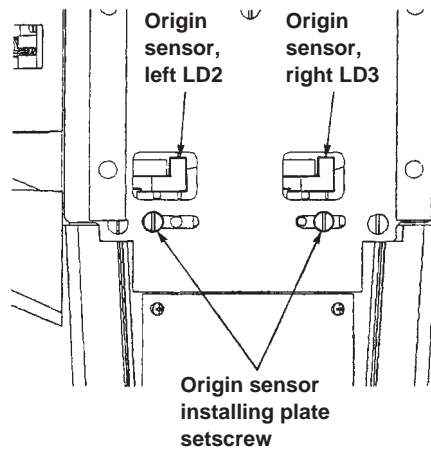
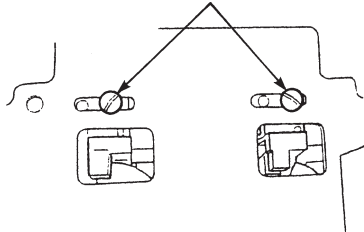

(4) Adjusting the presser lifter stopper

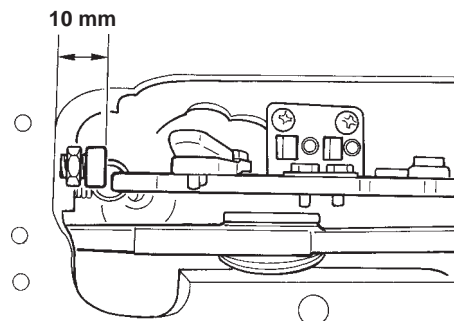

Adjustment Procedures	Results of Improper Adjustment
<p>(3) Adjusting the feed origin sensor</p> <ol style="list-style-type: none"> 1) Remove the hinge screw attached to the machine arm, enter the sensors in the hole of the feed plate, and fix them with the screw hole in the bed. 2) Tilt the sewing machine. 3) Turn ON the power switch. (Remove the control box cover.) 4) Loosen the origin sensor installing plate setscrews. 5) Fix the left-hand sensor as observed from the front of the sewing machine at the position where LD2 on the MAIN circuit board goes out, then lights up. (30 to 40 kgf) 6) Fix the right-hand sensor as observed from the front of the sewing machine at the position where LD3 on the MAIN circuit board goes out, then lights up. (30 to 40 kgf) 	
<p>(4) Adjusting the presser lifter stopper</p> <ol style="list-style-type: none"> 1) Loosen the nut and adjust so that the distance from the end face of the machine arm to the end face of the presser lifter stopper should be 10 mm. 	

8. HOW TO OPERATE AND USE THE MEMORY SWITCH (SERVICE LEVEL)

The operation to adapt the various specifications, more stabilized stitching, etc. can be performed by selecting or changing the various operations, various timings, time, etc. of the sewing machine.

- 1) Pressing **- /Backward** switch and **+ /Forward** switch, turn ON the power, and the display section becomes as shown below. Then the mode will be the display model of the user level. At this time, all of the stitch shape selection LED and the item selection LED flash on and off.



- 2) In this state, keep pressing **- /Backward** switch and **+ /Forward** switch for 5 seconds. Then the display section becomes as shown below, and the mode will be the display mode of the service level. At this time, all of the stitch shape selection LED and the item selection LED flash on and off.



- 3) When the display mode of the service level appeared, press **Set ready switch**. Then the display section becomes as shown below, and the memory switch No. 1 is displayed. The mode becomes the setting mode of the service level.

At this time, all of the stitch shape selection LED flash on and off and only the pattern No. LED of the item selection LED lights up.



- 4) Here, select the memory switch No. desired to be changed by pressing down **- /Backward** and **+ /Forward** switches. In this state, press **Item selection** switch and the display section becomes as shown below (when the memory switch No. 1 is selected). Then set value corresponding to the memory switch No. is displayed.

At this time, all of the stitch shape selection LED flash on and off, and the pattern No. LED of the item selection LED goes out. In addition, when **Item selection** switch is pressed again, the state of step 3) will appear.



- 5) In this state, set the value to the one desired to be changed by pressing down **- /Backward** and **+ /Forward** switches.

When the setting has been completed, turn OFF the power.

(1) Memory switch function table

Memory switch No.	Setting item	Contents of setting	Setting level	Setting range	Setting initial value	Unit
1	Soft start speed setting (1st stitch at the sewing start)	Speed of 1st stitch at the sewing start can be limited.	User	4 to 18	18	x100 [rpm]
2	Soft start speed setting (2nd stitch at the sewing start)	Speed of 2nd stitch at the sewing start can be limited.	User	4 to 18	18	x100 [rpm]
3	Soft start speed setting (3rd stitch at the sewing start)	Speed of 3rd stitch at the sewing start can be limited.	User	4 to 18	18	x100 [rpm]
4	Soft start speed setting (1st stitch at the sewing start after trimming crossover thread)	Speed of 1st stitch at the sewing start after trimming crossover thread can be limited.	User	4 to 18	18	x100 [rpm]
5	Soft start speed setting (2nd stitch at the sewing start after trimming crossover thread)	Speed of 2nd stitch at the sewing start after trimming crossover thread can be limited.	User	4 to 18	18	x100 [rpm]
6	Soft start speed setting (3rd stitch at the sewing start after trimming crossover thread)	Speed of 3rd stitch at the sewing start after trimming crossover thread can be limited.	User	4 to 18	18	x100 [rpm]
7	Knot-tying function selection	Drawing out thread at the sewing end is stopped and thread can be knotted.	User	0/1	1	0 : Ineffective 1 : Effective
8	Wiper function selection	When the without-crossover thread device is mounted, needle thread after thread trimming can be wiped. In case the without-crossover thread device is mounted and the pattern without crossover thread is selected at setting "0" : ineffective, needle thread is automatically wiped only after trimming crossover thread (medium thread trimming).	User	0/1	0	0 : Ineffective 1 : Effective
30	Knot-tying solenoid ON timing angle setting (When memory switch No. 7, knot-tying function is selected)	Knot-tying solenoid ON timing angle (upper dead point of one stitch before the last stitch is regarded as 0°) can be changed.	Service	0 to 40	18	x10 [deg]
31	Knot-tying solenoid OFF timing time setting (When memory switch No. 7, knot-tying function is selected)	Period of time of Knot-tying solenoid OFF timing can be changed.	Service	0 to 10	5	[sec]
32	Wiper solenoid ON timing time setting (When memory switch No. 8, wiper function is selected)	Period of time from thread trimming to wiper solenoid ON timing can be changed.	Service	0 to 20	5	x10 [msec]
33	Wiper solenoid ON hold time setting (When memory switch No. 8, wiper function is selected)	Period of holding time from wiper solenoid ON can be changed. As the number is increased, the operating time of wiper becomes longer.	Service	2 to 20	5	x10 [msec]

Memory switch No.	Setting item	Contents of setting	Setting level	Setting range	Setting initial value	Unit
34	Thread trimming operation setting (1)	Thread trimming (presser lifting) solenoid ON timing angle (upper dead point of one stitch before the last stitch is regarded as 0°) can be changed. As the number is increased, the thread trimming timing is delayed. As the number is decreased, thread trimmer may interfere with needle. So, be careful.	Service	0 to 40	20	x10 [deg]
35	Thread trimming (presser lifting) solenoid ON timing time setting	Do not change.	Service	0 to 20	0	x10 [msec]
36	Presser lifting holding force setting	Holding force when the presser goes up can be changed. As the number is increased, the holding force is strengthened.	Service	0 to 10	6	—
37	Thread trimming operation setting (2) [Crossover thread trimming when without crossover thread pattern is selected (medium thread trimming), or thread trimming when memory switch No. 8, wiper function is selected.]	Thread trimming operation can be adjusted. As the number is increased, operating force of thread trimming is strengthened. However, the presser foot may rise. So, be careful.	Service	30 to 90	45	[msec]
38	Thread trimming operation setting (3) [Crossover thread trimming when without crossover thread pattern is selected (medium thread trimming), or thread trimming when memory switch No. 8, wiper function is selected.]	Do not change.	Service	0 to 10	6	—
39	Thread trimming operation setting (4) [Crossover thread trimming when without crossover thread pattern is selected (medium thread trimming), or thread trimming when memory switch No. 8, wiper function is selected.]	Do not change.	Service	10 to 40	24	x10 [msec]
40	Thread trimming position setting (1)	Thread trimming position can be adjusted. Thread trimming position is determined by the set value of memory switch No. 40, thread trimming position setting (1) or No. 41, thread trimming position setting (2).	Service	-9 to 9	0	Pulse
41	Thread trimming position setting (2)	Thread trimming position can be adjusted. Thread trimming position is determined by the set value of memory switch No. 40, thread trimming position setting (1) or No. 41, thread trimming position setting (2).	Service	-9 to 9	0	Pulse
44	Thread trimming operation setting (1) [For BR]	Thread trimming operation can be adjusted. As the number is increased, operating force of thread trimming is strengthened.	Service	5 to 20	10	x10 [msec]
45	Thread trimming operation setting (2) [For BR]	Do not change.	Service	0 to 10	6	—
46	Feed pulse delivery timing setting	Do not change.	Service	-9 to 9	0	[deg]
47	Thread trimming position function selection	Thread trimming position can be selected.	Service	0/1	1	0 : Hole position 1 : Medium position

9. HOW TO OPERATE AND USE THE INPUT CHECK MODE FUNCTION

Troubles, defects, etc. of the printed circuit boards and elements can be checked by displaying the input state of the various sensors and switches.

- 1) Pressing **Set ready** switch and **Reset** switch, turn ON the power. ("Function No. 1" is displayed.)

Display section  (Flashing display)

- 2) When **Item selection** switch is pressed down, the state of input assigned to "Function No. 1" is displayed.

Display section  [Example of display]
(Light-up display)

(Caution) Input of the origin sensor of feed stepping motor is assigned to "Function No. 1". In this case, left-hand side (10th digit) of the display section, as observed from the front of the sewing machine, is the input state of the origin sensor of left-hand side stepping motor, and right-hand side (1st digit) of the display section, as observed from the front of the sewing machine, is the input state of the origin sensor of right-hand side stepping motor.

- 3) In this state, when the feed mechanism, detecting plate, etc. are moved, the display changes in accordance with the input state of the origin sensor. In this case, when the display is "1", the origin sensor is in the input state of OFF and when the display is "0", the origin sensor is in the input state of ON.
- 4) When performing checking of other function No, press down **Item selection** switch again and the display becomes the display state of step 1). In this state, select the function No. you desire to check by pressing down **- / Backward** and **+ / Forward** switches and perform the operation of step 2).

(1) INPUT CHECK CORRESPONDENCE TABLE

Function No.	Left-hand side of display section (10th digit)	Right-hand side of display section (1st digit)
F1	Origin detection sensor (Left stepping motor) 0 : ON, 1 : OFF [CN20-2]	Origin detection sensor (Right stepping motor) 0 : ON, 1 : OFF [CN21-2]
F2	Presser lifting detection sensor 0 : ON, 1 : OFF [CN30-2]	Presser lowering detection sensor 0 : ON, 1 : OFF [CN30-5]
F3	Pedal start SW 0 : ON, 1 : OFF [CN22-2]	Not used. [CN23-2]
F4	STMG (Input signal for BR) 0 : ON, 1 : OFF [CN24-2]	WMG (Input signal for BR) 0 : ON, 1 : OFF [CN24-4]
F5	Pedal start SW 0 : ON, 1 : OFF [CN28-2]	Pedal presser SW 0 : ON, 1 : OFF [CN28-5]
F6	Not used. [CN27-2]	Not used. [CN27-5]
F7	Operation panel : Reset SW 0 : ON, 1 : OFF [CN25-17]	Operation panel : Stitch shape selection SW 0 : ON, 1 : OFF [CN25-18]
F8	Operation panel : - /Backward SW 0 : ON, 1 : OFF [CN25-19]	Operation panel : + /Forward SW 0 : ON, 1 : OFF [CN25-20]
F9	Operation panel : Set ready SW 0 : ON, 1 : OFF [CN25-22]	Operation panel : Presser SW 0 : ON, 1 : OFF [CN25-23]
FA	Not used. [CN25-24]	Overheat monitoring sensor 0 : ON, 1 : OFF [CN29-1]
Fb	SW1-1 (DIP SW) 0 : ON, 1 : OFF	SW1-2 (DIP SW) 0 : ON, 1 : OFF
Fc	SW1-3 (DIP SW) 0 : ON, 1 : OFF	SW1-4 (DIP SW) 0 : ON, 1 : OFF
Fd	SW1-5 (DIP SW) 0 : ON, 1 : OFF	SW1-6 (DIP SW) 0 : ON, 1 : OFF
FE	SW1-7 (DIP SW) 0 : ON, 1 : OFF	SW1-8 (DIP SW) 0 : ON, 1 : OFF

10. HOW TO OPERATE AND USE THE ALL CLEAR FUNCTION

All of the data (size, number of stitches, etc.) of each pattern No. and the set value of the memory switch can be cleared and returned to the set value at the time of delivery. However, when this operation is performed, all the up-to-date data are deleted. So, be careful

- 1) Pressing **Presser lifting** switch and **Reset** switch, turn ON the power and the display section becomes as shown below.



- 2) In this state, press **Reset** switch and the display section becomes as shown below. Then data deletion operation starts.



- 3) When the data deletion operation has been completed, the display section becomes as shown below, and the flashing is changed to light-up state. At this time, turn ON the power again after turning OFF the power, and the set value is returned to the one at the time of delivery.



11. PARTS TO BE GREASESD

Apply or fill up grease to the following parts.

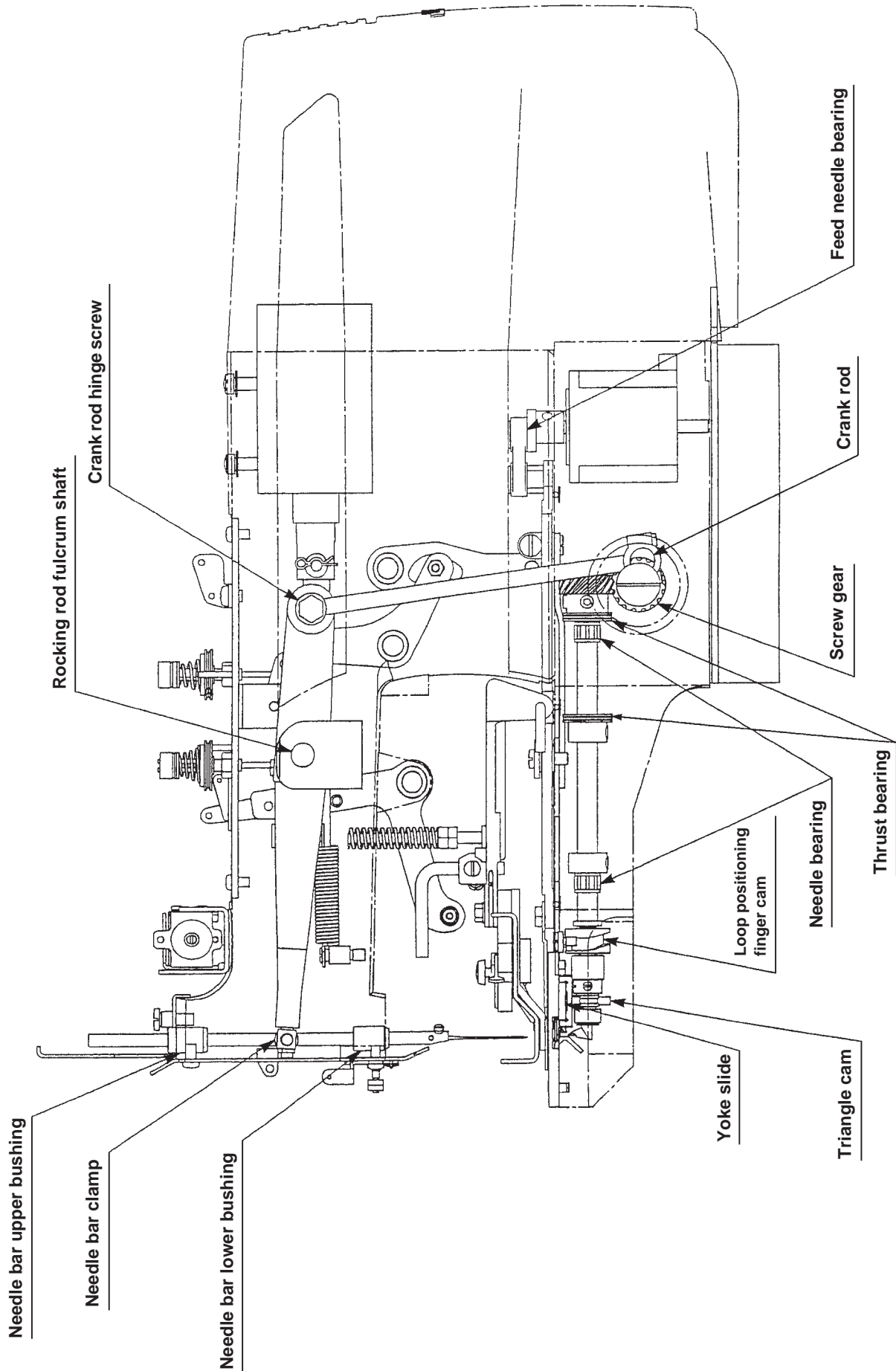

12. ERROR LIST

Error LED located on the left side of the reset switch flashes on and off or lights up when an error occurs. When the LED lights up, the setting state will be made by pressing the reset switch and the error will be released. Error No. will be displayed in the display section A.

Error No.	Item	Description
01	Trouble of sewing data	Pattern has not been inputted in the program of cycle stitching.
02	Trouble of 24V voltage	Trouble of power voltage, trouble of load on main shaft of machine head, trouble of PWR circuit board
03	Dislocation of needle up-position	Trouble of load on main shaft of machine head, trouble of encoder, or loosened encoder fixing screw
04	Dislocation of presser down detection	Foreign materials under presser, dislocation of presser down sensor, or defective down sensor
05	Trouble of presser solenoid	Defective solenoid, dislocation of presser up sensor, or defective up sensor
06	Trouble of servo encoder	Defective encoder or improper fixing of encoder
07	Servo motor lock	Trouble of load on main shaft of machine head, or defective servo motor
09	System trouble	Defective control circuit board or defective program ROM
10	Trouble of stepping motor origin 1	Trouble of origin sensor 1, dislocation of sensor, or trouble of load on stepping motor 1 (left side of operator)
11	Trouble of stepping motor origin 2	Trouble of origin sensor 2, dislocation of sensor, or trouble of load on stepping motor 2 (right side of operator)
12	Overload of servo motor	Trouble of load on main shaft of machine head (short time), or defective servo motor
13	Overload of servo motor	Trouble of load on main shaft of machine head (long time), or defective servo motor
16	Trouble of number of revolution	Defective control circuit board, defective encoder, or defective servo motor
17	Trouble of servo voltage	Defective PWR circuit board
18	Trouble of temperature	Cleaning of fan filter, excessive load on main shaft, or trouble of control circuit board (high temperature of pre-driver)
19	Overcurrent of servo motor	Defective servo motor, or improper timing of encoder
30	Trouble of external ROM	ROM formatting error
31	Trouble of external ROM	Number of stitches (99) is over.
32	Trouble of external ROM	Moving amount of one stitch (lengthwise : 6.5 mm, crosswise : 10 mm) is over.
33	Trouble of external ROM	Outside of sewing possible area
H	Temperature rise	Cleaning of fan filter, defective fan operation, or defective control circuit board (temperature detection)
EE	Trouble of memory	Defective control circuit board (EEPROM)
(Note) Error Nos. 01, 03, 04, 31, 32, and 33 return to the state before the occurrence of the error by pressing the reset switch.		

13. CHANGE-OVER OF THE POWER SOURCE VOLTAGE

This sewing machine has been connected to the power source of 200V to 240V in the state of delivery from the factory.

When using the machine with the power source of 100V to 120V, perform the work of change-over of voltage in the order of the procedures below.

(Caution) 1. Perform the change-over after confirming the voltage of the place where the sewing machine is set and the voltage in the sewing machine.

2. Do not connect the power plug to the receptacle.

- 1) Remove the cover in the rear of the sewing machine and replace from 200V to 100V the connector of connector No. CN32 (blue 2-pin) on the right side PWR circuit board as observed from the front side. See the figure below.
- 2) Install the cover.
- 3) Connect the power plug to the receptacle.
- 4) Completion of the work.

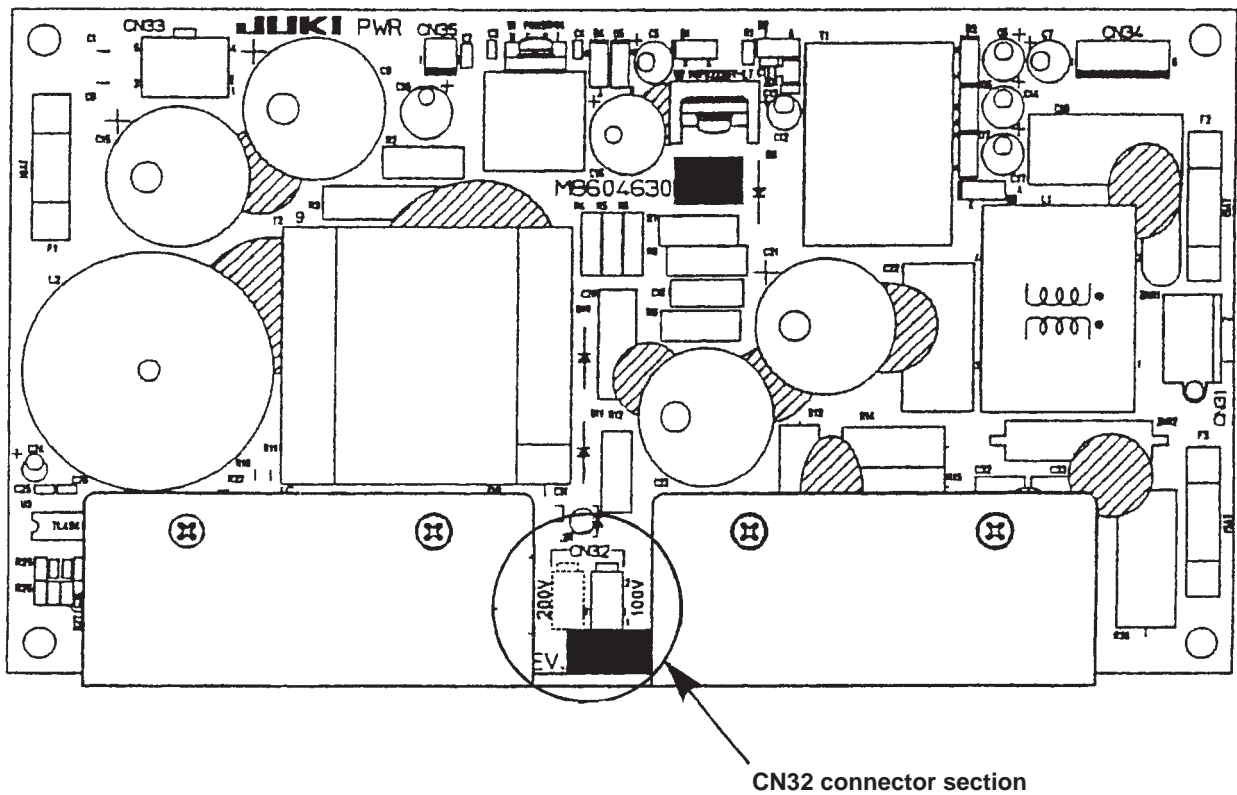

14. CAUSE OF TROUBLES AND THE CORRECTIVE MEASURES

(1) Thread trimming troubles and the corrective measures

Troubles	Causes	Corrective measures
1. Thread is not trimmed.	The thread separating claw of the moving knife fails to separate the thread on a fabric from that on the needle.	Adjust the position of the moving knife. Refer to the item "5. (2) Adjusting the position of the moving knife".
	The needle does not come down into the correct point of a button hole.	Make readjustment by the button clamp holder.
	The final stitch is skipped.	Correct the position on the looper. Refer to the item "4. (2) Positioning the needle and the looper".
	The height of the thread separating claw of the moving knife is not correct.	Correct the height of the thread separating claw of the moving knife. Refer to the item "5. (3) Adjusting the height of the thread separating claw of the moving knife".
2. Both the thread on the needle and that on the wrong side of a fabric are trimmed.	Improper position of the moving knife	Correct the position of the moving knife at the time of completion of the stop motion. Refer to the item "5. (2) Adjusting the position of the moving knife".
	Improper height of the thread separating claw of the moving knife.	Correct the height of the thread separating claw of the moving knife. Refer to the item "5. (3) Adjusting the height of the thread separating claw of the moving knife".
3. The trimmed thread on the wrong side of a fabric is too long.	The trimming timing of the moving knife is bad.	Correct the position of the moving knife. Refer to the item "5. (2) Adjusting the position of the moving knife".
	The lift of the button clamp is too large.	Readjust the lift to 10 mm. Refer to the item "4. (5) Lift and pressure of the button clamp".

(Caution) Adjust the position of the moving knife within a range of 10 to 15 mm.

If the position of the moving knife is readjusted to less than 10 mm, the thread separating claw comes in contact with the counter knife or the yoke slide insert, resulting in damaged thread separating claw of the moving knife.

On the other hand, if it is readjusted to more than 15 mm, the thread separating claw may come in contact with the positioning finger yoke slide while the machine is running, also causing breakage of the thread separating claw.

(2) Cause of troubles and the corrective measures for MB-1800

Troubles	Causes	Corrective measures
1. The machine fails to sew at the start of sewing.	Length of remaining thread is too short.	Adjust the thread adjusting thread guide.
	Speed is fast.	Use the soft-start function.
2. Thread breakage	The thread tension post No. 2 fails to release the thread at correct timing.	Make the thread releasing timing slightly earlier.
	The needle does not enter the center of the holes in the button.	Adjust the position of the button clamp jaw lever holder.
	The needle is too thick for the diameter of the hole in the button.	Replace the needle with a thinner one.
3. Buttons are not sewn tightly.	The thread tension post No. 2 fails to release the thread at correct timing.	Make the thread releasing timing slightly earlier.
	The thread tension post No. 2 does not give sufficient tension.	Increase the tension of the thread tension post No. 2.
	The needle does not enter the center of the holes in the button.	Adjust the position of the button clamp jaw lever holder.
4. Thread cannot be trimmed.	The moving knife does not separate the thread on the fabric with its thread separating claw.	Adjust the position of the moving knife.
	The needle does not enter the center of the holes in the button.	Adjust the position of the button clamp jaw lever holder.
	The last stitch skips.	Adjust the looper.
	The moving knife does not separate the thread on the fabric with its thread separating claw.	Adjust the height of the thread separating claw.
5. Needle thread is cut in two places.	The moving knife does not separate the thread on the fabric with its thread separating claw.	Adjust the position of the moving knife.
	The moving knife separation nail is too high or too low.	Adjust the height of the thread separating claw.

15. CIRCUIT BOARD DIAGRAM

(1) MAIN circuit board

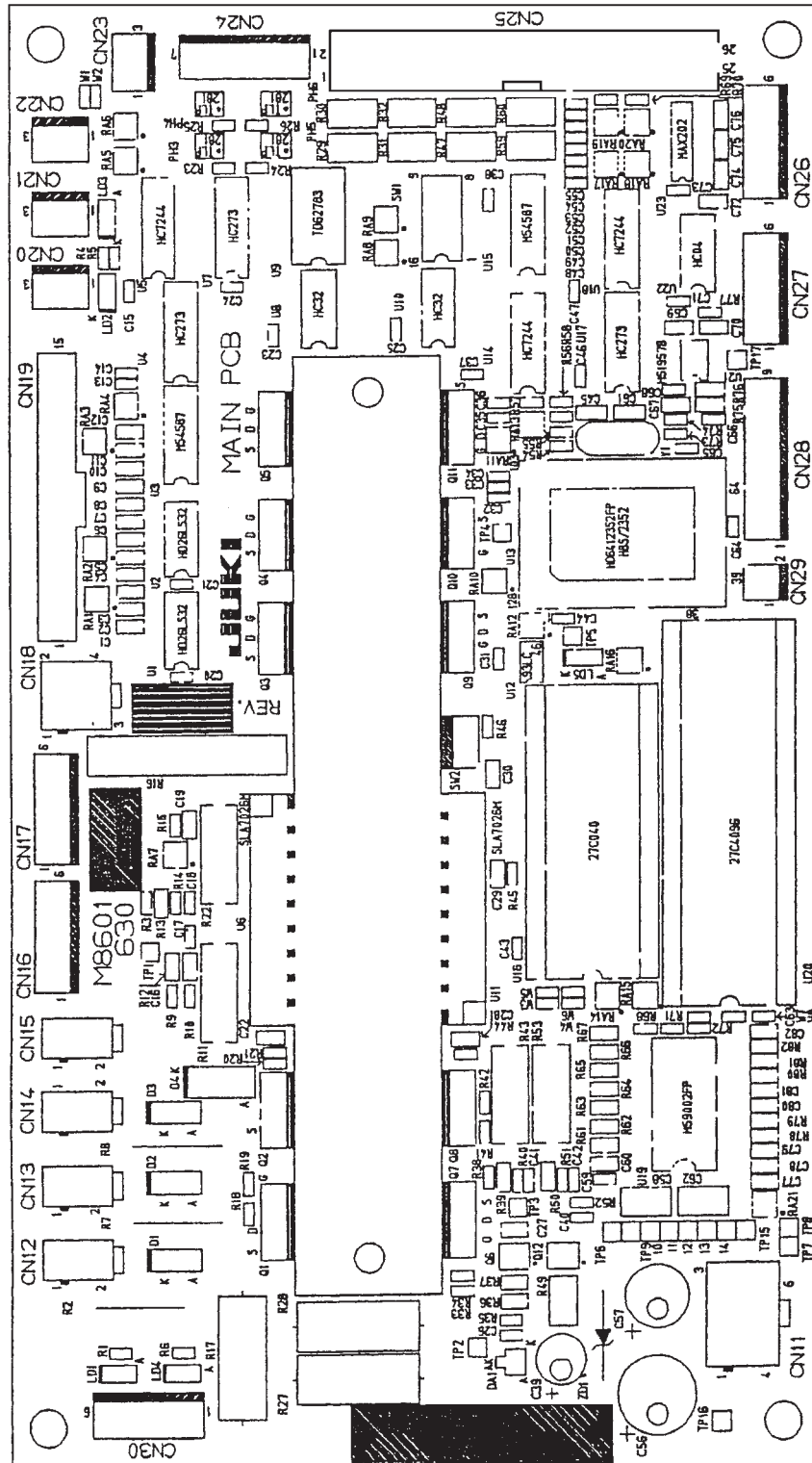

(2) PWR circuit board

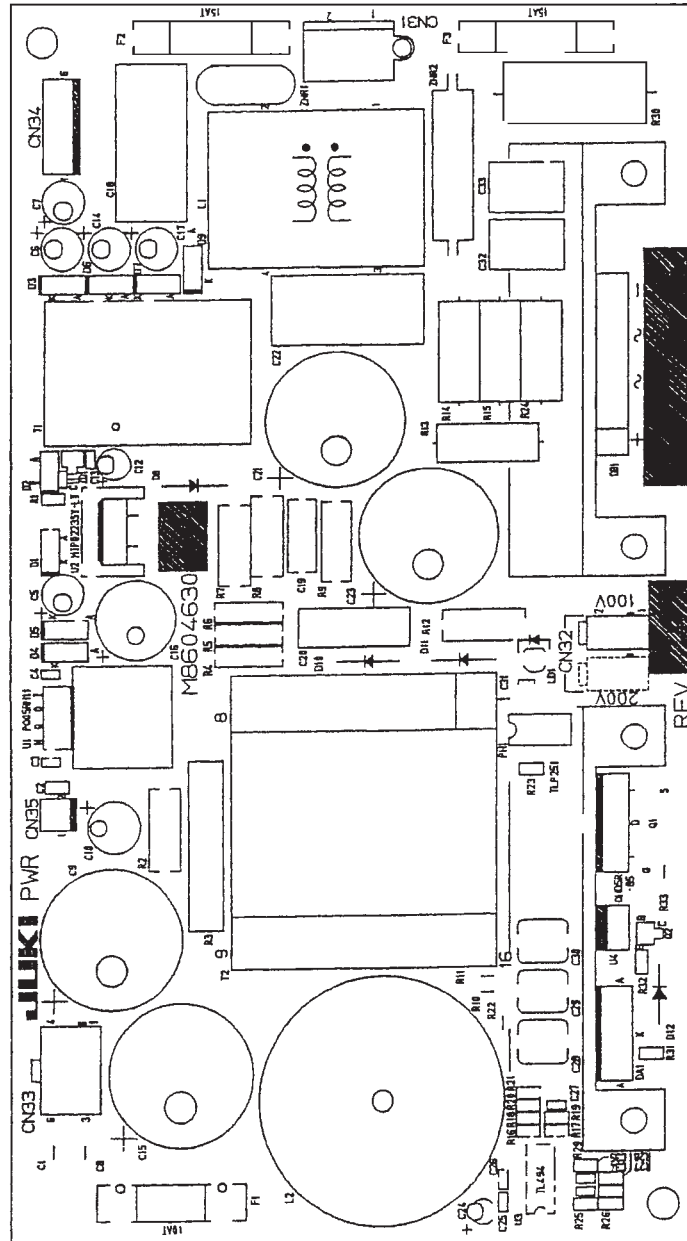

(3) PANEL circuit board

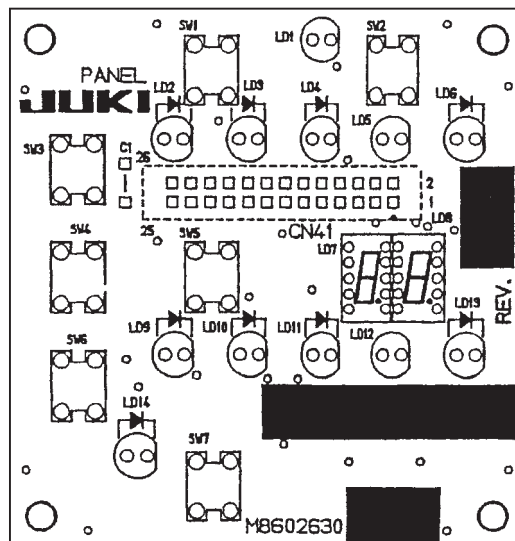

16. BLOCK DIAGRAM 1/2

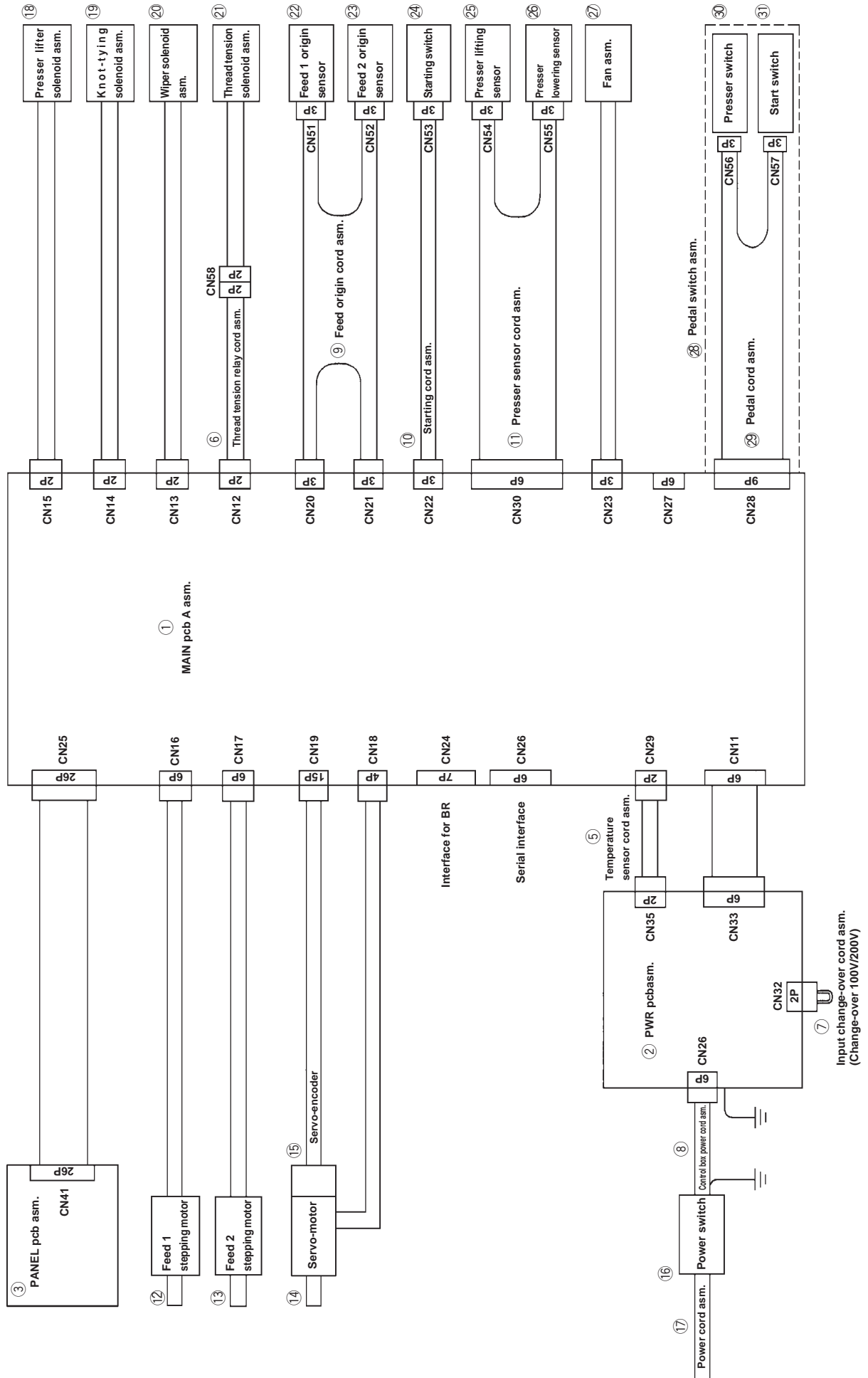

Block diagram 2/2

No.	Part No.	Name of part	Circuit diagram
1	M8601630AA0	MAIN circuit board A asm.	
2	M86046300A0	PWR circuit board asm.	
3	M86026300A0	PANEL circuit board asm.	
4			
5	M85026300A0	Temperature sensor cord asm.	Sensor connection diagram
6	M85196300A0	Thread tension relay cord asm.	Solenoid circuit diagram
7	M85236000A0	Input change-over cord asm.	Power connection diagram
8	M85046300A0	Control box power cord asm.	Power connection diagram
9	M85056300A0	Feed origin cord asm.	Sensor connection diagram
10	M85066300A0	Starting cord asm.	Sensor connection diagram
11	M85076300A0	Presser sensor cord asm.	Sensor connection diagram
12	M8901630000	Feed 1 stepping motor	Motor circuit diagram
13	M8901630000	Feed 2 stepping motor	Motor circuit diagram
14	M8903630000	Servo-motor	Motor circuit diagram
15	M8904630000	Servo-encoder	Encoder circuit diagram
16	HA004250000	Power switch	Power connection diagram
17	M90245800A0	Power cord asm.	Power connection diagram
18	M85086300A0	Presser lifter solenoid asm.	Solenoid circuit diagram
19	M85096300B0	Knot-tying solenoid asm.	Solenoid circuit diagram
20	M85176300A0	Wiper solenoid asm.	Solenoid circuit diagram
21	M85186300A0	Thread tension solenoid asm.	Solenoid circuit diagram
22	HD00057000A	Feed 1 origin sensor	Sensor connection diagram
23	HD00057000A	Feed 2 origin sensor	Sensor connection diagram
24	HD00057000A	Starting switch	Sensor connection diagram
25	HD000570000	Presser lifting sensor	Sensor connection diagram
26	HD000570000	Presser lowering sensor	Sensor connection diagram
27	M85405900A0	Fan asm.	Power connection diagram
28	M85205900A0	Pedal switch asm.	Sensor connection diagram
29	M90115900A0A	Pedal cord asm.	Sensor connection diagram
30	HD001930000	Presser switch	Sensor connection diagram
31	HD001930000	Start switch	Sensor connection diagram
32			
33			
34			
35			
36			
37			
38			
39			
40			

17. CONNECTION DIAGRAM AND CIRCUIT DIAGRAM

(1) Power connection diagram

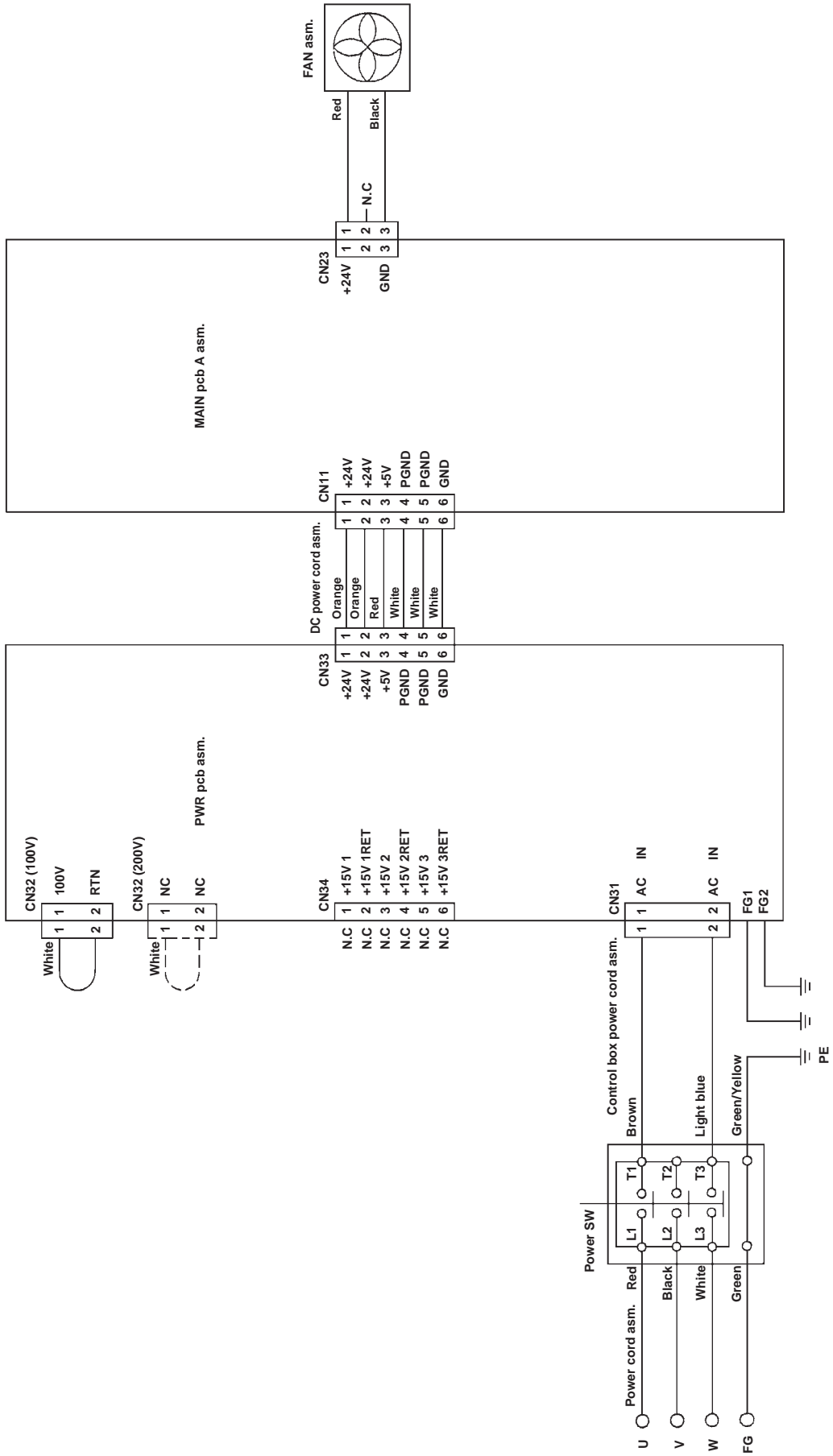

(2) Sensor connection diagram

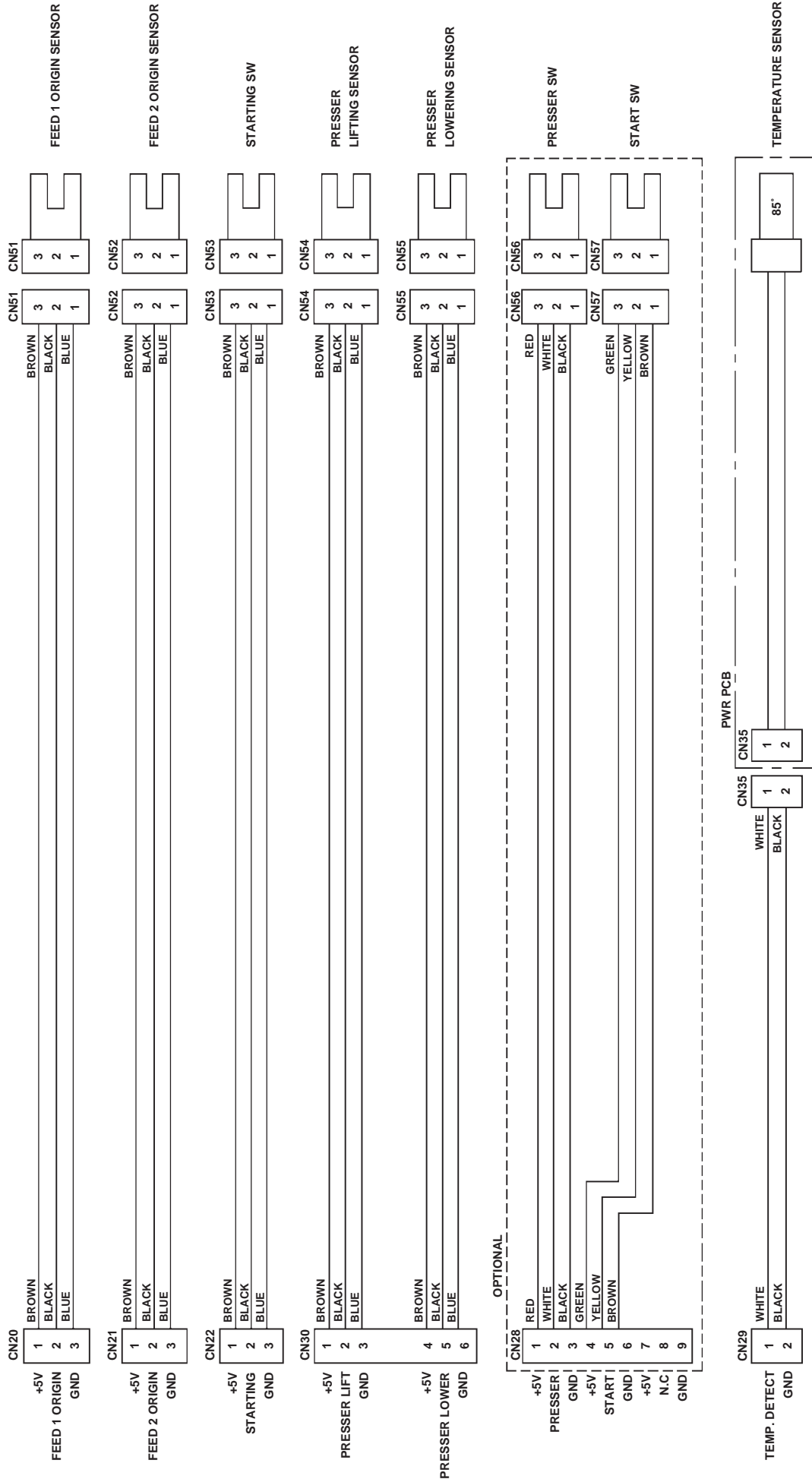

(4) Encoder circuit diagram

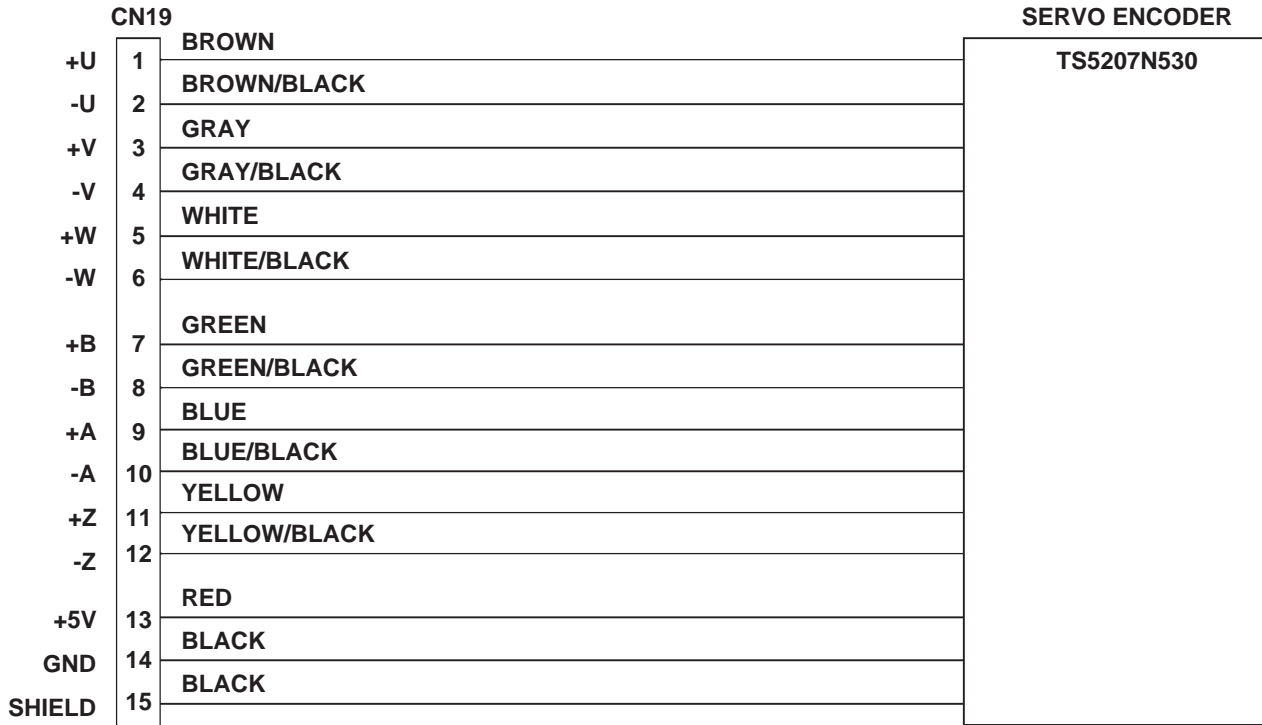

(5) Solenoid circuit diagram

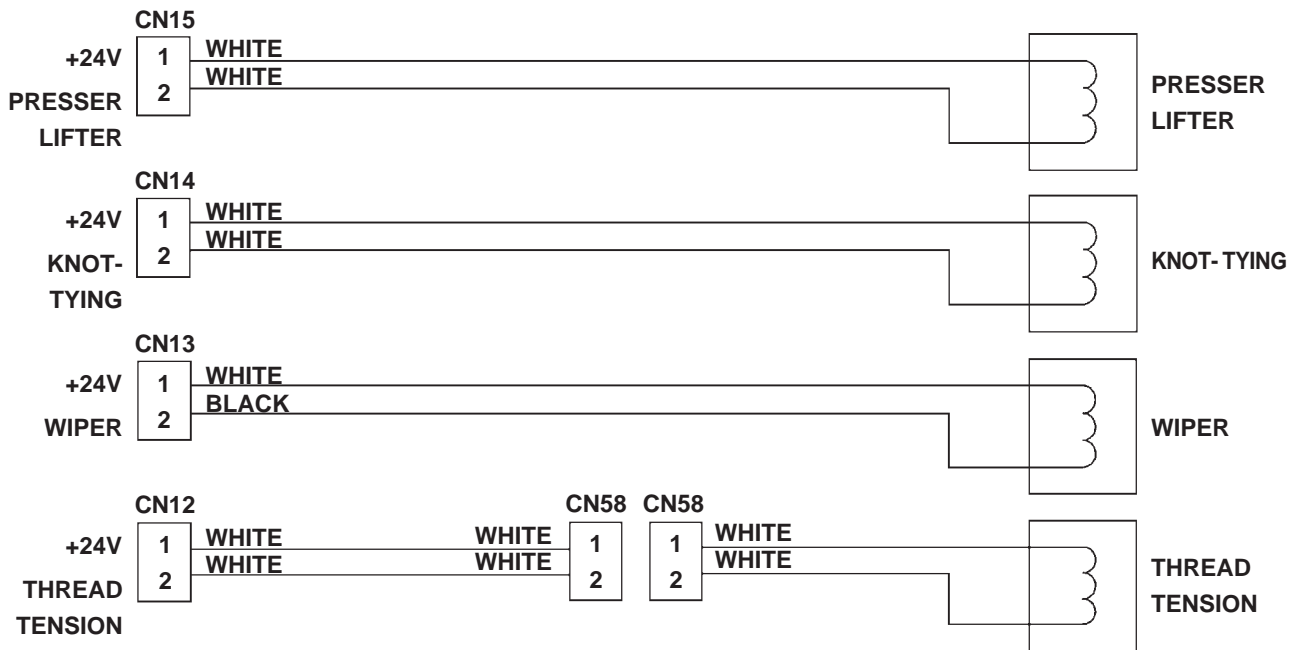

18. DRAWING OF THE TABLE

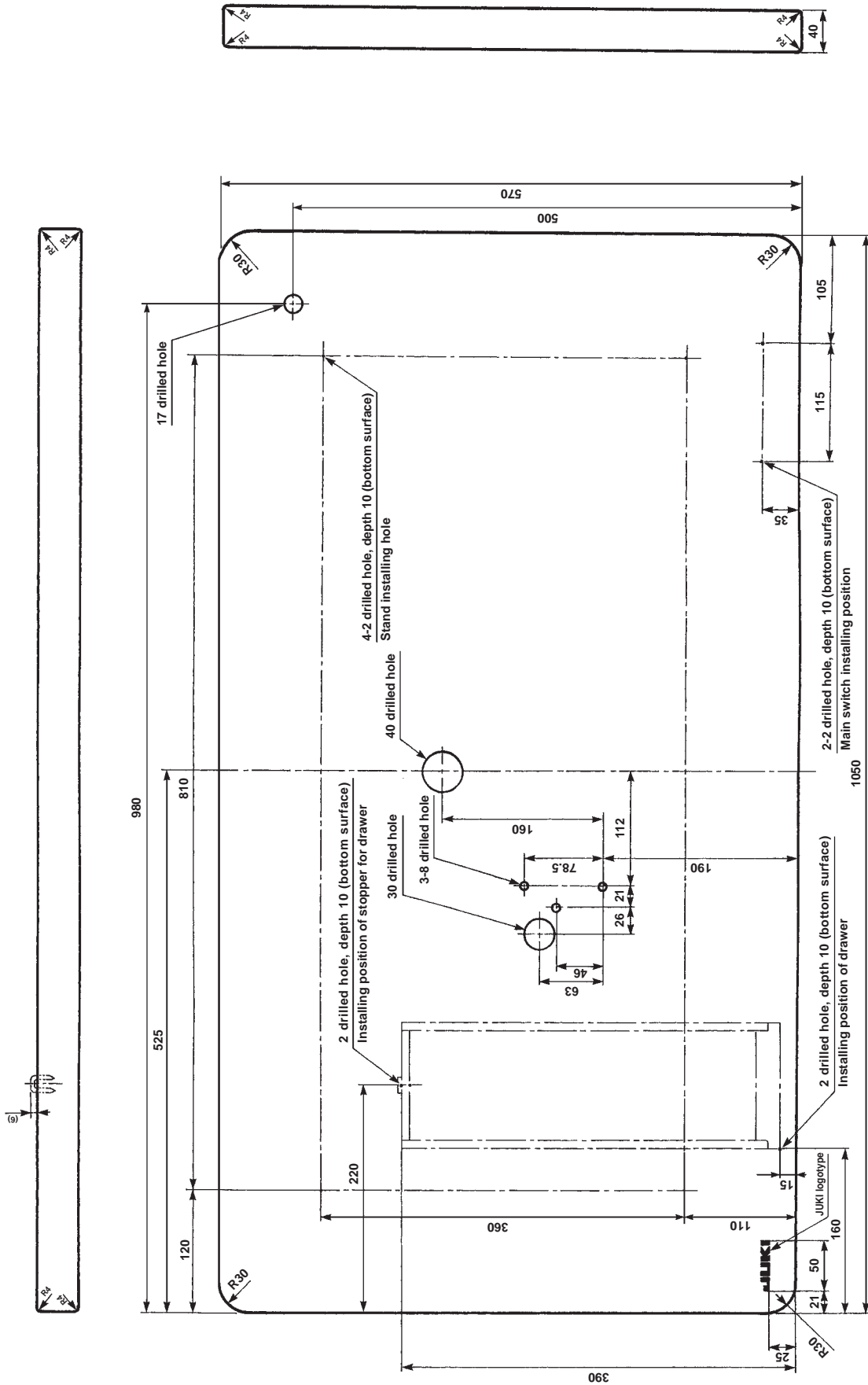

3. Painting inside of cut portion is not necessary.

2. Do not peel the protection sheet from the surface of table.

(Note) 1. Tolerance of hole without indication is ± 0.7 and that of others ± 1.0 .

JUKI®

JUKI CORPORATION

INTERNATIONAL SALES DIVISION
8-2-1. KOKURYO-CHO.
CHOFU-SHI. TOKYO 182-8655. JAPAN
PHONE : (81)3-3430-4001 to 4005
FAX : (81)3-3430-4909 • 4914 • 4984
TELEX : J22967

Copyright © 2000 JUKI CORPORATION.
All rights reserved throughout the world.



Please do not hesitate to contact our distributors or agents in your area for further information when necessary.
*** The description covered in this engineer's manual is subject to change for improvement of the commodity without notice.**