

JUKI®

LZ-2280Nシリーズ

LZ-2280N Series

Serie LZ-2280N

Serie LZ-2280N

Serie LZ-2280N

Serie LZ-2280N

LZ-2280N系列

ENGINEER'S MANUAL

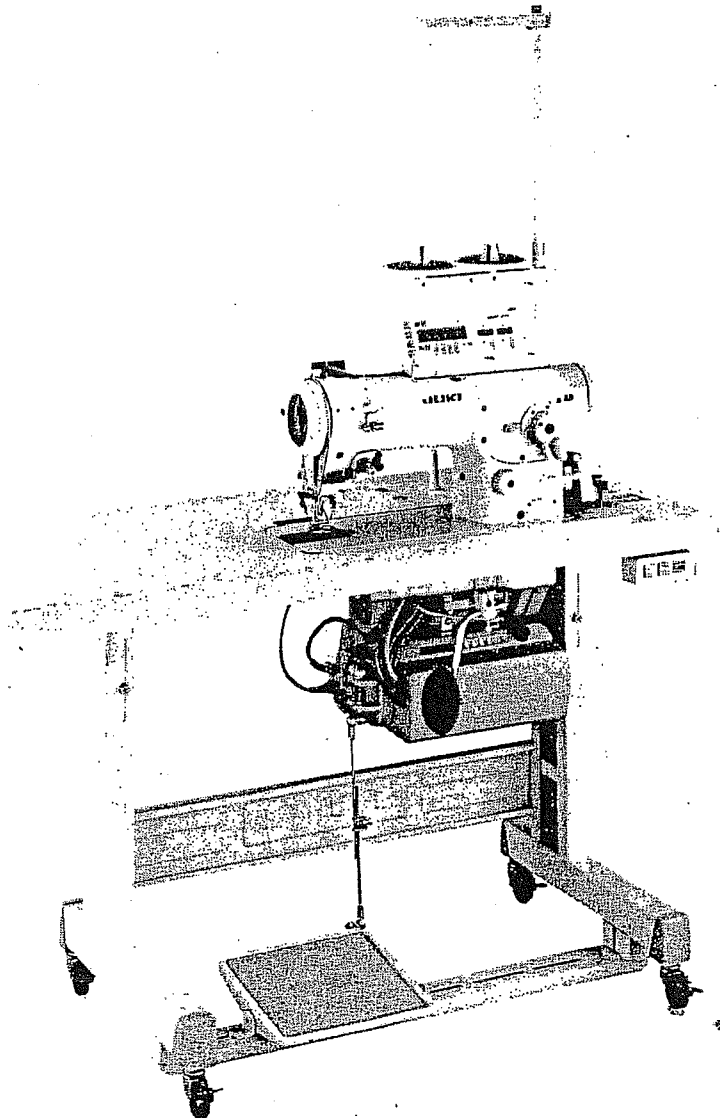

PREFACE

This Engineer's Manual is written for the technical personnel who are responsible for the service and maintenance of the machines.

The Instruction Manual for these machines intended for the maintenance personnel and operators at an apparel factory contains detailed operating instructions. And this manual describes "How to Adjust", "Effects of Adjustment", and other information which are not covered by the Instruction Manual.

It is advisable to use the pertinent Instruction Manual and Parts List together with this Engineer's Manual when carrying out the maintenance of these machines.

This manual mainly consist of three sections; the first section presents "Standard Adjustment", the second section, "How to Adjust", and the thrid, "Results of Improper Adjustment".

CAUTION

1. Keep your hands away from the needle when you turn the power switch ON or while the machine is operating.

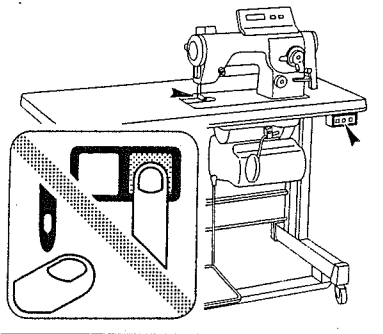

2. Do not put your fingers into the thread take-up cover while the machine is operating. Do not operate your machine with thread take up cover removed.

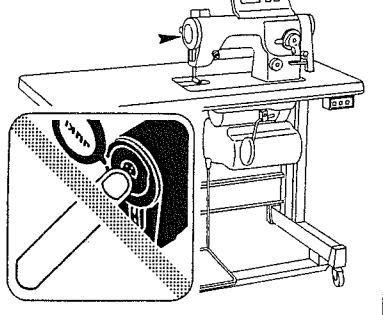

3. Be sure to turn the power switch OFF before tilting the machine head or removing the V belt.

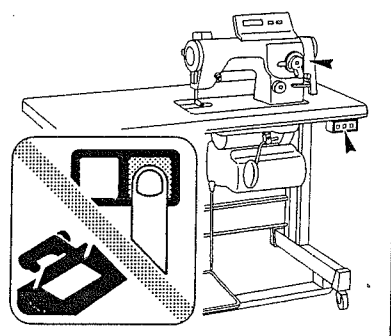

4. When an operator leaves from the machine, make sure to turn off the power.

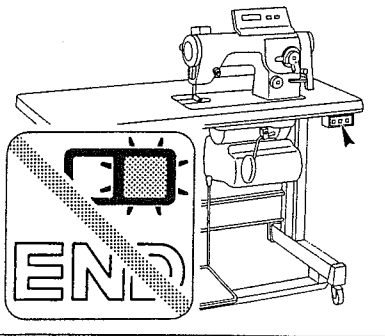

5. During operation, be careful not to allow your or any other person's head or hands to come close to the handwheel, V belt, bobbin winder or motor. Also, do not place anything close to them. Doing so may be dangerous.

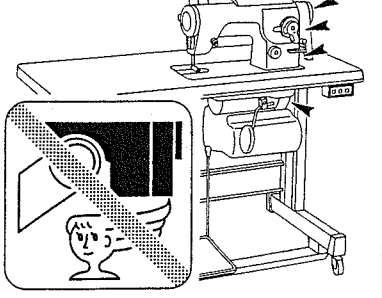

6. If your machine is provided with a belt cover, finger guard or any other protectors, do not operate your machine with any of them removed.

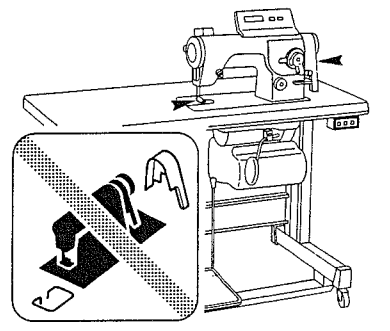

BEFORE OPERATION

1. Never operate the machine unless its oil pan has been filled with oil.
2. After setting up the machine, check the direction of motor rotation. To check it, turn the handwheel by hand to bring the needle down, and turn the power switch ON while observing the handwheel. (The handwheel should turn counterclockwise as observed from the handwheel side.)
3. Do not enlarge the motor pulley for the first month.
4. Confirm that the voltage and phase (single- or 3-phase) are correct by checking them against the ratings shown on the motor nameplate.

CONTENTS

1. SPECIFICATIONS	1
2. STANDARD ADJUSTMENT	
(1) Adjusting the feed timing	2
(2) Height and inclination of the feed dog	2
(3) Position of the feed dog	4
(4) Adjusting the feed amount	4
(5) Timing of the needle rocking cam	6
(6) Adjusting the position of needle entry (in terms of the needle rocking direction)	6
(7) Adjusting the needle entry position (in terms of longitudinal direction)	8
(8) Position of the needle bar connection guide	8
(9) Adjusting the zigzag width	10
(10) Adjusting the zigzag width adjusting lever	10
(11) Adjusting the position of the needle position changing lever	12
(12) Timing gauge	14
(13) Needle bar height	14
(14) Adjusting the needle-to-hook timing and the needle guard	16
(15) Position of the bobbin case stopper	18
(16) Orientation of the needle bar thread holder	18
(17) Auxiliary thread take-up lever	20
(18) Position of the thread tension controller	22
(19) Position of the pre-tension disk	22
(20) Adjusting the stroke of the thread take-up spring and the tension of the spring	24
(21) Position of the thread take-up spring guard	24
(22) Installing the take-up thread guide B	24
(23) Height and inclination of the feed dog	24
(24) Installation of the needle	26
(25) Installation of the presser foot	26
(26) Adjusting the presser foot pressure	26
(27) Adjusting the micro-lifting mechanism	26
(28) Adjusting the amount of oil in the face plate	28
(29) Adjusting the amount of oil in the hook	28
LZ-2280-7, LZ-2286-7	
(30) Position of the counter knife	30
(31) Initial position of the moving knife	32
(32) Timing of the thread trimming cam	32
(33) Installing/removing the knife unit	34
(34) Stop position of the needle after thread trimming	34
(35) Clearance provided between the main shaft handwheel and the stator	34
(36) Position of the one-touch type reverse stitching switch lever	36
(37) Position of the automatic reverse stitching magnet	36
(38) Installing the thread tension releasing solenoid and adjusting it	36
(39) Adjusting the installed state of the stopper plate	38
(40) Position of the needle thread feeding device	38
(41) Adjusting the position of the thread feeding wire	40
(42) Adjusting the stroke of the thread feeding wire	40
(43) Installing the wiper base	42
(44) Adjusting the wiper solenoid	42
(45) Position of the wiper	44
LZ-2286	
(46) Installing the presser foot and adjusting it	46
(47) Adjusting the slippage of the right- and left-hand side materials	46
(48) Feed timing for the LZ-2285	48
3. MOTOR PULLEY AND BELT	50
4. ADDITIONAL MACHINING TO THE COMMERCIALY-AVAILABLE FEED MECHANISM	51
5. HOW TO WIND A BOBBIN	51
6. SCREWS FOR ATTACHMENTS	51
7. TROUBLES AND CORRECTIVE MEASURES (WITH REGARD TO SEWING)	52

2. STANDARD ADJUSTMENT

STANDARD ADJUSTMENT

(1) Adjusting the feed timing

- The feed dog should descend when the marker line engraved on the thread take-up is aligned with marker line C engraved on the face plate.
Condition: Feed dog height 0.8 mm

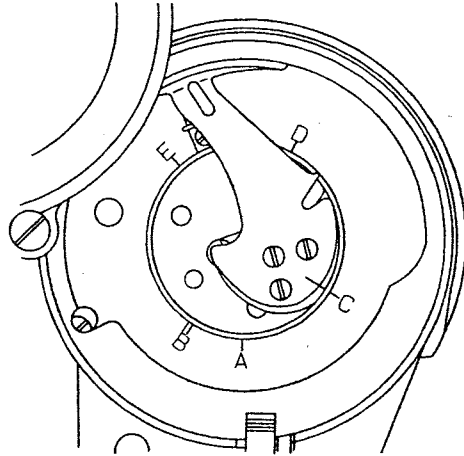

(2) Height and inclination of the feed dog

Height: 0.8 mm

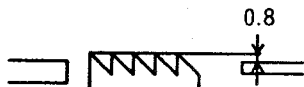

Inclination: The feed dog should be leveled when the top surface of the ascending feed dog is flush with the top surface of the throat plate.

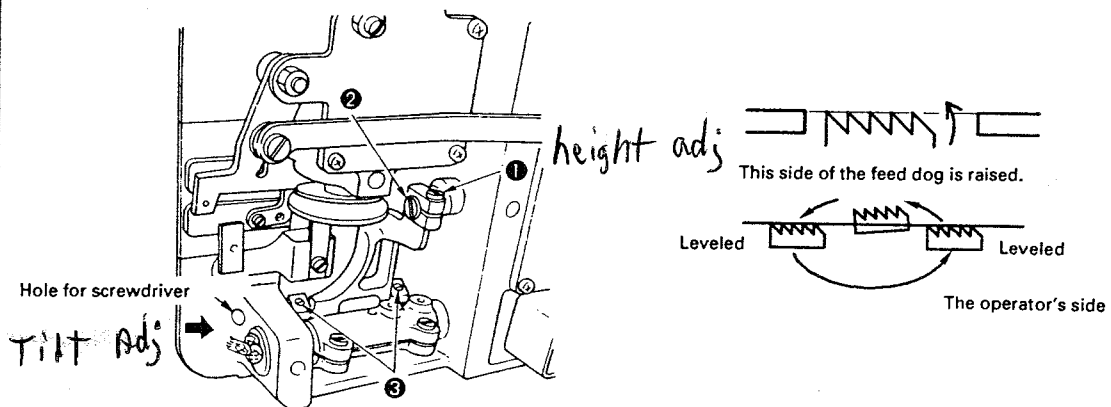

HOW TO ADJUST	RESULT OF IMPROPER ADJUSTMENT
<p>1. Maximize the feed amount. (2.5 mm (LZ-2280) (2 mm (LZ-2286/-2287)), or 2.2 mm (LZ-2285))</p> <p>2. Align the marker line engraved on the thread take-up with marker line C engraved on the face plate.</p> <p>3. In the aforementioned state, loosen the screw in the hook driving shaft sprocket. Now, turn the hook driving shaft to adjust so that the feed dog comes down.</p> <p>(Caution) After the aforementioned adjustment, "timing of the needle rocking cam" and "hook timing" will change. For the machine equipped with a thread trimmer, "timing of the thread trimming cam" as well as the timing of the above-stated components will change. So, be sure to re-adjust them properly.</p>	
<p>1. Adjusting the height of the feed dog Loosen screw ①, and adjust the height of the feed dog by turning feed driving link ②.</p> <p>2. Adjusting the inclination of the feed dog Loosen screws ③. Put a screwdriver through the hole for screw driver and adjust the inclination of the feed dog by turning feed rocker shaft with the screwdriver.</p> <p>(Caution) If the feed rocker shaft is not pressed in the direction of the arrow (⇒) during the adjusting procedure, there will be a play at the feed bar or washer will come off. So, be sure to adjust the feed dog with the feed rocker shaft pressed in the direction of the arrow (⇒).</p> <p>3. The standard height of the feed dog is 0.8 mm. (It is 0.9 mm for the LZ-2285.) Adjust the height of the feed dog to 0.6 mm when sewing a light-weight material, or to 1.0 mm when sewing a heavy-weight material.</p>	

STANDARD ADJUSTMENT

(3) Position of the feed dog

Condition: Feed amount 0

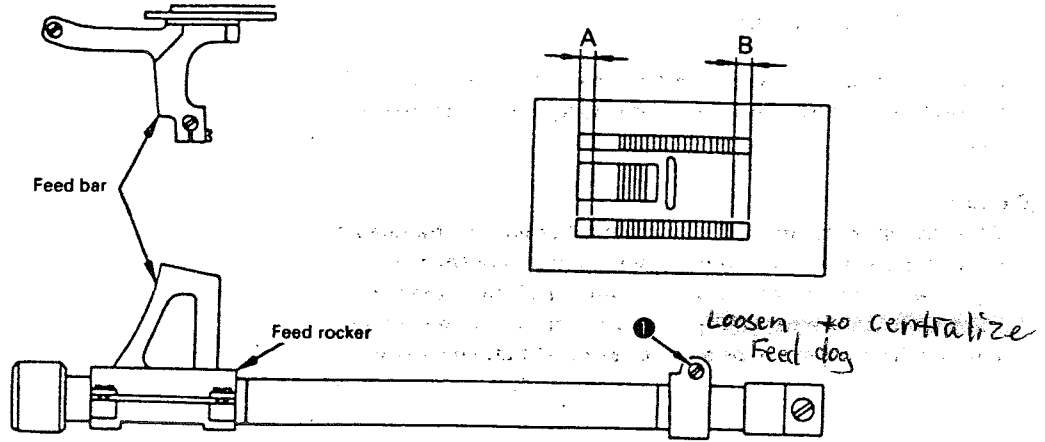

(4) Adjusting the feed amount

Condition: Feed amount 0

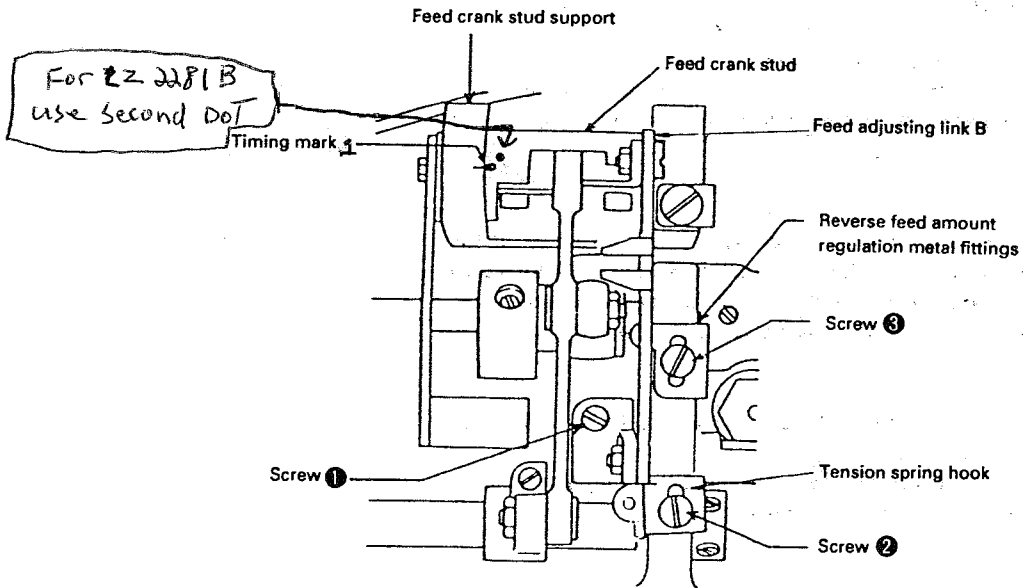

HOW TO ADJUST	RESULT OF IMPROPER ADJUSTMENT							
<p>1. Set the stitch length dial at "0."</p> <p>2. Loosen screw ❶, and adjust so that the feed dog is positioned at the center of the slot in the throat plate. (A=B)</p> <p>(Caution) After the completion of adjustment, set the stitch length dial at the maximum value on the scale and confirm that the feed dog does not come in contact with the throat plate by turning the pulley.</p>	<p>○ The feed dog will come in contact with the throat plate.</p>							
<p>1. Set the stitch length dial at "0."</p> <p>2. Loosen screw ❶, and align the timing mark on the feed crank stud with that on the feed crank stud support.</p> <p>3. When tightening screw ❶, confirm that there is no axial play at the feed converting arm C.</p> <p>4. Set the stitch length dial at the maximum value.</p> <table border="1" data-bbox="327 1119 834 1234"> <tr> <td rowspan="3">Max. feed amount</td> <td>LZ-2280</td> <td>2.5 mm</td> </tr> <tr> <td>LZ-2286</td> <td>2 mm</td> </tr> <tr> <td>LZ-2287</td> <td>2 mm</td> </tr> </table> <p>5. Loosen screw ❷ . Pressing the feed converting link B against the tension spring hook, tighten screw ❷ .</p> <p>6. Loosen screw ❸ , pushing the feed lever down to make the sewing machine enter the reverse stitching mode, press reverse feed amount regulation metal fittings against the projecting section of the feed converting link B. Now, tighten screw ❸ . (Set the condensation stitch length adjusting dial to the maximum value on the scale.)</p> <p>7. To decrease the reverse feed stitch length for fastening stitching, use the condensation stitching function. (Refer to "Adjusting the condensation stitching mechanism" in the Instruction Manual for the LZ-2280 Series.)</p>	Max. feed amount	LZ-2280	2.5 mm	LZ-2286	2 mm	LZ-2287	2 mm	<p>○ If the timing marks are not aligned with each other, the actual feed amount will be different from the feed amount specified on the stitch length dial. If the timing marks greatly separate from each other, the normal or reverse feed amount will be increased causing the feed dog to come in contact with the throat plate.</p>
Max. feed amount		LZ-2280	2.5 mm					
		LZ-2286	2 mm					
	LZ-2287	2 mm						

STANDARD ADJUSTMENT

(5) Timing of the needle rocking cam

Condition: Zigzag width 0

Fig. 1

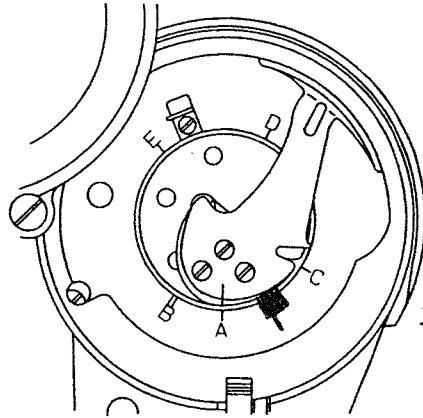

Set between A and C
For 2288 only

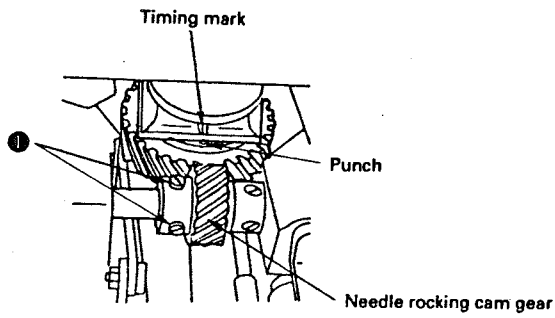

Fig. 2 LZ-2280

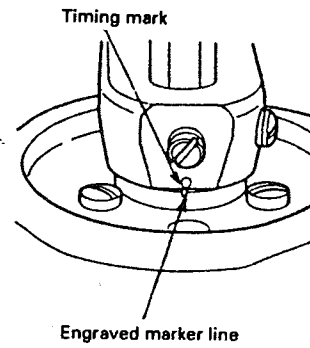
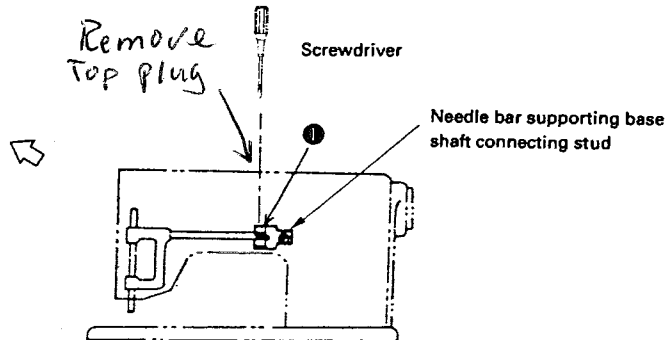
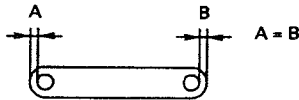
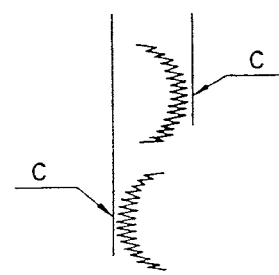

Fig. 3 LZ-2285, -2286, -2287

(6) Adjusting the position of needle entry (in terms of the needle rocking direction)

Condition: Needle position changing lever is set at the center of its moving range.
: Zigzag width is maximized.



HOW TO ADJUST	RESULT OF IMPROPER ADJUSTMENT
<ol style="list-style-type: none"> 1. Align the marker line engraved on the thread take-up with marker line A (showing the lowest dead point of the needle bar) engraved on the face plate. (Fig. 1) 2. Set the zigzag width at "0" on the scale. 3. (1) For the LZ-2280, loosen two screws ❶ in the needle rocking cam gear and align the punch on the needle rocking cam with the timing mark on the needle rocking rod. Now, tighten the screws. (Fig. 2) (2) For the LZ-2285, -2286 and -2287, loosen four screws in the worm and align the marker line engraved on the needle rocking cam with the timing mark on the needle rocking rod guide. Now, tighten the four screws. (Fig. 3) 	<ul style="list-style-type: none"> ○ If the timing of the needle rocking cam is not properly adjusted, needle fray, fabric yarn breakage and stitch skipping may result.
<ol style="list-style-type: none"> 1. Set the needle position changing lever at the center of its moving range. 2. Remove the rubber cap from the top of the machine arm. Maximize the zigzag width and adjust so that clearance A is equal to clearance B using screw ❶. <p>(Caution)</p> <ol style="list-style-type: none"> 1. Do not tap the needle bar or push it hard when adjusting the needle entry. 2. For the LZ-2287, perform the adjustment by inverting the pattern at point C shown in the figure on the right. 	<ul style="list-style-type: none"> ○ Thread will not be uniformly tensed when the needle throws to the right and left, or thread breakage or needle breakage will result. 

STANDARD ADJUSTMENT

(7) Adjusting the needle entry position (in terms of longitudinal direction)

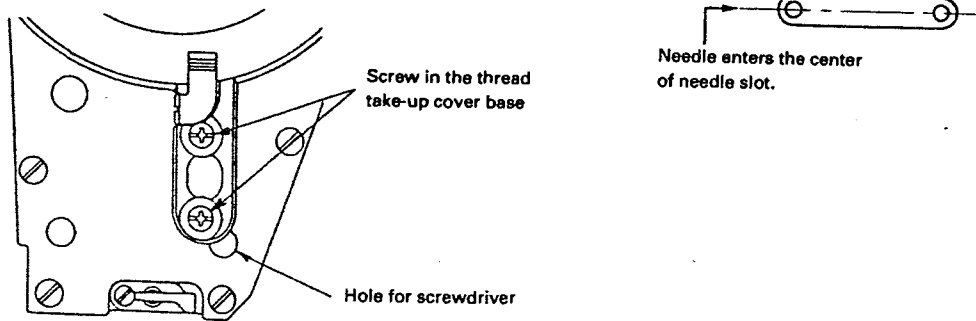

(8) Position of the needle bar connection guide

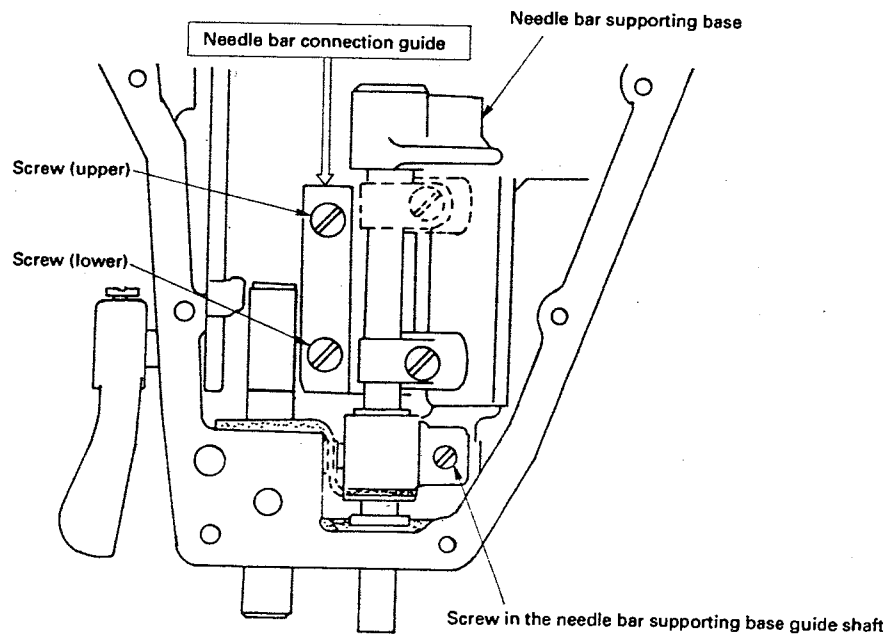

HOW TO ADJUST	RESULT OF IMPROPER ADJUSTMENT
<ol style="list-style-type: none"> 1. Loosen the screw in the thread take-up cover base and remove the thread take-up cover. 2. Loosen the screw, which can be observed through the hole for screw-driver, in the needle bar supporting base guide shaft. 3. Move the needle bar back or forth to adjust so that the needle enters the center of the needle slot in the throat plate. 4. Fix the needle bar supporting base guide shaft. 5. Check the pulley for an extra load by turning the pulley. <p>(Caution) The needle entry position in terms of the longitudinal direction should be finely adjusted. If the needle bar has to be moved by a large margin for the adjustment of the needle entry position in case of replacement of gauges, carry out the adjustment referring to "(8) Position of the needle bar connection guide."</p>	<ul style="list-style-type: none"> o If the needle entry position is not correct, thread breakage, stitch skipping and needle breakage will result.
<ol style="list-style-type: none"> 1. Loosen the screw in the needle bar supporting base shaft connecting stud referring to "(6) Adjusting the position of needle entry (in terms of the needle rocking direction)." 2. Remove the thread take-up cover, thread take-up and face plate. Then, loosen the screws (upper) and (lower) in the needle bar connection guide. 3. Loosen the screw in the needle bar supporting base guide shaft and adjust the needle entry point in terms of the needle rocking direction. Then, tighten the screw. 4. Bring the needle bar to the lowest point of its stroke. Move the needle bar supporting base in the needle rocking direction until a position at which the base smoothly slide is found. Now, temporarily tighten the screw (lower) in the needle bar connection guide. 5. Bring the needle bar to the highest point of its stroke. Move the needle bar supporting base in the needle rocking direction until a position at which the base smoothly slide is found. Now, tighten the screw (upper) in the needle bar connection guide. 6. Securely tighten the screw (lower) in the needle bar connection guide. 7. Check the pulley for an extra load by turning the pulley. 8. Perform the adjusting procedure described in "(6) Adjusting the position of needle entry (in terms of the needle rocking direction)." 9. Attach the face plate, thread take-up and thread take-up cover in position. 	<ul style="list-style-type: none"> o If the needle bar connection guide is not properly positioned, the needle bar and needle bar connection guide will wear out.

STANDARD ADJUSTMENT

(9) Adjusting the zigzag width

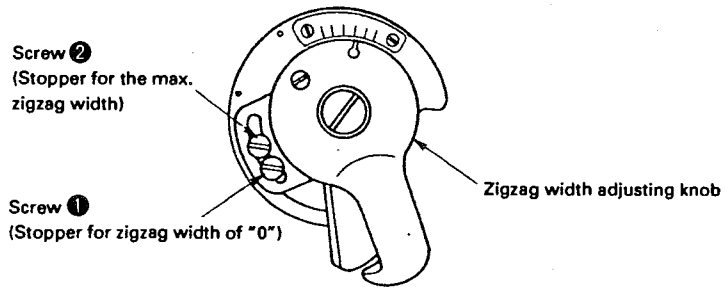

(Caution)

If screws ① and ② are excessively tightened, the zigzag width adjusting knob will crack. So, carefully tighten them.

(10) Adjusting the zigzag width adjusting lever

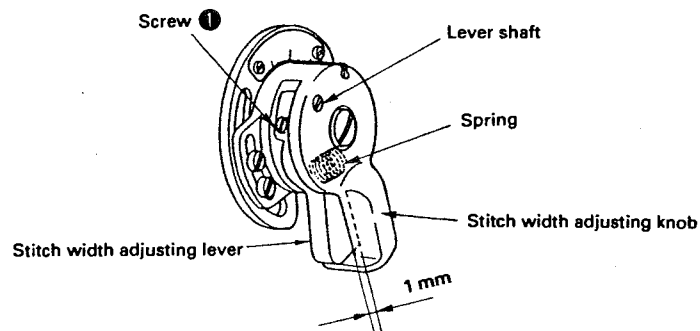

- For reference, zigzag width adjusting lever should overlap the stitch width adjusting knob by approximately 1 mm when zigzag width adjusting lever is moved away from the finger.
- The stitch width adjusting knob should not turn or loosen when the stitch width adjusting lever is not pressed.

HOW TO ADJUST	RESULT OF IMPROPER ADJUSTMENT
<ol style="list-style-type: none"> 1. Determine the "0" of zigzag width by adjusting the position of the stopper of screw ❶ . 2. Adjust the max. value of zigzag width by adjusting the position of the stopper of screw ❷ . <p>(Caution) Take care not to allow the zigzag width to exceed the specified max. one of each model of sewing machine. For the LZ-2286 model of sewing machine, the max. zigzag width has been factory-adjusted to 8 mm at the time of delivery. If the machine is used with the zigzag width set to 8 to 10 mm, the presser foot, throat plate and feed dog should be replaced with those described below in addition to the performance of the aforementioned adjustment.</p> <p style="text-align: center;"> Part No. Presser foot: 100 45052 Throat plate: 100 41002 Feed dog: 100 47009 </p>	<ul style="list-style-type: none"> ○ If the zigzag width is excessive, stitch skipping, thread breakage and needle breakage will result.
<ol style="list-style-type: none"> 1. Loosen screw ❶ while lightly holding the stitch width adjusting lever so as to prevent the spring from falling out of position. 2. Push the stitch width adjusting lever. 3. Now, turn the lever shaft in direction Ⓐ to provide the shaft with an appropriate play. Then tighten screw ❶ . 	<ul style="list-style-type: none"> ○ If the stitch width adjusting lever is not properly adjusted, the knob will not be turned or the zigzag width will change during sewing.

STANDARD ADJUSTMENT

(11) Adjusting the position of the needle position changing lever

- The needle position changing lever works in such a way that the needle entry moves to the right when the lever is moved upward from the center or to the left when it is moved downward from the center.

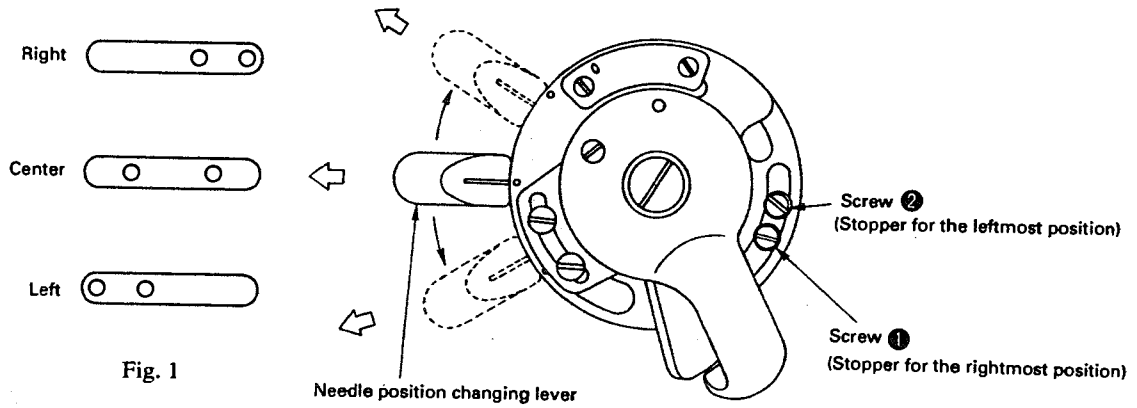
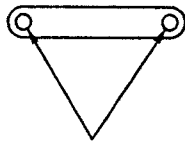

Fig. 1

LZ-2280



Leftmost/rightmost needle position should be aligned with the leftmost/rightmost needle entry for the max. zigzag width (5 mm).
(Perform the adjustment with the zigzag width set to "0.")

Fig. 2

LZ-2286

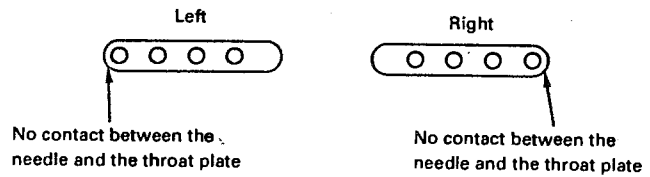

When the zigzag width is set to 8 mm, the needle should not come in contact with the throat plate at the leftmost and rightmost needle entry points.

Fig. 3

HOW TO ADJUST	RESULT OF IMPROPER ADJUSTMENT
<ul style="list-style-type: none"> ○ LZ-2280 (Fig. 2) <ol style="list-style-type: none"> 1. Set the zigzag width at "0." 2. Determine the limit the moving range of the needle position changing lever using screws ① and ② so that the leftmost rightmost needle position is aligned with the leftmost/rightmost needle entry of the max. zigzag width. ○ LZ-2286 (Fig. 3) <ol style="list-style-type: none"> 1. Set the zigzag width at "8." 2. Determine the limit the moving range of the needle position changing lever using screws ① and ② so that the needle does not come in contact with the throat plate at the leftmost and rightmost needle entry points. 	<ul style="list-style-type: none"> ○ If the needle goes beyond the leftmost/rightmost end of the max. zigzag width, thread breakage and stitch skipping will result. If the needle comes in contact with the throat plate, needle breakage will result.

STANDARD ADJUSTMENT

(12) Timing gauge

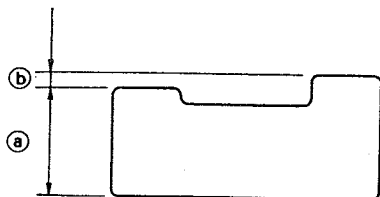

Engraved indication	Applicable model	Ⓐ	Ⓑ
LZ-2280	LZ-2280	13.4	2.7
LZ-2286	LZ-2286, -2287, -2285	12.8	3.1

(13) Needle bar height

Conditions : Zigzag width 0

Position of the needle position changing lever: Center

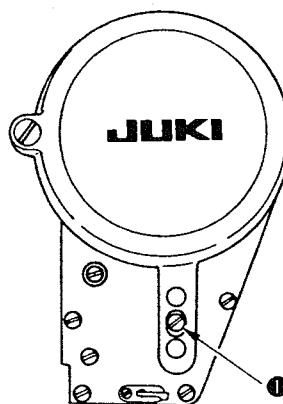
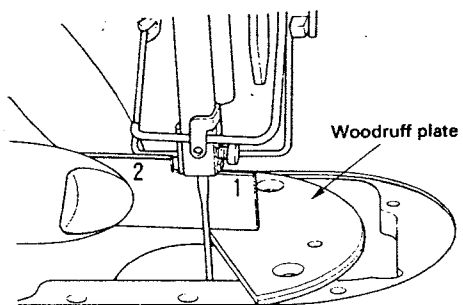

HOW TO ADJUST	RESULT OF IMPROPER ADJUSTMENT
<ul style="list-style-type: none"> ○ A timing gauge which is used for adjusting the needle bar height and needle-to-hook relation, are supplied with the machine as accessories. One side of the timing gauge, on which "1" is engraved, is used for adjusting the needle bar height. Another side of the timing gauge, on which "2" is engraved, is used for adjusting the needle-to-hook relation. Refer to "(13) Needle bar height" and "(14) Needle-to-hook relation" for detailed explanation describing how to use the timing gauge. 	
<ol style="list-style-type: none"> 1. Set the zigzag width at "0," and bring the needle to the center of the needle rocking stroke. 2. Remove the presser foot, throat plate, woodruff plate and feed dog. 3. Place the woodruff plate on the surface of the bed onto which the throat plate is to be attached. Now, loosen screw ① and adjust so that the distance from the top face of the woodruff plate to the bottom end of the needle bar is equal to the height of the "1" side of the timing gauge. <p>(Caution) Thickness of the throat plate is different from that of the woodruff plate. So, be sure to use the woodruff plate for the adjustment. (Thickness of the woodruff plate: 2 mm) Be sure to perform the adjustment with the zigzag width set at "0" and the needle positioned at the center of the right and left standard lines.</p>	

STANDARD ADJUSTMENT

(14) Adjusting the needle-to-hook timing and the needle guard

- Returning amount of the needle bar
 - LZ-2280 2.7 mm
 - LZ-2280 (LZ-2285)
 - LZ-2280 (LZ-2286) } 3.1 mm
 - LZ-2280 (LZ-2287)
- When the zigzag width is maximized, a distance of 0.2 to 0.5 mm should be provided between the top end of the needle eyelet and the blade point of the hook when the needle reaches the leftmost end of the zigzag stroke.

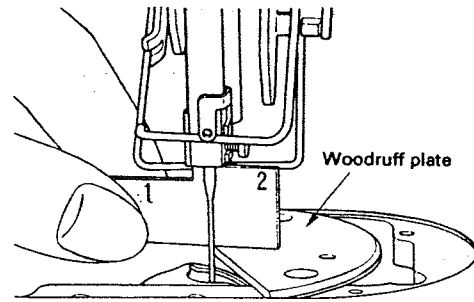
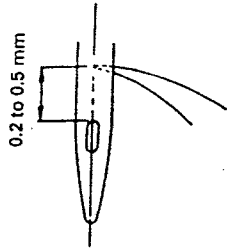

Fig. 1

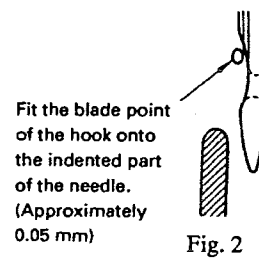

Fig. 2

- The needle guard must guard the needle both on the right-and left-hand sides.
- A clearance of 0 to 0.05 mm should be provided between the needle and the blade point of the hook (when the needle reaches the rightmost end of the zigzag stroke).

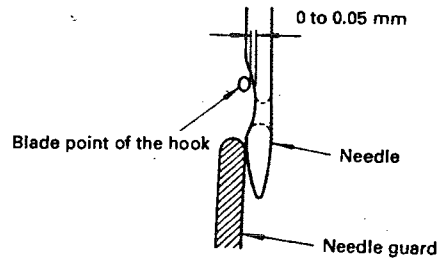
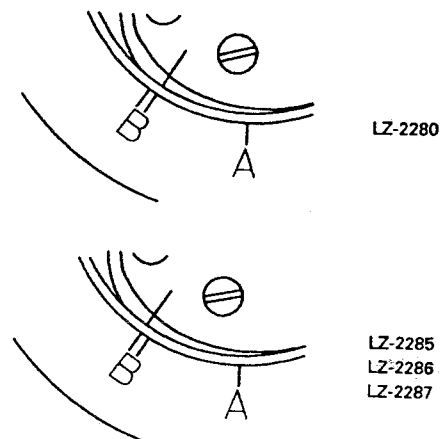

Fig. 3

[Remarks] Marker lines engraved on the face plate

- The needle-to-hook relation is adjusted using the timing gauge as described above. However, you can use the marker lines engraved on the face plate for reference when adjusting it.
- Use one of the marker lines B engraved on the face plate in accordance with the type of the sewing machine used as illustrated in the figure on the right.
- Be sure to remember that the marker lines are used only for reference. So, it is recommended to use the timing gauge for adjusting the needle-to-hook relation so as to make the most out of many functions of the LZ-2280 Series model of sewing machine.



HOW TO ADJUST	RESULT OF IMPROPER ADJUSTMENT
<p>1. After the needle bar height has been adjusted with the zigzag width set at "0," adjust so that the blade point of the hook is brought to the center of the needle using the timing gauge on which "2" is engraved. (Fig. 1)</p> <p>2. At this time, adjust so that the blade point of the hook slightly comes in contact with the needle when the needle guard does not come in contact with the needle (Fig. 2). Then tighten the screw in the hook.</p> <p>3. Maximize the zigzag width (LZ-2280: 5 mm, LZ-2286: 8 mm), and bend the needle guard so that it touches the needle both when the needle throws to the right and when it throws to the left. At this time, a clearance of 0 to 0.05 mm should be provided between the needle and the blade point of the hook when the needle throws to the right. (Fig. 3)</p> <p>(Caution) Use the hook that is exclusively used for the LZ-2280 Series. The part No. of the hook is 22524458. Designate the hook with the part No. when replacing it.</p>	<ul style="list-style-type: none"> ○ If the timing relation between the needle and the blade point of the hook is excessively advanced, smaller thread loops will be made particularly when the needle throws to the right or stitch skipping and thread breakage will result. ○ If the timing relation between the needle and the blade point of the hook is excessively retarded, larger thread loops will be made particularly when the needle throws to the left resulting in tilted thread loops and stitch skipping. ○ If the needle guard does not come in contact with the needle, the needle vibrates when the sewing machine runs at high speed resulting in thread breakage and stitch skipping. ○ If the needle comes in contact with the blade point of the hook, the blade point will be damaged resulting in an extraordinarily shortened service life of the hook.

STANDARD ADJUSTMENT

(15) Position of the bobbin case stopper

- The bobbin case stopper should be located within the range from the position at which top end **A** of the bobbin case stopper is aligned with line **B** to the position that is 0.5 mm away from line **B** in direction **C**.

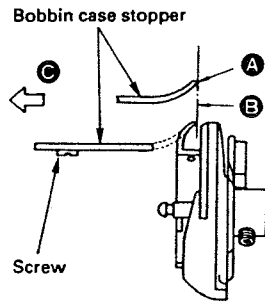

(16) Orientation of the needle bar thread holder

- The flat section on the needle bar and the eyelet in the needle bar thread holder should be faced toward the operator.

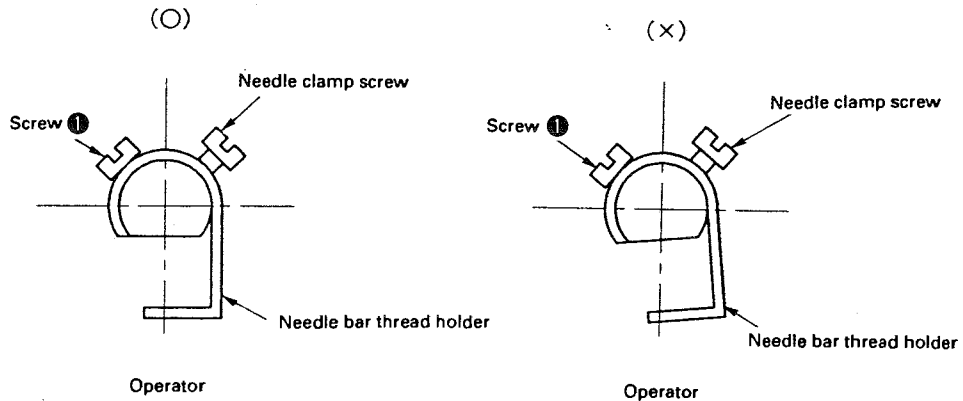

HOW TO ADJUST	RESULT OF IMPROPER ADJUSTMENT
<p>1. Loosen the screw and adjust the position of the bobbin case stopper by moving the entire unit of the bobbin case stopper.</p>	<ul style="list-style-type: none"> ○ If top end A of the bobbin case stopper goes beyond line E to the right, the thread may not smoothly come off the hook, resulting in thread breakage. ○ Adjusting the location of the bobbin case stopper by moving it in direction C, the thread will smoothly come off the hook. However, take care not to allow the thread to come off the hook when rotating the hook in the reverse direction.
<ul style="list-style-type: none"> ○ Loosen screw 1, and adjust the position of the needle bar thread holder with respect to the needle bar. ○ Loosen the screw in the needle bar connection, and adjust the orientation of the entire unit of the needle bar and needle bar thread holder. 	<ul style="list-style-type: none"> ○ If the orientation of the needle bar thread holder is not properly adjusted, the thread will be likely to untwist resulting in thread breakage.

STANDARD ADJUSTMENT

(17) Auxiliary thread take-up lever

o Vertical position

When the needle bar is in the lowest position of its stroke, the distance from the top end of the eyelet in the needle bar thread holder and the bottom end of the auxiliary thread take-up lever should be 0 to 1 mm.

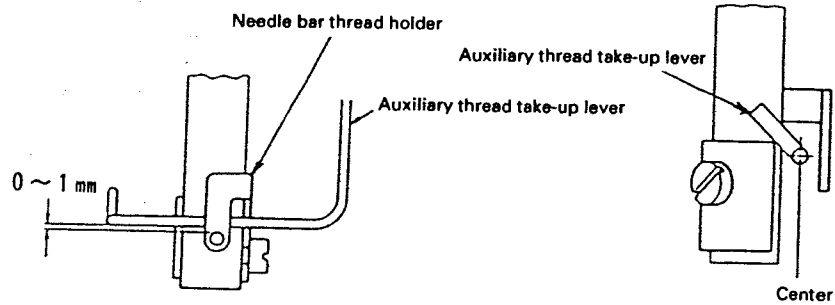

o Longitudinal position

The auxiliary thread take-up lever, as observed sideways, it moves the center of the needle and needle bar thread holder while keeping in parallel to the needle rocking stroke.

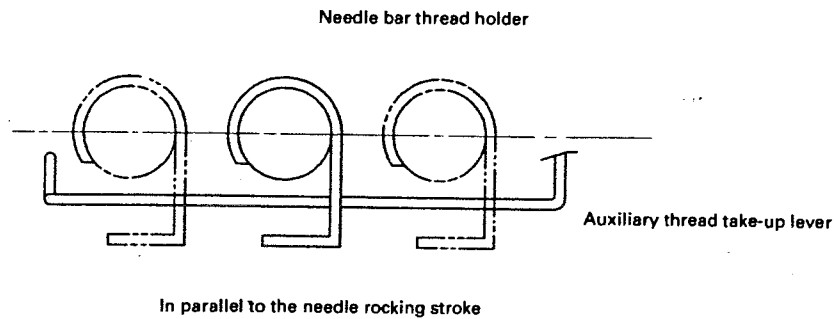

Even when the auxiliary thread take-up lever is positioned with its left-hand side raised, no problem will result. (O)

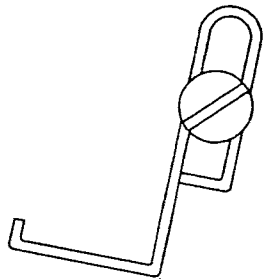

The position of the auxiliary thread take-up lever is not acceptable when it is positioned with its left-hand side lowered. (X)

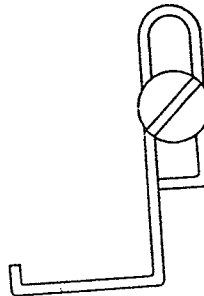

HOW TO ADJUST

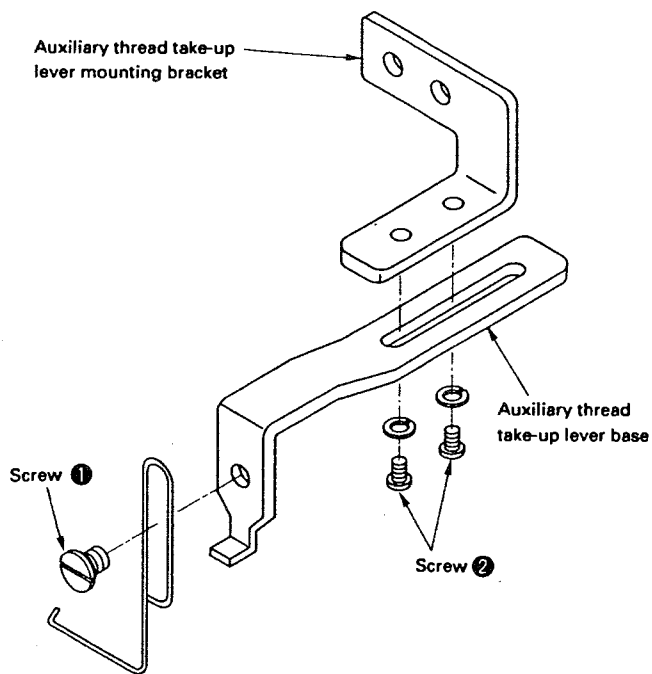

1. Loosen screw ①, and adjust the vertical position of the auxiliary thread take-up lever. At this time, carefully position the auxiliary thread take-up lever so that it is leveled or its left-hand side is raised.
2. Loosen screws ②, and adjust the longitudinal position of the auxiliary thread take-up lever. Use a thicker one of the hexagon wrench keys supplied with the machine as accessories. At this time, adjust so that the auxiliary thread take-up lever is in parallel to the needle rocking stroke and tighten the screws.

RESULT OF IMPROPER ADJUSTMENT

- If the auxiliary thread take-up lever is lowered from the correct vertical position, the thread take-up amount of the auxiliary thread take-up lever will be decreased and larger thread loops will be produced.
- If the auxiliary thread take-up lever is excessively raised from the correct vertical position, the auxiliary thread take-up lever will come in contact with the needle bar thread holder. So, be careful.
- If the longitudinal position of the auxiliary thread take-up lever is not proper or the auxiliary thread take-up lever is not in parallel to the needle rocking stroke, thread breakage and stitch skipping will be caused.

STANDARD ADJUSTMENT

(18) Position of the thread tension controller

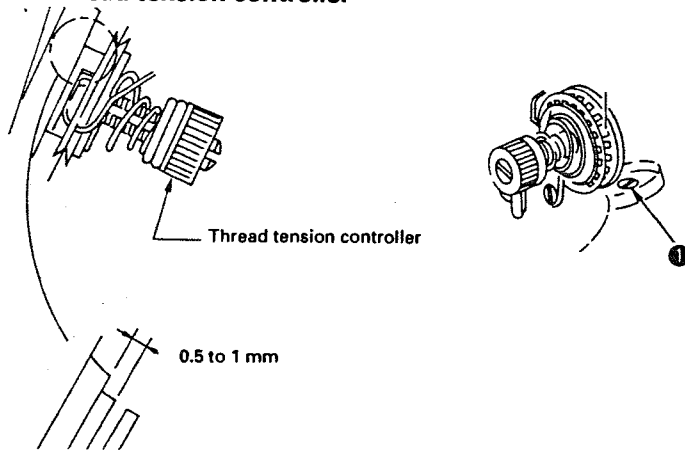

(19) Position of the pre-tension disk

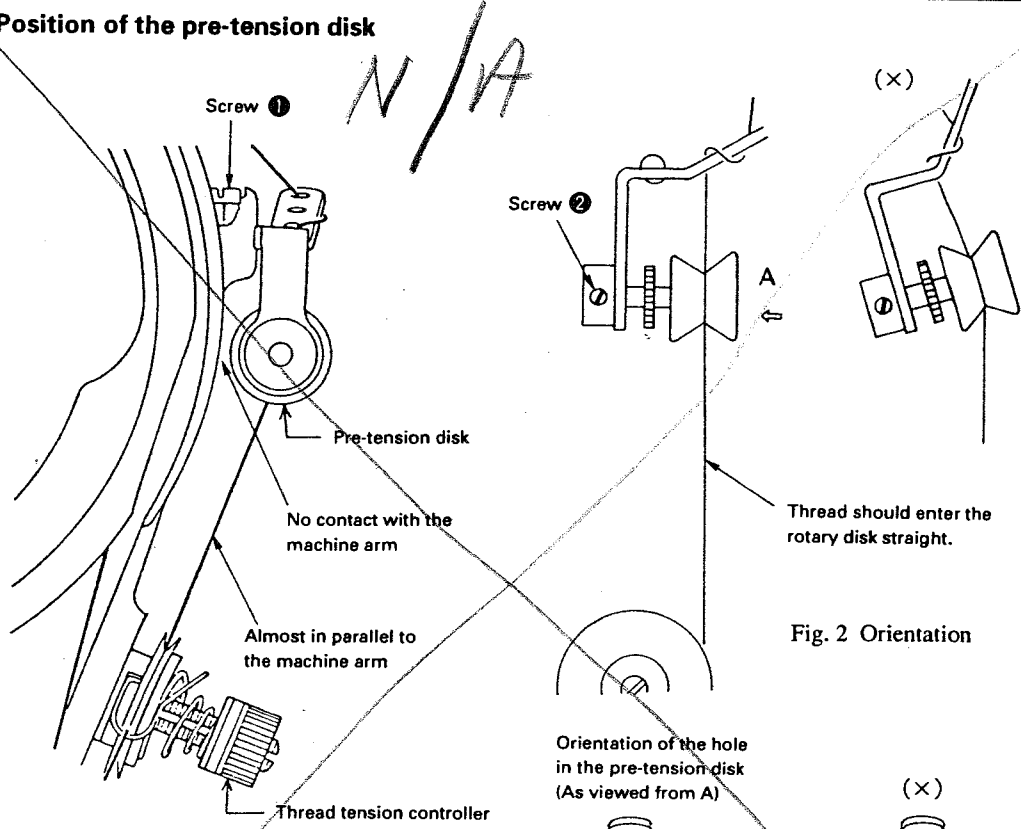

Fig. 1 Longitudinal position

Orientation of the hole in the pre-tension disk (As viewed from A)

The hole through which the thread passes must be perpendicular.

Fig. 3

HOW TO ADJUST	RESULT OF IMPROPER ADJUSTMENT
<ol style="list-style-type: none"> 1. Loosen screw ❶, and adjust the position of the thread tension controller. 2. Move the thread tension controller asm. back or forth to adjust so that the tension disk starts to rise when the presser foot goes up 4 mm from the lowest position referring to the dimensions shown in the figure given in the "Standard adjustment" column. 	<ul style="list-style-type: none"> ○ If the thread tension controller is excessively moved away from you, the tension disk will rise and no tension will be applied to the thread. ○ If the thread tension controller is excessively moved toward you, the tension disk will fail to rise when operating the knee-lifter.
<ol style="list-style-type: none"> 1. Loosen screw ❶, and adjust the longitudinal position of the pre-tension disk so that it does not come in contact with the machine arm and the thread is in parallel to the machine arm as illustrated in Fig. 1. 2. Adjust the orientation of the pre-tension disk so that the thread enters the rotary disk straight. 3. Loosen screw ❷, and adjust the orientation of the hole in the pre-tension disk is straight with respect to the thread. 	<ul style="list-style-type: none"> ○ If the pre-tension disk comes in contact with the machine arm, uniform tension will not be applied to the thread and the finished quality of seam will be impaired. ○ If the orientation of the pre-tension disk is not properly adjusted, the pre-tension disk will rise to cause irregular thread tension or slippage of the rotary disk. As a result, thread breakage and stitch skipping will be caused. ○ If the orientation of the hole in the pre-tension disk is not properly adjusted, the thread will be likely to slip off the pre-tension disk.

STANDARD ADJUSTMENT

(20) Adjusting the stroke of the thread take-up spring and the tension of the spring

Range of thread take-up amount 6 to 10 mm **7 mm**
 Tension 8 to 12 g

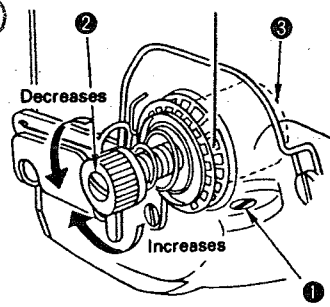

(21) Position of the thread take-up spring guard

In case of over-stroke of the thread take-up spring, the stopper rubber should securely support the spring.

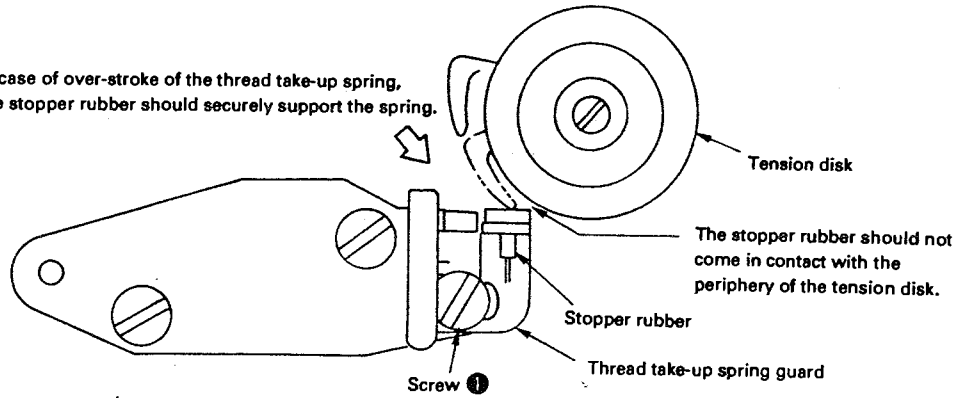

(22) Installing the take-up thread guide B

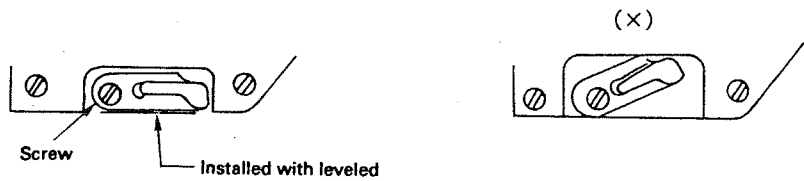

(23) Height and inclination of the feed dog

o Fix the thread take-up with pressed in the direction of rotation.

Position of Rotary Thread take-up Reassembly

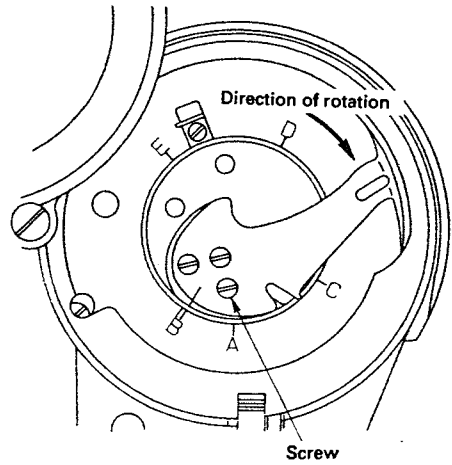

HOW TO ADJUST	RESULT OF IMPROPER ADJUSTMENT
<ol style="list-style-type: none"> 1. Securely tighten screw ❶ , and adjust the tension of the thread take-up spring by turning tension post ❷ while fitting a screwdriver in the groove on the tension post. 2. Loosen screw ❶ , and adjust the stroke of the thread take-up spring by turning entire unit ❸ of the tension controller asm. 	
<ul style="list-style-type: none"> ○ Loosen screw ❶ , and adjust the position of the thread take-up spring guard. 	
<ul style="list-style-type: none"> ○ Loosen the screw, and adjust the position of the take-up thread guide B. 	<ul style="list-style-type: none"> ○ If the take-up thread guide B is installed with faced upward, the thread will come in contact with the edge of the machine arm. This will adversely affect the quality of finished seam. 
<ul style="list-style-type: none"> ○ Slightly tighten the three screws. Then, securely tighten them with the thread take-up pressed in the direction of rotation. 	<ul style="list-style-type: none"> ○ If the thread take-up is not fixed taking the correct method, timing of the thread take-up with respect to the needle bar and the feed mechanism will change. This will change the feeling of finished seam or cause thread breakage.

STANDARD ADJUSTMENT

(24) Installation of the needle

- Tighten the needle clamp screw while pressing the needle always in the direction of the arrow (⇐).

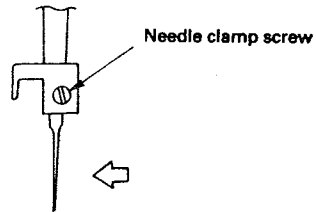

(25) Installation of the presser foot

- The top surface of the throat plate should be closely fitted on the reverse side of the presser foot.

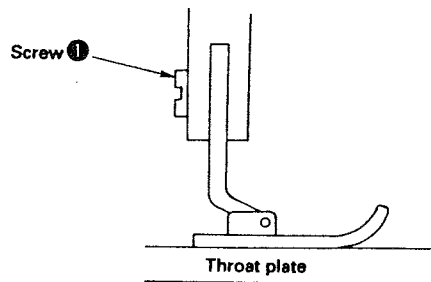

(26) Adjusting the presser foot pressure

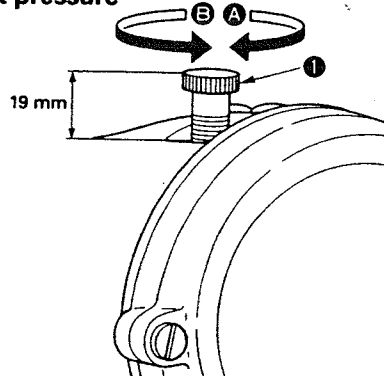

(27) Adjusting the micro-lifting mechanism

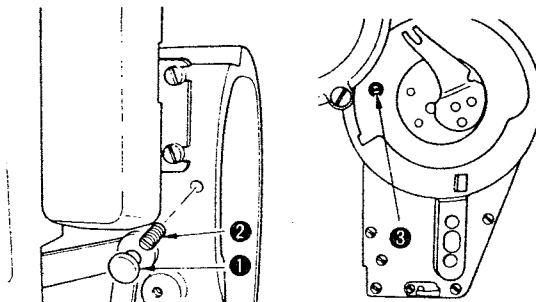

HOW TO ADJUST	RESULT OF IMPROPER ADJUSTMENT
<ul style="list-style-type: none"> ○ Install the needle as described in the “Standard adjustment” column so as to ensure that the optimal clearance is provided between the needle and the blade point of the hook. 	
<ol style="list-style-type: none"> 1. Put the presser foot in the presser bar, and insert screw ❶. At this time, do not tighten screw ❶. 2. Turn the handwheel until the feed dog descends under the top surface of the throat plate. 3. Applying a pressure onto the presser foot, tighten screw ❶ with the sole of the presser foot closely fitted on the top surface of the throat plate. 	<ul style="list-style-type: none"> ○ If the presser foot is not closely fitted on the throat plate, the material will not be fed straight and the material will flop causing thread breakage and stitch skipping.
<ol style="list-style-type: none"> 1. Turn presser spring regulator ❶ clockwise, i.e., in direction ❸ to increase the presser foot pressure. 2. Turn the presser spring regulator counterclockwise, i.e., in direction ❹ to decrease the presser foot pressure. 3. Generally, the standard height of the presser spring regulator is approximately 19 mm (to provide a presser foot pressure of approximately 3 kg). For the LZ-2285, the standard height of the presser spring regulator is approximately 27 mm (to provide a presser foot pressure of approximately 2.5 kg). 	
<ul style="list-style-type: none"> ○ Use the micro-lifting mechanism when the sewing should be performed with the presser foot slightly raised in accordance with the type of material to be used. The micro-lifting mechanism is adjusted in the procedure described below. 1) Remove cap ❶ for the rear side of the sewing machine and loosen screw ❷ in the micro-lifting mechanism. 2) Turn micro-lifting screw ❸ clockwise through the hole in the face plate until the presser foot is raised by the required amount. Then, tighten screw ❷. <p>(Caution) Be sure to return micro-lifting screw ❸ to the home position when the micro-lifting mechanism is not used.</p>	

STANDARD ADJUSTMENT

(28) Adjusting the amount of oil in the face plate

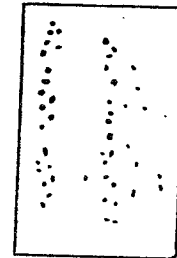
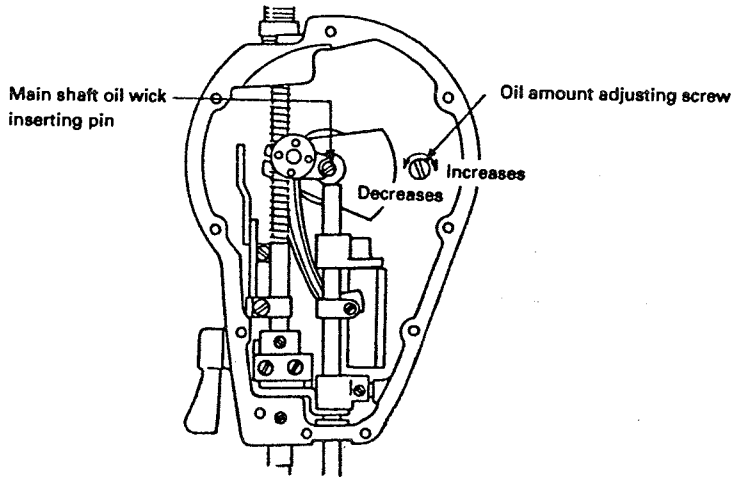

Oil spots on a sheet of paper while the machine is operating for 10 seconds (4,000 s.p.m.)

(29) Adjusting the amount of oil in the hook

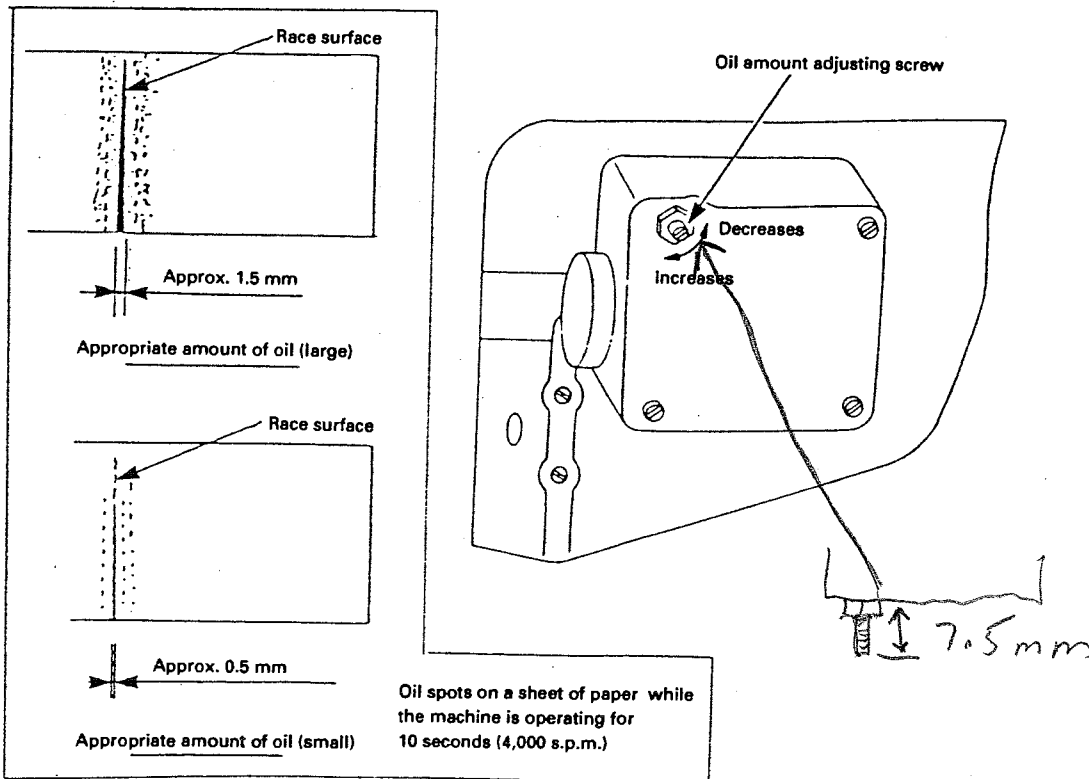

HOW TO ADJUST	RESULT OF IMPROPER ADJUSTMENT
<p>○ Turn the oil amount adjusting screw located inside the face plate, as illustrated in the figure, to adjust the amount of oil in the face plate.</p> <p>(Caution)</p> <ol style="list-style-type: none"> 1. Turn the oil amount adjusting screw by approximately 1/8 revolution (45°). 2. The amount of oil will not change immediately after the adjustment. So, measure the amount of oil in the face plate after turning the sewing machine for two or three minutes. 3. Lightly turn the oil amount adjusting screw. Never turn it strongly until the stopper is reached. 4. If the sufficient amount of oil is not smoothly fed to the face plate, remove the main shaft oil wick inserting pin that is tapped. Then, check whether the oil wick is correctly positioned. 5. Stain gathering on the surface of oil wick can be removed with gasoline by a certain extent. However, the oil wick is severely stained, replace it with a new one. Saturate an oil wick with lubricating oil before using it with the sewing machine. <p>Part No. of oil wick: B1810055200</p>	<p>○ If the amount of oil in the face plate is insufficient, the needle bar crank, needle bar crank rod and other face plate components will seize up. If the amount of oil in the face plate is excessive, oil leakage will result.</p>
<p>○ Adjust the amount of oil in the hook by turning the oil amount adjusting screw located on the rear side of the bed hook gear box.</p> <p>(Caution)</p> <ol style="list-style-type: none"> 1. Turn the oil amount adjusting screw by approximately 1/4 revolution (90°). 2. Lightly turn the oil amount adjusting screw. Never turn it strongly until the stopper is reached. 3. If the sufficient amount of oil is not smoothly fed to the hook, remove the oil wick pin, that is tapped, of the top end of the hook driving shaft. Then, check whether the oil wick is stained. 4. If the surface of the oil wick is severely stained, replace it with a new one. <p>Part No. of oil wick: 22523609</p>	<p>○ If the amount of oil in the hook is insufficient, loose stitches will result. Furthermore, the hook will be hot, likely to wear out or will seize up.</p> <p>○ If the amount of oil in the hook is excessive, the thread will be stained with oil. Furthermore, the material will also be stained with it.</p>

(22) Adjusting the amount of oil in the hook (ASS/-7, ASU/-7)

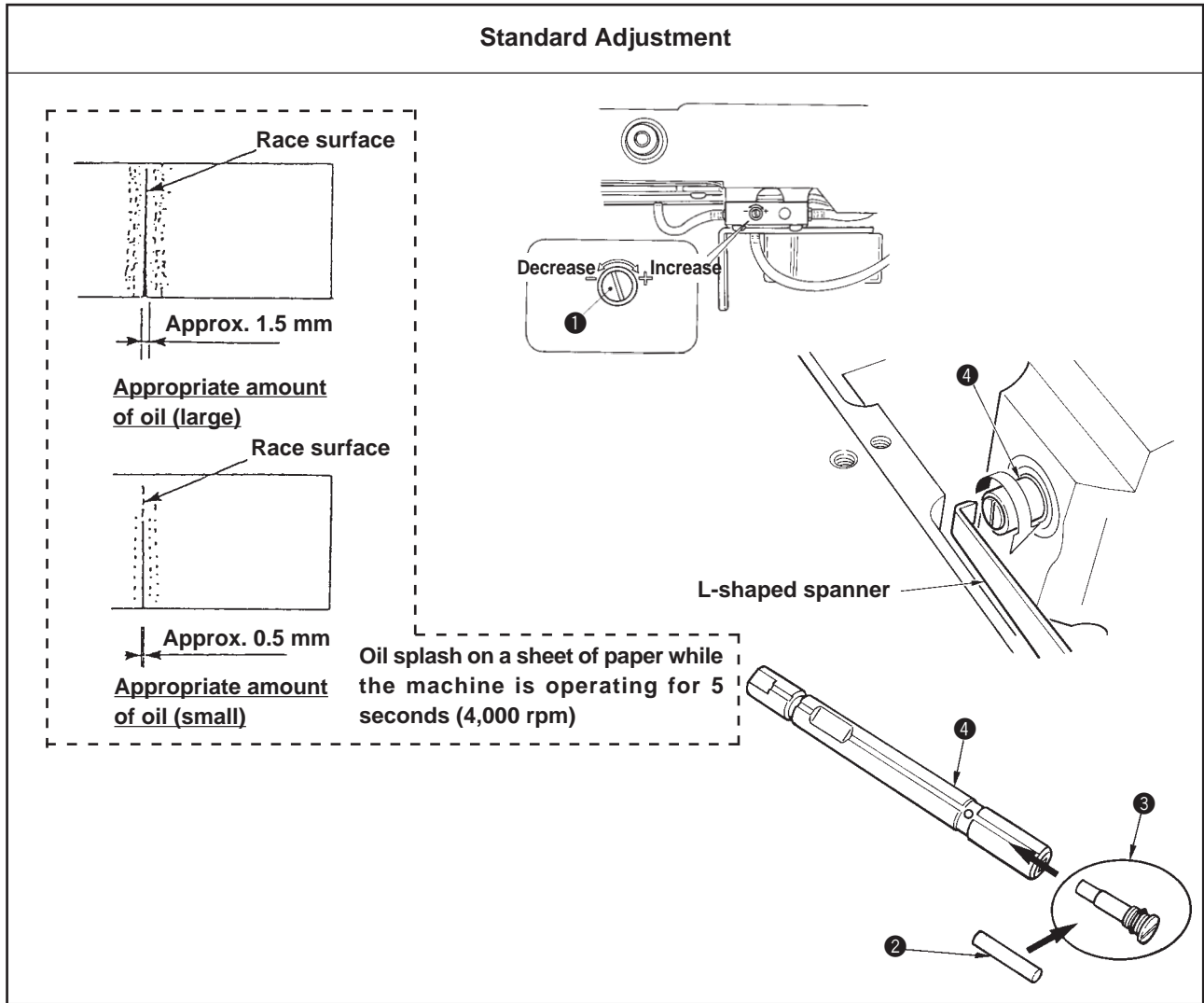

(23) Adjusting the thread trimming unit

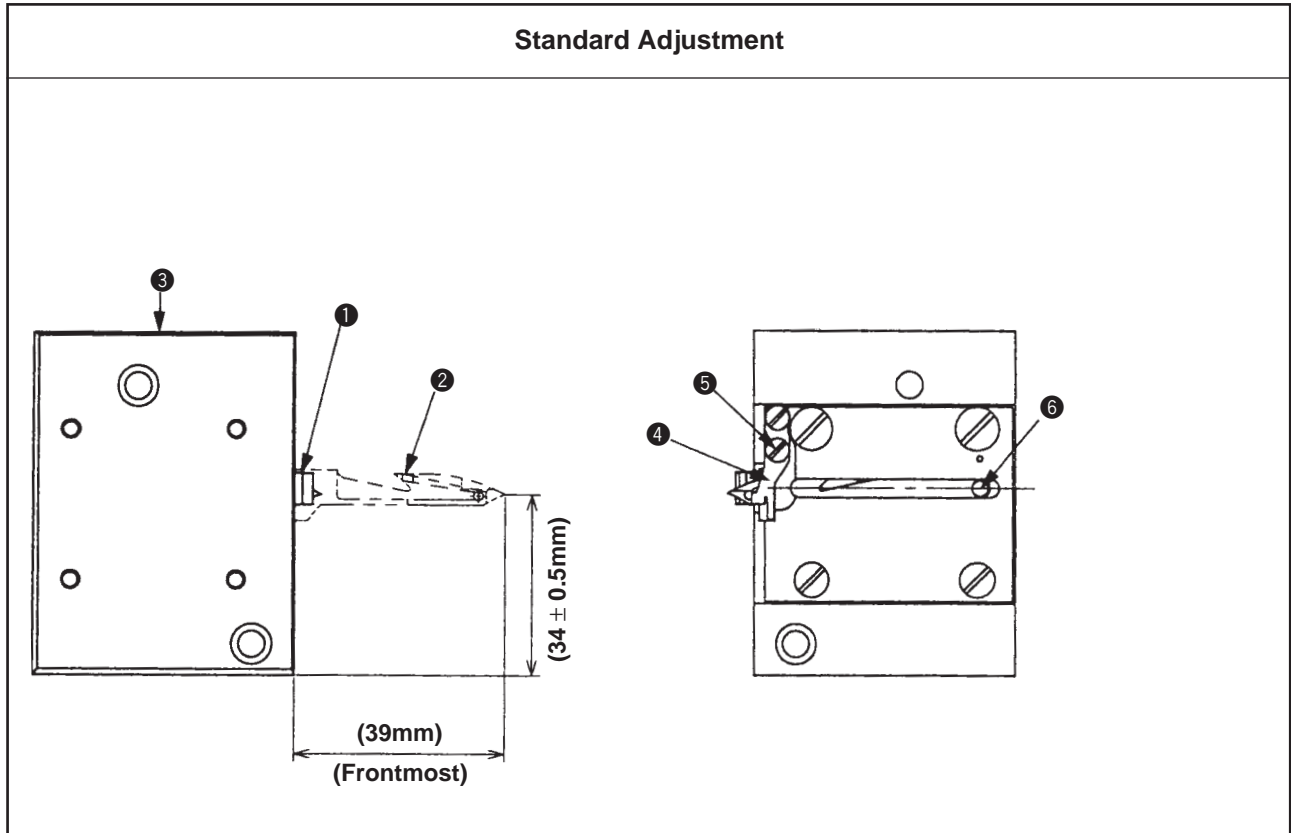

Adjustment Procedures	Results of Improper Adjustment									
<p>The amount of oil in the hook can be adjusted with oil amount adjusting screw ❶.</p> <p>1) Adjusting procedure Turning (clockwise) oil amount adjusting screw ❶ increases the oil amount in the hook and turning (counterclockwise) it decreases the oil amount in the hook.</p> <p>(Caution) 1. When adjusting the amount of oil in the hook, perform the adjustment in a way of reducing the oil amount after somewhat increasing it. 2. The amount of oil in the hook has been adjusted at the max. number of revolution at the time of delivery. When you always use the sewing machine at low speed, there is a possibility that trouble occurs due to the lack of amount of oil in the hook. When the sewing machine is used always at low speed, perform the adjustment of the amount of oil in the hook.</p> <p><<Replacing procedure of hook shaft oil wick>></p> <p>1) Hook shaft oil wick ❷ is a consumable part. To stabilize the oil amount in the hook, it is recommended to periodically replace it. Hook shaft oil wick ❷ is mounted on the top end of hook shaft ❹. Remove the needle and the parts around the needle (presser foot, needle, throat plate, feed dog, hook and woodruff plate), put a spanner, top end of which is L-shaped to screw ❸ section of hook shaft oil wick, turn the handwheel in the normal direction of rotation by hand, and draw out the screw. It is possible to replace hook shaft oil wick ❷ while hook shaft ❹ is not removed. If hook shaft ❹ is drawn out, refer to 5-(9) Protruding amount of the hook shaft.</p> <p>2) Hook shaft oil wick screw ❸ (B1808552000) in which hook shaft oil wick ❷ (11015906) is entered is assembled in hook shaft ❹. Draw out the old hook shaft oil wick ❷ in hook shaft oil wick screw ❸ and push a new hook shaft oil wick ❷. At this time, be sure to check that hook shaft oil wick ❷ has entered up to the end of hook shaft oil wick screw ❸.</p> <ul style="list-style-type: none"> When re-assembling, check that the hole at the top end of hook shaft oil wick screw ❸ is not broken. <p>3) Assemble hook shaft oil wick screw ❸ to the top end of hook shaft ❹.</p> <table border="1" data-bbox="290 1115 847 1225"> <thead> <tr> <th></th> <th>Name of part</th> <th>Part No.</th> </tr> </thead> <tbody> <tr> <td>❷</td> <td>Hook shaft oil wick</td> <td>11015906</td> </tr> <tr> <td>❸</td> <td>Hook shaft oil wick screw</td> <td>B1808552000</td> </tr> </tbody> </table>		Name of part	Part No.	❷	Hook shaft oil wick	11015906	❸	Hook shaft oil wick screw	B1808552000	<ul style="list-style-type: none"> When oil wick is stained, decrease of oil amount in the hook or unstableness of oil amount will result. When hook shaft oil wick ❷ is not entered up to the end of hook shaft oil wick screw ❸, hook shaft oil wick screw ❸ comes off during operation and the oil amount in the hook cannot be adjusted. Besides, hook shaft oiling inlet is closed and oil amount in the hook is hard to be obtained. When the hole is broken, replace the screw with a new one. Oil amount in the hook becomes unstable.
	Name of part	Part No.								
❷	Hook shaft oil wick	11015906								
❸	Hook shaft oil wick screw	B1808552000								

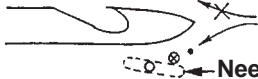
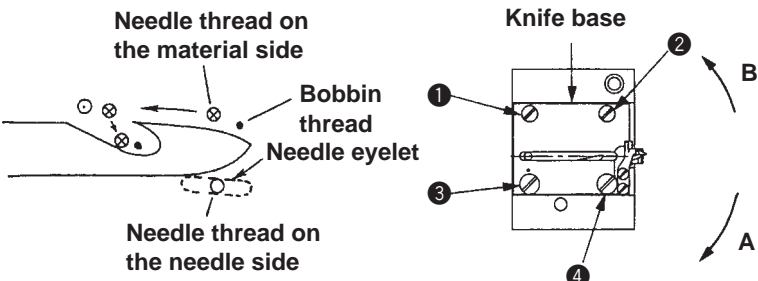
Adjustment Procedures	Results of Improper Adjustment
<ol style="list-style-type: none"> Move moving knife ❷ forward until it will go no further (by approximately 39 mm) and confirm that the end of slide plate ❸ is spaced 34 ± 0.5 mm from the top of the moving knife ❷. Adjust the operating pressure of counter knife ❶ and moving knife ❷ by tightening screw ❸ in clamp plate ❹. At this time, the force to move moving knife pin ❺ in the direction of the arrow is more or less than 600 gf. If screw ❸ is excessively loose, defective thread trimming may occur. 	<ul style="list-style-type: none"> When the moving knife is positioned in the front : 1) In the case where the needle thread is trimmed twice :  Needle eyelet When the moving knife is positioned in the rear : 2) In the case where the needle thread is not trimmed :  Needle eyelet
<ul style="list-style-type: none"> When the moving knife is properly positioned :  	<p>How to solve the aforementioned troubles</p> <ol style="list-style-type: none"> In the case where the needle thread is trimmed twice : Slightly loosen screws ❶ to ❹, and slant the knife base in the direction A. Then tighten screws ❶ to ❹. In the case where the thread is not trimmed : Slightly loosen screws ❶ to ❹, and slant the knife base in the direction B. Then tighten screws ❶ to ❹.

(24) Initial position of the moving knife

Standard Adjustment

- Moving knife pin ① should be aligned with marker dot ②.
- Acceptable range of the position of moving knife is as wide as the marker dot.

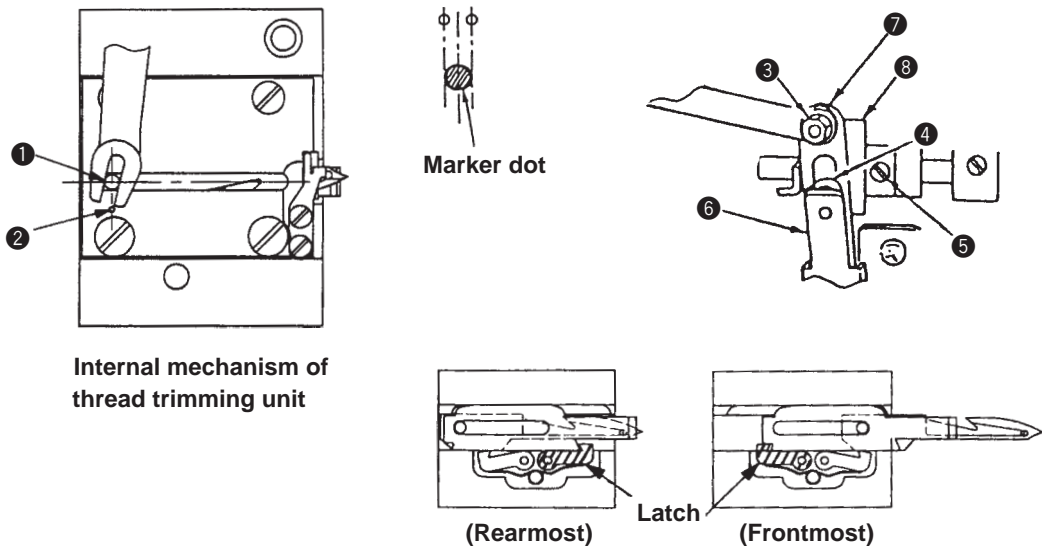

(25) Timing of the thread trimming cam

Standard Adjustment

(See the figure shown above.)

- Press roller arm ⑥ until roller ④ fits in the groove in thread trimming cam ⑧. Now, lightly turn the main shaft handwheel carefully in the reverse direction until it stops. At this time, the marker dot engraved on the machine arm should be aligned with the red marker dot engraved on the handwheel. Adjust the thread trimming cam longitudinally within the width of a dot.

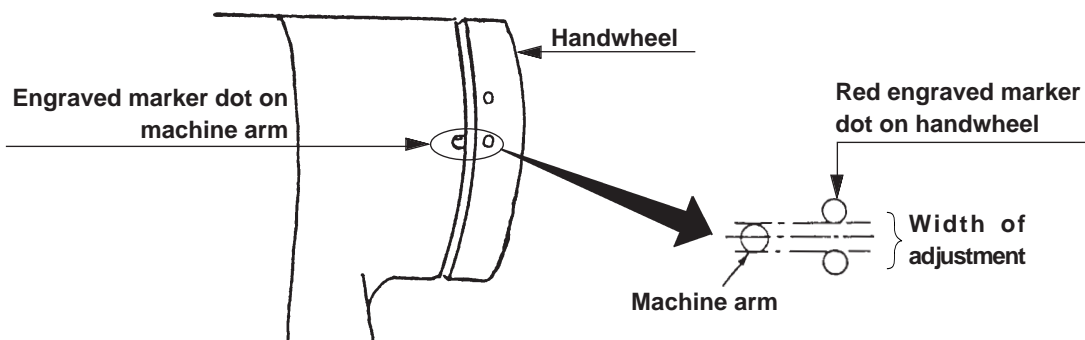

Adjustment Procedures	Results of Improper Adjustment
<p>1) Loosen nut ③ in the knife driving arm ⑦ , and adjust the initial position of the moving knife. Loosen/tighten nut ③ after roller ④ has fitted in the groove on the thread trimming cam ⑧ by pressing roller arm ⑥ with fingers. This will prevent knife driving arm ⑦ from moving out of position thereby allowing you to perform the adjustment in safety.</p> <p>2) After adjusting the initial position of the moving knife, turn the handwheel in the state that roller ④ has fitted in the groove on the thread trimming cam ⑧ , and check that the latch has securely entered when the moving knife moves forward or backward until it will go no further. (You can hear “click” when the latch has entered.)</p> <p>(Caution) When a feed dog other than that which is delivered as standard is used, there is a case where the feed dog interferes with counter knife according to its shape. In case of interference, move the feed dog to the left side from the engraved dot and check that there is no interference with each other.</p>	<ul style="list-style-type: none"> ○ If the initial position of the moving knife is not properly adjusted, the moving knife will fail to cut the thread or cut the thread at a wrong position reducing the length of remaining thread after thread trimming.

Adjustment Procedures	Results of Improper Adjustment
<p>If the timing of the thread trimming cam is not correct, adjust it in the following steps of procedure.</p> <p>1) Loosen two screws ⑤ in the cam.</p> <p>2) Turn the main shaft handwheel until the red marker dot engraved on the handwheel is aligned with the marker dot engraved on the machine arm.</p> <p>3) Push roller arm ⑥ until roller ④ fits in the groove in thread trimming cam ⑧. Lightly push thread trimming cam ⑧ on the handwheel side and turn it in the reverse direction until it will go no further. Now, tighten two screws ⑤ in the cam.</p>	<ul style="list-style-type: none"> ○ If the timing of the thread trimming cam is excessively advanced, the knife will fail to cut the thread or the length of the thread remaining after thread trimming will be decreased resulting in slip-off of the thread. ○ If the timing of the thread trimming cam is excessively retarded, the knife will fail to cut the thread or the moving knife will fail to fully return to the home position making the moving knife projects at the start of sewing.

(26) Installing/removing the knife unit

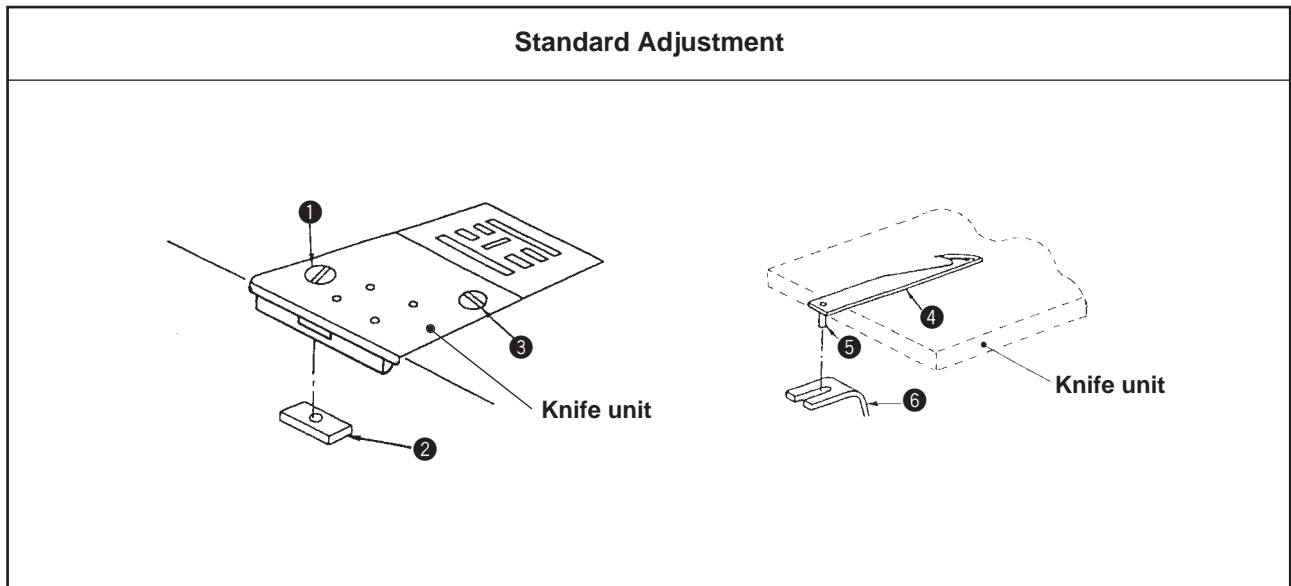

(27) Stop position of the needle after thread trimming (Needle UP stop)

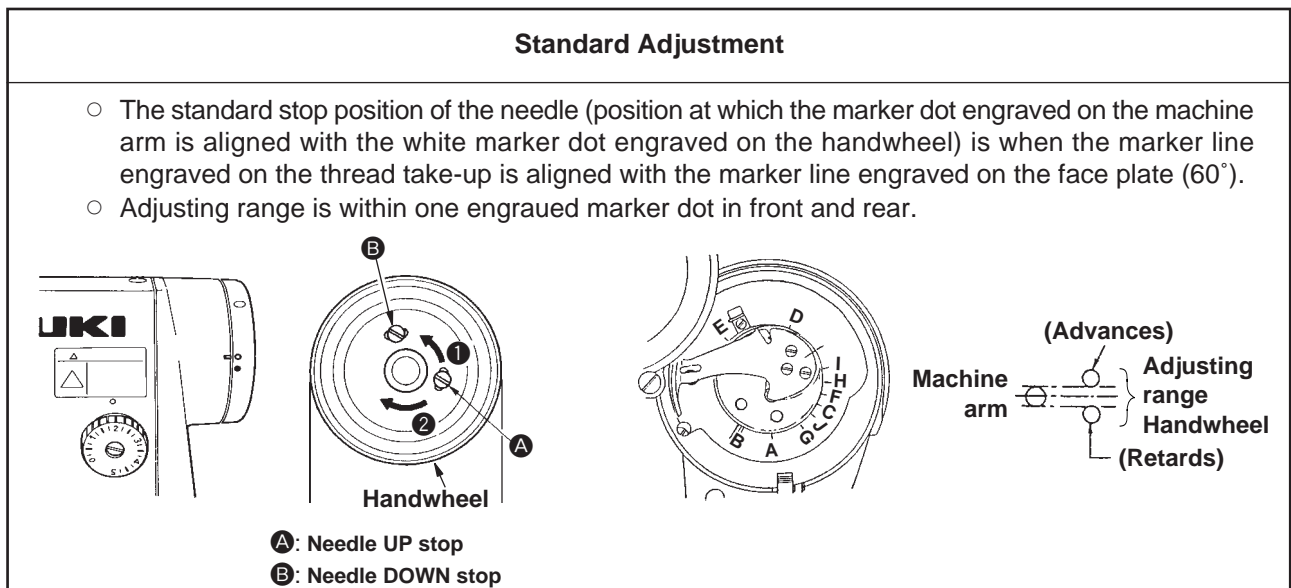

(28) Clearance provided between the main shaft handwheel and the stator

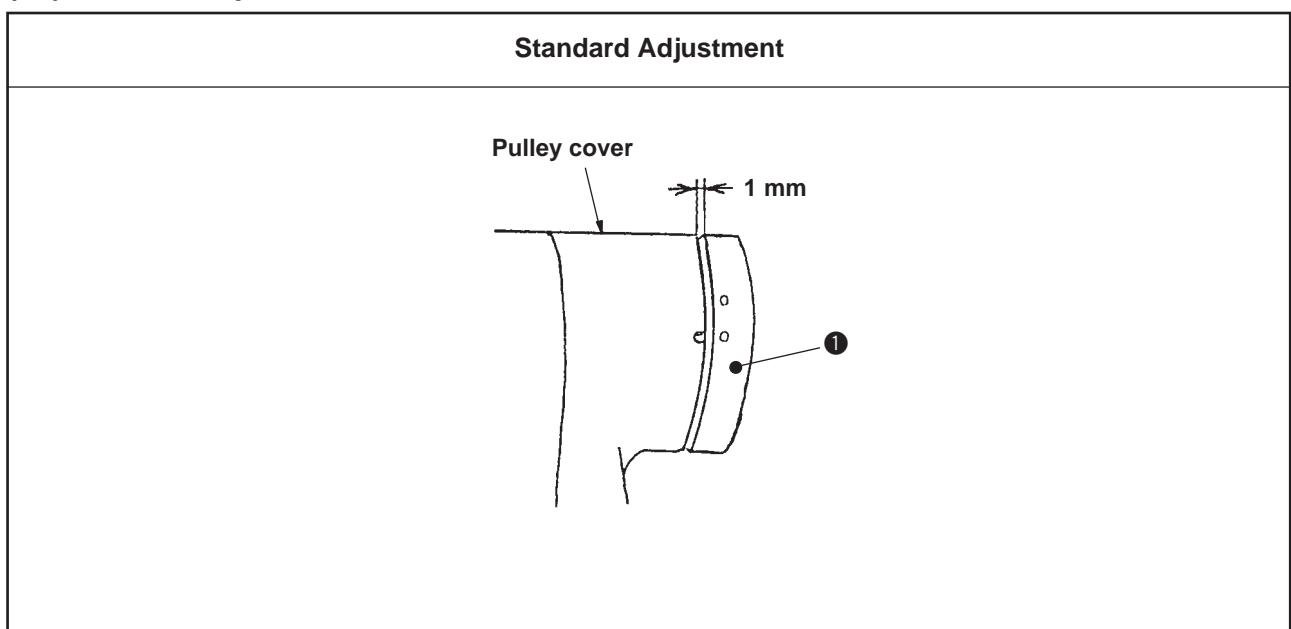

Adjustment Procedures	Results of Improper Adjustment
<p>1) Loosen screw ❶ and remove fixing plate ❷.</p> <p>2) Remove screw ❸, and the knife unit will come off. Installation is carried out analogously in reverse order.</p> <p>(Caution) When installing the knife unit, take care to allow pin ❺ of moving knife (asm.) ❹ to securely rest on knife yoke (asm.) ❻.</p>	

Adjustment Procedures	Results of Improper Adjustment
<p>1) Stop the needle in its upper stop position. Loosen screw ❶ in the figure and adjust the stop position of the needle by moving the screw within the slot.</p> <ul style="list-style-type: none"> ○ To advance the stop position ➡ in the direction ❶ ○ To retard the stop position ➡ in the direction ❷ <p>2) For the lower stop position of the needle, stop the needle in its lower stop position, loosen screw ❷ and adjust the stop position within the slot.</p> <p>(Caution)</p> <ol style="list-style-type: none"> 1. Do not rotate the sewing machine with screws ❶ and ❷ loosened during performing adjustment. 2. Be sure only to loosen screws ❶ and ❷ and not to remove them. 3. Do not adjust needle DOWN stop screw ❷. 	<ul style="list-style-type: none"> ○ When the stop position retards, there is a possibility that wiper interferes with needle in case of with wiper.

Adjustment Procedures	Results of Improper Adjustment
<p>1) Provide a clearance of 1 mm between handwheel ❶ and the pulley cover. If the clearance is excessively narrow, the position detecting magnet comes in contact with the synchronizer, and if it is excessively wide, defective detection may occur.</p> <p>2) Be sure to adjust screw No. 1 in the handwheel ❶ to the flat portion of the motor shaft and tighten the screws in the order of No. 1 and No. 2.</p>	

STANDARD ADJUSTMENT

(36) Position of the one-touch type reverse stitching switch lever

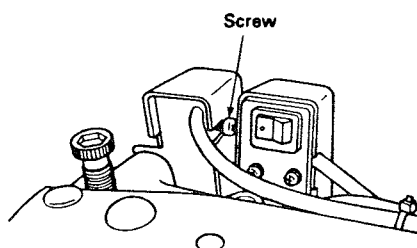

(37) Position of the automatic reverse stitching magnet

- When the zigzag width is maximized (LZ-2280: 2.5 mm, LZ-2286, -2287: 2 mm), press down the feed lever until the plunger moves in the direction of the arrow (→). At this time, the rubber cushion should turn while being applied with a little load.

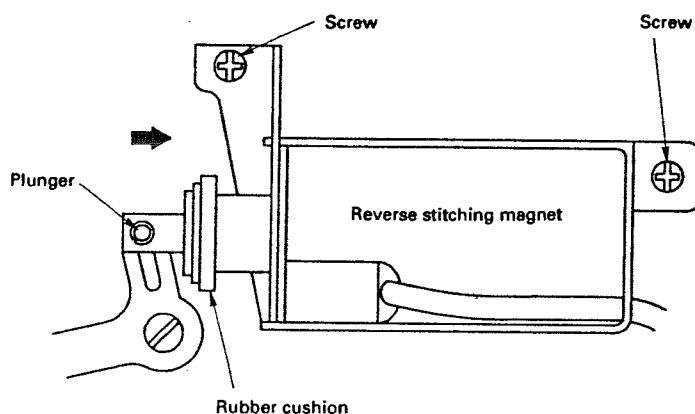

(38) Installing the thread tension releasing solenoid and adjusting it

- The presser plate of the thread tension releaser should be engaged with the roll pin and the auxiliary pin of the thread tension releaser.
- When the solenoid is pushed with fingers in direction A, it should move smoothly. Also when the solenoid is released, it should smoothly return to its home position.
- When the solenoid is pushed in direction A, the tension disk should rise.

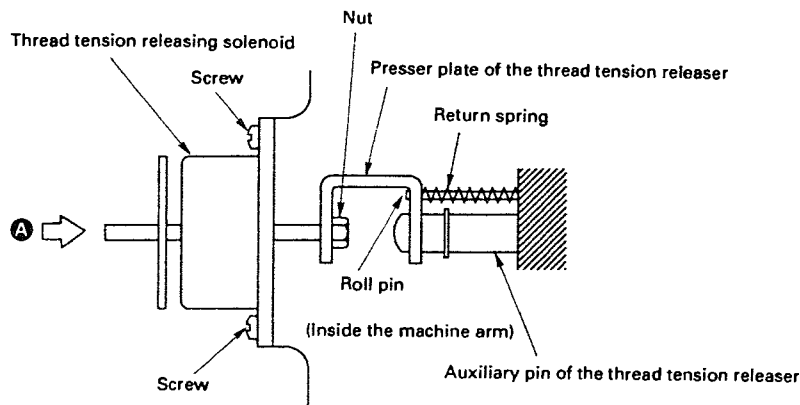

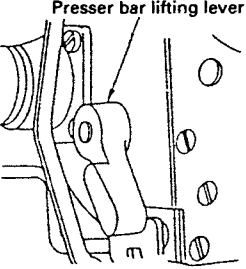
HOW TO ADJUST	RESULT OF IMPROPER ADJUSTMENT
<ul style="list-style-type: none"> Loosen the screw, and adjust the height of the switch lever so that you can operate it with ease. 	
<ul style="list-style-type: none"> Loosen the two screws. Adjust the position of the automatic reverse stitching magnet by moving it. 	
<ol style="list-style-type: none"> To install the thread tension releasing solenoid, lower the presser bar lifting lever and adjust so that the solenoid is engaged with the roll pin and the auxiliary pin while making the solenoid straddle the lifting plate. Then, tighten the four screws. At this time, be sure to confirm that the return spring is fitted in position.  If the thread tension releasing solenoid fails to move smoothly when it is pressed in direction A, loosen the four screws and adjust the center of the solenoid. If the tension disk fails to rise when the thread tension releasing solenoid is pressed in direction A, check first the position of the thread tension controller, then remove the solenoid. Then, loosen the nut and adjust the position of the presser plate of the thread tension releaser. 	<ul style="list-style-type: none"> If the thread tension releasing solenoid fails to be engaged with the auxiliary pin of the thread tension release, the tension disk will not rise at the time of thread trimming resulting in slip-off of the thread. If the thread tension releasing solenoid fails to be engaged with the roll pin, the return spring is not fitted in position, or the solenoid fails to smoothly return to its home position, the tension disk will be held raised after thread trimming.

STANDARD ADJUSTMENT

(39) Adjusting the installed state of the stopper plate

- The stopper plate should be installed with leveled.

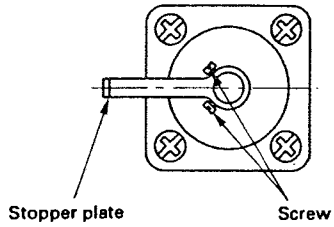

- The top end of stopper plate should be flush with the top surface of the thread feeding lever. When the thread tension releasing solenoid is actuated, the stopper plate should come off the thread feeding lever.

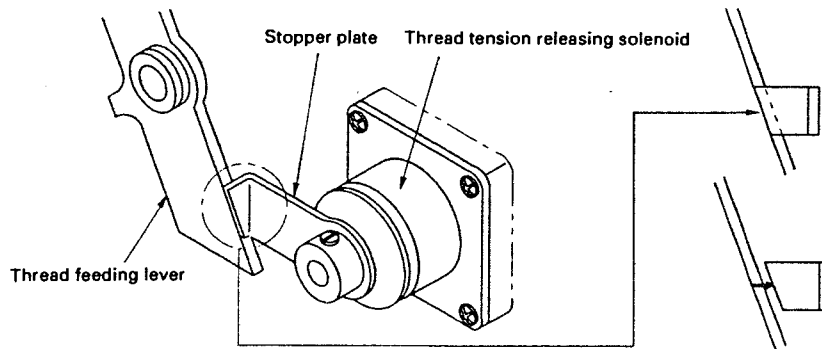

(40) Position of the needle thread feeding device

- When the returning solenoid is actuated (when the plunger is pressed in direction A), clearance F of 0.5 to 1 mm should be provided.

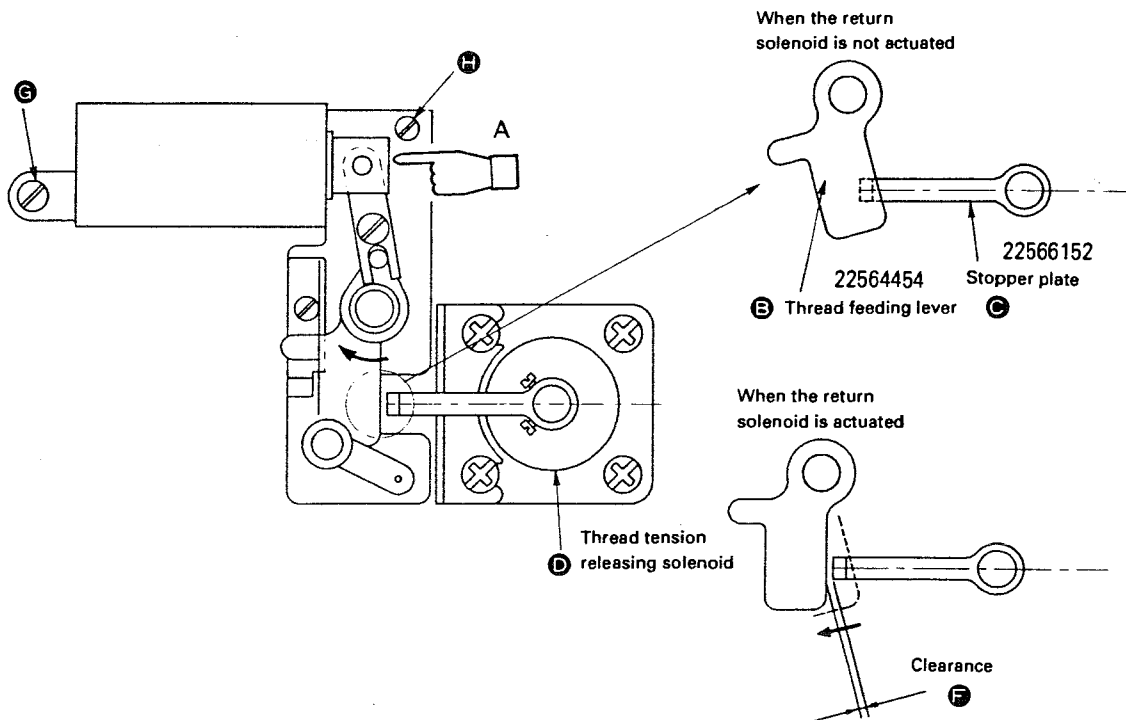

HOW TO ADJUST	RESULT OF IMPROPER ADJUSTMENT
<p>○ Loosen the two screws and adjust the installed state of the stopper plate while observing how far the plate overlaps the thread feeding lever and checking levelness of the plate. If the stopper plate fails to come off the thread feeding lever, reduce the overlapping depth of the stopper plate with respect to the thread feeding lever.</p> <p>However, note that the stopper plate should be overlap the thread feeding lever at least by a half of thickness of the lever. (The overlapping depth should be a half of thickness of the thread feeding lever or more, but should not exceed the full thickness.)</p> <div data-bbox="636 604 872 861" data-label="Diagram"> <p style="text-align: center;">Overlapping depth</p> <p style="text-align: center;">Thickness</p> </div>	<p>○ If the stopper plate fails to come off the thread feeding lever when the thread tension releasing solenoid is actuated, the needle thread feeding device will not operate at the time of thread trimming. As a result, stitch skipping and slip-off of the needle thread will occur at the start of sewing.</p>
<p>○ If the clearance provided between the stopper plate and the thread feeding lever is smaller than the specified value or no clearance is provided between them, loosen screws ③ and ④ and adjust so that the specified clearance is obtained between the stopper plate and the thread feeding lever by moving the entire unit of the needle thread feeding device to the left.</p> <p>Confirm that, when the plunger of the return solenoid is moved in direction A, thread feeding lever ⑤ turns counterclockwise until it properly overlaps the leftmost section of stopper plate ⑥, and stopper plate ⑥ and thread tension releasing solenoid ⑦ respectively return to the home position.</p>	<p>○ If the clearance between the stopper plate and the thread feeding lever is smaller than the specified value or no clearance is provided between them, they will not return to the home position after the needle thread feeding device has operated.</p>

STANDARD ADJUSTMENT

(41) Adjusting the position of the thread feeding wire

- Distance between the arm thread guide A and the thread feeding wire (in the figure given below): 8 to 12 mm

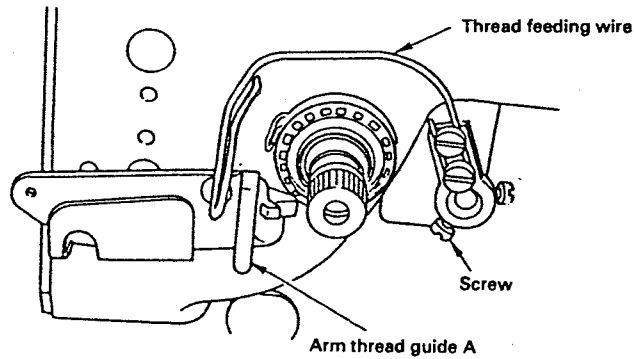

- The arm thread guide A should not come in contact with the thread feeding wire.

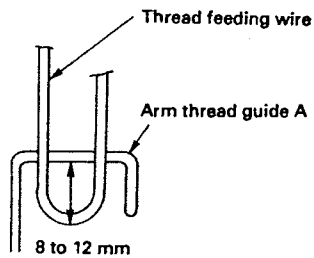

(42) Adjusting the stroke of the thread feeding wire

- Distance between the arm thread guide A and the thread feeding wire when the thread feeding wire operates in direction A: 16 to 18 mm

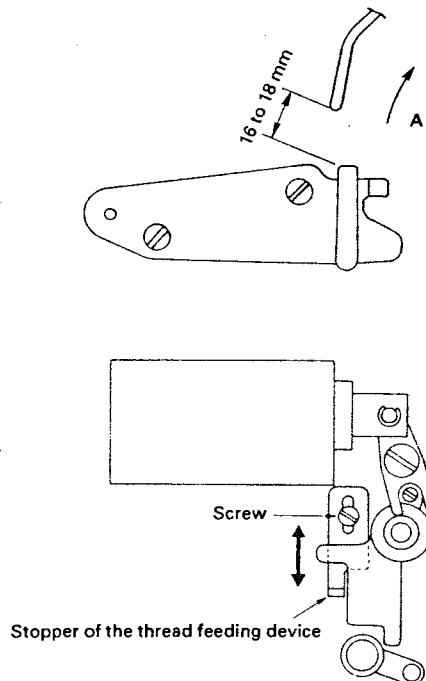

HOW TO ADJUST	RESULT OF IMPROPER ADJUSTMENT
<ul style="list-style-type: none"> ◦ Loosen the two screws. Adjust the position of the thread feeding wire by moving it back or forth and in the direction of rotation. 	<ul style="list-style-type: none"> ◦ If the arm thread guide A comes in contact with the thread feeding wire, the thread feeding wire may fail to operate.
<ul style="list-style-type: none"> ◦ The figure shown in the “Standard adjustment” column illustrates the thread feeding wire when the thread tension releasing solenoid is actuated (by pressing it by hand referring to (38) on page 36) and the thread feeding wire operates. To adjust the distance from the thread feeding wire to the arm thread guide A to 16 to 18 mm, loosen the screw and adjust the position of the stopper. Lifting the stopper will increase the stroke of the thread feeding wire. Lowering the stopper will decrease it. 	<ul style="list-style-type: none"> ◦ If the stroke of the thread feeding wire is insufficient, the length of the needle thread remaining after thread trimming will be reduced resulting in stitch skipping and slip-off of the thread at the start of sewing. If the stroke of the thread feeding wire is excessive, thread breakage will occur at the start of sewing.

STANDARD ADJUSTMENT

(43) Installing the wiper base

- As observed from the operator, the wiper should be leveled.

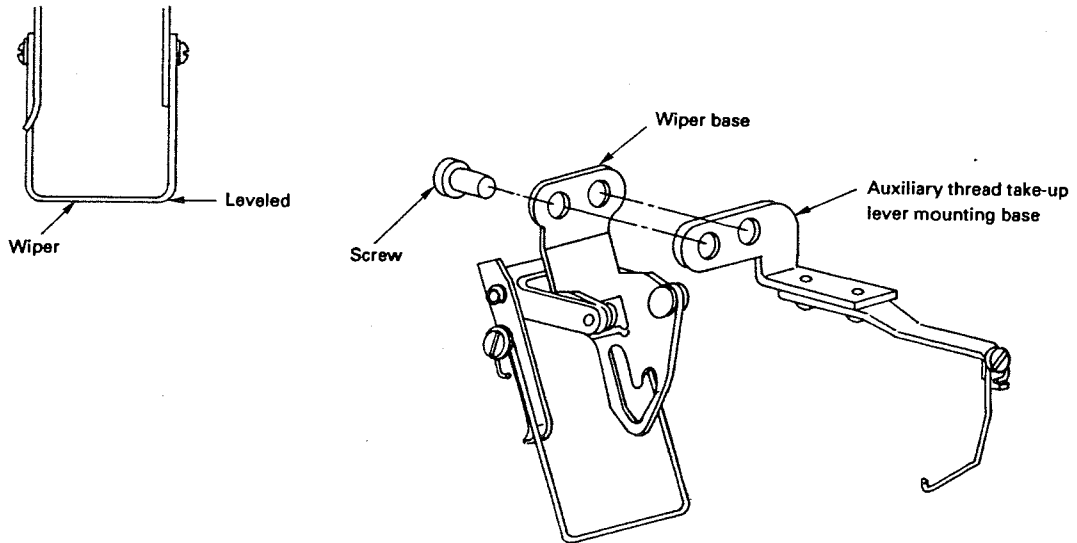

(44) Adjusting the wiper solenoid

- When the wiper solenoid is not actuated (in the normal state), the pin should be lightly fitted onto the leftmost end of the slot while providing no clearance between them. (State **A**)
Confirm that the pin comes in contact with the rightmost end of the slot at position **C** when the wiper solenoid is actuated (when it is pressed in direction **E**).

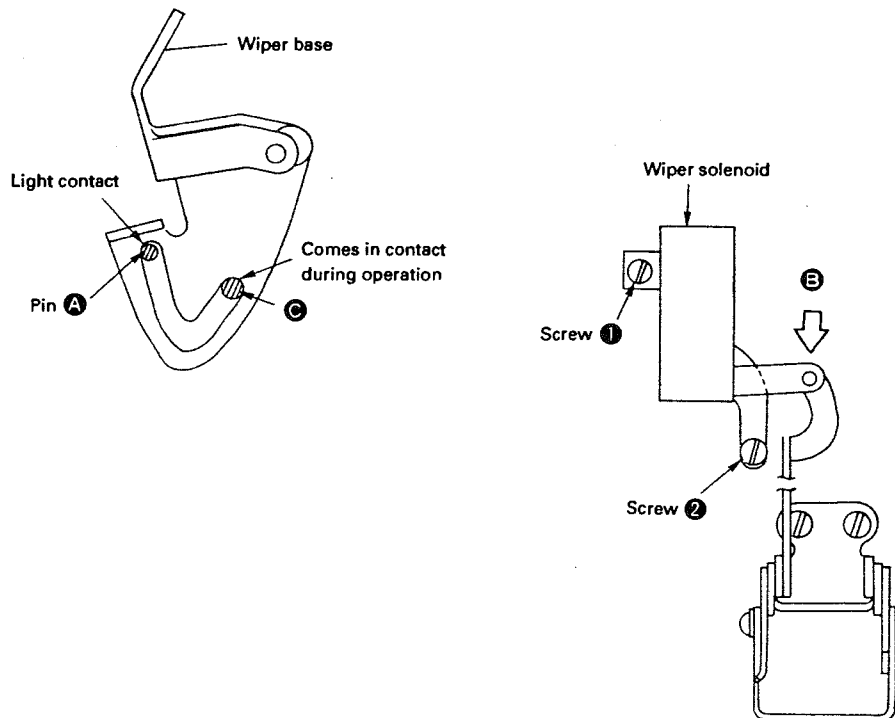

HOW TO ADJUST	RESULT OF IMPROPER ADJUSTMENT
<p>○ Loosen the two screws and adjust the installing position of the wiper base.</p> <p>The screws are used commonly to fix the wiper base and auxiliary thread take-up lever mounting base. So, it is necessary to adjust the installed state of the wiper base while checking the respective bases for inclination and torsion.</p>	
<p>○ Loosen screws ① and ② when the solenoid is not actuated. Adjust so that the pin is lightly fitted onto the leftmost end of the slot while providing no clearance between them (state ④) by moving the entire unit of solenoid up or down.</p>	

STANDARD ADJUSTMENT

(45) Position of the wiper

- When the wiper is in operation, it should not come in contact with the auxiliary thread take-up lever.
- When the needle stops in its upper stop position, a clearance of approximately 2 mm should be provided between the needle tip and the wiper.
- When the wiper is operated after the presser foot has been raised by operating the presser bar lifting lever, it should not come in contact with the presser foot.
- When the presser foot is raised as high as 10 mm by operating the knee-lifter, the wiper should not come in contact with the presser foot. (If the wiper comes in light contact with the presser foot, no problem will result.)

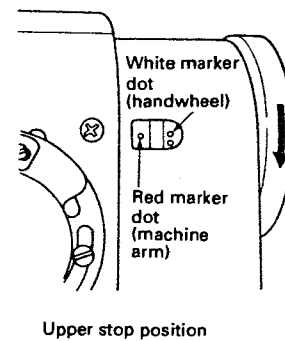
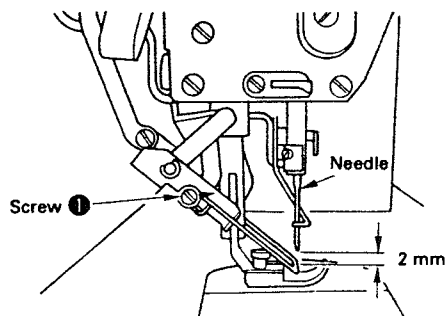
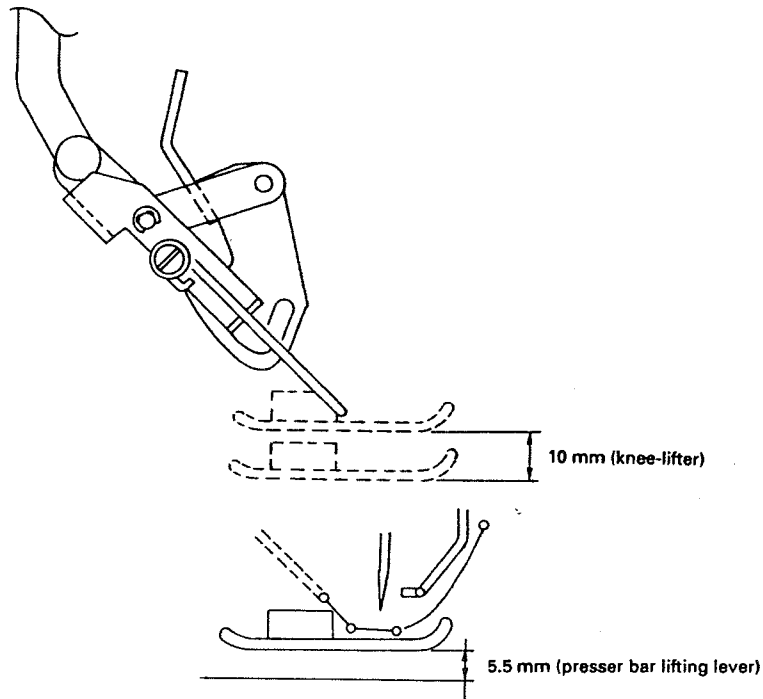

HOW TO ADJUST	RESULT OF IMPROPER ADJUSTMENT
<p>o Loosen screws ① (one each for both sides) and adjust the position of the wiper. Carefully tighten the screws while preventing the wiper from twisting.</p>	

STANDARD ADJUSTMENT

(46) Installing the presser foot and adjusting it

- Adjust the micro-lifting mechanism so that only the foot section of the presser foot moves during the vertical motion of the feed mechanism.

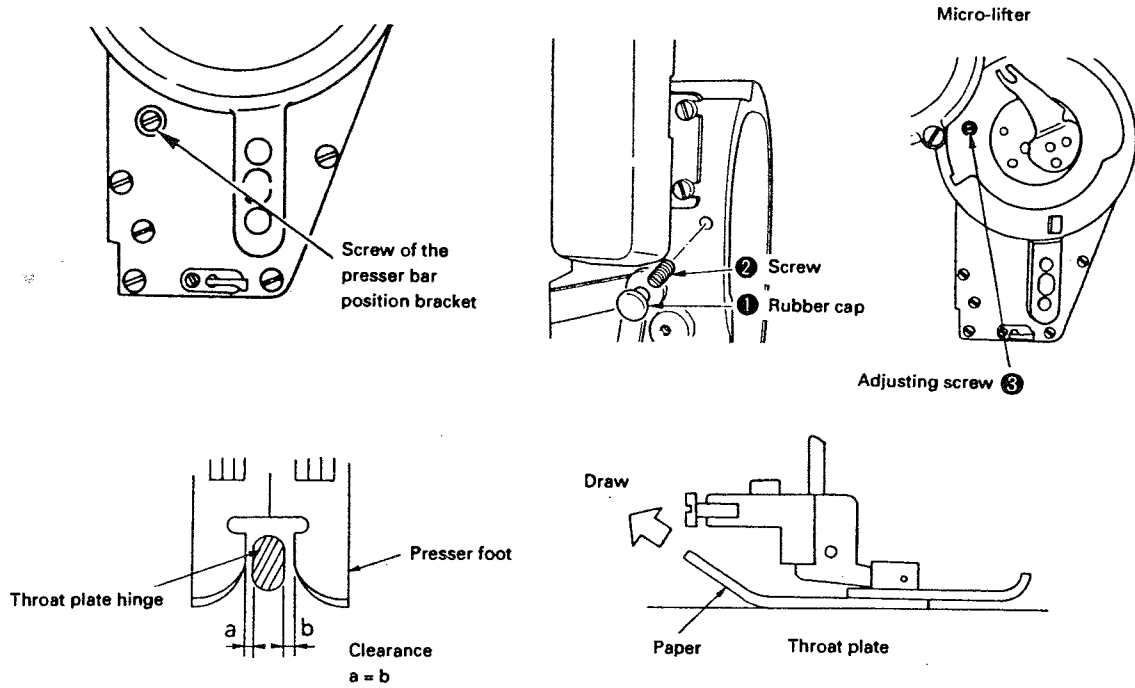

(47) Adjusting the slippage of the right- and left-hand side materials

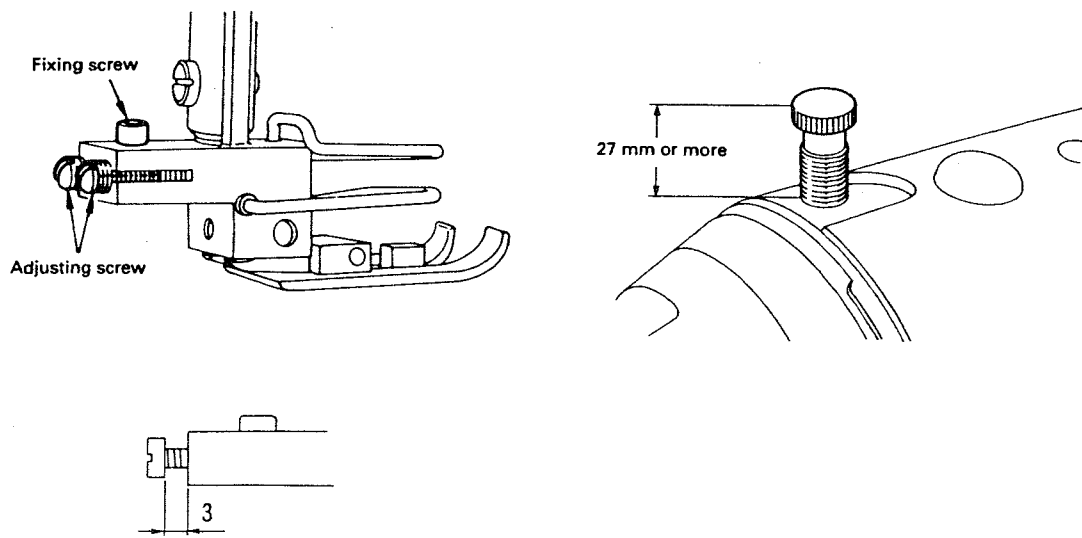

HOW TO ADJUST	RESULT OF IMPROPER ADJUSTMENT
<ol style="list-style-type: none"> 1. Remove the needle. 2. Lower the feed dog until it descends below the throat plate. Now, attach the presser foot so that the sole of the presser foot is closely fitted onto the top surface of the throat plate. 3. Loosen the screw in the presser bar position bracket. Adjust so that equal clearances a and b provided between the throat plate hinge and the presser foot and the presser foot is raised as high as 5.5 mm by operating the presser bar lifting lever. 4. Put a sheet of paper between the presser foot and the throat plate. 5. Remove rubber cap ❶ and loosen screw ❷. Then, tighten adjusting screw ❸ of the micro-lifting mechanism in the direction of the arrow until the presser foot is slightly raised to allow the paper to be lightly drawn out. Now, fix the micro-lifting mechanism by tightening the screw. 	<ul style="list-style-type: none"> ○ If the micro-lifting mechanism is not used, the presser foot will jump causing stitch length to be decreased when the sewing machine runs at high speed.
<ol style="list-style-type: none"> 1. Loosen the fixing screw, and adjust the slippage of the right- and left-hand side materials by tightening or loosening the adjusting screw. For example, if the right- and left-hand side materials are sewn as illustrated in the figure, adjust to obtain well-balanced feed of the materials by tightening the left-hand side screw to increase efficiency of feed for the left-hand side material or loosening the right-hand side screw to decrease efficiency of feed for the right-hand side material. The standard height of the adjusting screw is 3 mm as measured from the presser foot surface. Adjust the height of the adjusting screw using the aforementioned standard height for reference. <p>(Caution) For the LZ-2285, slippage between the right- and left-hand side materials cannot be adjusted if the presser foot pressure is too high. The standard height of the top end of presser spring regulator is 27 mm (approx. 2.5 kg) as measured from the bearing surface. If the presser spring regulator needs to be adjusted in accordance with the type of material to be used, do not adjust the presser spring regulator to a height that lower than 27 mm.</p>	

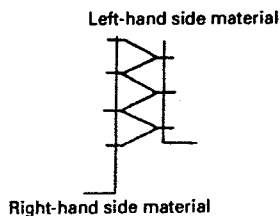

STANDARD ADJUSTMENT

(48) Feed timing for the LZ-2285

- Vertical direction: When the feed timing is aligned with timing mark D, the eccentric part of the hook driving shaft should be brought to the highest position.

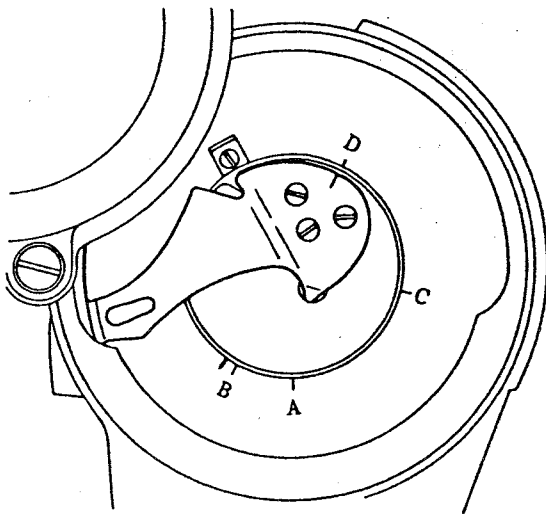

Eccentric section of the hook driving shaft

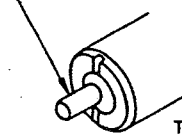

The eccentric section rests in the highest position.

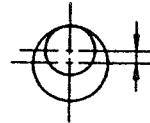

- Longitudinal direction: When the feed timing is adjusted to timing mark E, the marker line engraved on the feed cam should be aligned with the center of cam roller shaft.

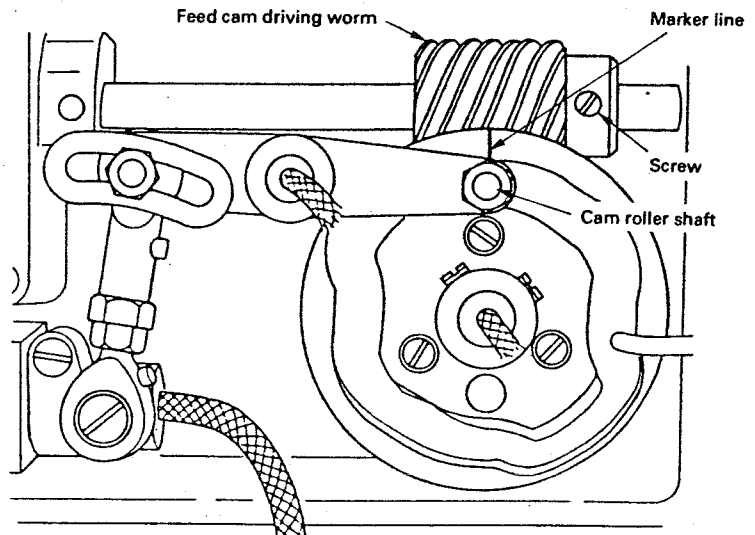
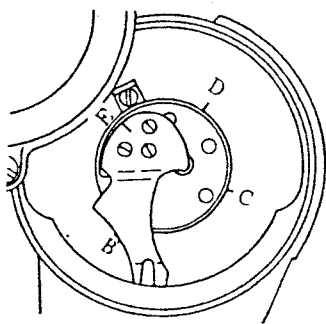

3. MOTOR PULLEY AND BELT

(1) Motor, motor pulley and belt for the sewing machine without a thread trimmer are as described below.

1) Use a clutch motor with an output of 400 W (2P).

2) Use the M type V belt.

3) Relation among the motor pulley, belt length and sewing speed of the sewing machine is as shown in the table below.

Outside diameter of motor pulley (mm)	Part No. of motor pulley	Sewing speed (s.p.m.)		Belt length	Part No. of belt
		50 Hz	60 Hz		
135 (mm)	MTKP0130000	5480	—	46 inches	MTJVM00460A
130	MTKP0125000	5270	—		
125	MTKP0120000	5060	—	45 inches	MTJVM00450A
120	MTKP0115000	4850	—		
115	MTKP0110000	4630	—		
110	MTKP0105000	4440	5330	44 inches	MTJVM00440A
105	MTKP0100000	4250	5040		
100	MTKP0950000	4000	4780		
95	MTKP0900000	3820	4540		
90	MTKP0850000	3610	4320	43 inches	MTJVM00430A
85	MTKP0800000	3390	4000		
80	MTKP0750000	3160	3790		
75	MTKP0700000	2950	3520		
70	MTKP0650000	2740	3260		
65	MTKP0600000	2530	3020	42 inches	MTJVM00420A
60	MTKP0550000	2320	2760		

★ Effective diameter of the motor pulley is obtained by subtracting 5 mm from the outside diameter.

★ Direction of rotation of the motor is counterclockwise as observed from the pulley. Take care not to allow the pulley to turn in the reverse direction.

(Caution)

If a commercially-available motor or JUKI's electronic-stop motor to enable the sewing machine without a thread trimmer to stop at a constant position, the belt may heavily vibrate.

In this case, use the JUKI's exclusive HM type belt which has been improved in terms of rigidity.

	Part No. of belt
46 inches	MTJVH00460A
45 inches	MTJVH00450A
44 inches	MTJVH00440A
43 inches	MTJVH00430A
42 inches	MTJVH00420A

(2) Use the HM type 42" belt (MTJVH00420A) for the sewing machine with a thread trimmer.

4. ADDITIONAL MACHINING TO THE COMMERCIALLY-AVAILABLE FEED MECHANISM

- (1) If a commercially-available feed mechanism is used with the LZ-2280-7 or -2286-7, the feed mechanism should be additionally machine to make a recess so as to prevent it from coming in contact with the moving knife. Machine the feed mechanism referring to the dimensions shown in the figure below.

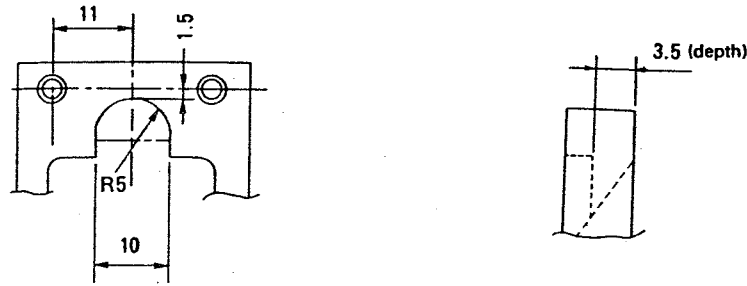

5. HOW TO WIND A BOBBIN

- (1) If decorative thread is used as bobbin thread, a bobbin may not be easily wound with the thread since the thread is likely to come off the bobbin winder tension controller of the bobbin winder. In this case, wind a bobbin while applying a low tension to the thread.

This will wind the bobbin smoothly.

To apply a tension to the thread, take one of the following methods.

- ① Wind the thread with a piece of net.
- ② Put a commercially-available binder clip, as illustrated below, at the side of the thread guide of the thread stand or the thread spool rest disk, and turn the thread once around the wire section of binder clip. Then pass the thread through the bobbin winder tension controller.

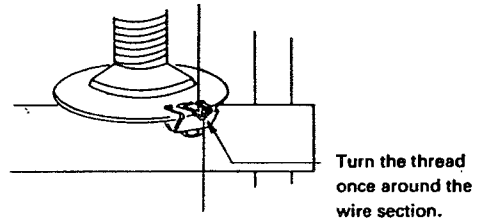
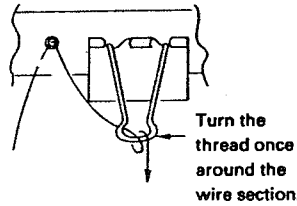
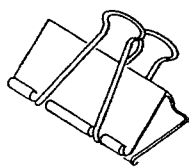

- ③ Turn the thread three times around the thread spool rest rod before passing it through the bobbin winder tension controller.

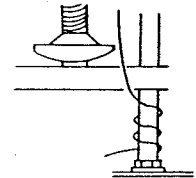

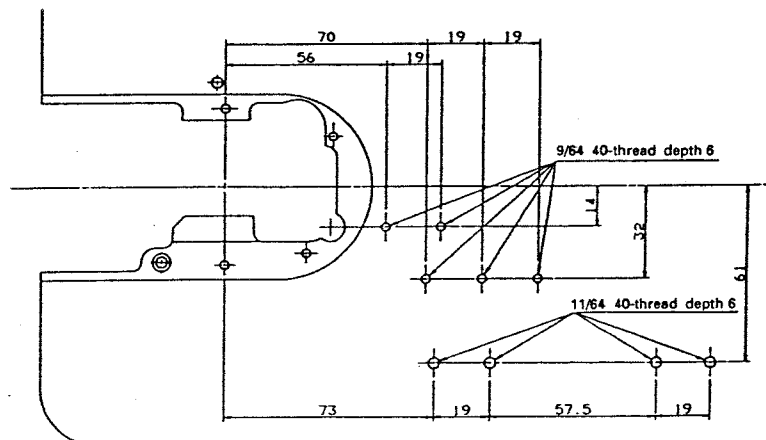
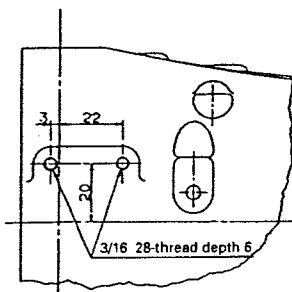

6. SCREWS FOR ATTACHMENTS

The machine arm and bed are provided with screws that can be used for installing attachments for the sewing machine. The locations and sizes of the screws are as shown below.



7. TROUBLES AND CORRECTIVE MEASURES (WITH REGARD TO SEWING)

Trouble	Description	Cause 1	Cause 2	Corrective measure and adjusting procedure
1. Thread breakage	1-1) Stitches are not properly formed. (Lower cloth)  Thread knots are made.	Smaller thread loops are produced.	Stroke of the thread take-up spring is too large.	Reduce the stroke of the thread take-up spring.
		Thread breakage occurs when the needle throws to the right.	The hook timing is excessively advanced.	Re-adjust the hook timing properly using a timing gauge.
		Larger thread loops are produced and they tilt.	The auxiliary thread take-up lever excessively works.	Lower the auxiliary thread take-up lever.
		Thread breakage occurs when the needle throws to the left.	Both the needle thread tension and bobbin thread tension are too high.	Reduce the tension to balance the needle thread and bobbin thread.
			Height of the needle bar is defective.	Properly adjust the height of the needle bar using a timing gauge.
			Stroke of the thread take-up spring is too small.	Lengthen the stroke of the thread take-up spring.
			The hook timing is excessively retarded.	Re-adjust the hook timing properly using a timing gauge.
			The auxiliary thread take-up lever fails to work.	Properly adjust the auxiliary thread take-up lever.
			Both the needle thread tension and bobbin thread tension are too low.	Increase the needle tension to balance the needle thread tension and bobbin thread tension.
			Height of the needle bar is defective.	Properly adjust the height of the needle bar using a timing gauge.
		An excessive clearance is provided between the blade point of the hook and the needle.	If the needle guard works excessively, raise the needle guard.	Adjust the needle-to-hook relation again.
		The material flops.	Needle slot in the throat plate is too large.	Replace the throat plate with another throat plate which has a smaller needle slot.
			The sole of the presser foot is not closely fitted onto the throat plate surface.	Loosen the screw in the presser foot, and re-tighten it with the presser foot closely fitted onto the throat plate.
			The recess on the sole of the presser foot is too large.	Replace the presser foot with another one which has a smaller recess.
			The needle sticks in fabric yarn and the thread is retained by the fabric yarn. (Particularly when power net is sewn with span thread)	Use a needle which has a round tip. We recommend the 438SKL needle.
			The needle has a blunt tip.	Replace the needle with a new one.
		Blade point of the hook is defective.		Correct the blade point of the hook or replace the hook with a new one.

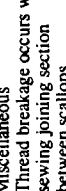
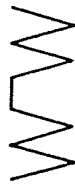
Trouble	Description	Cause 1	Cause 2	Corrective measure and adjusting procedure
1-2) The thread breaks when the needle reaches the lowest position of its stroke.	 <p>(Lower cloth)</p>	The time when the needle and bobbin threads go over the hook is too late. As a result, the threads break under the hook.	<p>The needle thread tension is too low.</p> <p>The stroke of the thread take-up spring is too small.</p> <p>The tension of the thread take-up spring is too low.</p> <p>The tension provided by the pre-tension disk is too low.</p> <p>The bobbin case holder stopper is positioned too near to the needle.</p>	<p>Increase the needle thread tension. Then balance the tension of needle and bobbin threads.</p> <p>Lengthen the stroke of the thread take-up spring.</p> <p>Increase the tension of the thread take-up spring.</p> <p>Increase the tension provided by the pre-tension disk.</p> <p>Adjust the position of the bobbin case stopper by moving it away from the needle.</p>
1-3) Miscellaneous Thread breakage occurs when sewing joining section between scallops.		The sewing machine fails to perform sewing with consistency because of excessively low thread tension.		Set the thread tension at a higher value. (For reference, 65 g for the needle thread and 25 g for the bobbin thread)
2. Stitch skipping		Same causes as "1-1) Stitches are not properly formed."		
3. Isolated idling loops		Presser foot components are defective.	<p>The needle slot in the presser foot is located this side of the needle slot in the throat plate.</p> <p>The presser foot rises.</p> <p>Recess on the sole of the presser foot is smaller for the stitch length employed.</p> <p>The needle thread tension is insufficient.</p> <p>The thread take-up spring has been improperly adjusted.</p> <p>The bobbin case holder stopper is defective</p>	<p>Replace the presser foot with a new one, or correct the presser bar.</p> <p>Return the micro-lifting mechanism to the home position, or re-adjust the position of the presser bar position bracket.</p> <p>Replace the presser foot with a new one.</p> <p>Increase the needle thread tension.</p> <p>Maximize the distance between the bobbin case and the hook as long as the bobbin case does not rotate.</p>

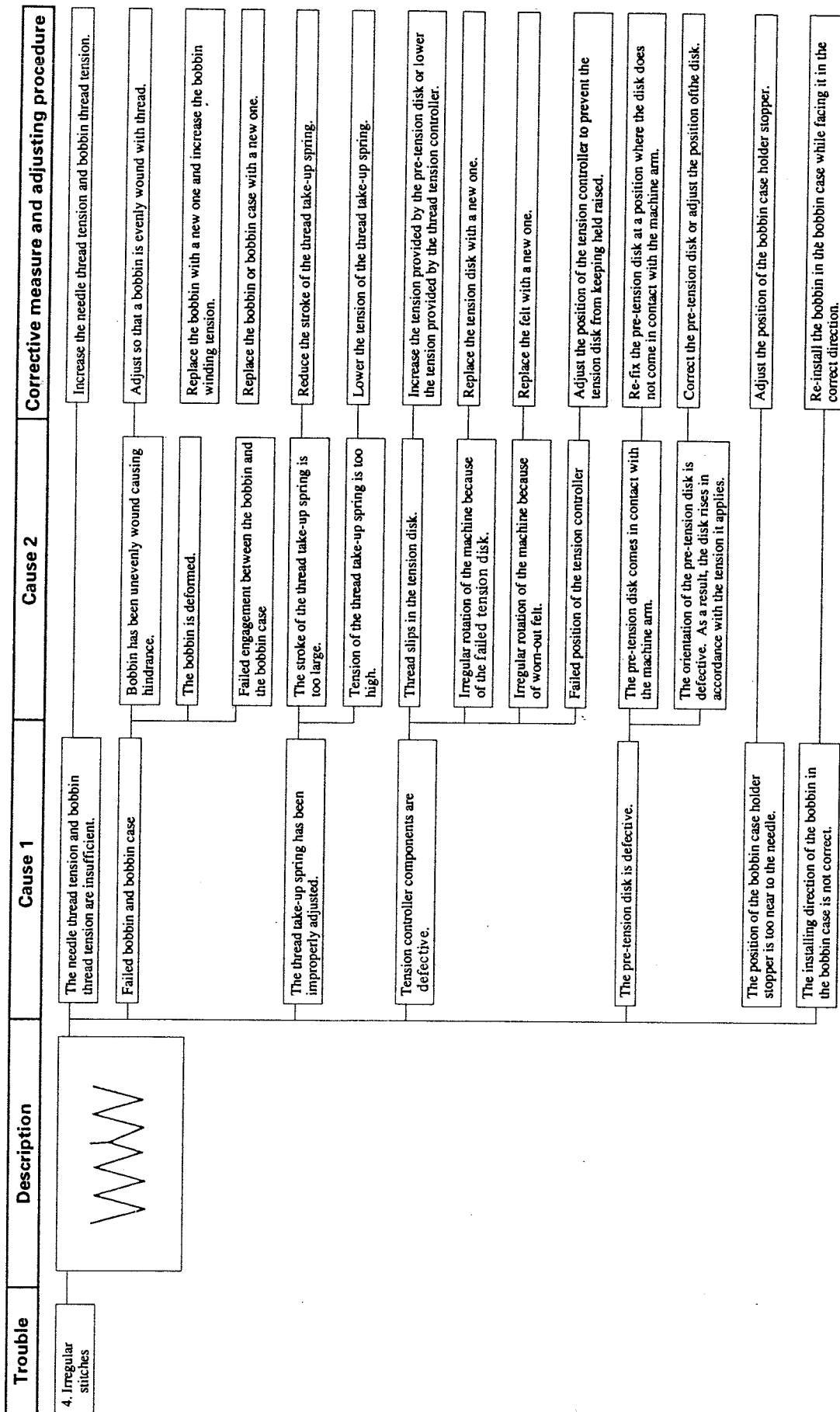

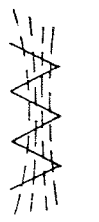
Trouble	Description	Cause 1	Cause 2	Corrective measure and adjusting procedure
5. Material swells at the sewn part.	Stitches gather at the center of the material. 	<ul style="list-style-type: none"> The needle thread tension and bobbin thread tension are too high. The presser foot is defective. The material flops. 	<ul style="list-style-type: none"> Thread path has been poorly finished. Feed timing is excessively advanced. The presser foot pressure is too low. Failed parallelism of the presser foot Needle slot in the throat plate is too large. The recess on the sole of the presser foot is too large. The needle has a blunt tip. 	<ul style="list-style-type: none"> Finish the thread path to smoothen its surface. Adjust the feed timing to the proper one. Increase the presser foot pressure. Re-attach the presser foot so that it closely fitted onto the throat plate, or replace the presser foot with a new one. Replace the throat plate with another throat plate which has a smaller needle slot in accordance with the needle used and the zigzag width specified. Replace the presser foot with another one which has a smaller recess or no recess. Replace the needle with a new one.
6. Uneven material feed	The upper cloth and lower cloth shift in the feeding direction.	<ul style="list-style-type: none"> The presser foot is defective. The feed mechanism is defective. 	<ul style="list-style-type: none"> Presser foot pressure is too high. The sole of the presser foot has been poorly finished. Failed inclination of the feed dog Height of the feed dog is excessive. 	<ul style="list-style-type: none"> Lower the presser foot pressure. If an aluminum presser bar, that is optionally available, is used, only the presser foot pressure can be lowered without reducing efficiency of feed. Buff up the sole of the presser foot to enable the material to be smoothly fed under the presser foot. Adjust the inclination of the feed dog to the standard state (where the feed dog is positioned with its front side lowered.) Adjust the height of the feed dog to the standard height (0.8 mm) or slightly lower the feed dog below the standard height.

8. TROUBLES AND CORRECTIVE MEASURE (WITH REGARD TO MECHANICAL COMPONENTS)

Trouble	Cause 1	Cause 2	Corrective measure and adjusting procedure
1. Several stitches skip or thread comes off at the start of sewing.	1-1) Length of thread remaining after thread trimming is too short.	1)-A Tension provided by the pre-tension disk is too high.	Loosen the pre-tension disk as long as the thread slips in the tension disk.
		1)-B The tension disk fails to rise at the time of thread trimming.	Inspect the thread tension releasing solenoid components and adjust them, if necessary.
		1)-C The tension disk comes in contact with the thread take-up spring guard.	Correct the position of the tension disk and thread take-up spring guard so that they do not come in contact with each other.
		1)-D The counter knife is positioned too near to the needle.	Remove the knife unit and adjust the position of the counter knife.
		1)-E The cam timing is excessively advanced.	Properly adjust the cam timing.
	1-2) Needle thread feeding amount is insufficient.	2)-A Stroke of the thread feeding wire is too small.	Lengthen the stroke of the thread feeding wire.
		2)-B The thread feeding wire has been improperly positioned.	Properly adjust the position of the thread feeding wire.
1-3) Thread trimming failure because the bobbin thread is too short.	2)-C The thread slips off the thread feeding wire and take-up thread guide.	Re-thread the thread feeding wire and take-up thread guide. If the thread frequently slips off the thread feeding wire, replace the wire with a new one.	
1-4) Failed clamp of the bobbin thread	3)-A Refer to "1-1)-D."		
1-5) The needle thread and bobbin thread do not neatly interlace with each other at the start of sewing.	4)-A		
1-6) Length of the needle thread remaining at the needle eyelet after thread trimming is not uniform.	5)-A Sewing speed at the start of sewing is too high.		
1-7) Idle stitches are made at the start of sewing.	6)-A The thread is rubbed by the counter knife before the moving knife engages with the counter knife, resulting in thread breakage.		
	7)-A The needle thread and bobbin thread do not interlace with each other because the material makes no resistance to the threads.		
			This prevents the needle thread and bobbin thread from smoothly interlacing with each other.
			Re-sharpen the counter knife blade or replace the counter knife with a new one.
			Place the threads under the presser foot and start the sewing machine while holding the threads there.

Trouble	Cause 1	Cause 2	Corrective measure and adjusting procedure
2. Needle thread end rests on the material at the start of sewing.	<p>2-1) Length of thread remaining at the needle eyelet is excessive.</p> <p>2-2) Top end of tangled-up thread on the wrong side of the material appears on the right side of the material.</p>	<p>1)-A Tension applied by the pre-tension disk is too low.</p> <p>1)-B Thread trimming cam timing has been excessively retarded.</p> <p>1)-C The counter knife is positioned too far from the needle.</p>	<p>Increase the tension applied by the pre-tension disk.</p> <p>Adjust the thread trimming cam timing to the correct value.</p> <p>Remove the knife unit and adjust the position of the counter knife.</p> <p>Place the needle thread under the presser foot at the start of sewing, thereby preventing the thread from being tangled up. (Particularly when reverse feed stitches are made at the start of sewing)</p>
3. Thread slips off the needle eyelet immediately after thread trimming.	<p>3-1) The moving knife fails to separate the threads and trims the thread at the needle.</p>	<p>1)-A Thread trimming cam timing has been excessively advanced.</p> <p>1)-B Locus of the moving knife is defective.</p>	<p>Properly adjust the thread trimming cam timing.</p> <p>Re-install the knife unit or replace the knife unit with a new one.</p>
4. Thread breaks at the start of sewing.	<p>4-1) The needle thread feeding amount at the time of thread trimming is excessive, causing the thread to break when the needle reaches the lowest position of its stroke at the start of sewing.</p> <p>4-2) Stitch length is too short.</p>	<p>2)-A The thread slacks because of small stitch length.</p> <p>2)-B The needle repeatedly enters the same point since the stitch length is small.</p> <p>2)-C Thread tension fluctuates because of tangled-up thread.</p>	<p>Reduce the needle thread feeding amount.</p> <p>To start sewing with a small stitch length, place the needle thread end under the presser foot and start the sewing machine.</p>

Trouble	Cause 1	Cause 2	Corrective measure and adjusting procedure
5. Needle breakage	5-1) The needle breaks when it hits against this side of the needle slot in the throat plate.	1)-A Needle thread tension is too high.	Reduce the needle thread tension. The needle thread tension may have been increased because of isolated idling loops. So, also refer to the description of "Isolated idling loops."
	5-2) The needle breaks when it hits against both sides of the needle slot in the throat plate.	1)-B The needle fails to enter the needle slot in the throat plate.	Adjust the needle entry point.
		2)-A Zigzag width is wider than the needle slot.	Decrease the zigzag width or replace the throat plate with an appropriate one.
		2)-B The needle throwing range exceeds the needle slot since the needle throw positioning lever has been moved too far.	Return the needle throw positioning lever to the home position and make the stopper work at a position where the needle does not come in contact with the throat plate.
6. Needle thread cannot be cut.	6-1) The last stitch skips.	1)-A Refer to the description of "Stitch skipping."	
		1)-B Thread tension is insufficient at the time of thread trimming.	Increase the thread tension provided by the pre-tension disk. (6 g or higher)
	6-2) The moving knife spreads the thread loops.	2)-A Thread tension is insufficient at the time of thread trimming.	Increase the thread tension provided by the pre-tension disk.
			Lengthen the stroke of the needle thread feeding device. (The needle thread is tensed by steeply bending the thread path.)
7. Bobbin thread cannot be cut.	7-1) The moving knife spreads the bobbin thread.	1)-A Bobbin thread tension is too low.	Increase the bobbin thread tension, then balance the needle thread and bobbin thread.

9. DRAWING OF THE TABLE

(1) For the sewing machine without a thread trimmer

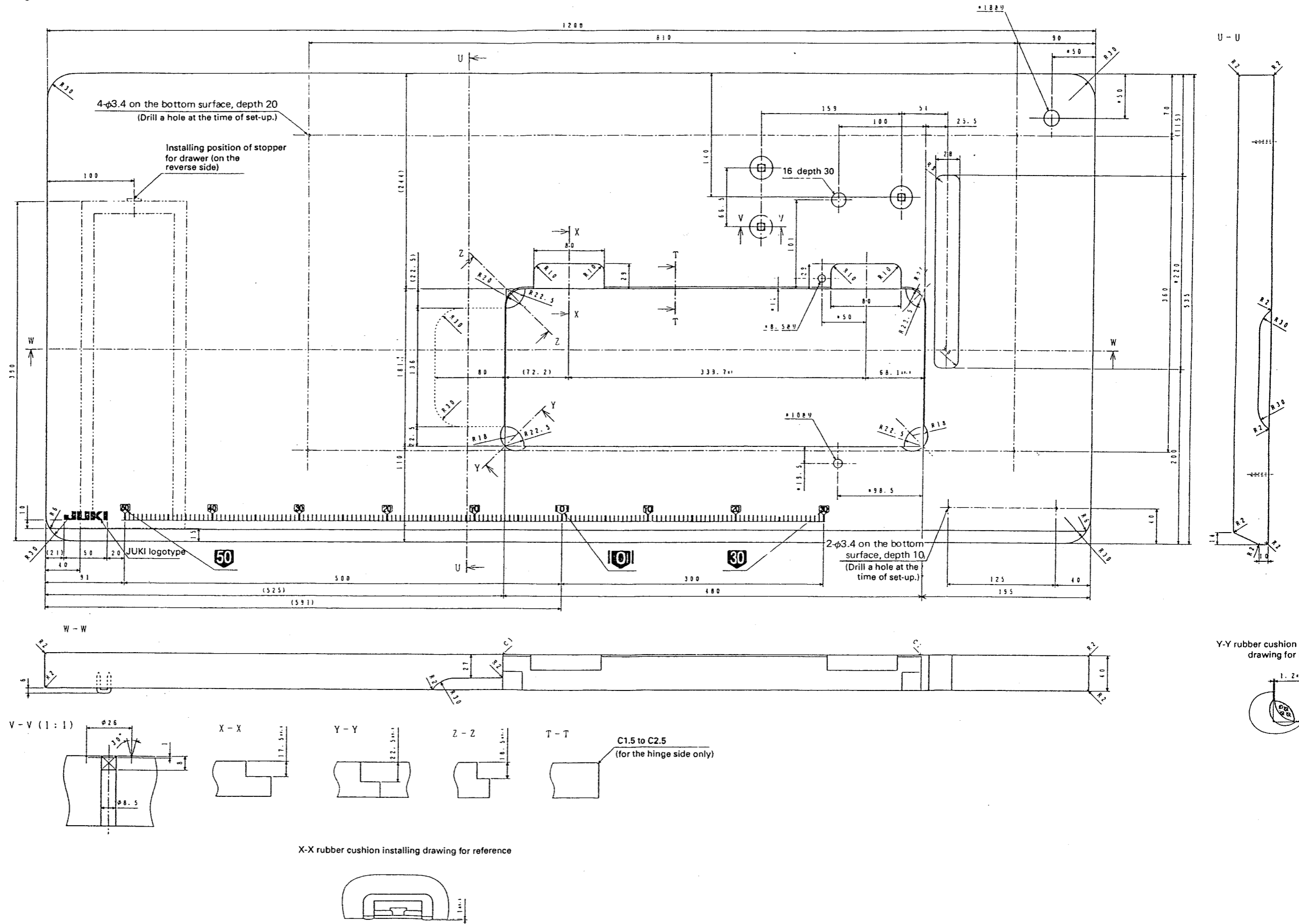

(2) For the sewing machine with a thread trimmer

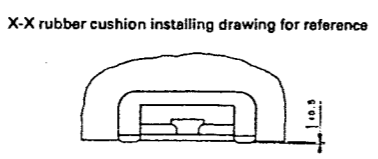
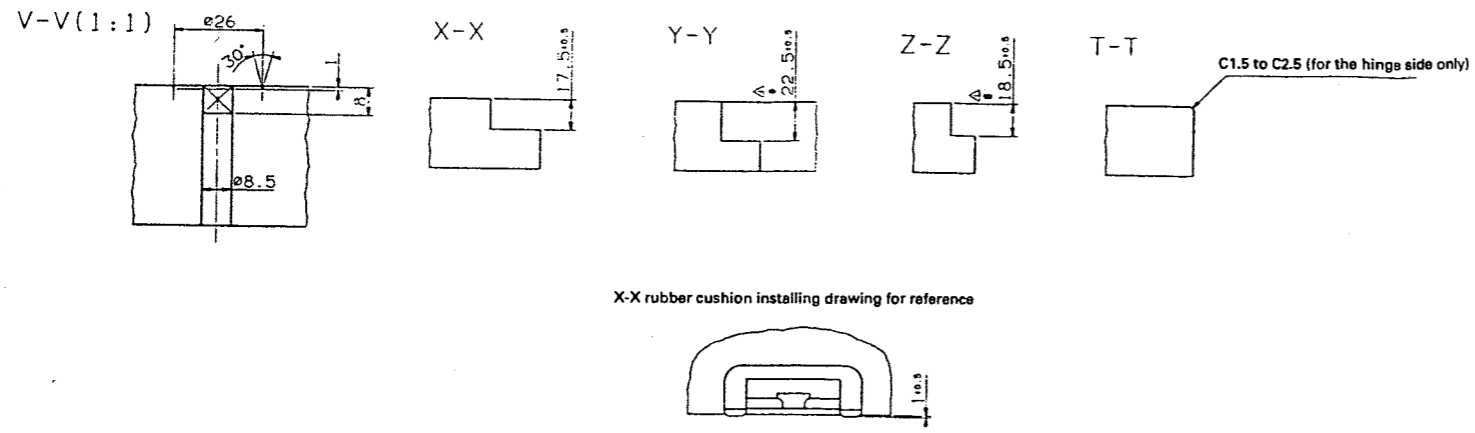
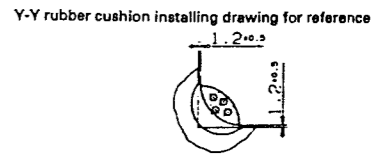
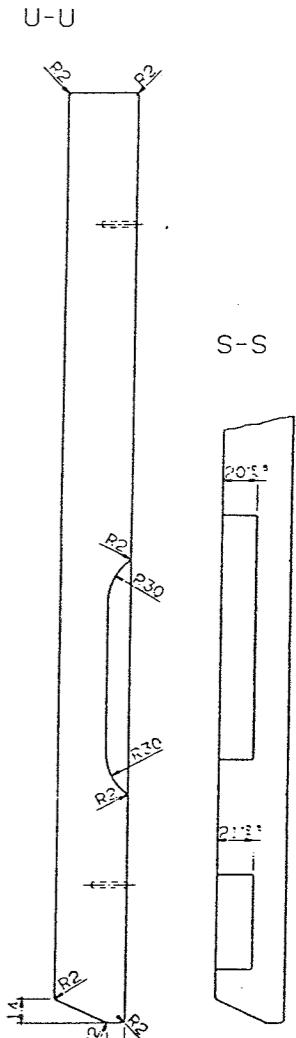
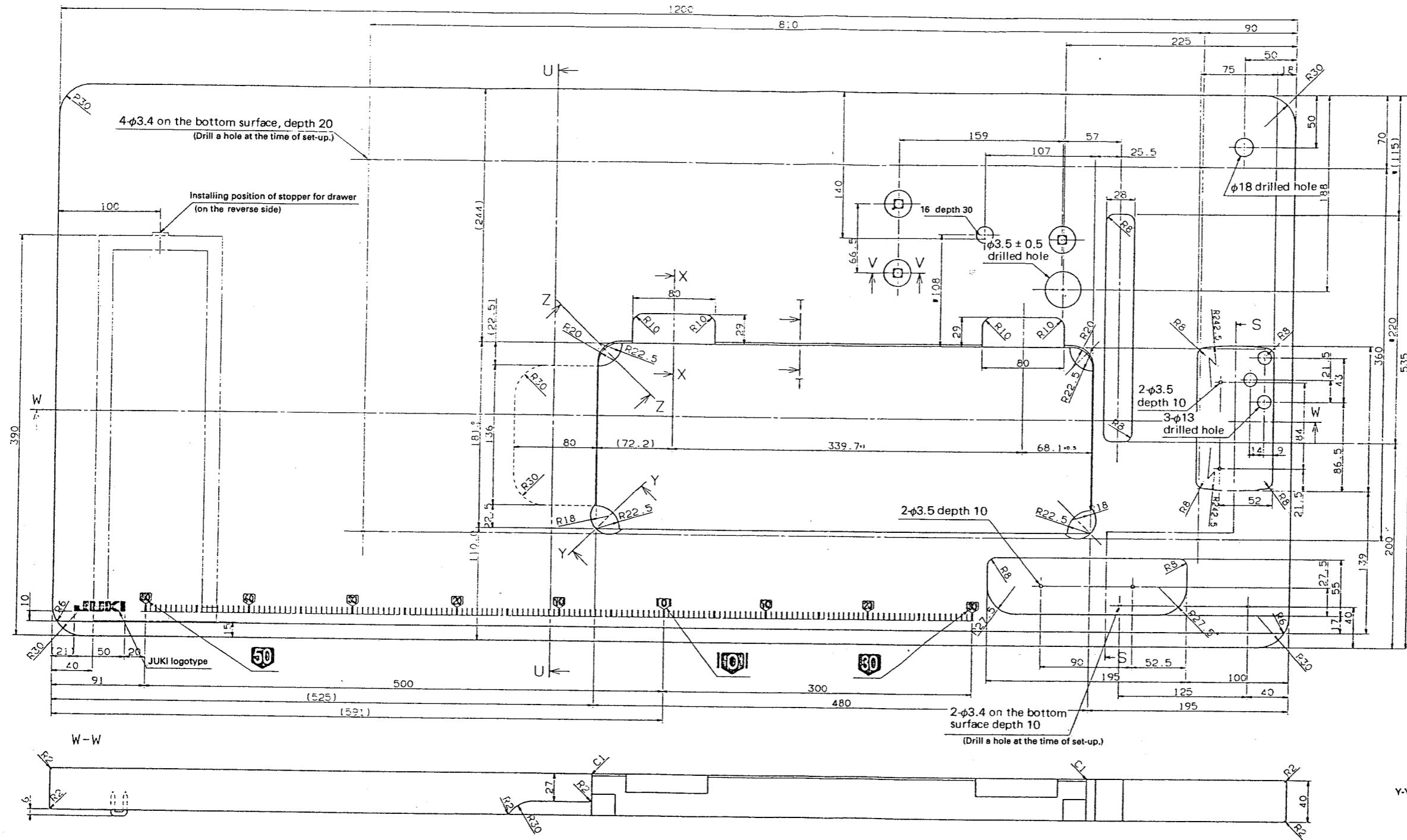

JUKI®

JUKI CORPORATION

INTERNATIONAL SALES H.Q.
8-2-1, KOKURYO-CHO, CHOFU-SHI
TOKYO 182-8655, JAPAN
PHONE : (81)3-3430-4001 to 4005
FAX : (81)3-3430-4909 . 4914 . 4984
TELEX : J22967

Copyright © 1998-2002 JUKI CORP.
本書の内容を無断で転載、複写することを
禁止します。
All rights reserved throughout the world.

JUKI 株式会社

〒182-8655 東京都調布市国領町8-2-1
TEL. 03-3480-1111(代表)

営業本部
TEL. 03-3430-4001(ダイヤルイン)

お買い求め、ご相談は
To order or for further
information,
please contact :

※このパーツリストは商品改良のため予告なく変更する事があります。
* The description covered in this parts list is subject to change for improvement of the commodity without notice.
※このパーツリストは、2002年7月 現在の商品仕様で編集したものです。
* This parts list is edited in accordance with the product specifications as of July 2002.