

5. MEMORY SWITCH









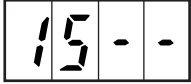

- Purpose of the memory switch

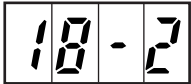
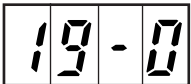
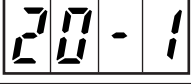
The memory switches are able to set the various performances of the sewing machine by means of programming.

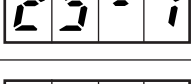
The contents are separated in the user level (U) and the service level (S).

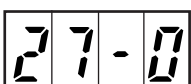
Note : The contents of the memory switches may vary in accordance with the revision of SYSTEM ROM. (The following contents are in case of "005".)

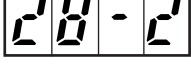
Display	Function	Setting range	State at the time of delivery	Remarks
01--	Setting of the max. sewing speed limitation (in a unit of 100 rpm)	200 to 2,200 r.p.m.	2,200 rpm	
02--	Start-up speed of 1st to 5th stitch at sewing start is set in unit of 100 r.p.m.	1st stitch : 200 to 900 2nd stitch : 200 to 2,200 3rd stitch : 200 to 2,200 4th stitch : 200 to 2,200 5th stitch : 200 to 2,200	200 rpm 600 rpm 1,000 rpm 2,200 rpm 2,200 rpm	
03--	This function sets whether or not the calling of the service pattern data is acceptable.	Pattern Nos. 1 to 64 can be individually set. 0 : Calling not possible 1 : Calling possible	51 : 1 52 : 1 53 : 1 54 : 1 60 : 1	Nos. 1 to 30 mount bar tacking patterns of LK-1900.
04-0	Display of change of pattern No., X/Y scale, max. speed limitation, and heat cutter temperature and whether or not to change these items can be set. (Prevention of maloperation)	0 : OFF 1 : ON (key-lock)	0	
05-0	Setting of the counter operation Production counter : Adding counter Bobbin thread counter : Subtracting counter	0 : Addition 1 : Subtraction	0	
06-0	Needle bar stop position is set. After up-position stop, needle bar rotates reversely and stops in case of needle up stop mode. (The needle top position is high at the time of stop.)	0 : Up-position stop (H and G types : 53°) (Z type : 40°) 1 : Needle up stop (22°)	0	
07-0	This function sets the base point of enlargement/reduction.	0 : Origin 1 : 2nd origin (sewing start point)	0	
08-0	Whether to execute origin retrieval after completion of sewing is selected. (When sewing with normal pattern No., or P1 to P7)	0 : Ineffective 1 : Effective	0	
09-0	Whether to execute origin retrieval after completion of sewing is selected. (When sewing with combination pattern)	0 : Ineffective 1 : Effective	0	
10-0	This function selects the pedal specifications.	0 : Standard 1-pedal 1 : 2-step pedal 2 : 1-pedal (PK-57) 3 : 3-step pedal (priority to the right) 4 : 3-step pedal (priority to the left) 5 : 3-step pedal (no priority)	0	
11-1	Whether to output wiper is selected.	0 : Ineffective 1 : Effective	1	
13-0	State of feeding frame after completion of sewing (lifting or lowering) is selected.	0 : Lifting 1 : Kept lowered	0	
14--	Confirmation of contents of total counter (8 digits) (Latter 4 digits and former 4 digits are separately displayed.)	+ / Forward : Upper digits are displayed. - / Backward : Lower digits are displayed.	0 (At the time of assembling)	

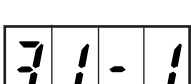
Display	Function	Setting range	State at the time of delivery	Remarks
	Travel limit of X-feed or Y-feed is set. (Setting separated in domains of +X, -X, +Y and -Y is possible.)	X : 0 to ± 50 X : 0 to ± 30 (unit : 1 mm)	+X : 50 -X : 50 +X : 30 -X : 30	
	Input of temporary stop switch is selected. (When selecting panel reset, input of temporary stop is performed only during sewing operation.)	0 : Ineffective 1 : Panel reset key 2 : Switch on the machine head	2	
	Feed timing is selected. When thread is not well-tightened, set 1 or 0 to increase effect.	0 : 161° Slow ↑ 1 : 149° 2 : 137° 3 : 125° Fast ↓	2	Start of feeding is set by the angle of main shaft.
	Selection of control of simultaneous jump feed with thread trimming	0 : Yes 1 : Not defined 2 : Not defined 3 : No	H, G : 3 Z : 0	Control starts when "1" or "2" is set.
	Effective/ineffective of needle thread breakage detection function is selected. (Detected at 8 stitches at sewing start and 3 stitches in midway)	0 : No 1 : Yes 2 : Not adjusted	1	Do not use setting "2".
	Selection of effective/ineffective of intermediate presser control	0 : No 1 : Yes	0	LK-1942 only
	Wiper sweeping position is set.	0 : Wiper sweeps above the intermediate presser. 1 : Wiper sweeps below the intermediate presser.	0	LK-1942 only
	Whether to perform air pressure detection is selected.	0 : Ineffective 1 : Effective	1	
	Origin is corrected when using presser of AMS-206.	0 : No correction 1 : Correction is performed.	0	Automatic shift of Y = -12 mm immediately after origin retrieval
	This function selects the basting mode. Pattern sewing data is read to "jump feed" and curved point to "sewing" respectively and the function is actuated.	0 : Normal 1 : Basting	0	Optional tension disk floating solenoid is required at the time of basting. (Memory switch No. 28-1 setting ; H type only)
	Tension disk No. 2 floating function (H type optional), or thread draw-out function (G and Z types) is selected.	0 : Ineffective 1 : Disk floating 2 : Thread draw-out	2	In either function, connect to P59 on MAIN circuit board. (Simultaneous use is not possible.)
	Effective/ineffective of execution of automatic preparation action after turning ON the power is selected.	0 : Ineffective 1 : Effective	0	
	This function controls thread tension controller No. 3 and inverting clamp using the inverting pattern.	0 : When using the inverting clamp device 1 : When using the thread tension controller No. 3 2 : When using both thread tension controller No. 3 and inverting clamp device	1	
	Selection of needle bar up-position stop holding mode	0 : No 1 : Yes	0	

Note 1)

Note 2)







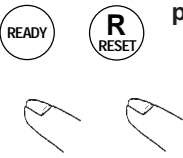
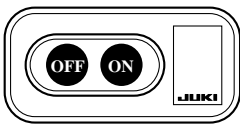

Note 3)

- Note) 1. If the feed timing is set to slow, danger of needle breakage may occur when the cloth is excessively thick. So, be careful.
2. When ineffective of intermediate presser control is selected, "lifting is fixed". Be sure to remove the intermediate presser since it comes in contact with needle bar.
In addition, the intermediate presser cam and roller may interfere with each other. Move the intermediate presser cam to the position where it does not interfere and fix it.
3. The presser with the inverting clamp is made to special order. For the details, refer to the respective items "Thread tension controller No. 3 and the inverting clamp device", "How to use the optional thread tension controller No. 3" and "Solenoid valve circuit diagram".



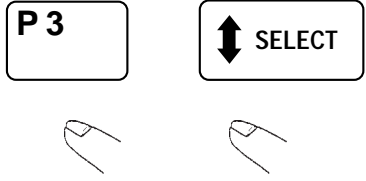

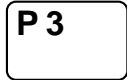





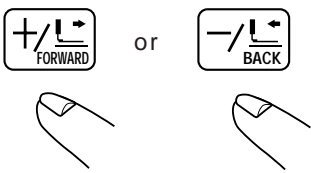
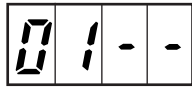

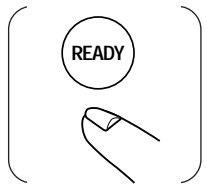
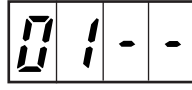

Display	Function	Setting range	State at the time of delivery	Remarks
	This function selects timing of presser lifting after completion of sewing.	0 : Presser goes up after thread trimming and return to origin. 1 : Presser goes up immediately after thread trimming.	0	When "1" is set, presser goes up immediately after thread trimming and the cloth can be immediately taken out.
	This function is not used with LK-1941/42. Do not change the setting.	—	0	
	Output of needle cooler is selected.	0 : Ineffective 1 : Effective	1	
	Effective/ineffective of control of thread trimming command of pattern data is selected.	0 : Effective 1 : Ineffective	0	It becomes effective at the time of temporary stop or the like even at the time of ineffective.
	Effective/ineffective of control of thread trimming device is selected.	0 : Effective 1 : Ineffective	0	When ineffective is set, thread trimming is not possible in any case.
	Setting of delay time of wiper ON after heat cutter OFF Timing from heat cutter output OFF to wiper ON is changed. Set the delay time longer especially when thick thread is used. (Possible to set in unit of 50ms)	0 to 200ms	100	For Z type only
	Effective/ineffective of control of optional thread clamp device is selected.	0 : Ineffective 1 : Effective	0	
	OFF timing of guide cylinder of optional thread clamp device is set by the number of stitches from the start of sewing.	2 to 5 stitches	2	
	Speed of revolution of bobbin winder is set.	0 : High speed (1,600 r.p.m.) 1 : Low speed (800 r.p.m.)	0	
	Wiper operating timing at the time of needle up-position stop (No. 6-1) is set.	0 : Needle-up stop position 1 : Upper position	0	
	Selection of returning route to the sewing start point When effective is set, the machine returns to the sewing start point taking the route tracing the sewing pattern reversely.	0 : Ineffective 1 : Effective	0	Set to effective when linear move is not possible due to the limitation of shape of presser or the like.
	Initialization of model specifications is executed.	41 : LK-1941ZA 42 : LK-1942H (G) A 43 : When LK-1941ZA is changed to the thread trimming with knife type 44 : When LK-1942H(G)A is changed to the hot wire thread trimming type	41	When setting is changed, all the contents of memory switch are initialized to the default values.

(1) Operating method

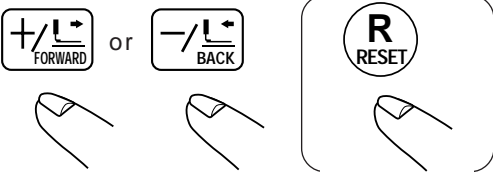
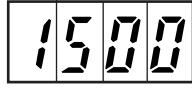









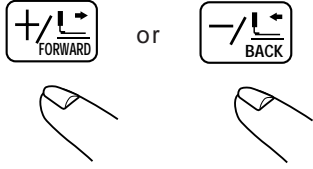
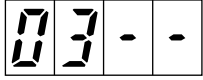



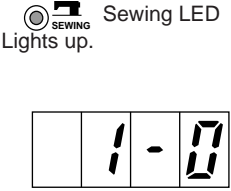

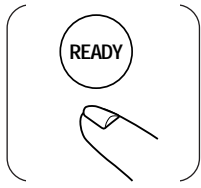
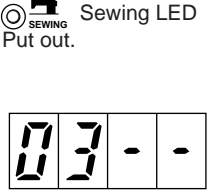
1) How to start the memory switches

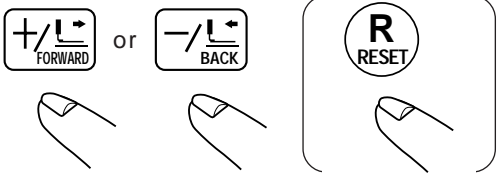
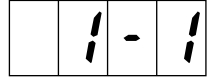
Step	Operation method	Indication	Explanation
1	<p>Keep pressing.</p>   <p>Turn ON the power switch.</p>		<p>Pressing  key and  key, turn ON the power switch. (Start of the user level)</p>
2			<p>Immediately after turning ON the power switch, simultaneously press  key and  key. (The level moves to the service level.)</p>



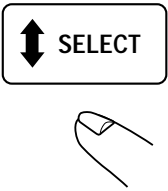
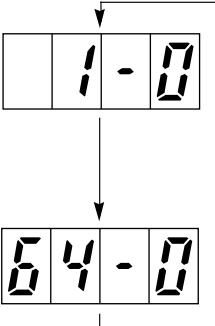

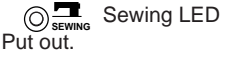





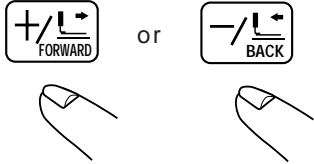
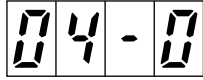

Operation when both the latter first digit and second digit on the indication are "--".

Step	Operation method	Indication	Explanation
-1		<p>[Ex.] When No. 01 is indicated.</p> 	<p>Press down  and  keys to select the indication No. desired to change.</p>
-2		<p> Sewing LED Lights up.</p> 	<p>Press down  key to light up the sewing LED.</p>
			<p>In step -2, if pressing down  key again, the indication returns to the indication No.</p>
-3		<p>[Ex.] When the max. speed limitation is 1,500 r.p.m.</p> 	<p>Press down  and  keys to change and check the contents. (The setting returns to the initial setting by pressing down  key.)</p>
-4		<p> Sewing LED Put out.</p>	<p>After setting, press down  key and put out the sewing LED. Then register the contents.</p>

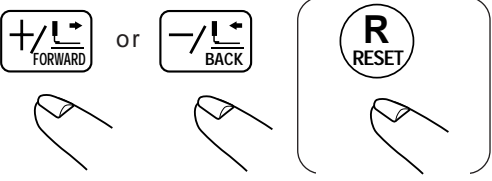
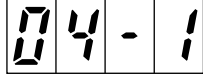



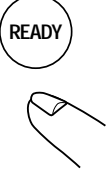





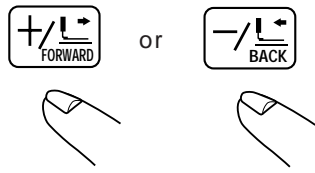



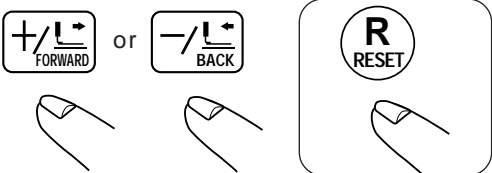

Operation when the indication is “03 --”.

Step	Operation method	Indication	Explanation
-1			<p>Press down  or  key to select the indication No. 3.</p>
-2			<p>Press down  key to light up Sewing LED.</p>
			<p>When the step is - 2, if  key is pressed twice, Sewing LED is put out and the indication returns to No. 03.</p>
-3		<p>[Ex.] Calling of the standard pattern data to pattern No. 1 is possible.</p> 	<p>Press down  or  key to change whether or not to call the standard pattern data. (The setting returns to the initial value by pressing down  key.)</p>
-4			<p>Every time  key is pressed, the pattern No. increases by one. (Pattern Nos. : 1 to 64) When the pattern No. is changed to the No. desired, change whether or not to call the standard pattern by operating the step - 3. After the pattern No. 64, the pattern No. returns to the Pattern No. 1.</p>
7			<p>After setting, press down  key to put out Sewing LED and register.</p>

Operation when the latter second digit is “-” and first digit is “Numeral”

Step	Operation method	Indication	Explanation
-1		<p>[Ex.] When the indication No. is No. 04.</p> 	<p>Press down  or  key to select the indication No. 04.</p>
-2		 Sewing LED Lights up.	<p>Press down  key to light up Sewing LED.</p>
-3			<p>Press down  or  key to change the set value. (The setting returns to the initial value by pressing down  key.)</p>
-4		 Sewing LED Put out.	<p>After setting, press down  key to put out Sewing LED and register.</p>

Operation when the indication section is “99.”

Step	Operation method	Indication	Explanation
-1		<p>[Ex.] When the indication No. is No. 99.</p> 	Press down  or  key to select the indication No. 99.
-2		 Sewing LED Lights up. 	Press down  key to light up Sewing LED.
-3			Press down  or  key to change the set value. (The setting returns to the initial value by pressing down  key.)
-4		 Sewing LED Put out.	After setting, press down  key to put out Sewing LED and register.

2) How to finish the memory switches

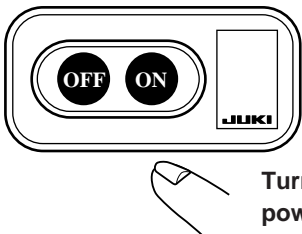
Step	Operation method	Indication	Explanation
1	 <p>Turn OFF the power switch.</p>		Turn OFF the power.