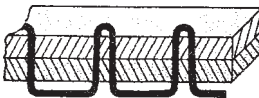
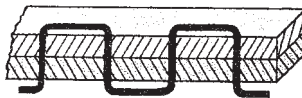

1. SPECIFICATIONS

No.	Item	Specifications			
		FLS-350N	FLS-350NA	FLS-350NB	FLS-351NA
1	Model	FLS-350N	FLS-350NA	FLS-350NB	FLS-351NA
2	Sewing speed	120 to 400 rpm (300 rpm or less for synthetic thread)	140 to 400 rpm (300 rpm or less for synthetic thread)	140 to 300 rpm	140 to 300 rpm (250 rpm or less for easing in of fullness)
3	Stitch length (Max. total length of top/bottom stitches)	0.6 mm to 8 mm (Up to 16 mm)			0.6 mm to 8 mm (Up to 16 mm) In case of easing in of fullness with synthetic thread : 0.6 mm to 3 mm (Up to 6 mm)
4	Reverse feed stitching	Actuated by push-button (Stitch length is fixed at 1 to 2 mm for both top / bottom stitches)			
5	Stitch specifications	1-needle, 1-thread, special stitching (handstitching type)			
6	Needle *	ORGAN DPN-1032B/38		ORGAN DPN-1032B/49	ORGAN DPN-1032B/32
7	Thread (Thread recommended by JUKI)	FUJIX Co. KING handstitching machine thread (for light-weight materials) FUJIX Co. KING FIT #60 (Synthetic thread)		ACE CROWN Tetoron #8	KANAGAWA Co. KNK400mZ FUJIX Co. KING FIT #60 (Synthetic thread)
8	Thread length	Sewing thread 1,200 mm or less		Sewing thread 1,000 mm or less	Sewing thread 1,200 mm or less
9	Type of stitch	Short-long stitch 		Saddle stitch 	
10	Feed type	Top and bottom feed type			
11	Change-over of upper and lower stitch mechanism (Cloth feed mechanism)	Change of upper and lower stitch feed amount by a stepping motor			
12	Threading	Manual operation			
13	Presser foot lifting method	By a knee-lifter lever			
14	Presser foot lift	7 mm (when the knee-lifter lever is used)			
15	Material thickness	Max. 2.5 mm			
16	Safety mechanism	Drum cover open / close protection switch (when opening the drum cover, the sewing machine is not actuated even when the foot pedal is depressed.)			
17	Lubricating oil	JUKI New Defrix Oil No. 2 (equivalent to ISO VG32)			
18	Grease	ESSO TEMPLEX Grease N2 containing 10g (Part No. 13552206)			
19	Dimensions	Main unit : 1,070 mm (width) X 660 mm (depth) (FLS-350N : 715 mm) X 1,120 mm (height) Table : 1,200 mm (width) X 800 mm (depth) X 870 to 910 mm (height)			
20	Weight of machine	300Kg			
21	Input power voltage	Single phase : 100V, 200V 50 / 60 Hz	Single phase : 200V, 220V, 230V, 240V, 380V, 50 / 60 Hz 3-phase : 200V, 220V, 230V, 240V, 380V, 50 / 60Hz		
22	Power consumption	700W			
23	Motor	SC-1	SC-380		

* It is necessary to change the needle bar when changing the needle size.

2. EXPLANATION OF UNITS

(1) Configuration

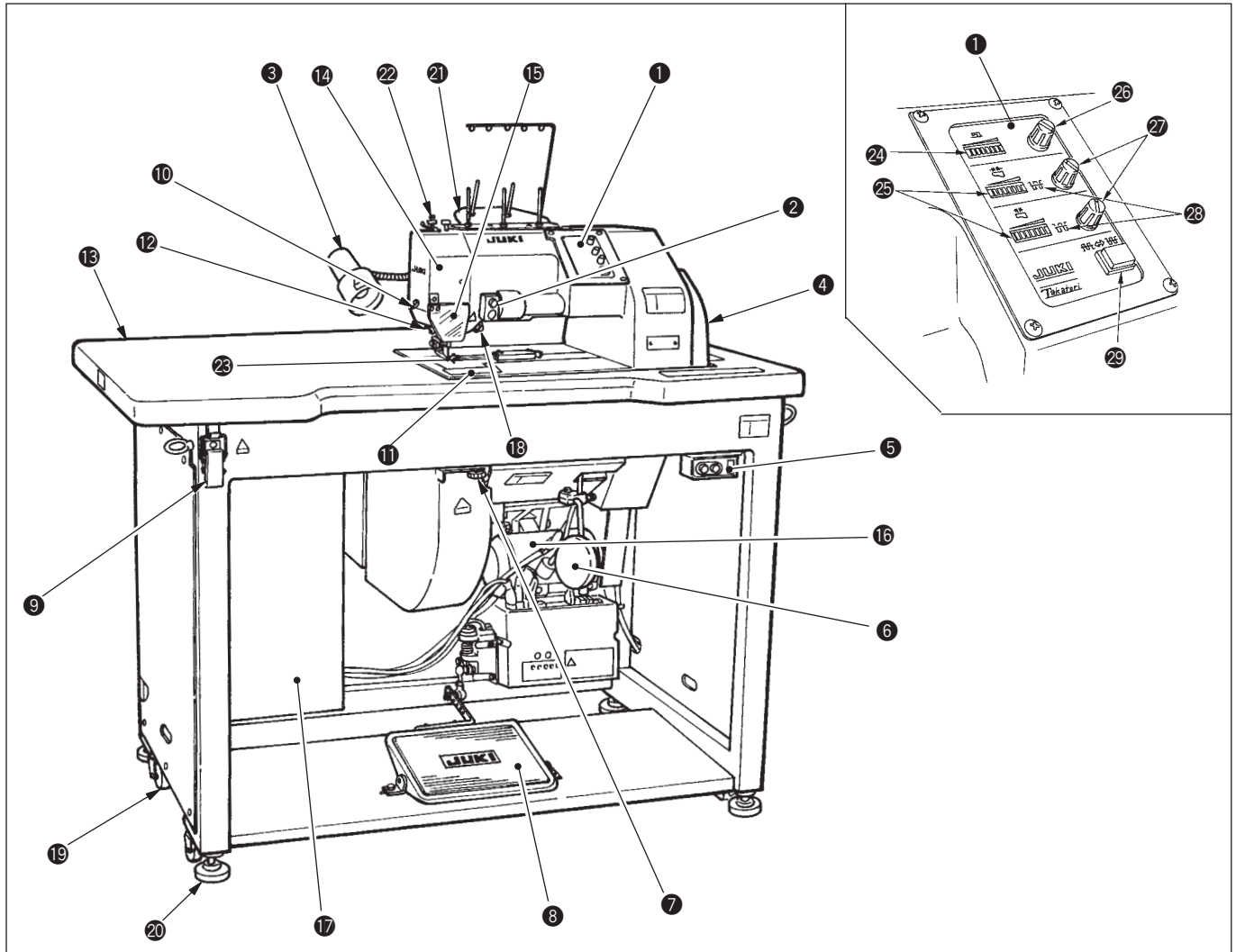

① Operation panel

② Reverse stitch switch

- The machine performs reverse stitching as long as the push-button is held pressed. The machine resumes normal stitching when the push-button is released.

(Caution) Reverse stitching should be carried out at the lowest speed within the range of 1 to 3 stitches.

③ Sewing machine light

- It lights up when turning the knob mounted on the top of the lamp.
- The lamp support rod is flexible and can be tilted as desired.

(Caution) Unless the power switch is turned ON, the lamp will not light up since the lamp is not energized.

④ Handle

This handle can be operated manually.

⑤ Main power switch

- Press the "1" side of the switch, and the control circuit will be energized.
The indicator lamps on the control panel will light up, and the motor that controls the feed mechanism and the sewing machine will be actuated to retrieve the origin.
- Press the "0" side of the switch, and the power to the machine will be turned OFF.

⑥ Knee-lifter lever

Shift the lever to the right, and the presser foot will go up.

⑦ Drum cover opening/closing knob

When loosening the knob and opening the cover, the safety device will be actuated, and the sewing machine will not be actuated even when the foot pedal is depressed.

8 Sewing machine foot pedal

- The machine changes the sewing speed from low to high by gradually increasing depressing the front part of the foot pedal.
- After releasing the foot pedal, the needle will stop at the intermediate resting position in its stroke. (The needle has two different intermediate resting positions.)
- When this side of the foot pedal is depressed, the needle will stop at the upper position.
- The lowest speed is fixed at 140 rpm (120 rpm) (Depending on the specifications).

9 Table fixing clip

- It is used when opening/closing or fixing the machine table.

10 Presser lifter fixing knob

- The presser foot and the top feed dog can be fixed with this knob.

11 Slide plate

- The drum and underside of the throat plate can be observed by shifting the slide plate.

12 Thread trimming blade

- The blade is used to cut and hold the thread.

13 Table

14 Head cover

- Open the head cover when replacing the needle.
- Open the head cover when disassembling the needle bar for cleaning.

15 Eye-guard

- It is a cover that protects eye from a broken needle that jumps out of position.

16 AC servo-motor

17 Control box

18 Needle threading lever

- It is used to thread the needle.

19 Caster

20 Adjusting bolt

21 Thread stand (packed in the accessory box)

22 Thread guide

- This is a guide that works when drawing thread placed on the spool rest rod.

23 Stitch ruler

(2) Operation panel (1 Operation panel)

24 Sewing speed LED indicator

The LED lights up to indicate the sewing speed specified by the setting variable resistor locating on the right of the LED.

25 Stitch length LED indicator

The LED lights up to indicate the stitch length specified by the setting variable resistor locating on the right of the LED.

26 Sewing speed setting variable resistor

Turning this variable resistor clockwise will increase the number of revolutions.

27 Stitch length setting variable resistor

Turning this variable resistor clockwise will increase the stitch length.

28 Right side/wrong side stitch indicator

This indicates whether the stitch length is on the upper side or on the lower side.

29 Stitch selector switch

Pressing the push-button switch changes the right side stitches to the wrong side stitches.

3. EXPLANATION OF STITCH LENGTH COMPENSATION FUNCTION

(1) Function

When changing over the upper stitch length or the lower stitch length (turn ON/OFF the stitch length changing switch.), it is ideal if the stitches are as illustrated in the figure below.

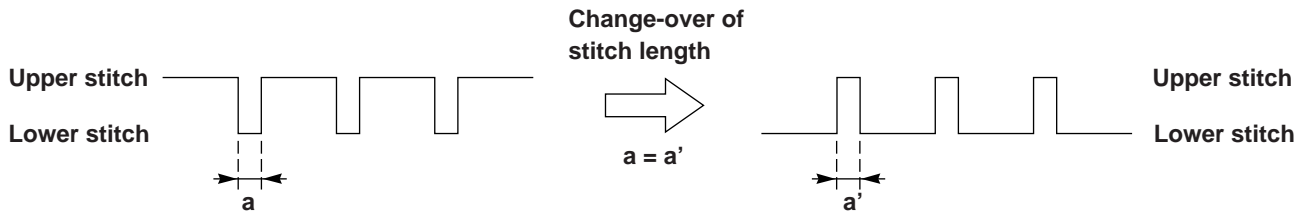

However, there may rarely be some machines, which make the stitches as shown in the figure below when the short stitch length is changed to upper stitch or lower stitch.

1) In case the upper stitch becomes small

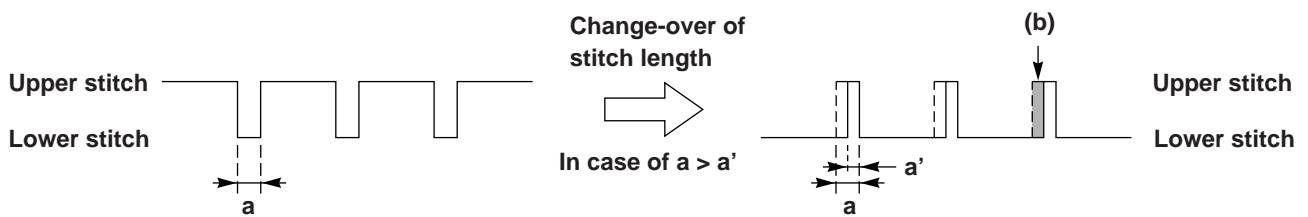

2) In case the upper stitch becomes large

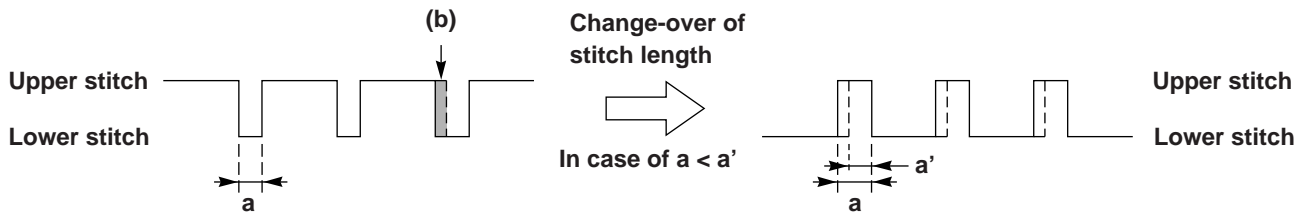

As shown in the above figure, the upper stitch is not the same as the lower stitch when the stitch length is changed.

At this time, adjust the stitch length changing variable resistor so that the upper and lower stitches become the same by adding the stitch length of section (b) of the above figure.

(2) Operation

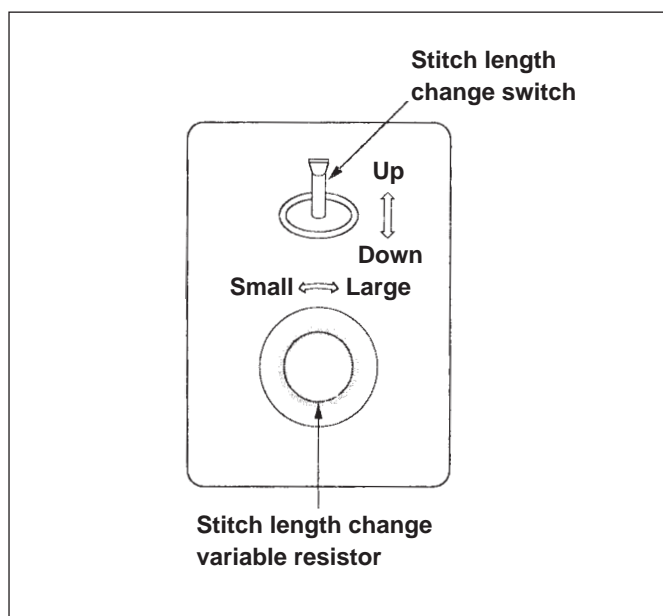

1) In case of $a > a'$

① In case of $a > a'$, the lower stitch is larger than the upper stitch. Add the compensation amount to the upper stitch length.

In this case, press up the stitch length change switch, and adjust the stitch length change variable resistor so that the lower stitch becomes the same as the upper stitch.

2) In case of $a < a'$

② In case of $a < a'$, add the compensation amount to the lower stitch length as the upper stitch is larger than the lower stitch.

In this case, press down the stitch length change switch, and adjust the stitch length change variable resistor so that the lower stitch becomes the same as the upper stitch.

4. NEEDLE BAR CURVE AND TIMING ADJUSTMENT CHART

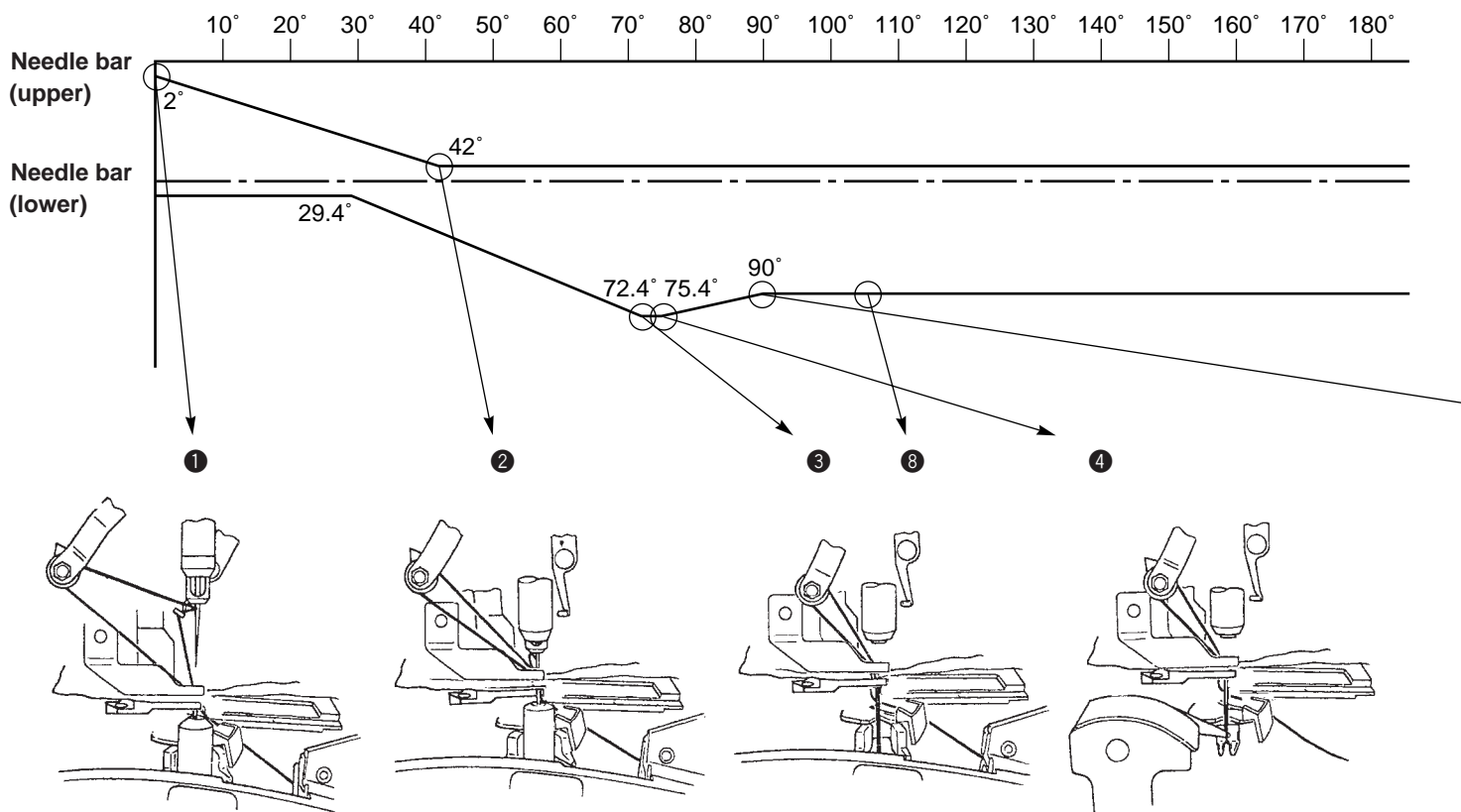

Points to be adjusted for each timing

1	2	3	4
<ul style="list-style-type: none"> Adjusting the home position (5.-(2)) Adjusting the needle bar groove cam and the left looper cam (5.-(3)) Adjusting the lower feed (5.-(12)) Adjusting the feed eccentric boss and the lifting cam (5.-(12)-1) Adjusting the presser (5.-(14)) 	<ul style="list-style-type: none"> Adjusting the height of the upper needle bar support cylinder (5.-(4)-1)) Adjusting the height of the lower needle bar support cylinder (5.-(4)-2)) Adjusting the timing of transferring the needle (5.-(4)-3)) Centering the needle bar (5.-(4)-4)) 	<ul style="list-style-type: none"> Adjusting the needle and the needle guide claws (5.-(5)-1)) Adjusting the timing of opening/closing the tubular cam of the needle guide claw (5.-(5)-3)) Adjusting the thread tension of the needle guide claws (5.-(5)-2)) 	<ul style="list-style-type: none"> Adjusting the lower looper (5.-(20))

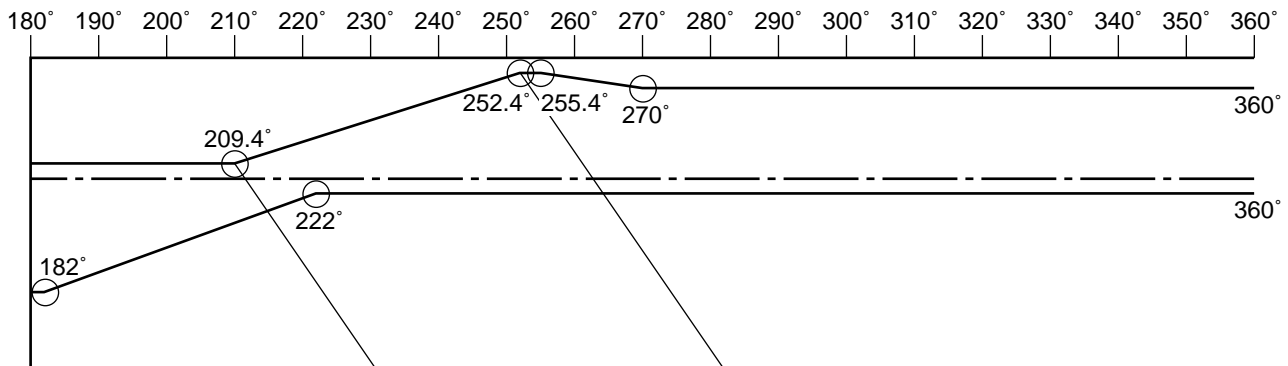

5

6

7

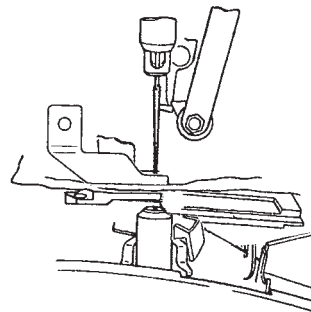
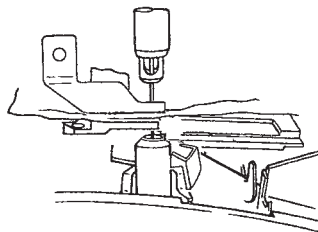
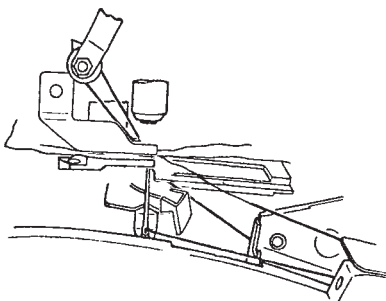

5	6	7	8
<ul style="list-style-type: none"> Adjusting the thread haul lever (5.-(7)) 	<ul style="list-style-type: none"> Adjusting the thread path guide (5.-(6)) Adjusting the hook finger (5.-(9)) Adjusting the hook finger to release the thread tension (5.-(10)) 	<ul style="list-style-type: none"> Adjusting the left looper (5.-(16)) Adjusting the right looper cam (5.-(17)) Adjusting the right looper (5.-(18)) 	<ul style="list-style-type: none"> Adjusting the brush cam (5.-(8))

5. STANDARD ADJUSTMENT

(1) Before making the adjustments

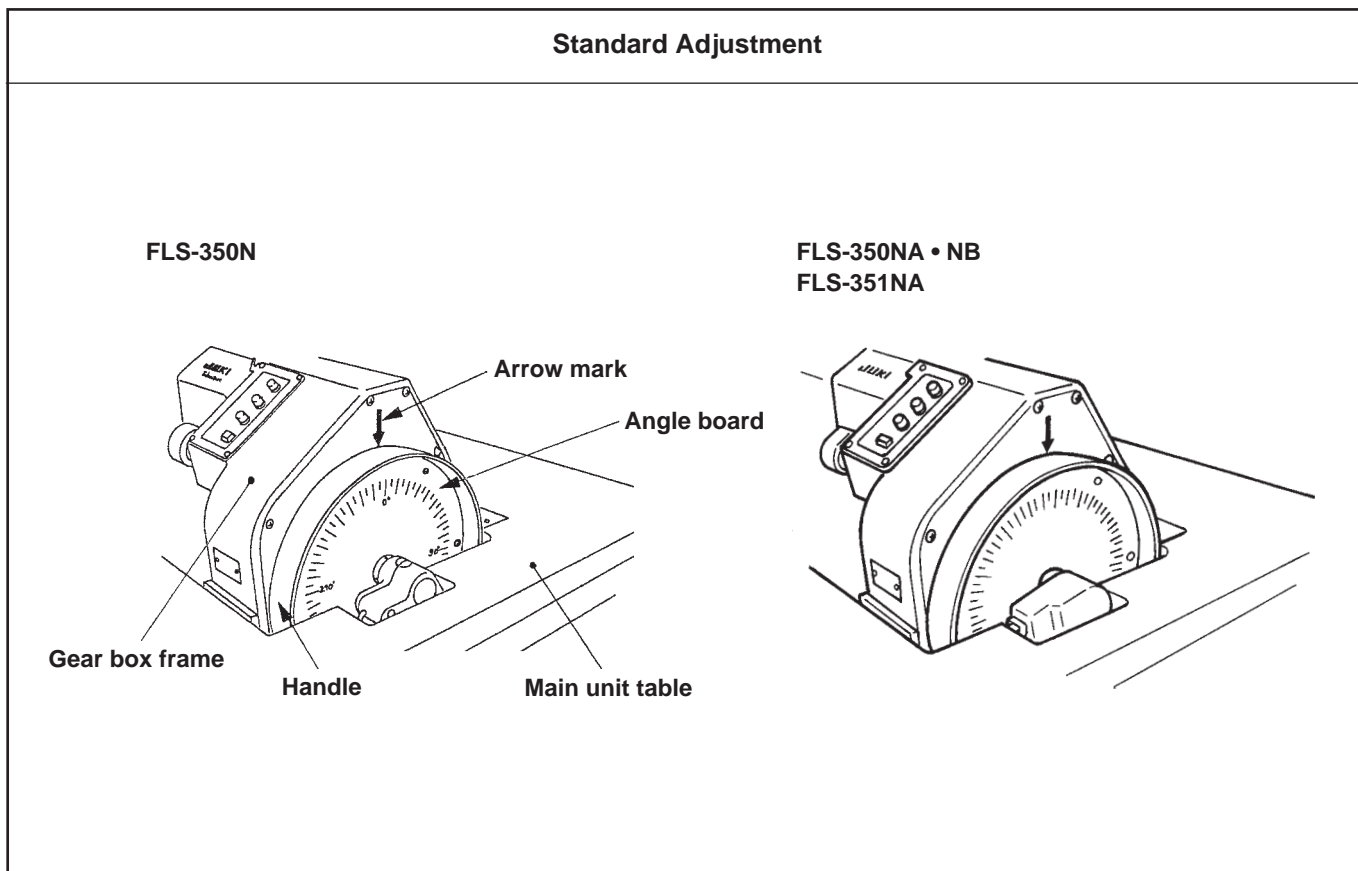

(2) Adjusting the home position (adjusting the graduation)

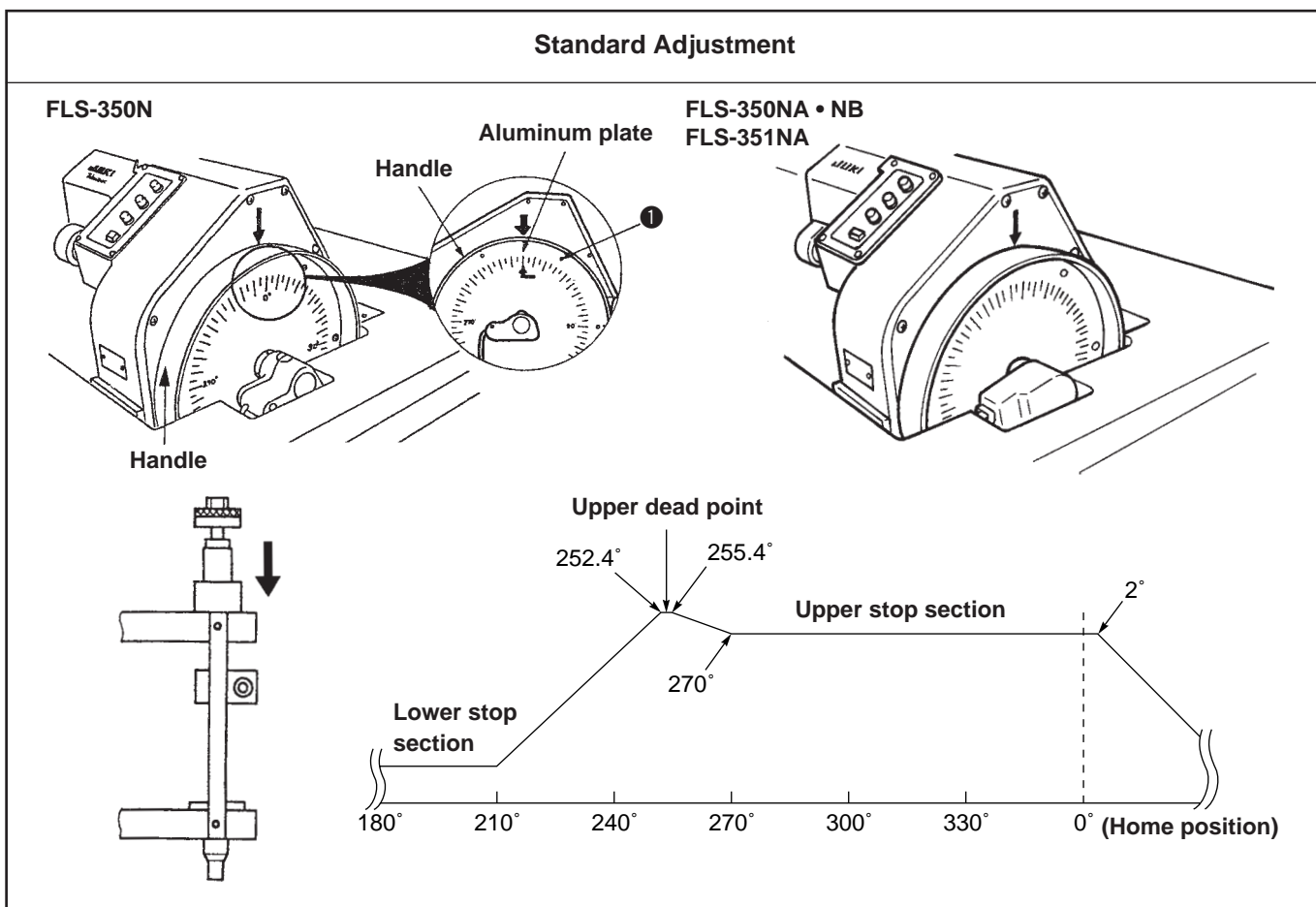

Adjustment Procedures	Results of Improper Adjustment
<p>Adjustment of the respective functions is indicated by angle board affixed to the surface of the handle.</p> <p>Angle indicated by the arrow mark on the gear box cover is the angle shown in the respective adjustment procedures.</p>	

Adjustment Procedures	
<p>The home position is indicated by “ 0° ”, and the standard of all timing adjustments. The home position alignment is performed by determining the 2° position.</p> <p>Adjustment procedure</p> <ol style="list-style-type: none"> 1) Turn the handle, and stop the needle bar when it starts coming down from the upper stop position. At this time, loosen the setscrews (6 pcs.) in the angle board ❶ so that the arrow mark points to 2°. After adjusting the position, fix the angle board. The upper stop position is slightly lower than the upper dead point, and located at a place where the height of the needle bar does not change for a certain section. Be careful not to mistake it for the upper dead point. 2) Turn the handle. The place where the arrow mark points to “ 0° ” is the home position. 	<ul style="list-style-type: none"> ○ If the home position shifts, the timing adjustment cannot be made.

(3) Adjusting the needle bar groove cam and the left looper cam

Standard Adjustment

FLS-350N

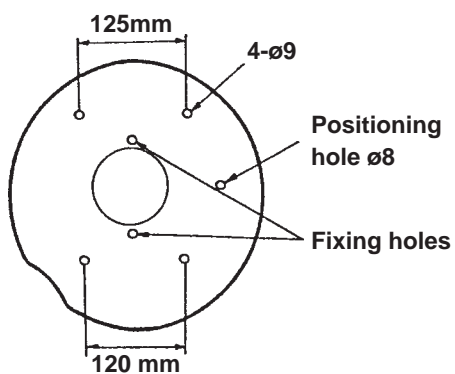
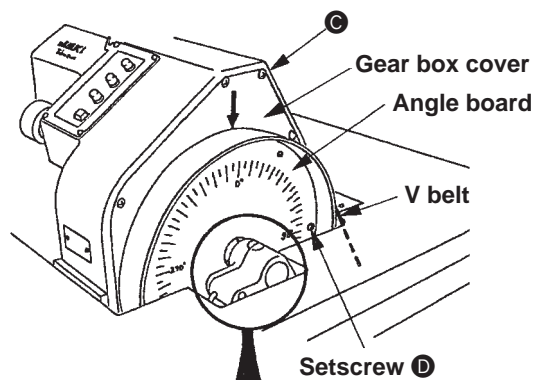
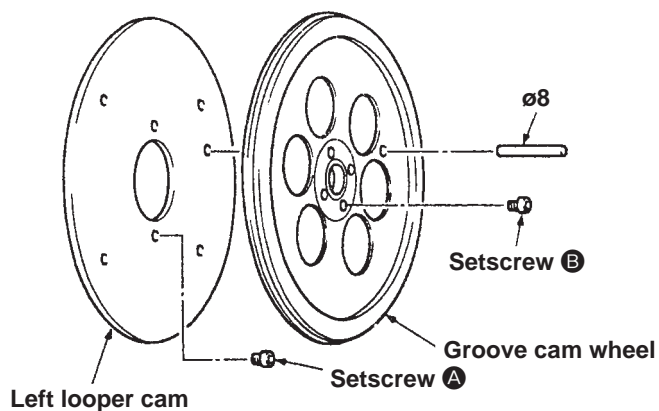

Left looper cam configuration

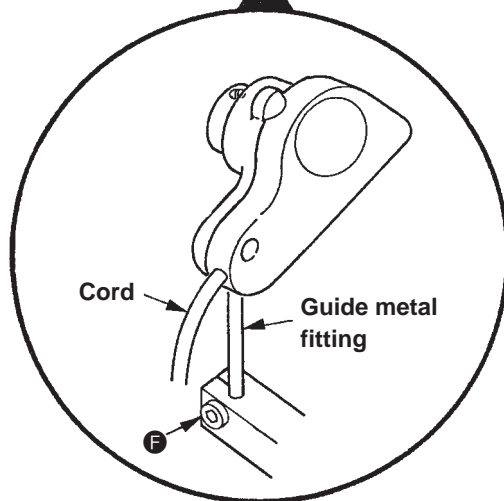

FLS-350NA • NB
FLS-351NA

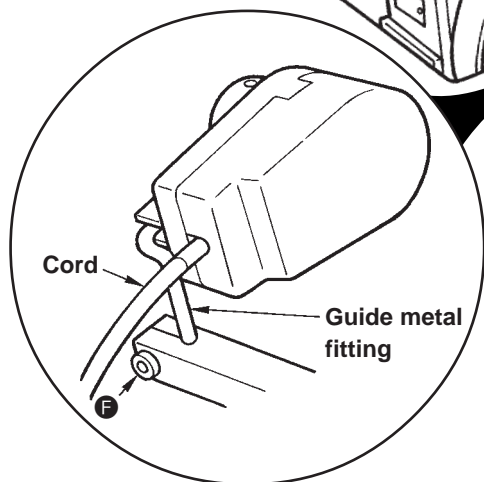
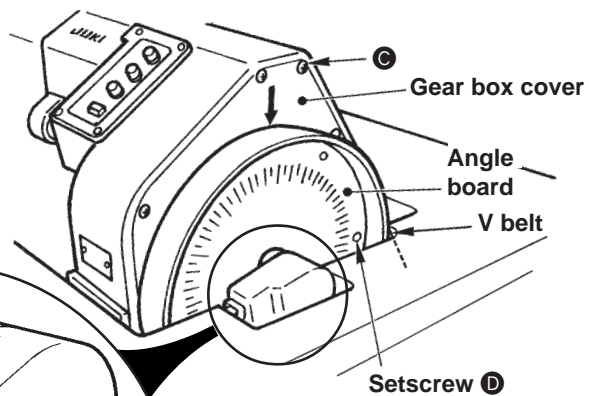

Adjustment Procedures	Results of Improper Adjustment
<p>Disassembly procedure</p> <ol style="list-style-type: none"> 1) Loosen setscrew C, and remove the gear box cover. 2) Loosen setscrew F, and turn the guide metal fitting fixing the synchronizer. Then remove the synchronizer. 3) When loosening setscrew D located inside the angle board, the handle and synchronizer can be removed together. 4) Remove the V belt. 5) Remove setscrew B in the groove cam wheel, and draw out the groove cam wheel from the center shaft. 6) Loosen setscrew A, and remove the left looper cam. <p>Assembly procedure</p> <p>In case of FLS-350N</p> <ol style="list-style-type: none"> 1) Bring the left looper cam setscrew tap to the up and down position of the rotating shaft. 2) Install the left looper cam as illustrated in the figure, and tighten setscrew A. (Place the left looper cam fixing holes and the tap at the same positions as when they were removed.) 3) When attaching the groove cam wheel, insert a $\varnothing 8$ pin supplied as an accessory into the hole in the groove cam wheel. After adjusting the position of the groove cam wheel and the left looper cam, tighten setscrew B. When setting the groove cam wheel on the left looper cam, first fit it over the center shaft. Then fit the cam follower in the groove of the groove cam while pressing the lower cam follower outward (the upper cam follower can be easily fitted in the groove). After both cam followers have been properly fitted in the groove, position them quietly taking care not to allow them to come in contact with each other. When attaching the handle, allow the $\varnothing 8$ positioning hole in the left looper cam to face exactly toward the right-hand side, and allow the 0° scale of the angle board to face upward. Refer the adjustment to item 5-(2) "Adjusting the home position".) When the positioning holes of the left looper cam and the groove cam wheel are faced exactly toward the right-hand side, the upper end section becomes "0°". <p>In case of FLS-350NA • NB and FLS-351NA</p> <ol style="list-style-type: none"> 1) Bring the left looper cam setscrew tap to the up and down position of the rotating shaft. 2) Install the left looper cam as illustrated in the figure, and tighten setscrew A. (Place the left looper cam fixing holes and the tap at the same positions as when they were removed.) 3) When attaching the groove cam wheel, insert a $\varnothing 8$ pin supplied as an accessory into the hole in the groove cam wheel. After adjusting the position of the groove cam wheel and the left looper cam, tighten setscrew B. When setting the groove cam wheel on the left looper cam, first fit it over the center shaft. Then fit the cam follower in the groove of the groove cam while pressing the lower cam follower outward (the upper cam follower can be easily fitted in the groove). After the both cam followers have been properly fitted in the groove, slowly place the groove cam until it will go no further taking care not to allow them to come in contact with each other. When attaching the handle, allow the $\varnothing 8$ positioning hole in the left looper cam to face exactly toward the right-hand side, and allow the 0° scale of the angle board to face upward. Refer the adjustment to item 5-(2) "Adjusting the home position".) When the positioning holes of the left looper cam and the groove cam wheel are faced exactly toward the right-hand side, the upper end section becomes "0°". 	<ul style="list-style-type: none"> ○ If the position shifts, the timing between the left looper cam and the needle bar shifts, and they come in contact with each other.

(4) Adjusting the needle bar

Standard Adjustment

1) Adjusting the height of the support cylinder of the upper needle bar

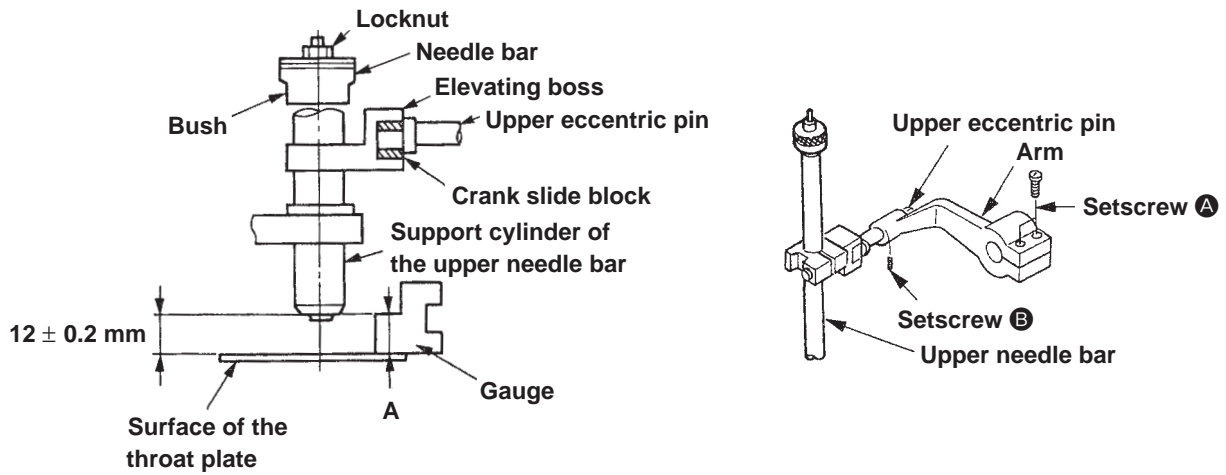

2) Adjusting the height of the support cylinder of the lower needle bar

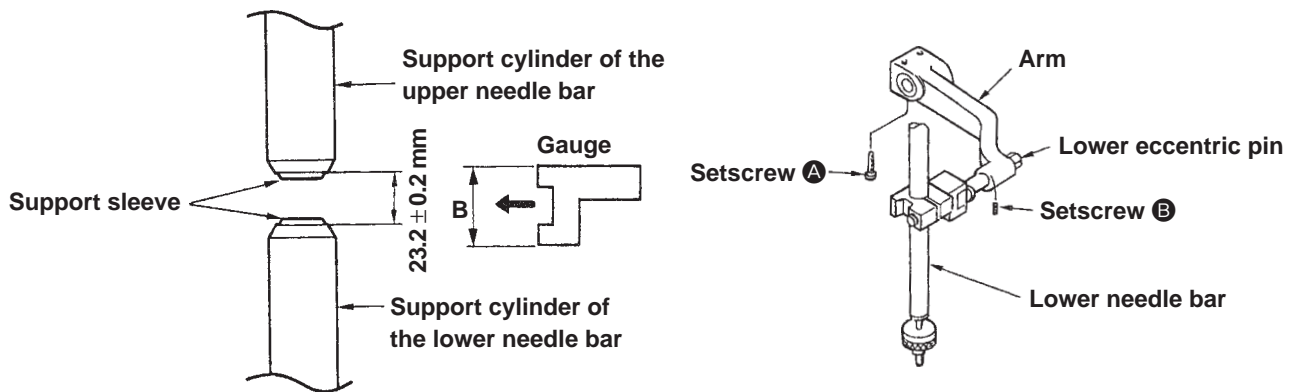

Adjustment Procedures	Results of Improper Adjustment
<p>Bring the support cylinder of the upper needle bar to its lower stop position (within the range of 42° to 209.4°). Loosen two setscrews A, and adjust so that a distance of 12 ± 0.2 mm is obtained between the throat plate and the support cylinder. When finely adjusting the distance, loosen setscrew B, and turn the upper eccentric pin. Dimension A of the gauge is 12 mm.</p>	<ul style="list-style-type: none"> ○ If the height shifts, needle transferring cannot be properly made, causing needle breakage.
<p>Adjust so that the distance from the support cylinder of the upper needle bar to the support cylinder of the lower needle bar is 23.2 ± 0.2 mm when they come closest to each other in their stroke (35° to 37°). Loosen setscrew A, and using the gauge adjust the height of the support cylinder of the lower needle bar. When finely adjusting the height of the support cylinder of the lower needle bar, loosen setscrew B, and turn the lower eccentric pin. Apply the minus tolerance when adjusting the distance between the support cylinders when they come closest to each other in their stroke Open the throat plate on the left-hand side, and use the gauge with turned upside down. Dimension B of the gauge is 23 mm. * Perform this adjustment after checking that 4-(4)-1) "Adjusting the height of the support cylinder of the upper needle bar" has been performed.</p>	<ul style="list-style-type: none"> ○ If the closest distance shifts, needle transferring cannot be properly made, causing needle breakage.

Standard Adjustment

3) Adjusting the timing of transferring the needle

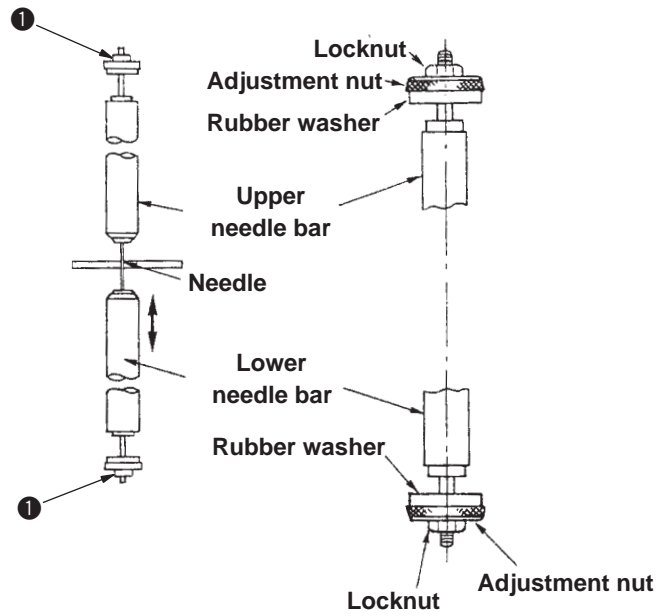

4) Centering the needle bar

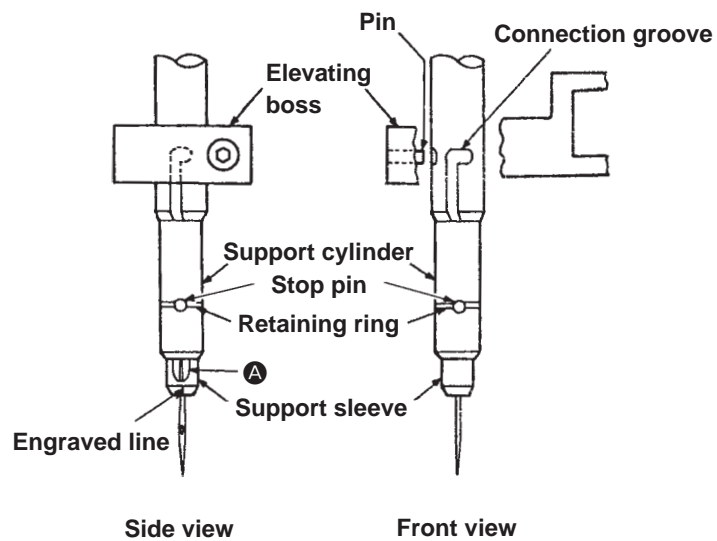

Adjustment Procedures	Results of Improper Adjustment
<p>Loosen the upper and lower locknuts ❶ to loosen the adjustment nuts. Turn the handle by hand to bring the needle to the transfer position.</p> <p>1) Adjusting the upper needle bar components</p> <ul style="list-style-type: none"> ❶ The needle is transferred from the upper needle bar to the lower needle bar. ❷ Turn the adjustment nut counterclockwise until the needle nearly leaves the upper needle bar. (Turning the adjustment nut counterclockwise will bring the needle to a position where it will remain in the upper needle bar, or turning the nut clockwise will bring the needle to a position where it will leave the upper needle bar. Find a position in between the aforementioned two positions.) ❸ Give the adjustment nut a 1/2 to 3/4 clockwise turn, and fix the nut with the locknut. <p>2) Adjusting the lower needle bar components</p> <ul style="list-style-type: none"> ❶ When the needle is transferred from the lower needle bar to the upper needle bar, bring the needle to the position where it nearly leaves the lower needle bar as in the case of transferring the needle from the upper needle bar to the lower needle bar. Then give the adjustment nut a 1/2 to 3/4 counterclockwise turn, as viewed from above. Then fix the adjustment nut with the locknut. <p>After the adjustment, penetrate the needle into the material to check that the needle is securely caught.</p>	<ul style="list-style-type: none"> ○ Check that the needle does not move up or down (from up to down, from down to up) after transferring the needle. ○ Check the catching of the needle when the material used becomes thick. If the catching is not proper, causing needle breakage. To confirm, check whether the threading needle smoothly enters the needle eyelet.
<p>After disassembling the needle bar or if stitch wobbling or upper/lower irregular stitch length occurs, adjust the center of the needle bar.</p> <p>1) Adjusting the center of the needle bar using the support cylinder Change the direction of the groove of the needle bar connection of the elevating boss by 90°. At this time, draw out the retaining ring and stop pin from the support ring, and also change the direction of the support sleeve by 90°.</p> <p>2) Adjusting the center of the needle bar using the support sleeve If the direction of the needle bar connection is not changed, change the direction of the support sleeve by 180°. Perform adjustment 1) or 2), and align the center of the upper needle bar with the center of the lower needle bar. Carefully check the direction of the support sleeve. (The long groove in section ❶ should look sideways as observed by the operator.) An engraved line has been made at the time of delivery. So use it as reference when disassembling or assembling the needle bar.</p>	<ul style="list-style-type: none"> ○ If the adjustment is not proper, wobbling and irregular stitch length will occur.

(5) Adjusting the needle guide claw

Standard Adjustment

1) Adjusting the needle and the needle guide claw

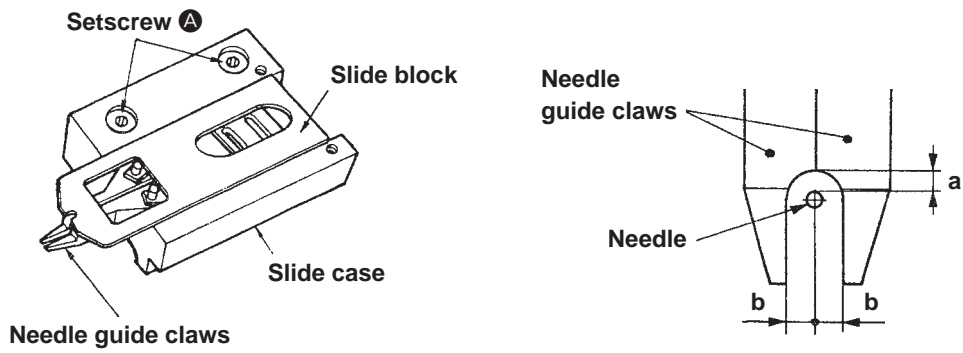

2) Adjusting the thread tension of the needle guide claw

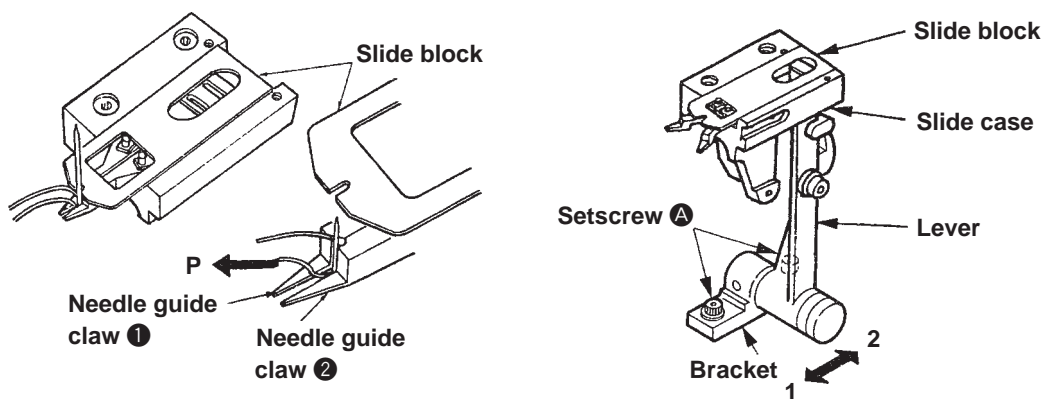

Adjustment Procedures	Results of Improper Adjustment
<p>Close the needle guide claws, move the slide case, and make closer the clearance “a” between the needle and the needle guide claws as narrow as possible so that the needle does not come in contact with the needle guide claws. At this time, tighten setscrew A so that the clearances of the left and right sides “b” become equal.</p>	<ul style="list-style-type: none"> ○ Position of the needle guide claws is not proper, the needle guide claws come in contact with the needle, or the needle guide claws do not catch the thread.
<p>Adjust the thread tension of needle guide claws ① and ② at the position where they grasp the thread (reference 86° to 166°).</p> <ol style="list-style-type: none"> 1) When the needle guide claws grasp the thread, pull the thread in direction P from between the slide block and the needle guide claws. At this time, measure the thread tension using a spring balancer, and adjust so that the thread tension is 500 to 1,200g. 2) When adjusting, loosen setscrews A in the bracket, and move the bracket in direction “2” to increase the thread retaining force, or move the bracket in direction “1” to decrease the force. <p>The thread retaining force greatly changes if greatly moving the bracket. It is, therefore, necessary to move it by approximately 0.1 mm steps.</p> <p>Check after the adjustment that the section where the needle guide claws are completely closed (approx. 86° to 166°).</p>	<ul style="list-style-type: none"> ○ If thread retaining force of the needle guide claws is weak, causing loose stitch or thread breakage. On the other hand, when the bracket is extremely moved to the direction “2”, the section where the needle guide claws are closed becomes longer, and the claws may come in contact with the needle bar. So, be careful.

Standard Adjustment

3) Adjusting the timing of opening/closing the tubular cam of the needle guide claw

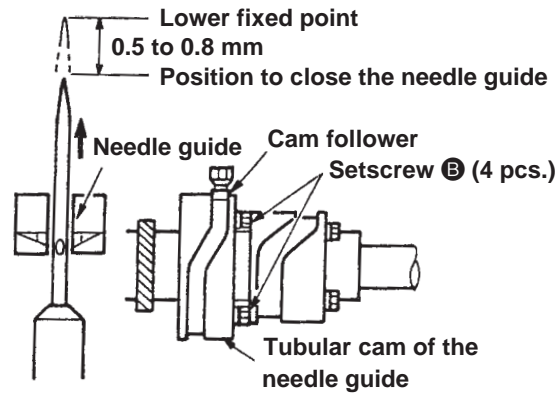

(6) Adjusting the thread path guide

Standard Adjustment

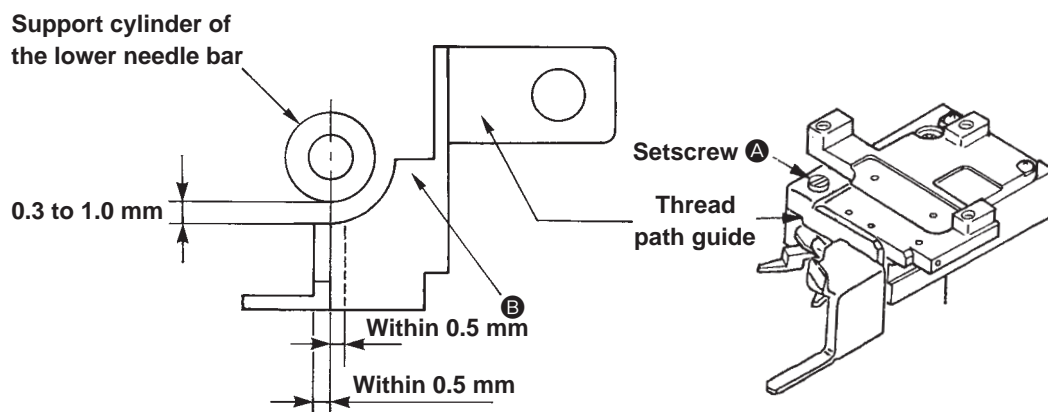

Adjustment Procedures	Results of Improper Adjustment
<p>1) Turn the handle until the needle guide claws are brought to the position where they start closing.</p> <p>2) Loosen four setscrews (B), turn the tubular cam of the needle bar guide (reference value : 86°), and adjust so that the needle guide claws completely close at the position of 0.8 to 0.5 mm before the lower needle bar reaches its lower fixed position.</p> <p>* When the needle guide claws are closed, check that the guide claws have no play by moving the guide claws back and forth by hand.</p>	<ul style="list-style-type: none"> ○ If the timing shifts, the needle guide comes in contact with the needle bar or the needle guide does not catch the thread.

Adjustment Procedures	Results of Improper Adjustment
<p>Loosen setscrew (A) and adjust so that the edge of the thread path guide is within 0.5 mm away from the upper position of the center of needle. Then adjust so that a 0.3 to 1.0 mm clearance is obtained between the thread path guide and the support cylinder of the lower needle bar. After making the adjustment, tighten setscrew (A). Check that the thread passes inside of the thread path guide (side (B)) when the thread comes off the drum.</p>	<ul style="list-style-type: none"> ○ If the clearance is large : The thread does not enter the thread path guide, causing thread breakage. ○ If the clearance is small : The thread path guide comes in contact with the support cylinder of the lower needle bar, causing thread path guide breakage.

(7) Adjusting the thread haul lever

Standard Adjustment

1) Cam timing

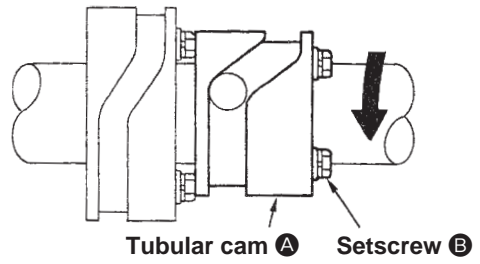
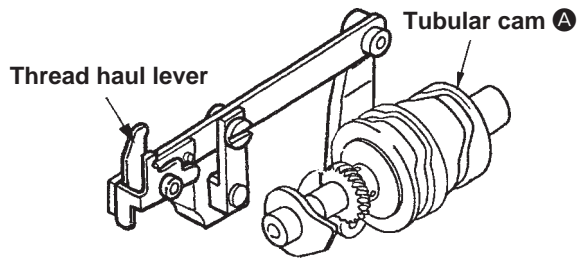

2) Adjusting the thread haul lever

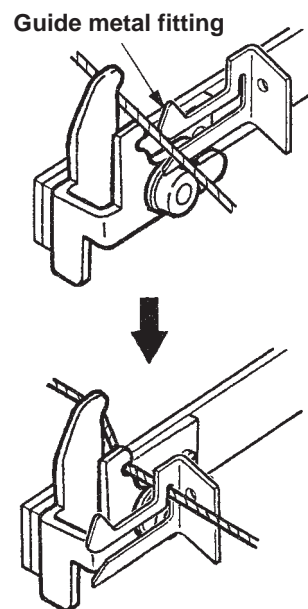
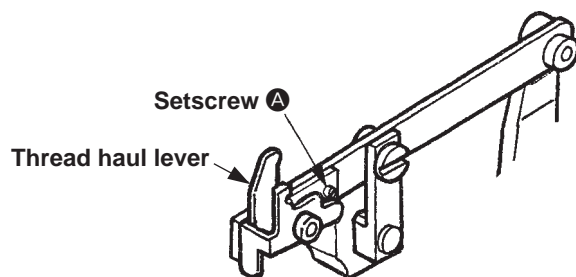

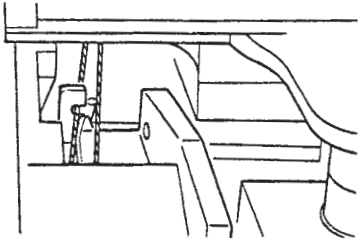
Adjustment Procedures	Results of Improper Adjustment
<p>1) Turn the handle until the thread haul lever is brought to the position where it starts moving from the left end to the right.</p> <p>2) Loosen setscrew B, and turn tubular cam A. Then tighten setscrew B. Make this position 110° to 125°.</p> <p>* After the adjustment, check that the thread that the lower looper scooped enters the drum.</p>	<p>○ If the timing shifts, causing the thread not to enter the drum.</p>
<p>Loosen setscrew A, and adjust so that the difference in height between the top end of the thread haul lever and the top end of the guide metal fitting is set to 1 to -3 mm when the top end of the thread haul lever reaches its lowest end.</p> <p>Make the thread approach inside the drum using the thread haul lever. At this time, if the thread comes off the drum, decrease the difference in height between the thread haul lever and the guide metal fitting so that the clearance between them is reduced. This will allow the needle to smoothly enter the drum.</p> <p>* After the adjustment, check that the thread haul lever does not come in contact with the lower looper.</p>	<p>○ If the adjustment is not proper, the thread does not enter the guide metal fitting (drum).</p> 

(8) Adjusting the brush cam

Standard Adjustment

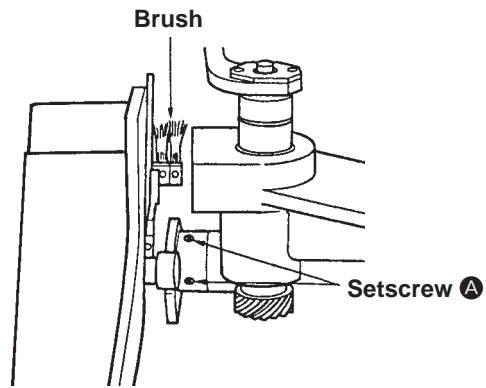

(9) Adjusting the hook finger

Standard Adjustment

1) Adjusting the movement amount of the hook finger

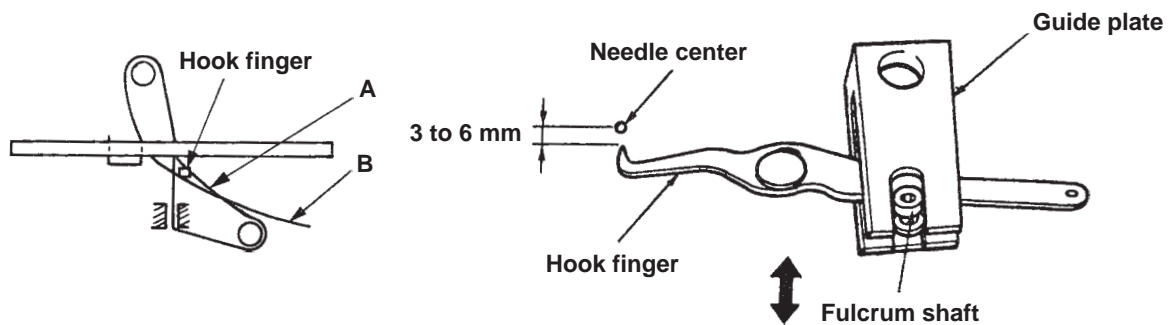

Adjustment Procedures	Results of Improper Adjustment
<p>Loosen setscrew A in the brush cam, and adjust the brush cam so that the brush fully closes when the handle is turned until the machine is brought to the position of 185° (reference value).</p>	<ul style="list-style-type: none"> ○ If the timing is too early : The brush closes before the thread enters the inside of the drum. ○ If the timing is too late : The thread comes off the drum.

Adjustment Procedures	Results of Improper Adjustment
<p>Loosen the fulcrum shaft of the guide plate so that a 3 to 6 mm clearance is obtained from the center of the needle to the top end of the hook finger when the hook finger comes nearest to the operator in its stroke.</p> <p>Adjust so that the top end of the hook finger is aligned with the tip of the needle when the hook finger returns to its home position.</p> <p>Angle of the timing, when the needle is lowered, is (reference: 88°).</p> <p>Keep the rotating shaft in the standard state.</p> <p>After the adjustment, turn the handle by hand, and check that the needle does not come in contact with the hook finger.</p> <p>Check that the top end of hook finger enters between thread A coming from the drum in the minimum stitch length and thread B entering the drum, and that the hook finger securely separates threads A and B.</p>	<ul style="list-style-type: none"> ○ If the clearance is too small : The needle comes in contact with the hook finger.

Standard Adjustment

2) Adjusting the rotating shaft and the tension spring

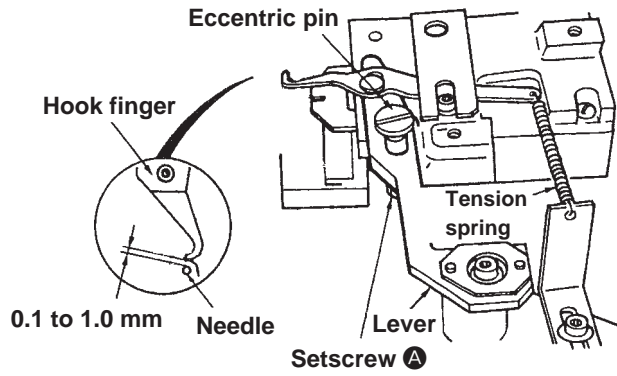

3) Adjusting the clearance between the hook finger and the needle

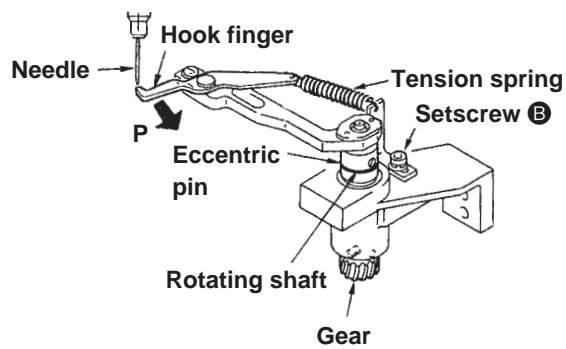

Adjustment Procedures	Results of Improper Adjustment
<p>Turn the handle, and turn the eccentric pin to adjust so that a 0.1 to 1.0 mm clearance is obtained between the hook finger and the needle when the hook finger comes nearest to the needle. Then tighten setscrew A.</p> <p>* Simultaneously adjust the item (9)-1) and 2).</p>	
<p>1) Loosen setscrew B, and adjust the tension spring so that the tension in direction P is 10 to 30g or less when the hook finger is located farthest from the operator side.</p>	

(10) Adjusting the hook finger to release the thread tension

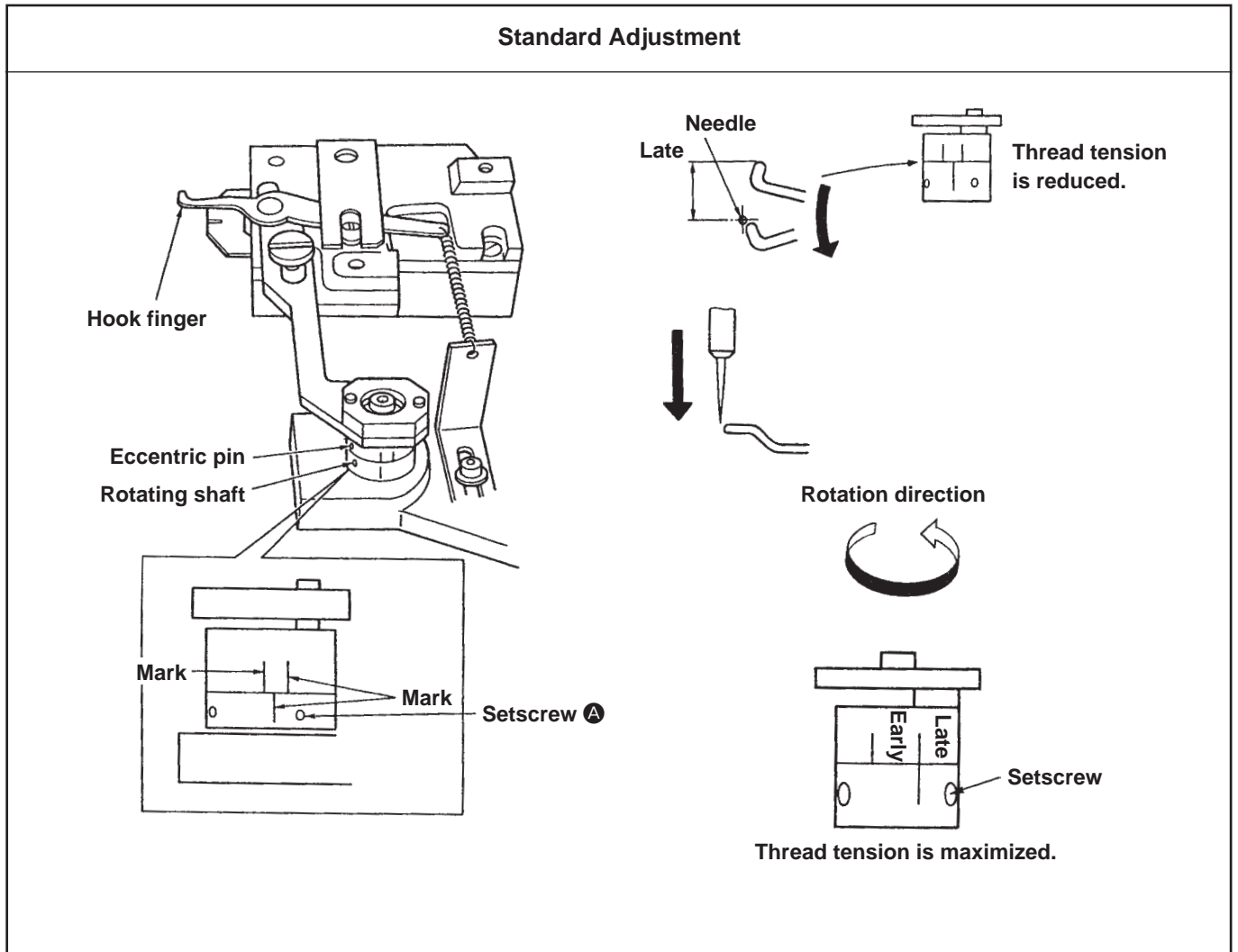

(11) Adjusting the eccentric amount of the eccentric pin

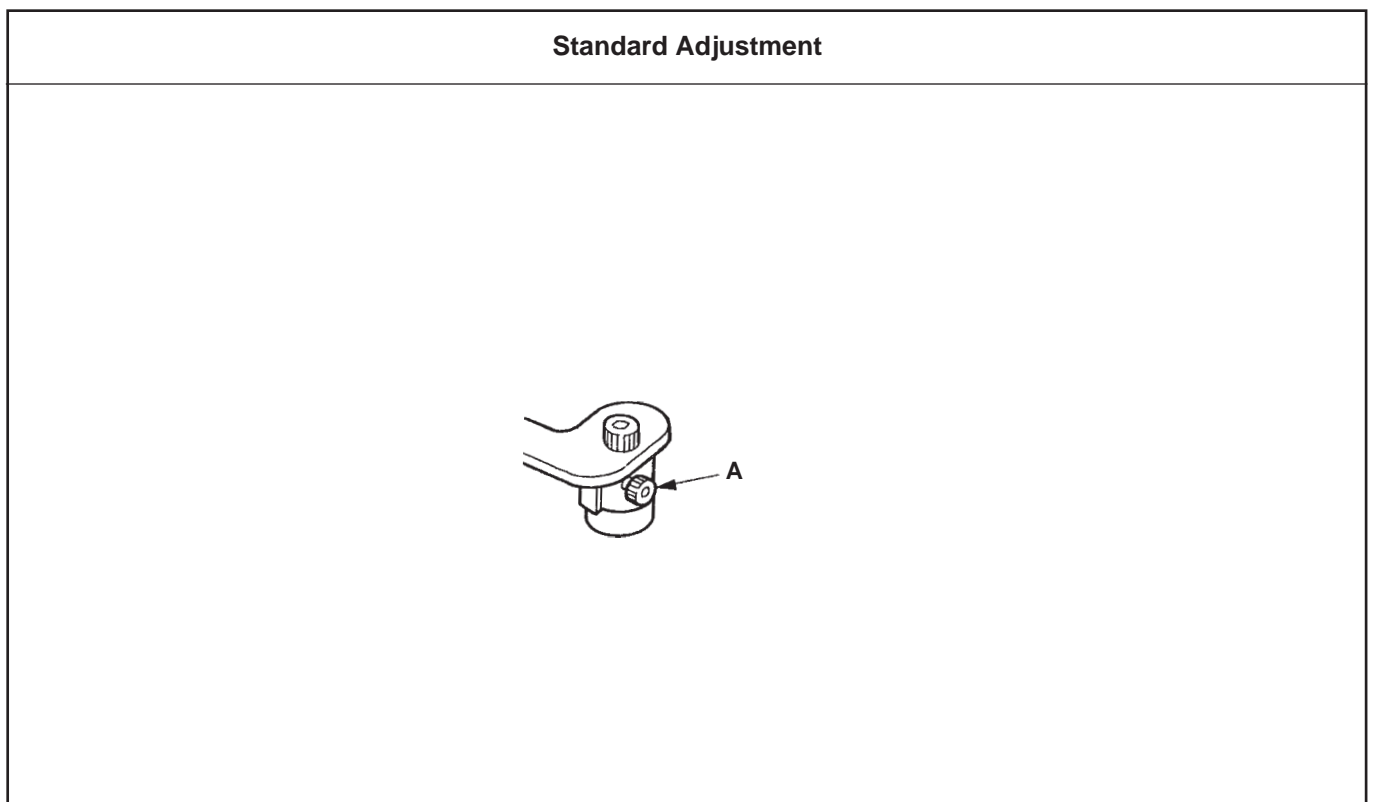

Adjustment Procedures	Results of Improper Adjustment
<p>1) Turn the handle to allow the mark of the rotating shaft and the marks on the eccentric pin to face toward you.</p> <p>2) The eccentric pin has two marks on its surface. The position of the eccentric pin can be adjusted within the range between the two marks. Loosen setscrew A in the rotating shaft and perform the adjustment by turning the eccentric pin. After the adjustment, tighten setscrew A.</p> <p>(Caution) Do not operate the machine with the mark on the rotating shaft set out of the range between the two marks on the eccentric pin.</p>	<p>If the timing to return the hook finger is excessively retarded, isolated idling loops may be formed.</p>

Adjustment Procedures	Results of Improper Adjustment
<p>1) If the total of upper/lower stitches exceeds 10 mm, loosen screw A to increase the eccentric amount. (To move to the right.)</p> <p>2) To release the thread tension, adjust it by shifting the timing of the hook finger. (Refer to the item (10).)</p> <p>* When the eccentric amount is shifted, simultaneously perform the adjustment of item (9) Adjusting the hook finger.</p>	<p>○ If the timing of the hook finger is retarded, thread tension is reduced, but isolated idling loops or the like are likely to be formed.</p>

(12) Adjusting the lower feed

Standard Adjustment

1) Adjusting the feed eccentric boss and the lifting cam

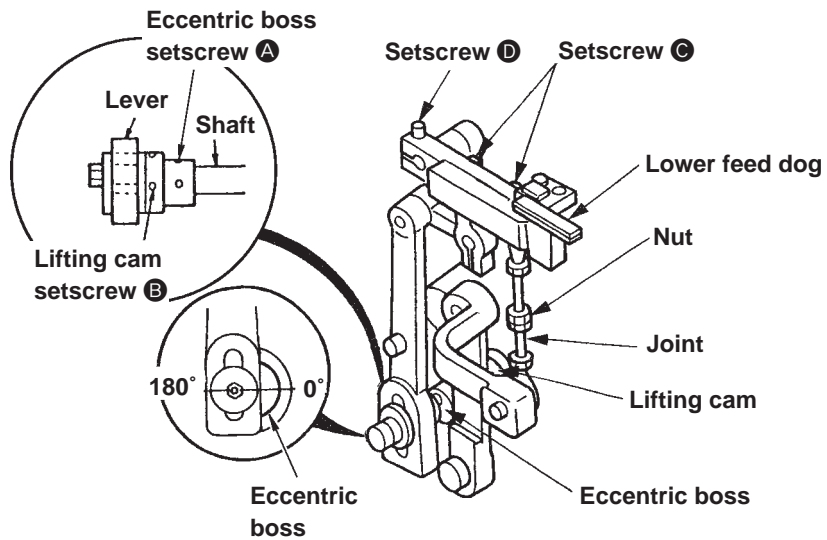

2) Adjusting the height of the lower feed dog and the throat plate

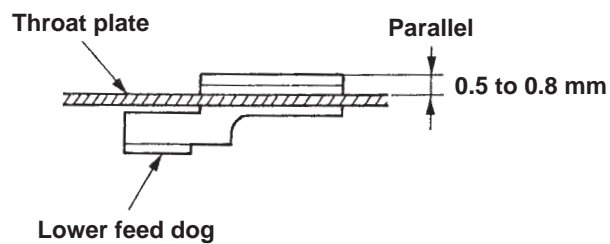

Adjustment Procedures	Results of Improper Adjustment
<ol style="list-style-type: none"> 1) Turn the handle to bring the machine to its home position (0°). 2) Loosen setscrew A of the eccentric boss, turn the eccentric boss by 180°, and fix it there. 3) Loosen setscrew B of the lifting cam and the lifting cam to the lowest position of the lower feed dog. Then tighten setscrew B. 	<ul style="list-style-type: none"> ○ If the upper feed is not synchronized with the movement, it will result in stitch slippage.
<ol style="list-style-type: none"> 1) Loosen the nut of the joint in the previous item 1), and adjust so that the lower feed dog protrudes from the throat plate by 0.5 to 0.8 mm. 2) Loosen setscrew C and adjust so that the lower feed dog is parallel to the throat plate, then tighten setscrew C. 	<ul style="list-style-type: none"> ○ If the lower feed dog is positioned lower than the specified amount, the material to be sewn may not be fed.

(13) Adjusting the upper feed dog and the lower feed dog

Standard Adjustment

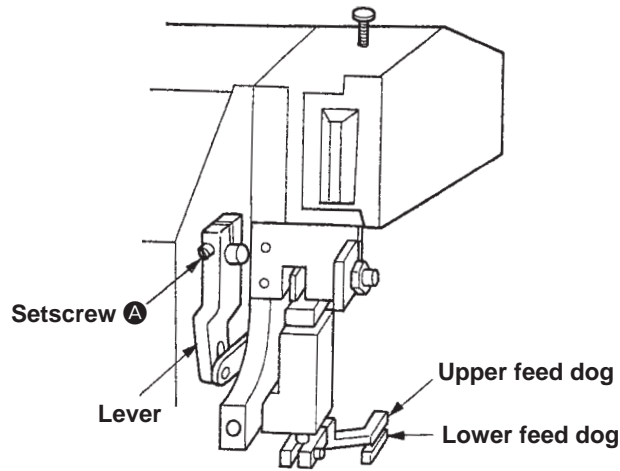

(14) Adjusting the presser foot

Standard Adjustment

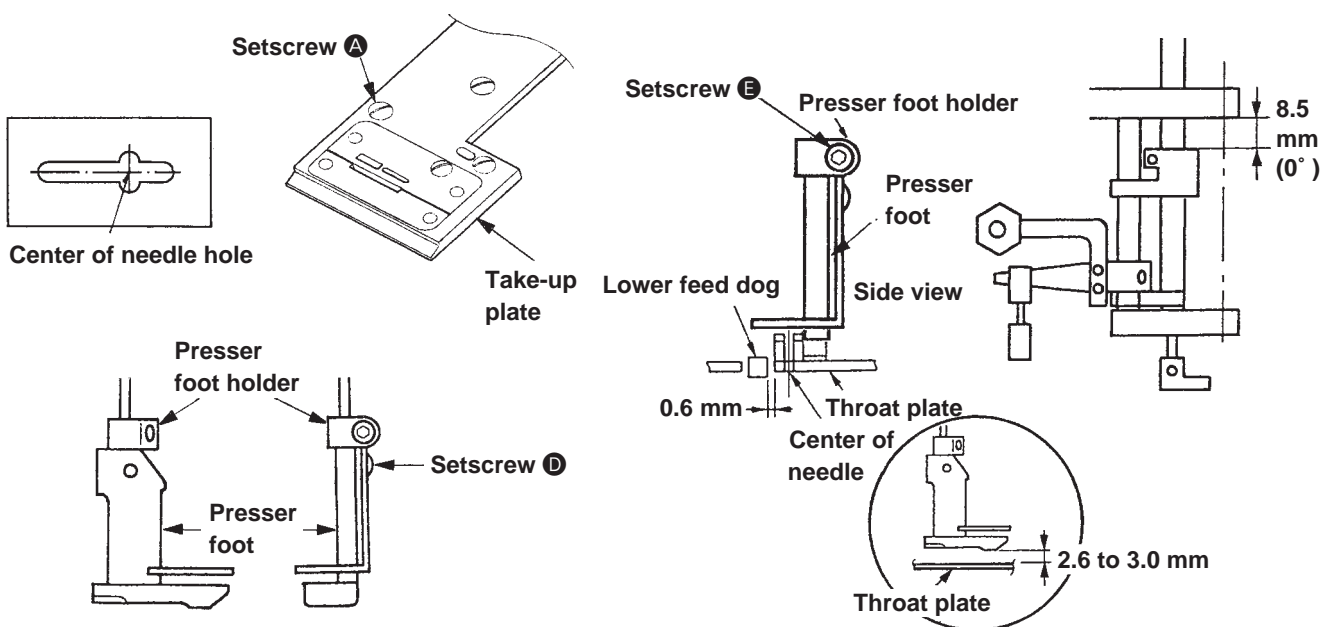

Adjustment Procedures	Results of Improper Adjustment
<p>1) Turn ON the power to the machine.</p> <p>2) Maximize the two stitch length adjusting dials on the control panel.</p> <p>3) Loosen setscrew A to set the lever free. Then adjust so that the upper feed dog meets the lower feed dog by moving the upper feed dog back and forth. After the adjustment, tighten setscrew A.</p> <p>The feed mechanism is controlled by a stepping motor, which means that the feed components cannot be positioned correctly unless the power to the machine is turned ON.</p>	<p>○ If the adjustment is not proper, the stitch length will be unstable.</p>

Adjustment Procedures	Results of Improper Adjustment
<p>1) To adjust the center of the needle with respect to the throat plate, loosen four setscrews A in the take-up plate first. Then position the throat plate so that the needle enters the center of the needle hole in the throat plate. Then tighten setscrews A in the take-up plate.</p> <p>2) Loosen setscrew E in the presser foot holder, and adjust so that the needle groove in the throat plate is aligned with the slot in the presser foot. After the adjustment, tighten setscrew E.</p> <p>3) Loosen setscrew D, and adjust the relation between the throat plate and the lower feed dog so that a 0.6 ± 0.1 mm clearance, on the needle center side, is provided between the throat plate and the lower feed dog. (Refer to the item (12) Adjusting the lower feed.)</p> <p>4) Loosen setscrew D, and you can move the presser foot back and forth. Now, align the presser foot with the center of the needle by moving the presser foot so that the groove in the presser foot is aligned with the center of the needle.</p>	

(15) Adjusting the upper feed eccentric shaft

Standard Adjustment

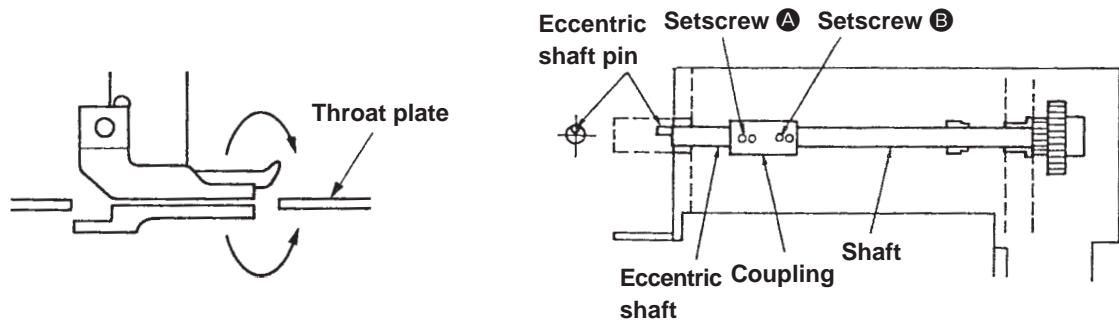

(16) Adjusting the left looper

Standard Adjustment

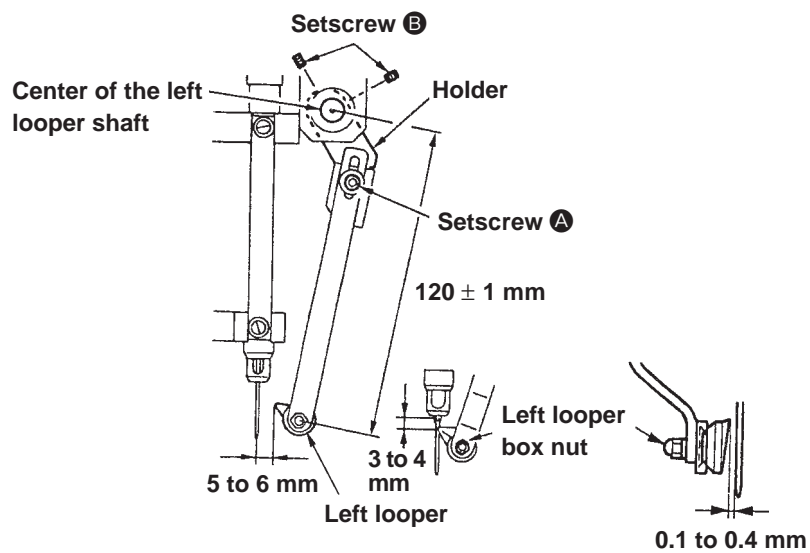

Adjustment Procedures	Results of Improper Adjustment
<p>1) Loosen setscrew B. Make the ascending lower feed dog flush with the throat plate surface by turning the handle.</p> <p>2) Make the descending upper feed dog engage with the lower feed dog by turning the coupling to move the eccentric shaft. Then tighten setscrew B.</p> <p>(Caution) Never loosen setscrew A.</p>	<ul style="list-style-type: none"> ○ Loosen the screw from underside of the upper frame. When the time is too early The material will shift to the left. ○ When the timing is too late : When the feed completes feeding the material and the upper feed and lower feed dogs are moving away from each other, the presser foot comes down together with the lower feed dog.

Adjustment Procedures	Results of Improper Adjustment
<p>1) Turn the handle until the left looper is brought to the forward end position toward you. (250° to 255°)</p> <p>2) Loosen setscrews B, and adjust so that a distance of 5 to 6 mm is provided between the center of the needle and the left looper and that a clearance of 0.1 to 0.4 mm is obtained between the needle and the left looper. After the adjustment, tighten setscrews B.</p> <p>3) Loosen setscrew A, and adjust so that a height difference of 3 to 4 mm is provided between the top end of the left looper and the needle eyelet when the top end of the looper is aligned with the center of the needle. After the adjustment, tighten setscrew A.</p>	<ul style="list-style-type: none"> ○ If the timing is too early, the left looper fails to scoop a loop.

(17) Adjusting the right looper cam

Standard Adjustment

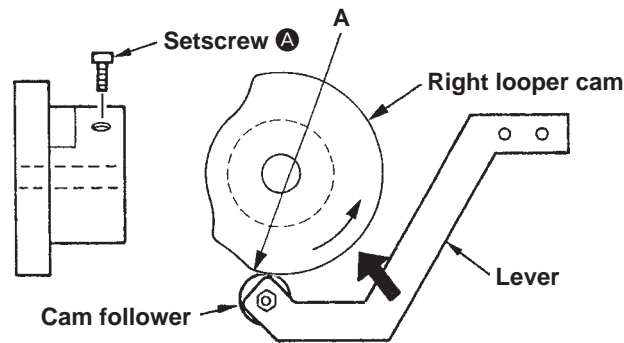

(18) Adjusting the right looper

Standard Adjustment

1) Adjusting the right looper pin

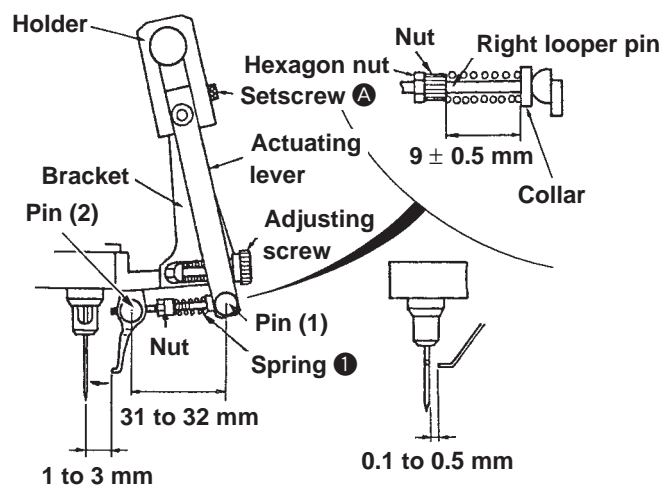

Adjustment Procedures	Results of Improper Adjustment
<p>1) Turn the handle until the arrow mark indicates 235°.</p> <p>2) Adjust so that the cam is set at position A where the cam follower starts coming down. Then tighten setscrew A.</p> <p>The position where the cam follower starts coming down is the position where the right looper starts scooping a loop from this side.</p> <p>* When the right looper returns to this side, check that the right looper does not come in contact with the support sleeve.</p> <div data-bbox="331 689 625 922" style="text-align: center;"> </div>	<ul style="list-style-type: none"> ○ If the timing is too early, the thread becomes tense. If the timing is too late, the right looper cam comes in contact with the support sleeve.

Adjustment Procedures	Results of Improper Adjustment
<p>1) Turn the right looper pin and adjust so that a distance of 31 to 32 mm is obtained between the center of pin (1) and the center of pin (2).</p> <p>Adjust the timing of the right looper to scoop a loop so that the top end of the left looper is aligned with the top end of the right looper at the center of the needle.</p> <p>2) Loosen hexagon nut, and adjust the installing length of right looper pin spring 1 so that a distance of 9 mm ± 0.5 mm is provided between the nut and the collar by turning the nut. After the adjustment, tighten the hexagon nut.</p> <p>Give the handle several turns and check that the right looper does not come in contact with the needle bar. If the looper comes in contact with the needle bar, re-adjust the position of the right looper.</p>	

Standard Adjustment

2) Adjusting the relationship between the right looper and the needle

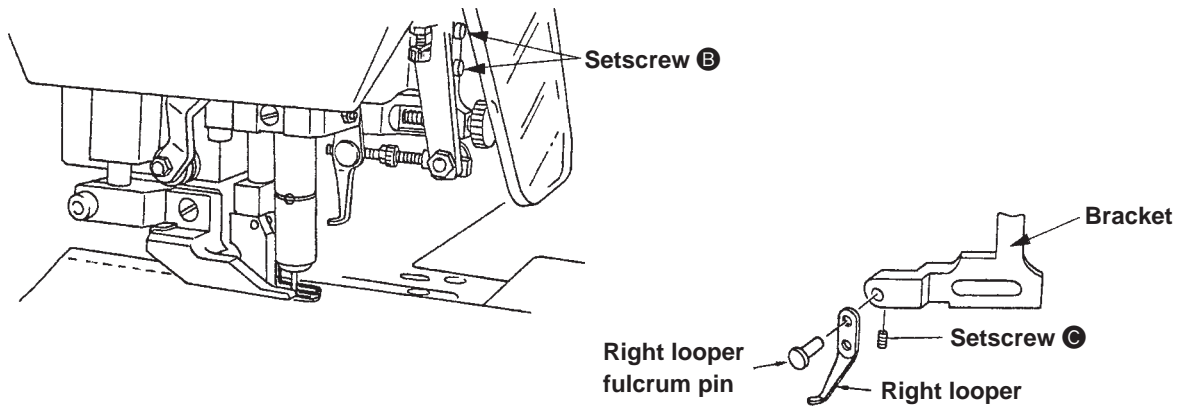

(19) Adjusting the position of the ellipse gear

Standard Adjustment

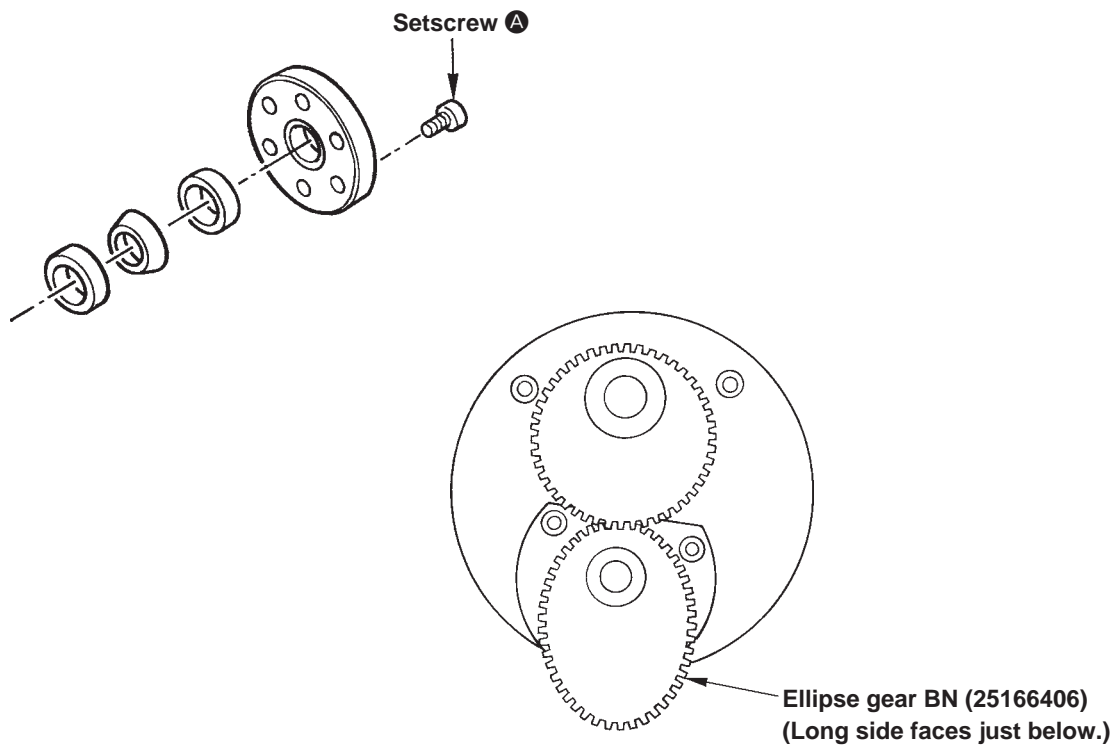

Adjustment Procedures	Results of Improper Adjustment
<ol style="list-style-type: none"> 1) To adjust the distance from the right looper to the needle, turn the handle until the left looper is brought to the forward end position toward the operator. Loosen setscrew A (previous item 1)) in the holder, and adjust so that a distance of 1 to 3 mm is provided between the needle and the top end of the right looper. After the adjustment, tighten setscrew A (previous item 1)). 2) Loosen setscrews B, and adjust so that a clearance of 0.1 to 0.5 mm is provided between the right looper and the needle. After the adjustment, tighten setscrews B. 3) Assemble the right looper and the bracket to allow the right looper to smoothly move when pressing the right looper fulcrum pin. Then tighten setscrew C. 	

Adjustment Procedures	Results of Improper Adjustment
<ol style="list-style-type: none"> 1) Loosen six setscrews A in the power lock connecting the ellipse gear shaft and the gear. 2) Adjust the scale of handle to 130°. 3) At this time, turn the gear by hand so that the long diameter side of ellipse gear BN faces just below as shown in the illustration . 4) When the gear is set to the position in the illustration, tighten six setscrews A in the power lock with 3.92N.m torque. 5) After completion of the aforementioned adjustment, perform (5 - (20)) Adjusting the lower looper. <p>(Caution) Perform checking of feed timing. (Check (12)-1) Adjusting the feed eccentric boss and the lifting cam.)</p>	

(20) Adjusting the lower looper

Standard Adjustment

1) Adjusting the lower looper arm

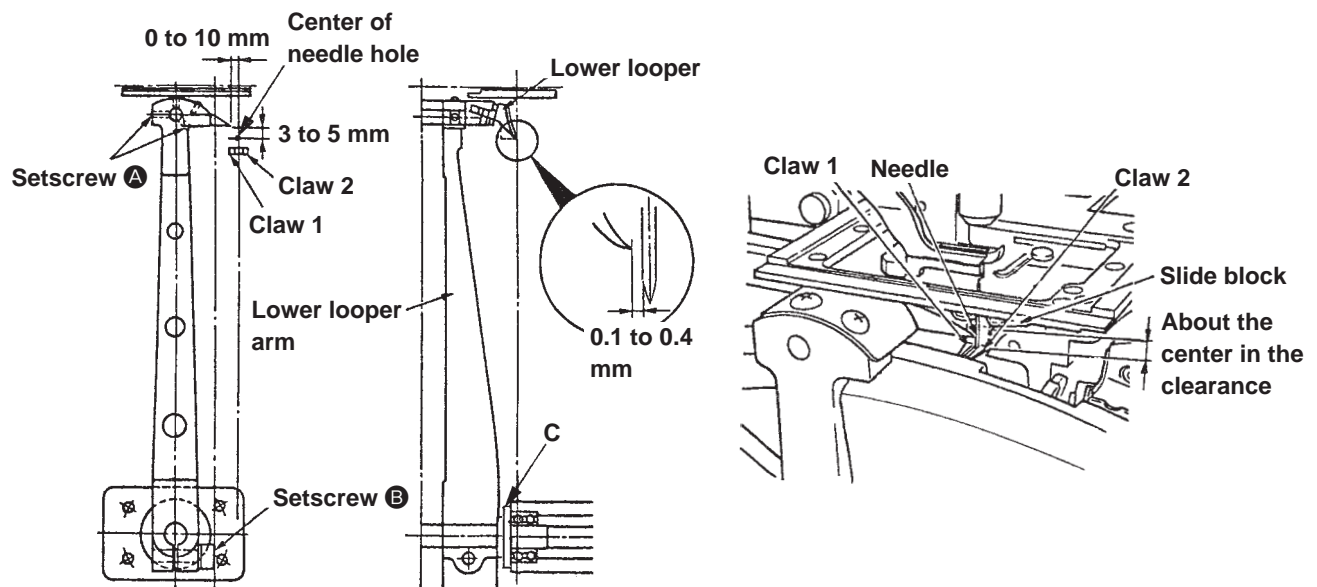

2) Disassembling and assembling the lower looper

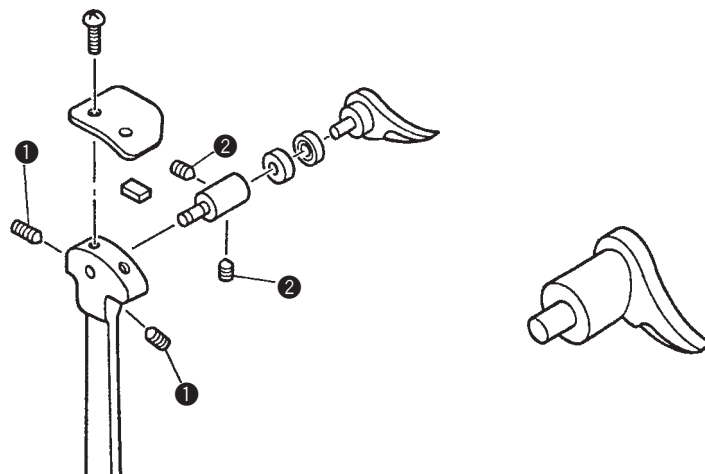

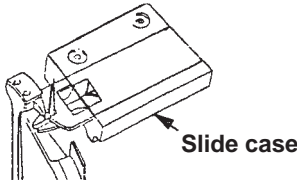
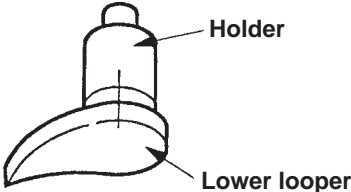
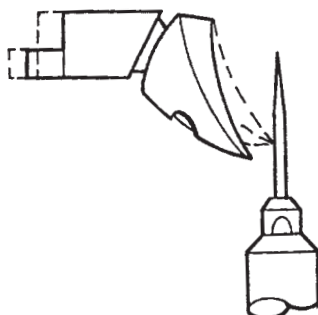
Adjustment Procedures	Results of Improper Adjustment
<p>1) Adjusting the height of the lower looper from the needle, and the clearance between them</p> <p>① Align the top end of the lower looper with the center of the needle.</p> <p>② Loosen setscrews B, and by moving the lower looper arm adjust so that the clearance between the lower looper and the needle is 0.1 to 0.4 mm. After fixing the thrust collar C by pressing it to the lower looper arm, tighten setscrew B so that there is no clearance between the thrust collar and the lower looper arm.</p> <p>③ Loosen two setscrews A, and adjust the height difference between the top end of the lower looper and the center of the needle hole to 3 to 5 mm. Then tighten setscrews A. At this time (before tightening the screws), position the top end of the lower looper at about the center of the clearance between the slide block and the top face of the claw end. Turn the handle, give the lower looper arm one turn, and check that the top end of lower looper does not touch the periphery of the drum. Then tighten setscrews A.</p> <p>The position of 83 to 85° is the position where the needle guide claws completely close. Consequently, check that the needle guide claws are closed when the top end of the lower looper is aligned with the center of the needle.</p> <p>Adjust the top end of the lower looper in a state that the play in the lower looper arm is moved to backward.</p> <p>2) Adjusting the lower looper and the needle</p> <p>Turn the handle until the angle board indicates 83 to 85°.</p> <p>Loosen arm setscrews B, and adjust so that the distance from the top end of the lower looper to the center of the needle is 0 to 10 mm. Then tighten setscrews B.</p>	<p>○ If the adjustment is not proper, a mistake of lower looper thread scooping will occur, causing thread breakage.</p>  <p style="text-align: right;">Slide case</p>
<p>1) Loosen setscrew 1, and draw out the holder.</p> <p>2) Before loosening setscrews 2, attach a mark on the holder and the lower looper. Then disassemble them.</p>  <p>3) Remove the roller and the bearing mounted on the lower looper, and remove thread waste, etc. from them.</p> <p>4) When assembling, follow the aforementioned procedure 1) through 3) for disassembling the lower looper in the reverse order.</p> <p>Relation of the lower looper and the needle should be the same as that in the previous item 1).</p> <p>* After the assembling and adjustment, turn the handle by hand, and check that the lower looper does not come in contact with other components.</p>	<p>○ Provide a slightly larger distance between the looper and the center of the needle.</p> <p>○ The distance provided between the looper and the center of the needle depends on the position of the eccentric of the holder.</p> 

(21) Adjusting the command block and the proximity sensor

Standard Adjustment

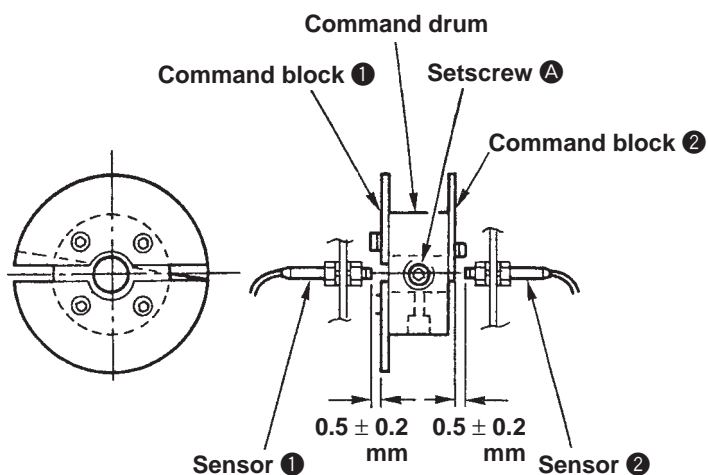

(22) Adjusting the feed, reverse stitching position, and the proximity sensors

Standard Adjustment

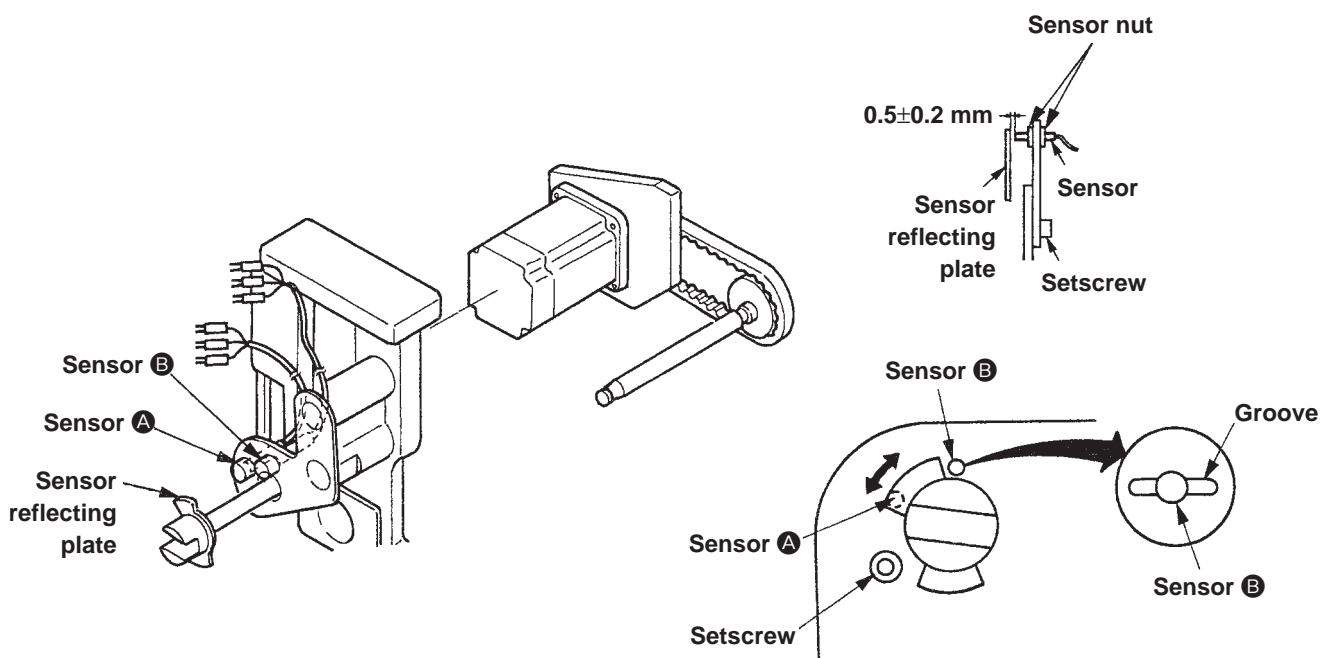

Adjustment Procedures	Results of Improper Adjustment
<p>1) Bring the machine to its home position (0°).</p> <p>2) Loosen two setscrews A of the command drum.</p> <p>3) At this time, release sensor 1 from command block 1 and let sensor 2 enter command block 2. Then tighten setscrews A.</p> <p>4) The clearance between each sensor and each block should be 0.5 ± 0.2 mm.</p> <p>Sensor 1 Feed change-over timing sensor When sensor 1 moves away from the command block, the operative feed changes over between the top feed and the bottom feed.</p> <p>Sensor 2 Feed start sensor This is the sensor to detect the stitch length on the right side or the wrong side of the material.</p>	<p>○ If the clearance is not correct, the sensor does not detect correctly, causing defective feed.</p>

Adjustment Procedures	Results of Improper Adjustment
<p>1) Adjusting the clearance between the sensor and the sensor reflecting plate Adjust with the sensor nut so that a clearance of 0.5 ± 0.2 mm should be provided between each top end of sensors A and B and the sensor reflecting plate.</p> <p>2) Adjusting the position of sensor B (reverse stitching sensor) Stitch length of the reverse stitching depends on the position of sensor B. Loosen the sensor nut, move sensor B inside the groove, and fix it at the position where the stitch length for reverse stitching becomes 1 to 3 mm. At this time, be careful not to change the clearance between the sensor and the reflecting plate.</p>	

(23) Adjusting the needle stopping position

Standard Adjustment

Upper stopping position

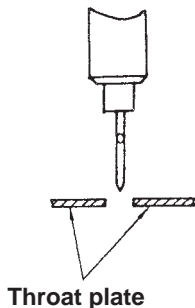

Intermediate lower stopping position

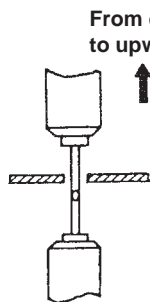

Intermediate upper stopping position

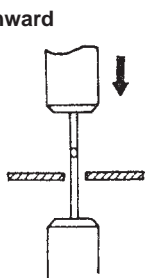

From downward to upward

FLS-350N

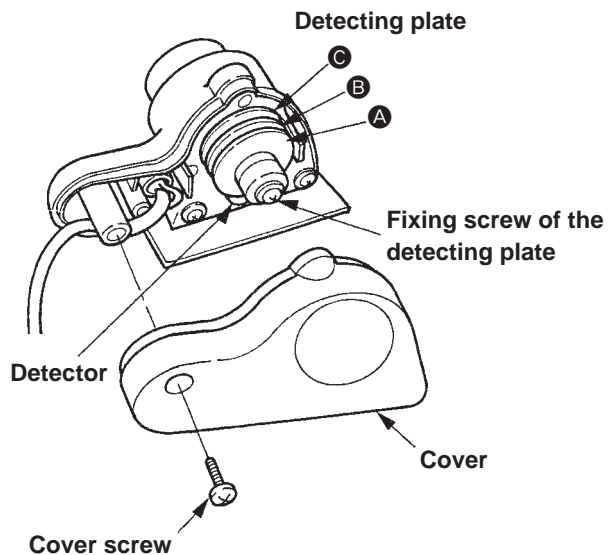

FLS-350NA • NB
FLS-351NA

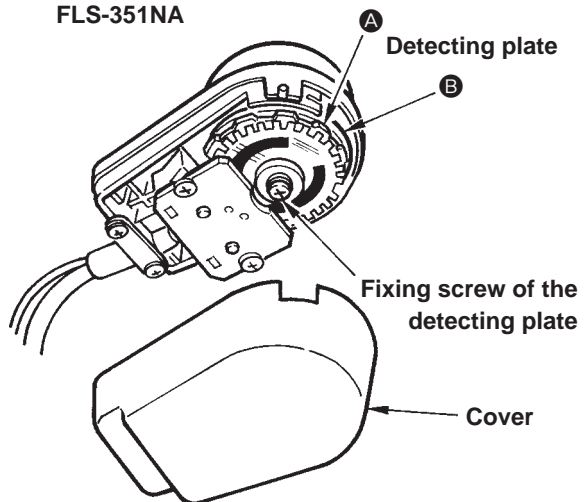

Adjustment Procedures	Results of Improper Adjustment
<p>In case of FLS-350N :</p> <ol style="list-style-type: none"> 1) Loosen the cover screw and remove the cover. 2) Slightly loosen the fixing screw of the detecting plate. 3) Bring the machine to its home position (0°), and adjust the upper needle stopping position by aligning the slit of detecting plate A with the detector. 4) Adjust the intermediate upper stopping position of the needle by aligning the slit of detecting plate B with the detector so that the angle board points $30^{\circ} \pm 2^{\circ}$. 5) When adjusting the intermediate lower stopping position of the needle, stop the machine at the angle of $210^{\circ} \pm 2^{\circ}$. Then align the slit of detecting plate C with the detector. 6) Tighten the fixing screw of the detecting plate. 7) Turn ON the power switch and operate the foot pedal to check the respective stopping positions of the needle. 8) Install the cover. <p>In case of FLS-350NA • NB and FLS-351NA :</p> <ol style="list-style-type: none"> 1) Loosen the cover screw and remove the cover. 2) Slightly loosen the fixing screw of the detecting plate. 3) Bring the machine to its home position (0°), and adjust the upper needle stopping position by aligning the slit of of detecting plate B (black color) with the detector. 4) Adjust the intermediate upper stopping position of the needle by aligning the slit of detecting plate A (red color) with the detector so that the angle board points $30^{\circ} \pm 2^{\circ}$. 5) Adjustment of the intermediate lower stopping position of the needle has been set with SC-380 so that the machine stops at the angle of 210°. 6) Tighten the fixing screw of the detecting plate. 7) Turn ON the power switch and operate the foot pedal to check the respective stopping positions of the needle. 8) Install the cover. 	<ul style="list-style-type: none"> ○ If the stopping position of the needle shifts, causing defective stitches or needle breakage.

(24) Adjusting the tension of the timing belt of the feed stepping motor

Standard Adjustment

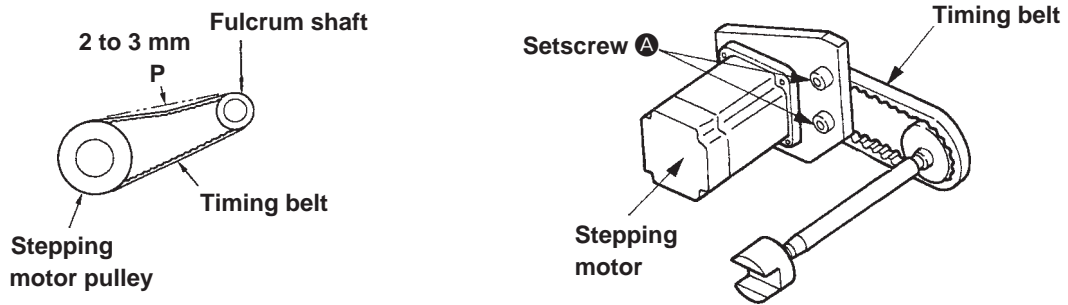

(25) Adjusting the threader needle during replacement

Standard Adjustment

FLS-350N

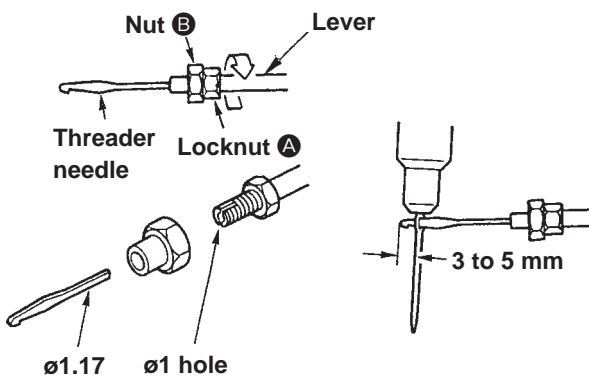

**FLS-350NA • NB
FLS-351NA**

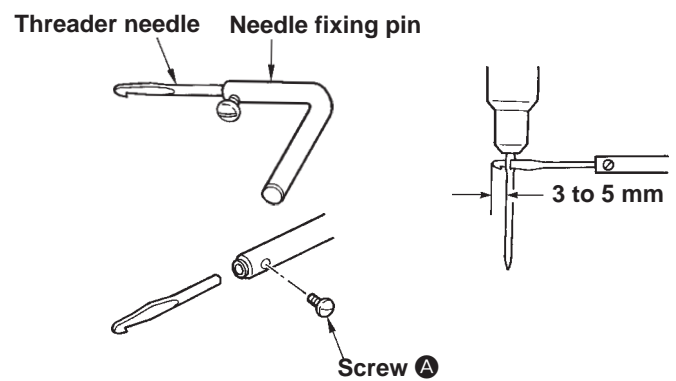

Adjustment Procedures	Results of Improper Adjustment
<p>Loosen setscrews A, and adjust the tension of the timing belt so that the belt slackens by 2 to 3 mm when 300g of tension are applied on the belt in direction P.</p>	<ul style="list-style-type: none"> ○ If the timing belt of the stepping motor is not sufficiently tensed, the stitch length may be inconsistent. On the other hand, if the timing belt is excessively tensed, an excessive load may occur on the feed shaft unit. So adjust the tension applied to the timing belt so that the fulcrum shaft of the pulley (small) can be smoothly turned by hand.

Adjustment Procedures	Results of Improper Adjustment
<p>In case of FLS-350N : Loosen locknut A. Remove nut B and pull out the threader needle. When attaching the threader needle, install it so that it protrudes from the needle eyelet by 3 to 5 mm when inserted through the needle eyelet. Then tighten locknuts A and B.</p> <p>In case of FLS-350NA • NB and FLS-351NA : Loosen screw A and pull out the threader needle. When attaching the threader needle, install it so that it protrudes from the needle eyelet by 3 to 5 mm when inserted through the needle eyelet. Then tighten screw A.</p>	

(26) Adjusting the angle of the foot pedal, and the foot pressure of the pedal (FLS-350N only)

Standard Adjustment

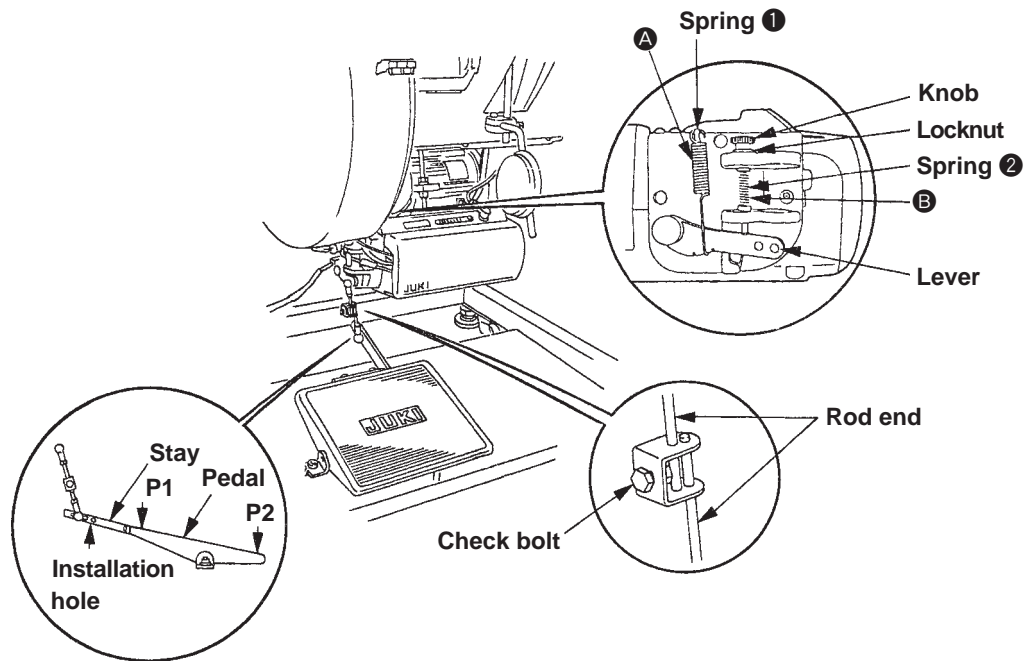

(27) Servomotor controller box connection diagram

Standard Adjustment

FLS-350N

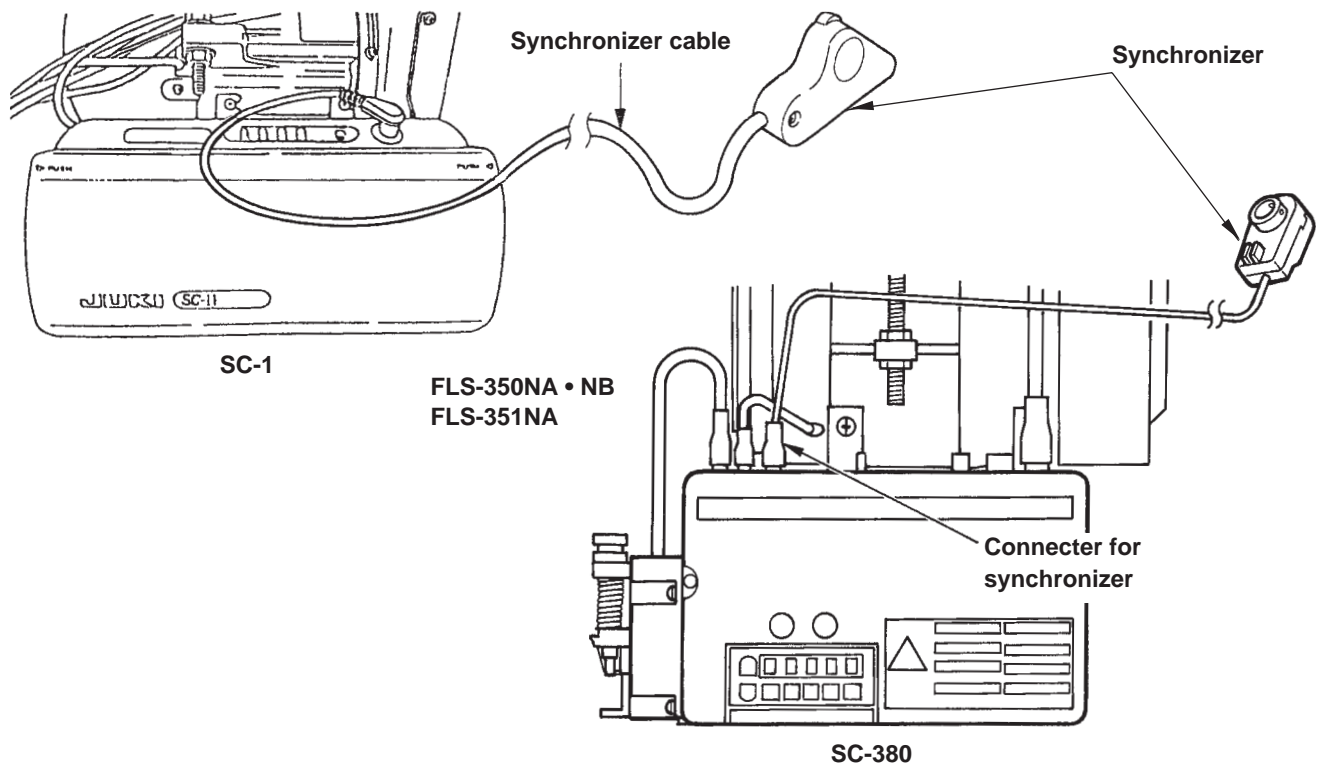

Adjustment Procedures	Results of Improper Adjustment
<p>1) Loosen the check bolt, and adjust the angle of the foot pedal by changing the attaching length of the rod end or installation hole of the stay to be used.</p> <p>2) Adjust the foot pressure of the pedal following the procedure described below.</p> <p>① Adjusting the pressure to be applied to the front part of the foot pedal Adjust the pressure at position P1 to 2 to 4 kg by changing the position to which the lever spring of spring ① at section A is hooked.</p> <p>② Adjusting the pressure to be applied to the rear part of the foot pedal Turn the knob to loosen the locknut, and adjust spring ② at section B so that a pressure of 7 to 10 kg is applied to position P2. After the adjustment, be sure to tighten the locknut.</p>	

Adjustment Procedures	Results of Improper Adjustment
<p>Connect the detector (synchronizer).</p>	

(28) Disassembling/assembling the needle bar

Standard Adjustment

The period for disassembling and cleaning of the needle bar depends on the operation frequency, however, be sure to disassemble and clean the needle bar components once a week. If dust accumulates in the needle bar components, troubles in sewing may result. Be sure to perform disassembling and cleaning earlier to prevent the troubles from occurring.

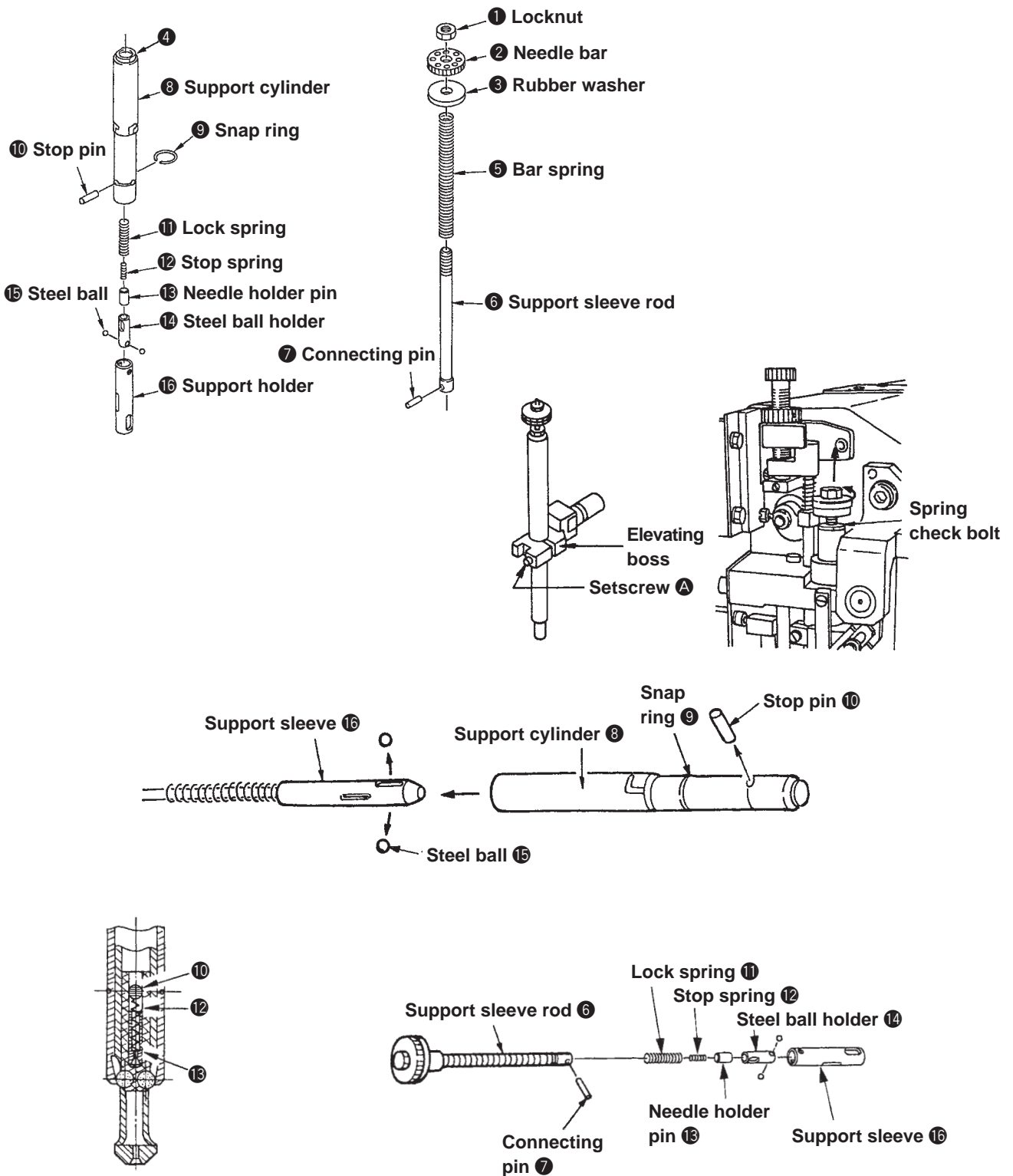

Adjustment Procedures	Results of Improper Adjustment
<p>Disassemble/assemble the needle bar components following the procedure described below.</p> <p>The procedure is common to the upper needle bar and the lower needle bar.</p> <ol style="list-style-type: none"> 1) Slightly loosen check bolt ④ of the spring first with the needle bar attached in place. 2) Turn the handle until the screw in the elevating boss appears before you. Now, loosen setscrew ①, and remove the needle bar from the main unit of the sewing machine. 3) Completely loosen check bolt ④ of the spring, and remove the snap ring. (Refer to the item (29) "Removing the snap ring when disassembling the needle bar") 4) Draw out stop pin ⑩ from support cylinder ⑧. 5) Detach support sleeve ⑯ from support cylinder ⑧. <p>(Caution) At this time, be careful not to lose two steel balls ⑮.</p> <ol style="list-style-type: none"> 6) Push connecting pin ⑦ out from support sleeve ⑯. 7) Detach lock spring ⑪ and steel ball holder ⑭ from support sleeve ⑯. 8) Remove needle holder pin ⑬ and stop spring ⑫ from steel ball holder ⑭. 9) Inspect and clean the components. <p>(Inspection items)</p> <ol style="list-style-type: none"> ① If stop spring ⑫ has broken or its inside part has been clogged with dust or has broken, replace stop ring ⑫ with a new one. ② If the top end of needle holder pin ⑬ has broken or inside hole has been clogged with dust and has been damaged, replace the pin. If the hole has been clogged with dust, clean the pin. ③ Clean the inside of support sleeve ⑯ and support cylinder ⑧. <ol style="list-style-type: none"> 10) Assemble the needle bar components by reversing the above procedure from step 8) to step 1). <p>(Caution) When assembling the needle bar, be careful to position needle holder pin ⑬ and stop spring ⑫ as illustrated when inserting stop pin ⑩ in place.</p>	

(29) Removing the snap ring when disassembling the needle bar

Standard Adjustment

①

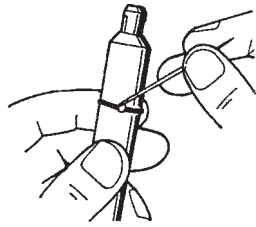

②

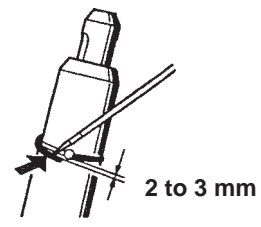

③

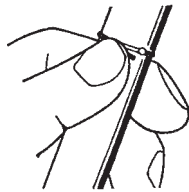

④

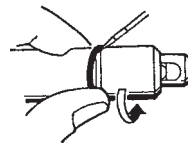

⑤



Adjustment Procedures	Results of Improper Adjustment
<ol style="list-style-type: none"> 1) Hold the needle bar as shown in ①. At this time, be sure to place your index finger on the back of the snap ring. 2) Using a needle, slightly take out either end of the snap ring from the groove. At this time, the lift amount of the end of the snap ring should be approximately 2 to 3 mm as shown in ②. 3) Press the end (arrow mark section) of the snap ring taken out from the groove with your thumb, and release your index finger from the back of the snap ring. 4) Pressing the end of the snap ring with your thumb, slowly turn the needle bar, and gradually remove the snap ring from the groove using the tip of a needle. 5) Place the snap ring removed from the groove around the needle bar as shown in ⑤. <p>Provided that the snap ring is removed in accordance with the above-mentioned procedures, there will be no excessive tension on the snap ring. There will therefore be no decrease in the spring of the snap ring.</p> <p>(Caution) If the snap ring is fitted in the groove in the needle bar, replace the ring if it comes out of the groove or a play is excessive.</p>	<ul style="list-style-type: none"> ○ If the snap ring is widened and protrudes from the needle bar, machine lock during sewing will occur.

6. ELECTRICAL COMPONENTS

- (Caution) 1. When installing or removing a printed circuit board, be sure to turn the power OFF first.
 2. Do not touch the connectors of a printed circuit board.

(1) Printed circuit boards in the control box

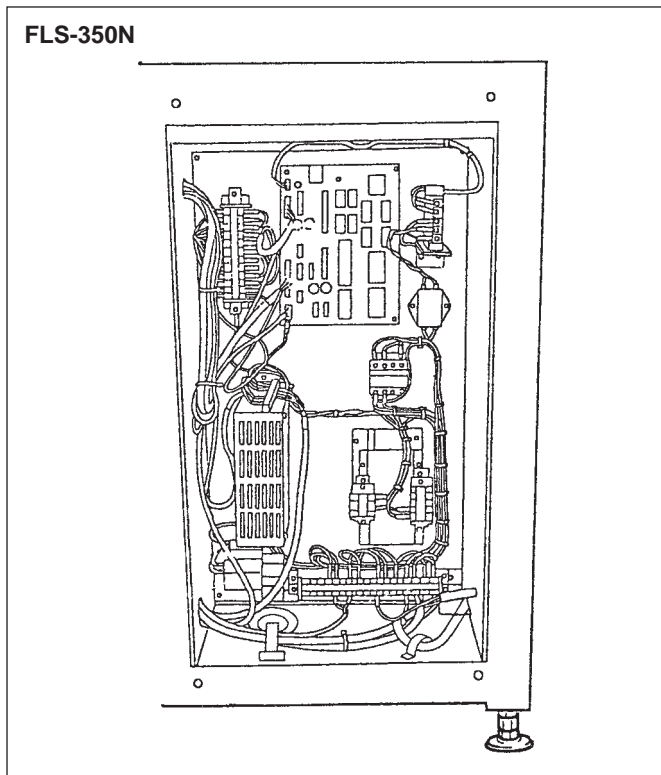

- ① Lights up when proximity switch NS-1 (feed start sensor) is ON..... CR 1
- ② Lights up when proximity switch NS-2 (feed change-over timing sensor) is ON. CR 2
- ③ Lights up when proximity switch NS-3 (feed origin retrieval sensor) is ON. CR 3
- ④ Lights up when proximity switch NS-4 (reverse stitching sensor) is ON. CR 4
- ⑤ Lights up while reverse stitching command switch PB-2 is ON. CR 5
- ⑥ Lights up when stitch change-over switch PB-1 is ON. CR 6
- ⑦ Max. stitch length setting variable resistor VR1
 The range of the maximum stitch length adjusted by the max. stitch length setting variable resistor is 8 ± 0.3 mm.
 Adjust the variable resistor within the specified range.
- ⑧ Min. stitch length setting variable resistor VR2
 The range of the minimum stitch length adjusted by the min. stitch length setting variable resistor is $0.6^{+0.3}_{-0.1}$ mm.
 Adjust the variable resistor within the specified range.
 Turn the respective stitch length setting variable resistors clockwise to maximize the max. or min. stitch length, or counterclockwise to minimize it.
- ⑨ Max. rotating speed setting variable resistor VR3
- ⑩ Min. rotating speed setting variable resistor VR4
 Turn the respective rotating speed setting variable resistors clockwise to minimize the max. or min. rotating speed, or counterclockwise to maximize it.

(Caution) The variable resistors have already been factory-adjusted at the time of delivery, so do not adjust them unless absolutely necessary.

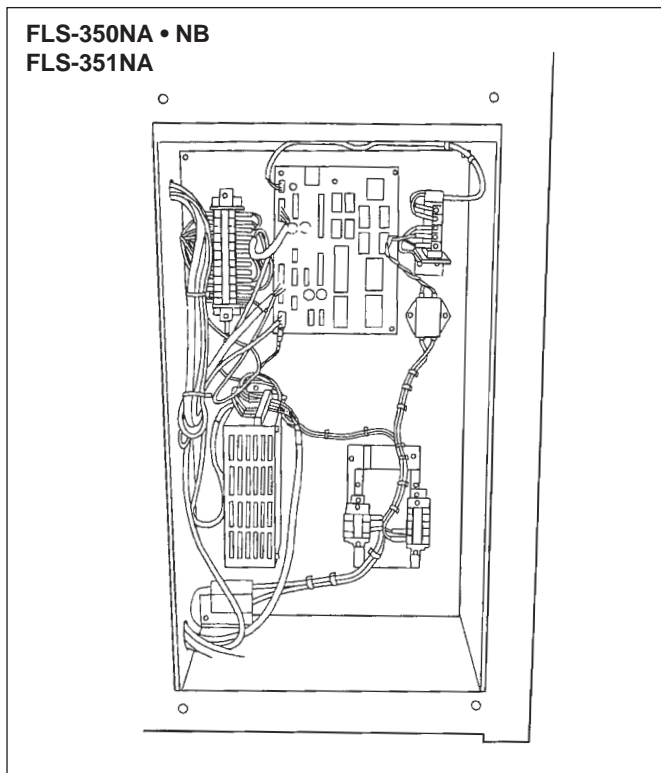

7. MAINTENANCE AND INSPECTION

- Be sure to carry out the following maintenance and inspection procedures at regular intervals in order to keep the machine in best condition at all times.
- Failure to carry out maintenance and inspection may cause the machine to malfunction.

(1) Electrical components

- Once a month, check all the connectors for loose contact caused by mechanical vibration or some other reason.

(2) Mechanical components

- Lubricate the moving and sliding parts of the machine. (Refer to the next page.)
- Disassemble the needle bar, wipe away any dust, and grease the needle bar assembly once a week. (Refer to the item (29).)
- Grease each gear, cam and cam groove once every six months. (Refer to the next page.)
- Periodically check the belt tension.

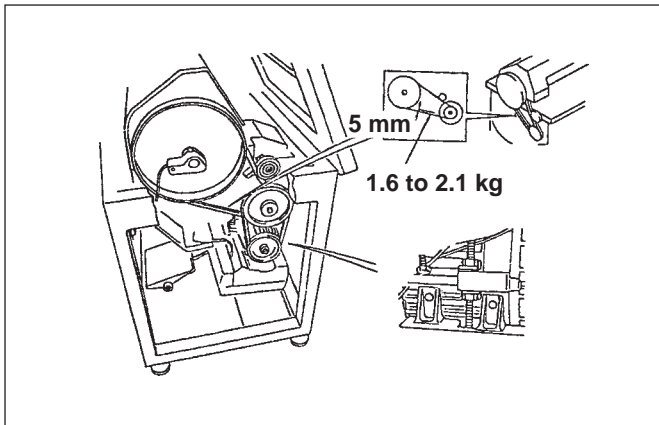

Using the tension roller, adjust the belt tension so that the center of the belt slackens by about 5 mm when a 1.6 to 2.1 kg load is applied.

(Caution) Be careful not to allow any oil to drop or splash onto the belt.

If the machine runs with the belt loosened, excessive slippage may occur resulting in the machine malfunctioning. To avoid this, be sure to carry out periodical maintenance and inspection.

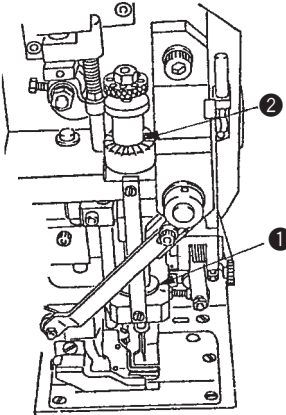
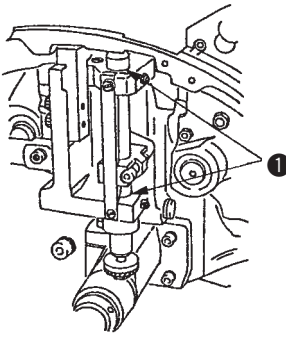
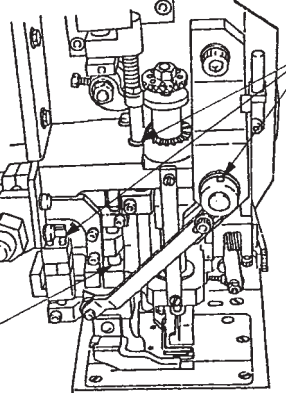
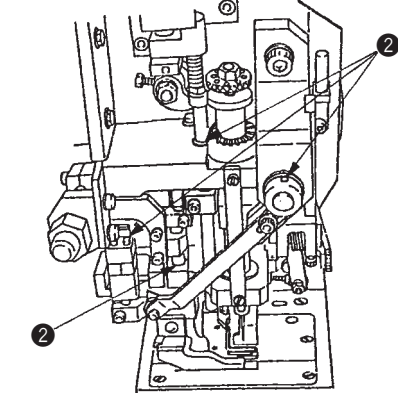
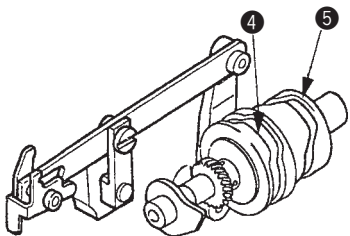
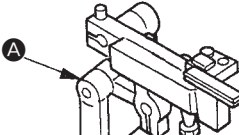
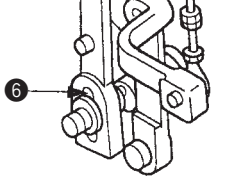
Period		
Everyday	JUKI New Defrix Oil No. 2	Bearings ① of upper and lower needle bars 
Once a week	JUKI New Defrix Oil No. 2	Upper feed link ② 
Once a week	JUKI New Defrix Oil No. 2	Feed drive link ① 
Every six months	Grease	Ellipse gear Other gears 
Every six months	Grease	Tubular roller cam ④ of the needle guide claw 
Every six months	Grease	Tubular roller cam ⑤ of the thread haul lever 
Every six months	Grease	Feed eccentric boss ⑥ 

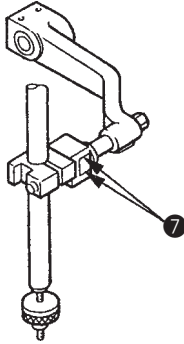
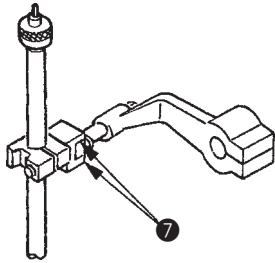
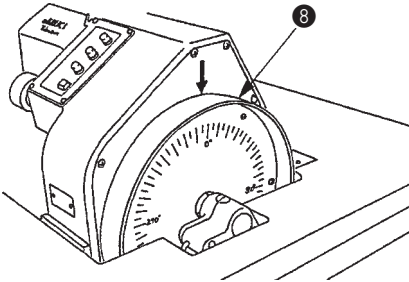
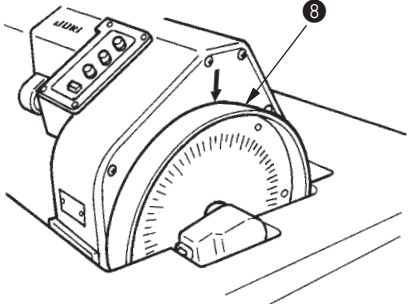
Period		
Every six months	Grease	<p>Slide blocks ⑦ of elevating bosses of the upper and lower needle bars</p>  <p>(Lower needle bar)</p>  <p>(Upper needle bar)</p>
Every six months	Grease	<p>Groove cam wheel ⑧ Grease the whole surface of the internal groove.</p>  

(3) Consumable parts replacing period table

- The needle bar contains the following consumable parts.

The following table indicates the time to replace these parts. So periodically replace the respective consumable parts referring to the table below.

Expendable part	Time for replacement	Description	Trouble
1. Stop spring (25217704)	3 to 6 months	In addition to the regular time for replacement, replace them if it breaks when disassembling the needle bar.	Needle breakage
2. Snap ring (G5513340000)	2 to 6 months	It is recommended to replace the snap ring earlier than the designated time for replacement. If any gap is found when fitting the snap ring in the groove on the needle bar support cylinder or the snap ring is damaged, has burrs or has worn out, replace the snap ring with a new one.	Needle bar is pushed against the bearing. Needle bar shifts out of position.
3. Needle holder pin (FLS-350N : 25250002 FLS-350NA • NB : 25250010 FLS-351NA : 25234105)	0.5 to 1.5 years	If the top end of the needle holder pin becomes chipped, replace it with a new one. If the inside diameter section of the needle holder pin is clogged with dust, remove the dust with a drill supplied with the unit.	Blunt needle tip Needle breakage
4. Rubber washer (16661704)	0.8 to 1.5 years	The rubber washer cracks circularly. Replace the rubber washer with a new one before it totally breaks. If the rubber washer has become flat, adjust the timing of the needle bar.	Needle breakage
5. Thread guide brush (25240102)	0.5 to 1.5 years	If the rubber washer is crushed, adjust the needle bar timing. If the brush bristles have worn out and come off, replace the brush with a new one.	Thread breakage

8. ERROR CODES

If any error is detected while the machine is in operation, the detector buzzer sounds and the corresponding error code is given on the display panel. Even when the error code is given, however, there is a case that the error is simply caused by the disconnection of connector. Be sure to check the error according to the following table.

Error code	Probable cause	Inspection
	8A fuse in control box broken. Is the power voltage too low? Is the power supply capacity too small? Note : It does this display when power supply is turned OFF, but this is not an error.	Replace the 8A fuse. Check the power voltage. Check the power supply capacity.
E 1	Is the wire to the motor short-circuited? Is the sewing machine load torque too high?	Check the motor wiring. Check the sewing machine.
E 2	Is the power voltage too high? Is the sewing machine inertia too high?	Check the power voltage. Lengthen the deceleration time.
E 3	Is the connector to the motor encoder securely inserted? Are the signals from the motor encoder correct? Is the sewing machine locked? Is the motor locked?	Check the connector insertion. Check the encoder signals. Check the sewing machine. Check the motor.
E 4	Is the motor connector (4-pin) securely inserted ? Are the signals from the motor connector (4-pin) correct ?	Check the motor connector insertion. Check the motor connector.
E 6	Is an extraordinary signal inputted? (The signal as it repeats ON/OFF at the high frequency.) Does the noise from outside enter an input signal.	Check the input signal. Removes a noise source.
E 8	Is the position detector connector securely inserted? Are the signals from the detector correct? (UP/DOWN signal interruption)	Check the detector connector insertion. Check the detector UP/DOWN signals.
E 9	Is the solenoid connection (thread trimming, presser foot lifter, etc.) short-circuited ? Is the solenoid wiring short-circuited ?	Check the solenoid wiring. Replace the solenoid.

9. TROUBLES AND CORRECTIVE MEASURES

(1) Mechanical components

Troubles	Cause (1)	Cause (2)	Corrective measures
1. Thread breakage	The lower looper has been threaded twice.		Adjust the thread path guide. [Refer to 5-(6).] Adjust the thread haul lever.
	The thread remains in the drum.		Check both the outside and inside of the drum, and wipe away any dust.
	The thread is entangled in the lower looper shaft and looper roller.		Adjust the thread path guide. [Refer to 5-(6).] Adjust the thread haul lever.
	The lower looper fails to catch the thread.		Adjust the lower looper. [Refer to 5-(20).]
	A scratch has appeared on the thread path.		Properly finish the guide metal fitting, throat plate, looper, drum, thread path guide, or other related parts.
	The hook finger fails to catch the thread.		Adjust the hook finger. [Refer to 5-(9), -(10), -(11).]
	2. Needle breakage	Faulty needle bar	The stop spring has broken.
		The tip of the needle holder pin is broken.	Replace the needle holder pin. [Refer to 5-(28).]
		Dust (thread waste) has accumulated on the needle bar.	Clean the needle bar. [Refer to 5-(28).]
		The hole in the needle guard pin is clogged with dust.	
		The rubber washer has broken.	Replace the rubber washer. [Refer to 5-(28).]
		The needle holder pin or stop spring cannot be installed in the predetermined position.	Re-adjust the installation position of the needle holder pin or stop spring. [Refer to 5-(28).]
		Faulty catching.	Adjust the height of the needle bar. [Refer to 5-(4).]
3. Wobbling or waving stitches are made.		The needle fluctuates to the left or right when it is delivered between the upper and the lower needle bars.	
	The needle is bent.		Replace the needle with a new one.

Troubles	Cause (1)	Cause (2)	Corrective measures
4. Stitch skipping	The feed mechanism fails to feed the material.		Adjust the min. stitch length fine adjustment variable resistor VR2 properly. [Refer to 6. Electrical components.]
5. The maximum stitch length cannot be made.			Adjust the max. stitch length fine adjustment variable resistor VR1 properly. [Refer to 6. Electrical components.]
6. Loose stitches	Isolated idle loops are made on the right side of the material.	The left looper fails to catch the thread.	Adjust the left looper.
	Isolated idle loops are made on the wrong side of the material.	Faulty timing of the hook finger	Adjust the hook finger.
	Excessive seam tension	Faulty claw chuck of the needle guide	Adjust the needle guide claw.
		The right looper fails to catch the thread.	Adjust the right looper. [Refer to 5-(18)]
		Scratch on the thread path	Buff the thread path.
7. Reverse stitching is invalid.	Defective switch		Replace the switch.
	Damaged power cable		Check the cable for breakage.
	The proximity sensor fails to work.		Adjust the proximity sensor.
8. Abnormal noise sounds.	Check the position where makes the noise.	Irregular noise sounds from the underside of the table.	Replace the snap ring of the needle bar.
		Noise sounds from the inside of the pulley or inside of the frame.	Apply grease to the gears and cams.

(2) Electrical components

Troubles	Cause (1)	Cause (2)	Corrective measures
1. The machine cannot be powered up even though the power switch has been turned ON.	1) The transformer is not connected properly.		Check the wiring.
	2) There is no power to the transformer.	Fuse F1 has blown.	Replace fuse F1.
		Fuse F2 has blown.	Replace fuse F2.
		The power cable has been damaged.	Replace the cable.
	3) The safety device of the drum cover is actuated.	The drum cover opens.	Close the drum cover.
4) Faulty contact of the power switch	Faulty contact of the limit switch	Check the cable.	
		Replace the switch.	
	5) The electromagnetic switch fails to work.	Fuse F3 has blown.	Replace fuse F3.
2. The sewing machine motor fails to rotate.	1) The connector in the control box is not properly connected.		Check whether the connector has been firmly connected.
	2) Defective detector		Replace the detector.
	3) The power is not turned ON.		Turn ON the power switch.
	4) The power cable has been disconnected.		Check the connection of the power cable.

Troubles	Cause (1)	Cause (2)	Corrective measures	
3. The stepping motor fails to run.	Faulty stepping motor driver		Replace the driver.	
	Faulty signal output from the control printed circuit board		Replace the control printed circuit board.	
	Faulty proximity sensor		Replace the proximity sensor.	
	Defective power cable	The connector has been disconnected.		Check the connector.
		The power cable has been damaged.		Replace the cable.
	The stepping motor driver cannot be actuated.			Check the power supply.
4. Change-over of the switch is invalid.	Faulty switch contact		Replace the switch.	
5. When moving your foot away from the pedal, the machine stops immediately without rotating until the home position is reached.	The belt between the main shaft and the intermediate shaft excessively slacks. (Synchronizer error)		Adjust the belt tension, and turn OFF the power to the machine once. Or replace the belt.	

10. TIME CHART

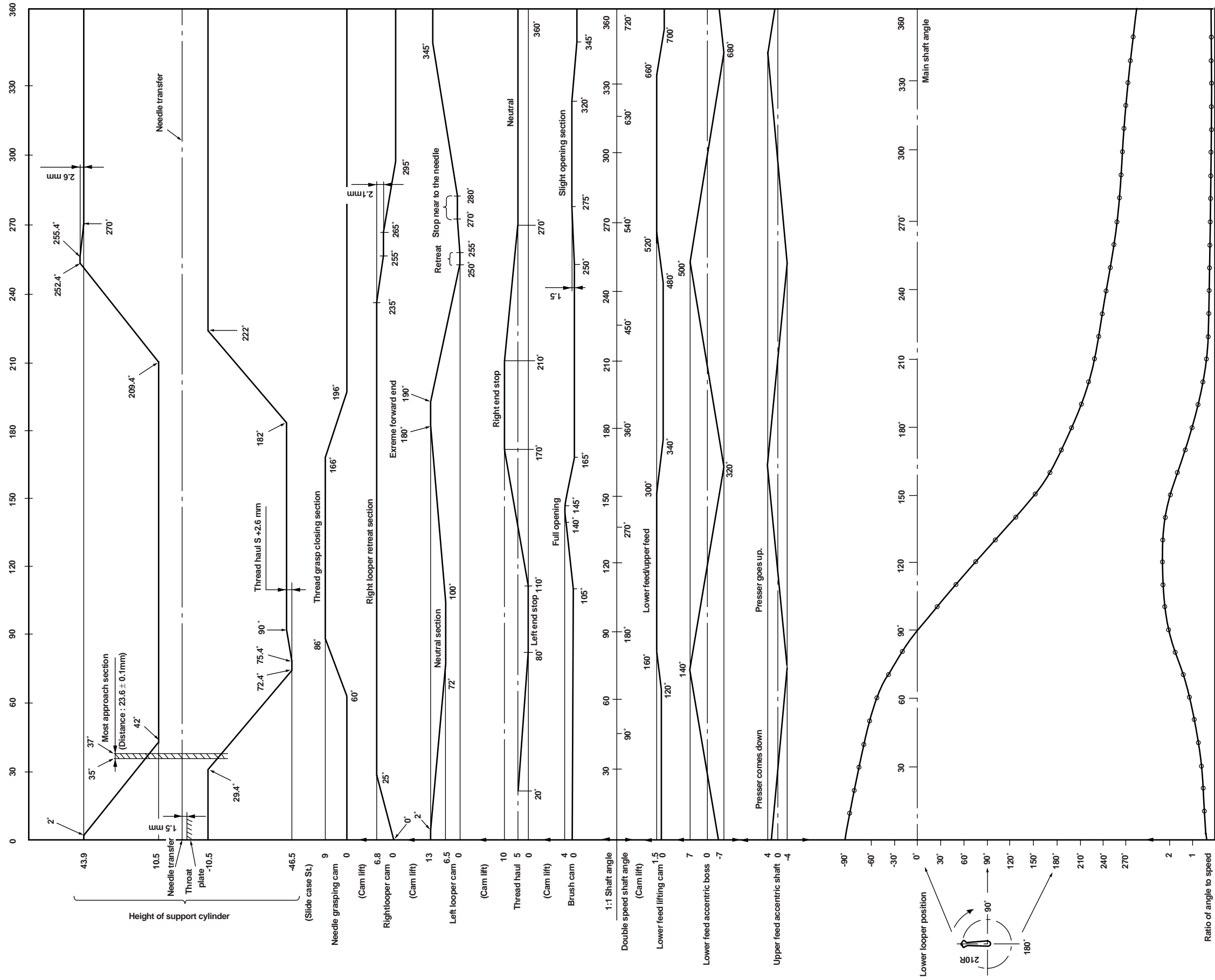

11. CIRCUIT DIAGRAM

(1) Layout drawing of the control box

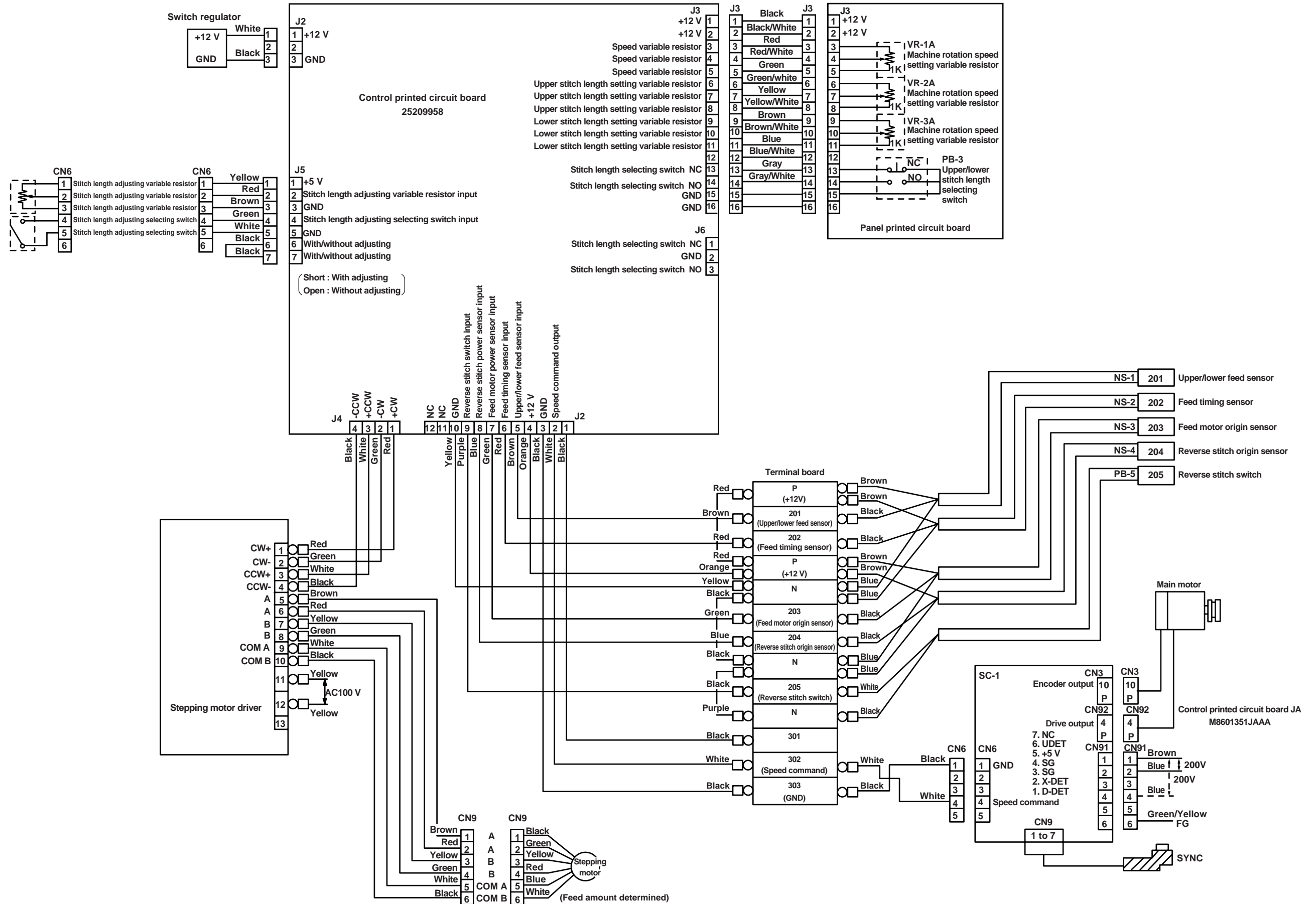

(2) Wiring diagram

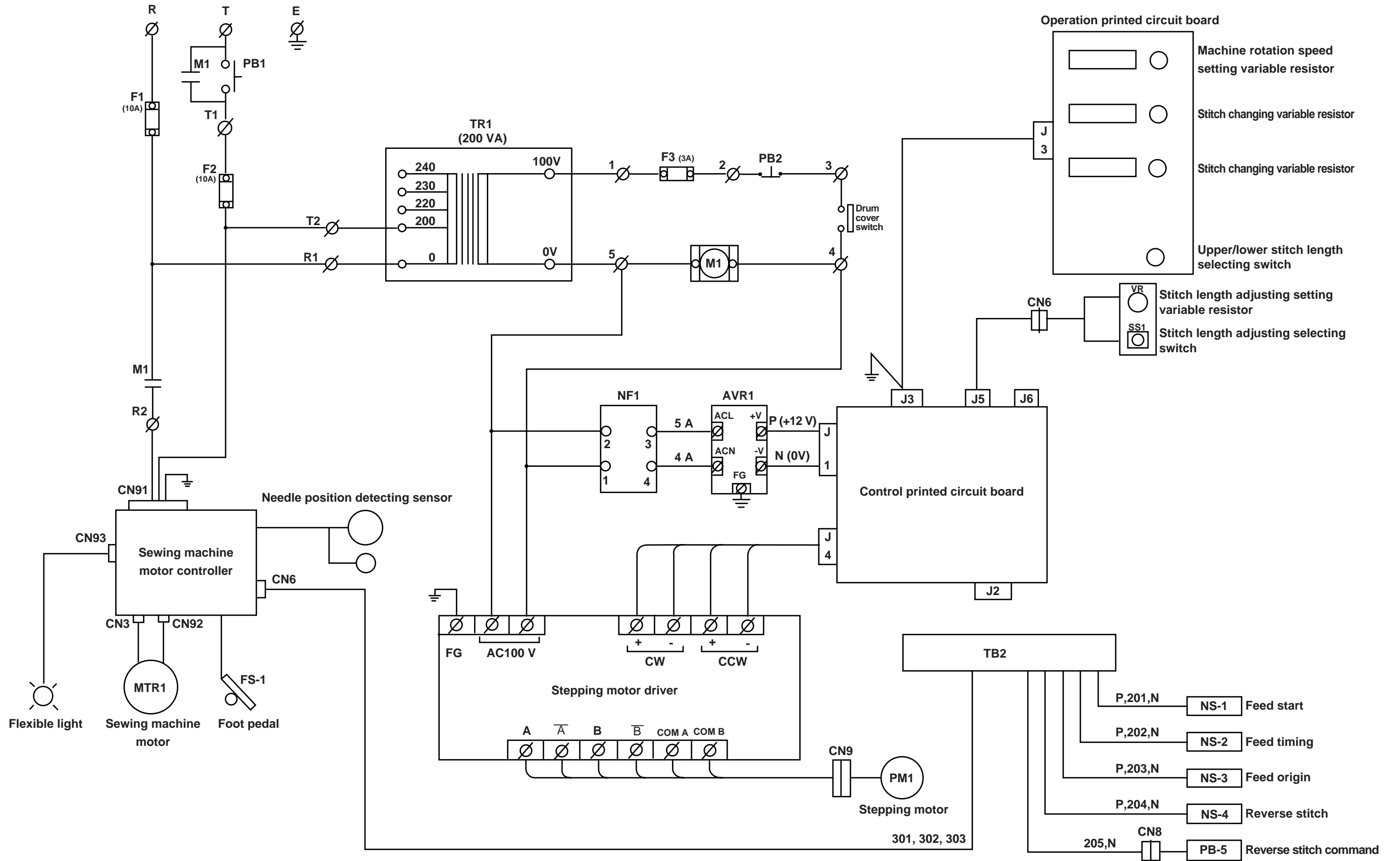

(3) Cable connection diagram

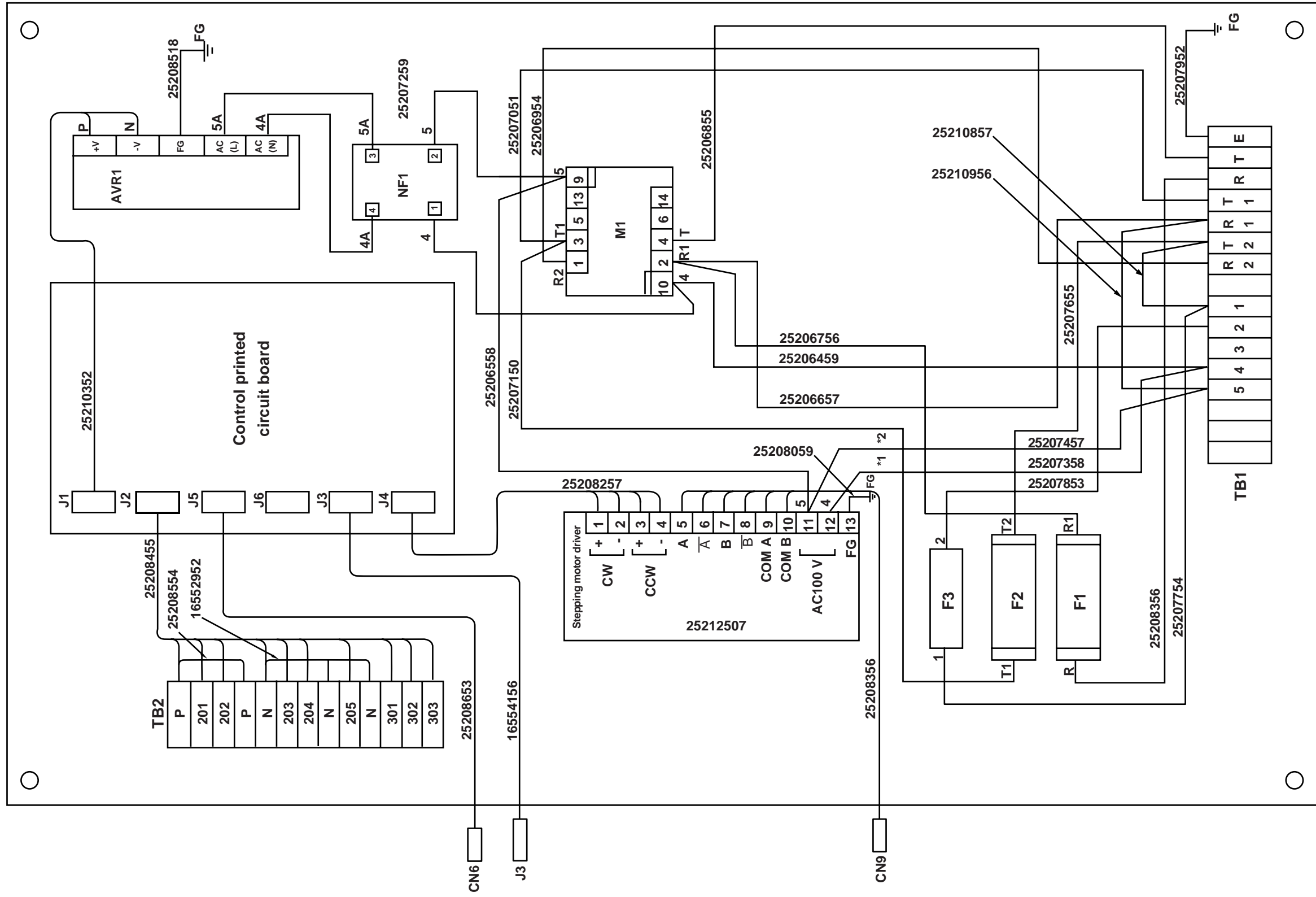

*1: 25207358 } To be the twist pair type wire.
 *2: 25207457 }

12. DRWAING OF THE TABLE

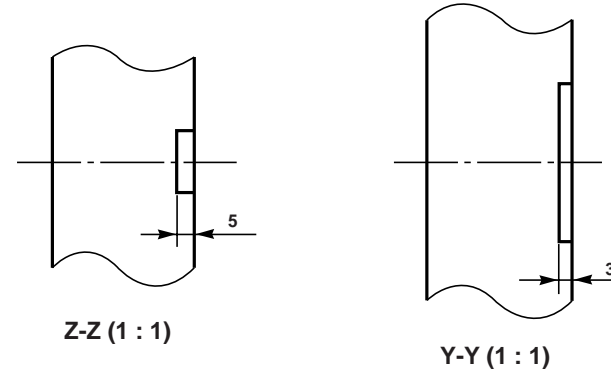
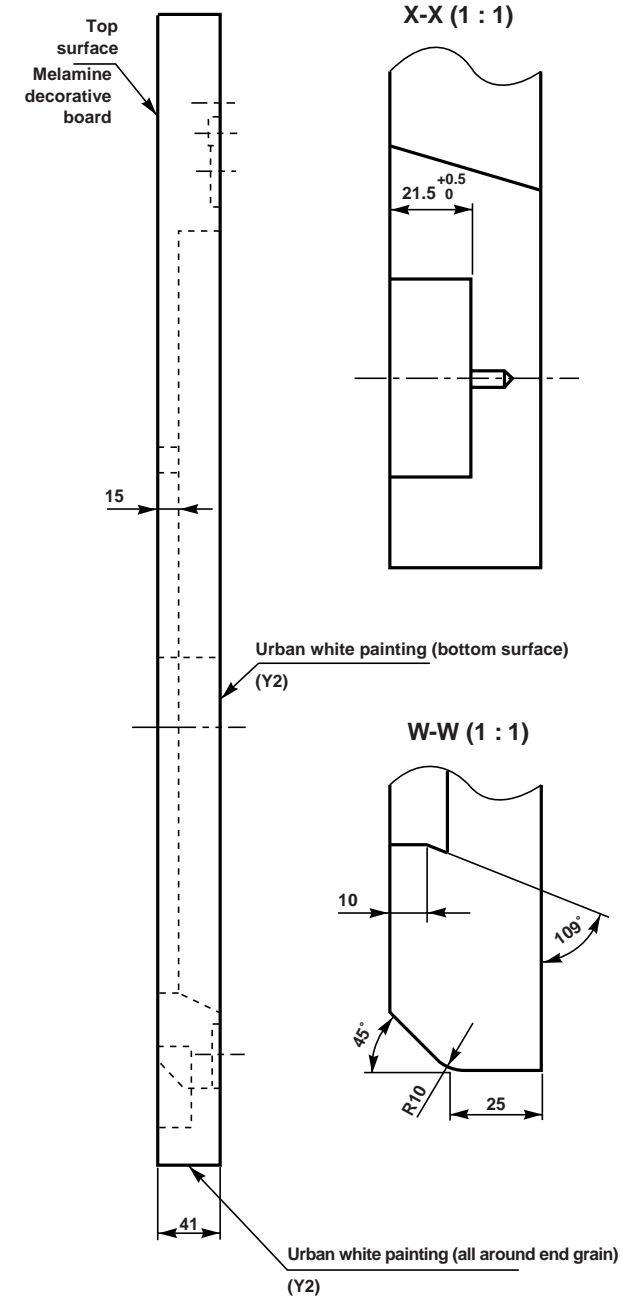
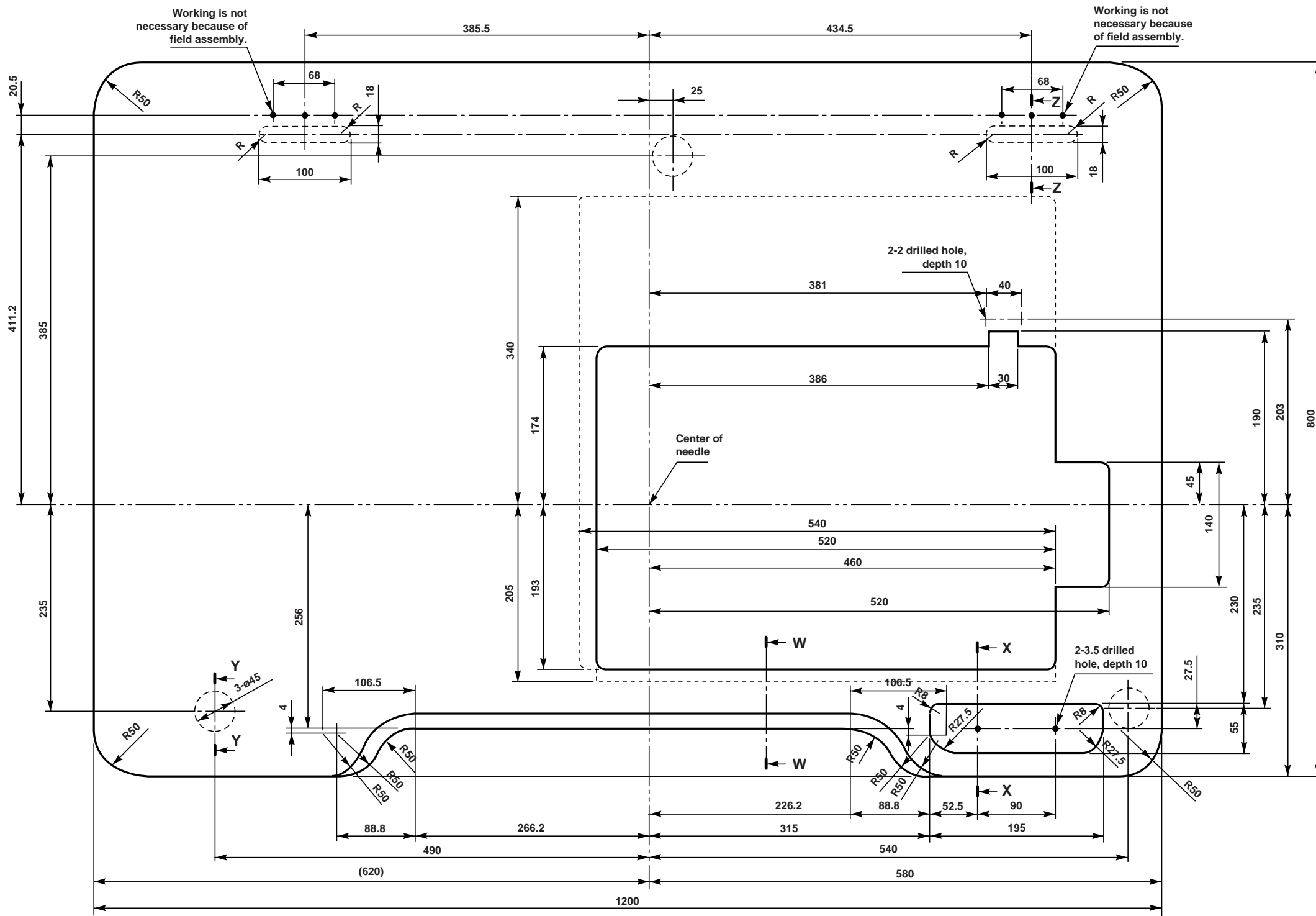

R without designation is R10.

Part No. : 25235409

Electronic Handstitching Machine

FLS-350N Series

ENGINEER'S MANUAL

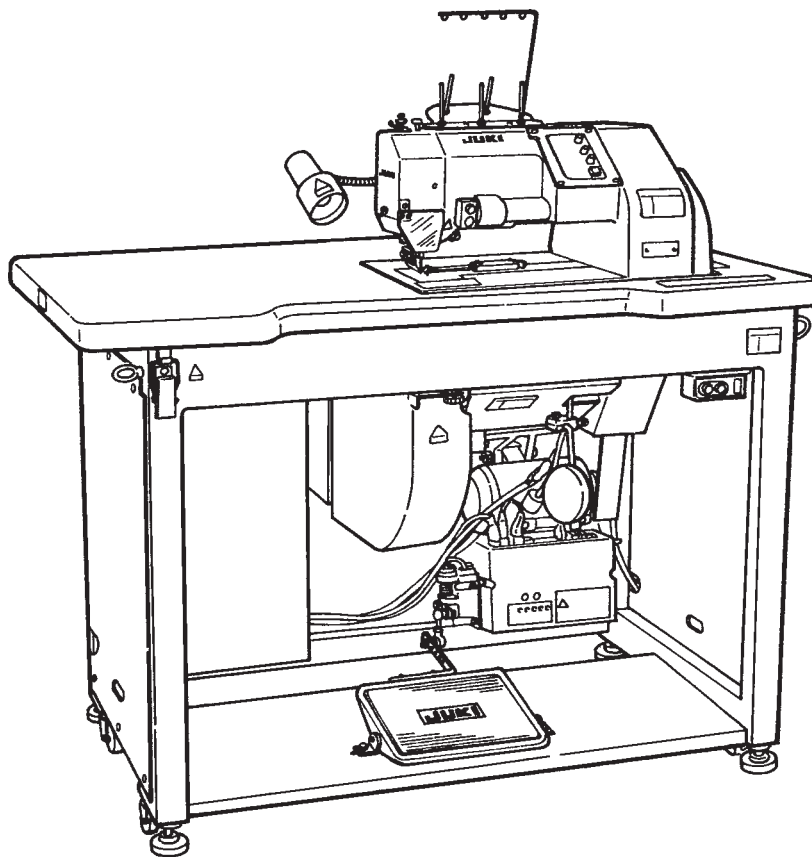

PREFACE

This Engineer's Manual is written for the technical personnel who are responsible for the service and maintenance of the machine.

The Instruction Manual for this machine intended for the maintenance personnel and operators at an apparel factory contains operating instructions in detail. And this manual describes "Standard Adjustment", "Adjustment Procedures", "Results of Improper Adjustment", and other important information which are not covered in the Instruction Manual.

It is advisable to use the relevant Instruction Manual and Parts List together with this Engineer's Manual when carrying out the maintenance service of this machine.

Regarding the motor for the sewing machine with automatic thread trimmer, separately refer to the Instruction Manual for the motor and Engineer's Manual. In addition, for the control panel, refer to the Instruction Manual for the control panel.

This manual gives the "Standard Adjustment" on the former page under which the most basic adjustment value is described and on the latter page the "Adjustment Procedures" and "Results of Improper Adjustment" under which the steps of adjusting procedure, and stitching errors and troubles arising from mechanical failures are described.

CONTENTS

1. SPECIFICATIONS	1
2. EXPLANATION OF UNITS	2
(1) Configuration	2
(2) Operation panel (① Operation panel)	3
3. EXPLANATION OF STITCH LENGTH COMPENSATION FUNCTION	5
(1) Function	5
1) In case the upper stitch becomes small	5
2) In case the upper stitch becomes large	5
(2) Operation	5
4. NEEDLE BAR CURVE AND TIMING ADJUSTMENT CHART	6
5. STANDARD ADJUSTMENT	8
(1) Before making the adjustments	8
(2) Adjusting the home position (adjusting the graduation)	8
(3) Adjusting the needle bar groove cam and the left looper cam	10
(4) Adjusting the needle bar	12
1) Adjusting the height of the support cylinder of the upper needle bar	12
2) Adjusting the height of the support cylinder of the lower needle bar	12
3) Adjusting the timing of transferring the needle	14
4) Centering the needle bar	14
(5) Adjusting the needle guide claw	16
1) Adjusting the needle and the needle guide claw	16
2) Adjusting the thread tension of the needle guide claw	16
3) Adjusting the timing of opening/closing the tubular cam of the needle guide claw	18
(6) Adjusting the thread path guide	18
(7) Adjusting the thread haul lever	20
1) Cam timing	20
2) Adjusting the thread haul lever	20
(8) Adjusting the brush cam	22
(9) Adjusting the hook finger	22
1) Adjusting the movement amount of the hook finger	22
2) Adjusting the rotating shaft and the tension spring	24
3) Adjusting the clearance between the hook finger and the needle	24
(10) Adjusting the hook finger to release the thread tension	26
(11) Adjusting the eccentric amount of the eccentric pin	26
(12) Adjusting the lower feed	28
1) Adjusting the feed eccentric boss and the lifting cam	28
2) Adjusting the height of the lower feed dog and the throat plate	28
(13) Adjusting the upper feed dog and the lower feed dog	30
(14) Adjusting the presser foot	30
(15) Adjusting the upper feed eccentric shaft	32

(16) Adjusting the left looper	32
(17) Adjusting the right looper cam	34
(18) Adjusting the right looper	34
1) Adjusting the right looper pin	34
2) Adjusting the relationship between the right looper and the needle	36
(19) Adjusting the position of the ellipse gear	36
(20) Adjusting the lower looper	38
1) Adjusting the lower looper arm	38
2) Disassembling and assembling the lower looper	38
(21) Adjusting the command block and the proximity sensor	40
(22) Adjusting the feed, reverse stitching position, and the proximity sensors	40
(23) Adjusting the needle stopping position	42
(24) Adjusting the tension of the timing belt of the feed stepping motor	44
(25) Adjusting the threader needle during replacement	44
(26) Adjusting the angle of the foot pedal, and the foot pressure of the pedal (FLS-350N only)	46
(27) Servomotor controller box connection diagram	46
(28) Disassembling/assembling the needle bar	48
(29) Removing the snap ring when disassembling the needle bar	50
6. ELECTRICAL COMPONENTS	52
(1) Printed circuit boards in the control box	52
7. MAINTENANCE AND INSPECTION	53
(1) Electrical components	53
(2) Mechanical components	53
(3) Consumable parts replacing period table	55
8. ERROR CODES	56
9. TROUBLES AND CORRECTIVE MEASURES	57
(1) Mechanical components	57
(2) Electrical components	59
10. TIME CHART	61
11. CIRCUIT DIAGRAM	62
(1) Layout drawing of the control box	62
(2) Circuit diagram	63
(3) Cable wiring diagram	64
12. DRAWING OF THE TABLE	65

JUKI®

JUKI CORPORATION

INTERNATIONAL SALES H.Q.
8-2-1, KOKURYO-CHO,
CHOFU-SHI, TOKYO 182-8655, JAPAN
PHONE : (81)3-3430-4001 to 4005
FAX : (81)3-3430-4909 • 4914 • 4984
TELEX : J22967

Copyright © 1997-2001 JUKI CORPORATION.
All rights reserved throughout the world.

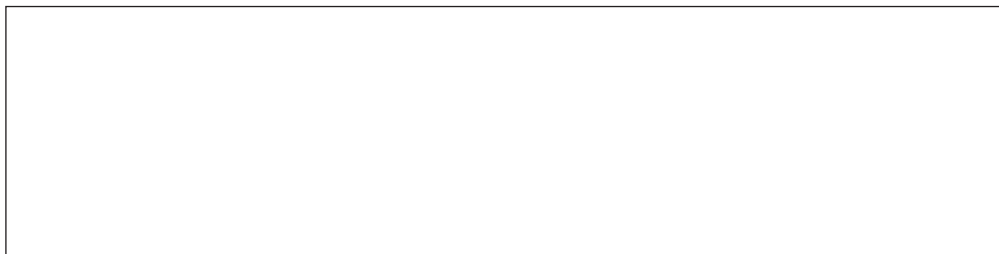

Please do not hesitate to contact our distributors or agents in your area for further information when necessary.
*** The description covered in this engineer's manual is subject to change for improvement of the commodity without notice.**