

**JUKI**

Cylinder-bed, Unison-feed Lockstitch Machine

**DSC-245**

Cylinder-bed, Unison-feed Lockstitch Machine  
with Automatic Thread Trimmer

**DSC-245-4 • DSC-245-5**

**ENGINEER'S MANUAL**

---

## PREFACE

This Engineer's Manual is written for the technical personnel responsible for the servicing and maintenance of sewing machines. The manual describes "How to adjust," "Results of improper adjustment" and other functions not covered by the Instruction Manual intended for the maintenance personnel and sewing machine operators at sewing factories.

When doing maintenance work on this sewing machine, it is recommended that you refer to the Instruction Manual and Parts List in addition to this Engineer's Manual.

In this Engineer's Manual, the "Standard adjustments," which describe the basic standard adjustment values, are explained prior to "How to adjust" and "Results of improper adjustment" which describe sewing troubles and mechanical problems.

## CONTENTS

1. SPECIFICATIONS .....	1
2. STANDARD ADJUSTMENT OF THE MAIN UNIT .....	2
(1) Height of the needle bar .....	2
(2) Timing relationship between the needle and the hook .....	2
(3) Height of the feed dog .....	4
(4) Longitudinal position .....	4
(5) Timing of the feed movement .....	6
1) Vertical feed cam .....	6
2) Eccentric feed cam .....	6
(6) Top feed movement .....	8
(7) Timing of the top feed cam .....	10
(8) Stitch length for normal feed or reverse feed .....	12
(9) Lubrication (hook) .....	14
3. STANDARD ADJUSTMENTS OF ADDITIONAL DEVICES .....	16
(1) Thread trimmer .....	16
1) Timing of the thread trimmer .....	16
2) Maximum oscillation point of the moving knife .....	16
3) Cam roller arm presser .....	18
4) Amount of picker movement .....	18
5) Pressure of the counter knife .....	20
6) Cam roller and the periphery of the thread trimmer cam .....	20
(2) Automatic reverse feed device .....	22
4. THREAD TRIMMER COMPONENTS .....	24
5. ASSEMBLING/DISASSEMBLING THE THREAD TRIMMER COMPONENTS .....	26
6. SYNCHRONIZER .....	28
7. LIST OF SELECTABLE PARTS FOR JOINING .....	30
8. PARTS TO BE APPLIED WITH LOCK-TITE PAINT .....	30
9. COMPONENTS TO BE APPLIED WITH A SEALING COMPOUND OR ADHESIVE AGENT .....	31
10. LIST OF CONSUMABLE PARTS .....	31
11. OPTIONAL PARTS .....	32
12. TAPE SEWING ATTACHEMENT .....	32
13. TROUBLESHOOTING (MECHANICAL PARTS) .....	36
14. TROUBLESHOOTING (SEWING CONDITION) .....	37
15. TROUBLESHOOTING FOR THE ADDITIONAL DEVICES .....	39
16. INSTALLATION DIAGRAM OF KNEE LIFTER .....	43
17. DIAGRAM OF THE MACHINE TABLE .....	43

## 1. SPECIFICATIONS

No.	Item	Specification	
1	Model number	DSC-245	DSC-245-5
2	Model name	1-Needle, cylinder-bed, unison-feed, lockstitch machine	1-Needle cylinder-bed, unison-feed, lockstitch machine with an automatic thread trimmer (automatic reverse)
3	Applications	Ordinary fabric, vinyl leather, leather (medium-weight material)	
4	Sewing speed	Max. 2,200 s.p.m.	
5	Needle	DP x 17 #14 to #21 (SCHMETZ System 135 x 17)	
6	Thread	#50 to #20	
7	Stitch length (normal x reverse)	6 mm x 6 mm	
8	Lift of the presser foot	Hand lifter 9 mm Knee lifter 15 mm	Hand lifter 8 mm Knee lifter 13 mm
9	Stitch length adjustment mechanism	Wedge type dial	
10	Reverse stitch	By a lever	Touch-back type
11	Thread take-up	Slide type	
12	Needle bar stroke	36 mm	
13	Alternating vertical movement	3 to 4.8 mm	
14	Hook	Horizontal, fully rotational, self-lubricating	
15	Feed mechanism	Forked link oscillation method	
16	Walking foot mechanism	Linked to the bottom feed	
17	Drive mechanism of the main shaft and hook driving shaft	Bevel gear	
18	Lubrication	Manual, Self-lubricating hook with a plunger pump	
19	Thread trimming mechanism		Oscillating knife on the end of the hook
20	Disk floating mechanism		By the outside-mounted magnet
21	Lubrication oil	New defrix Oil No. 1	
22	Sewing area depth	264 mm	
23	Cylinder diameter	ø 46 mm	
24	Motor	4P - 400W	
25	Conducting belt	M-type V-belt	

## 2. STANDARD ADJUSTMENT OF THE MAIN UNIT

## (1) Height of the needle bar

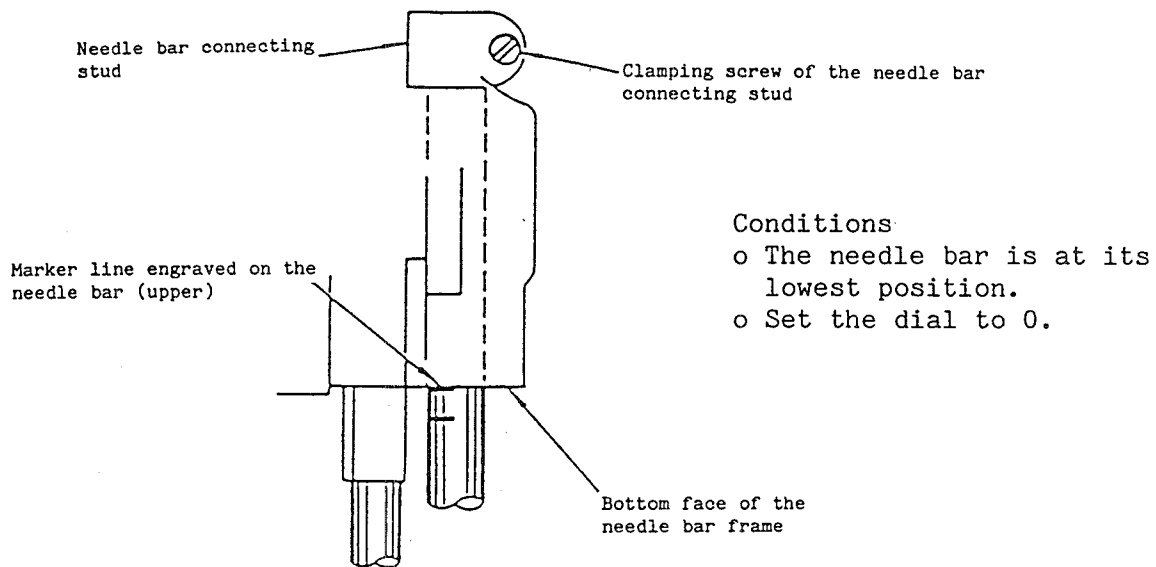

## (2) Timing relationship between the needle and the hook

## (1) Lift amount of the needle, and the position of the needle and blade point of the hook

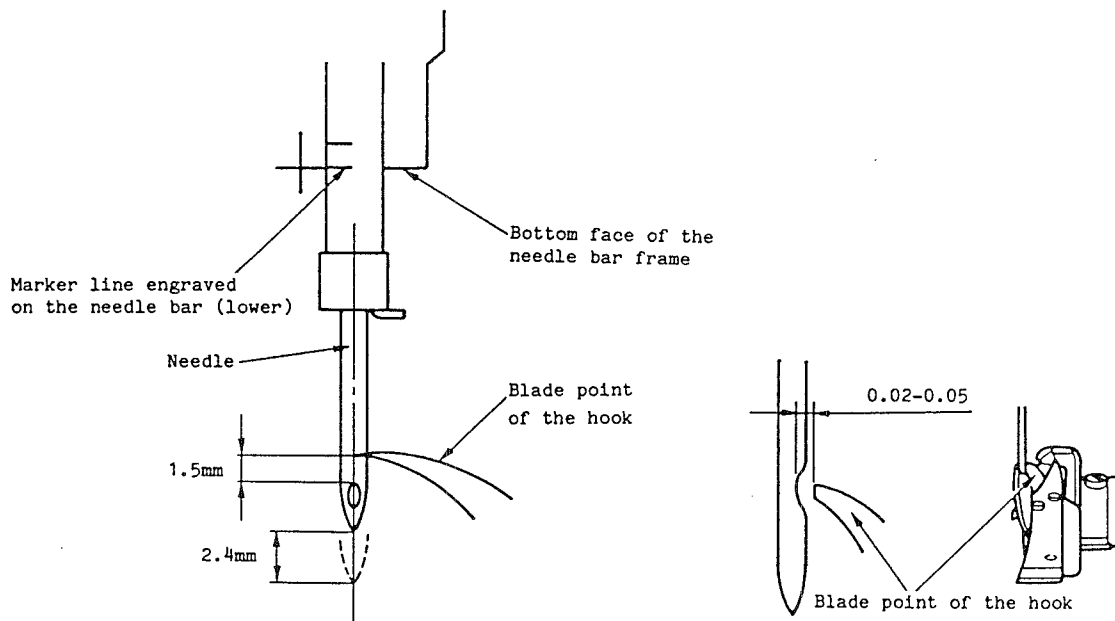

## Condition

- o The needle bar goes up from the lowest position of its stroke.
- o Set the dial to 0.

HOW TO ADJUST	RESULTS OF IMPROPER ADJUSTMENT
<ol style="list-style-type: none"> <li>1. Turn the handwheel so that the needle bar reaches the lowest dead point of its stroke.</li> <li>2. Loosen the clamping screw of the needle bar connecting stud.</li> <li>3. Align the needle bar with the engraved upper marker line, and tighten the clamping screw of the needle bar connecting stud.</li> </ol> <p><b>(Caution)</b> Use the marker line engraved on the needle bar only as a reference point when adjusting the distance between the needle and the blade point of the hook. Note that the distance between the upper end of the needle eyelet and the blade point of the hook should be 1.5 mm when the center of the needle is aligned with the blade point of the hook.</p>	<ul style="list-style-type: none"> <li>o Stitch skipping or thread breakage may occur, if the distance between the needle and the blade point of the hook is not properly adjusted.</li> </ul>
<ol style="list-style-type: none"> <li>1. Loosen the throat plate setscrew and remove the throat plate.</li> <li>2. Raise the needle bar by 2.5 mm from its lowest dead point.</li> <li>3. To adjust the clearance between the needle and the blade point of the hook, loosen the hook setscrews, move the hook in the direction of the arrow until the specified clearance is obtained, and then tighten the setscrew.</li> <li>4. To adjust the position of the needle and the blade point of the hook, loosen the hook setscrews and turn the hook by hand until the center of the needle is aligned with the blade point of the hook.</li> </ol> <div data-bbox="446 1612 885 1858" style="text-align: center;"> <p>The three hook setscrews</p> </div>	<ul style="list-style-type: none"> <li>o Irregular stitches, stitch skipping or thread breakage.</li> <li>● Irregular stitches such as isolated idling loops will be observed if the hook timing is too early or too late.</li> <li>● Irregular stitches may be prevented if the hook timing is set so that it is relatively late.</li> <li>● If the hook timing is set so that it is late, the thread tension will be decreased.</li> <li>● Any isolated idling loops in lockstitching will be eliminated if the hook timing is set so that it is earlier.</li> <li>o It may not be possible for the needle thread to be trimmed.</li> </ul>

(3) Height of the feed dog

Conditions

- o The feed amount is set to 0.
- o The section of the feed dog protruding most should be 0.8 mm higher than the surface of the throat plate.

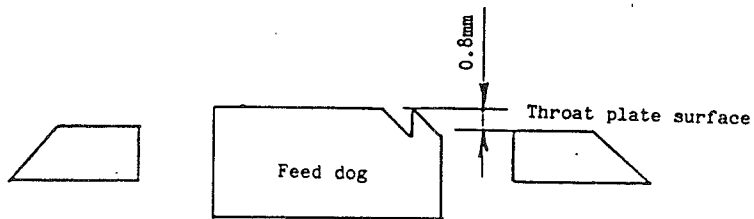

(4) Longitudinal position

Conditions

- o Feed amount: Max. 6 mm
- o Longitudinal clearances A and B between the feed dog and throat plate should be equal (for both normal feeding and reverse feeding).

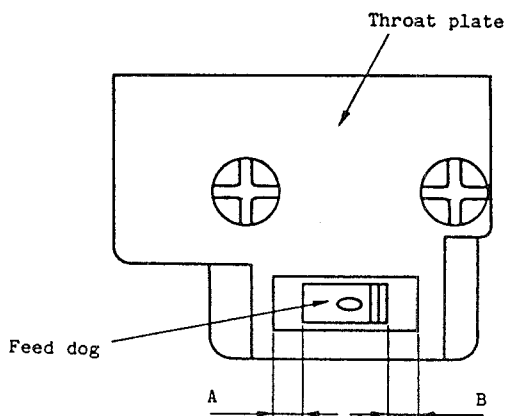

## HOW TO ADJUST

## RESULTS OF IMPROPER ADJUSTMENT

### 1) Height of the feed dog

1. Set the feed regulating dial to 0.
2. Remove the throat plate, top face cover of the bed, and spring support shaft. Then pull out the feed bar.
3. If the height of the feed dog is inadequate, use a feed driving pin with many marker lines engraved on its surface. If the feed dog is positioned too high, use a feed driving pin with fewer marker lines engraved on its surface.

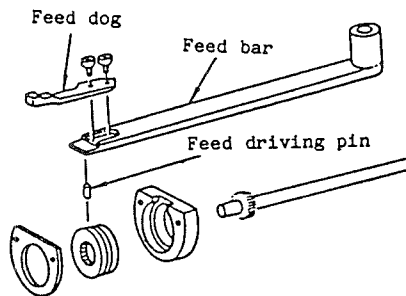
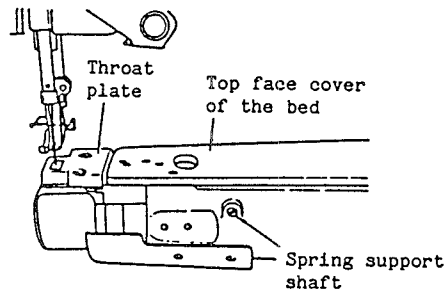

If the feed dog is positioned too high:

- o The feed dog may come in contact with the throat plate.
- o The actual stitch length may become greater than the value set on the feed regulating dial.
- o Irregular stitches may be formed.

If the feed dog is positioned too low:

- o The stitch length may actually become smaller than the value set by the feed regulating dial.
- o The feed force may be decreased.

1. Set the feed regulating dial to 6.
2. Loosen the rocker clamping screw and adjust so that the feed dog moves evenly with regard to the groove in the throat plate. Then fix the feed rocker clamping screw. (Loosen the clamping screw using the hexagonal wrench key supplied with the unit.)

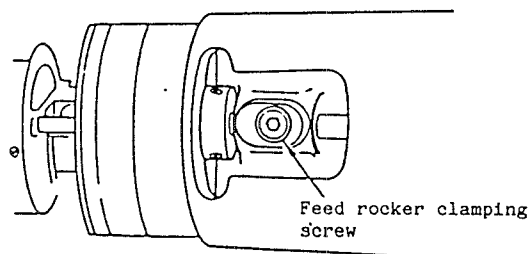

- o The feed dog will come in contact with the throat plate, and a hitting noise will be heard.
- o Irregular stitches may be observed.

**(5) Timing of the feed movement****1) Vertical feed cam****Conditions**

- o Feed amount: 6 mm
- o The tip of the needle should be aligned with the surface of the throat plate when the tip of the feed dog is aligned with the surface of the throat plate.

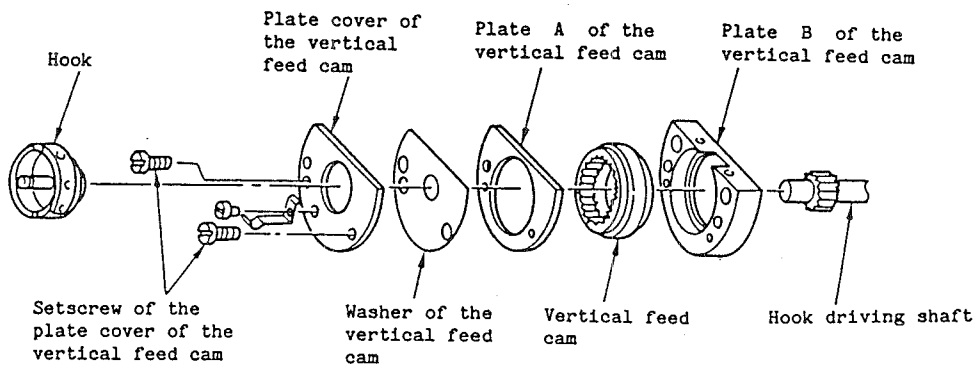
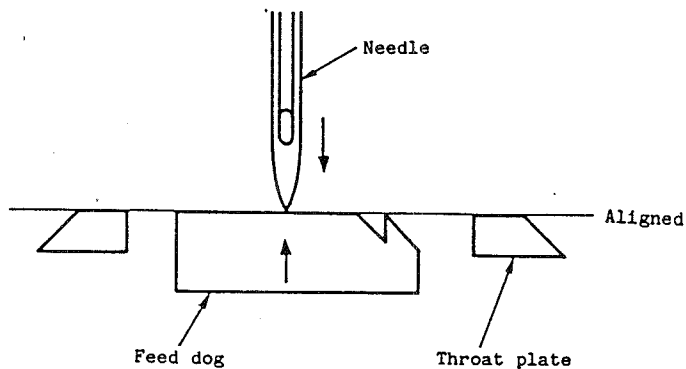

Configuration of the vertical feed cam assembly

**2) Eccentric feed cam****Conditions**

- o Feed amount: 6 mm
- o When the needle bar goes up from the lowest dead point of its stroke by 2.4 mm, the feed dog does not move even if the lever is lowered.

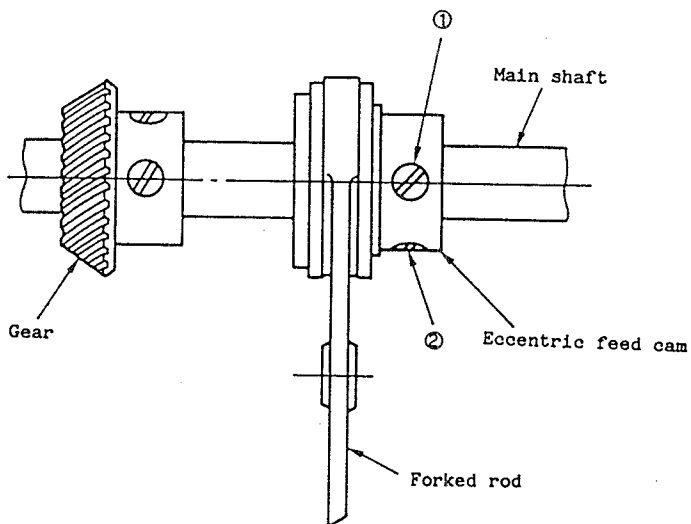



## HOW TO ADJUST

1. Remove the hook. (See Instruction manual for details on the cover removal procedure.)
2. Loosen the two setscrews of the plate cover of the vertical feed cam, and remove the plate cover, the plate washer, and plate A of the vertical feed cam.
3. Turn the handwheel until the lower marker line engraved on the needle bar is aligned with the bottom of the needle bar frame. (At this time, the needle bar goes up by 2.4 mm from its lowest position.)
4. Install the vertical feed cam so that the notch mark on the vertical feed cam is positioned as illustrated in the figure.

### (Caution)

The surface of the throat plate, the tip of the needle, and the tip of the feed dog should all be aligned with each other.

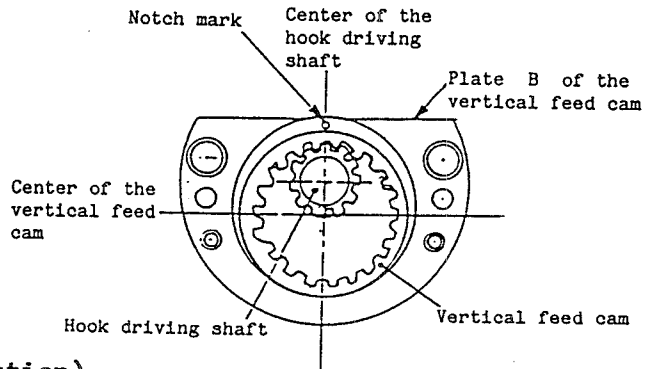

### (Caution)

If the gear fails to engage, adjust so that the notch mark moves to the left by one gear tooth.

## RESULTS OF IMPROPER ADJUSTMENT

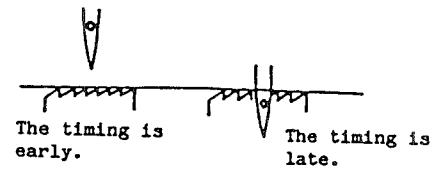

If the timing of the vertical feed cam is too early:

- o Isolated idling loops may be eliminated, but loose stitches may occur.

If the timing of the vertical feed cam is too late:

- o Irregular stitches may be caused, although loose stitches may be eliminated.
- o The needle may break.

1. Loosen setscrews ① and ② of the eccentric feed cam.
2. Turn the eccentric feed cam until the feed dog no longer moves with the feed lever lowered when the needle bar goes up by 2.4 mm from the lowest position of its stroke.
3. Make sure that the top feed does not move backward. Then tighten the setscrews.

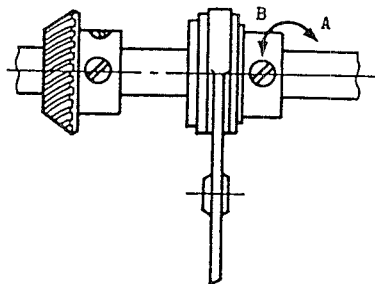

### (Caution)

If the cam has been adjusted so that it has been moved out of its correct position toward the shaft, smooth cam operation may be hindered.

- o The stitch length during normal feed or reverse feed may not be of the value set.
- o Irregular stitches may occur.

## (6) Top feed movement

## 1) Longitudinal position of the walking foot (needle entry point)

## Conditions

- o Feed amount: 0 mm
- o The needle should enter the center of the needle hole in the feed dog.

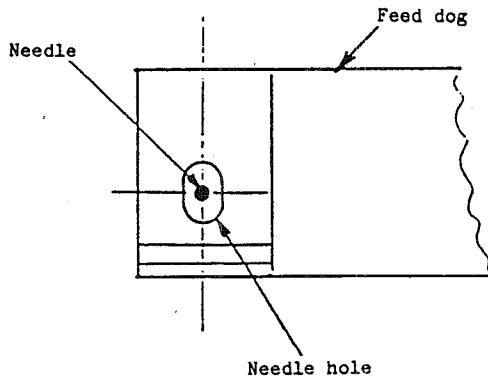

## 2) Alternating movement

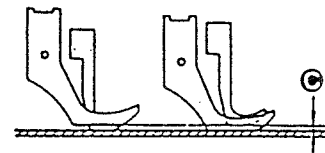
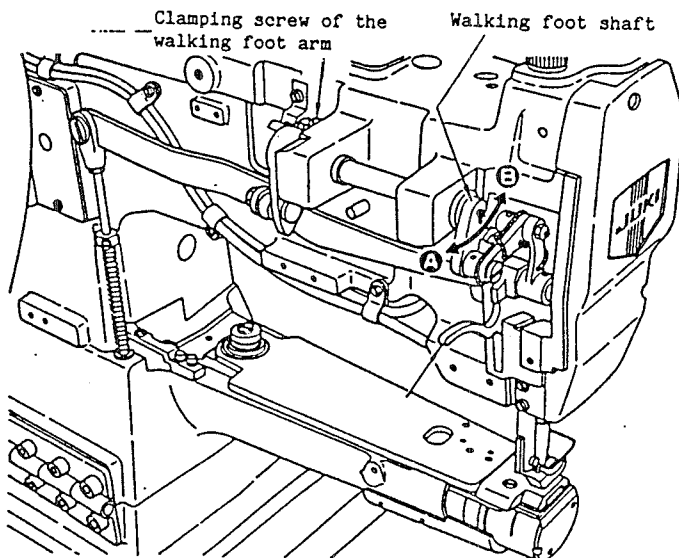

C: equal

## Conditions

- o Feed amount: 0
- o The alternating movement of the walking foot and presser foot should be equal.

HOW TO ADJUST	RESULTS OF IMPROPER ADJUSTMENT
<ol style="list-style-type: none"> <li>1. Set the dial to 0.</li> <li>2. Loosen the clamping screw of the rear crank of the frame rocking shaft.</li> <li>3. Turn the handwheel and move the needle bar frame so that the needle enters the center of the needle hole in the feed dog. Then tighten the clamping screw.</li> </ol> <div data-bbox="370 596 797 894" style="text-align: center;"> </div> <p data-bbox="418 905 781 951" style="text-align: center;">Clamping screw of the rear crank of the frame rocking shaft</p>	<p>If the needle entry point is significantly different from the center of the needle hole in the feed dog:</p> <ul style="list-style-type: none"> <li>o The walking foot components may come in contact with each other, resulting in abnormal operating noise.</li> <li>o The needle might break.</li> </ul>
<ol style="list-style-type: none"> <li>1. Remove the top feed front cover and open the top feed rear cover.</li> <li>2. Turn the handwheel by hand until the thread take-up reaches the lowest position of its stroke.</li> <li>3. Lower the presser bar lifting lever.</li> <li>4. Loosen the clamping screw of the top feed arm.</li> <li>5. Move the top feed shaft in direction <b>(A)</b>. The vertical stroke of the presser foot will be decreased, while that of the walking foot will be increased.</li> <li>6. Move the top feed shaft in direction <b>(B)</b>. The vertical stroke of both the walking foot and presser foot will be equal.</li> </ol>	<ul style="list-style-type: none"> <li>o Adjust the vertical stroke of the walking foot so that it is larger than that of the presser foot in accordance with the type of material to be sewn. <ul style="list-style-type: none"> <li>o Sewing sponge material.</li> <li>o Sewing material with overlapped sections.</li> <li>o Sewing piping.</li> </ul> </li> <li>o If the alternating vertical strokes of the walking foot and presser foot are significantly different: <ul style="list-style-type: none"> <li>● The stitch length may actually be different from the value set by the dial.</li> <li>● The feed efficiency may be decreased.</li> </ul> <p>The rate of rotation of the motor must therefore be decreased.</p> </li> </ul>

## 3) Alternating vertical movement

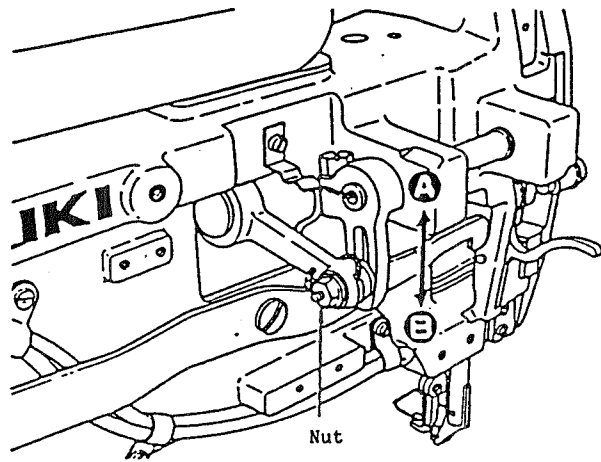

## Condition

- o Align the boss with the engraved marker dot "1/8" as shown in the figure.

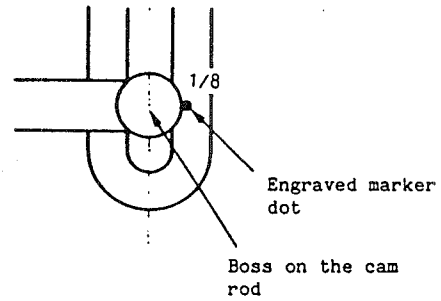

## (7) Timing of the top feed cam

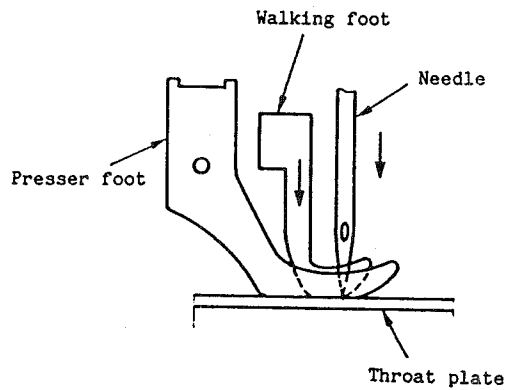

## Condition

- o The walking foot is aligned with the surface of the feed dog when the needle comes down and the tip of the needle reaches the surface of the throat plate.

HOW TO ADJUST	RESULTS OF IMPROPER ADJUSTMENT
<ol style="list-style-type: none"> <li>1. Loosen the nut of the screw connecting the top feed rod.</li> <li>2. Adjust the position of the boss on the cam rod by moving the boss up or down. Then tighten the screw nut. <ul style="list-style-type: none"> <li>o If the boss is fixed in the upper section of the long hole (3/16): Amount of movement: Max. 4.8 mm</li> <li>o If the boss is fixed in the lower section of the long hole (1/8): Amount of movement: Min. 3 mm</li> </ul> </li> </ol>	<ul style="list-style-type: none"> <li>o Change the amount of movement in accordance with the type of material to be sewn. <ul style="list-style-type: none"> <li>o Sewing sponge material or the like.</li> <li>o Sewing material with overlapped sections.</li> </ul> </li> <li>o If the amount of movement is set to a larger value: <ul style="list-style-type: none"> <li>o The stitch length may actually be different from the value set by the dial.</li> <li>o The feed efficiency may be decreased. The rate of rotation of the motor must therefore be decreased.</li> </ul> </li> </ul>
<ol style="list-style-type: none"> <li>1. Loosen the two setscrews of the top feed cam.</li> <li>2. Turn the top feed cam until the surface of the throat plate, the tip of the needle and the walking foot (presser face) are all aligned with each other. Then tighten the two setscrews of the top feed cam so that the top feed cam is firmly fixed in that position.</li> </ol> <div data-bbox="342 1549 841 1990" style="text-align: center;"> </div>	<ul style="list-style-type: none"> <li>o If the timing of the top feed cam is too early (when the top feed cam is moved in direction A ): <ul style="list-style-type: none"> <li>o Loose stitches may be observed.</li> <li>o The stitch length may actually be different from the value set by the dial (smaller than the set value).</li> <li>o The walking foot may be forced to move in the opposite direction.</li> </ul> </li> <li>o If the timing of the top feed cam is too late (when the top feed cam is moved in direction B ): <ul style="list-style-type: none"> <li>o Loose stitches may be observed.</li> <li>o The needle thread is likely to finely split.</li> <li>o The stitch length may actually be different from the value set by the dial (larger than the set value).</li> </ul> </li> </ul>

**(8) Stitch length for normal feed or reverse feed****Conditions**

- o Set the dial to 6 mm.
- o Turn the handwheel so that the following is obtained.  
Normal feed amount/reverse feed amount x 100 =  $92 \pm 2\%$ .

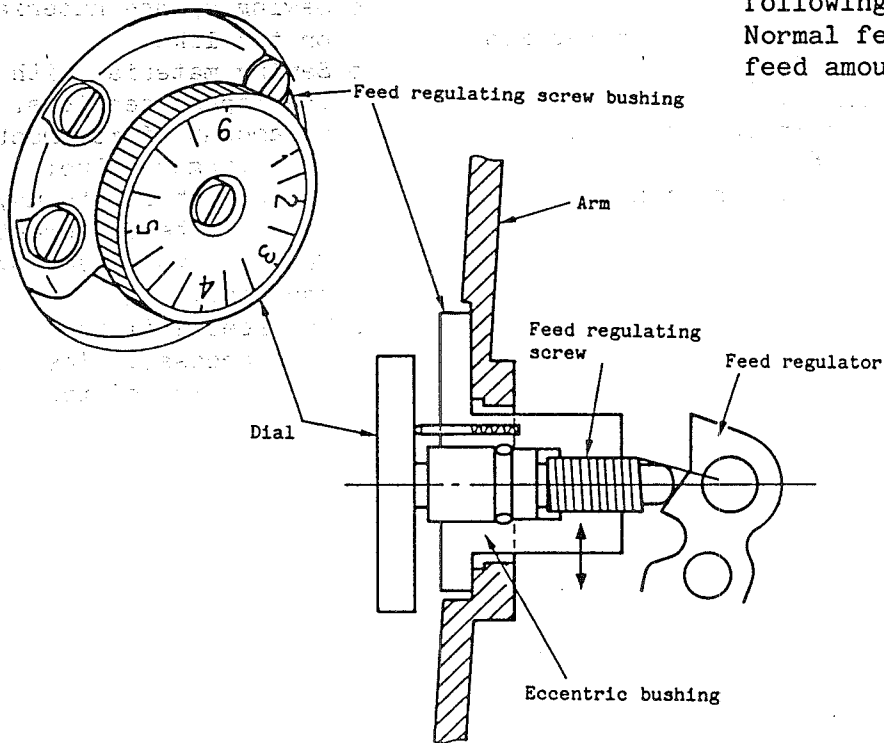
**(Caution)**

The static stitch length is set to a slightly smaller value indicated by the scale on the dial.

## HOW TO ADJUST

1. Loosen the four setscrews of the feed regulating screw bushing.
2. Set the reverse feed lever to neutral.
3. Turn the notch of the eccentric bushing using a small screwdriver.
4. Measure the clearance between the reverse feed actuating lever and the stopper pin using a ruler and check that it is 1.0 mm. Then firmly tighten the setscrews.

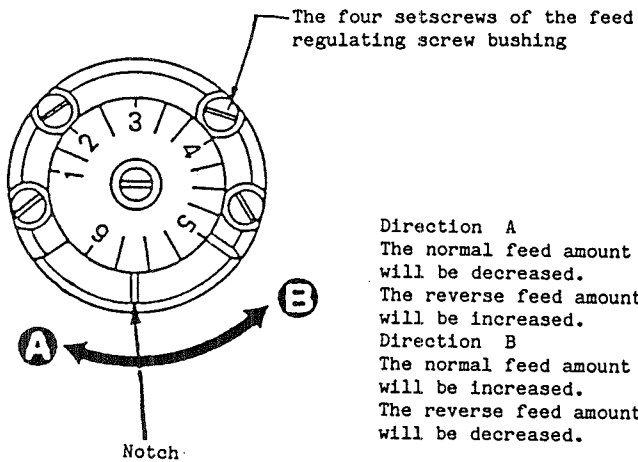

The four setscrews of the feed regulating screw bushing

Direction A  
The normal feed amount will be decreased.  
The reverse feed amount will be increased.  
Direction B  
The normal feed amount will be increased.  
The reverse feed amount will be decreased.

Notch

## RESULTS OF IMPROPER ADJUSTMENT

- o If the eccentric bushing is turned in direction A :  
Normal feed amount < Reverse feed amount

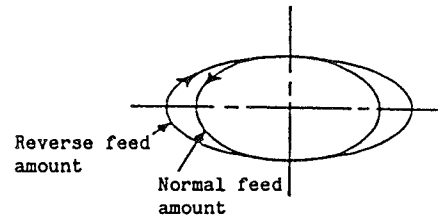

- o If the eccentric bushing is turned in direction B :  
Normal feed amount > Reverse feed amount

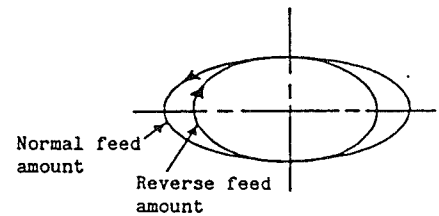

- o The stitch lengths for normal feed and reverse feed will not be matched.
- If the stitch lengths for normal feed and reverse feed are set so that they are both equal, the value set will be affected by the sewing speed, stitch length, the amount of alternating vertical feed, or the cam adjustment.

### (Caution)

If the normal feed and reverse feed amounts are frequently adjusted, the arm tap might become crushed.

## (9) Lubrication (hook)

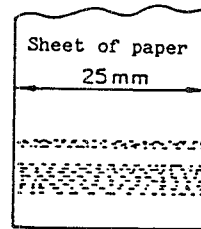
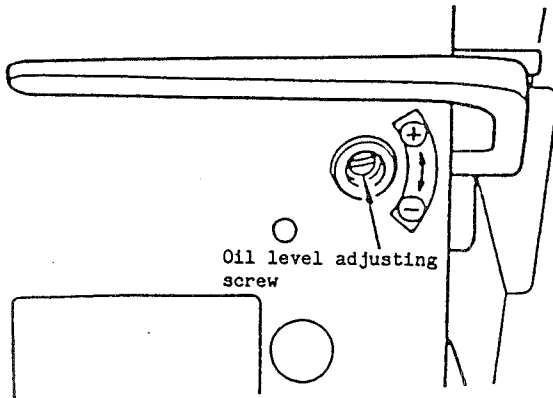
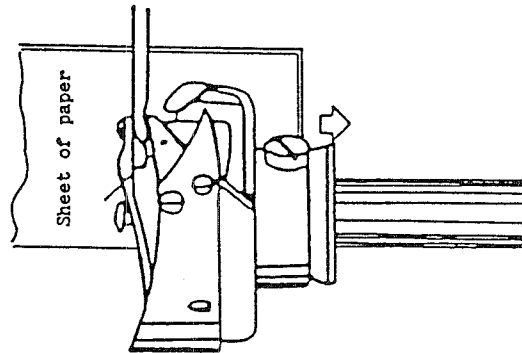
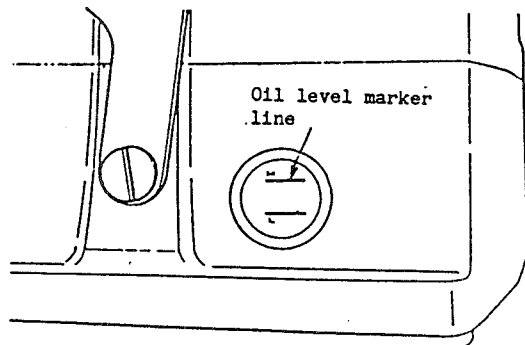

Appropriate amount  
of oil in the hook

**(Caution)**

Fill the oil tank with oil up to oil level marker line H.

**Conditions**

- o Sewing speed: 2,000 s.p.m.
- o After the sewing machine has been idling for 90 to 120 seconds, splash oil should begin collecting in lines on a sheet of paper placed 10 mm away from the peripheral of the hook, lasting for five seconds.
- o Set the dial to 3.



HOW TO ADJUST	RESULTS OF IMPROPER ADJUSTMENT
<p>1. Turning the oil level adjusting screw in the ⊕ direction (counterclockwise) will increase the amount of oil to be supplied to the hook. Turning the oil level adjusting screw in the ⊖ direction (clockwise) will decrease the amount of oil to be supplied to the hook.</p>	<ul style="list-style-type: none"> <li>o If the amount of oil supplied to the hook is inadequate, loose stitches may be formed. The hook might generate heat and is likely to quickly wear out resulting in a burned out hook. Furthermore, an insufficient supply of oil to the hook may cause irregular stitches.</li> <li>o On the other hand, if too much oil is supplied to the hook, the thread or material may become stained with oil.</li> </ul>

## 3. STANDARD ADJUSTMENTS OF ADDITIONAL DEVICES

## (1) Thread trimmer

## 1) Timing of the thread trimmer

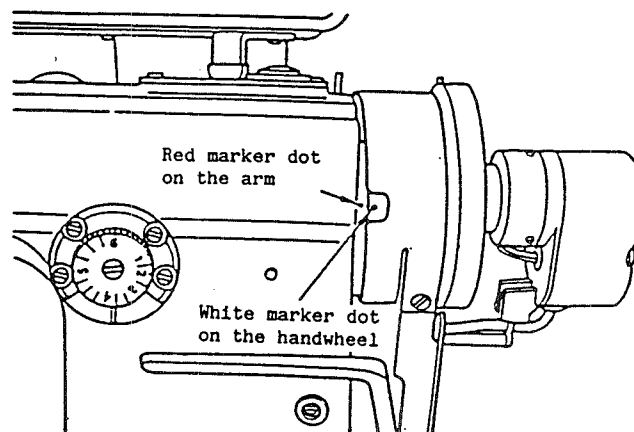
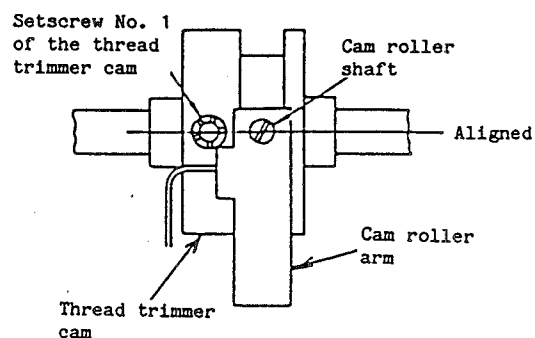

## Conditions

- o Turn the handwheel until the red marker dot on the machine arm is aligned with the white marker dot on the handwheel. Setscrew No. 1 of the thread trimmer cam should now be aligned with the cam roller shaft.

## 2) Maximum oscillation point of the moving knife

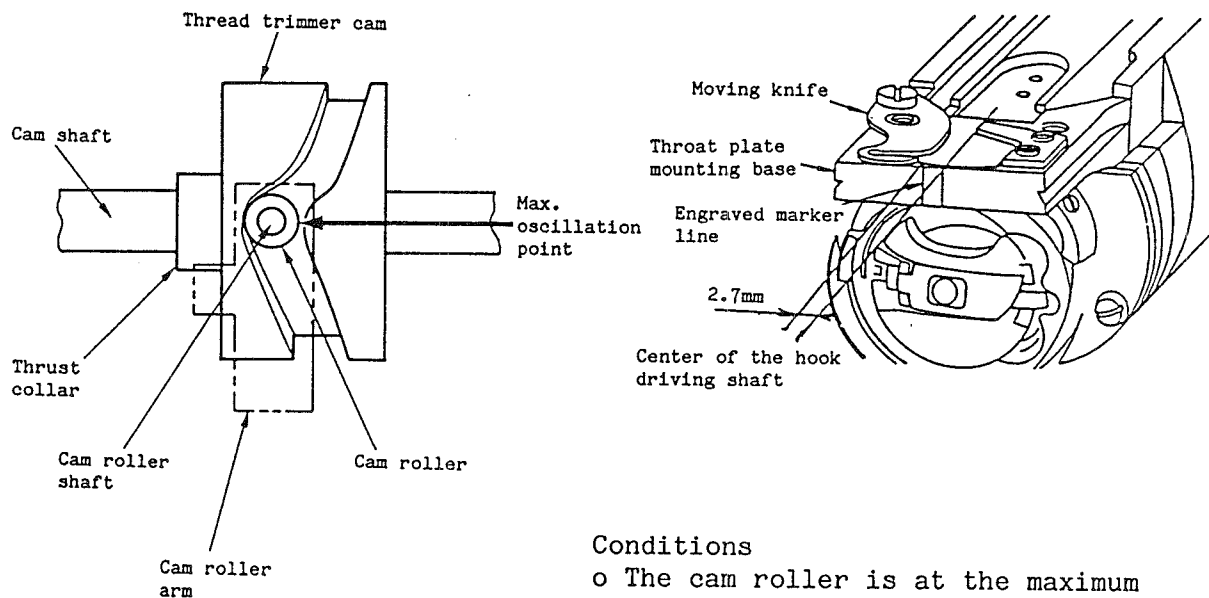

## Conditions

- o The cam roller is at the maximum oscillation point of the cam groove in the thread trimmer cam.
- o The tip of the moving knife should reach the engraved marker line on the throat plate mounting base (2.7 mm away from the center of the hook driving shaft).

## HOW TO ADJUST

1. Loosen the two setscrews of the thread trimmer cam.
2. Align the white marker dot on the handwheel with the red marker dot on the machine arm.
3. Press the cam roller arm until the cam roller fits in the groove in the thread trimmer cam.
4. Turn the thread trimmer cam until setscrew No. 1 of the thread trimmer cam is aligned with the cam roller shaft. Then tighten the two setscrews of the thread trimmer cam.

### (Caution)

Be sure to firmly tighten the two setscrews of the thread trimmer cam. If they become loose, it may result in faulty thread trimming or knife breakage.

## RESULTS OF IMPROPER ADJUSTMENT

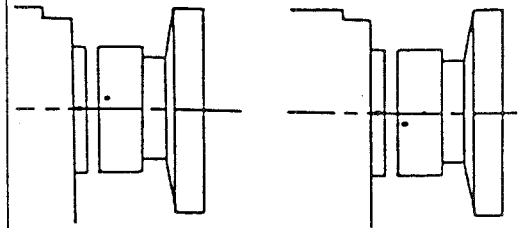

The timing is too early.

The timing is too late.

If the timing of the thread trimmer is too early:

- o The needle thread remaining in the needle may be too short.
- o The needle thread may slip off the needle eyelet.

If the timing of the thread trimmer is too late:

- o The needle thread remaining in the needle may be too long.
- o The clearance between the throat plate and the tip of the needle may be decreased when the machine stops with the needle up.

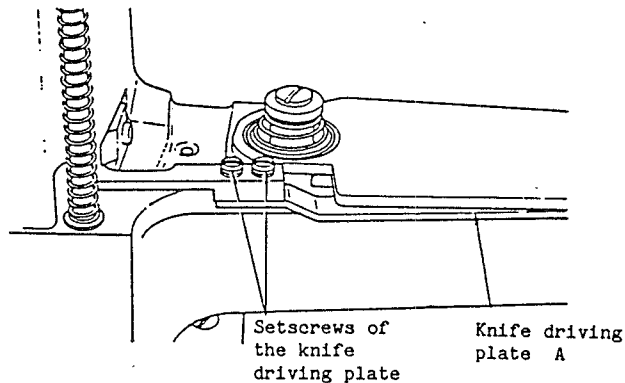

Setscrews of the knife driving plate

Knife driving plate A

1. Align the white marker dot on the handwheel with the red marker dot on the machine arm.
2. Press the cam roller arm until the cam roller fits in the groove in the thread trimmer cam.  
Then turn the handwheel until the cam roller reaches the maximum oscillation point of the groove in the thread trimmer cam.
3. Loosen the two setscrews of the knife driving plate and adjust the length of knife driving plate A so that the tip of the moving knife travels to the marker line engraved on the throat plate mounting base. (If the value for length A is large, the amount of knife movement will be decreased. If the value for length A is small, the amount of knife movement will be increased.)

If the amount of knife movement is inadequate:

- o Defective thread cutting may result.

If the amount of knife movement is excessive:

- o If the amount of knife movement is set to a significantly large value, the machine may lock.

## 3) Cam roller arm presser

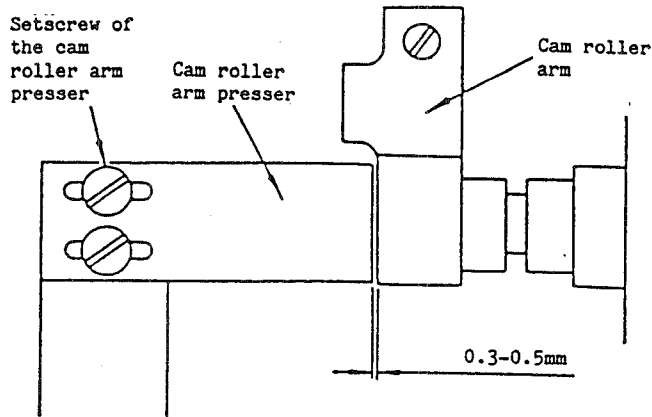

## Condition

- o The clearance between the cam roller arm and the cam roller arm presser should be 0.3 to 0.5 mm when the thread trimmer is not actuated.

## 4) Amount of picker movement

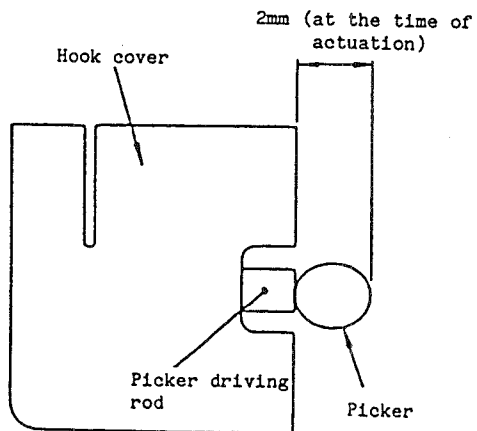

## Condition

- o The picker should move from the end face of the hook cover by 2 mm.

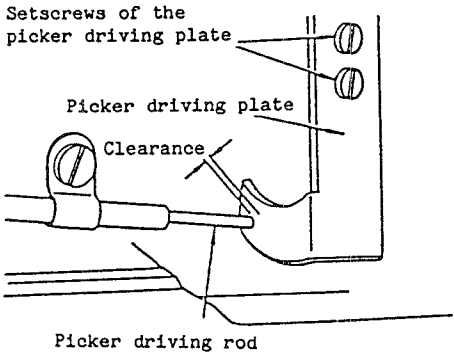
HOW TO ADJUST	RESULTS OF IMPROPER ADJUSTMENT
<ol style="list-style-type: none"> <li>1. Loosen the setscrew of the cam roller arm presser.</li> <li>2. Adjust so that a 0.3 to 0.5 mm clearance is obtained between the cam roller arm presser and the cam roller arm. Then tighten the setscrew.</li> </ol>	<p>If the clearance is inadequate:</p> <ul style="list-style-type: none"> <li>o Thread trimmer actuation will be defective. The thread trimmer may be actuated repeatedly resulting in thread trimmer breakage.</li> </ul> <p>If the clearance is too large:</p> <ul style="list-style-type: none"> <li>o Faulty thread trimming may occur.</li> </ul>
<div style="text-align: center;">  </div> <ol style="list-style-type: none"> <li>1. Align the red marker dot on the machine arm with the white marker dot on the handwheel.</li> <li>2. Loosen the two setscrews of the picker driving plate and press the plate.</li> <li>3. Adjust the clearance between the picker driving plate and the picker driving rod so that the picker travels 2 mm from the end face of the hook cover. Then, tighten the screw.</li> </ol>	<p>If the clearance is too small:</p> <ul style="list-style-type: none"> <li>o Faulty thread trimming may occur. (The thread trimmer will not cut the thread.)</li> </ul> <p>If the clearance is too large:</p> <ul style="list-style-type: none"> <li>o The needle thread will slip off the needle eyelet immediately after it has been trimmed.</li> <li>o The needle thread remaining in the needle will be too short.</li> </ul>

## 5) Pressure of the counter knife

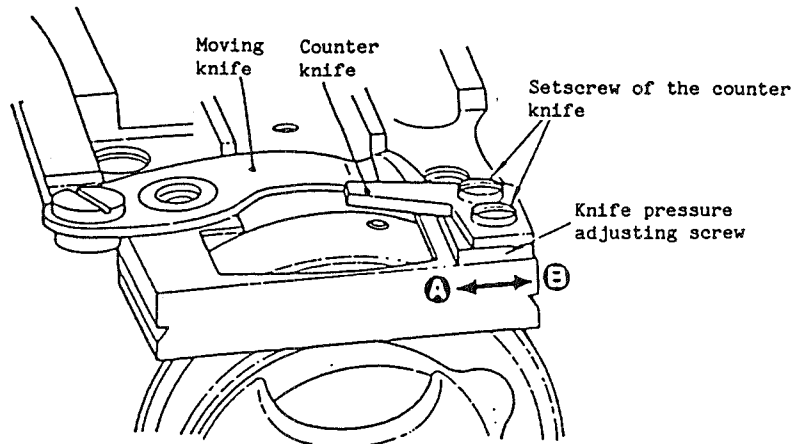

## 6) Cam roller and the periphery of the thread trimmer cam

## Condition

- o The clearance between the periphery of the thread trimmer cam and the cam roller should be  $2^{+1}_0$  mm when the thread trimmer solenoid is turned OFF.

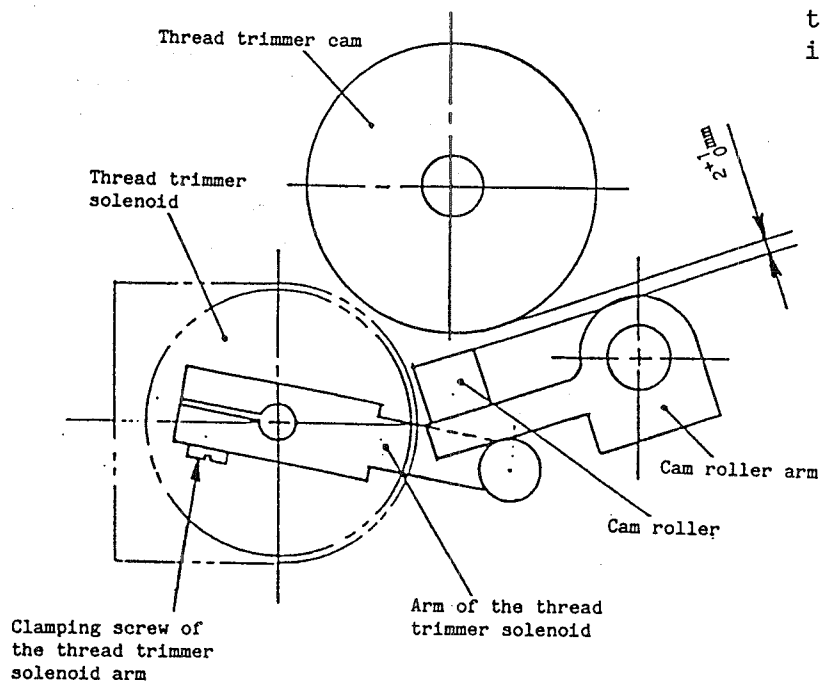

HOW TO ADJUST	RESULTS OF IMPROPER ADJUSTMENT
<ol style="list-style-type: none"> <li>1. loosen the two setscrews of the counter knife.</li> <li>2. Adjust the pressure applied to the counter knife by moving the knife pressure adjusting plate.</li> <li>3. Moving the knife pressure adjusting plate in direction A will increase the pressure applied to the counter knife. Moving the plate in direction B will decrease the pressure applied to the counter knife.</li> <li>4. Adjust so that the optimum pressure is obtained. Then tighten the setscrews.</li> </ol>	<p>If the pressure applied to the counter knife is inadequate:</p> <ul style="list-style-type: none"> <li>o Both the needle thread and bobbin thread may not be trimmed.</li> </ul> <p>If the pressure applied to the counter knife is excessive:</p> <ul style="list-style-type: none"> <li>o The machine is likely to lock.</li> </ul> <ul style="list-style-type: none"> <li>● It is advisable to use the machine with minimal pressure applied to the knife, provided that the needle thread and bobbin thread are cut successfully.</li> </ul>
<ol style="list-style-type: none"> <li>1. Loosen the clamping screw of the thread trimmer solenoid arm.</li> <li>2. Adjust the position of the thread trimmer solenoid arm so that the clearance between the periphery of the thread trimmer cam and the cam roller is <math>2^{+1}_0</math> mm, and then fix the solenoid arm by tightening the clamping screw.</li> </ol> <p><b>(Caution)</b> Check that the stroke of the thread trimmer solenoid is correct when fixing the solenoid arm. If the stroke is not proper, faulty thread cutting may occur.</p>	<p>If the clearance is too large:</p> <ul style="list-style-type: none"> <li>o The thread trimmer cannot be actuated.</li> </ul> <p>If the clearance is significantly small:</p> <ul style="list-style-type: none"> <li>o The thread trimmer will be actuated repeatedly, resulting in thread trimmer breakage.</li> </ul>

## (2) Automatic reverse feed device

## (1) Plunger stroke

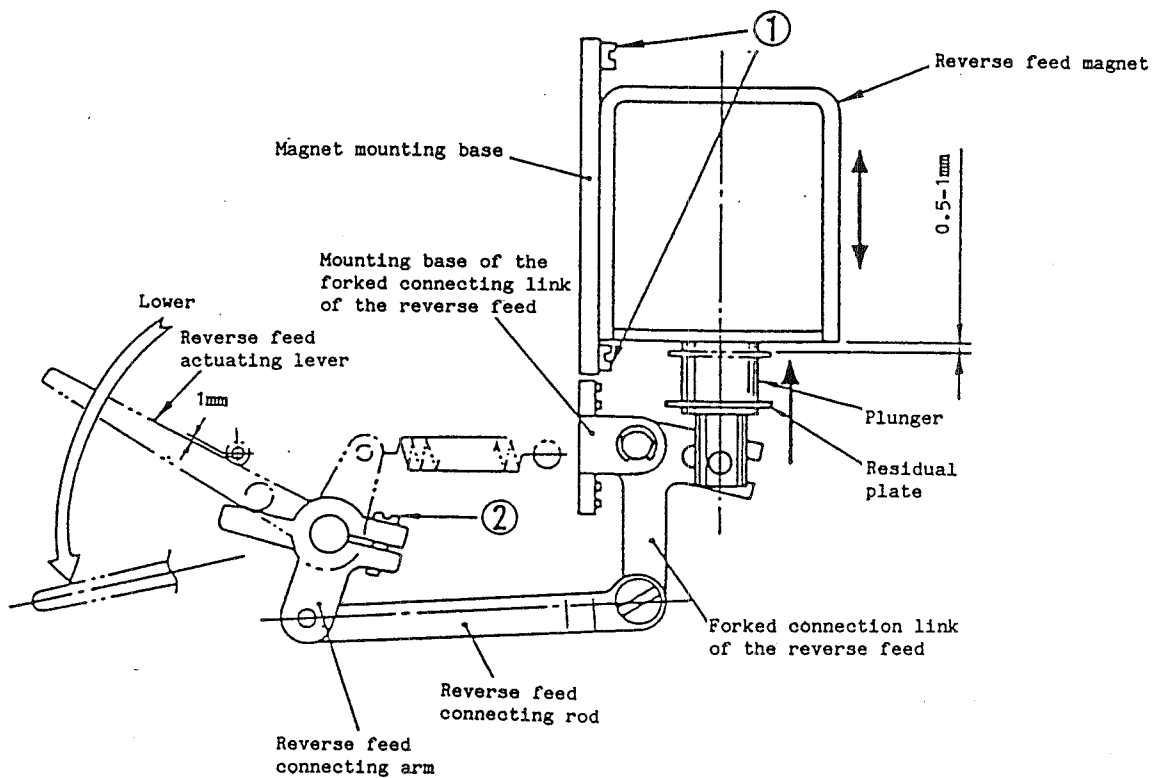

## Conditions

- o Feed amount: Maximum
- o The clearance between the reverse feed magnet and the plunger residual plate is 0.5 to 1 mm when the reverse feed actuating lever is lowered until it will go no further.



HOW TO ADJUST	RESULTS OF IMPROPER ADJUSTMENT
<ol style="list-style-type: none"><li>1. Set the feed regulating dial to its maximum value.</li><li>2. Loosen setscrew ① of the magnet mounting base.</li><li>3. Lower the reverse feed actuating lever until it will go no further, move the magnet mounting base up and down, and adjust so that the clearance between the residual plate attached to the plunger and the inner surface of the reverse feed magnet is 0.5 to 1 mm. Then tighten the setscrew.</li></ol>	<p>If the clearance is too large:</p> <ul style="list-style-type: none"><li>o The magnetic pull will be decreased and the reverse feed mechanism may fail to be actuated.</li></ul> <p>If the clearance is too small:</p> <ul style="list-style-type: none"><li>o The stitch length during reverse feed stitching may be smaller than during normal feed stitching.</li></ul>

4. THREAD TRIMMER COMPONENTS

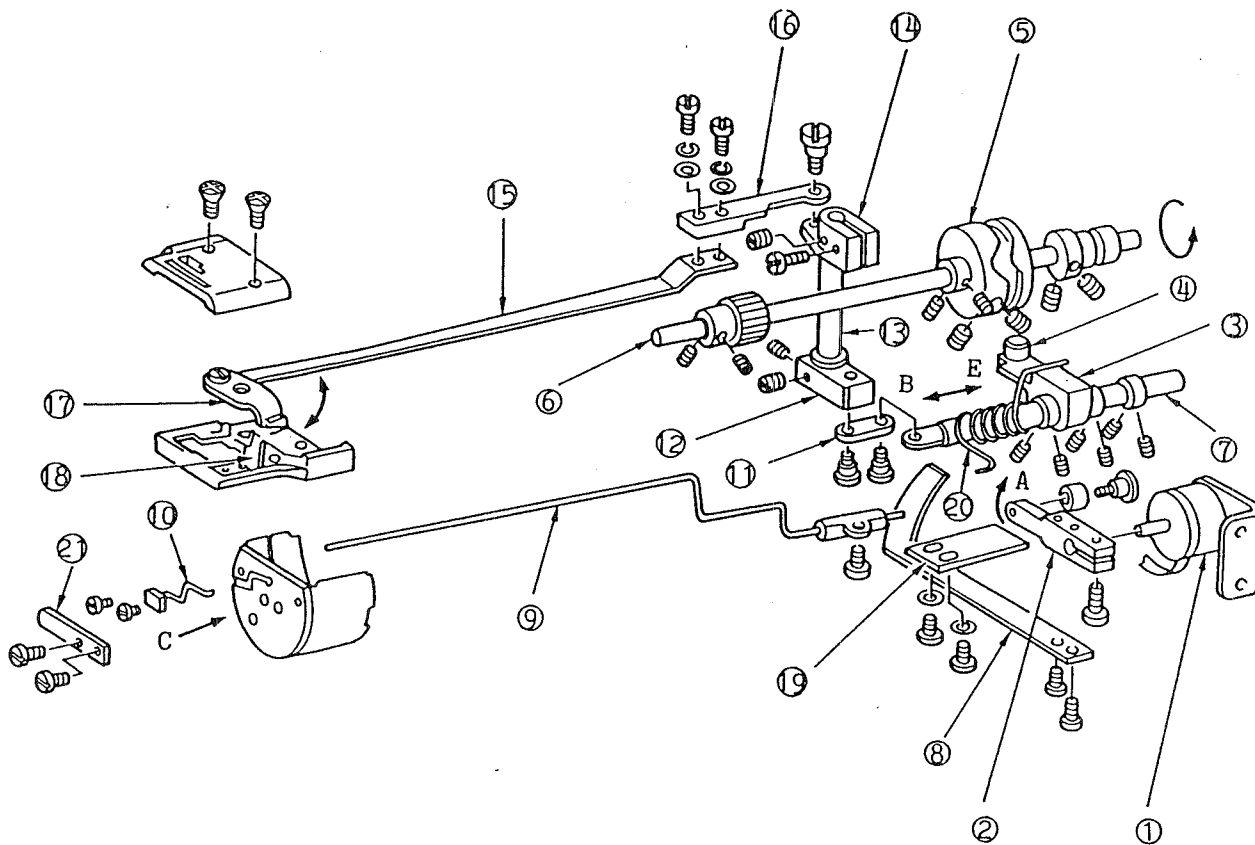

- ① Thread trimmer solenoid
- ② Arm of the thread trimmer solenoid
- ③ Cam roller arm
- ④ Cam roller
- ⑤ Thread trimmer cam
- ⑥ Cam shaft
- ⑦ Thread trimmer driving shaft A
- ⑧ Picker driving plate
- ⑨ Picker driving rod
- ⑩ Picker
- ⑪ connecting link

- ⑫ Thread trimmer driving arm A
- ⑬ Thread trimmer driving shaft B
- ⑭ Thread trimmer driving arm B
- ⑮ Knife driving plate A
- ⑯ Knife driving plate B
- ⑰ Moving knife
- ⑱ Counter knife
- ⑲ Cam roller arm presser
- ⑳ Returning spring
- ㉑ Picker presser leaf spring

1. When thread trimmer solenoid ① is turned on, the arm of the thread trimmer solenoid ② turns in direction A .
2. Along with the rotation of the arm of the thread trimmer solenoid, cam roller arm ③ starts rotating. Cam roller ④ will then engage with thread trimmer cam ⑤ .
3. The rotation of cam shaft ⑥ will move thread trimmer driving shaft A ⑦ in a straight line in direction B by way of the thread trimmer cam.
4. Picker driving plate ⑧ joined to the arm of the thread trimmer solenoid will then turn in direction A .  
The rotation of the picker driving plate will carry picker ⑩ in direction C by way of picker driving rod ⑨ .
5. The straight movement of the picker will oscillate moving knife ⑰ through connecting link ⑪ , thread trimmer driving arm A ⑫ , thread trimmer driving shaft B ⑬ , thread trimmer driving arm B ⑭ , thread trimmer driving plate A ⑮ , and thread trimmer driving plate B ⑯ .
6. If the cam roller enters the inward section of the groove in the thread trimmer cam, each component will move in direction E or F which is the opposite direction of the outward movement. The moving knife and counter knife will then cut the thread.
7. When the cam roller reaches the end of the groove in the thread trimmer cam, the cam roller arm will be released from cam roller arm presser ⑱ . The thread trimmer solenoid will be simultaneously turned off and the cam roller arm will return to its starting position with the force of returning spring ⑳ .
8. If the thread trimmer solenoid is turned off, the picker driving plate will return to its home position, and picker presser leaf spring ㉑ will return the picker to its home position.

Disassembling procedure

(Refer to the configuration of the thread trimmer components and the Parts Book.)

Remove the throat plate.

Remove thread trimmer solenoid ①.

Remove the two setscrews.  
(Do not remove the components joined to the thread trimmer solenoid.)

Remove cam roller arm presser ⑱.

Remove the two setscrews.

Remove connecting link ⑪ from thread trimmer driving shaft A ⑦.

Remove the hinge screw in thread trimmer driving shaft A.

Remove thread trimmer driving shaft B ⑬ from thread trimmer driving arm B ④.

Loosen the setscrew and clamping screw of thread trimmer driving arm B.  
(Thread trimmer driving arm A should not be removed from thread trimmer driving shaft B.)

Remove thread trimmer driving shaft A ⑦.

Loosen the setscrew of the thrust collar.

Remove cam shaft ⑥.

Loosen the setscrew joined to the cam shaft.

## Caution when assembling

→ The moving knife should engage with fitting boss of the throat plate mounting base.

→ Check that the thread trimmer solenoid moves properly. Refer to the "Amount of picker movement".

→ Refer to the "Cam roller arm presser".

→ Check that the thread trimmer driving shaft moves properly.

→ Be sure to fix the setscrew of thread trimmer driving arm B on the contact face of thread trimmer driving shaft B.

→ The initial angle of knife driving arm A should be  $90^\circ$  with regard to knife driving shaft A.

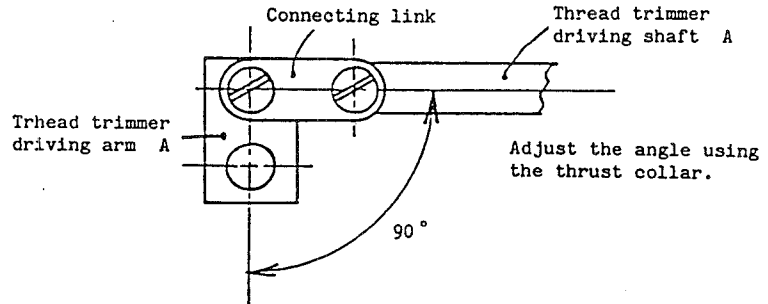

- 
- o Refer to the "Timing of the thread trimmer"
  - o Do not allow any play in the cam shaft.
  - o Position the thread trimmer cam so that the distance from the end face of the hook driving shaft gear to the end face of the cam is 3 mm (use this value as reference).

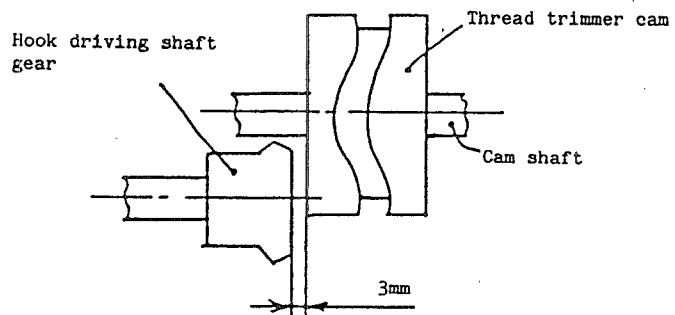

(Caution) Remove the thread trimmer cam after the hook driving shaft has been removed.

## 6. SYNCHRONIZER

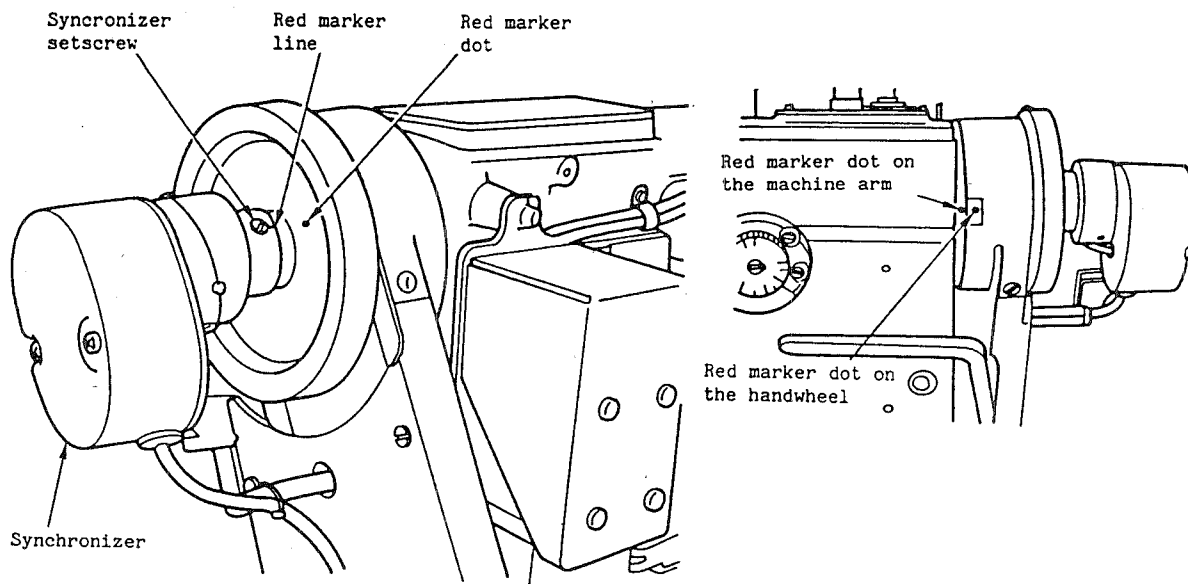

### Condition

- o The red marker dot on the machine arm should be aligned with the red marker dot on the handwheel (when the machine stops with the needle up).

## HOW TO ADJUST

1. Align the red marker dot on the synchronizer with the red marker dot on the boss of the handwheel. Then temporarily fix the synchronizer in place using the setscrew of the synchronizer.
2. Be sure that the machine is stopped with the needle up (to place the material in the sewing position and to thread the needle).
3. Loosen the two screws in the synchronizer rotor and finely adjust so that the red marker dot on the machine arm is aligned with the red marker dot on the handwheel.

## RESULTS OF IMPROPER ADJUSTMENT

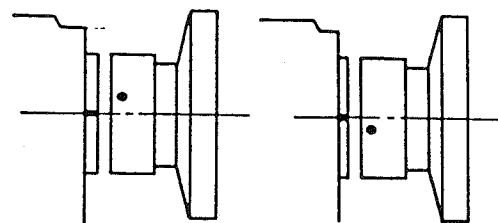

The timing is too early.

The timing is too late.

If the timing of synchronizer actuation is too early:

- o Thread trimming may be faulty.
  - o The cam roller will be unable to disengage from the thread trimmer cam.
- If the timing of synchronizer actuation is significantly early, the moving knife might be actuated resulting in sewing trouble.

If the timing of synchronizer actuation is too late:

- o Thread trimming may be faulty.
- o The position of the needle bar will be lower than normal.

7. LIST OF SELECTABLE PARTS FOR JOINING

Select the appropriate part for joining from the following list.

Part name	Part number	Tolerance
Top and botton feed pin	B163224500A Marker line 1	5.7
	B163224500B	2
	B163224500C	3
	B163224500D	4
	B163224500E	5
Thrust plate of the hook driving shaft	B1839224500A Engraved marker A	1.9
	B183924500B	B
	B183924500C	C
Thrust plate of thread trimmer driving shaft B	B185351200AA Engraved marker A	2.7
	B185351200BA	B
	B185351200CA	C
	B185351200DA	D
	B185351200EA	E
Knife pressure adjusting plate	D2422245000	1 (Standard)
	D242224500A	1.1

8. PARTS TO BE APPLIED WITH LOCK-TITE PAINT

The illustrated components are fixed by applying LOCK-TITE paint. After disassembling any of these components, be sure to clean the section to be applied with LOCK-TITE paint with thinner and then dry the section completely, after which LOCK-TITE paint should be applied and the component assembled.

If a screw fixed by LOCK-TITE paint cannot be removed, heat the screw by means of a torch lamp or the like. This should make it easy to remove the screw.

(Caution)

It is advisable not to disassemble any component which has been applied with LOCK-TITE paint.

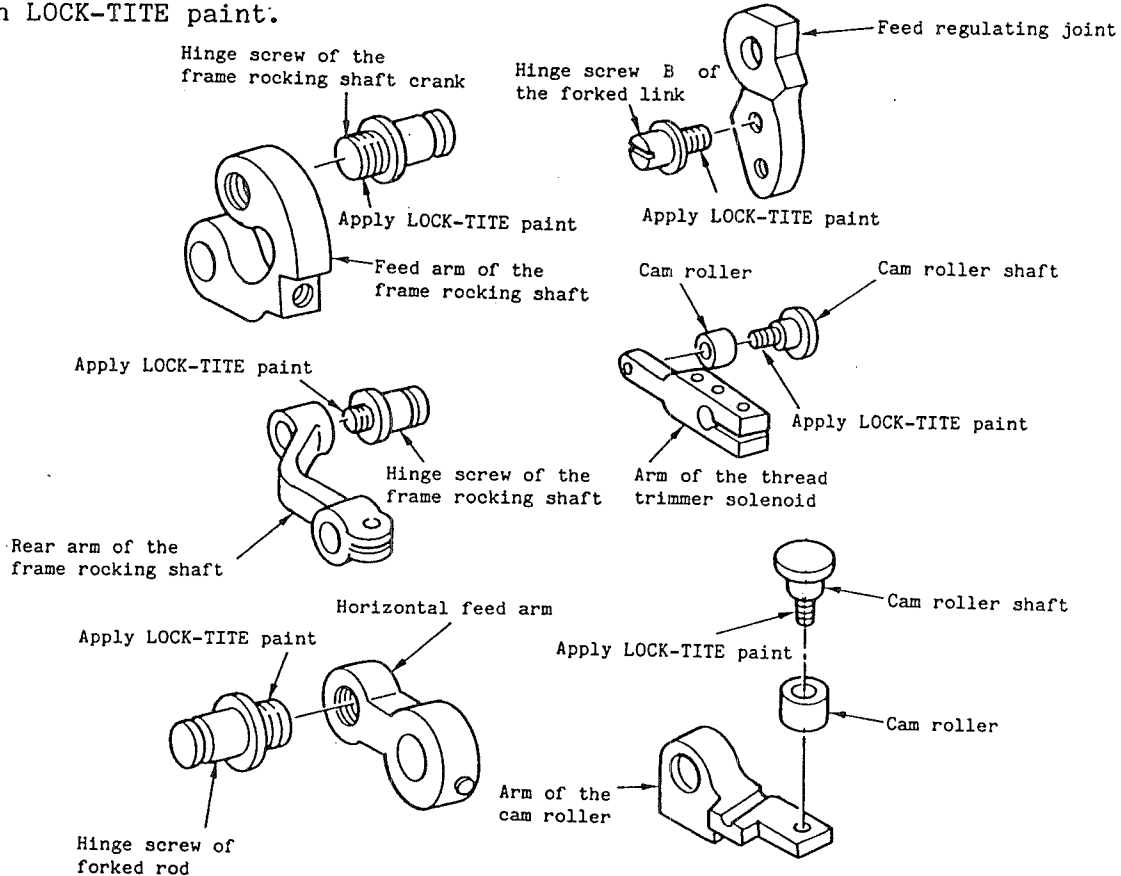



**9. COMPONENTS TO BE APPLIED WITH A SEALING COMPOUND OR ADHESIVE AGENT**

The following parts should be applied with a sealing compound or adhesive agent to prevent an oil leak or to securely fix them in place.

Parts to be applied with a sealing compound or adhesive agent	Sealing compound/ adhesive agent
1. Setscrew of the cylinder cover	Three-bond 1101
2. Setscrew of the rear bushing of the hook driving shaft	"
3. Setscrew of the front, intermediate and rear bushing of the cam shaft	"
4. Setscrew of the front and rear bushing of the thread trimmer driving shaft	"
5. Setscrew of the fixing plate of the thread trimmer solenoid	"
6. Setscrew of the oil level adjusting device (asm.)	"
7. Setscrew of lubrication hole (asm.)	"
8. Oil level adjusting device (asm.)	"
9. Oil level window	"
10. Setscrew of the plunger presser metal fitting	"
11. Setscrew of the thread trimmer solenoid cable	"
12. Bed bracket spacer	Rubber adhesive agent

**10. LIST OF CONSUMABLE PARTS**

Part No.	Part name	Remarks
	Needle (DP x 17)	
B18302450A0	Hook (asm.)	
B18372450A0	Bobbin case (asm.)	Including the idling prevention
B9117012000	Bobbin (without the thread trimmer)	
B911752A00	Aluminum bobbin (with the thread trimmer)	
D2401245E00	Moving knife	
D2402245E00	Counter knife	

## 11. OPTIONAL PARTS

Part No.	Part name	Remarks
B147024500	Walking foot	For bottom sewing
B152424500A	Presser foot	Supplied with the unit
B152424500B	Presser foot	For bottom sewing
B161324500A	Feed (for fabric) (without the thread trimmer)	Without a groove
B161324500B	Feed (for a thin needle) (without the thread trimmer)	Without a groove
D1613245E0A	Feed (for fabric) (without the thread trimmer)	Without a groove
D1613245E0B	Feed (for a thin needle) (without the thread trimmer)	Without a groove

## 12. TAPE SEWING ATTACHEMENT

- (1) Model: DSC-245/Q092 (tape guide for a narrow tape)  
 DSC-245/Q093 (tape guide for a wide tape)  
 DSC-245-5/Q094 (tape guide for a narrow tape)  
 DSC-245-5/Q095 (tape guide for a wide tape)

### (2) How to select the attachment

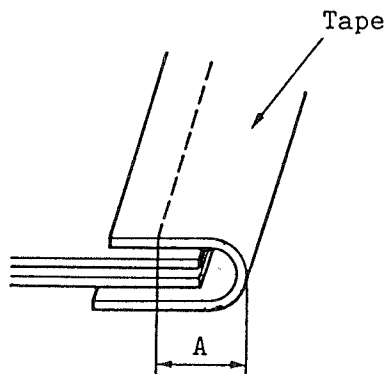

If the binding width (distance A in the figure) is 5 mm or less, select the Q092 or Q094 tape guide for a narrow tape.

If the binding width is 5 mm or more, select the Q093 or Q095 tape guide for a wide tape.

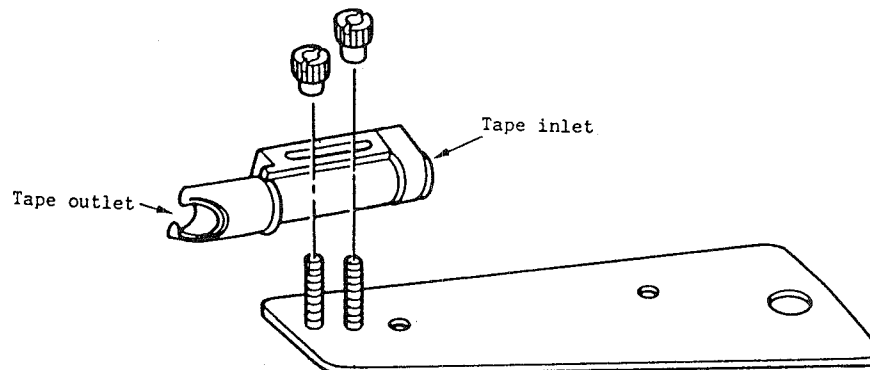

### (Caution)

The type of binder depends on the thickness and width of tape to be used. The binders are therefore made to order and are not supplied with the Q092, Q093, Q094 or Q095 tape guides.

### (3) Replacing the elliptical feed with the horizontal feed

Removal procedure for the elliptical feed

- 1) Remove presser foot ① and walking foot ②.
- 2) Loosen setscrews ③ of the throat plate and remove throat plate ④.
- 3) Loosen setscrew ⑤ of the top face cover of the bed and screw ⑥ of the cover of the feed bracket shaft. Remove bed top face cover ⑦, spring ⑧ of the bed top face cover, and cover ⑨ of the feed bracket shaft.
- 4) Remove the spring support shaft.
- 5) Remove feed bracket ⑪. (Remove the feed bracket with feed ⑫, feed bracket block shaft ⑬ and the other components mounted.)
- 6) Remove feed setscrews ⑭ and remove feed ⑫ from feed bracket ⑪.
- 7) Remove E-ring ⑮ and remove feed bracket block B ⑯ from feed bracket block shaft ⑬.
- 8) Loosen feed bracket block shaft ⑬ and remove it from feed bracket ⑪.
- 9) Remove feed bracket block A ⑰ from feed rocker ⑱.  
(Do not remove feed rocker ⑱.)
- 10) Remove top and bottom feed pin ⑲.

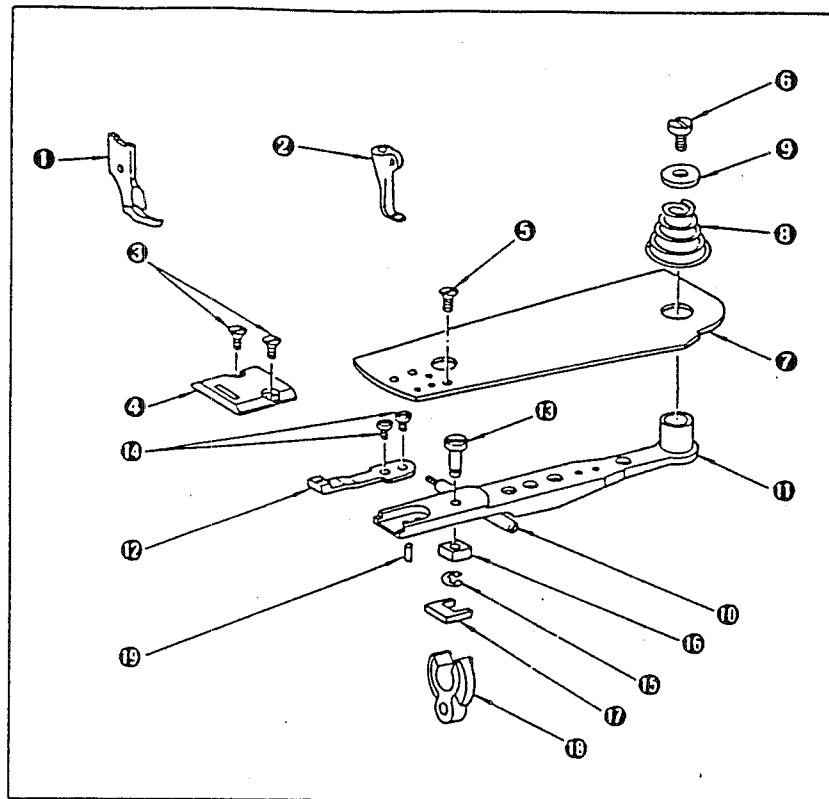

Mark	No.	Part No.	Part name	Q'ty	Remarks
	1	B1524245000	Presser foot	1	
	2	B1470245000	Walking foot	1	
	3	SS2110915SP	Throat plate setscrews	2	11/64 thread ridge 40, L=8.5
	4	B1105245000	Throat plate	1	
*		D1105245E00	Throat plate	1	
	5	SS2090710SP	Setscrew of the bed top face cover	1	9/64 thread ridge 40, L=7
★	6	B1653245000	Screw of the feed bracket cover	1	9/64 thread ridge 40, L=10
	7	B1173245000	Bed top face cover	1	
*		D1173245E00	Bed top face cover	1	
	8	B1175245000	Spring of the bed top face cover	1	
★	9	B1640245000	Feed bracket shaft cover	1	
★	10	B1638245000	Spring support shaft	1	
★	11	B1606245000	Feed bracket	1	
*		D1606245E00	Feed bracket	1	
	12	B1613245000	Feed	1	
*		D1613245E00	Feed	1	
	13	B1645245000	Feed bracket block shaft	1	
★	14	B1652245000	Feed setscrews	2	1/8 thread ridge 44, L=3.7
	15	RE0300000K0	E-ring	1	
	16	B1644245000	Feed bracket block B	1	
	17	B1643245000	Feed bracket block A	1	
★	18	B1603245000	Feed rocker arm	1	
	19	B163224500C	Top and bottom feed pin	1	

- (Note) 1. The parts marked with a star (★) are used after making a replacement.
2. The parts marked with an asterisk (\*) are exclusive for the DSC-245-4 or -5 models.

#### Installation procedure for the horizontal feed

- 1) Attach feed bracket block (20) to feed rocker (16).
- 2) Attach feed bracket block shaft (21) to feed bracket (11).
- 3) Temporarily fix feed (22) to feed bracket (11).
- 4) Install feed bracket (11) attached to feed bracket block shaft (21) and feed (22).
- 5) Attach spring support shaft (10).
- 6) Fix the feed (22) so that the needle enters the center of the needle hole in the feed.
- 7) Tighten binder setscrews (24) in bed top face cover (23). Then apply an adhesive agent to setscrews (24) and firmly tighten them.
- 8) Fit setscrew nuts (25) on to setscrews (24).
- 9) Install tape guide (26) on the bed top face cover (23) using setscrew (27).
- 10) Upon completion of steps 7), 8) and 9), attach bed top face cover (23).
- 11) Fit spring (28) of the bed top face cover and feed bracket shaft cover (9). Then tighten screw (6) of the feed bracket shaft cover.
- 12) Install throat plate (29) and fix it in place with throat plate setscrews (30).
- 13) Attach presser foot (31) and walking foot (32).

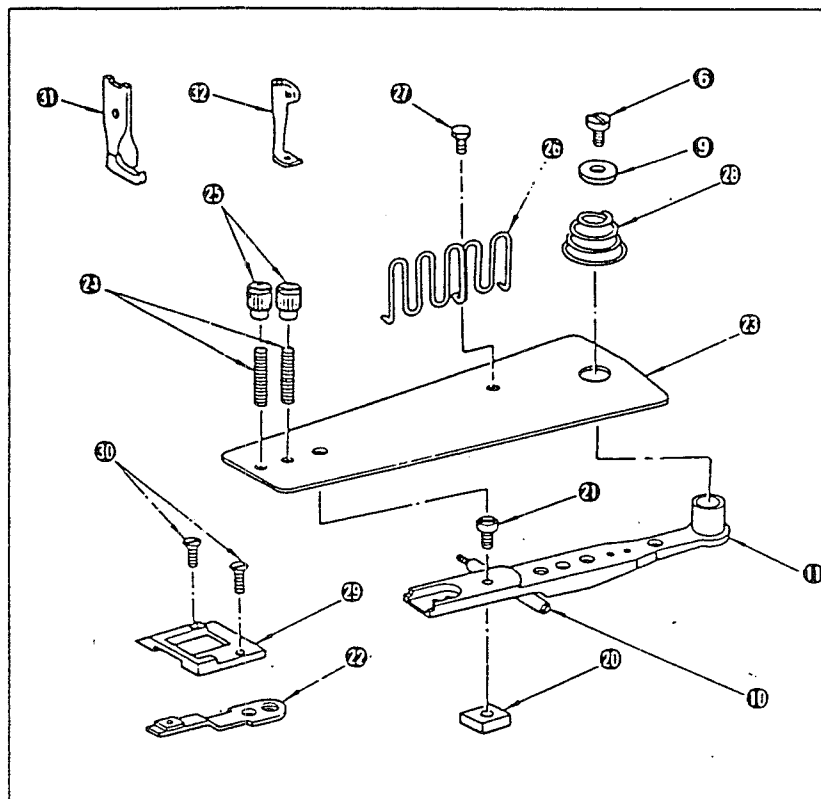

List of parts to be replaced

Mark	No.	Part No.	Part name	Q'ty	Remarks
	20	MAQ09210000	Feed bracket block	1	
	21	MAQ09211000	Feed bracket block shaft	1	
*		MAQ09411000	Feed bracket block shaft	1	
	22	MAQ09209000	Feed	1	To attach a narrow tape
		MAQ09309000	Feed	1	To attach a wide tape
*		MAQ09409000	Feed	1	To attach a narrow tape
*		MAQ09509000	Feed	1	To attach a wide tape
	23	MAQ09202000	Bed top face cover	1	
*		MAQ09402000	Bed top face cover	1	
	24	MAQ09204000	Binder setscrews	2	11/64 thread ridge 40
	25	MAQ09205000	Binder setscrew nuts	2	11/64 thread ridge 40
	26	MAQ09206000	Tape guide	1	
	27	SS7110510SP	Tape guide setscrew	1	11/64 thread ridge 40, L=5
	28	MAQ09203000	Spring of the bed top face cover	1	
	29	MAQ09201000	Throat plate	1	
*		MAQ09401000	Throat plate	1	
	30	SS2110930SP	Throat plate setscrews	2	11/64 thread ridge 40, L=8.5
	31	MAQ09208000	Presser foot	1	To attach a narrow tape
		MAW09308000	Presser foot	1	To attach a wide tape
	32	MAQ09207000	Walking foot	1	To attach a narrow tape
		MAQ09307000	Walking foot	1	To attach a wide tape

(Note) 1. The parts marked with an asterisk (\*) are exclusive for the DSC-245-4 and -5 models.

2. Select the feed, presser foot and walking foot as a whole set in accordance with the width of tape to be used.

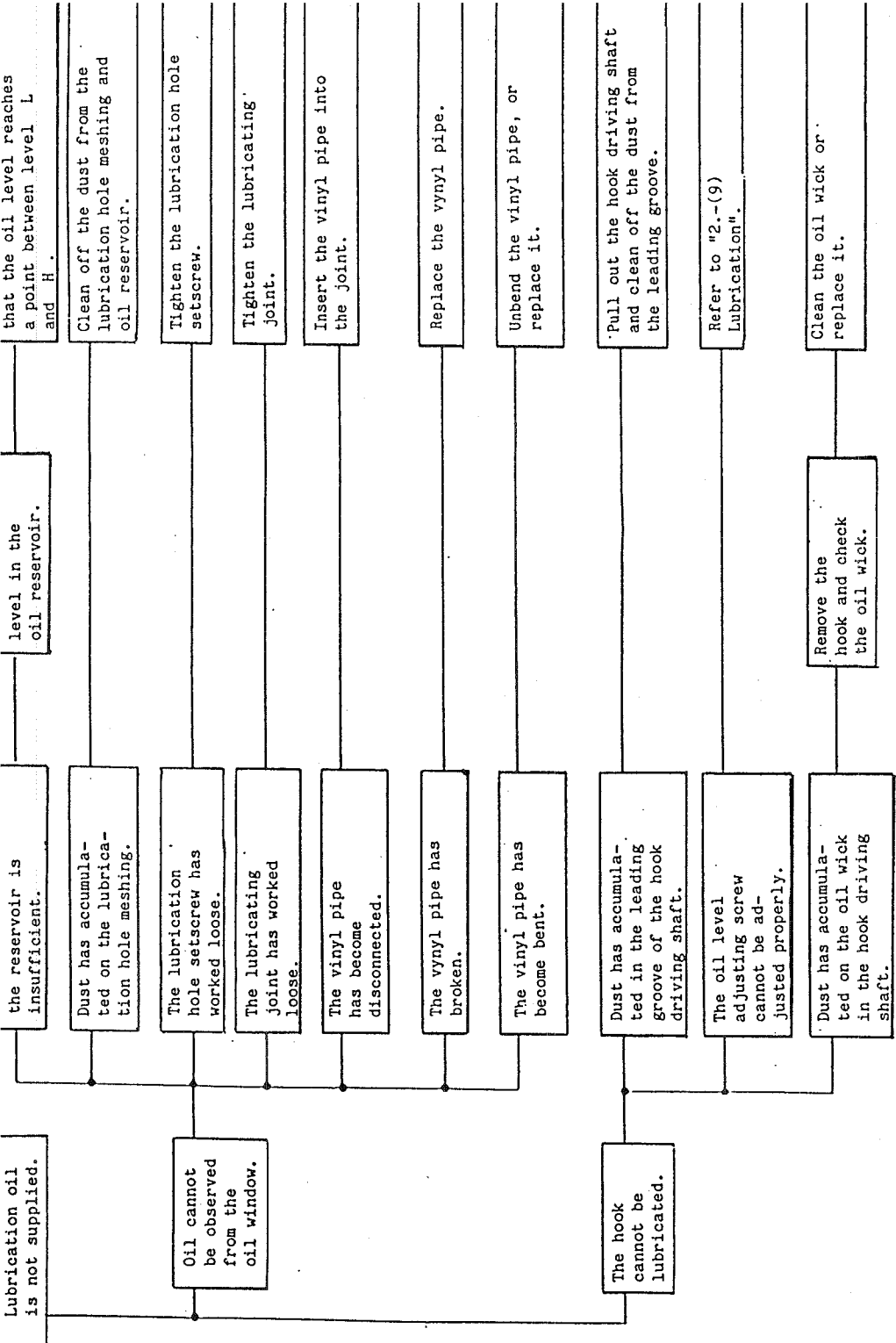

Lubrication oil is not supplied.

the reservoir is insufficient.

level in the oil reservoir.

that the oil level reaches a point between level L and H.

Dust has accumulated on the lubrication hole meshing.

Clean off the dust from the lubrication hole meshing and oil reservoir.

Oil cannot be observed from the oil window.

The lubrication hole setscrew has worked loose.

Tighten the lubrication hole setscrew.

The lubricating joint has worked loose.

Tighten the lubricating joint.

The vinyl pipe has become disconnected.

Insert the vinyl pipe into the joint.

The vinyl pipe has broken.

Replace the vinyl pipe.

The vinyl pipe has become bent.

Unbend the vinyl pipe, or replace it.

The hook cannot be lubricated.

Dust has accumulated in the leading groove of the hook driving shaft.

Pull out the hook driving shaft and clean off the dust from the leading groove.

The oil level adjusting screw cannot be adjusted properly.

Refer to "2.-(9) Lubrication".

Dust has accumulated on the oil wick in the hook driving shaft.

Remove the hook and check the oil wick.

Clean the oil wick or replace it.

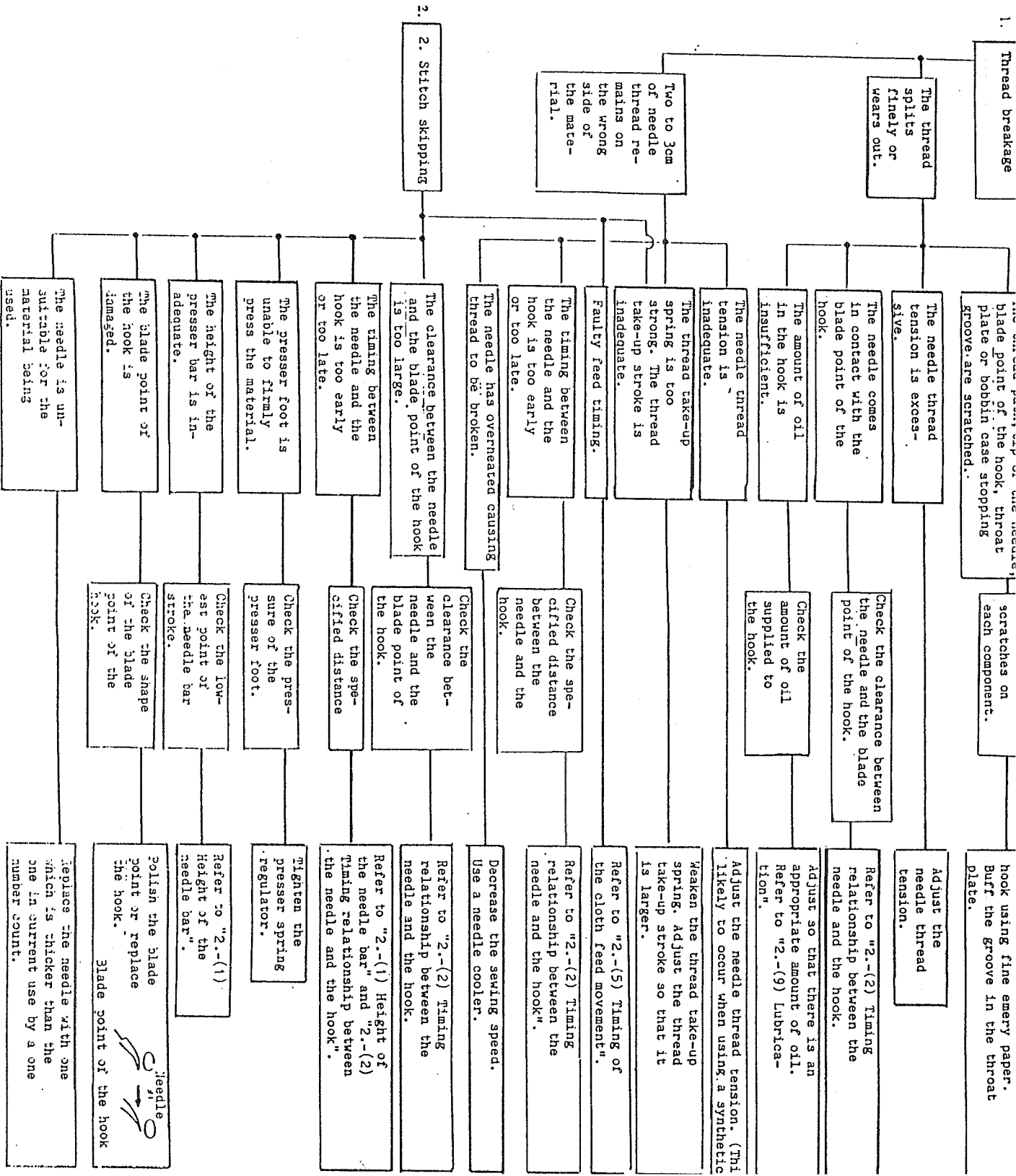

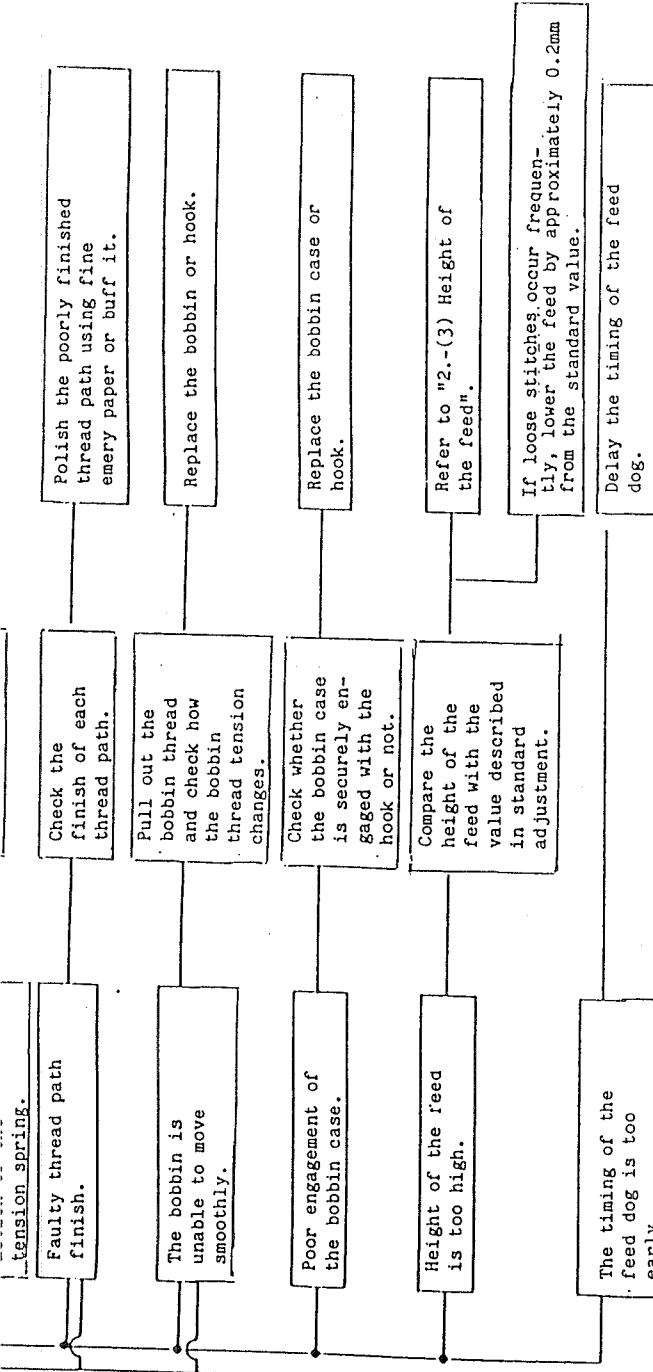

4. Irregular stitches

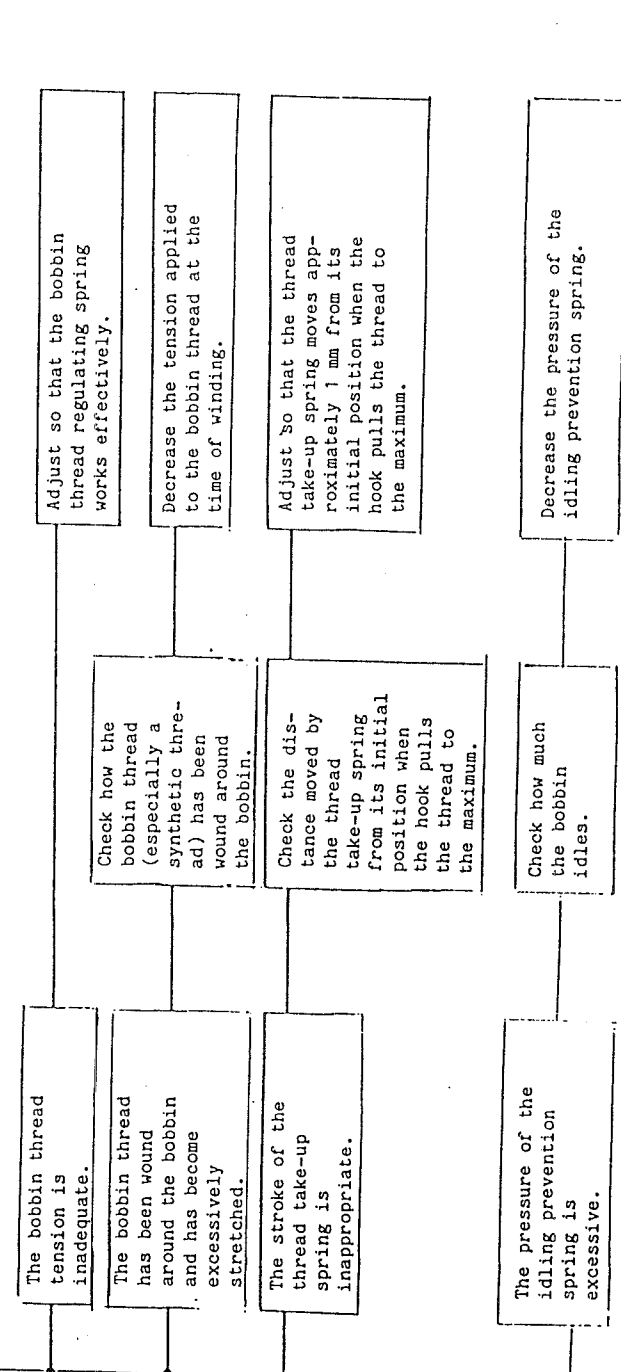



Automatic thread trimming

1. Immediately after the thread has been trimmed, the needle thread slips off the needle eyelet.

Thread tension No. 1 has been adjusted so that it has become excessively strong.

The thread trimmer is actuated too early.

The thread tension disk is unable to float properly.

The needle thread is trimmed twice (double-cutting).

The amount of picker movement is insufficient.

Check thread tension No.

Check the position of the marker engraved on handwheel.

Check how the thread tension disk floats.

Approx. 30% thread may wound around the hook.

Check the amount of picker movement.

off the needle  
eyelet at the  
sewing start.

too short.

Thread tension No. 1 has been adjusted so that it has become excessively strong.

Check thread tension No. 1.

Decrease the tension of thread tension No. 1.

The thread tension disk is unable to float properly.

Check how high the thread tension disk floats.

Increase the floating amount of the disk.

The thread trimmer is actuated too early.

Check the position of the cam with regard to the marker dot engraved on the handwheel.

Refer to "3.-(1)-1) Timing of the thread trimmer".

The thread slips off the needle eyelet as a result of the return movement of the thread take-up spring after the thread trimming knife has dropped and cut the thread.

Check whether the thread being used is a thin type of thread (including tetron thread or nylon thread).

If the above type of thread is being used, replace the thread guide with the thread guide supplied with the unit.

The bobbin thread tension is inadequate.

Increase the bobbin thread tension.

The machine stops before the needle bar reaches its highest position.

Check whether the travelling distance of the thread take-up from its position at the time when the sewing machine stops to the highest position of its stroke is large.

Refer to "6. Synchronizer".

The bobbin idles too much.

Check the thread trimming speed. Check that an aluminum bobbin is being used.

Decrease the thread trimming speed. Use an aluminum bobbin.

3. A seam cannot be formed after several stitches have been sewn at the sewing start.

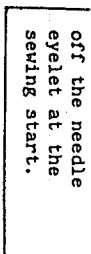

7. Locks.)

float suitably.

floats.

The thread trimming speed is too slow.

Check the thread speed.

The motor torque is excessive.

Check the thread engagement the trimmer elements.

The pressure applied to the knife is excessive.

Check the blades moving and course knife.

The knives are unable to cut well.

The thread is unable to come out with correct timing.

The mach stops will needle based close the high dead point stroke

Automatic reverse feed/Manual reverse feed

1. The number of finished stitches is different from that specified before the start of sewing.

The related components come in contact with each other.

Check the components through the feed adjustment.

The plunger stroke is too great.

Check the clearance 0.5 to 1

2. The normal feed stitch length and the reverse feed stitch length are not appropriately matched.

The position of the feed regulating screw bushing is incorrect.

Check the static length.

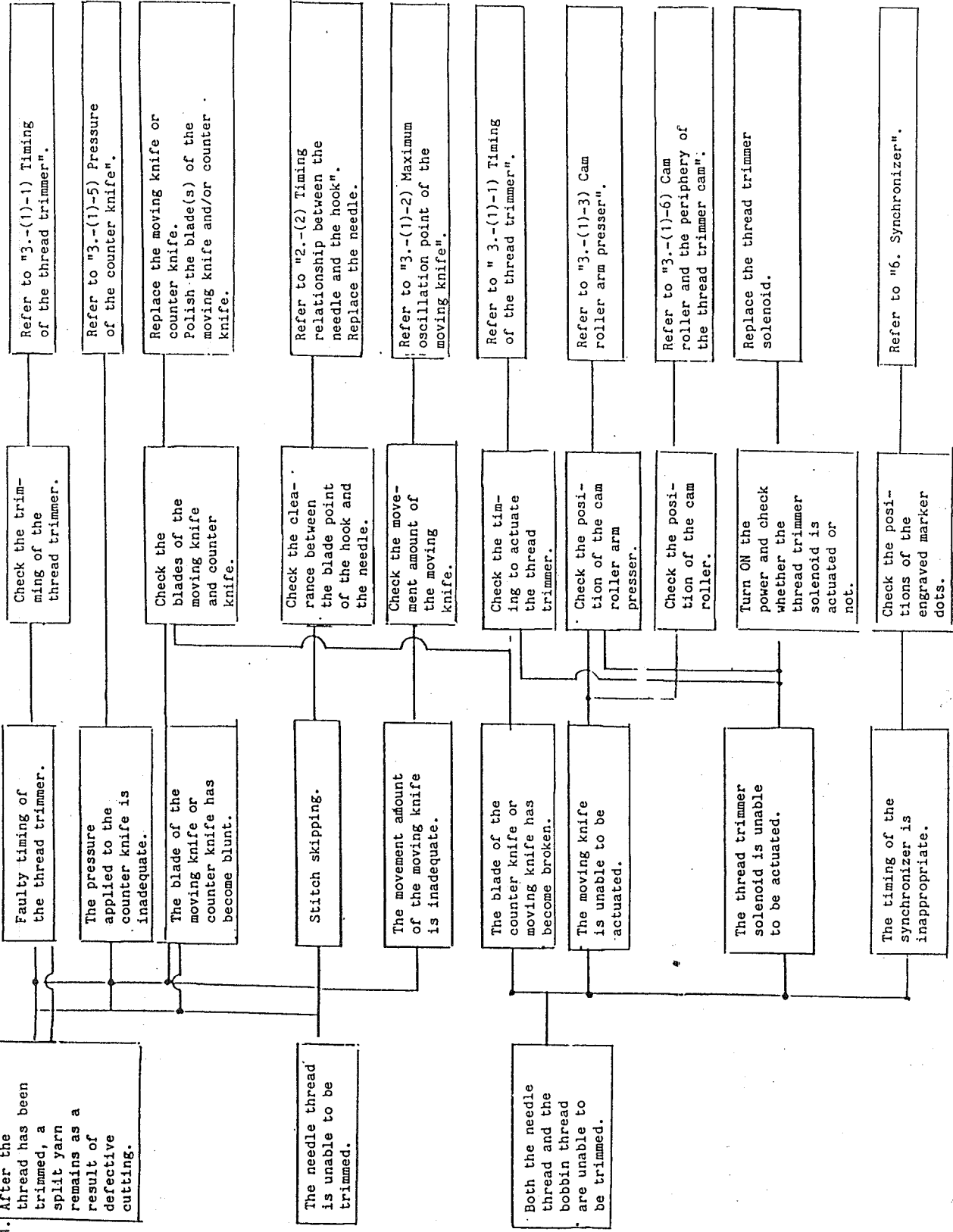

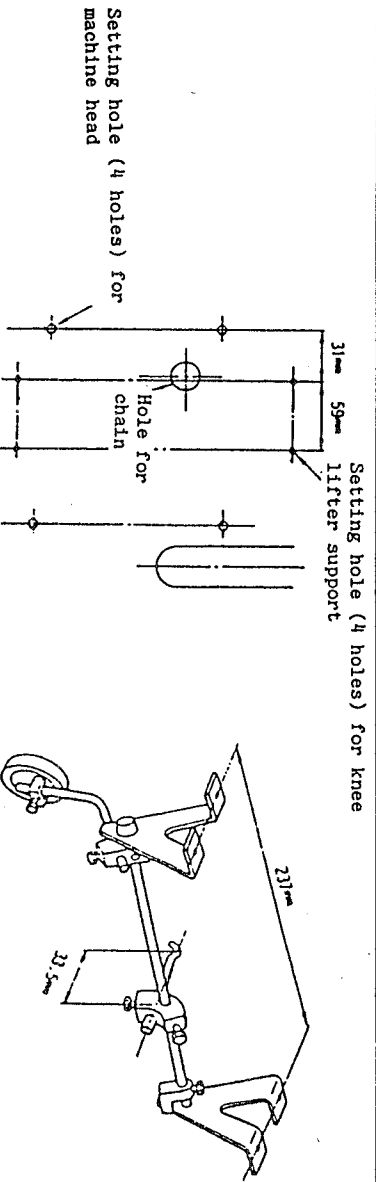
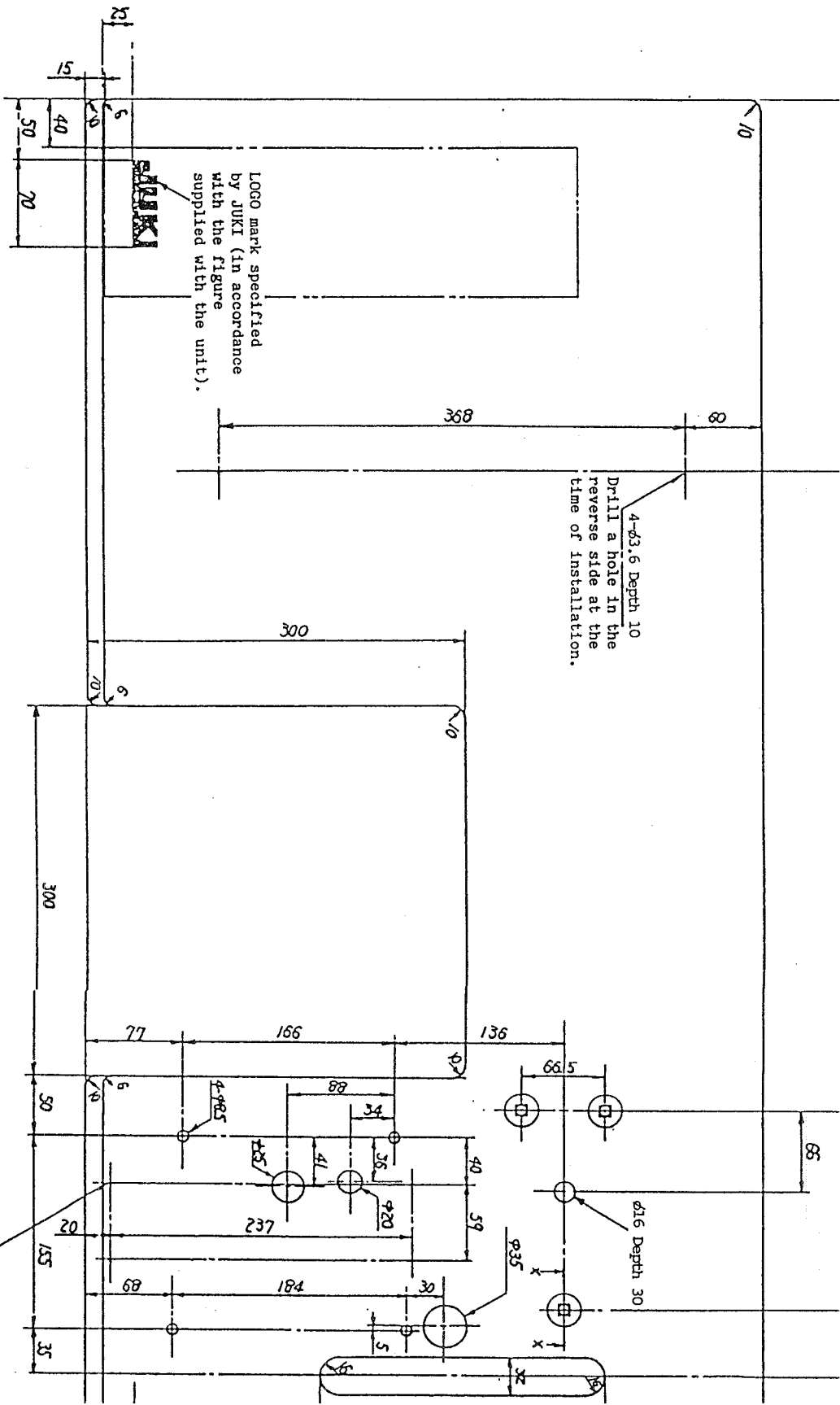

17. DIAGRAM OF THE 1

(Caution) Be sure to install the knee lifter prior to the motor.

16. INSTALLATION DIAGRAM OF KNEE LIFTER