

1. SPECIFICATIONS

< APW-297 >

(1) MECAHNICAL SPECIFICATIONS

- 1) Sewing machine : LH-597 model of 2-needle, lockstitch machine with a center knife (exclusively used for APW)
- 2) Sewing speed : 3,000 rpm (max.)
- 3) Stitch length : Lockstitch : 2.0 to 3.4 mm (standard: 2.5mm)
Condensation stitch : 0.5 to 1.5 mm (standard : 1.0 mm)
Back tack stitch : 0.5 to 3.4 mm (Standard : 2.0 mm)
Condensation/Back tack stitch selectable
- 4) Types of welt : Parallel double welt, parallel single welt } Each with flap or without flap
- 5) Pocket lip length : Possible to set in increments of 1 mm within the range of 18 mm (min.) to 180 mm (max.)
(Welt length)
Note that the pocket lip length is 25 mm at the minimum when using the corner knife.
For the longer type (option), the maximum sewing length will be 220 mm.
- 6) Welting width : 10, 12 and 14 mm
(needle gauge)
- 7) Needles : ORGAN Mt x 190 #16 to #18 (standard #16)
SCHMETZ 190R #100 to #110 (standard #100)
- 8) Thread : Spun thread #50 (Recommended)
- 9) Hook : Full rotary, vertical-axis, self-lubrication hook
- 10) Thread take-up lever : Slide thread take-up lever
- 11) Needle bar stroke : 34.4 mm
- 12) Cloth feed mechanism: Driven by servomotor
- 13) Control : By a micro-computer
- 14) Safety mechanism : Machine operation is automatically stopped if the cloth feed mechanism error detector and, the needle thread breakage detector or any of the various safety devices are actuated.
- 15) Lubricating oil : JUKI New Defrix Oil No.2
- 16) Operating air pressure : 0.5 MPa
- 17) Air consumption : Approx. 40 Nℓ /min.
- 18) Dimensions of the machine: 980 mm (width) x 1,650 mm (length) x 1,200 mm (height)
(1,580 mm – when including the stacker)
(1,500 mm – when including the thread stand)
- 19) Weight : Approx. 380 kg

(2) ELECTRICAL SPECIFICATIONS

Once the required data is set by means of a built-in micro-computer, the data can be stored in memory (for 100 hours) using a built-in battery even after turning OFF the power to the machine unless the setting is canceled. In addition, the stored data can be output to a personal computer and saved by making use of the exclusive circuit board. Further, these data can be copied to the other machines. Consult our JUKI service man if necessary.

- 1) The number of patterns that can be stored in memory : 100 (0 - 99)
- 2) The number of cycles that can be stored in memory : 10 (0 - 9)
- 3) Input power : Single-phase / 3-phase : 200, 220, 230, 240, 380, 400, 415 50/60 Hz
Voltage fluctuation : Within $\pm 10\%$ of the rated voltage
- 4) Power consumption : 550 W

Noise : Workplace-related noise at sewing speed

n = 3000 min⁻¹ : LPA 83 dB(A)

Noise measurement according to DIN 45635-48-B-1.

< APW-298 >

(1) MECAHNICAL SPECIFICATIONS

- 1) Sewing machine : LH-598 model of 2-needle, lockstitch machine with a center knife and a needle stop mechanism (exclusively used for APW)
- 2) Sewing speed : 3,000 rpm (max.)
- 3) Stitch length : Lockstitch: 2.0 to 3.4 mm (standard: 2.5mm)
Condensation stitch : 0.5 to 1.5 mm (Standard : 1.0 mm)
Back tack stitch : 0.5 to 3.4 mm (Standard : 2.0 mm)
Condensation/Back tack stitch selectable
- 4) Types of welt : Parallel double welt, parallel single welt, } Each with flap or without flap
slant double welt, slant single welt, }
trapezoidal stitching }
- 5) Pocket lip length : Possible to set in increments of 1 mm within the range of 18 mm (min.) to
(Welt length) 180 mm (max.)
Note that the pocket lip length is 25 mm at the minimum when using the corner knife.
For the longer type (option), the maximum sewing length will be 220 mm.
- 6) Welting width : 10, 12 and 14 mm
(needle gauge)
- 7) Needles : ORGAN DP × 17 #16 to #18 (standard #16)
SCHMETZ SY3355 #100 to #110 (standard #100)
- 8) Thread : Spun thread #50 (Recommended)
- 9) Hook : Full rotary, vertical-axis, self-lubrication hook
- 10) Thread take-up lever : Slide thread take-up lever
- 11) Needle bar stroke : 33.36 mm
- 12) Cloth feed mechanism : Driven by servomotor
- 13) Control : By a micro-computer
- 14) Safety mechanism : Machine operation is automatically stopped if the cloth feed mechanism error detector and, the needle thread breakage detector or any of the various safety devices are actuated.
- 15) Lubricating oil : JUKI New Defrix Oil No.2
- 16) Operating air pressure : 0.5 MPa
- 17) Air consumption : Approx. 40 Nℓ /min.
- 18) Dimensions of the machine : 980 mm (width) × 1,650 mm (length) × 1,200 mm (height)
(1,580 mm – when including the stacker)
(1,500 mm – when including the thread stand)
- 19) Weight : Approx. 380 kg

(2) ELECTRICAL SPECIFICATIONS

Once the required data is set by means of a built-in micro-computer, the data can be stored in memory (for 100 hours) using a built-in battery even after turning OFF the power to the machine unless the setting is canceled. In addition, the stored data can be output to a personal computer and saved by making use of the exclusive circuit board. Further, these data can be copied to the other machines. Consult our JUKI service man if necessary.

- 1) The number of patterns that can be stored in memory : 100 (0 - 99)
- 2) The number of cycles that can be stored in memory : 10 (0 - 9)
- 3) Input power : Single-phase / 3-phase : 200, 220, 230, 240, 380, 400, 415 50/60 Hz
Voltage fluctuation : Within ± 10% of the rated voltage
- 4) Power consumption : 550 W

Noise: Workplace-related noise at sewing speed

n = 3000 min⁻¹ : L_{PA} 83 dB(A)

Noise measurement according to DIN 45635-48-B-1.

2. NAMES OF COMPONENTS

The machine consists mainly of the following units;

- Ⓐ Frame and structural components
(Frame, sewing table, covers, foot switch etc.)
- Ⓑ Clamp foot unit and feed mechanism
- Ⓒ Corner knife unit
- Ⓓ Binder unit (Binder components and its driving components)
- Ⓔ Pneumatic control unit (Pneumatic control devices and pipings)
- Ⓕ Stacker unit
- Ⓖ Sewing machine head
- Ⓗ Electric control unit (Control panel)
- Ⓘ Oil pan
- ⓵ Operation panel
- ⓶ Power switch

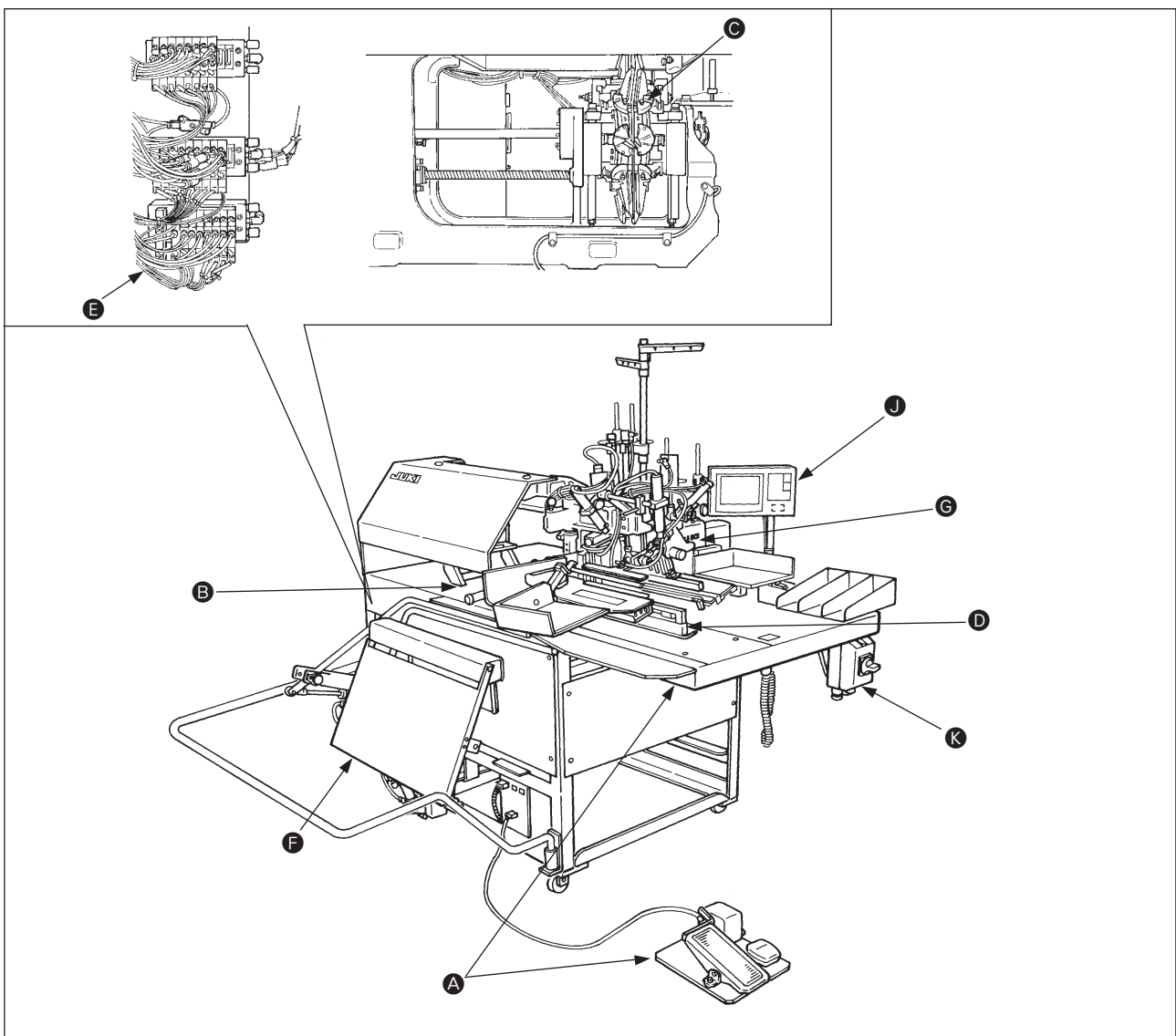

With this machine, you can do desired welting work simply by setting materials (garment body, interlining piece, welting patch etc.) in place and operating the switches on the operation panel.

3. STANDARD ADJUSTMENTS

(1) Machine head components

1) Main shaft components

Standard Adjustment

① Adjusting the main shaft origin sensor

This sewing machine detects the upper dead point of the needle bar with the main shaft origin sensor ❶ mounted inside the machine and makes the point the origin to control the revolution of the sewing machine.

... When the power is turned ON, the sewing machine performs the operation of the main shaft origin retrieval and stops at the upper dead point of the thread take-up lever. In a case where the machine does not stop at the upper dead point when the machine is turned by hand pulley or the like, an alarm (AL-12 : needle UP trouble) is displayed when the MACHINE READY key is pressed. In this case, the machine automatically returns to the upper dead point of the thread take-up lever by pressing the RESET key.

(State to perform sewing is obtained.)

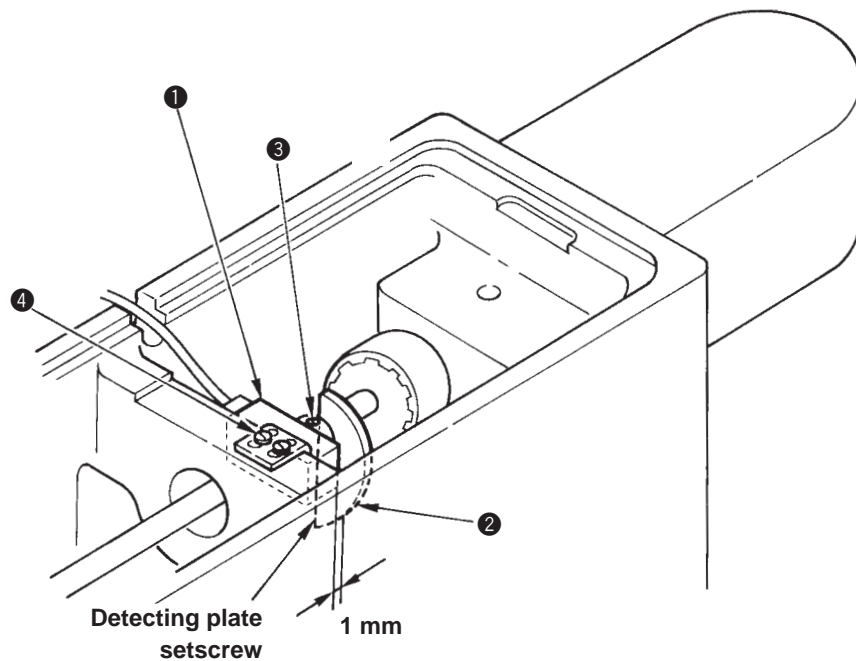

Adjustment Procedures	Results of Improper Adjustment
<ol style="list-style-type: none"> 1) Turn OFF the power to the machine. 2) Loosen the setscrew and remove the top cover (lid located on the top surface of the sewing machine). 3) Turn and stop the sewing machine by hand at the lower dead point of the needle bar. 4) Loosen two collar setscrews ③ and adjust so that detecting plate ② is on the operator's side and the edge is vertical. Remove the cap located on the back of the machine head and enter a screwdriver to loosen one of the setscrews. 5) A clearance of 0.5 to 1.5 mm between the detecting plate and the sensor is the standard adjustment value. If the clearance is not within the specified value, loosen main shaft origin sensor setscrew ④ to adjust the clearance. 6) When the aforementioned adjustment is completed, attach the top cover in place and turn ON the power. <ul style="list-style-type: none"> The adjustment is proper when the sewing machine stops at the upper dead point of the needle bar. 	<ul style="list-style-type: none"> ○ When the main shaft origin sensor and the detecting plate are not properly adjusted, the sewing machine does not stop at the upper dead point of the thread take-up lever. ○ In case of APW-297, stopping height of the needle bar (needle tip is 11.5 mm away from the throat plate) is not within the specified value, and thread breakage at the start of sewing may occur.

Standard Adjustment

② Replacing the timing belt

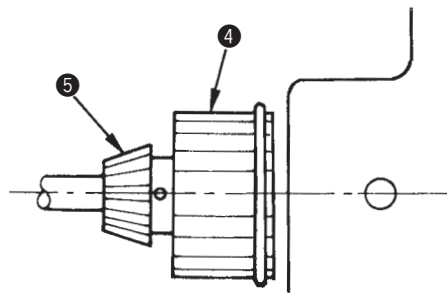
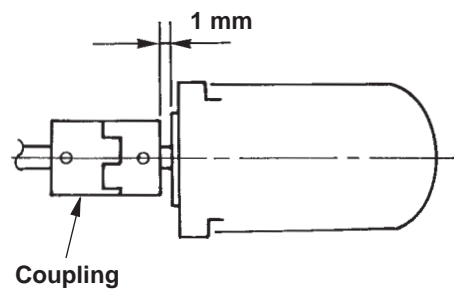
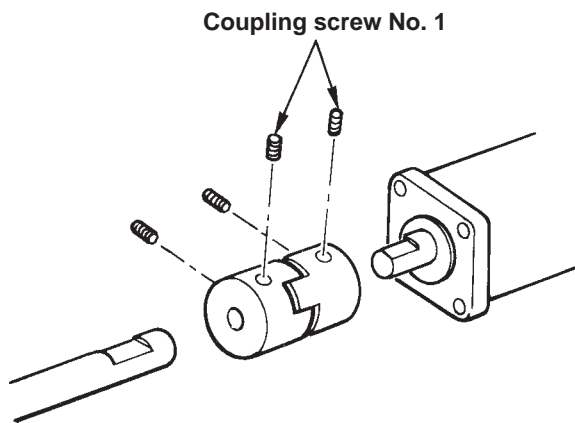
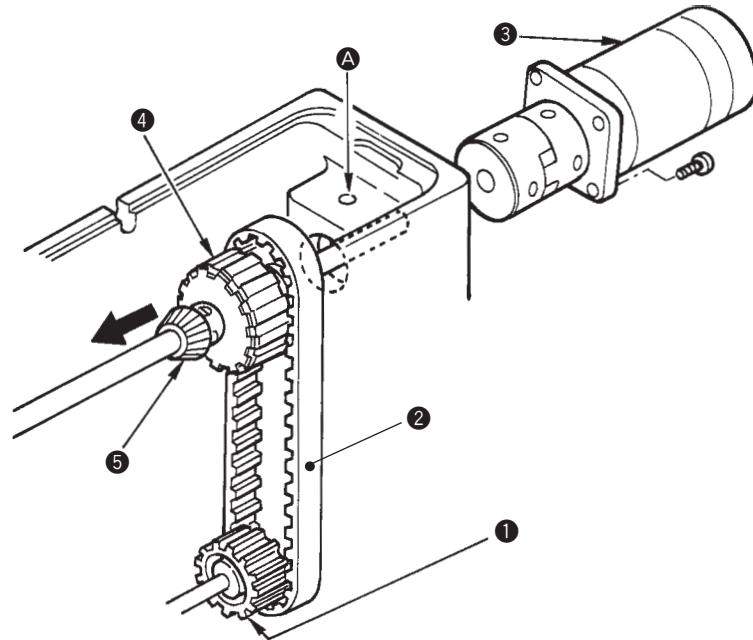

Adjustment Procedures	Results of Improper Adjustment
<p>1) Remove the top cover (lid located on the top surface of the sewing machine).</p> <p>2) Remove timing belt ② from lower sprocket wheel ①.</p> <p>3) Enter a hexagonal wrenck key from section A and loosen two coupling setscrews.</p> <p>4) Loosen the setscrews and remove main shaft motor ③.</p> <p>5) Loosen the setscrews in the upper sprocket wheel asm.</p> <p>6) Loosen the setscrews in the hand pulley gear B.</p> <p>7) Pull out the upper sprocket wheel asm ④. Upper sprocket wheel asm. ④ is pressed in the machine arm. Tap the wheel from the inside of the hole and pull it out toward the left-hand side (←).</p> <p>8) Pull out the timing belt through the hole.</p> <p>9) Enter a new timing belt and assemble it the same as before. At this time, be careful of the following matters.</p> <ul style="list-style-type: none"> * When pressing upper sprocket wheel asm. ④ in the machine arm, apply the bearing mount (LOCKTITE : 085 for medium strength fit) to the wheel. * The flat sections of both the main shaft and the motor shaft become the positions of the coupling screws No. 1. * Make hand pulley gear B ⑤ come in contact with the upper sprocket wheel asm ④. 	

2) Needle bar components

Standard Adjustment

① Adjusting the height of the needle bar (APW-297)

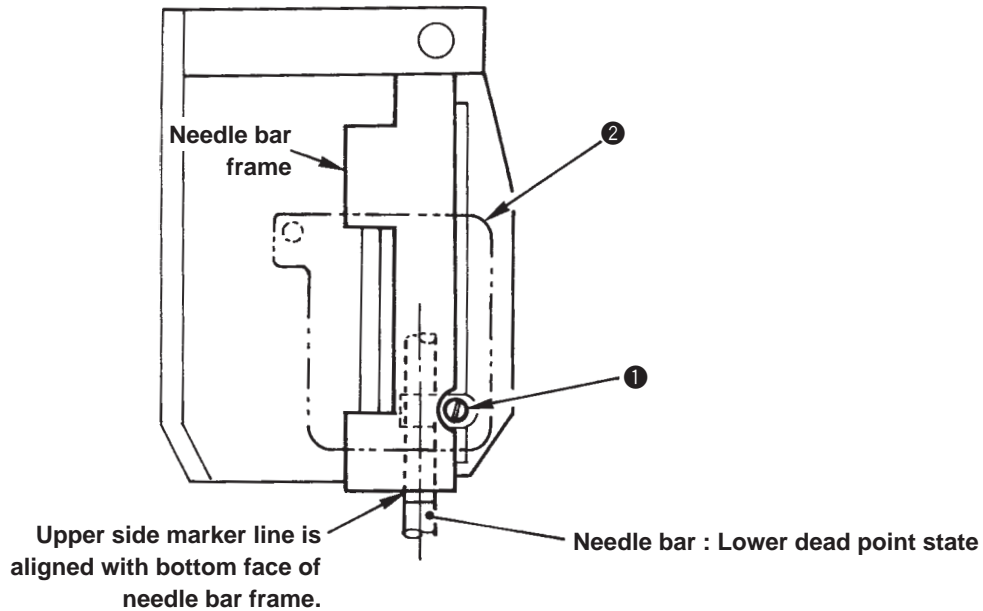

② Adjusting the upper/lower positions of the needle bar frame (APW-298)

The respective clearances of the upper and lower positions of the needle bar frame and the needle bar become the values described in the table below.

Clearance	a	b	c
Needle bar connection			
2 needles	0.2 m/m or more	0	0.2 m/m or more
1 needle	0.2 m/m or more	*	0.2 m/m or more

Portion with * (asterisk) mark : the clearance should be 0.15 m/m or more at the time when pushing up the needle bar locating at its highest position from the bottom.

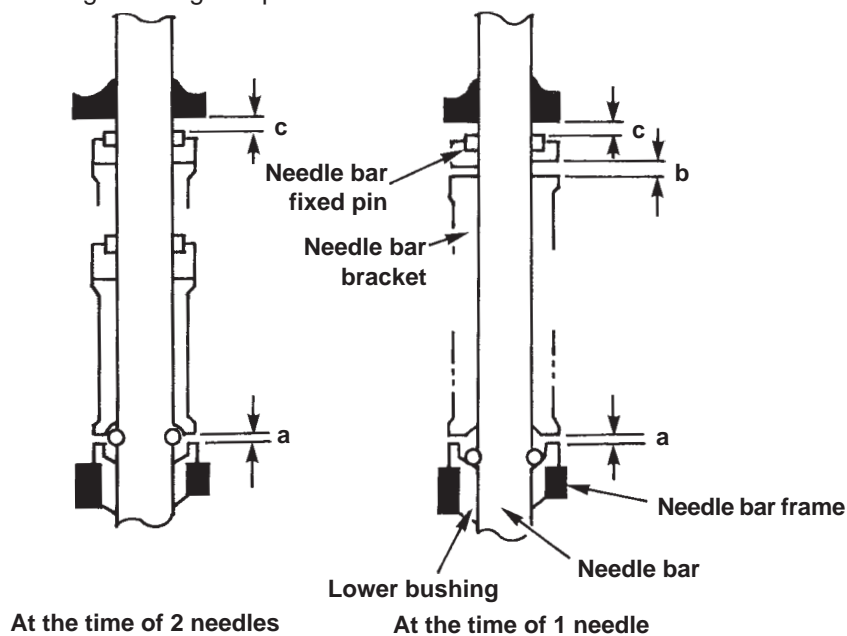

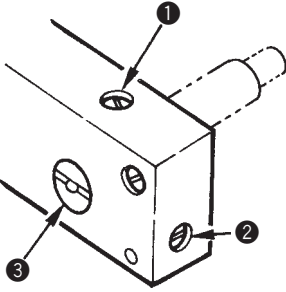
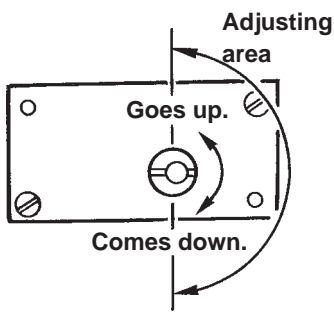
Adjustment Procedures	Results of Improper Adjustment
<p>1) To adjust the height of the needle bar, loosen needle bar bracket screw ❶.</p> <p>2) Turn the hand pulley to bring the needle bar to its lower dead point and remove face plate cover ❷ of the binder base to adjust the height.</p> <ul style="list-style-type: none"> ○ Adjust so that the upper marker line engraved on the needle bar is aligned with the bottom face of the needle bar frame when the needle bar is in the lower dead point state. 	
<div style="display: flex; justify-content: space-around; align-items: center;">   </div> <p>Loosen setscrews ❶ and ❷ in the needle bar frame shaft base and turn needle bar frame shaft ❸ counterclockwise. Then the needle bar frame goes up, and clearance "a" becomes smaller and clearance "c" becomes larger.</p> <p>Turn it clockwise and the respective clearances are reversed.</p> <p>(Adjusting area is up to the position where the slot of needle bar frame shaft ❸ becomes vertical.)</p> <p>After performing the adjustment, tighten setscrews ❶ and ❷ to fix needle bar frame shaft ❸.</p>	<ul style="list-style-type: none"> • When the needle bar frame is excessively high : <ul style="list-style-type: none"> ○ Needle bar locking is hard since clearance "a" is small, and 1-needle stop failure of slant sewing occurs. (Difference on the sewing end side becomes smaller than the given value.) In addition, needle bar locking failure occurs at the sewing end. (One stitch drops at the sewing start of the slant sewing.) • When the needle bar frame is excessively low : <ul style="list-style-type: none"> ○ Needle bar releasing is hard since clearance "c" is small, and 1-needle release failure of slant sewing occurs. (Difference on the sewing start side becomes larger than the given value.)

3) Needle feed components

Standard Adjustment

① Needle feed adjusting (cam section)

It is normal that the needle feed amount is "0" (zero) when needle feed adjusting motor ① stops at the origin.

... When the MACHINE READY key is pressed, needle feed adjusting motor ① performs the origin retrieval and stops at the origin.

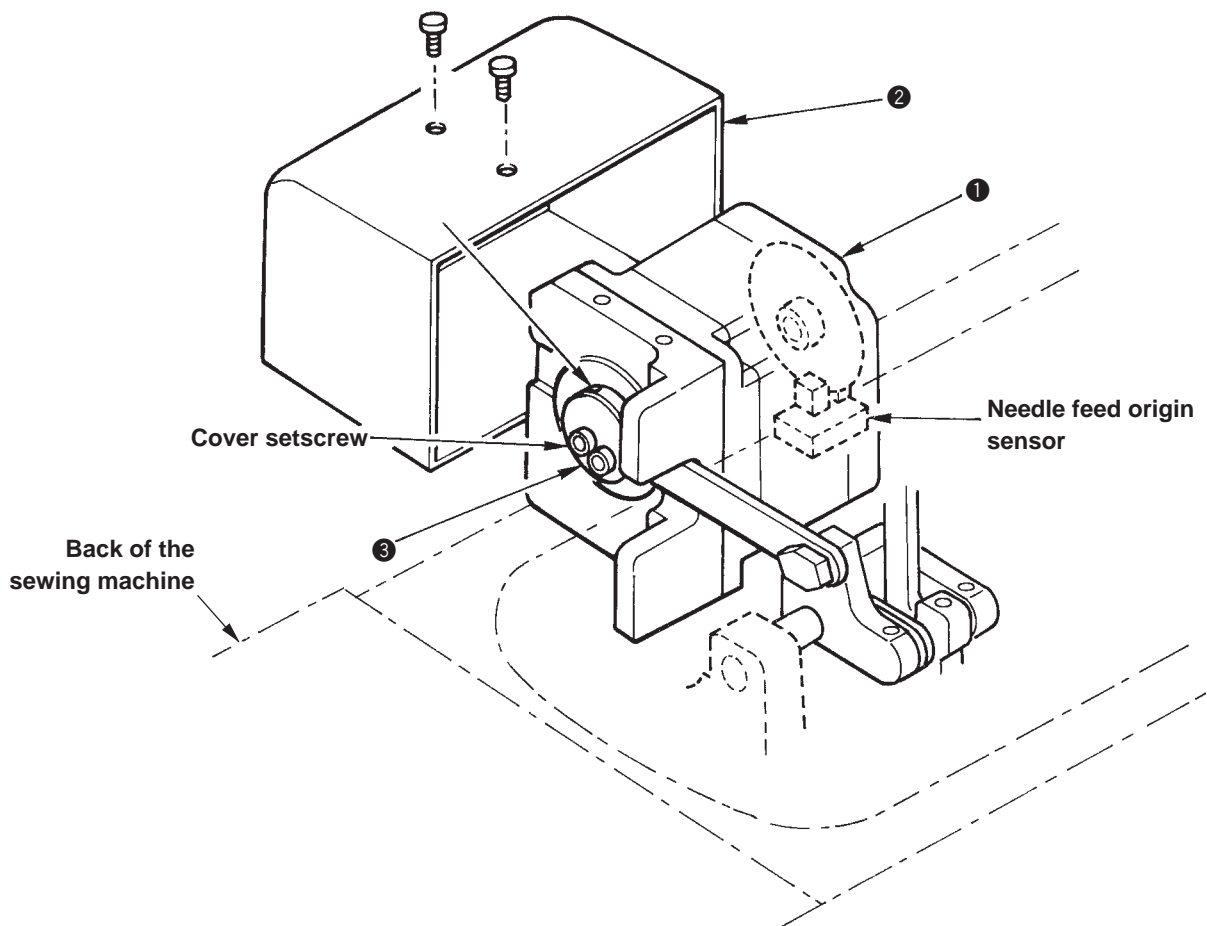

Adjustment Procedures	Results of Improper Adjustment
<p>1) Remove needle feed adjusting motor cover ②.</p> <p>2) Turn ON the power and perform the sewing machine independent operation at 500 rpm under the continuous mode. ... At this time, needle feed adjusting motor ① is excited at the position of the origin.</p> <p>3) Loosen clamp screw ④ in needle feed adjusting cam ③.</p> <p>4) Turn needle feed adjusting cam ③ while checking the longitudinal move of the needle bar and tighten clamp screw ④ in the cam at the position (angle) where the longitudinal move stops to fix the cam. ... The point of the position (angle) where the longitudinal move stops is the position where the two cover setscrews come just below.</p> <p>(Caution) In addition to the normal installing angle, there is another angle where the longitudinal move stops. For reference, the longitudinal move becomes "0" (zero) at the angle where the two cover setscrews come just above. However, the needle feed direction is reverse to the normal one at this fixing angle when the actual sewing is operated. So, do not adjust to this state.</p>	<p>○ In the case where the needle feed amount does not become "0" (zero) when the needle feed adjusting motor stops at the origin, the needle feed amount in accordance with panel input value (percentage as against the sewing pitch) cannot be obtained. Accordingly, the needle feed cannot be stopped (setting the panel input value to 0%).</p> <p>In addition, the needle entry position in terms of stitches slips from the given entry position.</p>

Standard Adjustment

② Adjusting the installing position of the needle bar frame

Adjust the installing position of the needle bar frame so that the needle is in the center of the needle hole (slot) when the needle feed amount is "0" (zero).

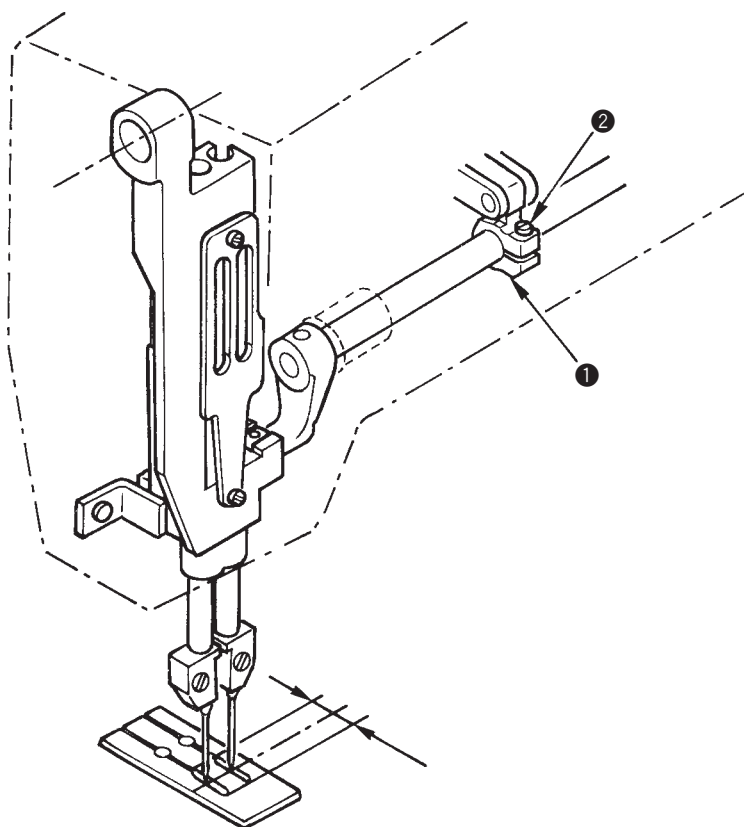

Adjustment Procedures	Results of Improper Adjustment
<p>* Perform this adjustment after the adjustment of the needle feed adjusting cam described in the previous clause.</p> <ol style="list-style-type: none"> 1) Turn OFF the power after the needle feed adjusting motor origin retrieval operation (turn ON the MACHINE READY key). 2) Turn the hand pulley to lower the needle to the needle hole. 3) Remove the top cover (lid located on the top surface of the sewing machine). 4) Loosen clamp screw ② in needle feed rocking rear arm ①. 5) Move the needle bar frame to and fro, position so that the needle is in the center of the needle hole, and tighten clamp screw ② in needle feed rocking rear arm ①. 	<ul style="list-style-type: none"> ○ When the position of the needle bar frame is not adjusted as described on the left side : Stitches slip from the given needle entry position and when the adjustment is particularly improper, interference of the respective parts occurs. <ul style="list-style-type: none"> • Interference of upper knife with needle thread trimmer knife • Interference of needle bar frame • Interference of needle with needle hole

Standard Adjustment

③ Adjusting the timing of the needle feed operation

Adjust the timing of the needle feed operation so that the timing of the hook catching thread is not slipped even when the needle feed amount is changed.

... It is normal that the needle bar does not move to and fro even when turning needle feed adjusting motor ① at the timing of alignment of needle and hook (longitudinal move is within 0.5 mm).

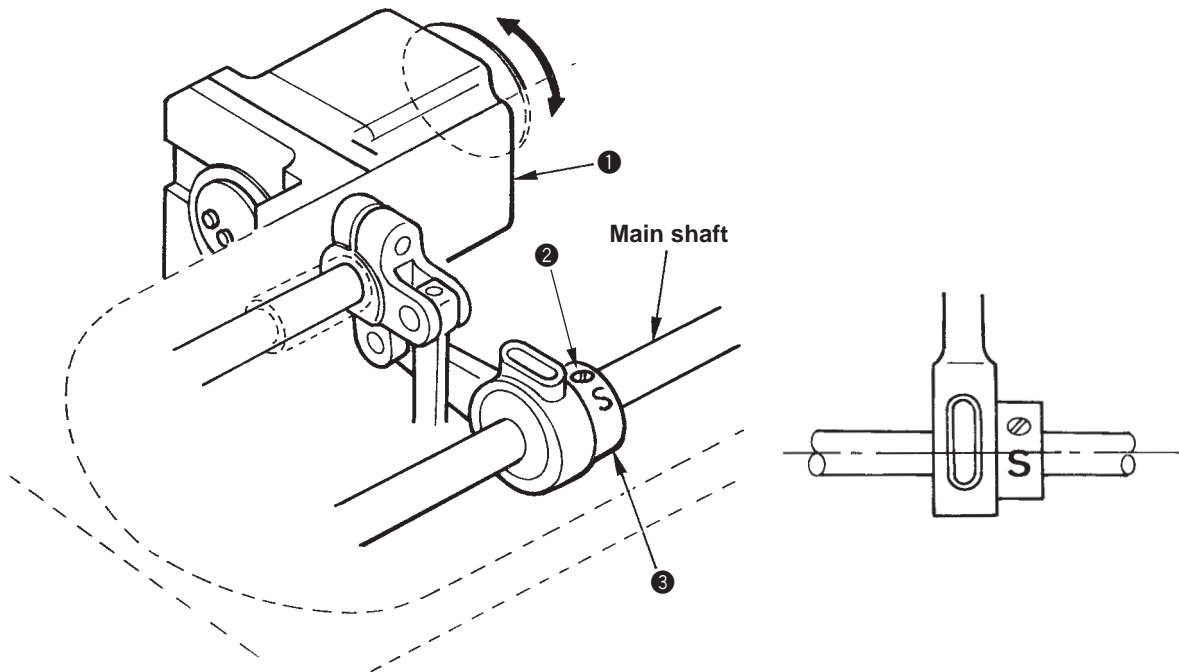

Locus of needle feed and needle bar

The locus of normal needle feed is as shown in the figures below.

The ellipse is increased or reduced in the state that the point of the timing of the hook catching thread does not slip longitudinally.

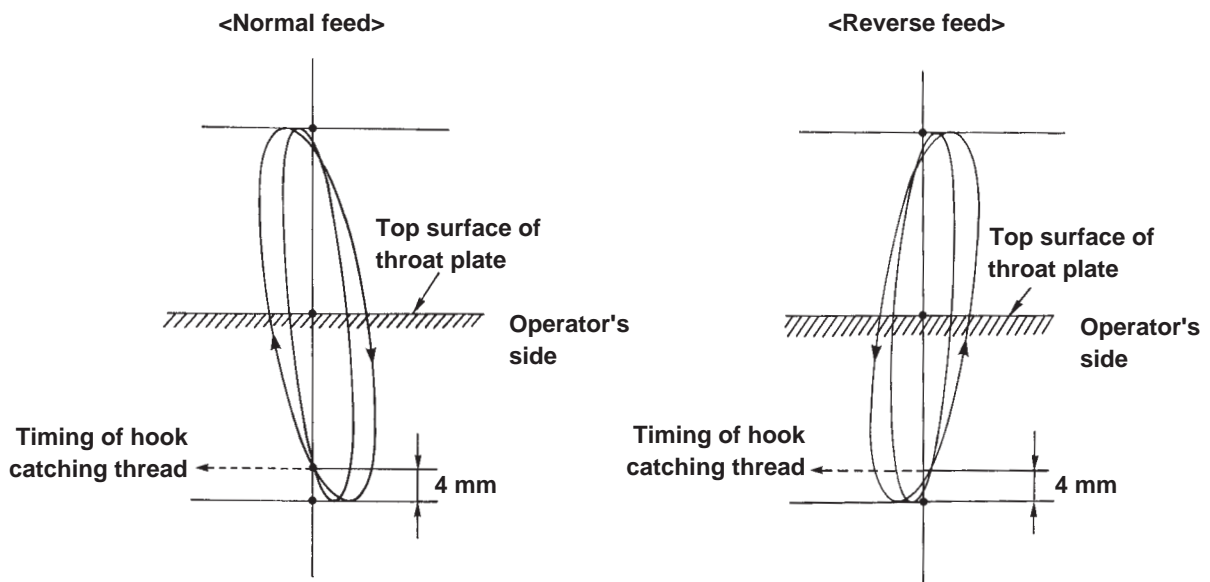

Adjustment Procedures	Results of Improper Adjustment
<p>* Perform this adjustment after the adjustments of the needle feed adjusting cam and the installing position of the needle bar frame described in the previous clauses.</p> <ol style="list-style-type: none"> 1) Turn OFF the power to the machine. 2) Turn the hand pulley to align the needle with the hook. 3) Remove the top cover. 4) Loosen setscrew ② in the upper knife driving cam. 5) Gradually move the angle of upper knife driving cam ③ and temporarily tighten the cam. Then turn the needle feed adjusting motor to check the longitudinal move of needle bar. 6) Tighten the setscrew ② in the upper knife driving cam at the angle where the longitudinal move of needle bar stops to fix the cam. <p>(Point : The longitudinal move of needle bar stops at the position where letter "S" of the cam faces upward as shown in the figure on the left.)</p> <p>.... It is a difficult job and takes time to adjust the cam to the angle where the longitudinal move of needle bar completely stops.</p> <p>It is no problem functionally if the longitudinal move is within 0.5 mm.</p>	<ul style="list-style-type: none"> ○ When the adjustment of timing of the needle feed is improper, a given locus of needle feed cannot be obtained. As a result, needle feed effect as against the sewing material is lost. ○ Hook adjusting timing, when needle feed amount is changed (when the sewing pitch is changed or the like), is slipped and sewing conditions will be deteriorated.

4) Needle thread trimmer components

Standard Adjustment

① Adjusting the forward end position of the needle thread trimmer unit

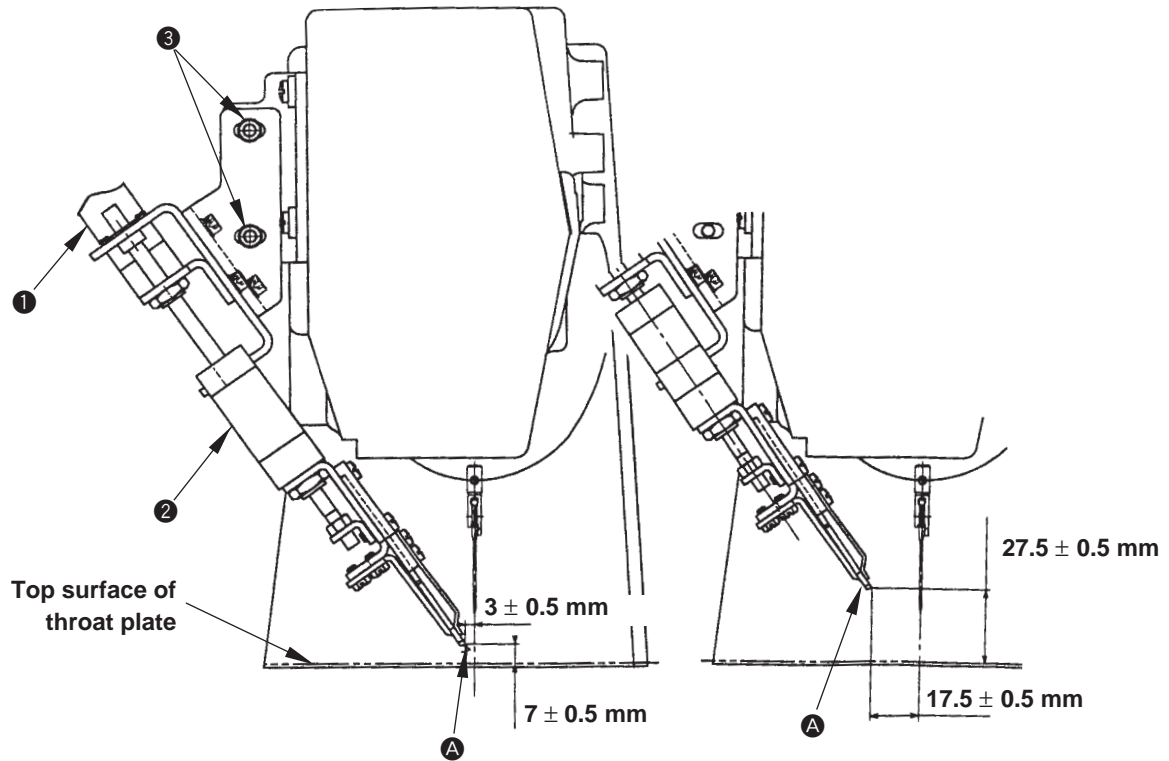

② Adjusting the lateral position of the needle thread trimmer unit

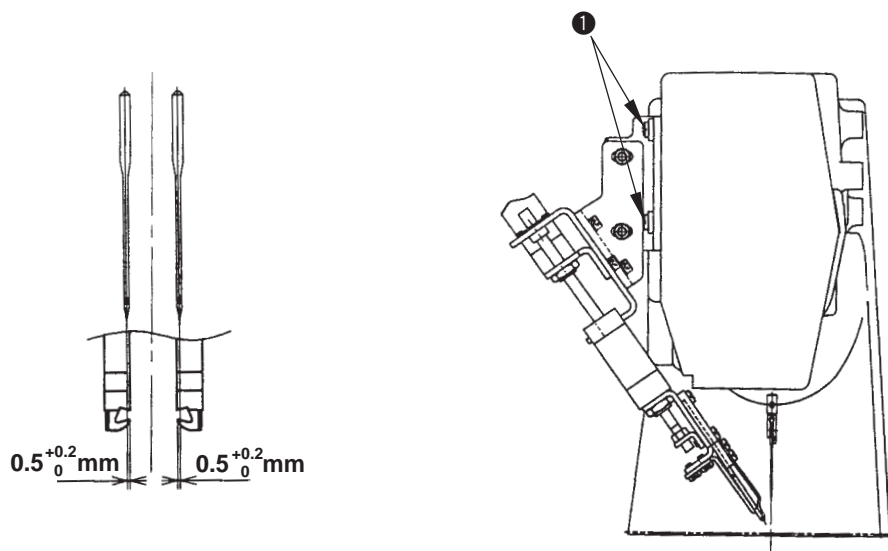

Adjustment Procedures	Results of Improper Adjustment
<p>1) The forward end position of the needle thread trimmer unit is where top end A of the moving knife is 3 ± 0.5 mm away from the needle and 7 ± 0.5 mm away from the top surface of the throat plate when knife unit moving cylinder 1 and knife driving cylinder 2 are in full stroke.</p> <p>2) Top end A of the moving knife is 17.5 ± 0.5 mm away from the needle and 27.5 ± 0.5 mm away from the top surface of the throat plate when knife unit moving cylinder 1 is returned</p> <ul style="list-style-type: none"> ○ Loosen two setscrews 3 and perform positioning of the top end of the moving knife for adjustment. 	<ul style="list-style-type: none"> ○ Thread trimming failure occurs. ○ Length of thread remaining from the fabric is lengthened or shortened. ○ Interference with other components occurs.
<p>1) For the lateral position of the needle thread trimmer unit, adjust the center of the needles to the center of the right and left moving knives.</p> <p>At this time, the lapping amount of the respective needle centers and the top end of the moving knife is $0.5 \begin{smallmatrix} +0.2 \\ 0 \end{smallmatrix}$ mm. (Both right and left centers)</p> <ul style="list-style-type: none"> ○ Loosen two setscrews 1 and adjust the position. 	<ul style="list-style-type: none"> ○ Thread trimming failure occurs.

Standard Adjustment

③ Adjusting the width of the moving knife of the knife unit

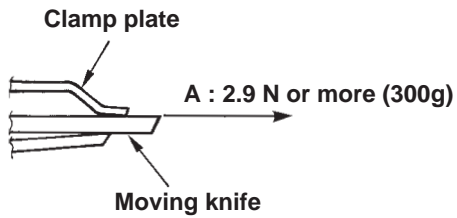
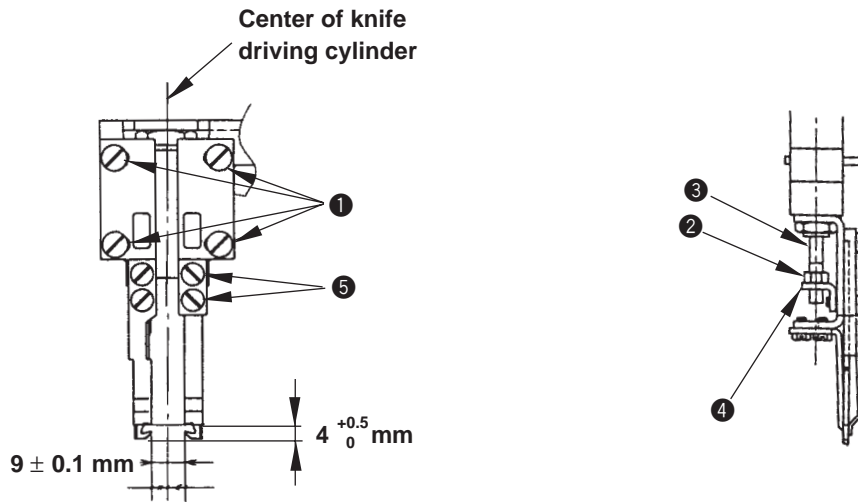

Needle gauge	Dimension	
10 mm	9±0.1mm	Standard
12 mm	11±0.1mm	
14 mm	13±0.1mm	

④ Adjusting the fixed knife

- The fixed knife has to be selected according to the needle gauge. Replace the fixed knife when changing the needle gauge after delivery.

Needle gauge	Selection of type	Part No.	
10 mm	Fixed knife (common to right/left)	25442302	Standard
12 mm	Fixed knife, left	25443102	
	Fixed knife, right	25443201	
14 mm	Fixed knife, left	25443300	
	Fixed knife, right	25443409	

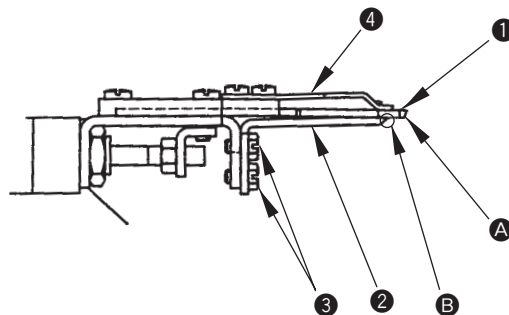

Adjustment Procedures	Results of Improper Adjustment
<p>1) Lateral dimension of the top end of the moving knife is 9 ± 0.1 mm. However, this dimension changes according to the needle gauge. Adjust the dimension to the needle gauge. Adjust the distance of the top end of the moving knife using four setscrews ❶ in the moving knife guide.</p> <p>(Caution) When performing this adjustment, adjust so that the right and left moving knives in terms of the center of knife driving cylinder are set to the same dimension.</p> <p>2) Projecting amount of the top end of the right/left moving knives is $4^{+0.5}_0$ mm away from the top end of the clamp when the moving knife cylinder has been fully pressed (full stroke).</p> <ul style="list-style-type: none"> ○ Loosen nut ❷ in the moving knife driving cylinder, turn moving knife driving cylinder rod ❸, and move moving knife driving plate ❹ in the direction of the arrow to adjust. <p>3) Needle thread retaining force should retain spun #60 with 2.9N or more in the direction A.</p> <ul style="list-style-type: none"> ○ Adjust with two screws ❺ so that the position of the clamp plate is $4^{+0.5}_0$ mm from the top end of the moving knife. ○ Attach the clamp plate so that it is parallel to the moving knife. 	<ul style="list-style-type: none"> ○ Thread trimming failure occurs. ○ Thread trimming failure or clamp failure occurs. ○ When the retaining force is insufficient, slip-off of thread at the sewing start occur
<p>1) Fixed knife ❷ makes plane A (blade face) of moving knife ❶ come in close contact with top end section B of fixed knife ❷.</p> <ul style="list-style-type: none"> ○ Loosen two setscrews ❸ in the fixed knife, make plane A of the moving knife come in close contact with the top end of the fixed knife, then fix the fixed knife. <p>(Caution) When adjusting the fixed knife, perform the adjustment with clamp ❹ installed.</p>	<ul style="list-style-type: none"> ○ Thread trimming failure or single thread breakage occurs.

5) Bobbin thread trimmer components

Standard Adjustment

① Adjusting the bobbin thread knife

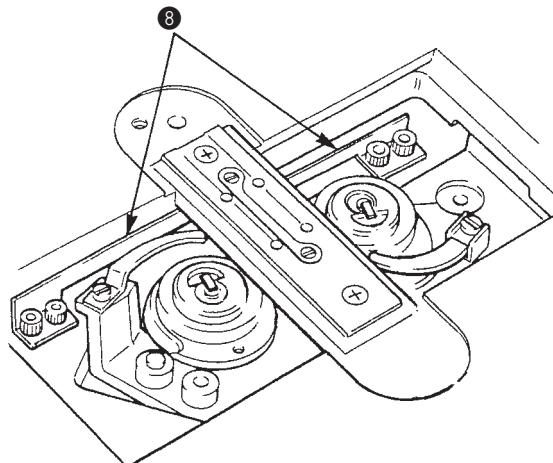
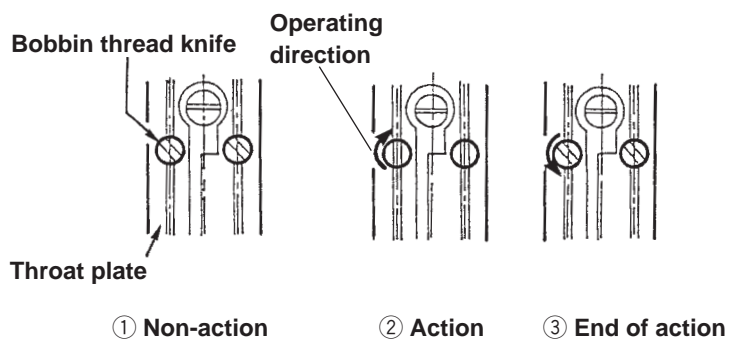
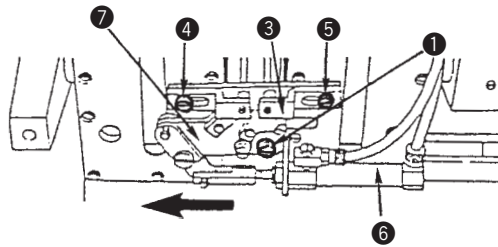
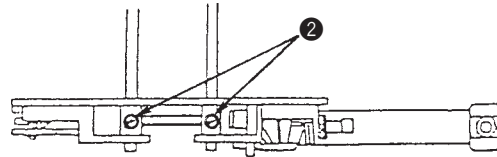

Adjustment Procedures	Results of Improper Adjustment
<p>1) Position of the bobbin thread knife to the throat plate In order to prevent the bobbin thread knife from being pinched in the throat plate while cutting the thread, it is important to set the knife perpendicular to the throat plate.</p> <ol style="list-style-type: none"> 1. Loosen screw ❶ and operate bobbin thread knife driving cylinder ❸. 2. Set bobbin thread knife bracket ❹ so that the knife is not pinched in the throat plate and firmly tighten screw ❶. <p>2) Position and height of the bobbin thread knife The top ends of both left and right knives must be even with the throat plate surface, and the grooves in the knives must be parallel to the grooves in the throat plate when the knives actuate.</p> <ol style="list-style-type: none"> 1. Loosen screws ❷ and adjust so that the top ends of the knives are even with the throat plate surface. 2. Press bobbin thread knife driving cylinder ❸ toward A and adjust so that the grooves in the knives are parallel to the grooves in the throat plate. 3. Securely tighten screws ❷. <p>3) How to adjust the position of the bobbin thread knife in replacing gauges Loosen setscrews ❹ and ❺ of bobbin thread knife presser plate ❸, and the bobbin thread knife moves to the right or left together with the bobbin thread knife presser plate.</p> <p>4) How to replace the bobbin thread knife Loosen setscrews ❷, and you can pull out the knife downward.</p> <p>5) Adjusting the sharpness of the bobbin thread knife Adjust the sharpness of the bobbin thread knife, while properly pressing thread grasping presser springs ❽ (figure on the left) against the bobbin thread knife. The force with which the springs are pressed against the knife should be minimized as far as the knife cuts the thread without fail. This helps lengthen the life of the knife.</p>	<ul style="list-style-type: none"> ○ When the bobbin thread knife is lower than the top surface of the throat plate, bobbin thread trimming failure occurs.

6) Center knife components

Standard Adjustment

Adjust the relevant distances of the center knife as shown in the figure below.

- Highest dead point of the center knife 5 mm above the surface side of the throat plate
- Lowest dead point of the center knife 0.5 mm above the surface side of the throat plate

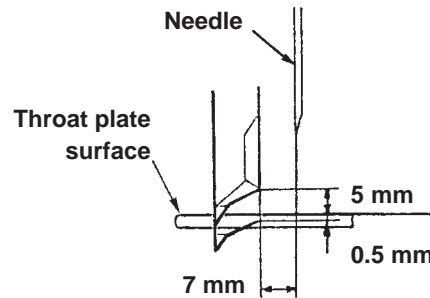

① How to adjust the height of the center knife

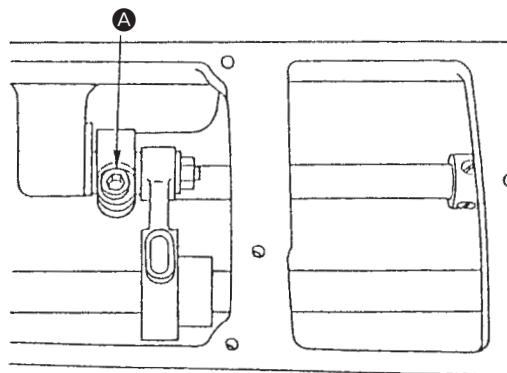

Surface side of the arm

② How to adjust the distance from the needle to the center knife

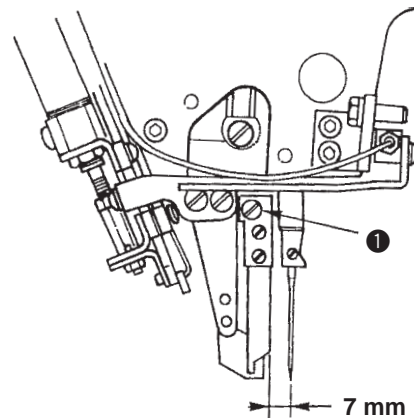

③ Adjusting the sharpness of the center knife

④ Attaching the center knife

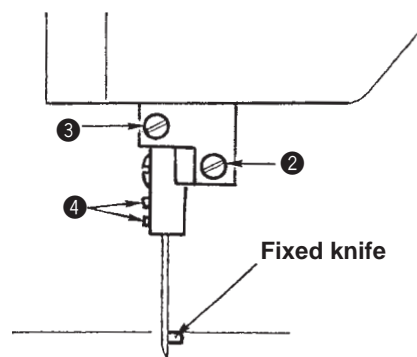

Adjustment Procedures	Results of Improper Adjustment
<p>① How to adjust the height of the center knife Loosen screw ① and adjust so that a 5 mm clearance is obtained when the center knife comes to its highest dead point by raising or lowering the center knife. When tightening the screw, be careful not to provide it with a lateral play.</p> <p>② How to adjust the distance from the needle to the center knife Loosen screw ① and correctly adjust the position of the center knife by moving it forward or backward.</p> <p>③ Adjusting the sharpness of the center knife The sharpness of the center knife is adjusted by pressing the side face of the center knife to the blade section of the fixed knife of the throat plate. Move the center knife laterally by screw ② or rotate it by screw ③ to obtain the suitable pressing force. Be sure to adjust the pressing force as light as possible so that the center knife completely cuts the two plies of the fabric used.</p> <p>④ Attaching and removing the center knife ○ Removing the center knife Loosen screws ④, and remove the center knife. Tighten screws ④, and attach the center knife. At this time, push the center knife to the base until it will go no further and fix at that position.</p>	

7) Hook components

Standard Adjustment

① Adjusting the timing of the hook to the needle

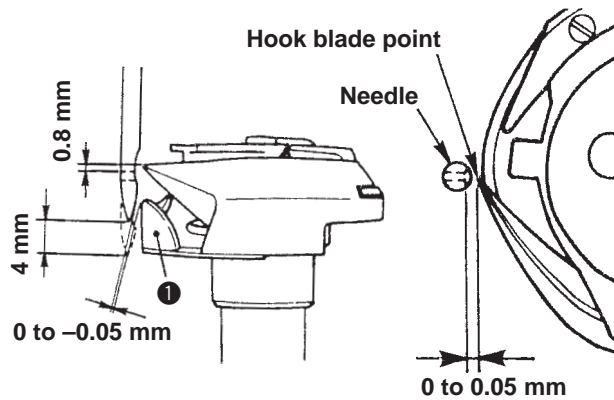

② Adjusting the timing of the hook

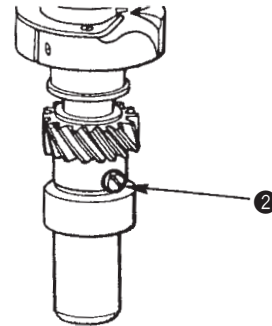

③ Adjusting the clearance between the needle and the hook blade point

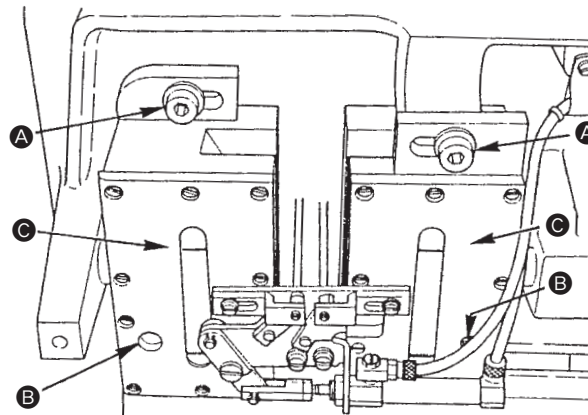

④ Removing and attaching the hooks

- Removing the hooks
 - ① Remove the throat plate.
 - ② Remove the bobbin case opening lever.
 - ③ Loosen three setscrews ② in the small gear of the hook shaft.
 - ④ Turn the handwheel until the needle bar is raised to its highest position and take out the hooks.
- Attaching the hooks
 - ① Reverse the above procedures.
 - ② Turn by hand the bobbin case holder until its projection rests in the groove on the throat plate and fix the throat plate.

⑤ Adjusting the bobbin case opening lever

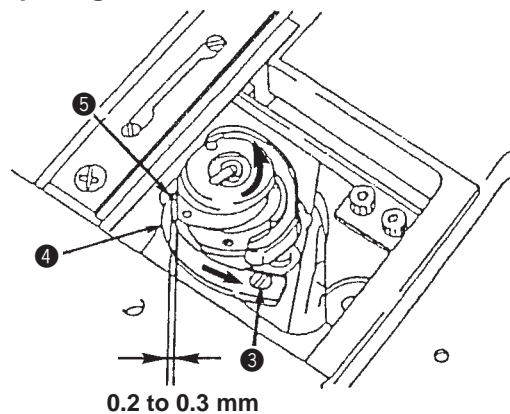

Adjustment Procedures	Results of Improper Adjustment
<p>① Adjusting the timing of the hook to the needle</p> <ul style="list-style-type: none"> ○ Remove the throat plate. ○ When the needle has gone up 4 mm from its lowest point. adjust the position of the hook so that the blade points of left/right hooks align with the center of the needle. At this time, adjust so that the clearance between the side face of the needle and needle guard ① of the hook is 0 to -0.05 mm, that the clearance between the side face of the needle and the blade point is 0 to 0.05 mm and that the distance between the top end of the needle hole and the hook blade point is 0.8 mm. <p>② Adjusting the timing of the hook</p> <ul style="list-style-type: none"> ○ Loosen three setscrews ② in the small gear of the hook shaft. Manually turn the hook to make the hook blade point align with the center of the needle. Then tighten setscrews ② while pressing the hook downwards and the gear upwards in order to eliminate a vertical play of the hook shaft. <p>③ Adjusting the clearance between the needle and the hook blade point</p> <ul style="list-style-type: none"> ○ Remove the throat plate and tilt the machine backwards. ○ Loosen screws ① and ② in the hook driving shaft saddle located on the machine side to be adjusted. ○ Lightly tap hook driving shaft saddle ③, and move it to the left or right until the clearance between the needle and the blade point of the hook is adjusted to 0 to -0.05 mm. Then firmly tighten screws ①. In addition, moderately tighten screws ②. <p>(Caution) Screw ② is fixed holding the hook driving shaft bushing. If it is tightened excessively, the turning torque of the hook driving shaft will be increased. So, be careful not to tighten it excessively.</p> <p>⑤ Adjusting the bobbin case opening lever</p> <ul style="list-style-type: none"> ○ Turn the handwheel by hand in the regular direction to let bobbin case opening lever ④ withdraw to the end of its stroke in the direction of arrow and make sure that there is a clearance of 0.2 to 0.3 mm between the bobbin case opening lever and projection ⑤ of the bobbin case (turn the bobbin case in the direction of arrow and hold it in place by hand). This can be adjusted by loosening screw ③ in the bobbin case opening lever. 	

8) Wiper components

Standard Adjustment

① Adjusting the wiper

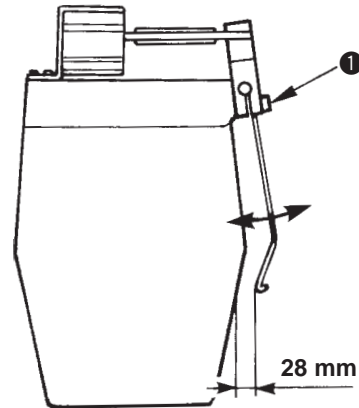

9) Lubrication components

Standard Adjustment

① Adjusting the injector for the reflux of the face plate components

- Reflux of the face plate components is performed with injector ① installed on the bottom side of the machine bed.
- The standard value of the reflux amount is obtained at the position where the injector adjustment screw ② is turned back four times from its fully screwed state.

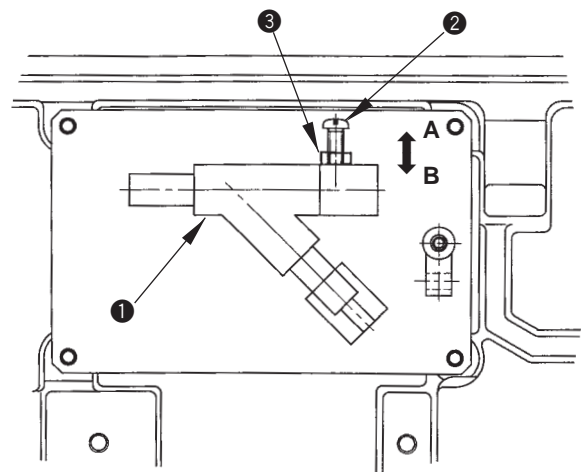

- Adjusting the amount of oil in the hook

- Appropriate amount of oil in the hook is obtained when a sheet of paper is placed approximately 1 cm away from the hook, operate the sewing machine for 10 seconds, and oil splashes stick to the paper at the height of the hook blade point as shown in the figure.

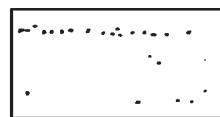
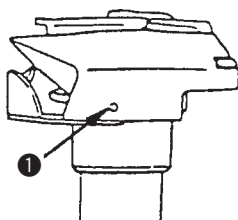

Min.

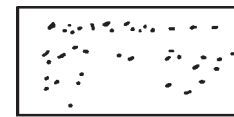

Max.

Adjustment Procedures	Results of Improper Adjustment
<p>Adjust the wiper with clamp screw ❶ so that the dimension of clearance between the bottom end of the wiper and the face plate of the machine head is 28 mm when the cylinder is actuated.</p>	<p>If the wiper operating amount is small, slip-off of thread at the sewing start occurs.</p> <p>If the wiper operating amount is large, defective stitch tightness at the sewing start occurs.</p>

Adjustment Procedures	Results of Improper Adjustment
<p>1) Tilt the machine head.</p> <p>2) Loosen nut ❸ and move screw ❷ in the direction of the arrow to adjust the injector.</p> <ul style="list-style-type: none"> ○ Moving the screw in the direction A strengthens the injector and the reflux amount is increased. ○ Moving the screw in the direction B weakens the injector and the reflux amount is decreased. 	<ul style="list-style-type: none"> ○ Oil may drop from the bottom of the face plate.
<p>1) Perform the adjustment of the amount of oil with screw ❶ in the outer hook.</p> <p>Turning clockwise decreases the amount of oil and turning it counterclockwise increases the amount of oil.</p>	

10) Thread tension components

Standard Adjustment

① Adjusting the thread take-up spring

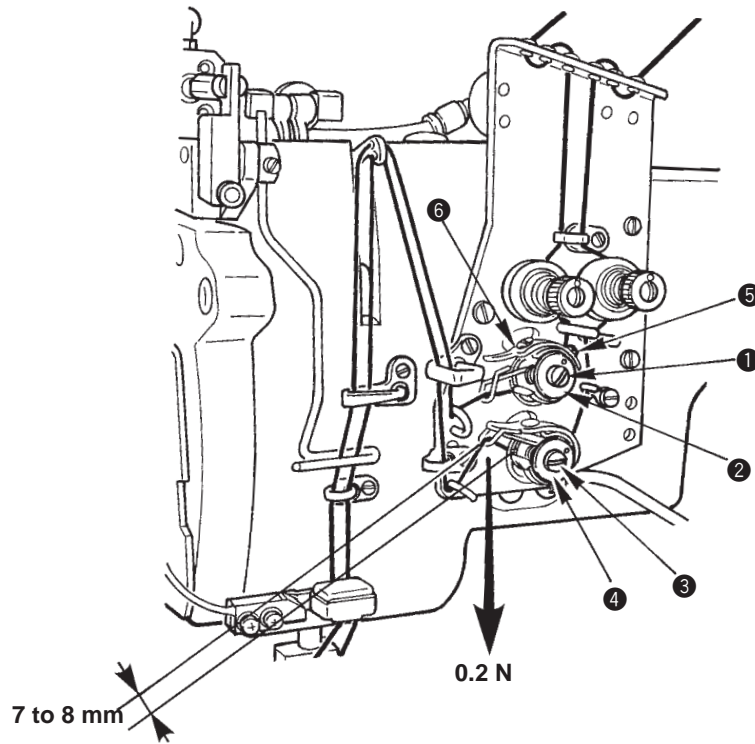

② Adjusting the timing of the thread tension disc to start "floating"

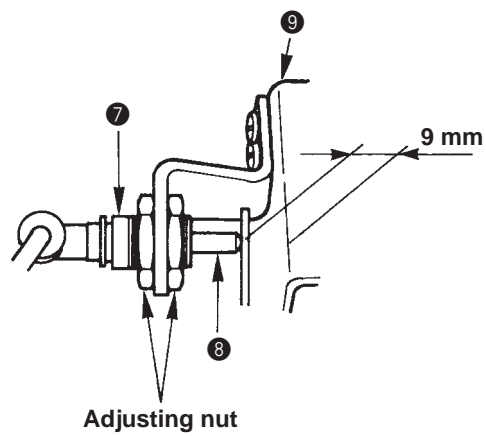

(2) Device components

1) Binder components

Standard Adjustment

① Front binder

a) Adjustment of torsion

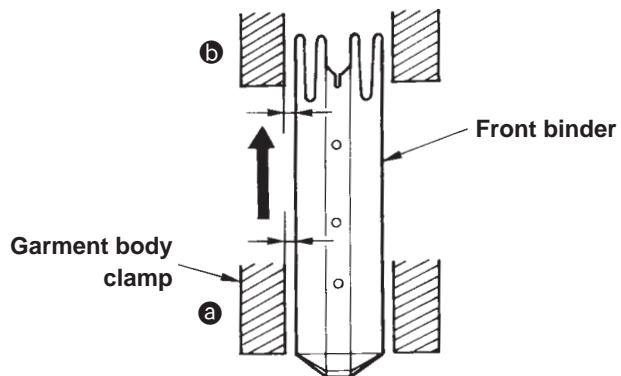

b) Lateral adjustment

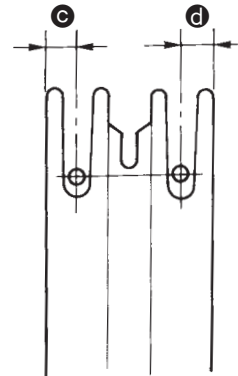

c) Adjustment of inclination

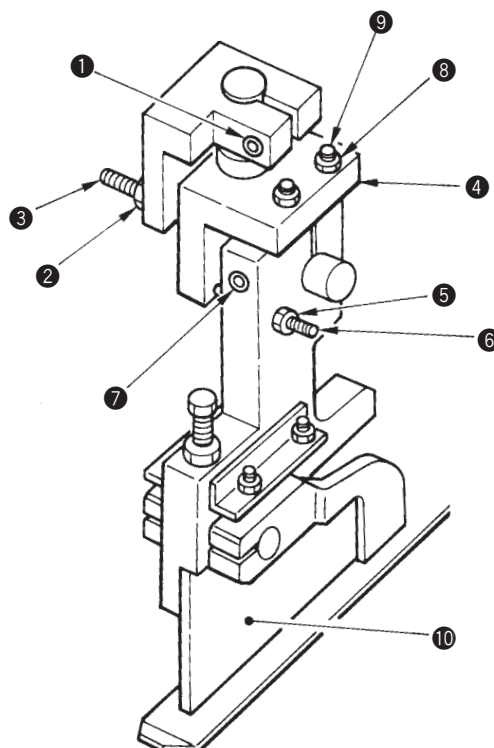

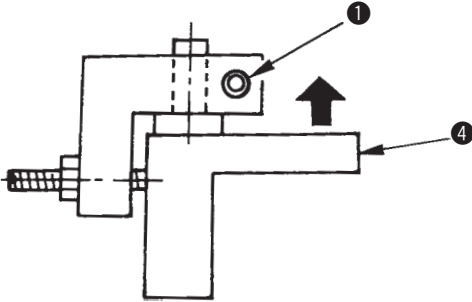
Adjustment Procedures	Results of Improper Adjustment
<p>Ⓐ Adjustment of torsion</p> <p>1) The difference (parallelism) of the clearance between the garment body clamp and the front binder (welt patch ruler) should be within 0.2 mm when the top end of the garment body clamp has moved from position a to that of b.</p> <ul style="list-style-type: none"> ○ When the aforementioned dimension is not obtained, loosen setscrew ①, loosen two nuts ②, and adjust the torsion of the front binder while pressing two setscrews ③ on base ④. <p>(Caution) When setscrew ① is loosened, the front binder falls down. Push upward (in the direction of the arrow) base ④ when tightening setscrew ①.</p>  <p>Ⓑ Lateral adjustment</p> <p>1) Check the needle entry position (dimensions c and d in the figure should be laterally equal.).</p> <ul style="list-style-type: none"> ○ When the dimensions c and d are different from each other, loosen screw ⑦ and nut ⑤, and move binder ⑩ to the right or left. ○ The stopper in the lateral direction of the binder is adjusted with screw ⑥. ○ Slightly loosen nut ⑧ and screw ⑨ when the binder cannot be laterally adjusted. <p>(Caution) The inclination of the front binder changes when ⑧ and ⑨ are loosened. Adjust the inclination referring to Ⓒ Adjustment of inclination.</p> <p>Ⓒ Adjustment of inclination</p> <p>1) In the state that the front binder rides on the welt patch ruller with the power OFF, loosen screws ⑦ and ⑨, and nut ⑧, and perform adjustment of the parallelism of the front binder.</p>	<ul style="list-style-type: none"> ○ If the parallel move is not obtained, the front and rear welt patch widths become uneven. ○ If c and d are not equal, the difference of right and left welt patch widths is caused.

Standard Adjustment

① Front binder

④ Adjustment of longitudinal position

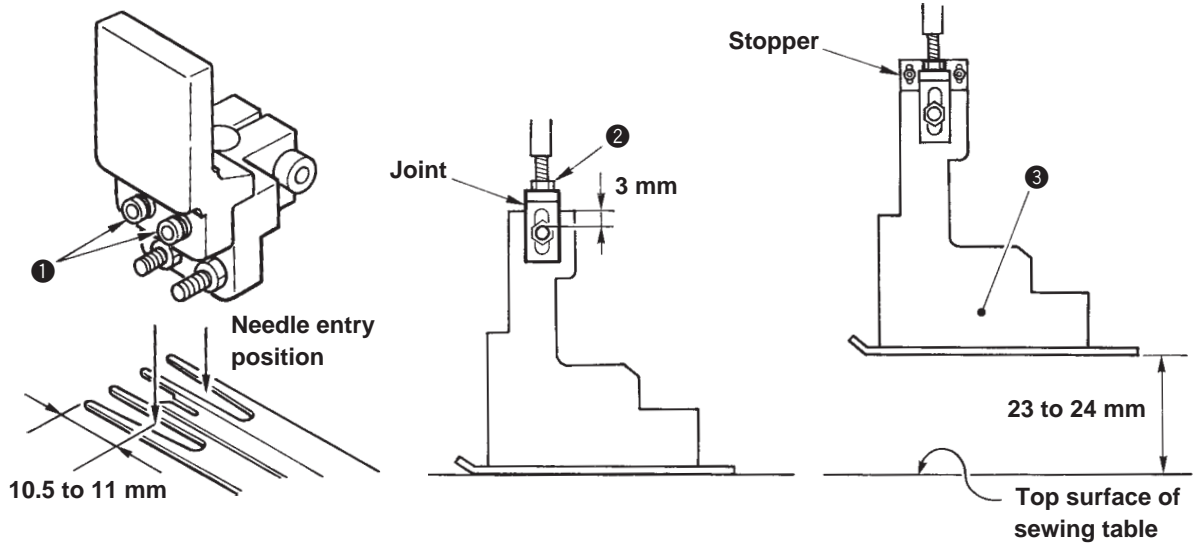

⑤ Adjustment of height

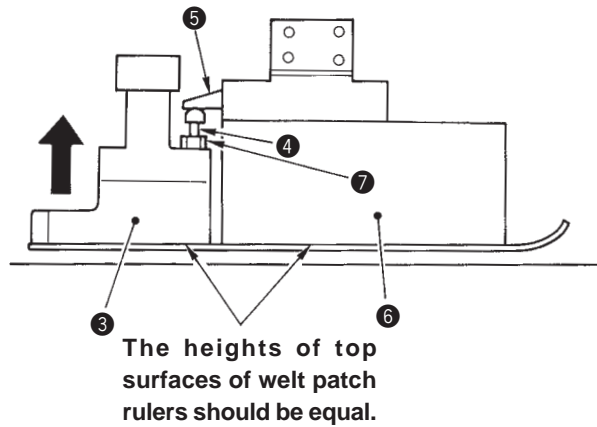

⑥ Adjustment of material guide

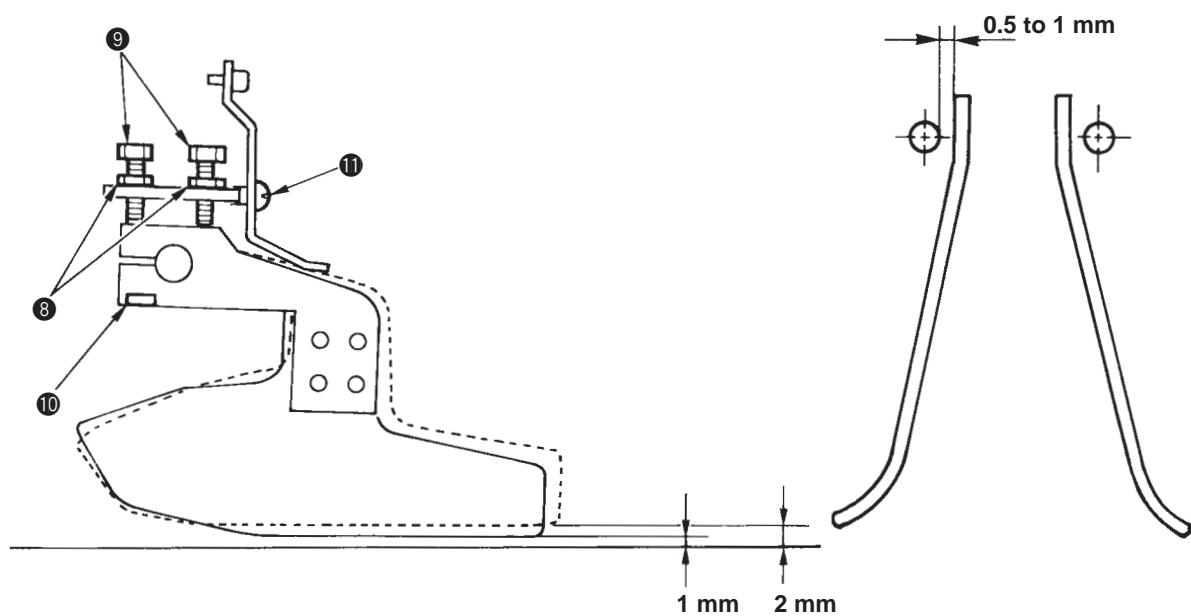

Adjustment Procedures	Results of Improper Adjustment
<p>d) Adjustment of longitudinal position</p> <p>1) Loosen screws ❶ and adjust so that the distance from the needle entry position to the top end of the welt patch ruler is 10.5 to 11 mm.</p> <p>(Caution) Check that the knife cover section of binder base does not interfere with the center knife.</p> <p>e) Adjustment of height</p> <p>1) Turn ON the power, loosen the setscrew of the stopper, and adjust the height so that the distance from the top surface of the sewing table to the bottom face of the welt patch ruler is 23 to 24 mm when the binder goes up.</p> <p>2) Loosen nut ❷ at the top end of the cylinder, and adjust so that a clearance of 3 mm is provided between the cylinder joint and the pin when the binder comes down (with the power OFF).</p> <p>3) Lift front binder ❸, loosen nut ❺, turn stopper bolt ❻ and adjust so that the heights of the rulers should be equal when the heights of the top surfaces of the welt patch rulers of front binder ❸ and rear binder ❹ are not equal at the position where stopper bolt ❻ comes in contact with binder stopper ❼.</p> <p>f) Adjustment of material guide</p> <p>1) Clearance between the top surface of welt patch ruler when it is pressed and lowered by the material guide spring and the bottom face of the material guide is 1 mm.</p> <p>2) Clearance between the material guide and the welt patch ruler is 2 mm when the material guide goes up.</p> <p>3) Loosen nuts ❽ and adjust the clearance with bolts ❾ when the material guide comes down.</p> <p>4) Clearance between the material guide and the needle in the lateral direction is 0.2 to 0.5 mm at the part of the shank (thick part of the needle).</p> <p>5) Loosen screw ❿ to adjust the clearance.</p> <p>6) Adjust the pressing pressure of the material guide with screw ⓫.</p>	<p>○ If the heights of the front and the rear rulers are not equal, welt patch or interlining may be in danger of being caught in the joint of the ruler at the time of jump feed after start.</p> <p>In addition, garment material may be in danger of being caught in the joint of the ruler.</p>

Standard Adjustment

② Rear binder

a) Adjustment of inclination and longitudinal adjustment

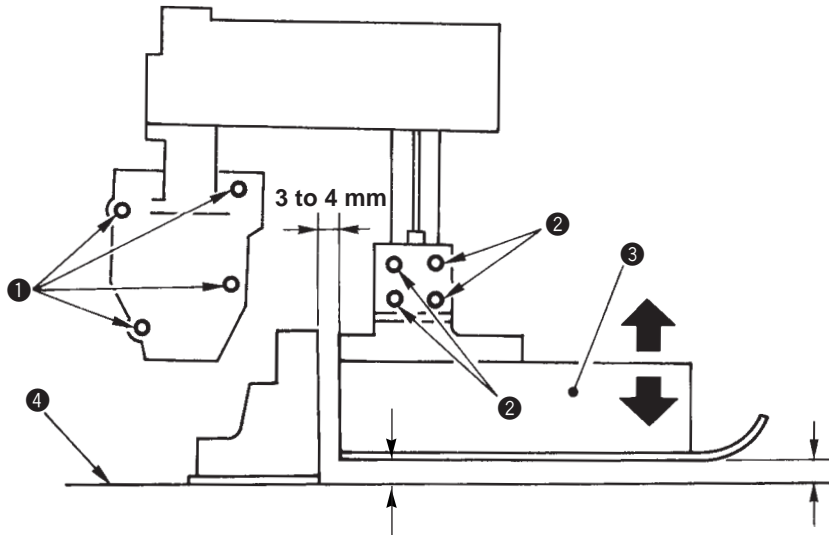

b) Adjustment of torsion

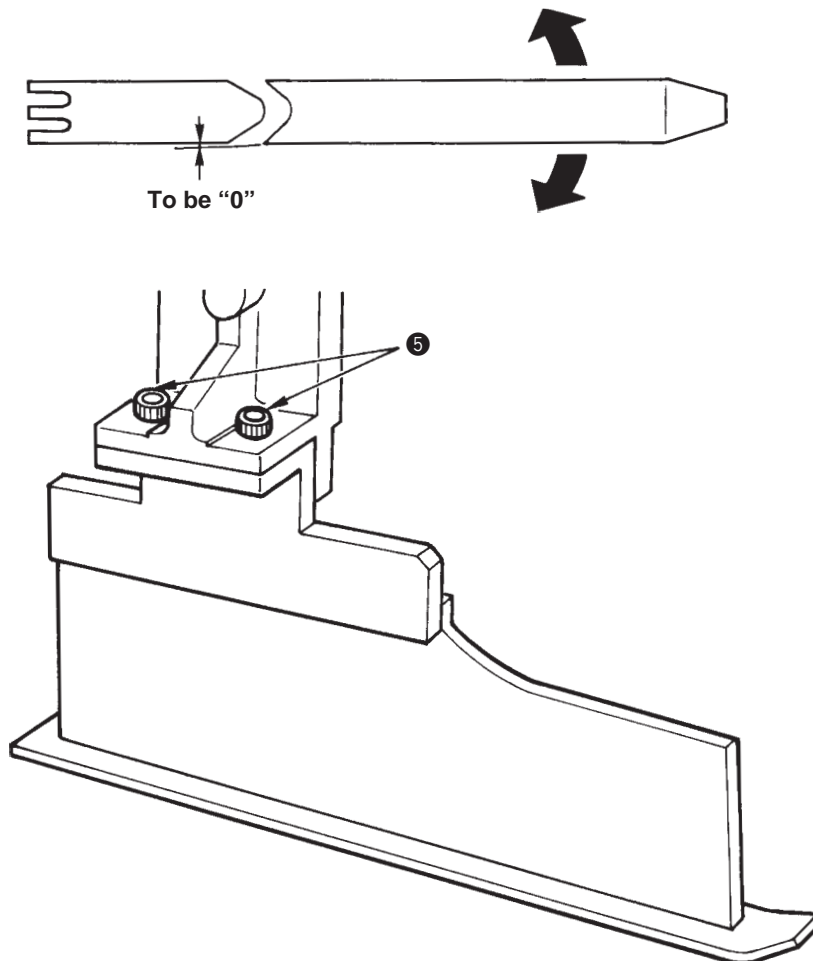

Adjustment Procedures	Results of Improper Adjustment
<p>Ⓐ Adjustment of inclination and longitudinal adjustment</p> <p>1) Loosen four setscrews ② and perform the adjustment of inclination of rear binder ③. Tighten setscrews ② so that the bottom face of the welt patch ruler and the top surface of sewing table ④ should be parallel when the power is turned OFF. At the same time, tighten setscrews ② so that the clearance between rear binder ③ and the front binder is 3 to 4 mm.</p> <p>(Caution)</p> <p>When four setscrews ① in the binder bracket are loosened, not only the inclination of rear binder but also that of all devices mounted on the binder such as front binder, flap feeding unit, etc. will change.</p> <p>Do not loosen the setscrews unless the adjustment of inclination of the whole devices is performed.</p> <p>Ⓑ Adjustment of torsion</p> <p>1) The rear binder is required to be set straight as against the front binder.</p> <p>2) Loosen screws ⑤ to adjust the direction of torsion of the rear binder as against the front binder which has completed the parallel adjustment in terms of the moving direction of the clamp foot.</p>	<p>○ Torsion of the rear binder causes the unevenness of left/right and front/rear of the welt patch.</p>

Standard Adjustment

② Rear binder

© Lateral adjustment

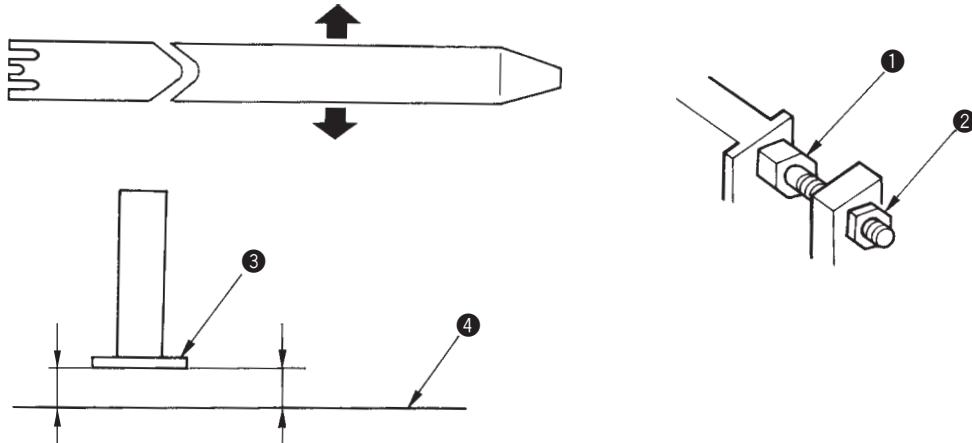

d Adjustment of height

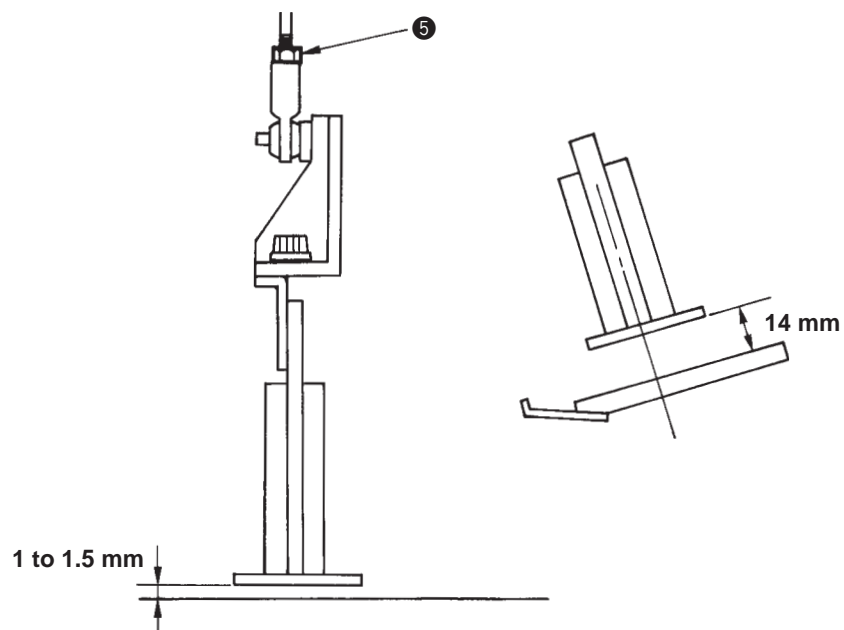

e Adjustment of welt patch clamp needle

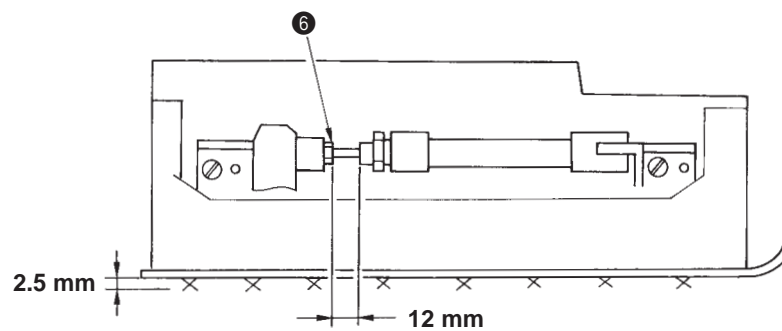

2) Clamp foot components

Standard Adjustment

① Adjusting the tension of the clamp foot traveling belt

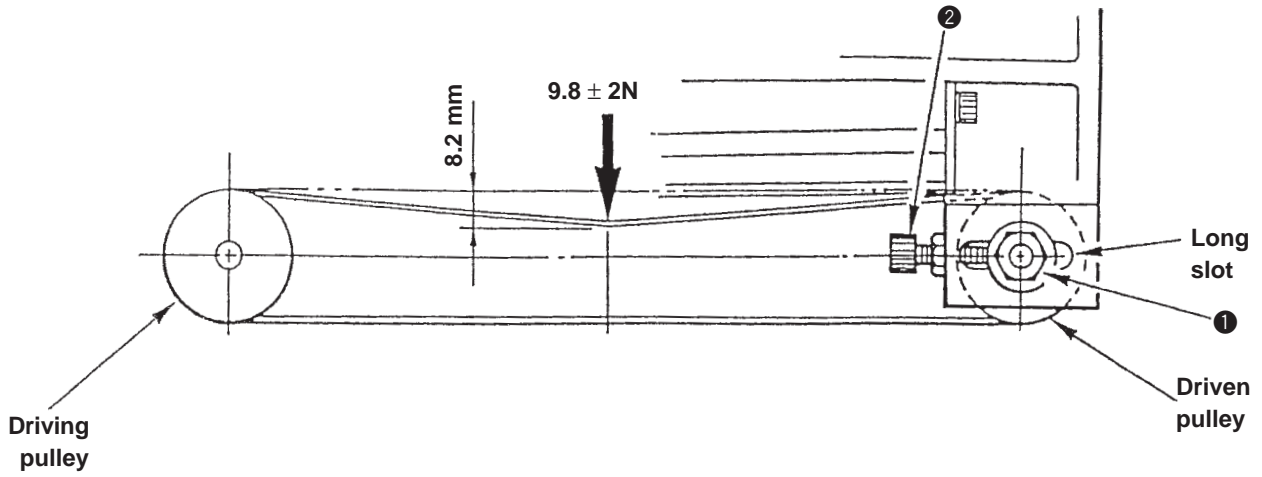

② Adjusting the tension of the clamp foot driving belt

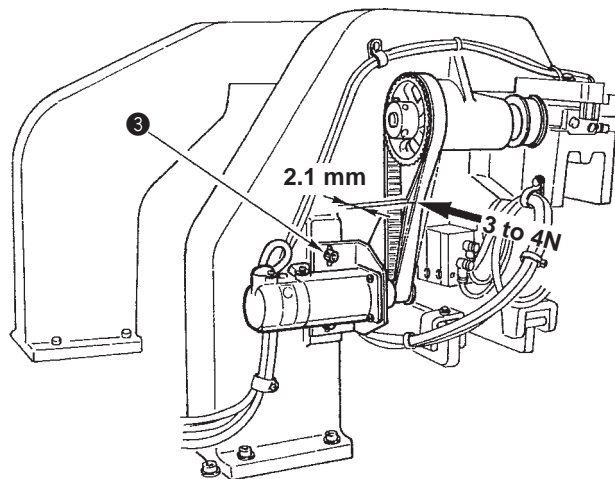

Adjustment Procedures	Results of Improper Adjustment
<p>○ The tension of the clamp foot traveling belt can be adjusted by loosening lock nut ❶ and shifting the driven pulley along the long slot. (The pulley can be shifted by moving adjusting screw ❷ back and forth.)</p> <p>The tension on the belt should be adjusted so that the middle of the belt slackens by approximately 8.2 mm when a pressure of 9.8 ± 2 N is applied.</p> <p>After making the adjustment, securely tighten lock nut ❶.</p>	<p>○ If the tension is excessively low, variation of sewing position or knife position is caused.</p>
<p>The tension of the clamp foot driving belt can be adjusted by loosening setscrew ❸ and moving the whole of motor bracket up and down.</p> <p>The tension on the belt should be adjusted so that the middle of the belt slackens by approximately 2.1 mm when a pressure of 3 to 4N is applied.</p> <p>After making the adjustment, securely tighten setscrew ❸.</p>	<p>○ If the tension is excessively low, variation of sewing position or knife position is caused.</p>

Standard Adjustment

③ Clamp foot front end stop position and rear end stop position

Standard distances for photosensor location

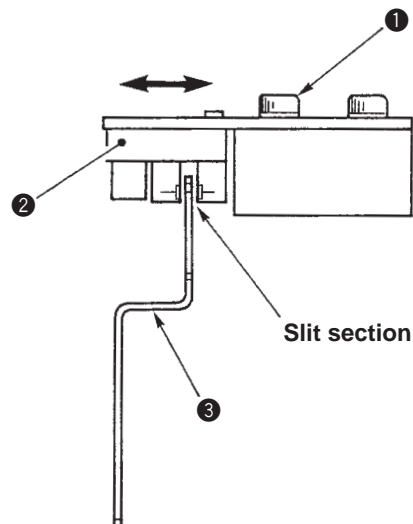
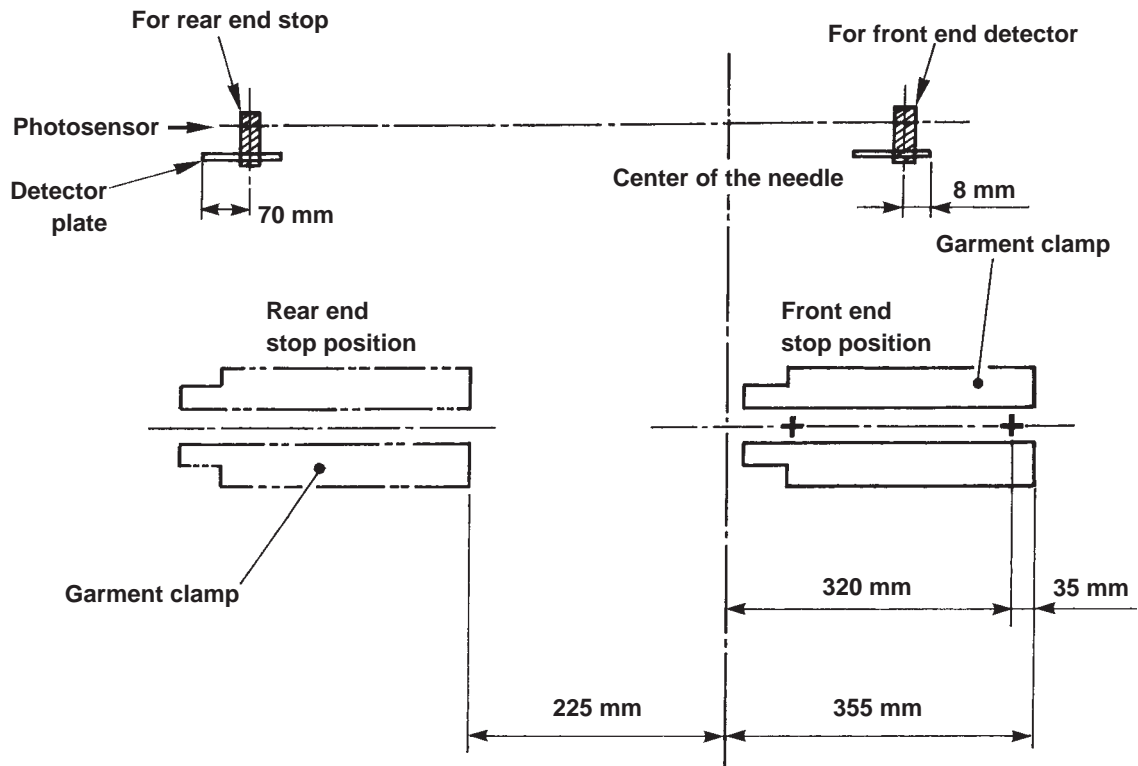

Standard Adjustment

④ Adjusting the garment clamp lifting amount

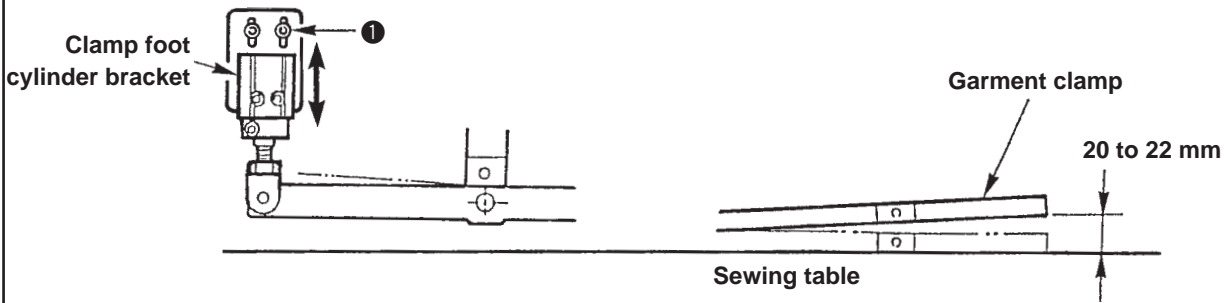

Ⓐ - Ⓑ = 0.2 mm or less

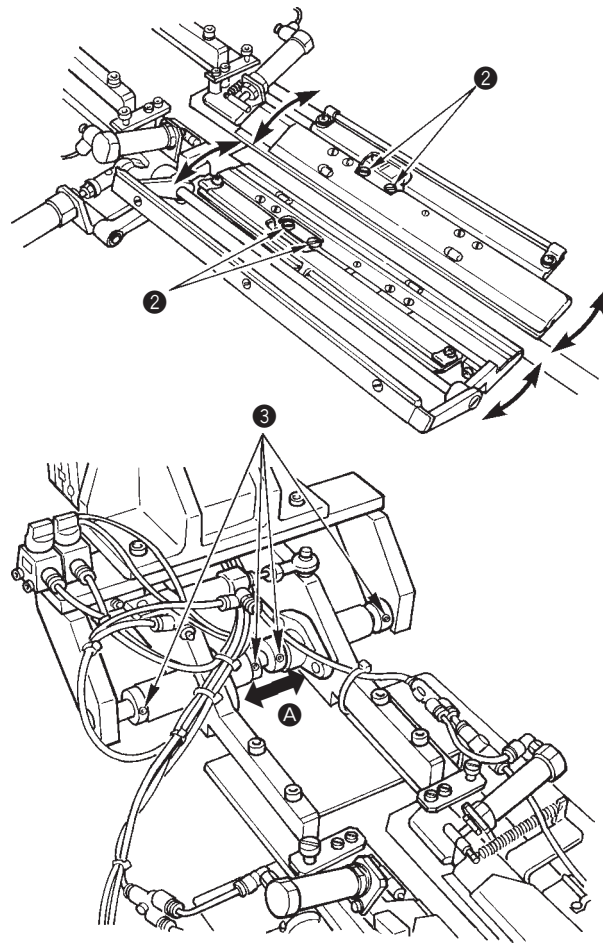
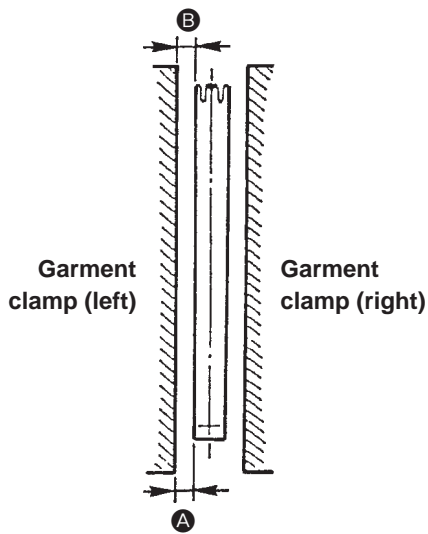

⑤ Adjusting the welt patch folding plate and the flap presser

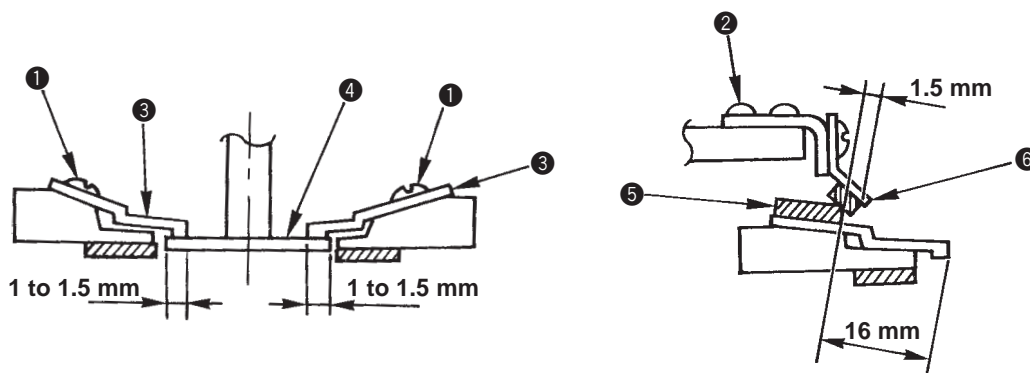

Adjustment Procedures	Results of Improper Adjustment
<p>④ Adjusting the garment clamp lifting amount</p> <ul style="list-style-type: none"> ○ The garment clamp, after the power is turned ON, goes up by means of the air cylinder. The standard lifting amount of the garment clamp is 20 to 22 mm from the surface side of the sewing table measured at the tip of it. Adjust the lifting amount by loosening setscrew ❶ in the clamp foot cylinder bracket, and move the whole of the air cylinder up or down. <p>The clearance between ❸ - ❹ must be kept in parallel to the welt patch base plate. Make sure that the difference between the front and rear ends of each garment clamp must not exceed 0.2 mm.</p> <p>If the clearance is not kept in parallel, loosen screws ❷, and move the garment clamp in the direction of arrow using the welt patch base plate as reference.</p> <ul style="list-style-type: none"> ○ Loosen screws ❸ and adjust so that the clearance between the garment clamp and the welt patch base plate should be 0.8 to 1.3 mm. 	
<ul style="list-style-type: none"> ○ Standard overlapping width of folding plate ❸ with welt patch base plate ❹ is 1 to 1.5 mm. ○ To adjust the overlapping amount, loosen setscrew ❶ and move folding plate ❸ properly. ○ The standard position of flap presser ❺ is where the top end comes out by 1.5 mm from the folding plate rubber ❻ (the rubber is pasted at the position which is 16 mm away from the top end of the folding plate). ○ To adjust the position of flap presser ❺, loosen setscrews ❷ and move flap presser ❺ properly. 	

3) Corner knife components

Standard Adjustment

① Corner knife mechanism of APW-297

[Operation of the corner knife]

Turn corner knife travel motor **a** ON, and moving corner knife **b** (sewing start position) will travel to the position which has been predetermined in accordance with the length to be sewn.

At the travel end position, the moving corner knife and fixed corner knife **c** (sewing end position) will be raised by each exclusive lifting air cylinders **d** and **e**, and cut a material.

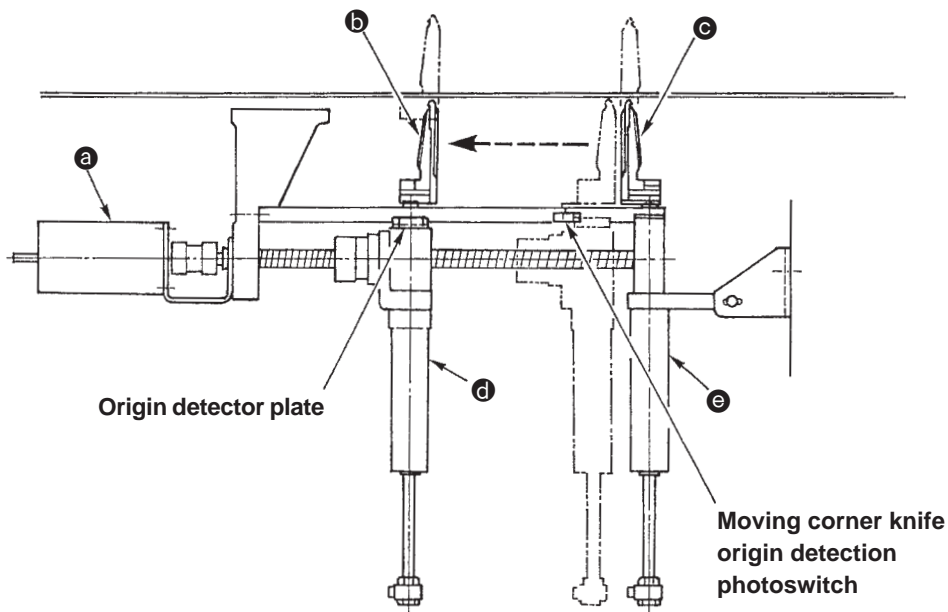

[Corner knife cutting position]

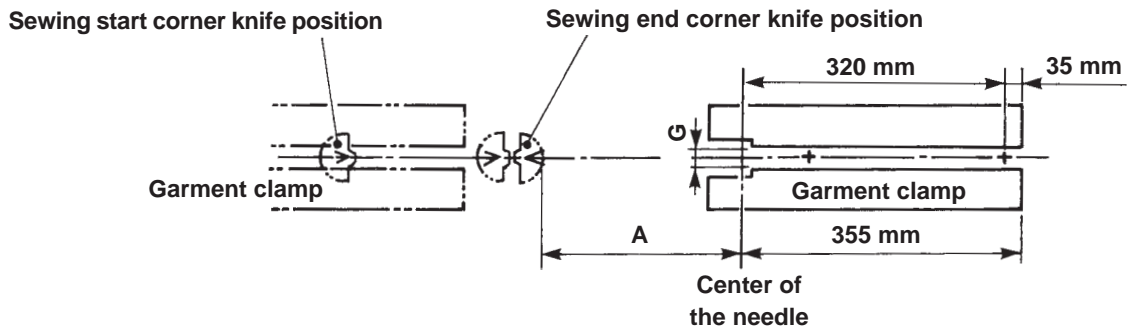

G	Gauge (mm)	10	12	14
A	Dimensions after assembled (mm)	129.9	127.4	124.4

Adjustment Procedures

Results of Improper Adjustment

- When the desired dimension cannot be obtained, loosen setscrew **f** to adjust the dimension.

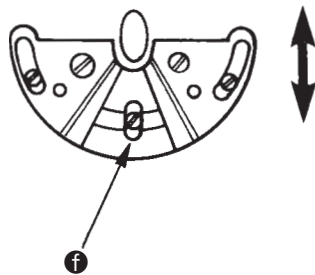

Standard Adjustment

Adjusting the clearance between fixed corner knife and moving corner knife

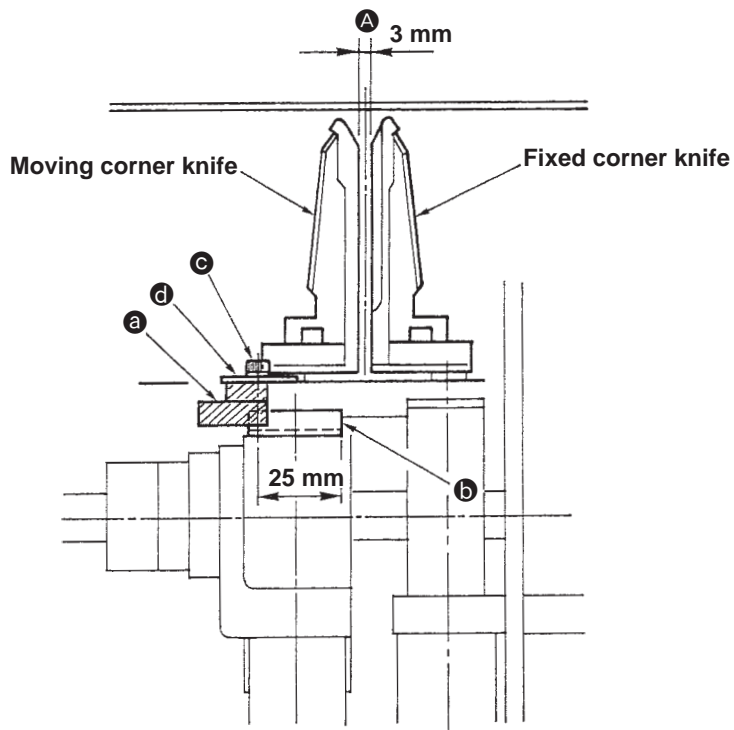

Adjusting the height of the corner knife

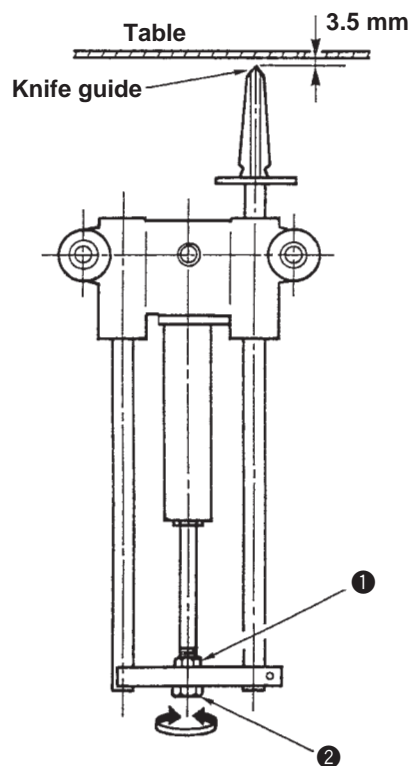

Standard Adjustment

② Corner knife mechanism of APW-298

[Operation of the corner knife]

Turn corner knife travel motor **a** ON, and moving corner knife **b** (sewing start position) will travel to the position which has been predetermined in accordance with the length to be sewn. At the travel end position, the moving corner knife and fixed corner knife **c** (sewing end position) will be raised by each exclusive lifting air cylinders **d** and **e** and cut a material.

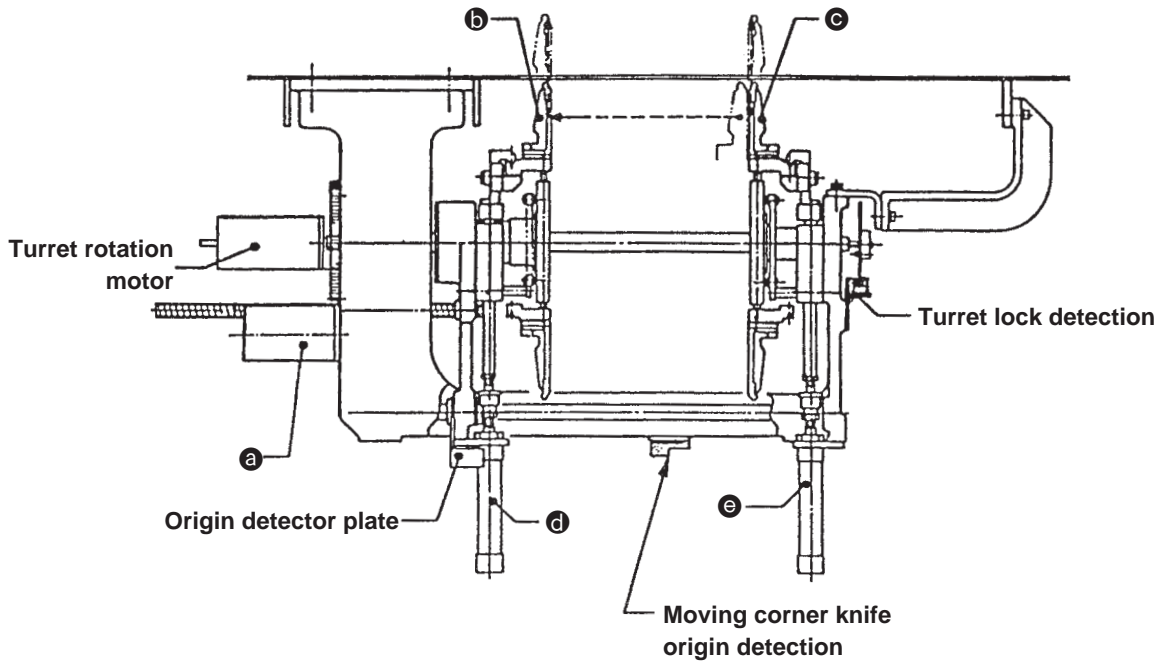

[Corner knife cutting position]

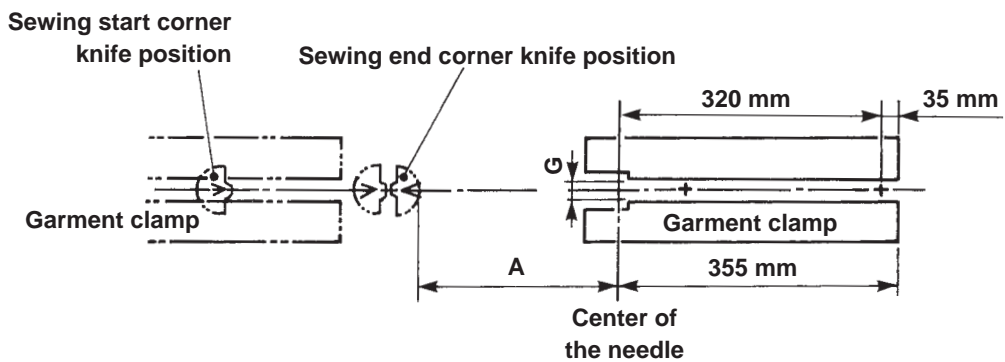

G	Gauge (mm)	10	12	14
A	Dimensions after assembled (mm)	200	196.3	192.5

Adjustment Procedures

Results of Improper Adjustment

- When the desired dimension cannot be obtained, loosen setscrew **f** to adjust the dimension.

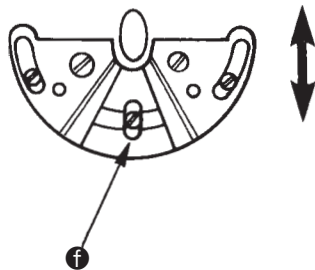

Standard Adjustment

Adjusting the clearance between fixed corner knife and moving corner knife

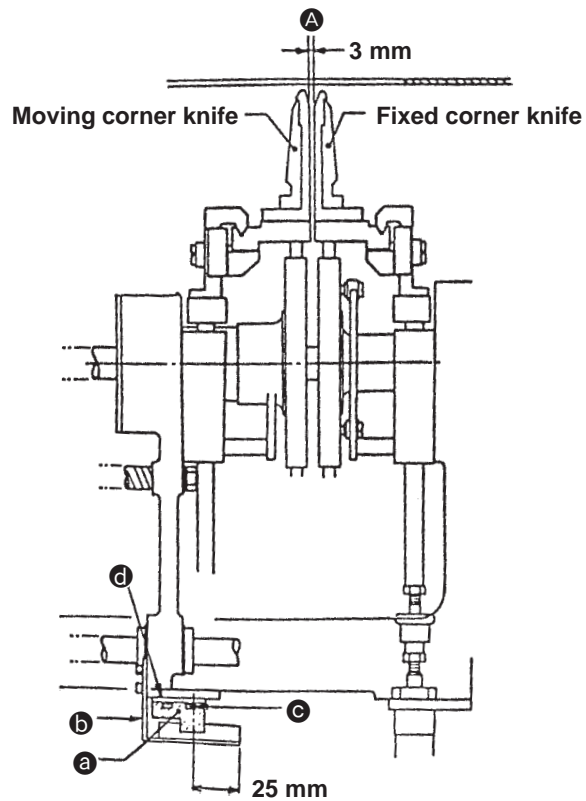

Adjusting the height of the corner knife

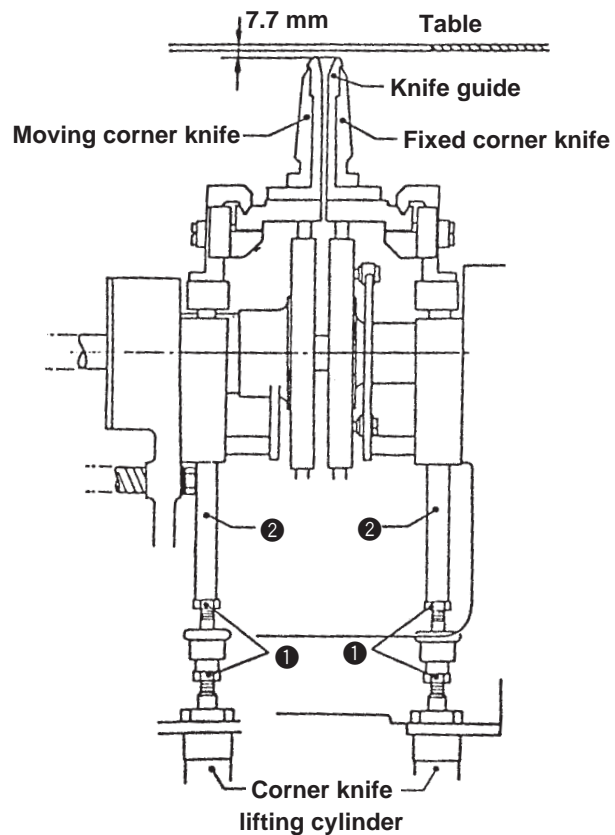

Adjustment Procedures	Results of Improper Adjustment
<ul style="list-style-type: none"> ○ Provide a clearance A of 3 mm between the fixed corner knife and the moving corner knife at the position of the origin as shown in the figure. The position of the origin of the moving knife is detected at the moment when the corner knife returns to its origin after having travelled. The corner knife stops after having travelled 25 mm from the point where photoswitch a detected detector plate b. At that time, clearance A is 3 mm. Adjust the moving corner knife by sliding switch attaching bracket d after loosening setscrew c. ○ When the corner knife lifting cylinder reaches its lowest position, there must be a clearance of 7.7 mm between the top ends of both moving corner knife and fixed corner knife and the surface side of the table as shown in the figure. This adjustment can be made by loosening lock nut 1 to adjust the screwing amount and moving the whole lifting rods 2 up or down. 	

Standard Adjustment

③ How to set the corner knife on the knife base wheel

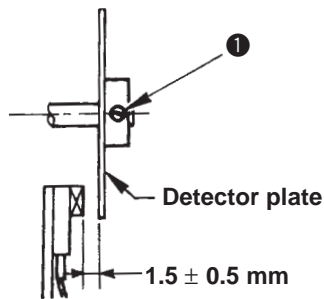
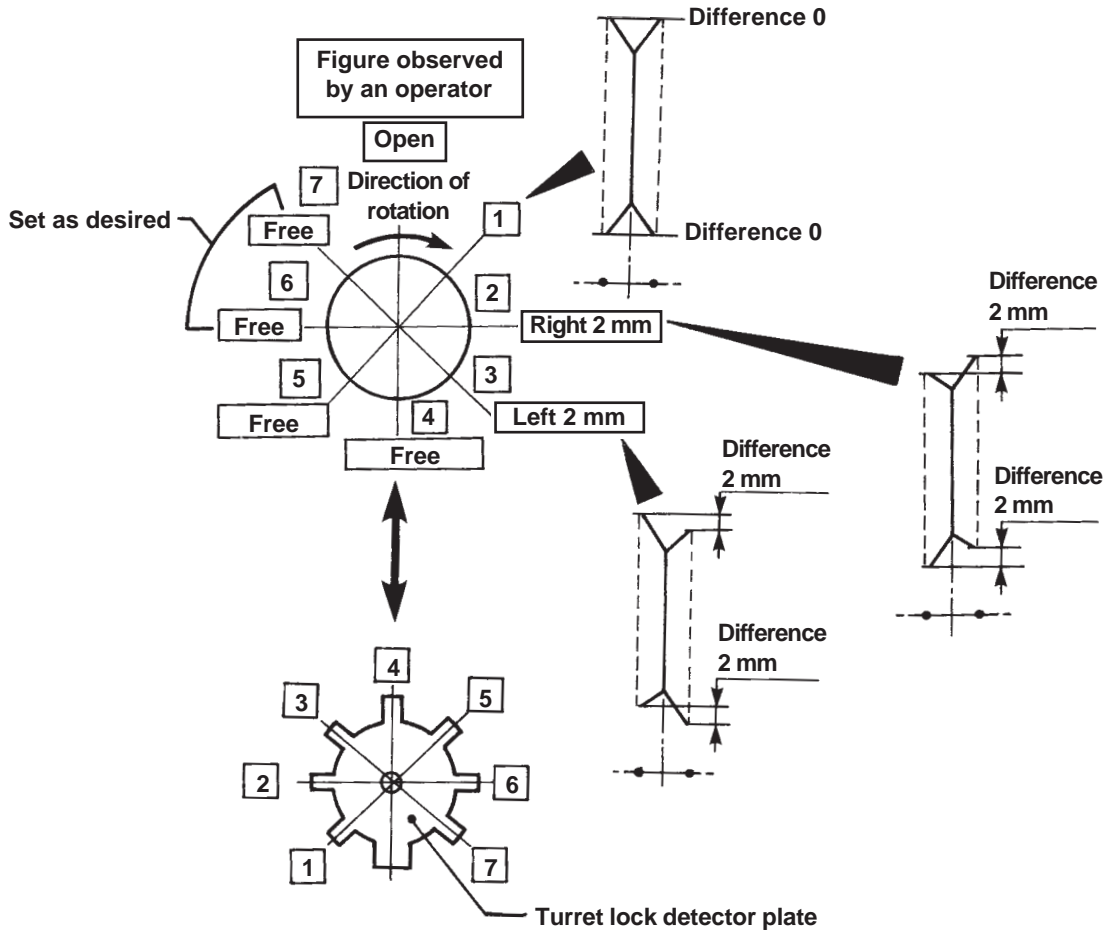

Adjustment Procedures	Results of Improper Adjustment
<ul style="list-style-type: none">○ Loosen setscrew ❶ and adjust the turret lock proximity switch so that a clearance of 1.5 ± 0.5 mm is provided between the switch and the detector plate.	

Standard Adjustment

④ Adjusting the center of the corner knife

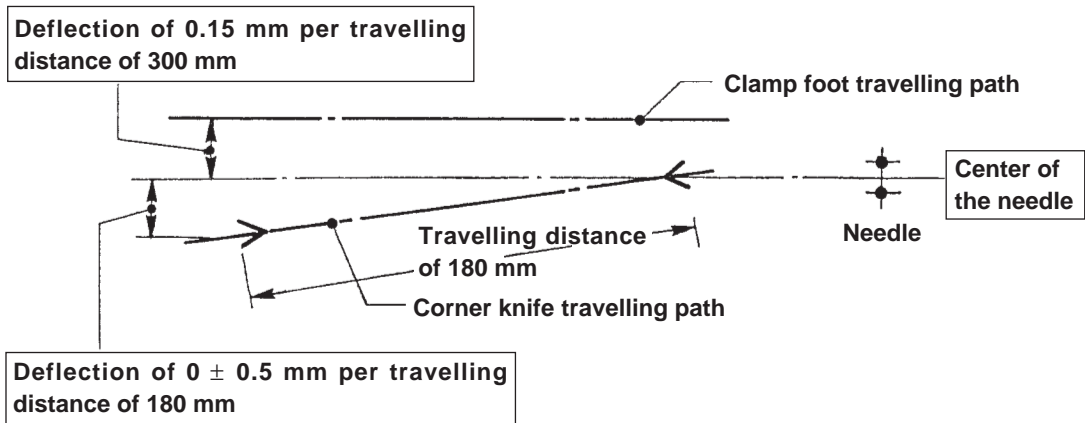

⑤ Adjusting the deflection and distortion of the corner knife

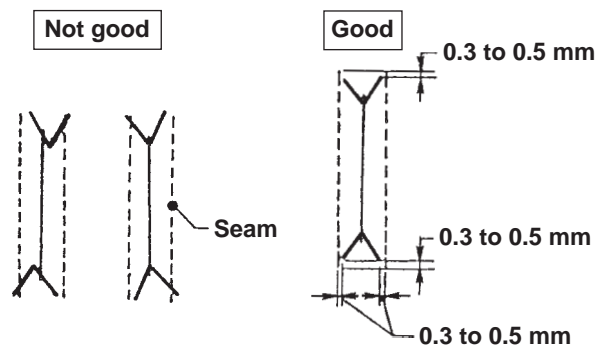

⑥ Adjusting the knife

Adjustment Procedures	Results of Improper Adjustment
<p>The center of the corner knife should be aligned with the center of the needle when the corner knife moves. Although the alignment is correctly adjusted at the time of delivery, in the event that the corner knife bracket is moved due to an external impact, loosen the bolt fixing the corner knife frame in place, and shake the whole corner knife bracket so that the clearance between the moving corner knife and the center of the needle is 0 ± 0.5 mm or less when the moving corner knife is moved approximately 180 mm. When adjusting the clearance by moving the corner knife bracket, be sure to loosen the setscrew in the fixed bracket supporting the opposite side of the shaft.</p> <p>○ If the corner knife is attached with deflected to right or left, or distorted, defective state of the cut part may result as illustrated in the figure on the left.</p> <p>The corner knife should always cut the center of the seams and should not cut the thread in the seam. Once the center of the corner knife has been correctly adjusted, only a fine adjustment will be required to attach a corner knife blade.</p> <p>When replacing or adjusting the corner knife, first move the clamp foot to its backward travel end using the CLAMP FOOT TRAVEL key on the operation panel, and secondly remove the sewing table and operate the corner knife elevating solenoid valve by hand to allow the corner knife to go up. Then take the below-stated steps of procedure.</p> <p>After the adjustment, carry out thorough-going tests to confirm that no faulty cut product is finished. Then start the sewing work.</p>	

Standard Adjustment

⑦ Adjusting the corner knife for parallel sewing

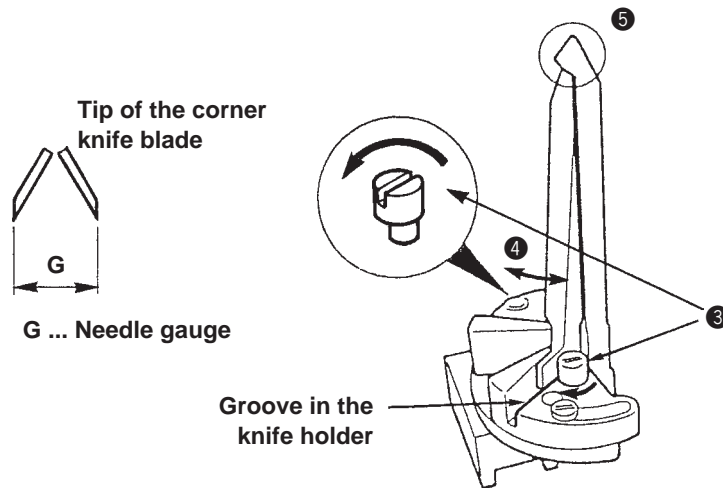
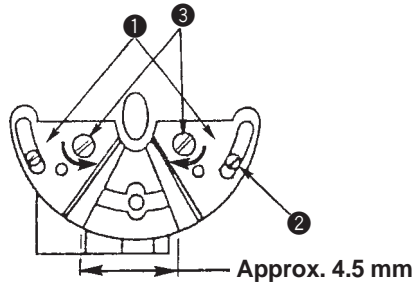

⑧ Fine adjustment of corner knife in terms of seams

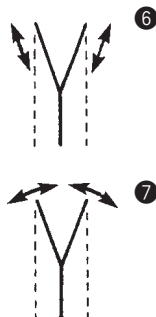

Adjustment Procedures	Results of Improper Adjustment
<p>○ The following description explains the adjusting method for the corner knife for parallel sewing which is the standard type of sewing.</p> <p>1) Adjust the opening amount of corner knife holders ❶ in the figure on the left to 4.5 mm and temporarily tighten screw ❷.</p> <p>2) Insert the corner knife into the groove in the corner knife holder as shown in the figure on the left. Position the corner knife so that the distance almost same as the needle gauge is provided between the tips of blades. Then fix the knife there by turning eccentric pin ❸ in the direction of the arrow. This temporarily fixes the corner knife. Then perform a trial stitching using the material to be sewn in the actual sewing, and finely adjust the installing position of the corner knife so that the notch matching the seam is obtained.</p> <p>1) Loosen eccentric pin ❸ shown in the figure given at the top of the previous page, and adjust the cutting length ❹ shown in the figure at the bottom of the previous page by moving the corner knife in the direction of arrow ❺.</p> <p>(Caution) When moving the corner knife, top end ❻ of the knife should be covered.</p> <p>2) Loosen screws ❷ shown in the figure at the top of the previous page, and adjust the angle of notch ❽ shown in the figure at the top of the previous page by changing the opening amount of the corner knife holders.</p>	

Standard Adjustment

⑨ Adjusting the corner knife for slant sewing

- When using the corner knife in the slant sewing with a difference, adjust the corner knife following the instructions described below, based on the aforementioned temporarily fixed position of the corner knife for parallel sewing.
- As an example, the adjusting procedure of corner knife adapting to the following sewing pattern is described.

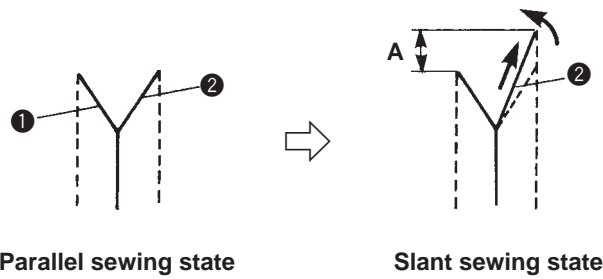
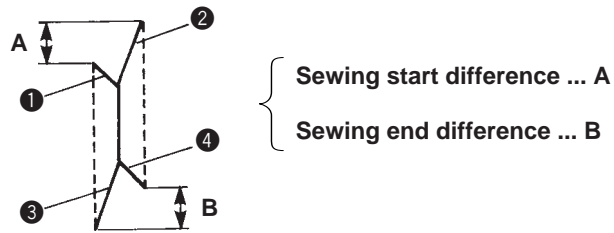

Make the blade protrude from the standard position by narrowing the angle of corner knife ②.

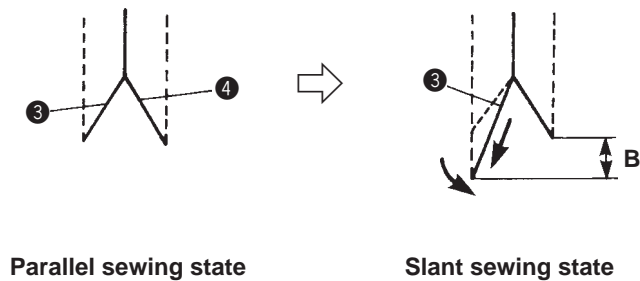

Adjustment Procedures	Results of Improper Adjustment
<p>1) To adjust the corner knife to sewing start difference A, corner knife blade ❶ on the left-hand side should be kept in the parallel sewing state as illustrated in the sketch on the left, and corner knife blade ❷ should be moved to extend the cutting length in accordance with the difference as illustrated in the sketch on the right. (Follow the procedure same as that described on the next page.)</p> <p>2) The corner knife is adjusted to rear difference B in the similar manner. Only corner knife blade ❸ should be moved to extend the cutting length in accordance with the sewing end difference. After the completion of the adjustment, finely adjust knife blades ❶, ❷, ❸ and ❹ in accordance with the seam in the procedure sama as that described on the next page. The corner knife can be adjusted by extending the cutting length of the longer seam regardless of the kinds of slant sewing.</p>	

(3) Optional components

1) Welt patch cut unit (right) : SA102

Standard Adjustment

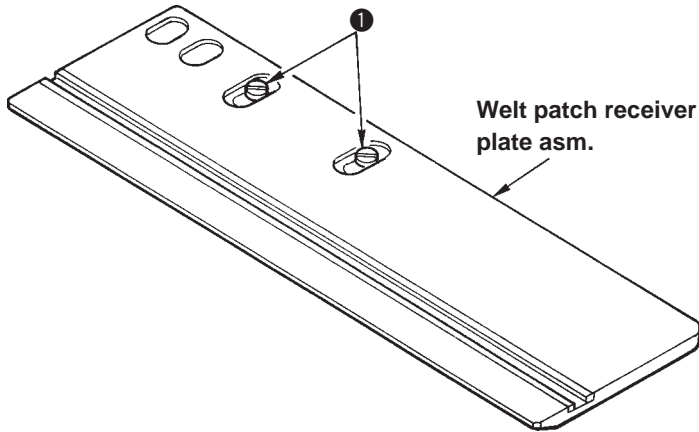

Welt patch whose front and rear sides are cut should be aligned with the cutting position of the center knife.

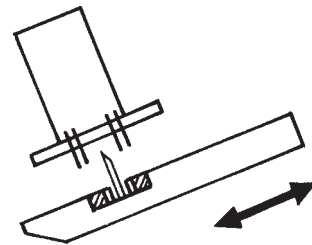
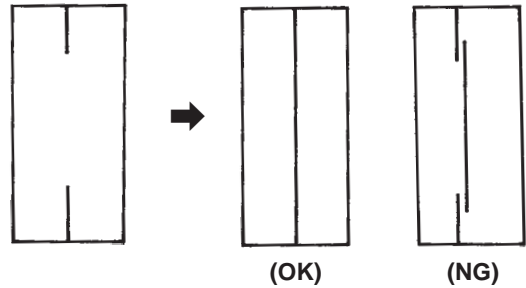
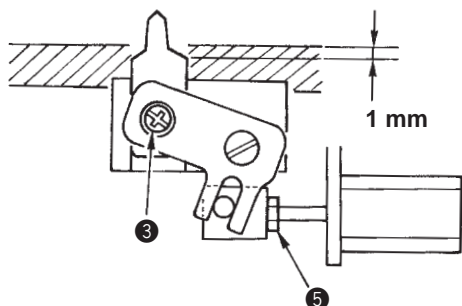
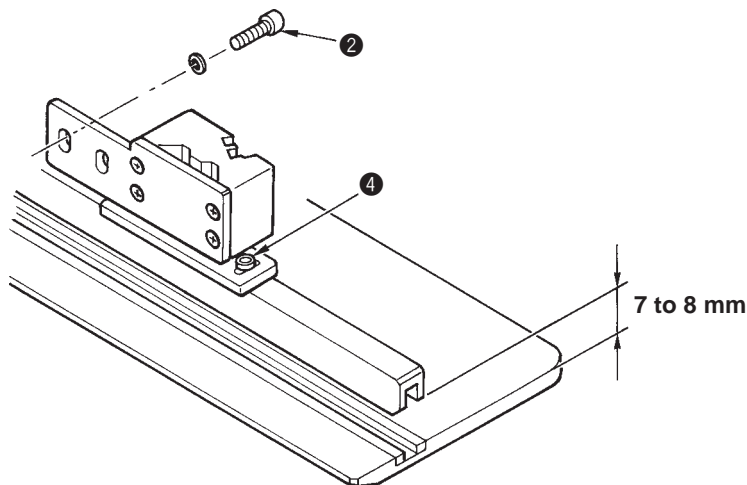

Figure (a)



The lifting position of the welt patch cut knife is where the blade end of the knife is lower 1 mm from the top surface of sponge rubber.

* Expel the air with the finger valve located in the rear of the power switch, loosen screw ③, and pull out the knife upward to replace the knife.

(Be careful of the direction of the knife blade.)

* The blade section is on the left-hand side as observed from the front.

Adjustment Procedures	Results of Improper Adjustment
<p>○ The centers of welt patch holding plate asm. and binder asm. should be aligned with each other. Welt patch cut knife in terms of welt patch clamp needles should be positioned in the center.)</p> <p>⇒ If not, loosen screw ❶ to adjust the position of welt patch holding plate.</p> <ol style="list-style-type: none"> 1) Make the welt patch clamp needles appear in the state of the binder with swung and set the binder lifting cylinder to air-free state. 2) Lift the binder by hand and make the welt patch cut knife appear. Then checking with the naked eye the clearance between the knife and the welt patch clamp needles at the longitudinal position of the knife, adjust the clearance. (Figure (a)) < Perform the aforementioned checking by operating the solenoid valve by hand.> <p>(Caution) Perform the aforementioned adjustment after adjusting the welt patch width.</p> <p>○ Welt patch cut presser</p> <ul style="list-style-type: none"> • Welt patch cut presser should be positioned 7 to 8 mm away from the welt patch receiver plate. • Welt patch cut knife should be positioned in the center of groove of the welt patch cut presser. • When the welt patch is pressed by the welt patch cut presser, the pressing pressure should be equal longitudinally and laterally. <ol style="list-style-type: none"> 1) Adjust the vertical position and longitudinal pressing pressure of the welt patch cut presser by loosening two screws ❷. 2) Adjust the lateral direction of the welt patch cut presser by loosening two screws ❸. <ol style="list-style-type: none"> 3) Adjust the protruding amount by loosening nut ❹ at the top end of the cylinder and turning the cylinder rod. 	<p>○ If the cutting position of front and rear of the welt patch is not in the center, the unevenness of left/right welt patch widths is caused. Further, in the worse case, welt patch supply failure is caused.</p> <p>○ If the pressing pressure is uneven, welt patch cut failure or occurrence of small wrinkle at the time of welt patch cut is caused.</p> <p>○ If the protruding amount of the knife is excessively large, welt patch cut failure is caused.</p>

Standard Adjustment

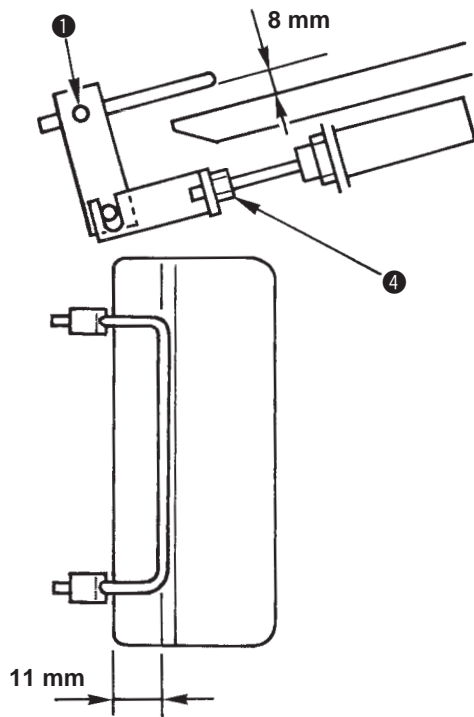

- Lifting amount of the welt patch cut presser should be 8 mm from the welt patch receiver plate.

- Position of the welt patch cut presser should be 11 mm from the edge of the welt patch receiver plate.

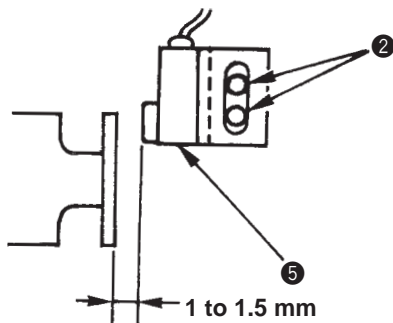

Clearance between the detector plate and origin sensor ⑤ is 1 to 1.5 mm.

Sensor should be turned ON in the state that the sensor travel base travels to the operator's side until it will go no further and collides with knife travel base (B).

Single welt and double welt changeover switch

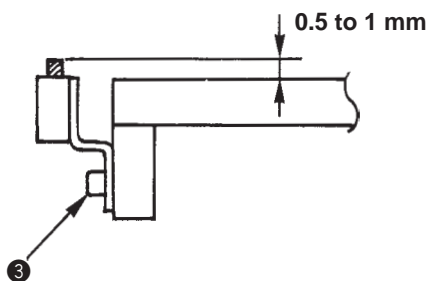

The switch should protrude 0.5 to 1 mm from the top surface of the welt patch receiver plate.

2) Flap supply unit (left) : SA103

Standard Adjustment

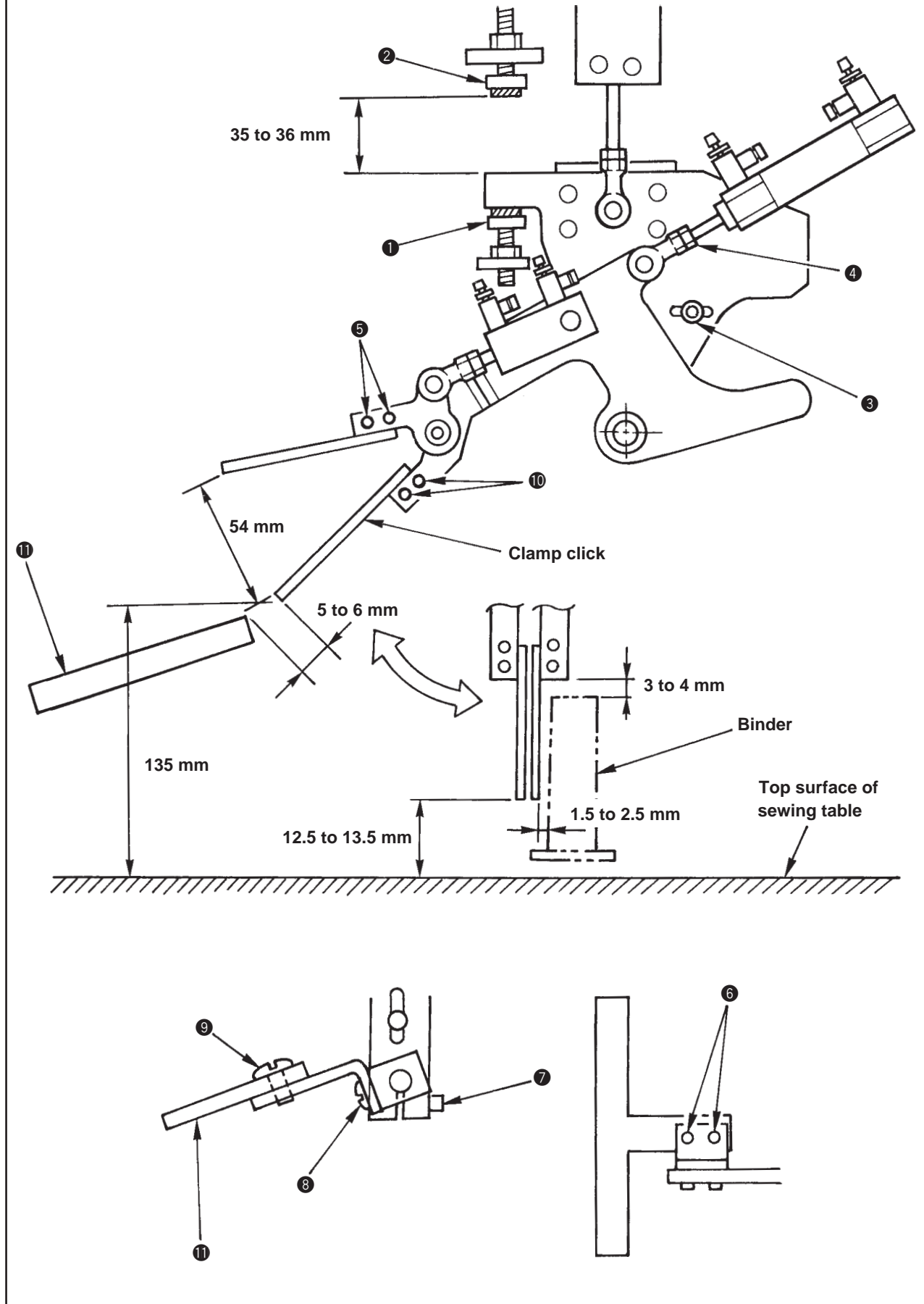

Adjustment Procedures	Results of Improper Adjustment
<ol style="list-style-type: none"> 1) Adjust with stopper ❶ the clearance (3 to 4 mm) in the height direction between the clamp click and the binder when the clamp click comes down. 2) Adjust with stopper ❷ the vertical travel amount of the flap supply unit. 3) Adjust the clearance (12.5 to 13.5 mm) between the clamp click and the sewing table by loosening screws ❸ and ❹. (To be equal in the longitudinal direction) 4) Adjust with stopper ❸ the clearance between the side face of the binder and the clamp click when the clamp click comes down. 5) Loosen nut ❺ in the oscillating cylinder and adjust the height (135 mm) of the clamp click from the top surface of the sewing table when the clamp click returns to the position of the receiver plate. 6) Adjust the clamping pressure of the clamp click by loosening screws ❻. 7) Adjust the parallel of the clamp click to the sewing table by loosening screws ❼. 8) Adjust the angle of flap receiver plate ❾ by loosening screw ❽. Adjust the longitudinal inclination of the flap receiver plate ❾ by loosening two screws ❿. Adjust the clearance (5 to 6 mm) between the flap receiver plate ❾ and the clamp click by loosening two screws ⓫. 	<ul style="list-style-type: none"> ○ If the clearance between the clamp click and the sewing table is excessively small, the clamp click interferes with the flap presser or the rubber on the folding plate. ○ If the clearance between the clamp click and the sewing table is excessively large, there is a danger that the finished size of the flap varies.

3) Flap and bag cloth supply unit (left) : SA104

Standard Adjustment

○ Origin slit should be positioned 15.8 mm from the flap receiver plate.

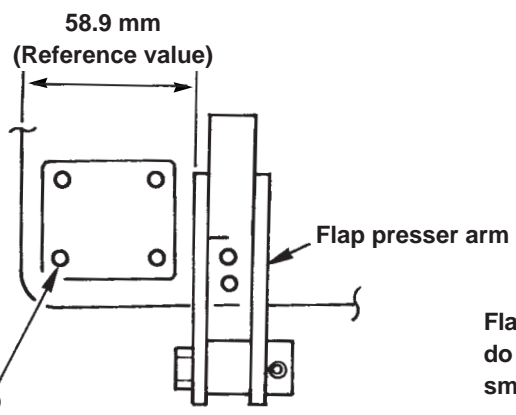
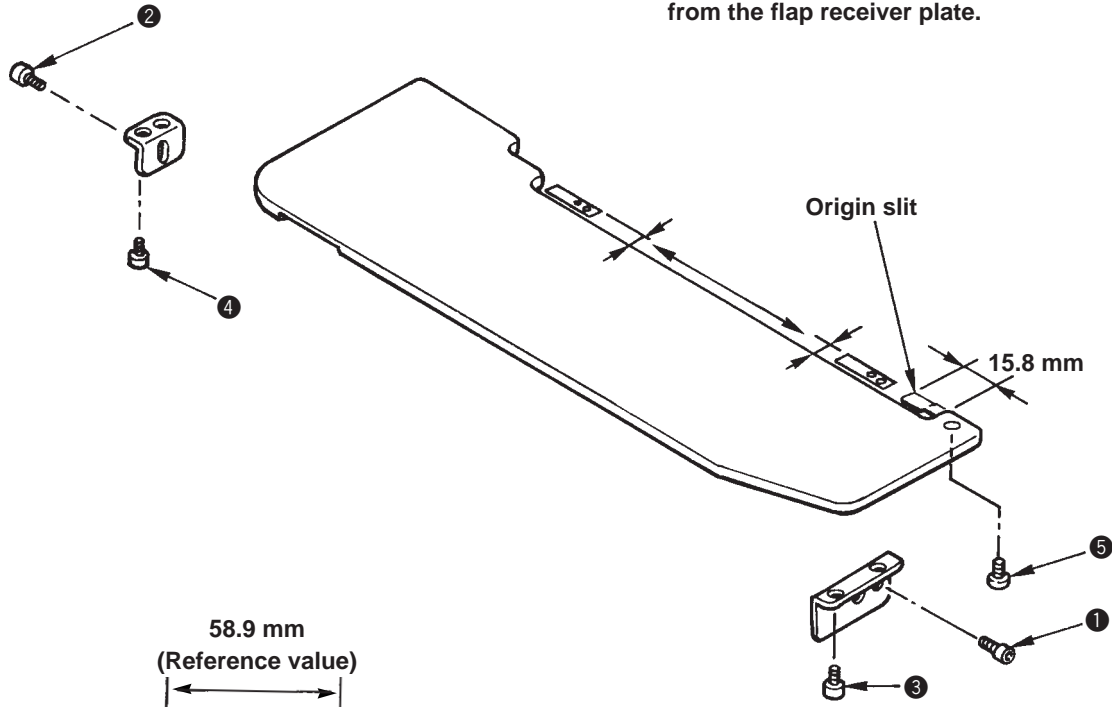

Flap presser arm and presser arm driving cylinder do not interfere with each other, and should move smoothly.

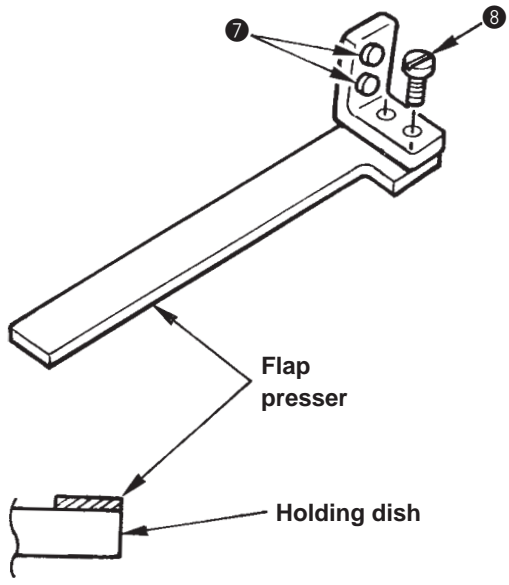

Press the flap presser uniformly.

Align the flap presser with the edge of the holding dish to install it.

Standard Adjustment

(a) Adjustment of the sensor slit

- Position of the origin slit ① is 15.8 ± 0.3 mm away from holding dish ②.

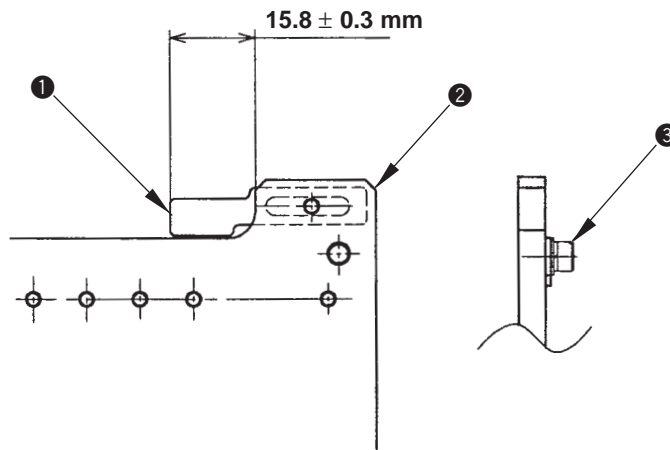

(b) Adjustment of belt tension

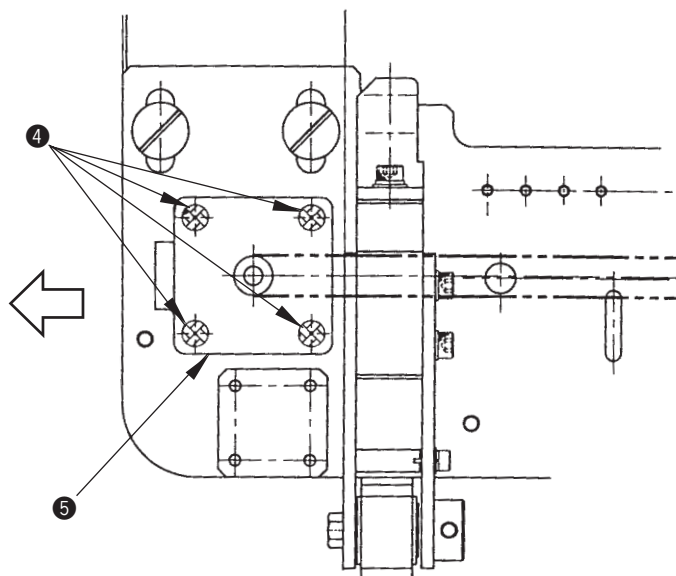
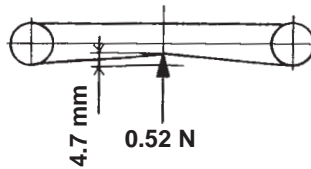

Standard Adjustment

(c) Adjustment of flap presser

- Distance from flap presser arm ① to the edge of holding dish ② is (58.9 mm). (Reference value)
In addition, install so that flap presser arm ① and the edge of holding dish ② should be almost parallel.
- Pressure on the top end side of flap presser ③ is low and the flap presser is installed slightly slantingly.

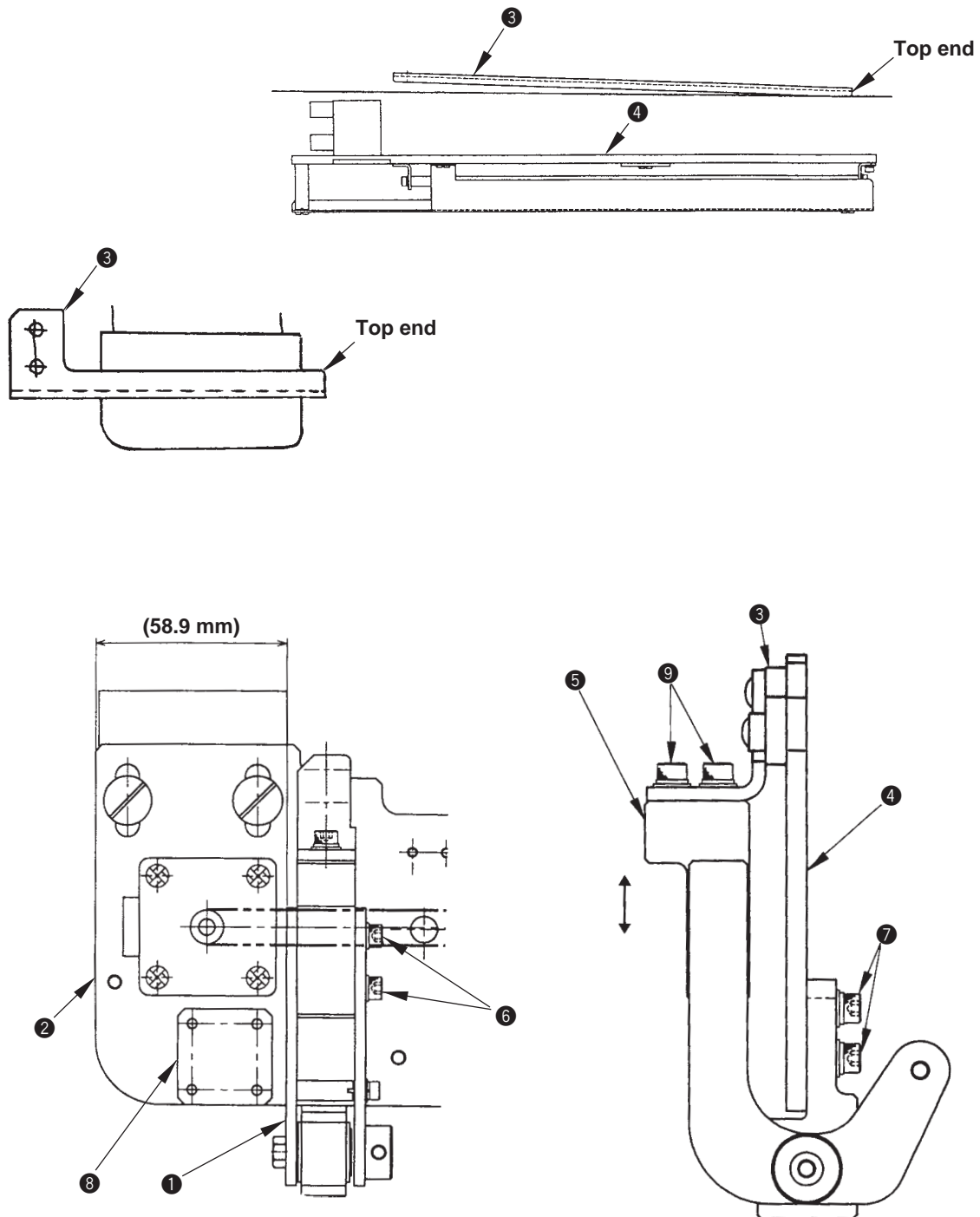

Adjustment Procedures	Results of Improper Adjustment
<p>1) Loosen two setscrews ⑦ in the flap presser rotating base to adjust the flap presser.</p> <p>Note) At this time, check that flap presser cylinder ⑧ moves smoothly. (Expel air from the cylinder to check.)</p> <p>2) Loosen two setscrews ⑥ in the flap presser base, move flap presser base ⑤ in the direction of the arrow, and adjust so that flap presser ③ is aligned with the edge of holding dish ④.</p> <p>3) Loosen two setscrews ⑨ in the flap presser and install flap presser ③ slightly slantingly to increase the pressure on the top end side of flap presser ③.</p>	<ul style="list-style-type: none"> ○ Flap is not pressed or flap may slip at the time of delivery of flap.

Standard Adjustment

(d) Adjustment of flap holding dish

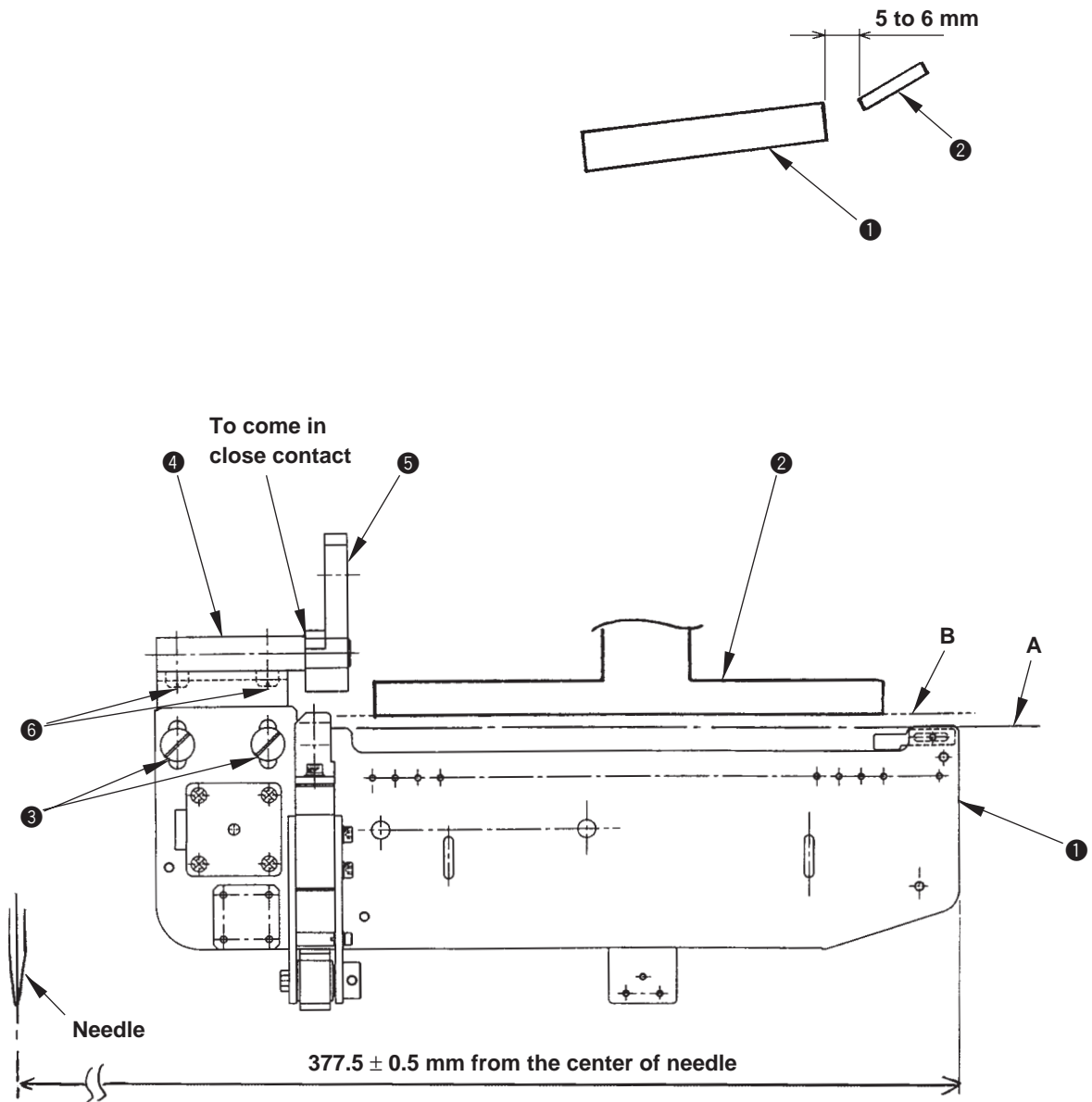

Adjustment Procedures	Results of Improper Adjustment
<p>1) Loosen two setscrews ③ in the flap holding dish and adjust so that the clearance between flap holding dish ① and clamp nail ② is 5 to 6 mm and so that the edge A of flap holding dish ① is parallel to the edge B of clamp nail ②.</p> <p>2) Loosen two setscrew ⑥ and adjust the flap holding dish to 377.5 ± 0.5 mm away from the center of the needle. (At this time, make holding plate fitting shaft ④ come in close contact with shaft base ⑤.)</p>	<ul style="list-style-type: none"> ○ When the clamp nail is not in parallel to the flap holding dish, the flap is sewn slantingly. ○ The sewing position of the flap in the lateral direction may slip.

4) Dart extending unit : SA106

Assembling procedure

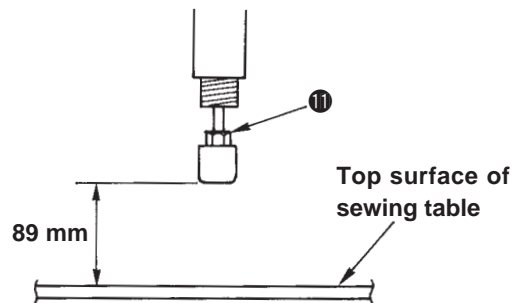
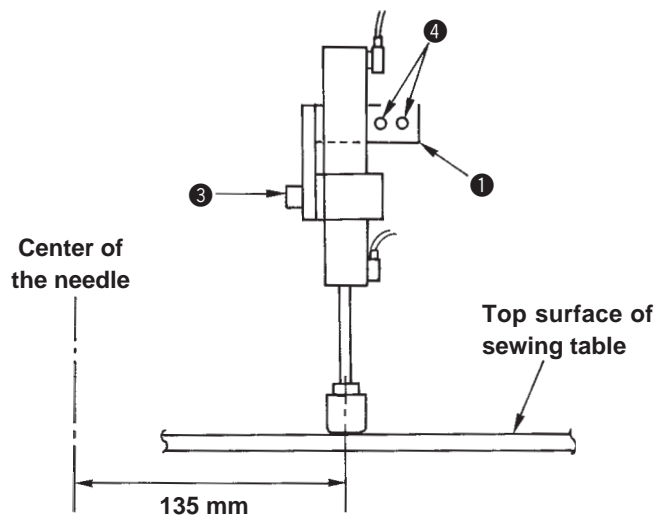
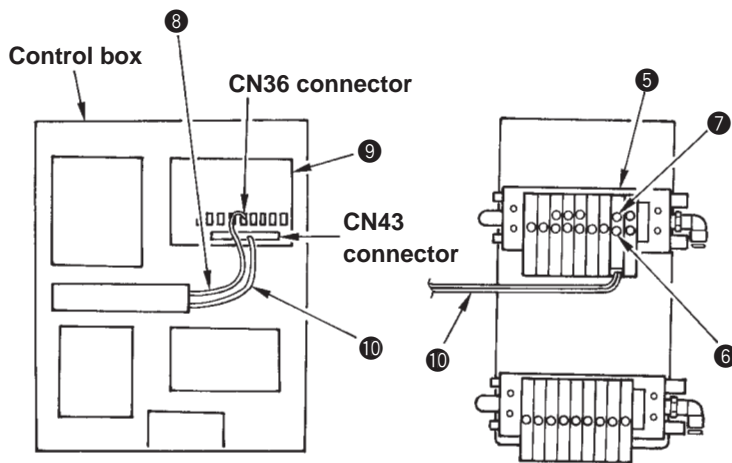
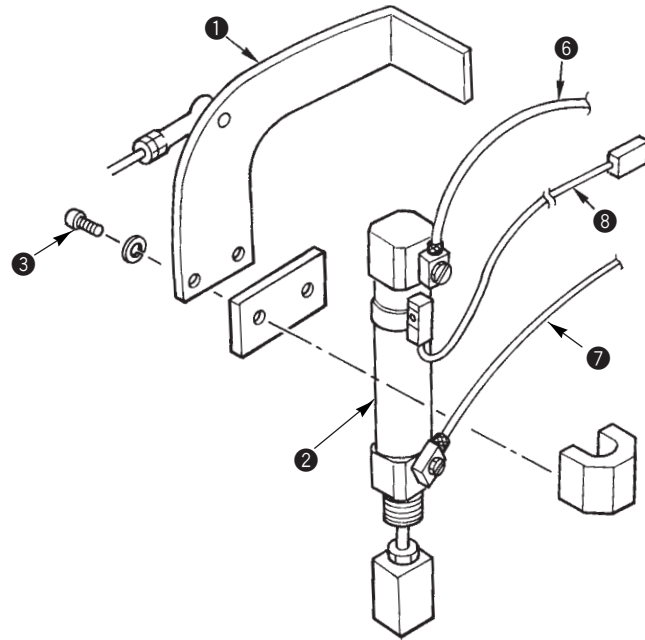

Assembling procedure	Caution when assembling
<p>○ Connect dart extending cylinder ❷ to connecting plate ❶ with the screws as shown.</p> <p>○ Install the solenoid valve for dart extending ❺ with the screws at the second place from the right side of the upper manifold while inserting a packing between the valve and manifold.</p> <p>• Piping Connect the air tubes of $\varnothing 4$, green ❻ and yellow ❼, located on the side of dart extending cylinder to the joint of the solenoid valve.</p> <p>• Wiring Connect the connector of the dart upper detection sensor ❸ to CN36 located on MAIN circuit board ❾. Insert the pins of the solenoid valve cable ❿ into No. 45, +24V and No. 46, Dart output of the connector CN43.</p> <p>1. Position of the dart extending Determine the center at the position of 135 mm from the center of the needle. If the 135 mm is not obtained, loosen screws ❹ in connecting plate ❶ to adjust the position. The presser of the dart extending should press the upper part of the center of the needle. Adjust the lateral direction by loosening screw ❸.</p> <p>2. Loosen nut ❾ and adjust the height of the dart extending so that it is 89 mm from the top surface of the sewing table.</p>	<p>○ When the screw is excessively tightened, malfunction of the cylinder is caused.</p>

5) Suction unit : SA108

Assembling procedure

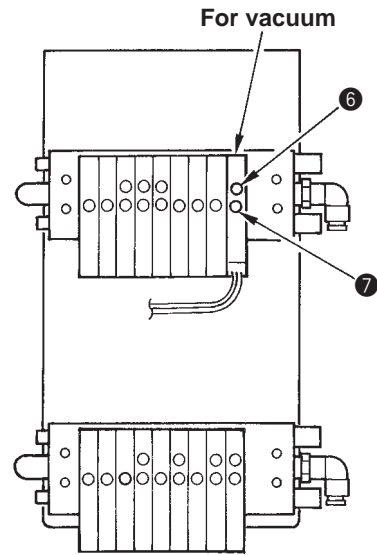
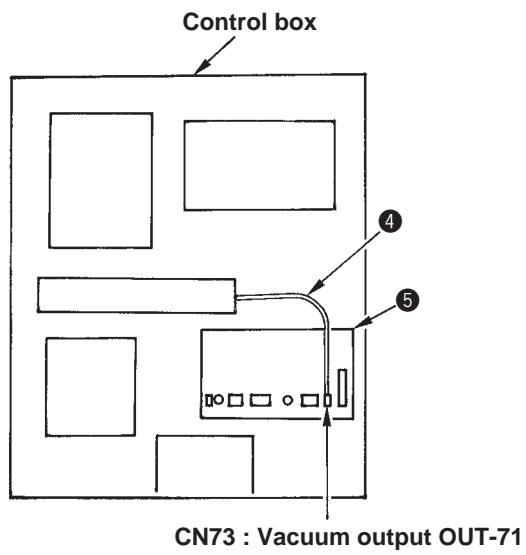
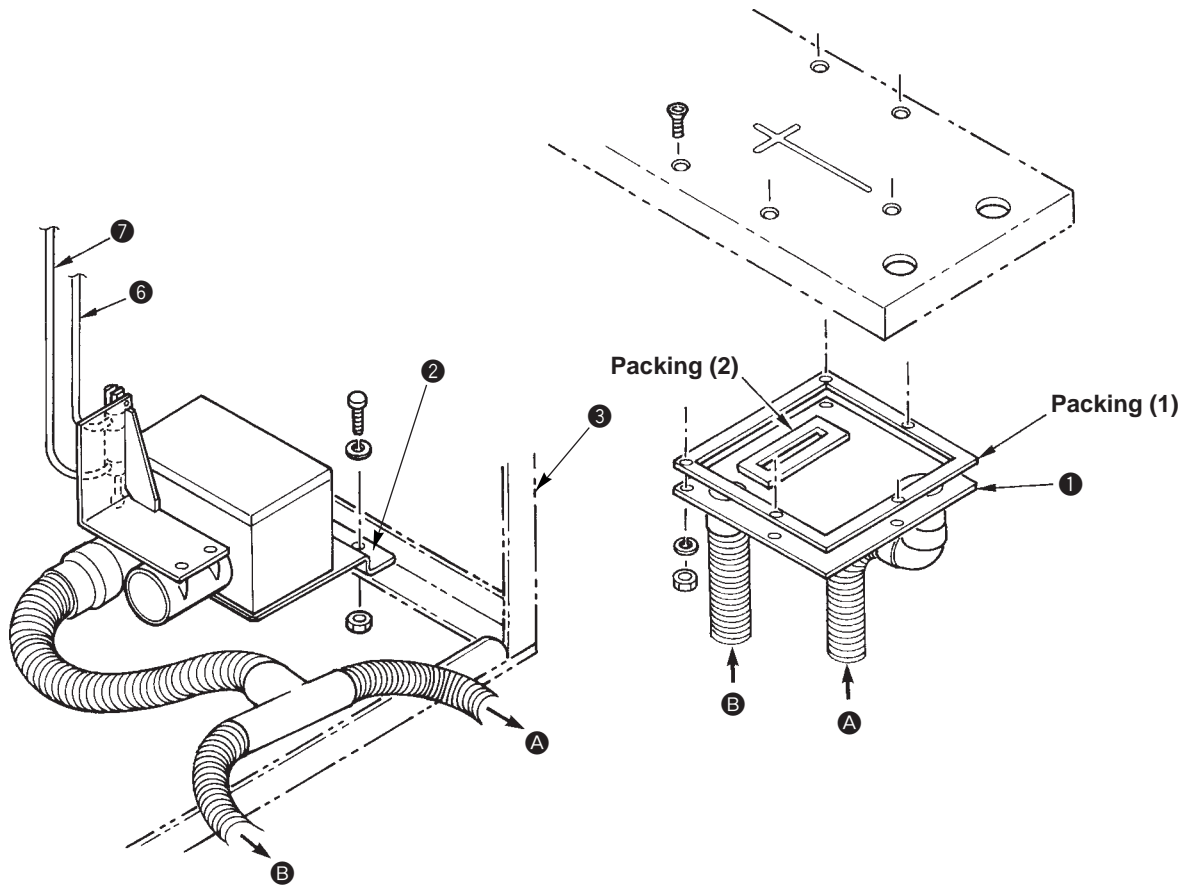

6) Interlining feeding unit : SA109

Assembling procedure

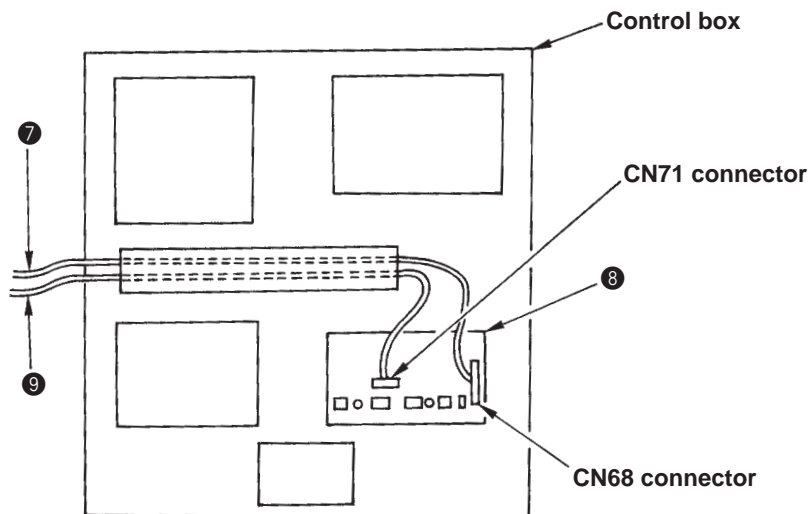
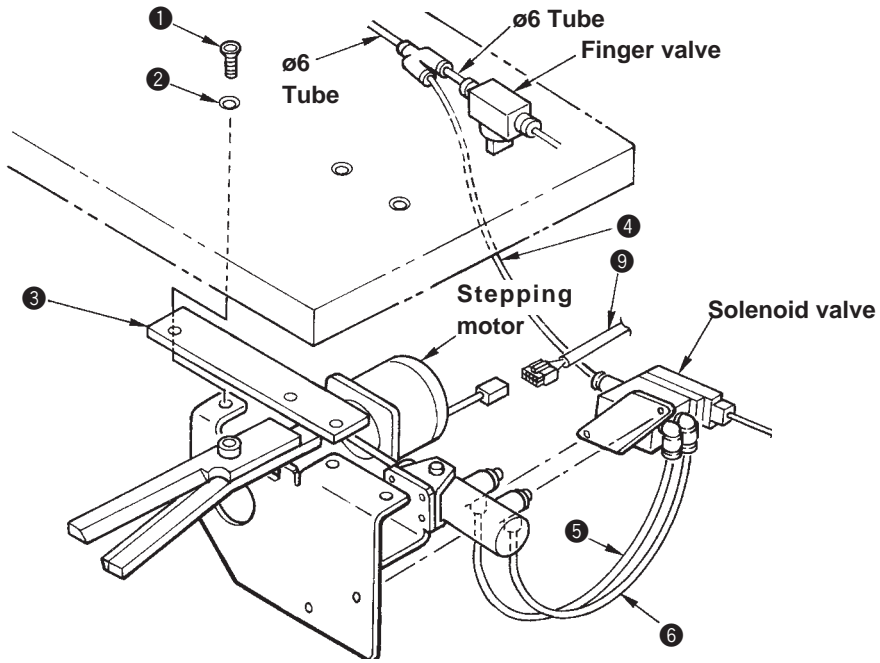

Assembling procedure	Caution when assembling
<p>○ Attach the interlining feeding unit body from the top surface of the table with screws ① and nuts ② (3 places). (In this case, place a spacer ③ between the body frame and the interlining feeding unit and fix the unit. In case of the machine with the vacuum unit, the spacer is not necessary.)</p> <p>Piping</p> <p>○ Connect ø6 Blue tube ④ to the solenoid valve from the air supply tube of the solenoid valve located at the power switch bracket section located under the right-hand bottom of the table. Connect ø4 Yellow ⑤ and ø4 Green ⑥ tubes to the cylinder for scissors drive.</p> <p>Wiring</p> <p>○ Insert +24V cable of solenoid valve cable for scissors drive ⑦ to No. 35 of CN68 connector on I/O circuit board ⑧ inside the control box and insert the output cable to No. 36 of CN68 connector.</p> <p>○ Insert automatic interlining feeding cable ⑨ of the stepping motor for interlining feeding to CN71 connector on I/O circuit board ⑧.</p>	

Standard Adjustment

Interlining feeding unit <SA109>

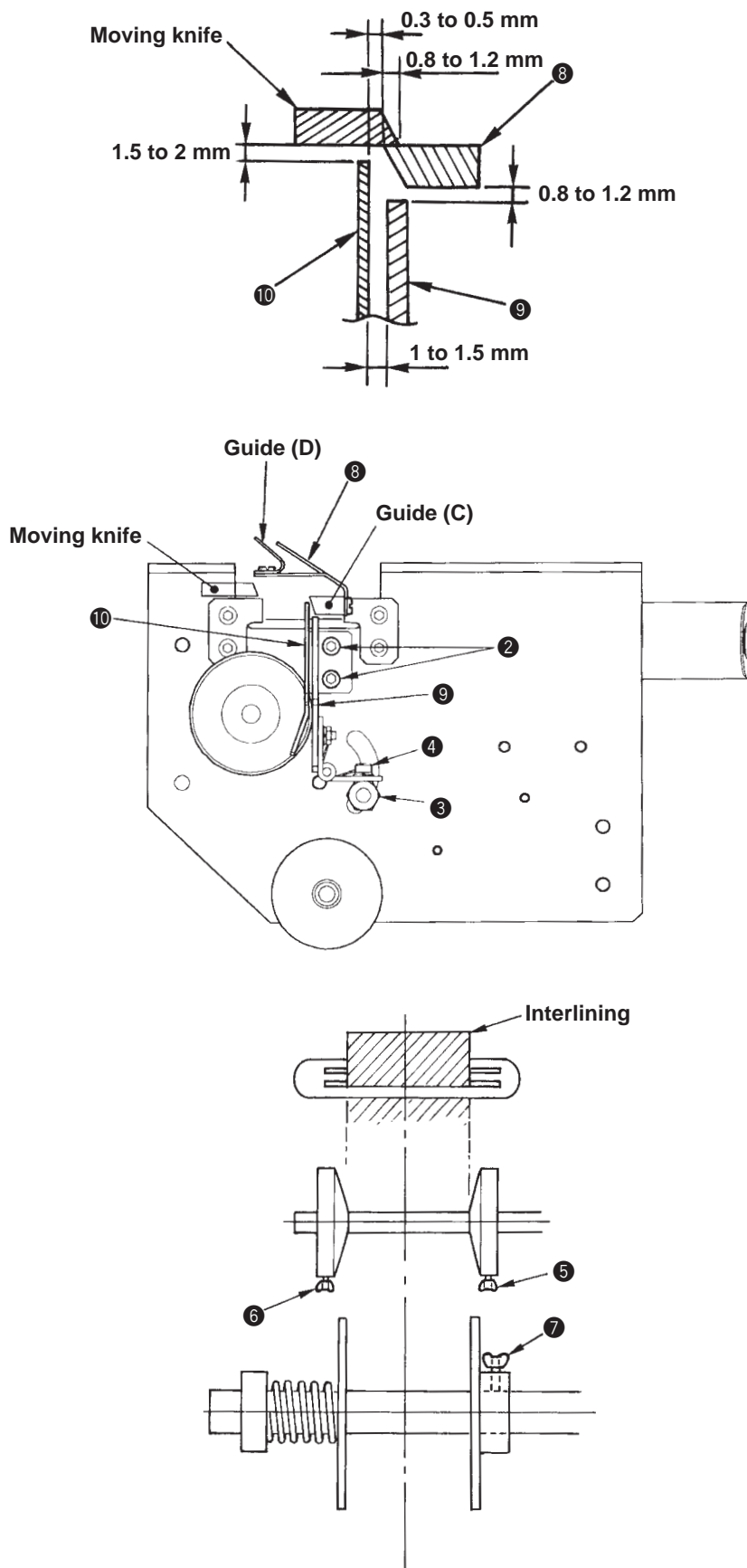

Adjustment Procedures

Results of Improper Adjustment

- 1) Position of guide A ⑩ in terms of fixed knife ⑧ should be 0.3 to 0.5 mm away from the blade point and 1.5 to 2 mm away from the top surface of the blade. When the position is not obtained, loosen screws ② to adjust the position.
- 2) Top end of guide B ⑨ should be in the position of 0.8 to 1.2 mm from the bottom face of fixed knife ⑧. When the position is not obtained, loosen screw ③ to adjust the position.
- 3) Guide A ⑩ and guide B ⑨ should be parallel and perpendicular each other. If they are not parallel, adjust them by loosening screw ③.
- 4) Provide a clearance of 1 to 1.5 mm between guide A ⑩ and guide B ⑨. If not, adjust it by loosening screw ③.
- 5) Length of engagement of scissors on the fixed side and that on the moving side should be 0.8 to 1.2 mm at the top end.
- 6) Loosen screw ④ and adjust pressing pressure of guide B ⑨ so that it is equal at the left end and right end of the interlining feeding roller.
- 7) Rolled interlining should be fed to the center through the slot section of the table.
Loosen screws ⑤, ⑥ and ⑦ for fixing guide to adjust the guide in accordance with the width of the interlining.
- 8) Adjusting the interlining guide position
It is necessary to adjust so that the guide (D) is positioned in the center of the slot of the sewing table and that the height is aligned with the table surface.
Loosen setscrew ① to adjust the longitudinal position and setscrew ② to adjust the height.

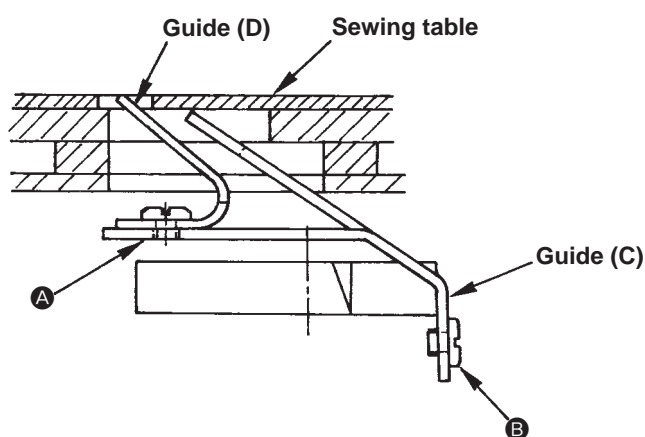

7) Single welt and double welt change unit (right) : SA111

Assembling procedure

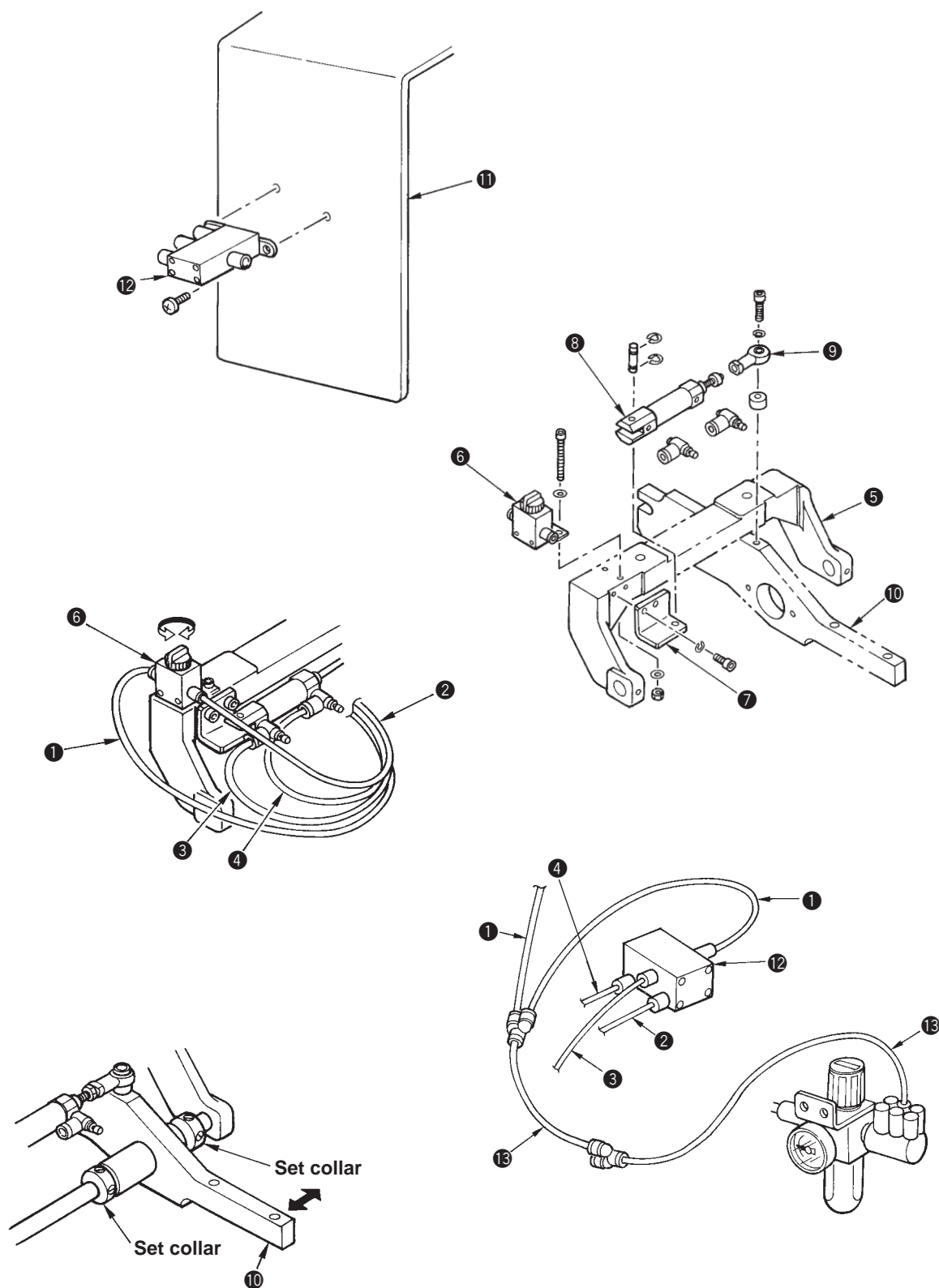

Assembling procedure	Caution when assembling
<ul style="list-style-type: none"> ○ Attach finger valve ⑥ to the fulcrum base ⑤ with the screws. ○ Attach cylinder stay ⑦ to fulcrum base ⑤ with the screws. ○ Connect cylinder stay ⑦ to air cylinder ⑧ with the pin. ○ Assemble rod end ⑨ to cylinder ⑧. ○ Attach rod end ⑨ to clamp foot arm (right) ⑩ with the screw. ○ Attach air operate valve ⑫ to solenoid valve base (1) ⑪ with the screws. <p>• Air piping</p> <ul style="list-style-type: none"> ○ Branch ø6 tube ⑬ from the regulator, and connect one of ø4 black tube ① to air operate valve ⑫ and the other to finger valve ⑥. ○ Connect ø4 pink tube ② from finger valve ⑥, ø4 blue tube ③ and ø4 transparent tube ④ from air cylinder ⑧ to air operate valve ⑫ via the rear of the clamp foot. ○ Clamp foot arm (right) ⑩ should move to the left or right (↔) by the air cylinder ⑧ when finger valve ⑥ is changed over. ○ Adjust the position of the set collar so that it is the position of the double welt when the clamp foot arm is on the left and that it is the position of the single welt when the clamp foot arm is on the right. 	

8) Clamp bar stacker : SP44

Assembling procedure

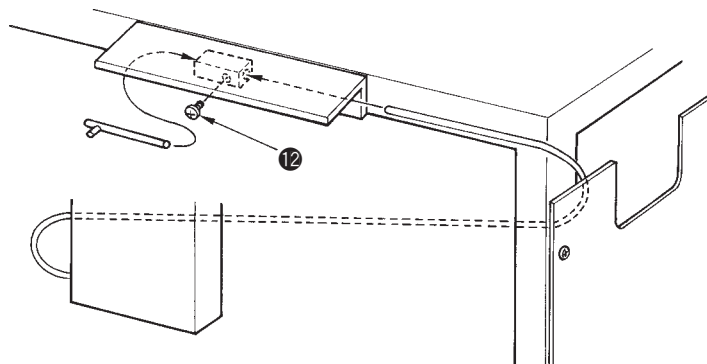
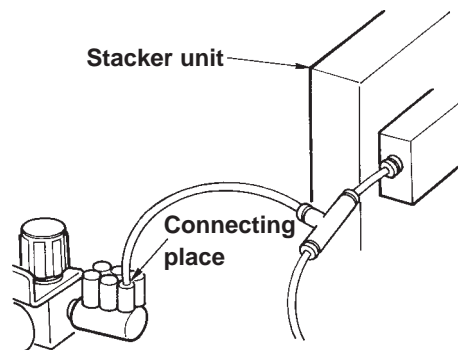
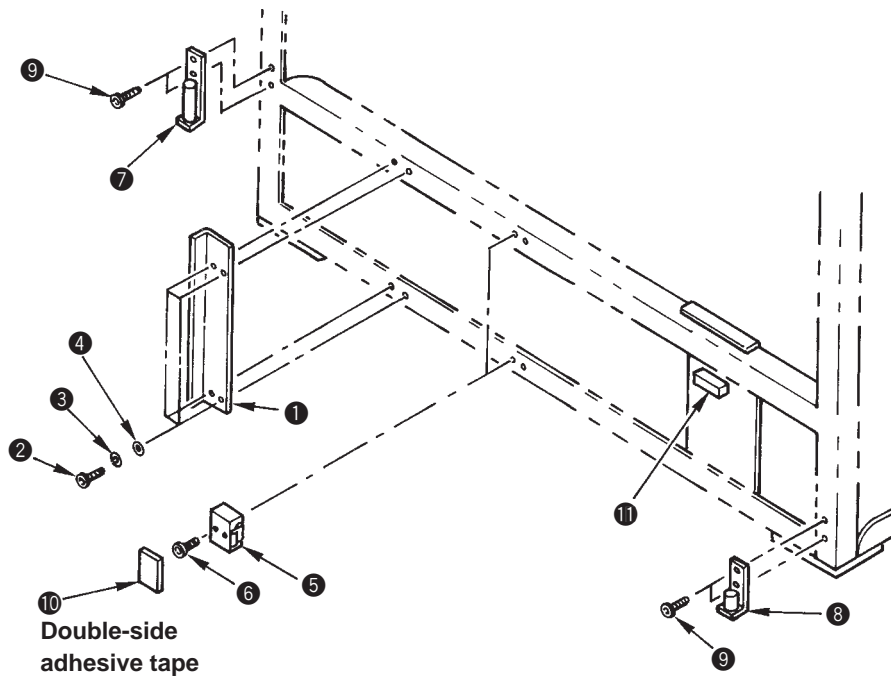

Standard Adjustment

Clamp bar stacker : SP44

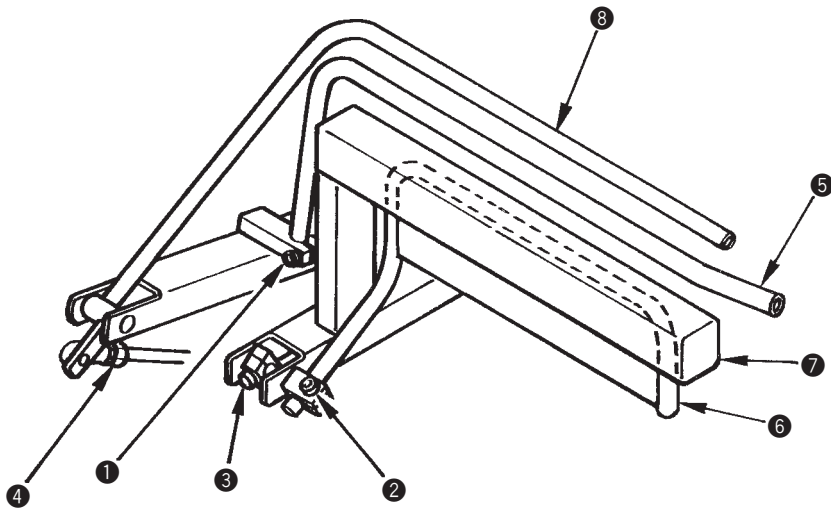

Cloth presser bars (1) ⑤ and (2) ⑥ should uniformly press cloth holder base ⑦.

In addition, the relation between cloth presser bar (1) ⑤ and that (2) ⑥ in terms of cloth holder base ⑦ should be as shown in the figure.

(Bars (1) and (2) do not interfere with each other.)

When cloth presser bar (2) ⑥ is released, it should not come in contact with left side cover ⑫.

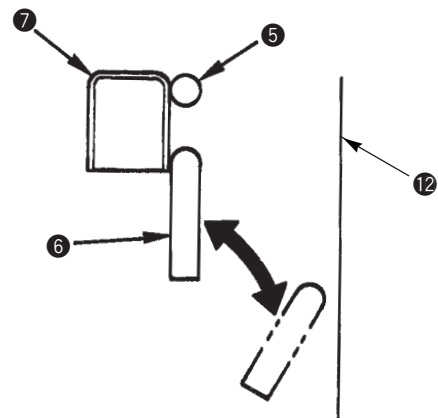

When the clamp bar stacker is in the standby state, the relation between cloth brush bar ⑧ and cloth presser bar (1) ⑤ should be as shown in the figure.

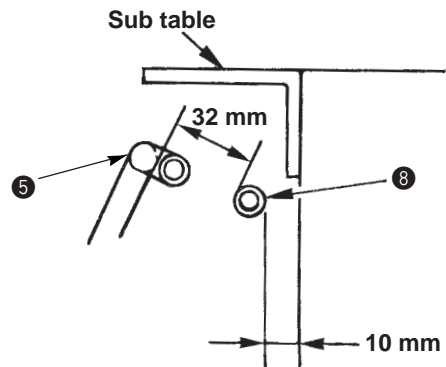

Position of the cloth placing base

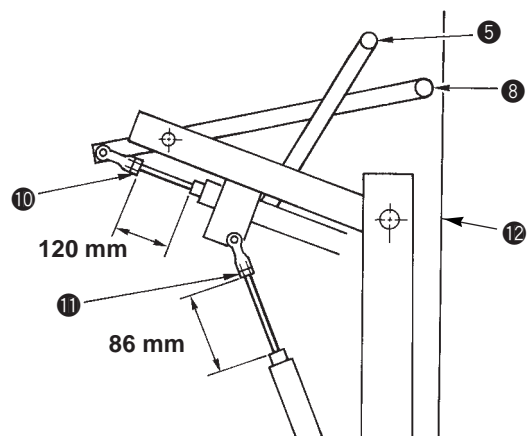
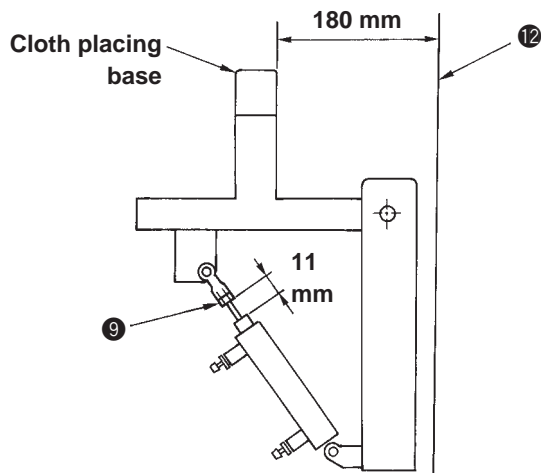



4. OPERATION PANEL

(1) Operating the operation changeover screen

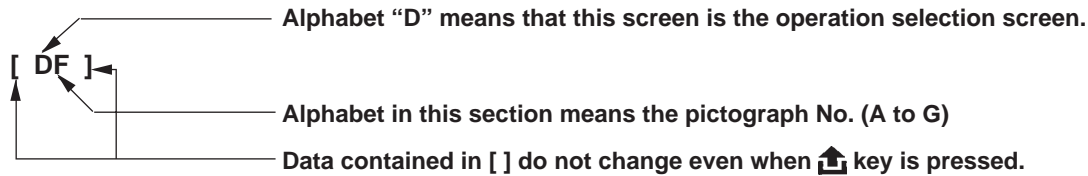
- Turn ON “2” of the DIP switch (DSW1) located on the side of the panel, and press “1” of the numeric keys, while holding pressing ∇^{123} key. Then the screen moves to the operation selection screen.
- Each operation can be changed in this screen.
- Pictograph No. is displayed above each pictograph.





<p><DA> BIND MODE 0</p>	<p>* Setting of binder self-holding operation changeover *</p> <p>: Self-holding of operation of clamp foot and binder is not performed.</p>
<p>BIND MODE 1</p>	<p>: Self-holding of operation of clamp foot and binder is performed. Press the RESET button to release this setting. Standard operation</p>
<p><DB> M-0</p> <p> M-1</p>	<p>* Setting of back tack stitching operation changeover *</p> <p>: Standard operation (The sewing machine temporarily stops at the time of back tack stitching operation.)</p> <p>: The sewing machine dose not stop and continues to sew in the back tack stitching.</p>
<p><DC> CORO MODE 0</p> <p>CORO MODE 1</p>	<p>* Setting of folding plate release at the time of corner knife operation *</p> <p>: Folding plate is closed and flap presser continues to be closed at the time of corner knife operation.</p> <p>: This setting returns the folding plate and opens the flap presser at the time of corner knife operation. Standard operation</p>
<p><DD> WELT MODE 0</p> <p>WELT MODE 1</p>	<p>* Setting of binder oscillating operation changeover *</p> <p>: Automatic welt patch feeding unit operates. Standard operation</p> <p>: Automatic welt patch feeding unit stops. (Binder does not oscillate.)</p>

<p>[DE]</p> 	<p>* Setting of starting speed at the sewing start *</p> <p>Data setting commendable value : 500 rpm (Data range : 500 to 2,500 rpm)</p> <p>← Setting data (input with the numeric keys)</p>
<p>[DF]</p> 	<p>* Setting of speed of 2nd stitch at the sewing start *</p> <p>Data setting commendable value : 700 rpm (Data range : 500 to 2,500 rpm)</p> <p>← Setting data (input with the numeric keys)</p>
<p>[DG]</p> 	<p>* Setting of speed of 3rd stitch at the sewing start *</p> <p>Data setting commendable value : 1,000 rpm (Data range : 500 to 2,500 rpm)</p> <p>← Setting data (input with the numeric keys)</p>

(2) Check program 8

Status of the batch of sensors is displayed in this screen.

- 1) Pressing adjustment data edit screen  key, press "0" of the numeric keys, and pictograph No. [CP] "CHECK PROGRAM" is displayed in the operation display section.
- 2) Press "8" of the numeric keys, then press  key to start CHECK PROGRAM mode = 8. At this time, the screen below is displayed.











CHECK PROGRAM	: ON																																																																																																																									
	: OFF																																																																																																																									
<table border="1" style="width: 100%; border-collapse: collapse; text-align: center;"> <thead> <tr> <th style="width: 10%;">*</th> <th style="width: 10%;">0</th> <th style="width: 10%;">1</th> <th style="width: 10%;">2</th> <th style="width: 10%;">3</th> <th style="width: 10%;">4</th> <th style="width: 10%;">5</th> <th style="width: 10%;">6</th> <th style="width: 10%;">7</th> <th style="width: 10%;">8</th> <th style="width: 10%;">9</th> </tr> </thead> <tbody> <tr><td>IN0 *</td><td></td><td></td><td></td><td></td><td></td><td></td><td></td><td></td><td></td><td></td></tr> <tr><td>IN1 *</td><td></td><td></td><td></td><td></td><td></td><td></td><td></td><td></td><td></td><td></td></tr> <tr><td>IN2 *</td><td></td><td></td><td></td><td></td><td></td><td></td><td></td><td></td><td></td><td></td></tr> <tr><td>IN3 *</td><td></td><td></td><td></td><td></td><td></td><td></td><td></td><td></td><td></td><td></td></tr> <tr><td>IN4 *</td><td></td><td></td><td></td><td></td><td></td><td></td><td></td><td></td><td></td><td></td></tr> <tr><td>IN5 *</td><td></td><td></td><td></td><td></td><td></td><td></td><td></td><td></td><td></td><td></td></tr> <tr><td>IN6 *</td><td></td><td></td><td></td><td></td><td></td><td></td><td></td><td></td><td></td><td></td></tr> <tr><td>IN7 *</td><td></td><td></td><td></td><td></td><td></td><td></td><td></td><td></td><td></td><td></td></tr> <tr><td>IN8 *</td><td></td><td></td><td></td><td></td><td></td><td></td><td></td><td></td><td></td><td></td></tr> <tr><td>IN9 *</td><td></td><td></td><td></td><td></td><td></td><td></td><td></td><td></td><td></td><td></td></tr> </tbody> </table>	*	0	1	2	3	4	5	6	7	8	9	IN0 *											IN1 *											IN2 *											IN3 *											IN4 *											IN5 *											IN6 *											IN7 *											IN8 *											IN9 *											
*	0	1	2	3	4	5	6	7	8	9																																																																																																																
IN0 *																																																																																																																										
IN1 *																																																																																																																										
IN2 *																																																																																																																										
IN3 *																																																																																																																										
IN4 *																																																																																																																										
IN5 *																																																																																																																										
IN6 *																																																																																																																										
IN7 *																																																																																																																										
IN8 *																																																																																																																										
IN9 *																																																																																																																										
KEY <R> = RETURN																																																																																																																										









Press "R" key to end the check program and the screen returns to the standard one.
(Caution) IN67 to 96 are for reserves.





(3) Initial setting table

The initial value of each data is as given below when the power is turned ON.



1) <Sewing pattern screen>

<p><AA></p> 	<p>* Operation mode changeover * : Cloth feed mode (at this time, tension disk is closed.)</p>
<p><AB></p> 	<p>* Sewing mode changeover * : L-size sewing</p>
<p><AC></p> 	<p>* Sewing reference changeover * : Rear-reference sewing (The sewing end position is spaced 320 mm away from the needle bar.)</p>
<p><AD></p> 	<p>* Changeover of operation/stop of the automatic flap feeding unit * : Setting of the automatic flap feeding unit operation</p>
<p><AE></p> 	<p>* Changeover of operation/stop of the stacker operation * : Setting of the stacker operation</p>
<p><AF></p> 	<p>* Changeover of the welt patch cutting device operation * : Setting of the welt patch cutting device operation</p>
<p>[AG]</p> 	<p>* Flap jump speed setting * : Flap jump speed (unit : mm/s)</p>
<p><AH></p> 	<p>* Setting of flap concealed stitching data * : Flap concealed stitching data for the sewing start of left-hand side seam (seam is produced outside the flap.)</p>
<p><AI></p> 	<p>* Setting of flap concealed stitching data * : Flap concealed stitching data for the sewing end of left-hand side seam (seam is produced outside the flap.)</p>
<p>[AL]</p> 	<p>* Setting of flap forced stop data * : Flap forced stop</p>





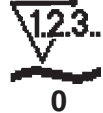





<p>[AM]</p> 	<p>* Corner knife selection * : Corner knife selection</p>
<p><AN></p> 	<p>* Setting of difference at the sewing start * : Difference at the sewing start (The right-hand side seam is shorter than the left-hand side one.) * The pictograph appears on the display only for APW-298. For the APW-297, it will not appear on the display.</p>
<p><AO></p> 	<p>* Setting of difference at the sewing end * : Difference at the sewing end (The left-hand side seam is shorter than the right-hand side one.) * The pictograph appears on the display only for APW-298. For the APW-297, it will not appear on the display.</p>
<p>[AP]</p> 	<p>* Setting of the center knife actuating position at the sewing start * : Center knife actuating position at the sewing start</p>
<p>[AQ]</p> 	<p>* Setting of the center knife actuating position at the sewing end * : Center knife actuating position at the sewing end</p>
<p><AR></p> 	<p>* Setting of the corner knife actuating position at the sewing start * : Corner knife actuating position at the sewing start (The knife retracts.)</p>
<p><AS></p> 	<p>* Corner knife actuating position at the sewing end * : Corner knife actuating position at the sewing end (The knife retracts.)</p>
<p>[AT]</p> 	<p>* Lockstitch pitch setting * : Lockstitch pitch</p>
<p><AU></p> 	<p>* Setting of condensation stitching and back tack stitching at the sewing start * : Setting of condensation stitching and condensation pitch at the sewing start</p>









<p>[AV]</p>  <p>3</p>	<p>* Setting of the number of back tack stitches at the sewing start * : Setting of the number of back tack stitches at the sewing start</p>
<p><AW></p>  <p>1.0</p>	<p>* Setting of condensation stitching and back tack stitching at the sewing end * : Setting of condensation stitching and condensation pitch at the sewing end</p>
<p>[AX]</p>  <p>3</p>	<p>* Setting of the number of back tack stitches at the sewing end * : Setting of the number of back tack stitches at the sewing end</p>
<p><AY></p> <p>DartS SEWING ON</p>	<p>* Dart stretcher operation changeover * : Dart stretcher is set to operative.</p>
<p><AZ></p> <p>Vacuum SEWING ON</p>	<p>* Vacuum operation changeover * : Vacuum is set to operative.</p>
<p><Aa></p> 	<p>* Changing over the operation of the automatic interlining cloth feeder * : Automatic interlining cloth feeder is set to operative.</p>

2) <Counter screen>





<p>[BA]</p>  <p>0</p>	<p>* Total counter *</p>
<p>[BB]</p>  <p>0</p>	<p>* No. of pcs. counter *</p>
<p>[BC]</p>  <p>0</p>	<p>* Bobbin thread counter *</p>
<p><BD></p>  <p>ON 0</p>	<p>* Setting of the actuation of the bobbin thread remaining amount detecting device and the bobbin thread remaining amount adjusting counter *</p>

3) <Adjustment data edit screen>

 <p><CA> 3 JUKI</p>	<p>* Changeover of the clamp foot position after completion of sewing * : Back end stopping mode</p>
 <p><CB> Dart's OPTION ON</p>	<p>* Changeover of operation/stop of optional dart stretcher* : Dart stretcher operates.</p>
 <p><CC> Vacuum OPTION ON</p>	<p>* Changeover of operation/stop of optional vacuum * : Vacuum operates.</p>
 <p><Ca> SPEED</p>	<p>* Setting of the speed of the automatic interlining cloth feeder * : Low speed * The pictograph appears on the display only when the automatic interlining cloth feeder is mounted.</p>
 <p>[Cb] 15</p>	<p>* Excess length of interlining cloth to be fed by the automatic interlining cloth feeder (at the start of sewing) * * The pictograph appears on the display only when the automatic interlining cloth feeder is mounted.</p>
 <p>[Cc] 15</p>	<p>* Excess length of interlining cloth to be fed by the automatic interlining cloth feeder (at the end of sewing) * * The pictograph appears on the display only when the automatic interlining cloth feeder is mounted.</p>
 <p><CD> 0</p>	<p>* Welt patch sensor detecting time * : Stop</p>
 <p><CE> 0</p>	<p>* Setting of thread trimming timing * : Timer of the thread trimmer (standard timing)</p>
 <p>[CF] 0.10</p>	<p>* Setting of the stacker timer 1 * : Stacker timer 1 (unit : second)</p>
 <p>[CG] 1.50</p>	<p>* Setting of the stacker timer 2 * : Stacker timer 2 (unit : second)</p>
 <p>[CH] 60</p>	<p>* Setting of needle throwing ratio for the normal feed section * : Needle throwing ratio for the normal feed section (The needle throws in direction same as that of the feed.)</p>

<p>[CI]</p> 	<p>* Setting of needle throwing ratio for the back tack stitching at the sewing start *</p> <p>: Needle throwing ratio for the back tack stitching at the sewing start (The needle rocks in the opposite direction of the feed.)</p>
<p>[CJ]</p> 	<p>* Setting of needle throwing ratio for the back tack stitching at the sewing end *</p> <p>: Needle throwing ratio for the back tack stitching at the sewing end (The needle throws in direction same as that of the feed.)</p>
<p>[CK]</p> 	<p>* Setting of sewing speed under the high-speed mode *</p> <p>: Number of revolutions for lockstitching</p>
<p>[CL]</p> 	<p>* Setting of sewing speed under the low-speed mode *</p> <p>: Setting of the sewing speed for condensation stitching or backtacking</p>
<p><CM></p> 	<p>* Setting of the sewing machine independent operation mode *</p> <p>: The sewing machine independent operation mode starts up using the DIP switches. : No operation</p>
<p>[CN]</p> 	<p>* Setting of ON time of the intermittent operation of the sewing machine under the independent sewing mode *</p>
<p>[CO]</p> 	<p>* Setting of OFF time of the intermittent operation of the sewing machine under the independent sewing mode *</p>
<p>[CP]</p> <p>Check P.G.M. MODE 0</p>	<p>* Check program mode selection *</p>
<p><CR></p> 	<p>* Front reference position changeover *</p> <p>: Front reference position is spaced 140 mm away from the needle position.</p>
<p><CS></p> 	<p>* Display mode changeover *</p> <p>: Cycle mode</p>

4) <Operation selection screen>

<p><DA> BIND MODE 1</p>	<p>* Setting of binder self-holding operation changeover * : Standard operation</p>
<p><DB>  M-0</p>	<p>* Setting of back tack stitching operation changeover * : Standard operation</p>
<p><DC> CORO MODE 1</p>	<p>* Setting of folding plate release when the corner knife actuates. * : Standard operation</p>
<p><DD> WELT MODE 0</p>	<p>* Setting of binder oscillating operation changeover * : Standard operation</p>
<p>[DE]  start1 500</p>	<p>* Setting of starting speed at the sewing start * : Data setting commendable value : 500 rpm</p>
<p>[DF]  start2 700</p>	<p>* Setting of speed of 2nd stitch at the sewing start * : Data setting commendable value : 700 rpm</p>
<p>[DG]  start3 1000</p>	<p>* Setting of speed of 3rd stitch at the sewing start * : Data setting commendable value :1,000 rpm</p>

(4) Setting of DIP switches located in the rear of the panel

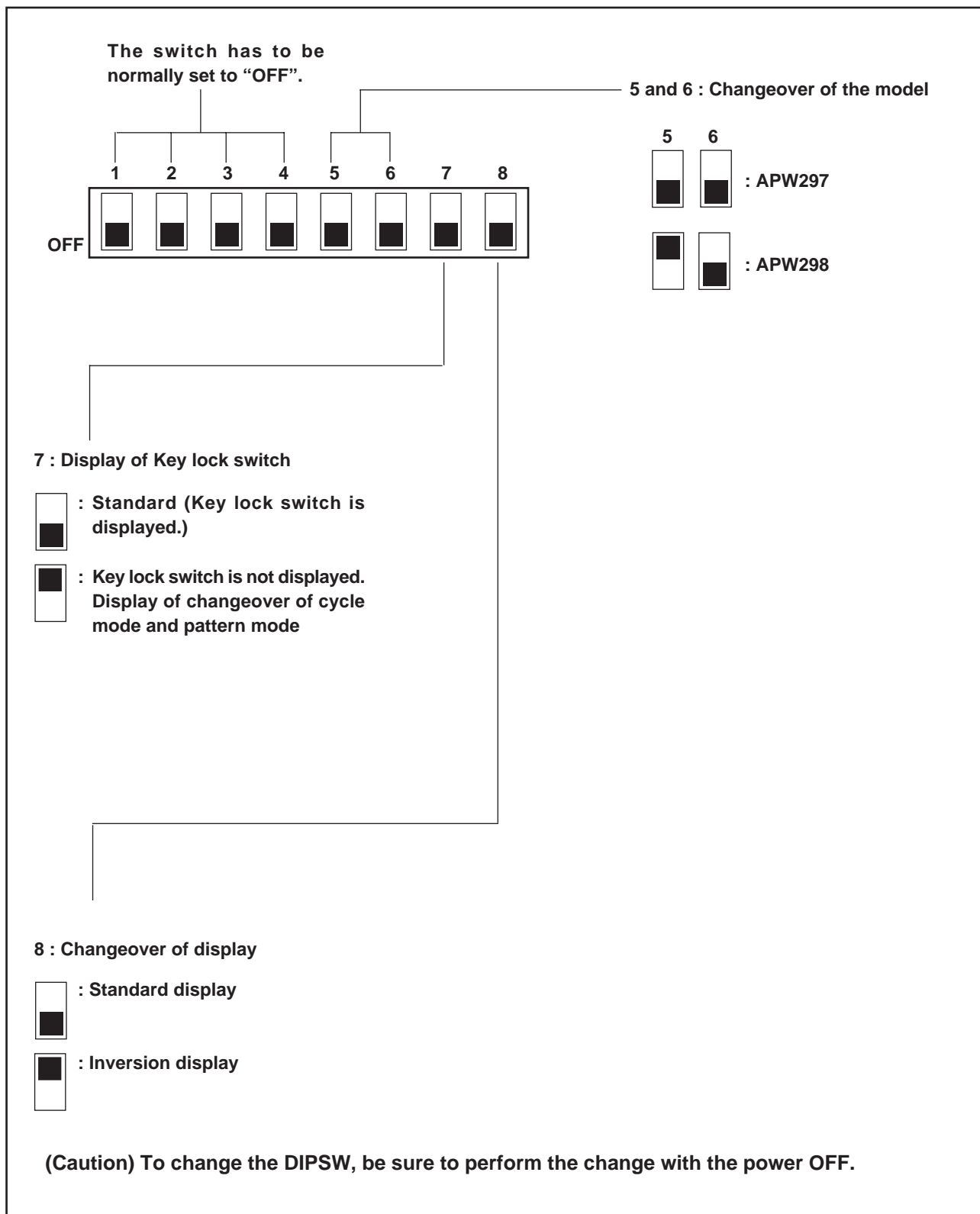

5. PARTS TO WHICH GREASE OR LOCKTITE IS APPLIED

Main shaft and thread take-up lever components

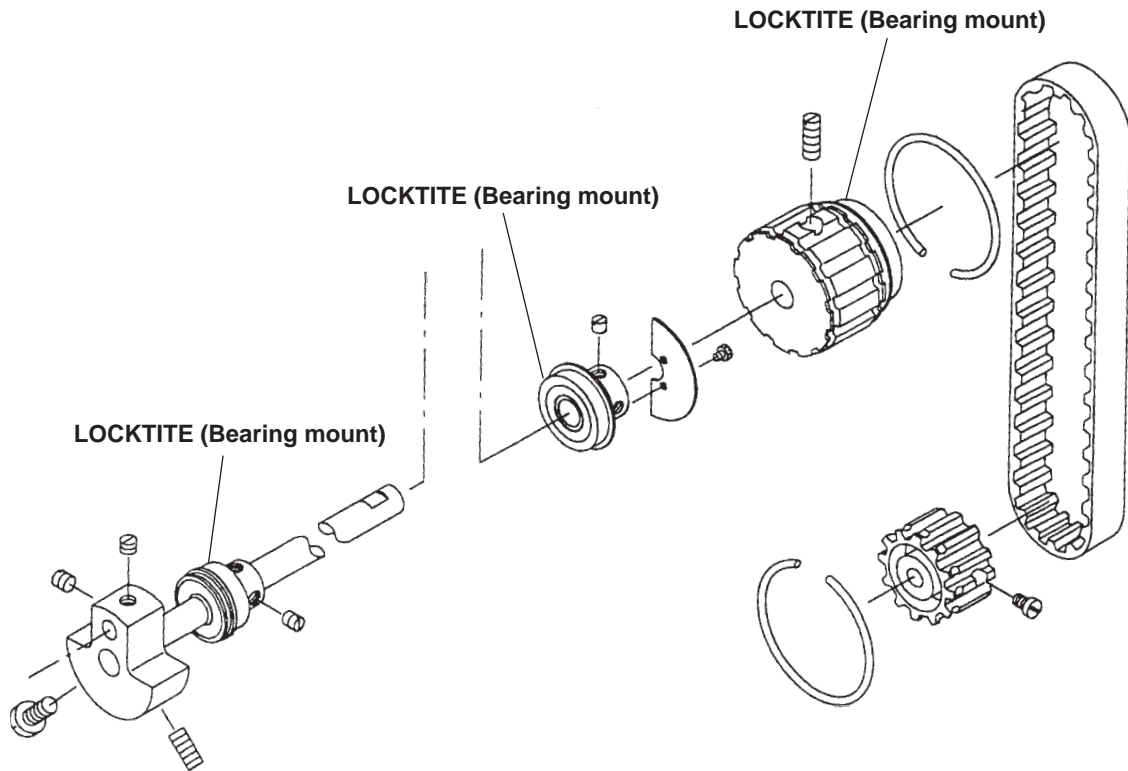

Needle bar frame components

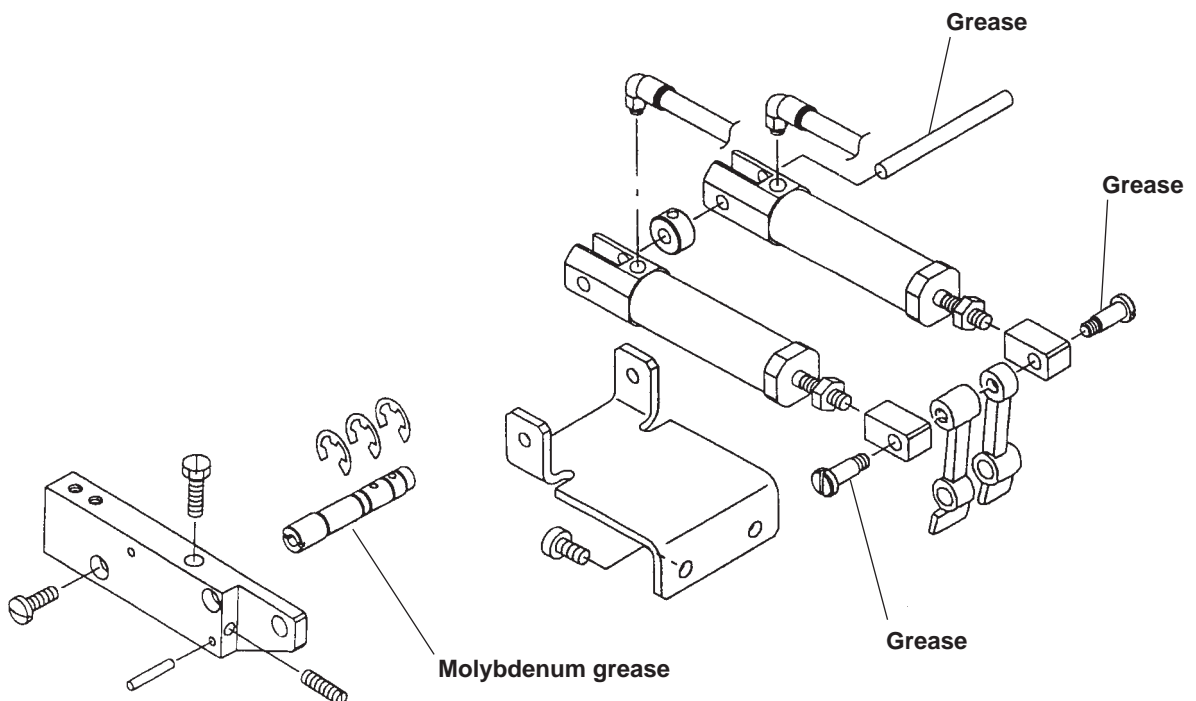

Needle feed components

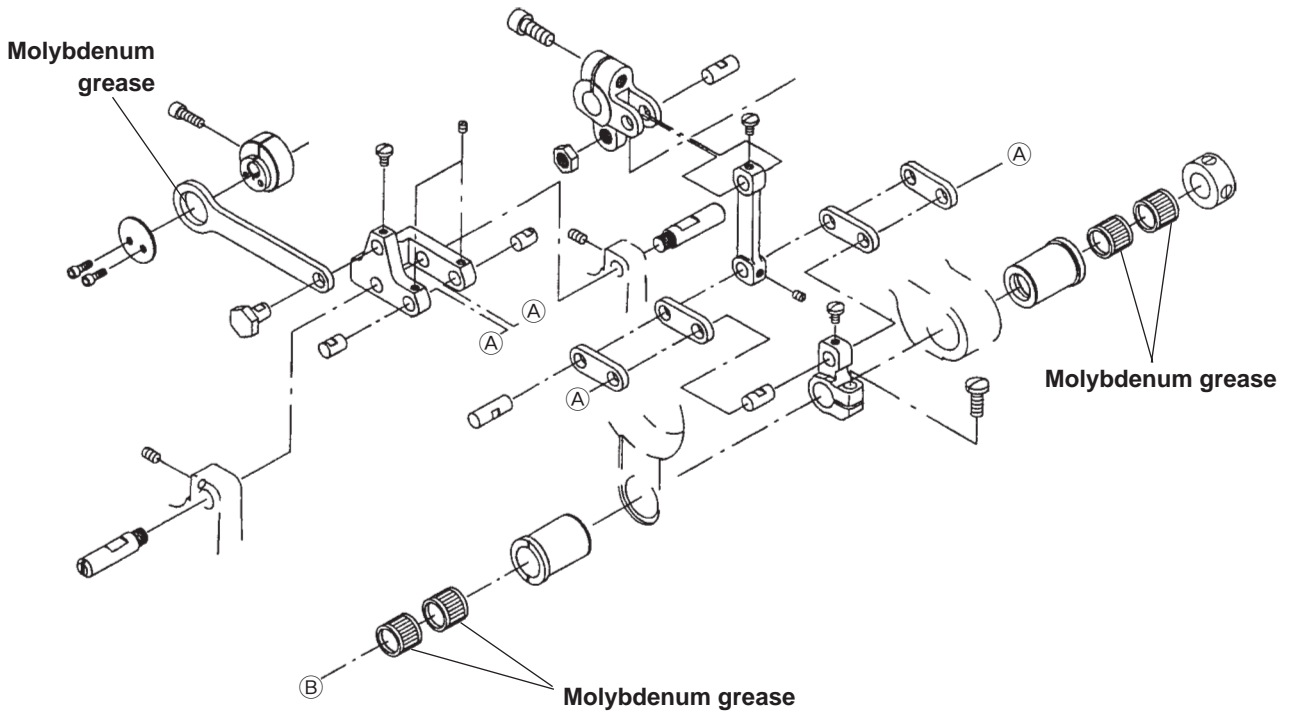

Bobbin thread trimmer components

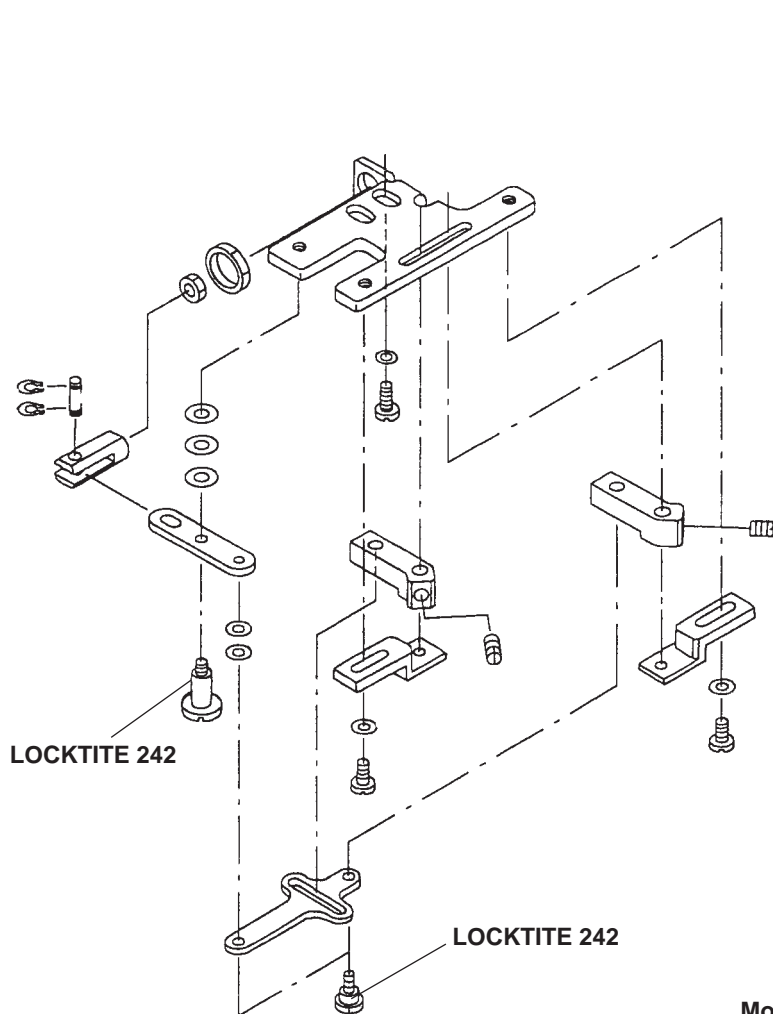

Needle thread trimmer components

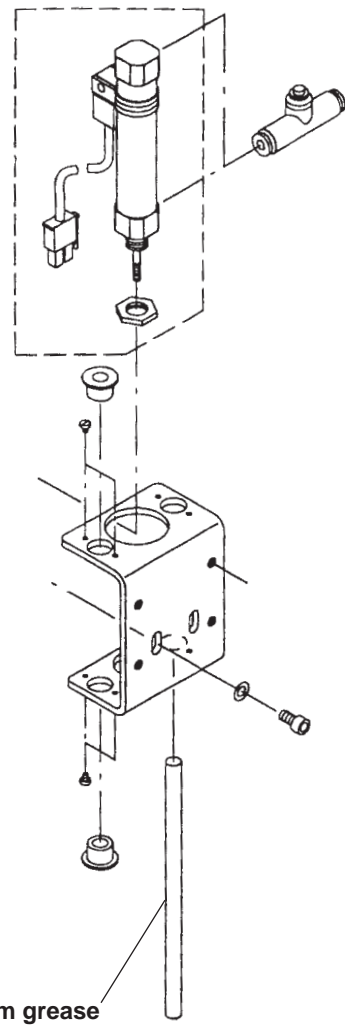

Upper knife components

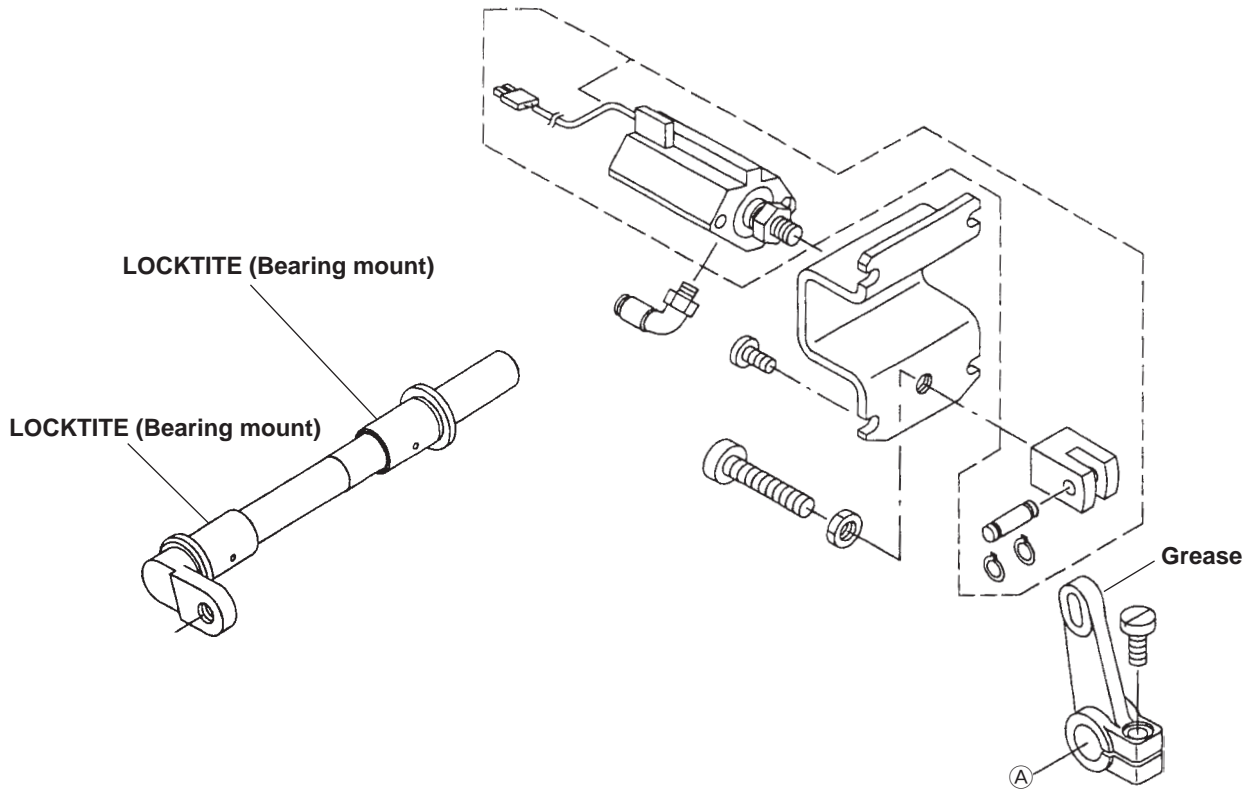

Pedal switch components

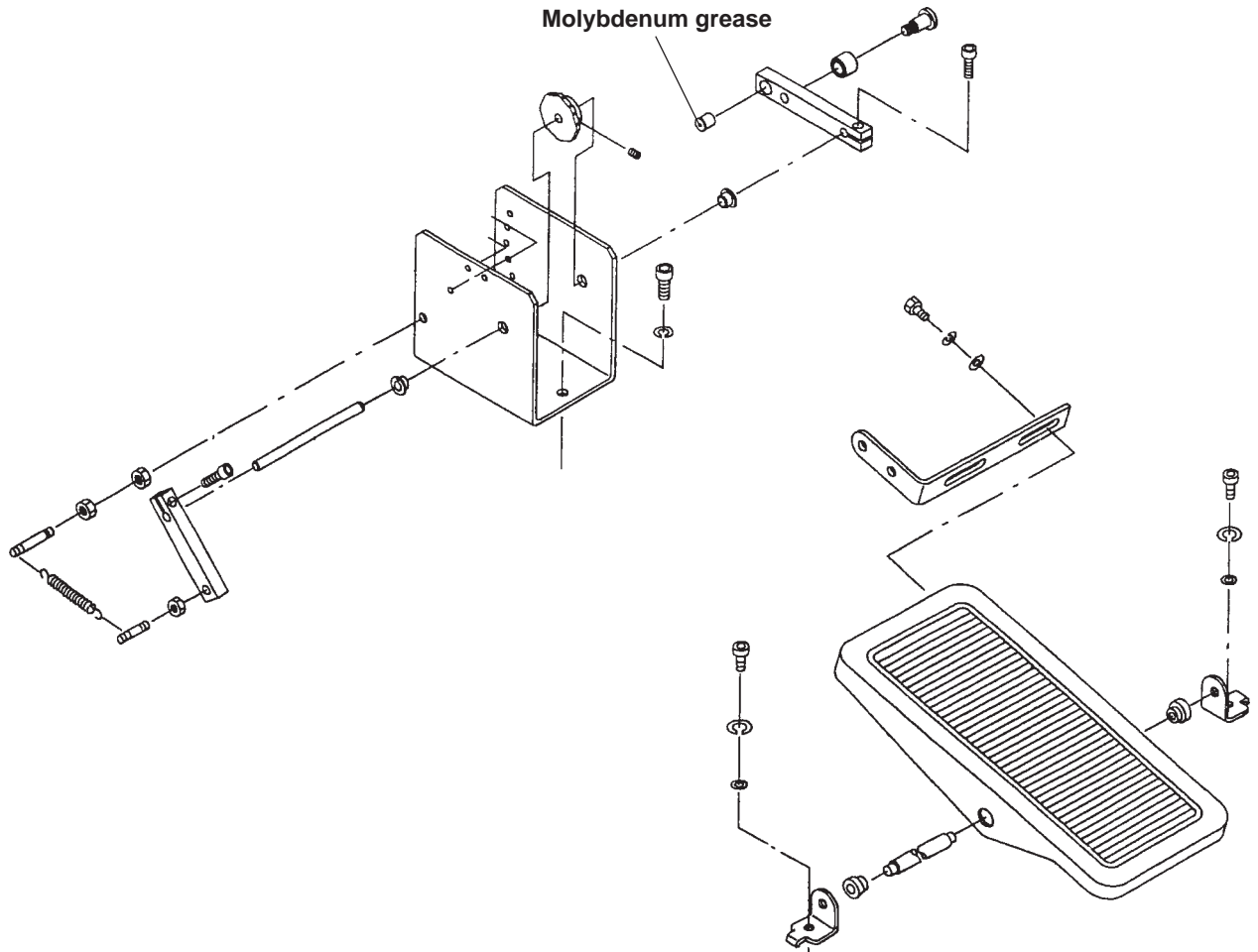

Clamp foot (left side) components (2)

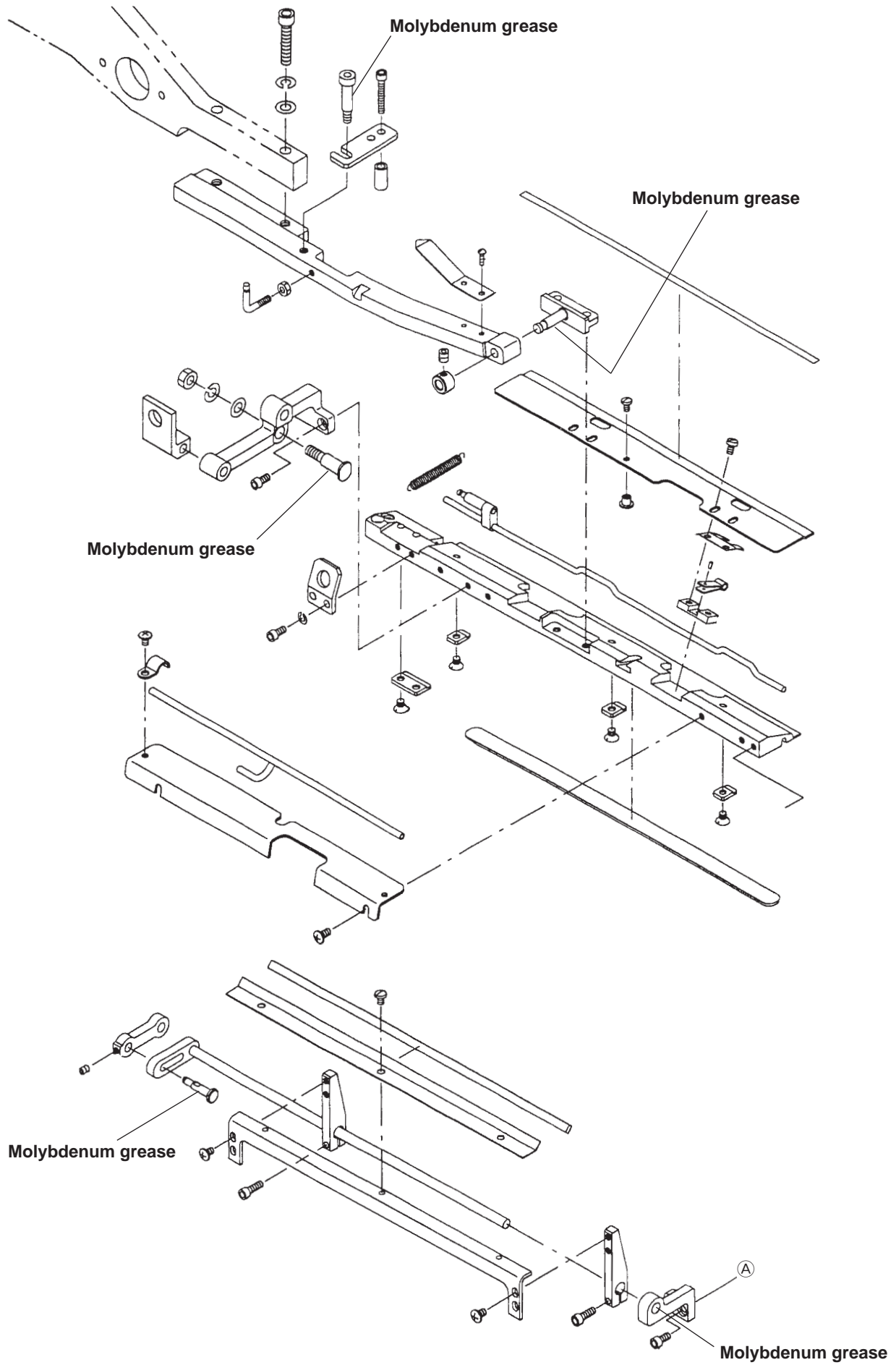

Clamp foot (right side) components (3)

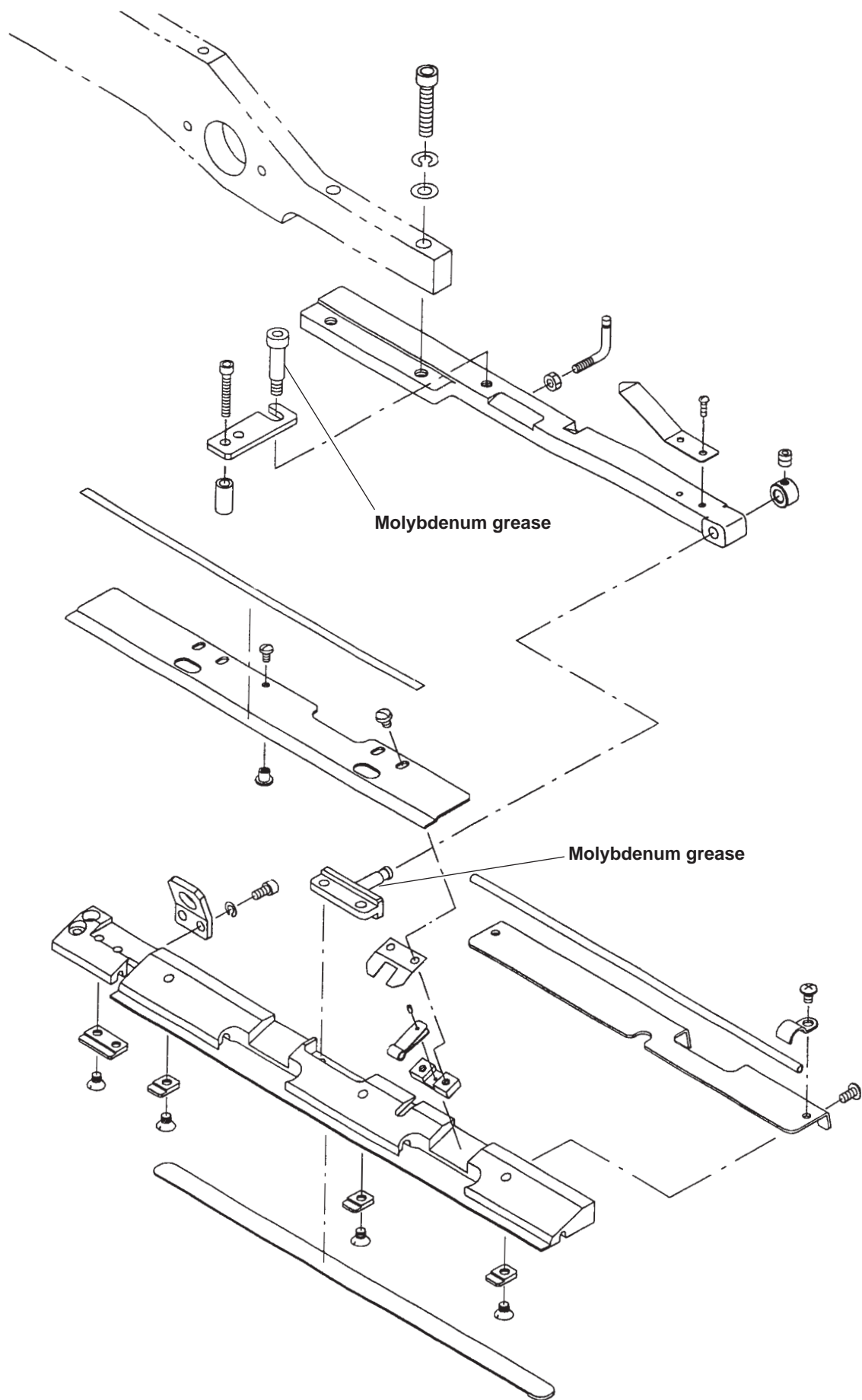

Clamp foot feed components

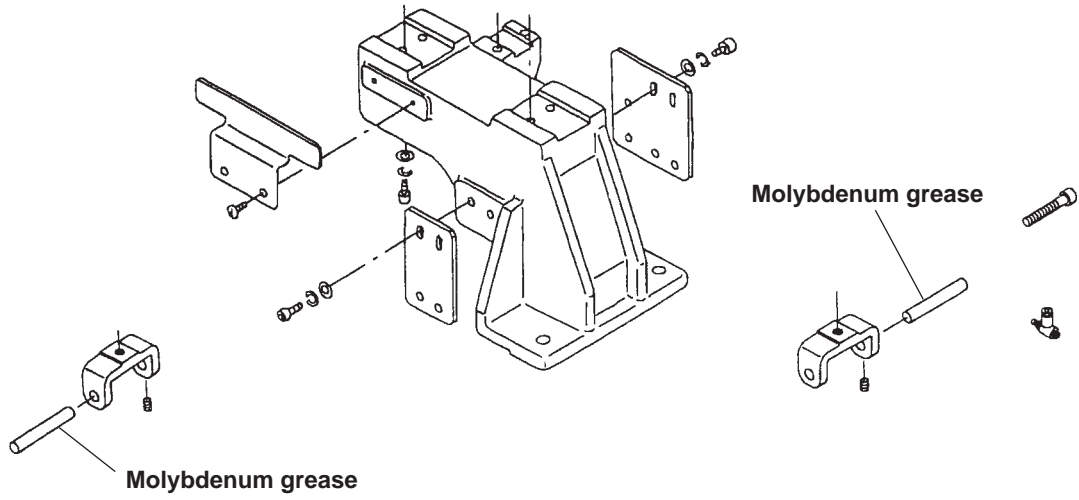

Corner knife components (1)

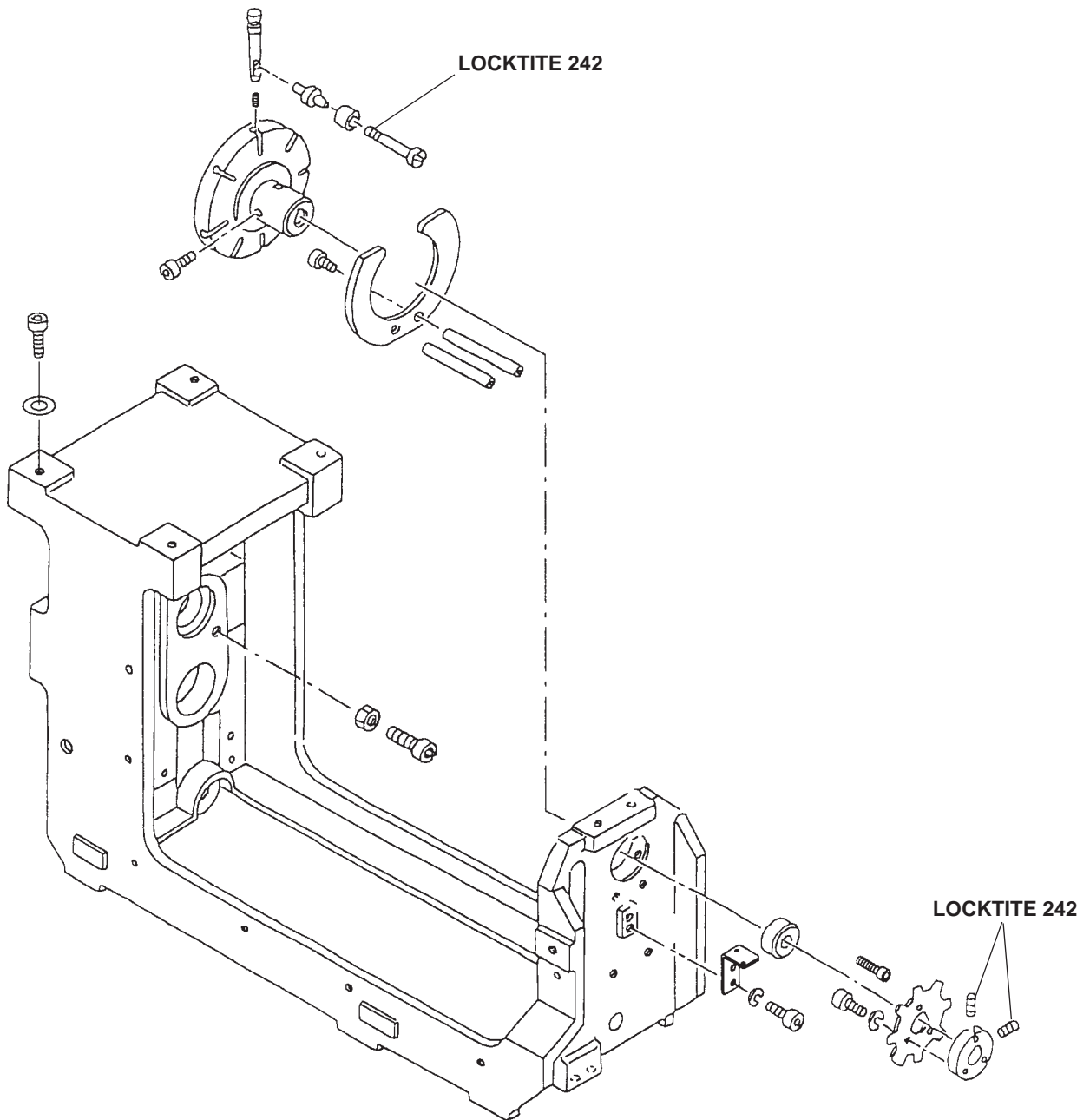

Corner knife components (2)

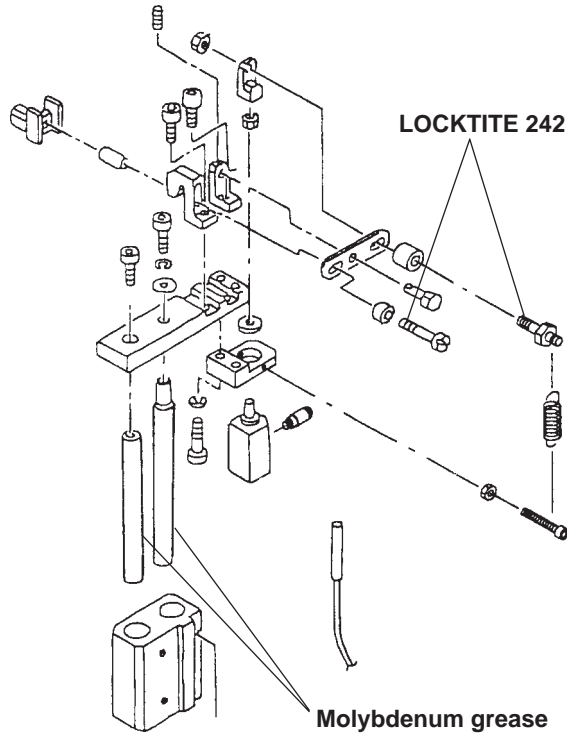

Corner knife components (4)

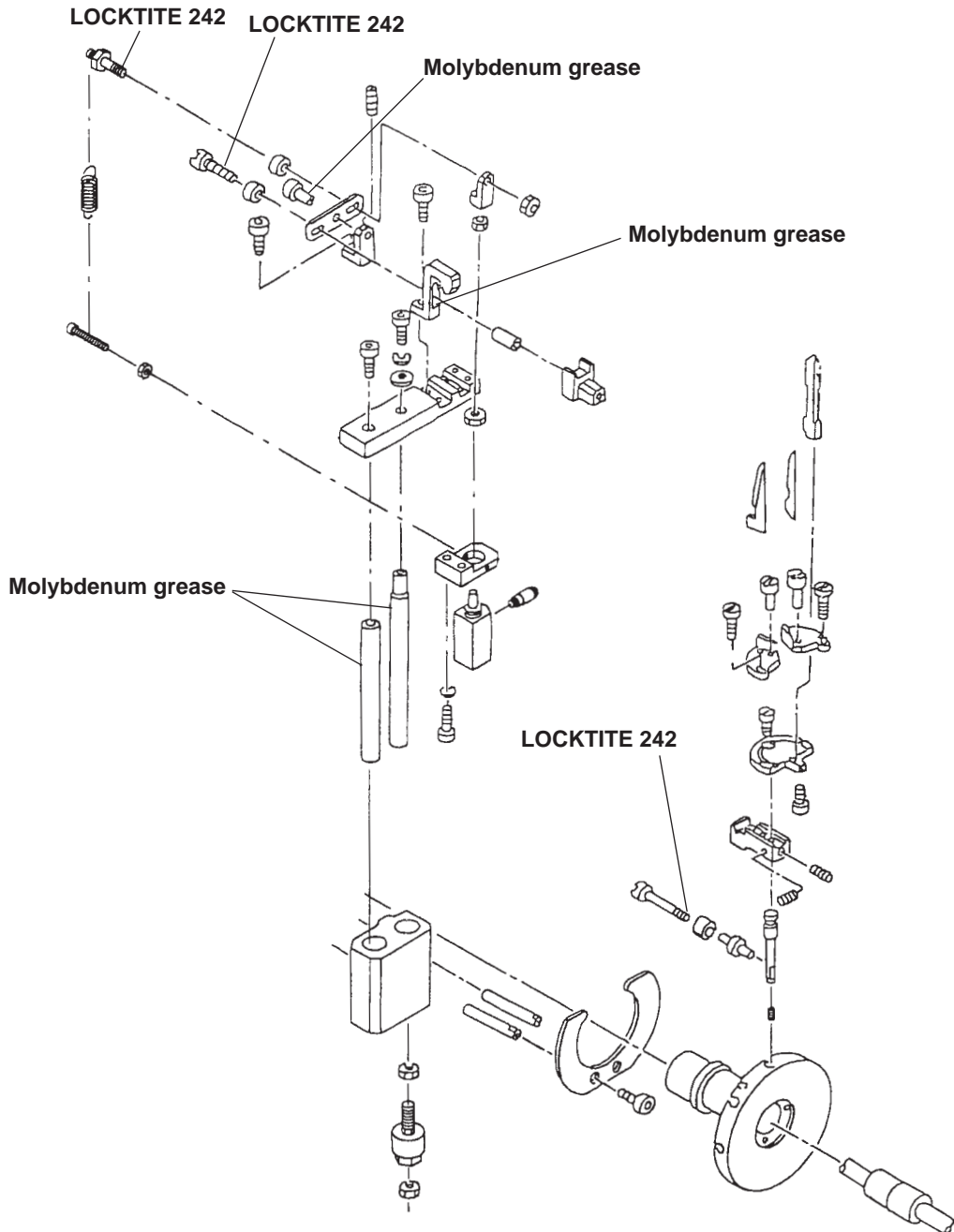

Binder components (1)

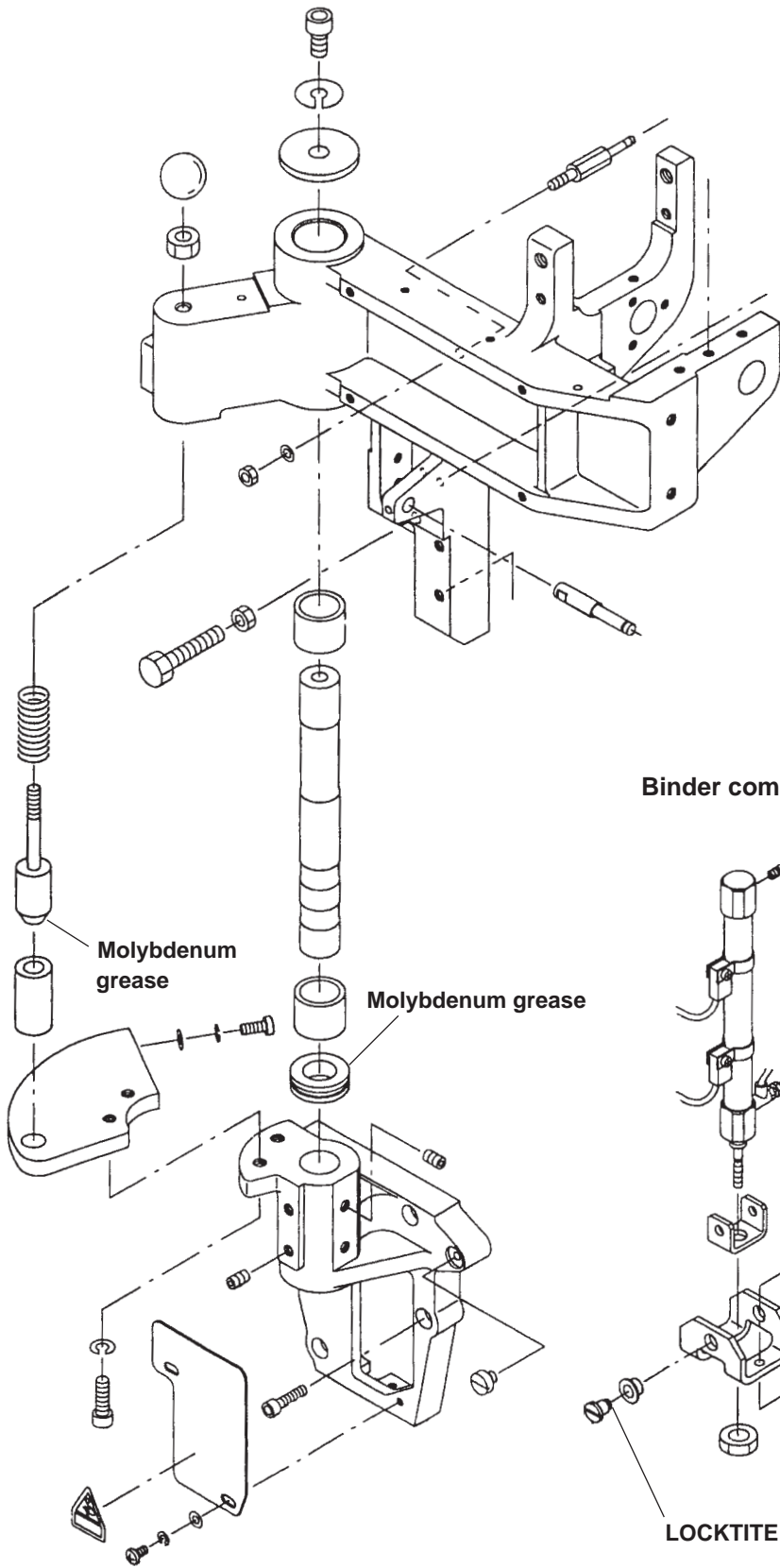

Binder components (2)

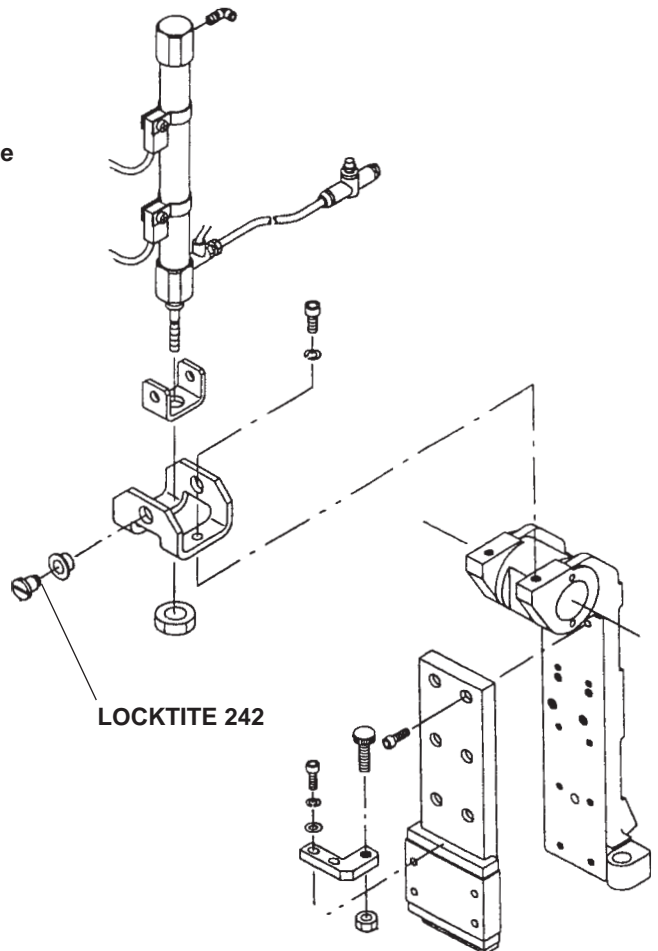

Front binder components

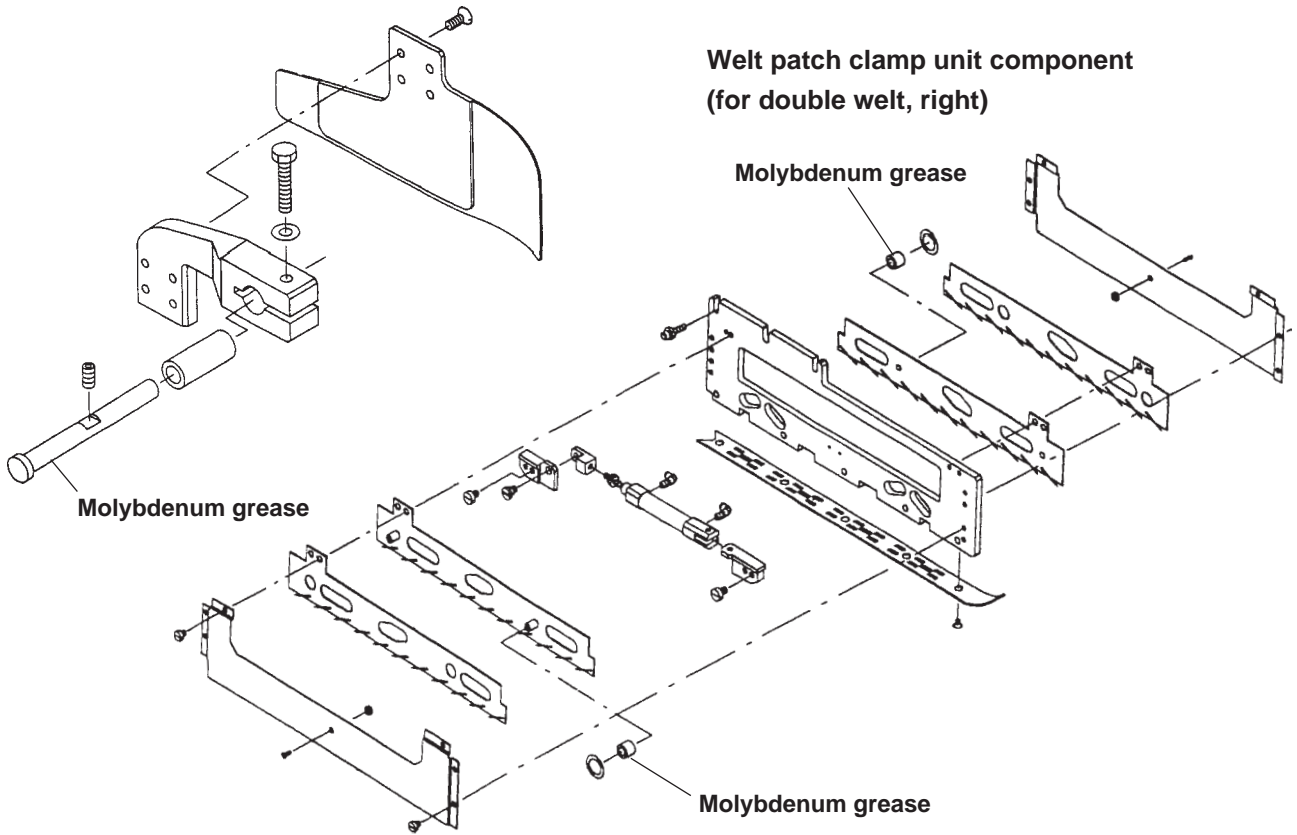

Automatic flap supply unit (left) (1)

(Optional)

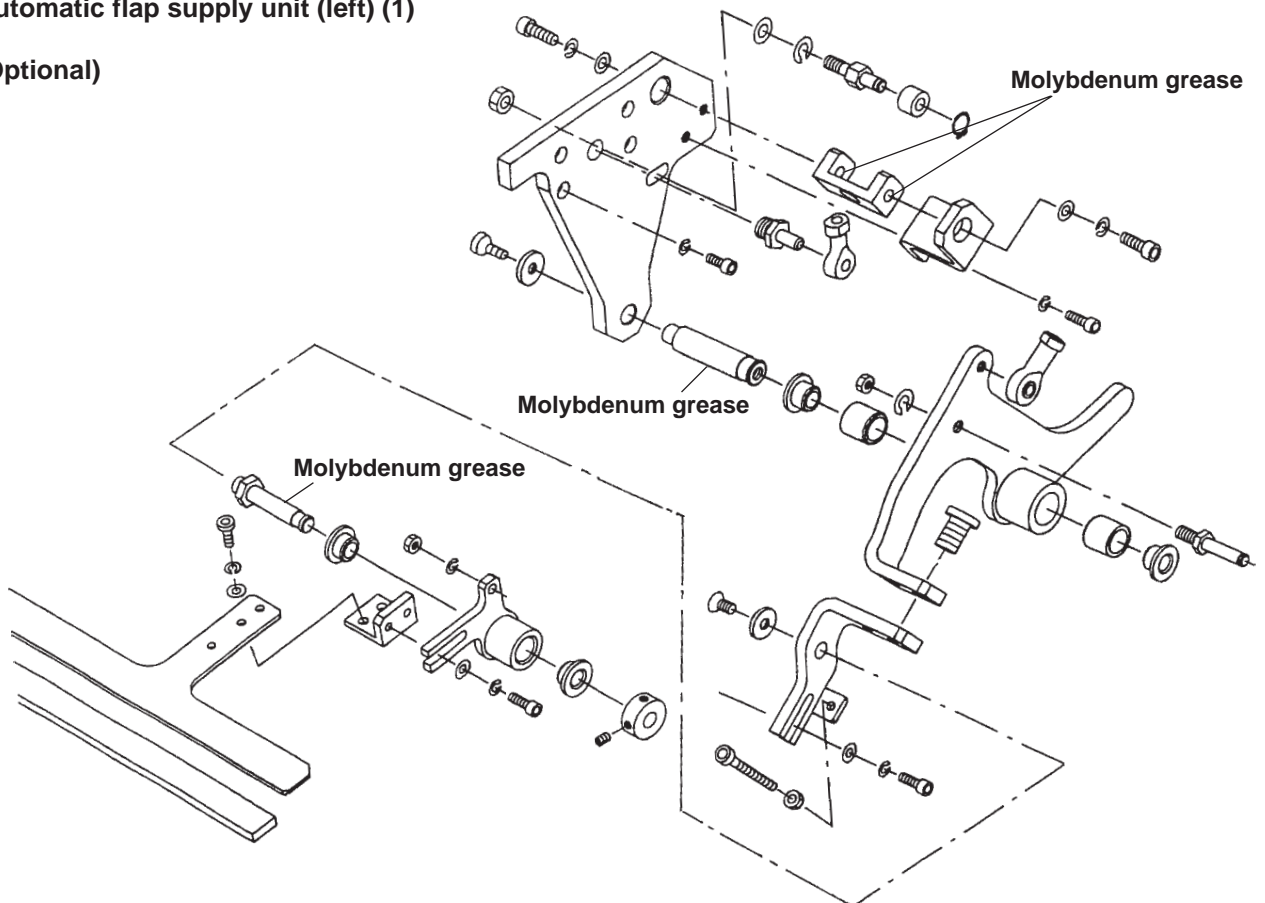

Welt patch cut unit (right) (1) (Optional)

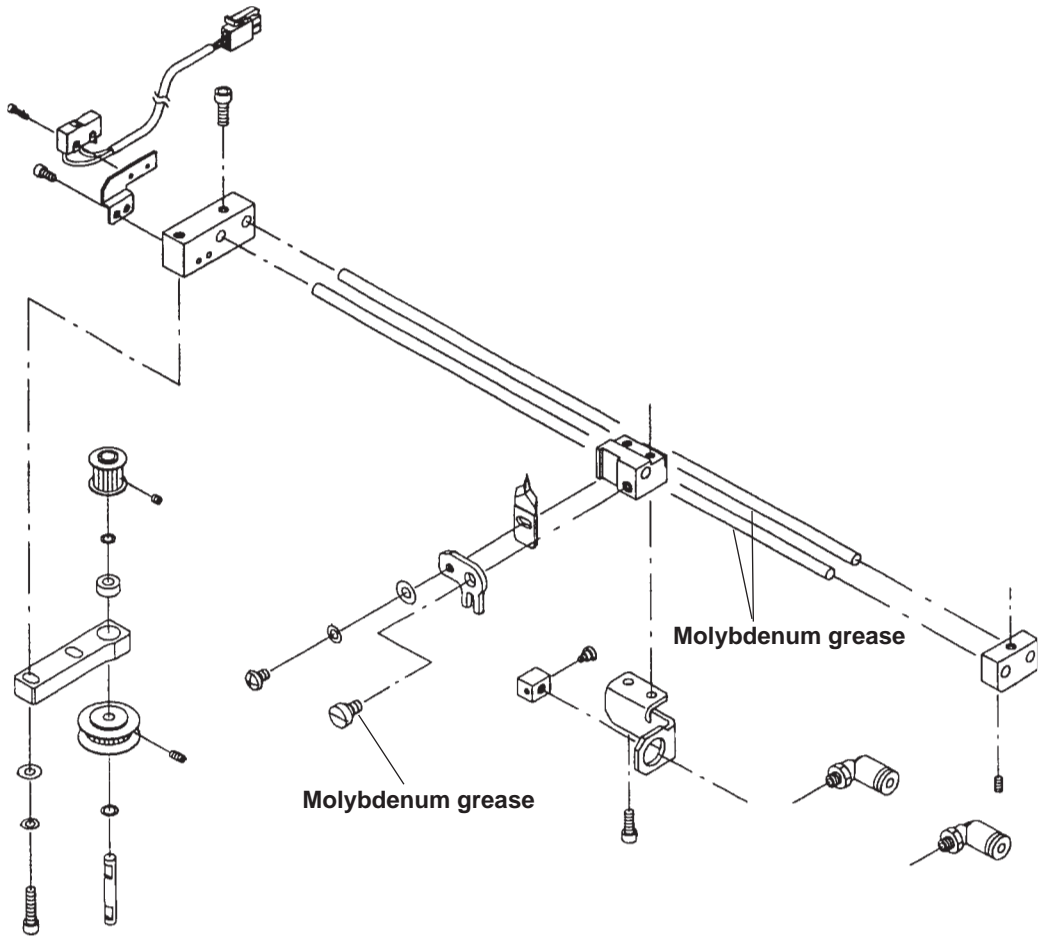

Welt patch cut unit (right) (2) (Optional)

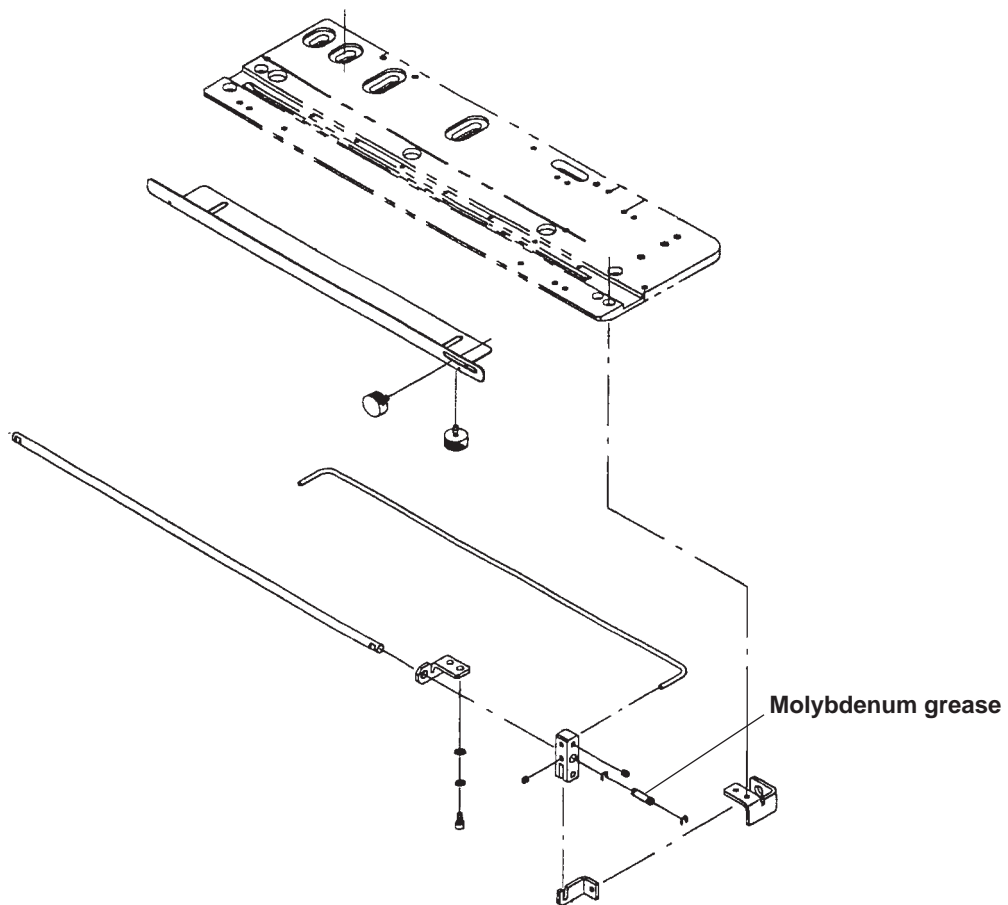

Bag cloth simultaneous supply unit (left) (Optional)

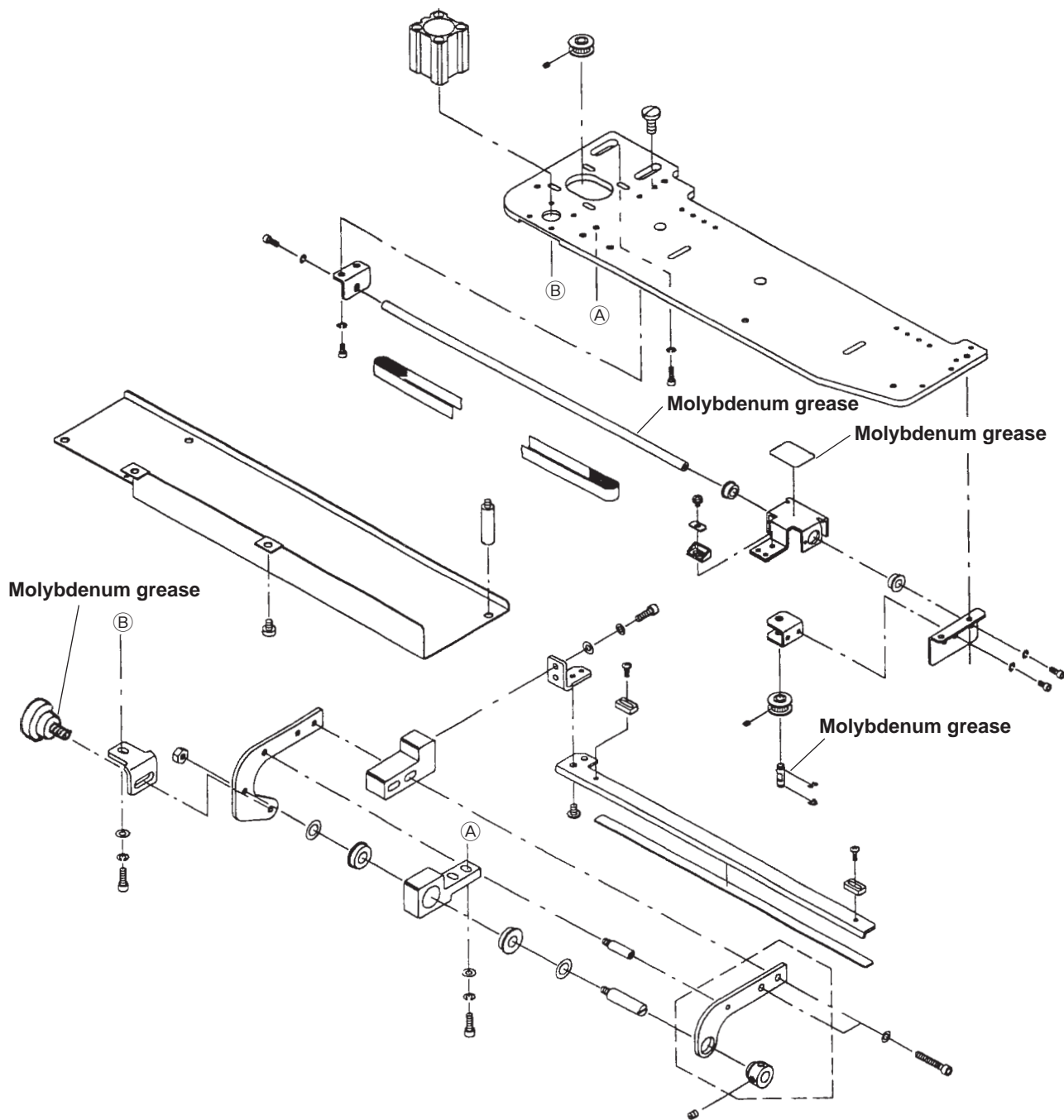

A blank sheet of lined paper with rounded corners and horizontal ruling lines. The page is oriented vertically and contains 20 horizontal lines spaced evenly down the page. The top and bottom corners are rounded.

6. AIR CIRCUIT DIAGRAM (APW-297, -298)

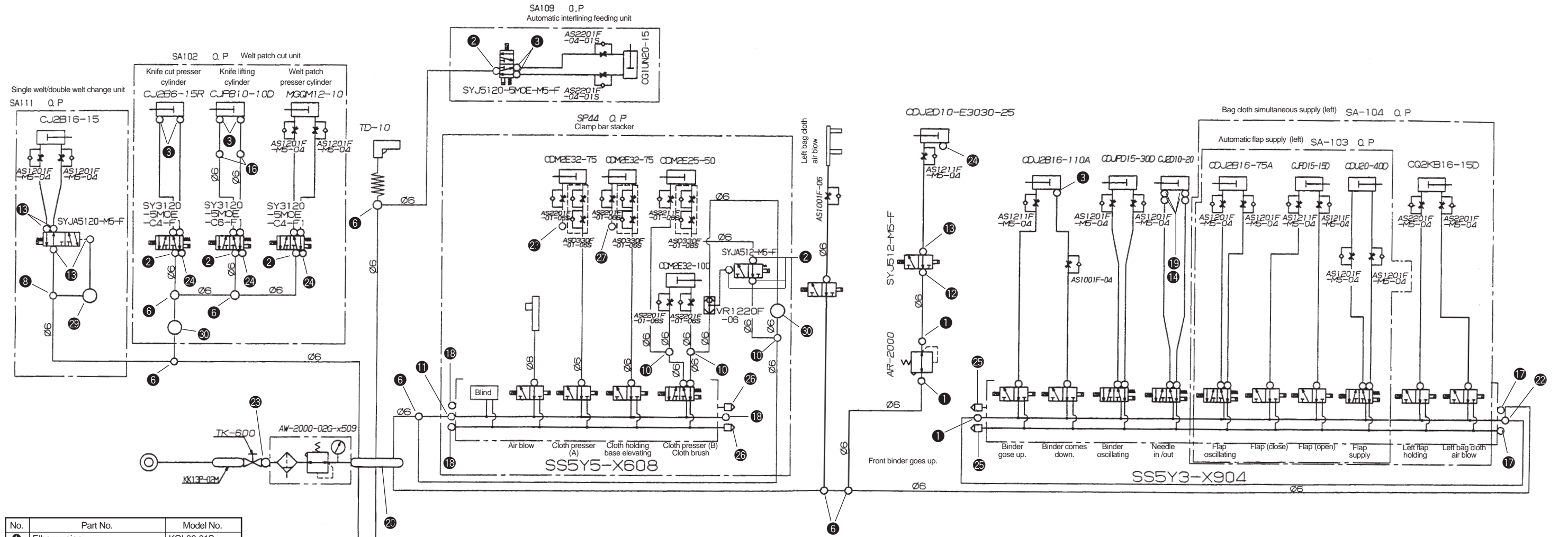

No.	Part No.	Model No.
1	Elbow union	KQL06-01S
2	Elbow union	KQL06-M5
3	Elbow union	KQL04-M5
4	Elbow union	KQL04-01S
5	Different diameter straight	KQH06-04
6	Y union	KQU06-00
7	Y union	KQU04-00
8	Different diameter Y union	KQU04-06
9	T joint	KQT04-00
10	T joint	KQT06-00
11	Half union	KQH06-02S
12	Half union	KJS06-M5
13	Half union	KJS04-M5
14	Half union	KQH04-M5
15	Half union	IN-298-10
16	Different diameter straight	KQH04-06
17	Blind tap	1/8"
18	Blind tap	1/4"
19	Universal elbow	M-5UL
20	Triple universal elbow	KQZT06-02S
21	Branch elbow union	KQLU06-01S
22	Branch universal elbow	KQZ06-01S
23	Nipple	1/4"
24	Silencer	AN120-M5
25	Silencer	AN103-01
26	Silencer	AN203-02
27	Silencer	AN103-KM6
28	Finger valve	VHK3-04F-04FL
29	Finger valve	VHK3-04F-04F
30	Finger valve	VHK3-06F-06F-L
31	Different diameter straight	KQH04-06
32	Pipe elbow	M-5HL-4
33	Hose nipple	M-5H-4

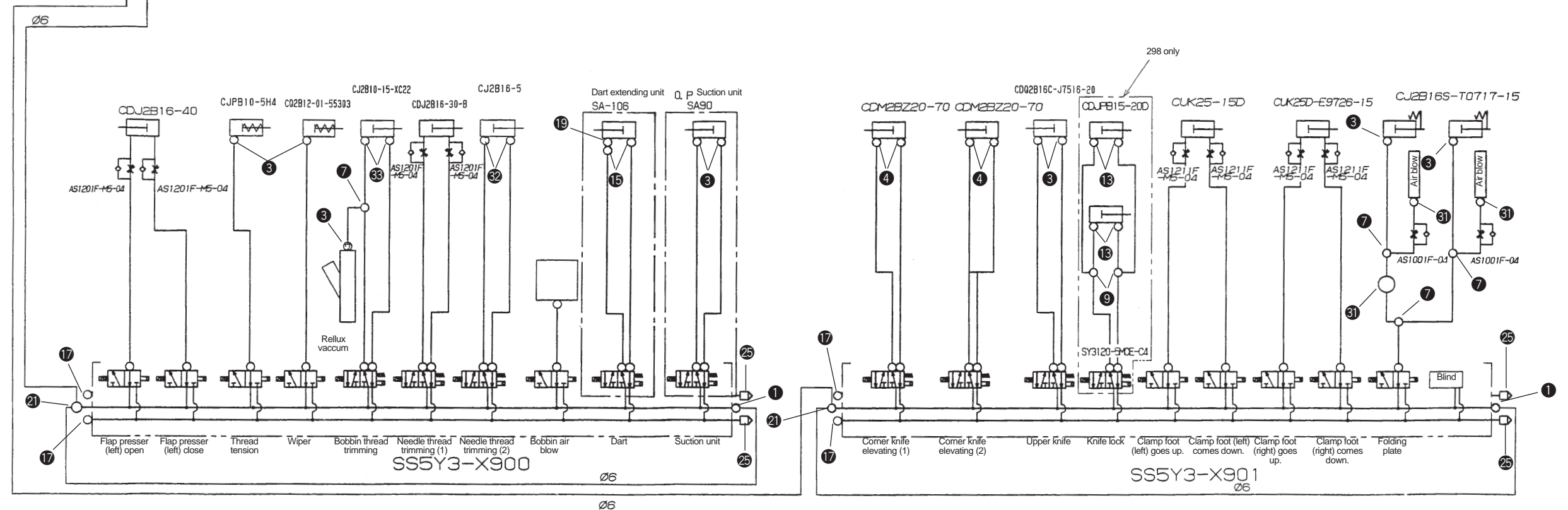

(Caution) The diameter of air hose without indication is to be $\phi 4$.

7. ELECTRICAL CONTROL BOX

(1) Explanation of components

1) Arrangement in the control box

This diagram describes the components arranged inside the control box such as the circuit board, transformer, etc.

As for the cables, those whose both ends are connected inside the box are described and others whose ends are taken to the outside of the box are omitted.

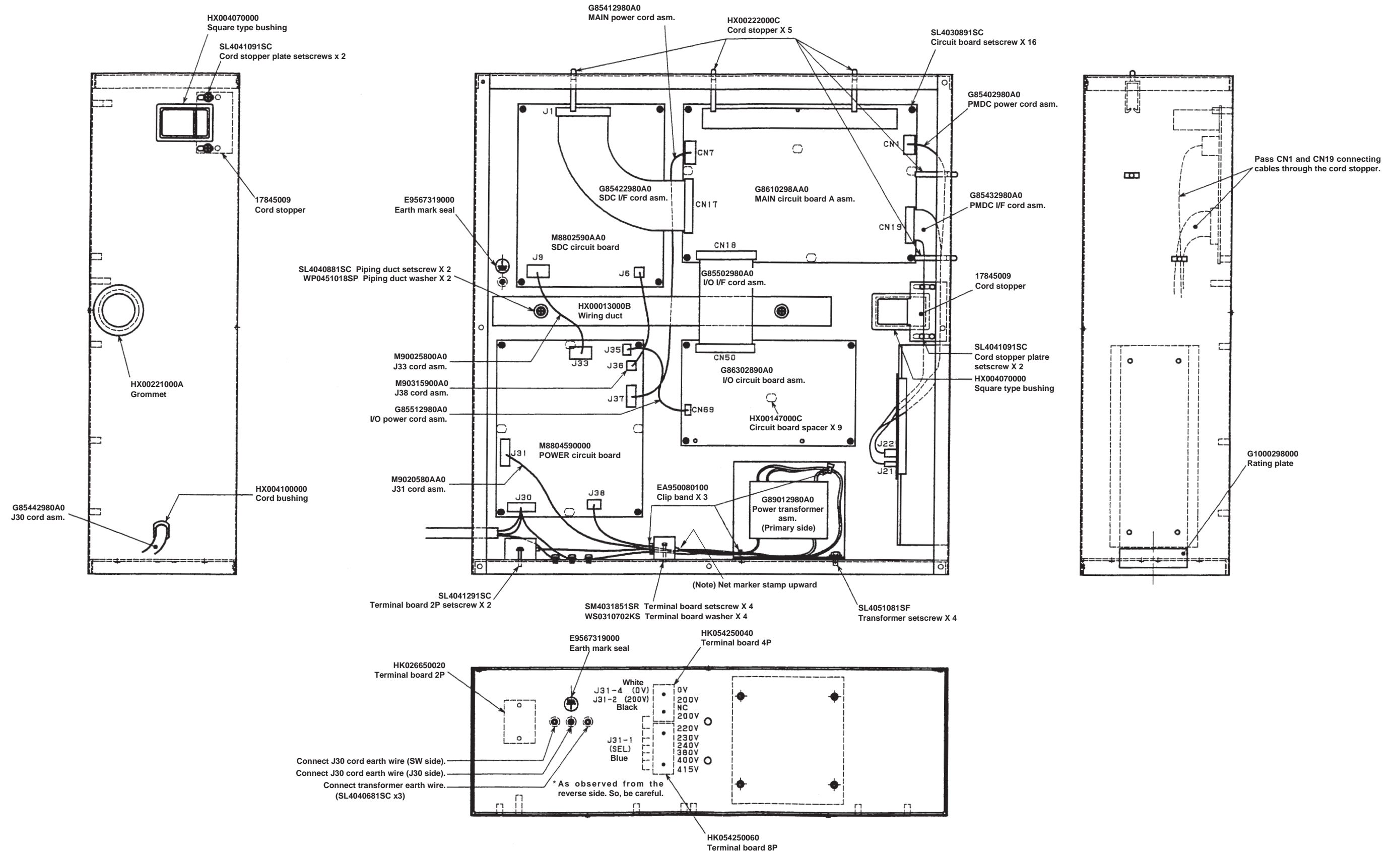

2) Function and setting place of each circuit board

This machine contains the respective circuit boards in two places; one is in the control box located on the right bottom side of the table (inside of the side cover) and the other in the operation panel box.

Main functions and setting places of the respective circuit boards are as given below.

Five sets of the circuit boards are set inside the control box.

However, for PMDC circuit board asm. only, the circuit board for APW-297 is different from that for APW-298.

Control box

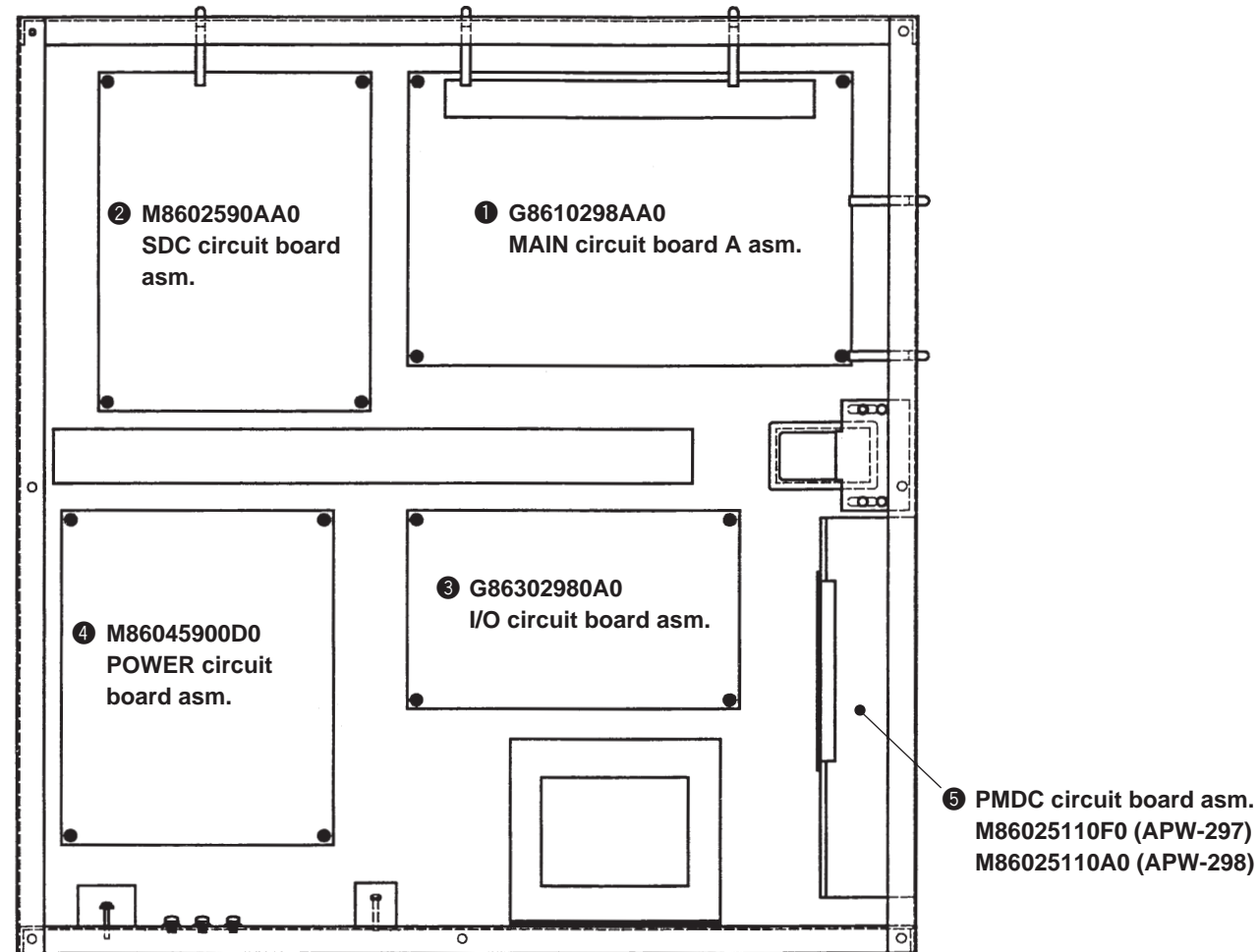

- ① MAIN circuit board A asm. : This is the circuit board which performs main control of this machine.
- ② SDC circuit board asm. : This circuit board performs the control of main shaft servo motor of the machine head.
- ③ I/O circuit board asm. : This circuit board performs input/output of sensor, solenoid valve, stepping motor, etc.
- ④ POWER circuit board : This circuit board mainly provides control power voltage.
- ⑤ PMDC circuit board asm. : This circuit board performs travel of the corner knife and control of the stepping motor for selection.

(Caution) The EPROMs (2 places) mounted with the part No. of the aforementioned MAIN circuit board A asm. are raw ROMs. The ROM after writing is required.

For the details, refer to the item "Replacing the EPROM" on page 113.

Two sets of the circuit boards are set in the operation panel box.

Operation panel box

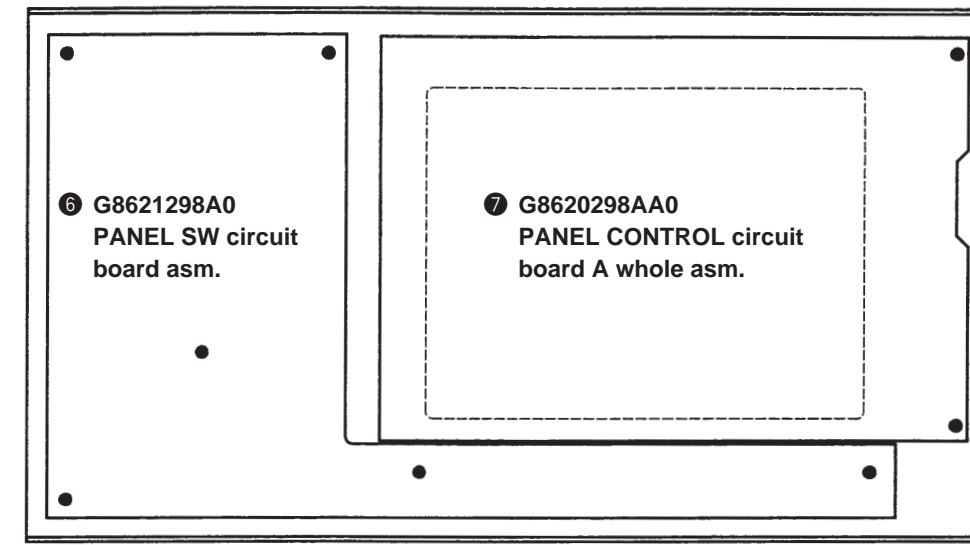

- ⑥ PANEL SW circuit board asm. : This circuit board performs the input of each switch and DIP switch on the panel.
- ⑦ PANEL CONTROL circuit board A asm. : This circuit board performs enclosing of display control data of the operation panel.

(Caution) The EPROM (one place) mounted with the part No. of the aforementioned PANEL CONTROL circuit board A asm. is a raw ROM. The ROM after writing is required.

For the details, refer to the item "Replacing the EPROM" on page 113.

(2) Replacing the components

1) Replacing the fuse

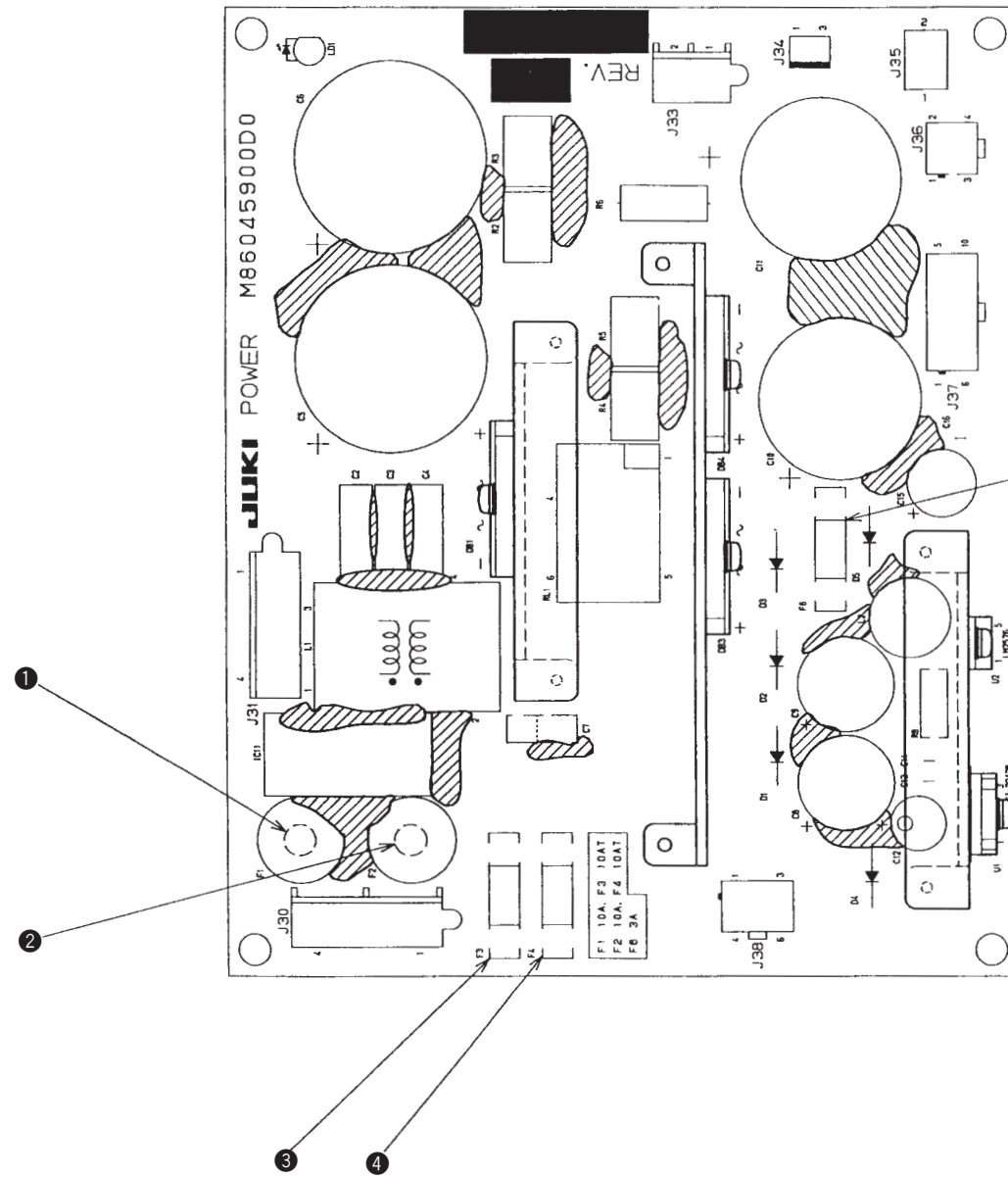

- ❶ F1 fuse 10A
For AC200 to 415V protection
Fuse for main power line protection
- ❷ F2 fuse 10A
For AC200 to 415V protection
Fuse for main power line protection
- ❸ F3 fuse 10AT
Fuse for DC+35V and +24V protection
For the power of stepping motor, solenoid valve, sensor, etc. protection
- ❹ F4 fuse 10AT
Fuse for DC+24VA protection
For the power of servo motor for clamp foot travel protection
- ❺ F6 fuse 3A
Fuse for DC+5V protection
For the power for control circuit drive protection

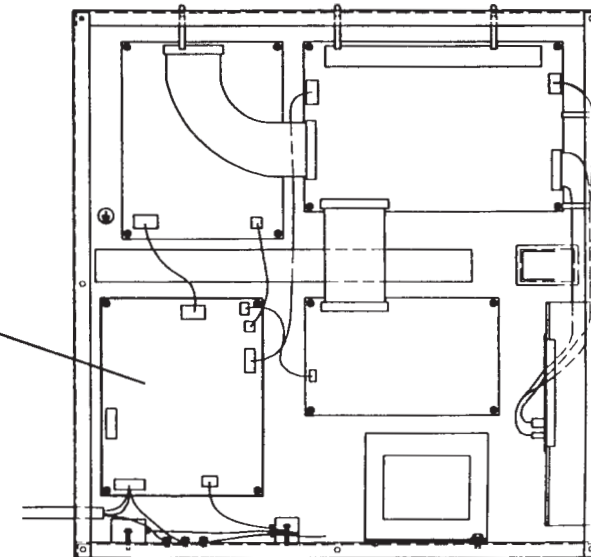

2) Replacing the EPROM

There are four mounting places of EPROM in total for this machine.
Mount the designated EPROMs in the respective designated places.

	Mounting ROM	APW-298	APW-297	Contents of main control	Name of circuit board
A	U18-27C1024 (40 Pin)	HL015930049	HL015930049	For main operation control	MAIN circuit board
B	U5-27C1001 (32 Pin)	HL010520221	HL010520221	For clamp foot servo motor control	
C	U15-27C4096 (40 Pin)	HL015310021	HL015310021	For operation panel control	PANEL-CTL circuit board
D	U8-27C256 (28 Pin)	HL008423064	HL008423064	For DD servo motor control	SDC circuit board

There are two places, **A** and **B** where the EPROMs are mounted in the MAIN circuit board.

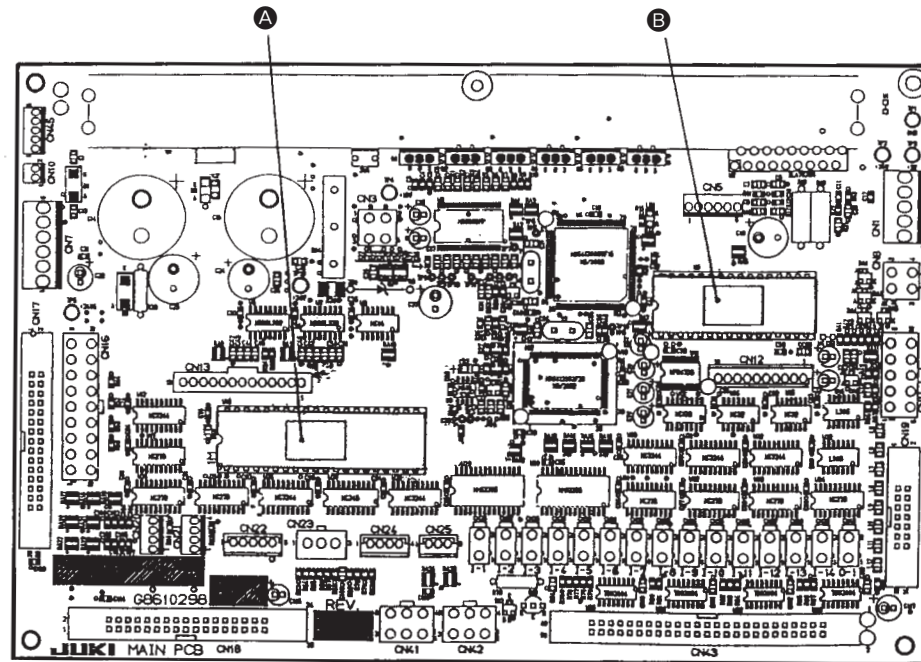

MAIN circuit board

There is a place, **C** where the EPROM is mounted in the PANEL-CTL circuit board.

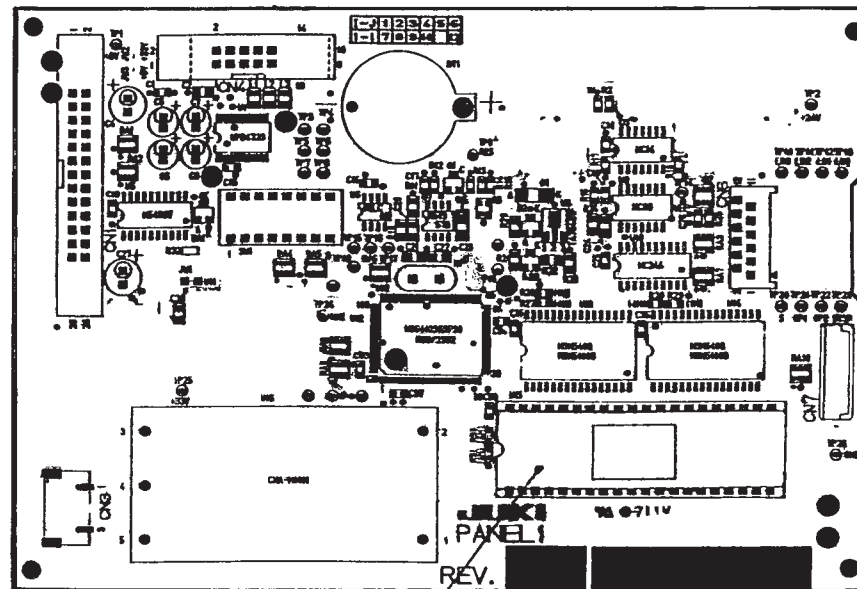

PANEL-CTL circuit board

There is a place, **D** where the EPROM is mounted in the SDC circuit board.

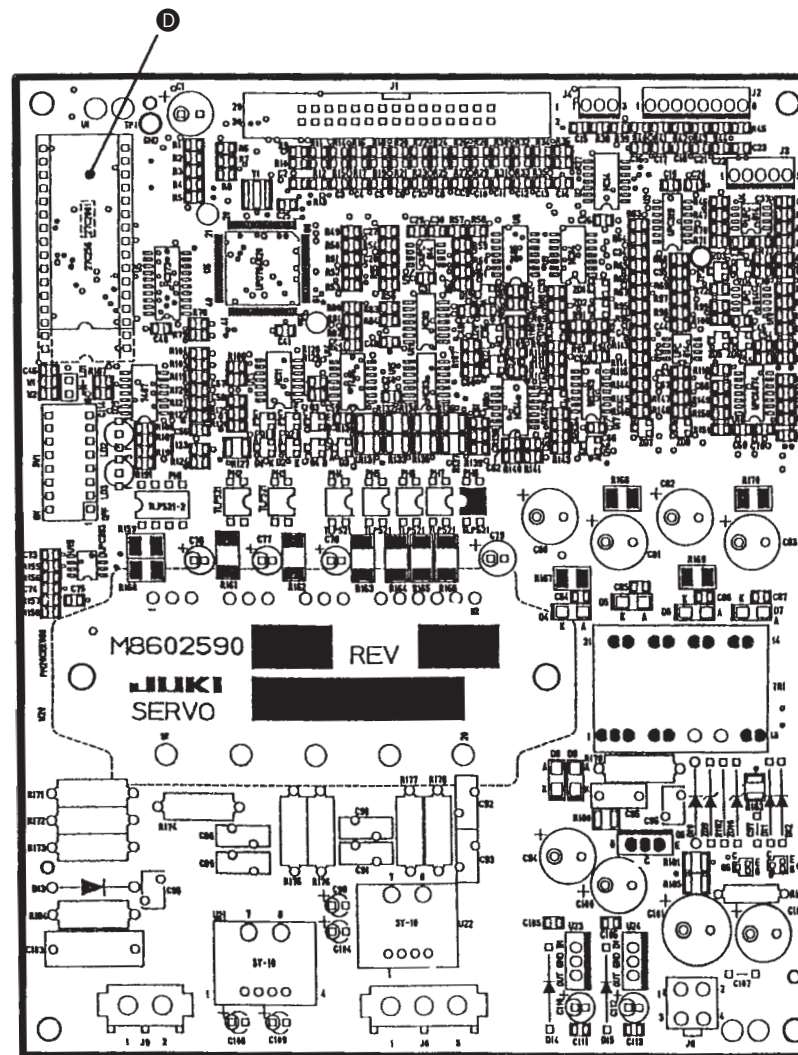

(3) Checking the set value of the power voltage and changing the voltage

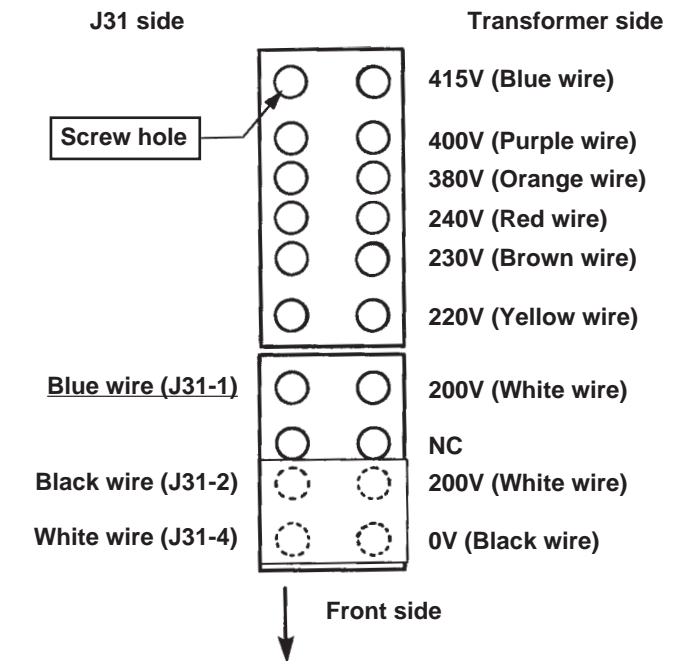

The power voltage is set by the blue wire on the J31 side of the terminal board connected as shown in the figure above. Accordingly, the example of the figure on the above shows the connection to the 200V power.

When changing the power voltage, it is necessary to change over the blue wire on the J31 side to the voltage tap to be used.

Check again that the power is turned OFF and connect the blue wire on the J31 side to the tap on the transformer side wire to which the same voltage as that to be used is described.

However, it is not necessary to change other wires. Fix the wires other than blue one.

(A caution seal is pasted on 0V and 200V sections on the front side of the power tap terminal board for prevention of mis-wiring.)

For these machine models, it is not necessary to change wiring in the control box due to the difference between single phase and 3-phase power source.

Re-setting on the power tap terminal board is required only when the change of the power voltage has occurred.

8. LIST OF ALARM CODES

An alarm No. is displayed on the display screen in the operation panel when an alarm has occurred.

Alarm No.	Description	
01	Temporary stop	
02	Trouble of servo motor for clamp foot travel See "MAIN circuit board alarm table".	
04	Detection of thread breakage	
05	Step-out of corner knife stepping motor	
06	Step-out of turret stepping motor	
08	Corner knife fails to lock.	
09	Failure in detection of corner knife being in the lower end position	
10	Failure in detection of center knife being in the upper end position	
11	Automatic welt patch and flap supply units are not in the correct home position.	
12	Trouble of needle up position	
13	Detection of dust on the front end of the flap	
14	Flap is not detected.	
15	Corner knife cannot move from the current position.	
16	Flap sensor fails to receive light.	
17	Position of the stacker is not correct.	
18	Trouble of the dart extending unit	
19	Binder is released.	
21	L size, outside the range of data	
23	Flap detecting speed, outside the range of setting	
26	Lockstitch pitch, outside the range of data	
27	Condensation pitch, outside the range of data	
28	Back tack pitch, outside the range of data	
29	Flap concealed stitching at the sewing start (right), outside the range of data	
30	Flap concealed stitching at the sewing end (right), outside the range of data	
31	Center knife at the sewing start, outside the range of data	
32	Center knife at the sewing end, outside the range of data	
34	Flap concealed stitching at the sewing start (left), outside the range of data	
35	Flap concealed stitching at the sewing end, outside the range of data	
36	Corner knife cutting length at the sewing start, outside the range of data	
37	Corner knife cutting length at the sewing end, outside the range of data	
38	Difference at the sewing start, outside the range of data	For APW-298 only
39	Difference at the sewing end, outside the range of data	For APW-298 only
40	Flap forced stop, outside the range of data	
41	Error in setting the stacker	
43	Error in setting the gauge size	
44	RAM error	
45	Error of the sensor to detect the front end and rear end of the clamp foot travel	
49	Needle thread breakage upper detection failure	
52	In the cycle sewing mode, the slant at the sewing start is set to a wrong direction.	For APW-298 only
53	In the cycle sewing mode, the front difference is set to an incorrect value.	For APW-298 only
54	In the cycle sewing mode, the slant at the sewing end is set to a wrong direction.	For APW-298 only

Alarm No.	Description	
55	In the cycle sewing mode, the rear difference is set to an incorrect value.	For APW-298 only
59	Pedal input error	
62	Corner knife selection, outside the range of data	
63	Number of stitches of back tack stitching at the sewing start, outside the range of data	
64	Number of stitches of back tack stitching at the sewing end, outside the range of data	
65	Condensation pitch at the sewing end, outside the range of data	
66	Back tack pitch at the sewing end, outside the range of data	
67	Malfunction of the welt patch cut unit	
68	Malfunction of the flap presser	
69	Trouble of stepping motor for adjusting the needle throw angle	
70	Main shaft motor driver is defective. (PSC is defective.)	
75	Sewing machine rotation at high speed, outside the range of data	
76	Sewing machine rotation at low speed, outside the range of data	
77	Sewing machine independent intermittent operation time 1, outside the range of data	
78	Sewing machine independent intermittent operation time 2, outside the range of data	
90	ROM version error of the main panel	
95	Communication error	

Check the alarm by the number of times of flashing on/off of the red LED (LD1) lamp on the MAIN circuit board.
Count the long flashing on/off as "1" time and the continuing short flashing on/off as "2" times. Continue to count the number of times of short flashing on/off as the number of times after "2" times.

Red LED (LD1) on MAIN circuit board

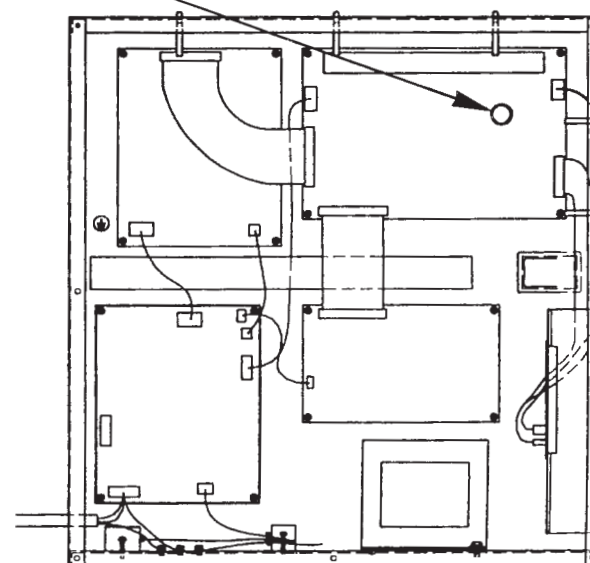

Electrical component box (control box)

- MAIN circuit board alarm table (See when "AL-02" has occurred.)
- 1 time : Motor-lock
- 2 times : Fuse has blown.
- 3 times : Defective power voltage Power voltage is outside the range.
- 4 times : Defective boosting voltage Trouble of pre-driver in the circuit board
- 5 times : Disconnection of the encoder cable
- 6 times : Detection of defective current of pre-driver
- 7 times : Defective temperature of pre-driver Abnormal rise of temperature inside the control box
- 8 times : Slip of the position of clamp foot
- 9 times : Overrun error of clamp foot
- 10 times : Overflow of accumulated pulses
- 11 times : Overload
- 12 times : Overload
- 13 times : Defective number of revolutions
- 14 times : System error

9. NAMES AND INSTALLING POSITIONS OF THE SWITCH SENSORS

No.	Name	Connecting connector NO.	Input No.	LED No.	Remarks
2	Needle thread breakage upper detection	MAIN CN27	I-2	-	
3	Binder lowering detection	MAIN CN28	I-3	-	
4	Corner knife fixed side lower detection	MAIN CN29	I-4	-	
5	Corner knife travel side lower detection	MAIN CN30	I-5	-	
6	Center knife upper detection	MAIN CN31	I-6	-	
7	Corner knife fixed side upper detection	MAIN CN32	I-7	-	
8	Corner knife travel side upper detection	MAIN CN33	I-8	-	
11	Dart extending upper detection	MAIN CN36	I-11	-	Optional
12	Binder upper detection	MAIN CN37	I-12	-	
13	Knife lock fixed side	MAIN CN38	I-13	-	Set for APW-298 only
14	Knife lock travel side	MAIN CN39	I-14	-	Set for APW-298 only
16	Needle feed adjustment origin	MAIN CN21	I-16	-	
17	Turret position detection	MAIN CN22	I-17	-	Set for APW-298 only
18	Corner knife origin	MAIN CN23	I-18	-	
19	Clamp foot rear end detection	MAIN CN24	I-19	-	
20	Clamp foot front end detection	MAIN CN25	I-20	-	
22	Flap detection, left	MAIN CN42	I-22	-	
23	Bobbin thread detection, right (Sensor amplifier)	MAIN CN41	I-23	-	
24	Bobbin thread detection, left (Sensor amplifier)	MAIN CN41	I-24	-	
25	Left needle thread breakage detection	MAIN CN8	I-25	-	
26	Right needle thread breakage detection	MAIN CN8	I-26	-	
27	Stacker close detection	MAIN CN20	I-27	-	Optional
29	Stacker origin	MAIN CN16	I-29	-	Optional
51	Binder open detection	I/O CN51	I-51	LD 22	
52	Binder oscillating end	I/O CN52	I-52	LD 23	
53	Binder supply end	I/O CN53	I-53	LD 24	
54	Welt patch presser lowering detection	I/O CN54	I-54	LD 25	Optional
55	Welt changeover switch	I/O CN55	I-55	LD 26	Optional
58	Automatic flap supply lower left end	I/O CN58	I-58	LD 29	Optional
59	Flap presser close	I/O CN59	I-59	LD 30	
61	Automatic flap supply raising	I/O CN61	I-61	LD 32	Optional
64	Welt patch cut motor origin	I/O CN64	I-64	LD 35	Optional
65	Welt patch set monitoring sensor	I/O CN65	I-65	LD 36	Optional
66	Bag cloth simultaneous sewing flap sensor	I/O CN66	I-66	LD 37	Optional
100	SDET sensor	MAIN CN45	-	-	1-75(UDET), 1-76(DDET) Creation signal

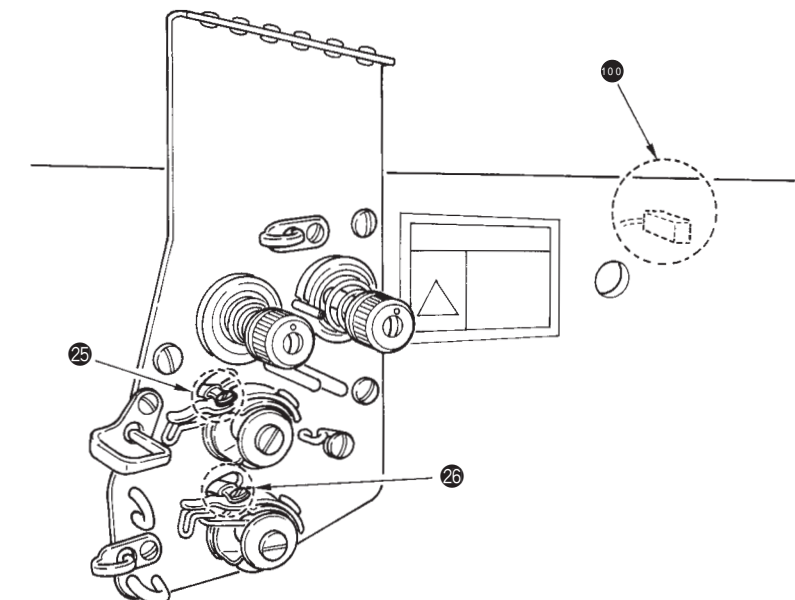
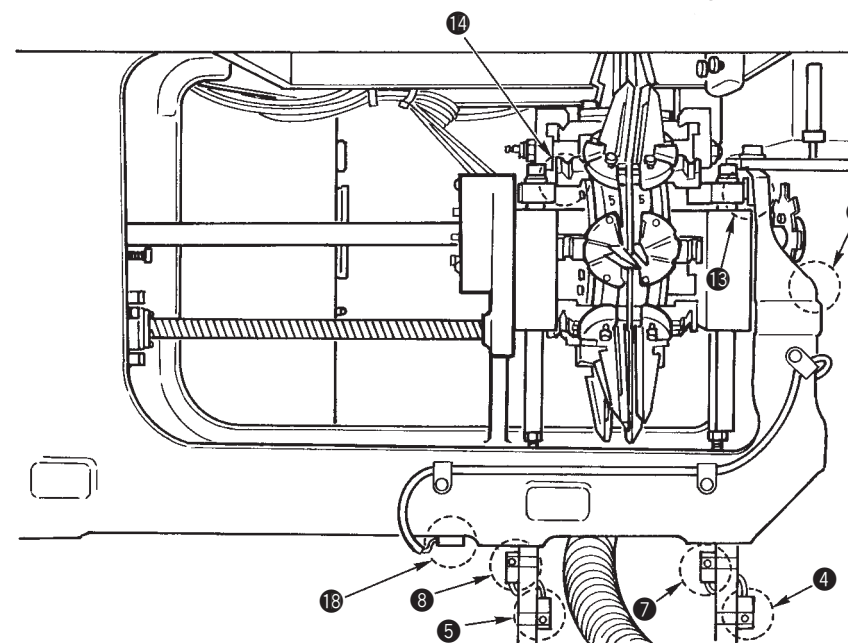
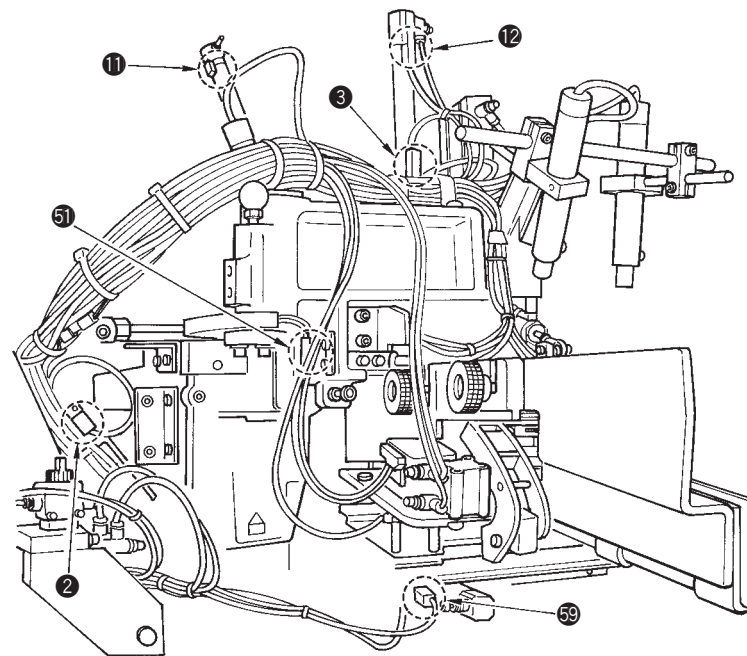
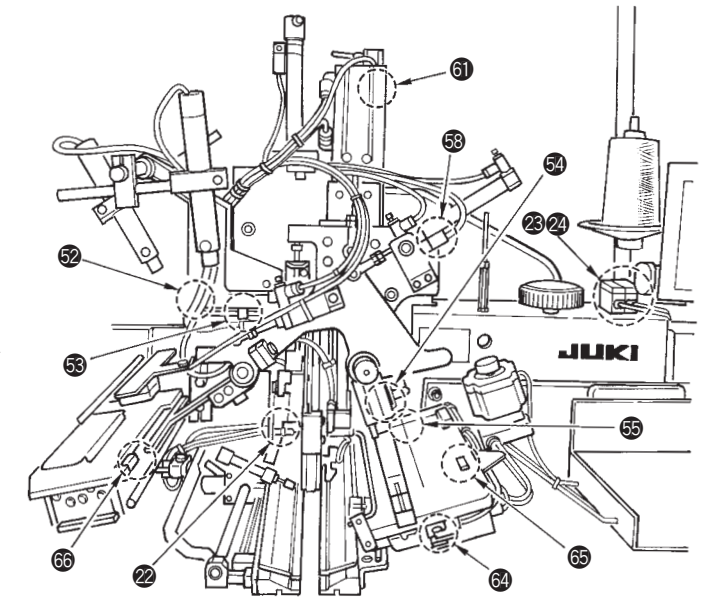
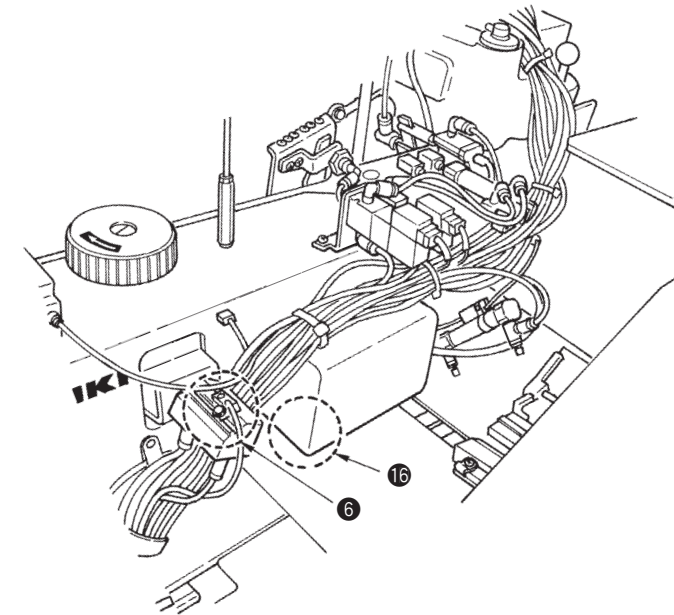
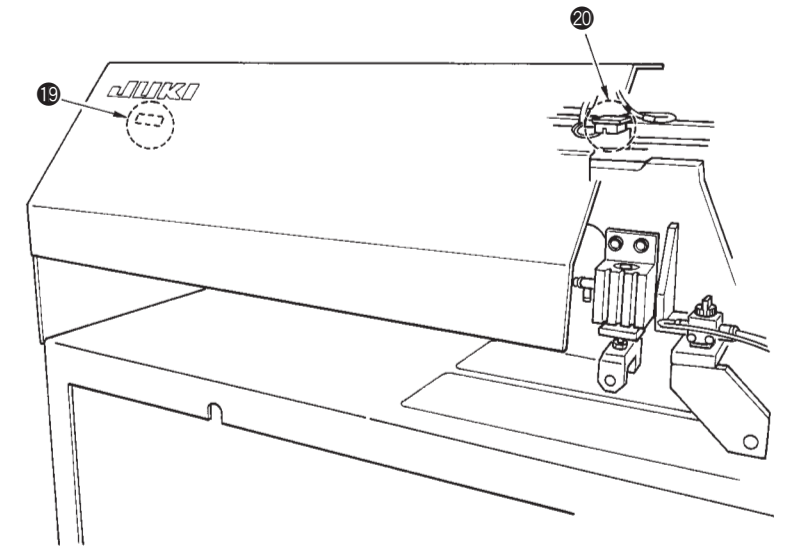
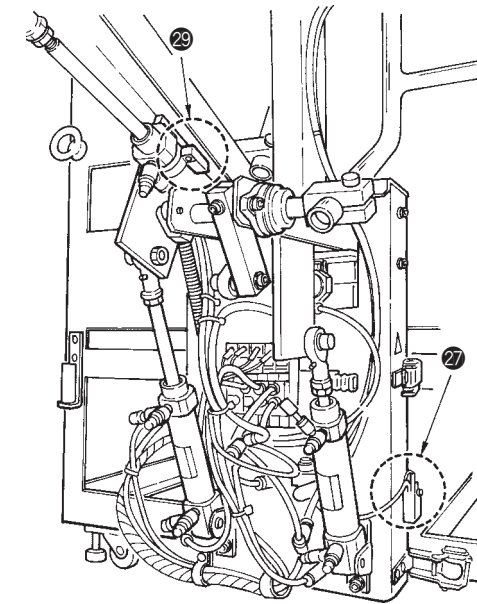

(1) Adjusting the flap sensor of the bag cloth flap supply unit

Schematic drawing of the bag cloth flap supply unit

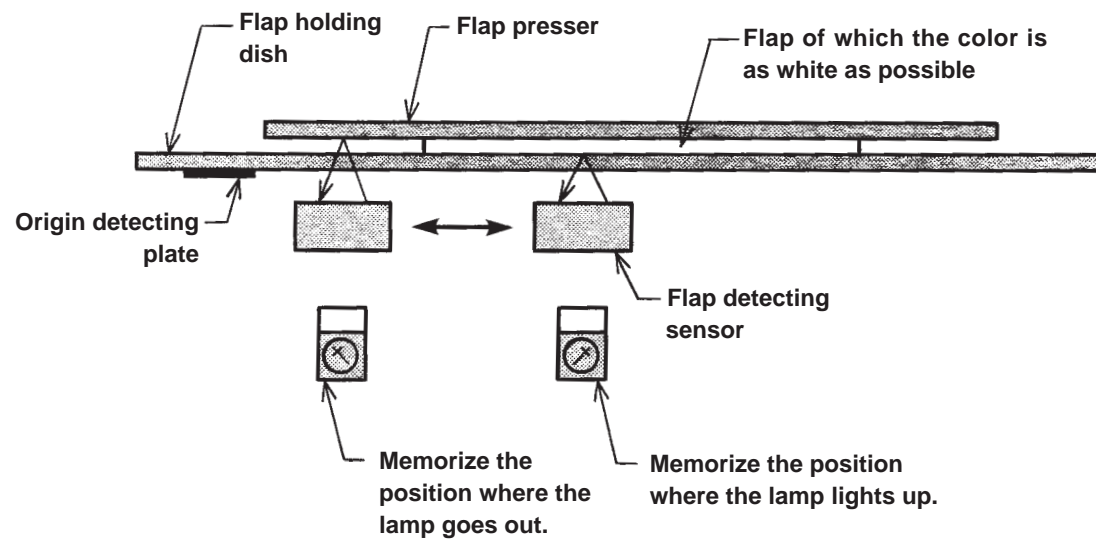

- 1) Turn ON the main power switch.
- 2) Place a pocket flap of which the color is as white as possible and the thickness is 1 mm to 1.5 mm on the flap holding dish.
- 3) Pressing the manual button of CN68-40 (left flap hold) of the solenoid valve unit located on the side of the head binder, turn it clockwise to lock. By this operation, the flap presser comes down and fixes the flap.
- 4) Fully take out the flap detecting sensor from under the origin detecting plate and move it to the position where it does not come under the flap.
It is possible to move the sensor by pressing with fingers since the motor for flap detecting sensor travel is not in the state of current-carrying.
- 5) Set the sensitivity adjusting VR (variable resistor) of the flap sensor to MAX., turn it counterclockwise and memorize the position where the red operation indicating lamp on the VR has gone out.
(In case where the lamp does not go out even when the VR is fully set to MIN., make the MIN. the point of memory.)
- 6) Further press the flap sensor with fingers and move it until the sensor fully enters under the flap.
- 7) Set the sensitivity adjusting VR of the flap sensor to MIN., turn it clockwise and memorize the position where the red operation indicating lamp has lit up.
(In case where the lamp does not light up even when the VR is fully set to MAX., make the MAX. the point of memory.)
- 8) Adjust the almost middle point of the respective memorized points as the set value of the sensitivity adjusting VR.
- 9) Release the lock of the manual button of the solenoid valve and remove the flap to complete the adjustment.

(Caution) This adjustment value is not necessary to re-adjust when it has been set once.

10. CIRCUIT DIAGRAM

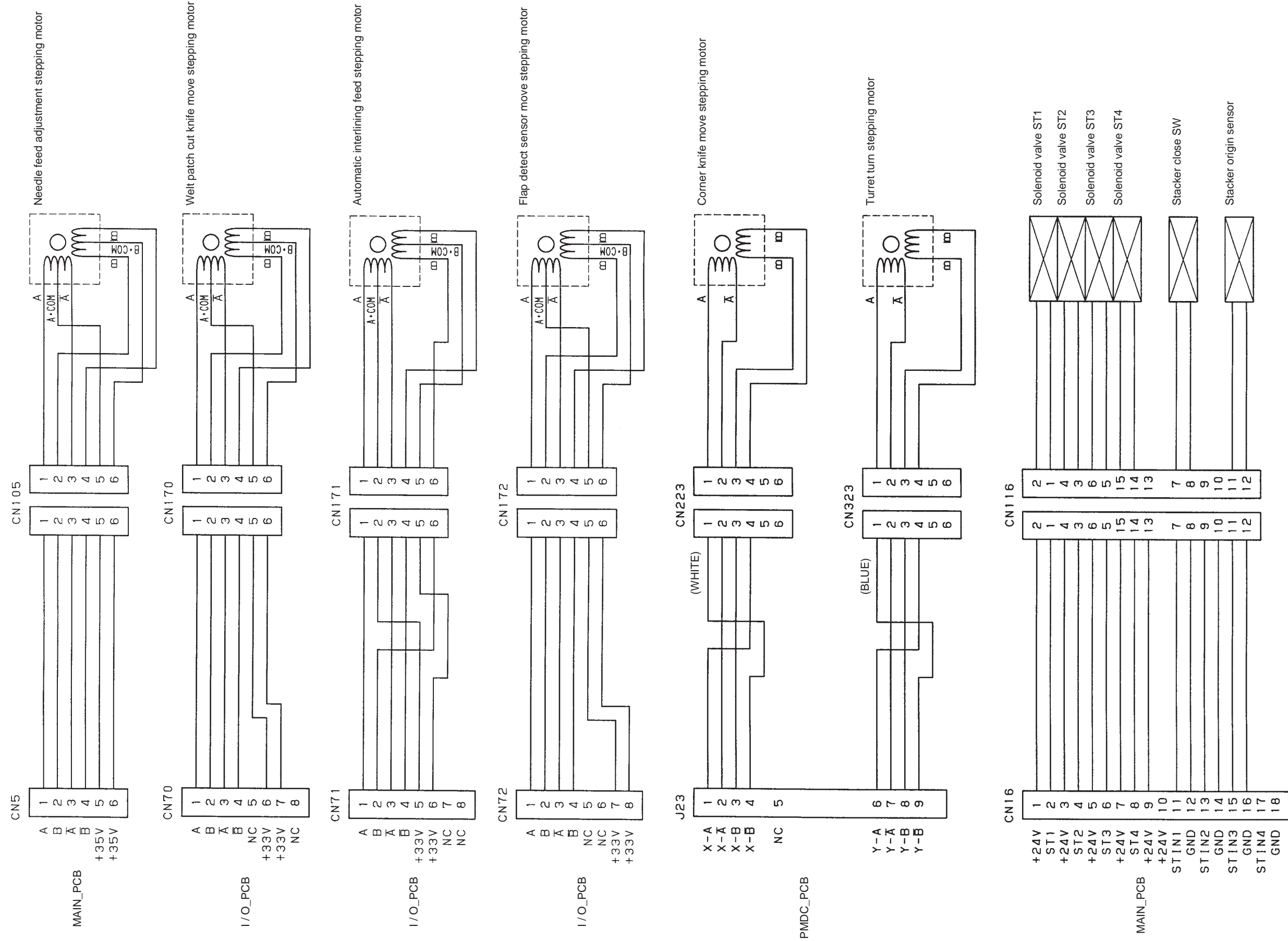

(1) Block diagram 1 / 2

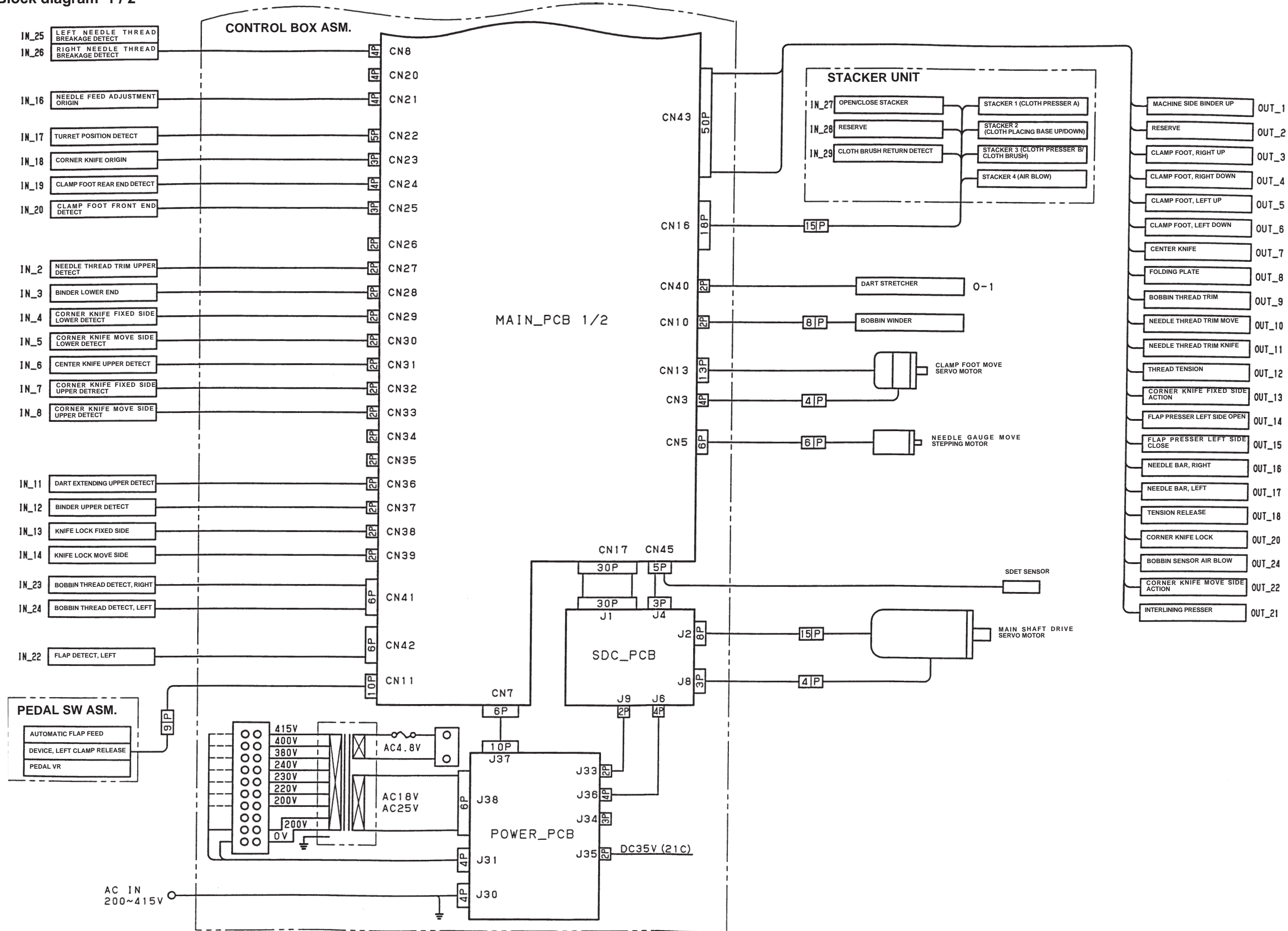

Block diagram 2 / 2

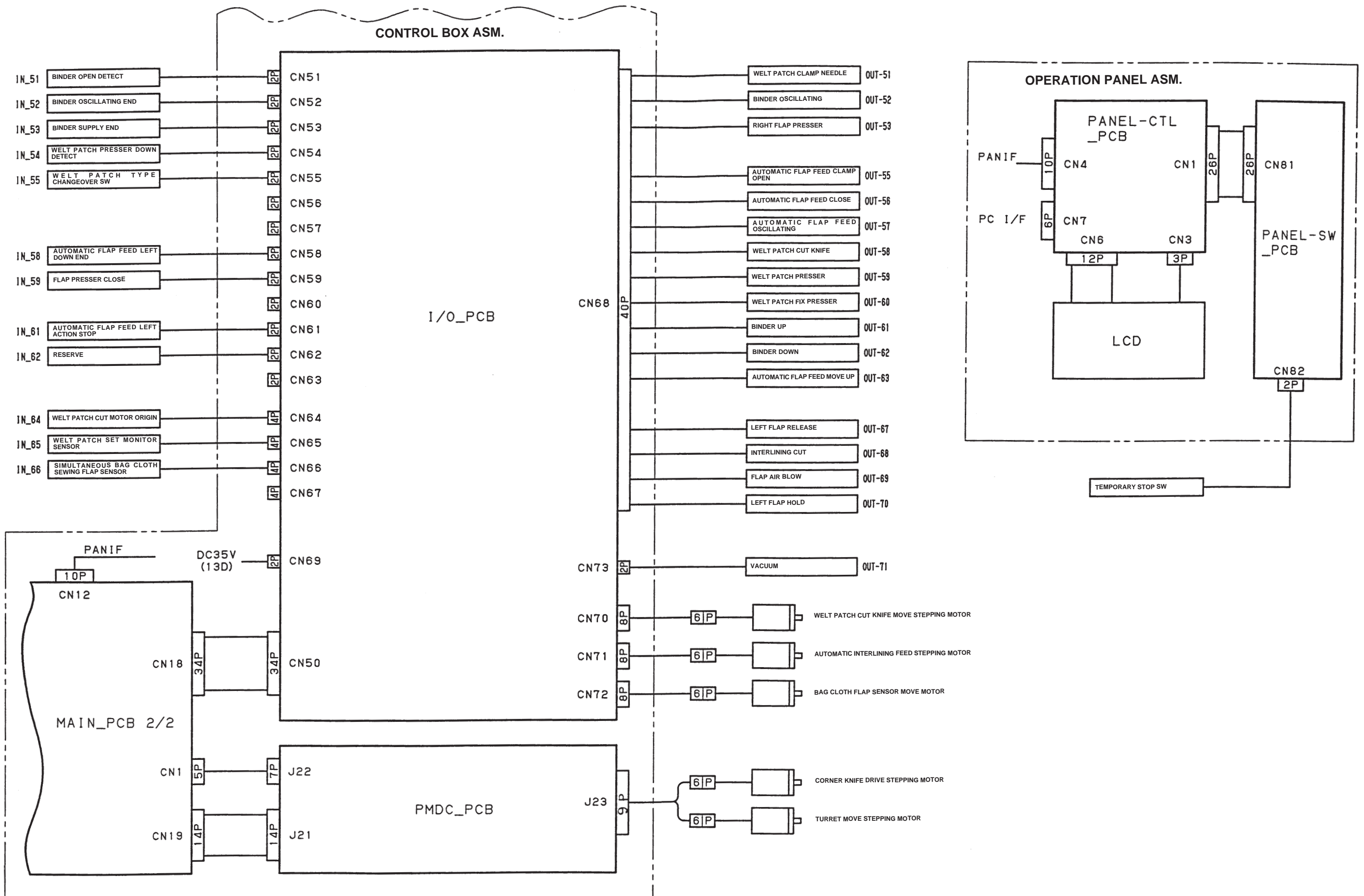

(2) Connection diagram

MAIN PCB

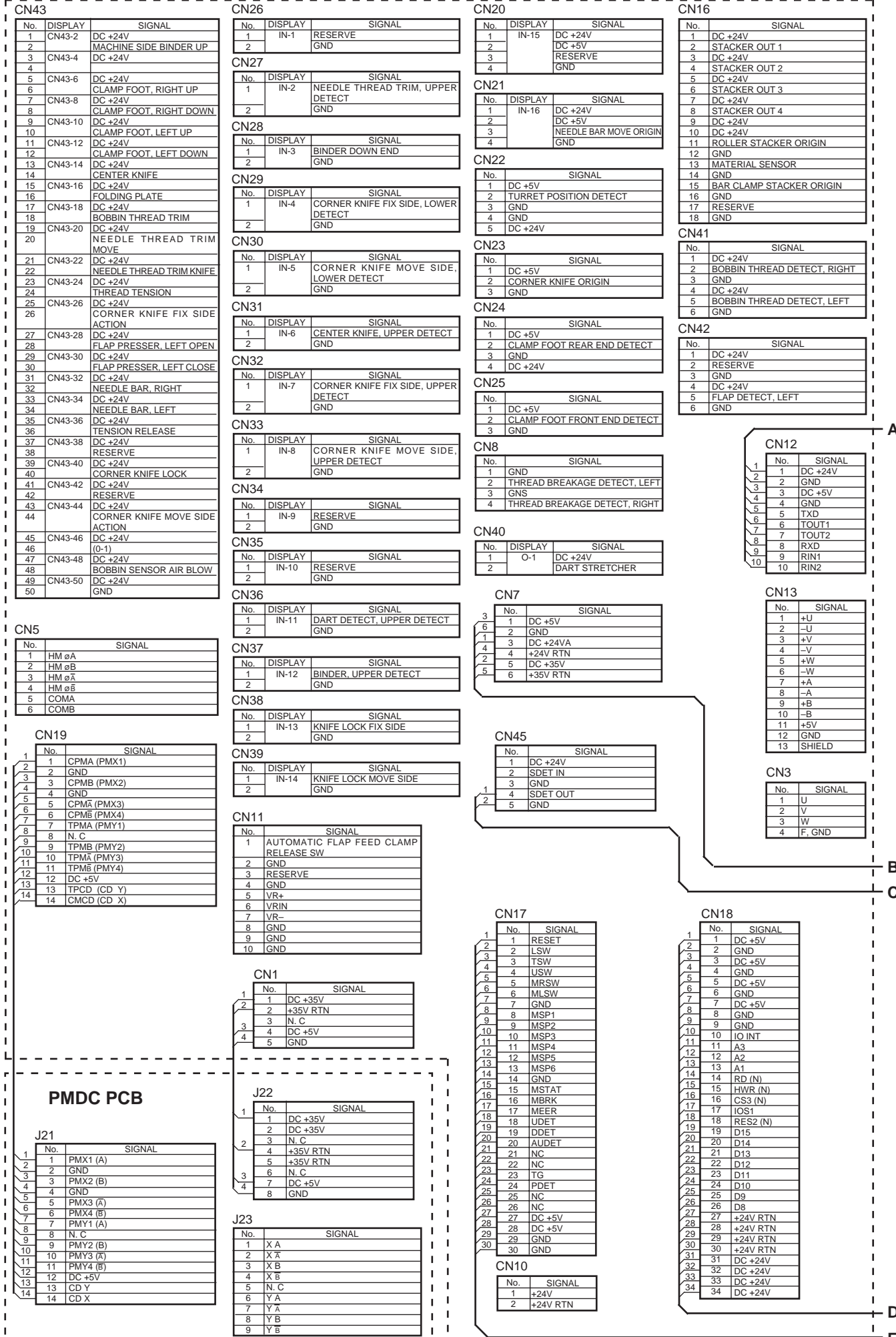

PANEL-CTL PCB

PANEL-SW PCB

CN4

No.	SIGNAL
1	PV (+24V)
2	GND
3	DC +5V
4	GND
5	TXD
6	TOUT1
7	TOUT2
8	RXD
9	RIN1
10	RIN2

CN1

No.	SIGNAL
1	RTN7
2	RTN6
3	RTN5
4	RTN4
5	RTN3
6	RTN2
7	RTN1
8	RTN0
9	SCN7
10	SCN6
11	SCN5
12	SCN4
13	SCN3
14	SCN2
15	SCN1
16	SCN0
17	VROUT
18	DC +5V
19	DC +5V
20	DC +24V
21	DC +24V
22	GND
23	GND
24	GND
25	GND
26	GND

CN81

No.	SIGNAL
1	RTN7
2	RTN6
3	RTN5
4	RTN4
5	RTN3
6	RTN2
7	RTN1
8	RTN0
9	SCN7
10	SCN6
11	SCN5
12	SCN4
13	SCN3
14	SCN2
15	SCN1
16	SCN0
17	VROUT
18	DC +5V
19	DC +5V
20	DC +24V
21	DC +24V
22	GND
23	GND
24	GND
25	GND
26	GND

CN6

No.	SIGNAL
1	S
2	CP1
3	CP2
4	NC
5	DISP OFF
6	D0
7	D1
8	D2
9	D3
10	VDD
11	VSS
12	VEE

CN3

No.	SIGNAL
1	VFT1
2	NC
3	VFT2

CN82

No.	SIGNAL
1	TEMPORARY STOP SW
2	RTN

CN7

No.	SIGNAL
1	DC +5V
2	GND
3	RXD
4	RIN
5	TXD
6	TOUT

J37

No.	SIGNAL
1	DC +24VA
2	DC +24VB
3	DC +35V
4	DC +24V
5	DC +5V
6	+24VA RTN
7	+24VB RTN
8	DC +24V
9	+24V RTN
10	GND

J38

No.	SIGNAL
1	NC
2	AC 25V
3	AC 25V
4	NC
5	AC 18V
6	AC 18V

J35

No.	SIGNAL
1	DC +33V
2	+33V RTN

J30

No.	SIGNAL
1	AC IN
2	AC IN
3	FG
4	FG

J31

No.	SIGNAL
1	AC TR_OUT
2	AC TR_IN
3	AC TR_IN
4	AC COM

J33

No.	SIGNAL
1	HV
2	HV_GND

J9

No.	SIGNAL
1	HV
2	HV_G

J36

No.	SIGNAL
1	DC +24V
2	GND
3	GND
4	GND

J6

No.	SIGNAL
1	DC +24V
2	GND
3	OCV
4	GND

J4

No.	SIGNAL
1	DC +5V
2	UDET
3	GND

J1

No.	SIGNAL
1	RESET
2	MLSW
3	MYSW
4	MUSW
5	MRSW
6	MLSW
7	GND
8	MSP1
9	MSP2
10	MSP3
11	MSP4
12	MSP5
13	MSP6
14	GND
15	MSTAT
16	MBRK
17	MEER
18	UDET
19	DDET
20	AUDET
21	ADDET
22	OP
23	TG
24	PDET
25	TRM
26	WPB
27	DC +5V
28	DC +5V
29	GND
30	GND

J8

No.	SIGNAL
1	U
2	V
3	W

J2

No.	SIGNAL
1	MB
2	MA
3	MZ
4	MU
5	MV
6	MW
7	DC +5V
8	GND

J3

No.	SIGNAL
1	MB
2	MA
3	MZ
4	UDET
5	GND

CN50

No.	SIGNAL
1	DC +5V
2	GND
3	DC +5V
4	GND
5	DC +5V
6	GND
7	DC +5V
8	GND
9	GND
10	IO INT
11	A3
12	A2
13	A1
14	RD (N)
15	HWR (N)
16	CS3 (N)
17	ISO1
18	RES2 (N)
19	D15
20	D14
21	D13
22	D12
23	D11
24	D10
25	D9
26	D8
27	+24V RTN
28	+24V RTN
29	+24V RTN
30	+24V RTN
31	DC +24V
32	DC +24V
33	DC +24V
34	DC +24V

CN69

No.	SIGNAL
1	DC +33V
2	+33V RTN

CN51

No.	DISPLAY	SIGNAL
1	IN-51	BINDER OPEN DETECT
2		GND

CN52

No.	DISPLAY	SIGNAL
1	IN-52	BINDER OSCILLATING END
2		GND

CN53

No.	DISPLAY	SIGNAL
1	IN-53	BINDER FEED END
2		GND

CN54

No.	DISPLAY	SIGNAL
1	IN-54	WELT PATCH PRESSER DOWN DETECT
2		GND

CN55

No.	DISPLAY	SIGNAL
1	IN-55	WELT TYPE CHANGEOVER SW
2		GND

CN56

No.	DISPLAY	SIGNAL
1	IN-56	RESERVE
2		GND

CN57

No.	DISPLAY	SIGNAL
1	IN-57	RESERVE
2		GND

CN58

No.	DISPLAY	SIGNAL
1	IN-58	AUTOMATIC FLAP FEEDER DOWN END_LEFT
2		GND

CN59

No.	DISPLAY	SIGNAL
1	IN-59	FLAP PRESSER CLOSE
2		GND

CN60

No.	DISPLAY	SIGNAL
1	IN-60	RESERVE
2		GND

CN61

No.	DISPLAY	SIGNAL
1	IN-61	AUTOMATIC FLAP FEEDER UP
2		GND

CN62

No.	DISPLAY	SIGNAL
1	IN-62	RESERVE
2		GND

CN63

No.	DISPLAY	SIGNAL
1	IN-63	RESERVE
2		GND

CN64

No.	DISPLAY	SIGNAL
1	IN-64	DC +5V
2		DC +24V
3		WELT PATCH CUT MOTOR ORIGIN
4		GND

CN65

No.	DISPLAY	SIGNAL
1	IN-65	DC +5V
2		DC +24V
3		WELT PATCH MONITOR SENSOR
4		GND

CN66

No.	DISPLAY	SIGNAL
1	IN-66	DC +5V
2		DC +24V
3		SIMULTANEOUS BAG CLOTH SEW FLAP SENSOR
4		GND

CN67

No.	DISPLAY	SIGNAL
1	IN-67	DC +5V
2		DC +24V
3		RESERVE
4		GND

CN68

No.	DISPLAY	SIGNAL
1	CN68-2	DC +24V
2	(OUT-51)	WELT PATCH CLAMP NEEDLE
3	CN68-4	DC +24V
4	(OUT-52)	BINDER OSCILLATING
5	CN68-6	DC +24V
6	(OUT-53)	RESERVE
7	CN68-8	DC +24V
8	(OUT-54)	RESERVE
9	CN68-10	DC +24V
10	(OUT-55)	AUTOMATIC FLAP FEED CLAMP OPEN
11	CN68-12	DC +24V
12	(OUT-56)	AUTOMATIC FLAP FEED CLAMP CLOSE
13	CN68-14	DC +24V
14	(OUT-57)	AUTOMATIC FLAP FEED OSCILLATING
15	CN68-16	DC +24V
16	(OUT-58)	WELT PATCH CUT KNIFE
17	CN68-18	DC +24V
18	(OUT-59)	WELT PATCH PRESSER
19	CN68-20	DC +24V
20	(OUT-60)	WELT PATCH FIXED PRESSER
21	CN68-22	DC +24V
22	(OUT-61)	BINDER UP
23	CN68-24	DC +24V
24	(OUT-62)	BINDER DOWN
25	CN68-26	DC +24V
26	(OUT-63)	AUTOMATIC FLAP FEED MOVE UP
27	CN68-28	DC +24V
28	(OUT-64)	RESERVE
29	CN68-30	DC +24V
30	(OUT-65)	RESERVE
31	CN68-32	DC +24V
32	(OUT-66)	RESERVE
33	CN68-34	DC +24V
34	(OUT-67)	RESERVE
35	CN68-36	DC +24V
36	(OUT-68)	INTERLINING CUT
37	CN68-38	DC +24V
38	(OUT-69)	FLAP AIR BLOW
39	CN68-40	DC +24V
40	(OUT-70)	LEFT FLAP HOLD

CN70

No.	SIGNAL
1	TCM - A
2	TCM - B
3	TCM - A
4	TCM - B
5	NC
6	+33V (COM - A)
7	+33V (COM - B)
8	NC

CN72

No.	SIGNAL
1	FSM - A
2	FSM - B
3	FSM - A
4	FSM - B
5	NC
6	NC
7	+33V (COM - A)
8	+33V (COM - B)

CN71

No.	SIGNAL
1	SKM - A
2	SKM - B
3	SKM - A
4	SKM - B
5	+33V (COM - A)
6	+33V (COM - B)
7	NC
8	NC

CN73

No.	DISPLAY	SIGNAL
1	OUT-71	DC +24V
2		VACUUM

I / O PCB

LEFT FLAP HOLD

11. TROUBLES AND CORRECTIVE MEASURES

(1) With regard to the machine head

Trouble	Cause (1)	Cause (2)	Checking order and corrective measures	
1. Thread breakage (needle thread)	1-1) The surface of the thread path of the needle thread has burrs or scratches.		Smooth the thread path (using a fine sandpaper and buff).	
	1-2) Needle thread tension is too high.	2)-A The tension of the thread tension disk is too high.	Decrease the tension. (See item "Needle thread tension" p.28.)	
		2)-B The tension of the thread take-up spring is too high.	Decrease the tension. (See item "Adjusting the tension of the thread take-up spring" p.28.)	
		2)-C The stroke of the thread take-up spring is too large or too small.	Correct the stroke. (See item "Adjusting the tension of the thread take-up spring" p.28.)	
	1-3) The clearance between the bobbin case opening lever and the bobbin case is improperly adjusted.		Provide a clearance of 0.2 to 0.3 mm between them. (See item "Adjusting the bobbin case opening lever" p.24.)	
	1-4) The hook has been improperly installed.	4)-A The needle comes in contact with the hook blade.	Correct the clearance between them. (See item "Adjusting the clearance between the needle and the hook blade point" p.24.)	
		4)-B The timing between the needle and hook is not correct.	Correct the timing. (See item "Adjusting the timing of the hook to the needle" p.24.)	
	1-5) Amount of oil in the hook is insufficient.		Adjust the amount of oil. (See item "Adjusting the amount of oil in the hook" p.26.)	
	2. Thread breakage (bobbin thread)	2-1) The bobbin thread is subjected to excessive tension.	1)-A The bobbin thread tension is too high.	Decrease the bobbin thread tension. (See item "Bobbin thread tension" described in Instruction Manual, p.13.)
			1)-B The clearance between the bobbin and bobbin case clogs with waste thread.	Remove waste thread.
1)-C The bobbin is deformed and fails to spin smoothly.			Replace the bobbin.	
3. Stitch skipping	3-1) The hook has been improperly installed.	1)-A The clearance between the needle and hook blade is too large.	Correct the clearance. (See item "Adjusting the clearance between the needle and the hook blade point" p.24)	
		1)-B The timing between the needle and hook is not correct.	Correct the timing. (See item "Adjusting the timing of the hook to the needle" p.24.)	
		1)-C Blunt hook blade point	Correct the hook blade point.	

▼ To the next page

Trouble	Cause (1)	Cause (2)	Checking order and corrective measures
	From the previous page		
	3-2) The needle guard is not properly adjusted.	2)-A The clearance between the needle and the needle guard is too large.	Correct the clearance. (See item "Adjusting the timing of the hook to the needle" p.24.)
		2)-B The needle and the needle guard are in excessive contact.	Correct the clearance. (See item "Adjusting the timing of the hook to the needle" p.24.)
	3-3) The longitudinal position of the needle bar frame is improper.		Correct its position. See item "Installing position of the needle bar frame" p.12.)
	3-4) The needle is defective.	4)-A The needle is bent or has a blunt point.	Replace the needle.
		4)-B The needle No. is not proper.	Replace the needle with a thicker one.
	3-5) The clearance between the sewing table and the binder is not correct.		Adjust the lowering position of the binder. (See item "Binder components" p.30 to 37.)
	3-6) The clamp foot does not clamp the garment properly.	6)-A The clamping pressure is not high enough.	Adjust the compressed air pressure to 0.5 MPa.
	3-7) The lockstitching speed is not correct.		Set stitch length to 2.0 mm.
4. Loose stitches	4-1) The needle thread tension is not high enough.		Increase the tension. (See item "Thread tension components" p.28.)
	4-2) The thread take-up spring is not properly adjusted.	2)-A The thread take-up spring tension is not high enough.	Increase the tension. (See item "Adjusting the tension of the thread take-up spring" p.28.)
		2)-B The stroke of the thread take-up spring is too small.	Correct the stroke. (See item "Adjusting the tension of the thread take-up spring" p.28.)
	4-3) The clearance between the bobbin case opening lever and the bobbin case is not correct.		Provide a clearance of 0.2 to 0.3 mm between them. (See item "Adjusting the bobbin case opening lever" p.24.)
	4-4) The clearance between the sewing table and the binder is not correct (too large).		Check the lowering position of the binder. (See item "Binder components" p.30 to 37.)

Trouble	Cause (1)	Cause (2)	Checking order and corrective measures
5. Needle breakage	5-1) The needle comes in contact with the hook blade point.		Correct the clearance between them. (See item "Adjusting the clearance between the needle and the hook blade point" p.24.)
	5-2) The needle comes in contact with the needle guard.		Correct the clearance between them. (See item "Adjusting the timing of the hook to the needle" p.24.)
	5-3) The needle comes in contact with the needle hole in the throat plate.		Correct the position of the needle bar frame. (See item "Installing position of the needle bar frame" p. 12.)
	5-4) The needle comes in contact with each unit.	4)-A The needle comes in contact with the binder.	Correct the position of the binder. (See item "Binder components" p. 30 to 37.)
		4)-B The needle comes in contact with the welt patch folding plate.	Correct the position of the welt patch folding plate. (See item "Adjusting the welt patch folding plate" p.42.)
	5-5) The lockstitching speed is too high.		Set the stitch length to 2.0 mm.
5-6) The needle is too thin for the material.		Replace the needle with a thicker one.	
6. Irregular stitches	6-1) Threading is wrong.	1)-A The threading route of the needle thread is wrong.	(See item "Threading the machine" described in Instruction Manual p.9.)
		1)-B The threading route of the bobbin thread is wrong.	(See item "Threading the bobbin case" described in Instruction Manual p.13.)
	6-2) The needle or bobbin thread tension is not correct.		Correct the needle or bobbin thread tension.
	6-3) The tension or stroke of the thread take-up spring is not correct.		Properly adjust the thread take-up spring. (See item "Adjusting the tension of the thread take-up spring" p.28.)
	6-4) The bobbin thread is wound up too tight.		Rewind the bobbin under proper tension.
	6-5) The bobbin thread feeding tension varies.	5)-A Waste thread exists between the bobbin and the bobbin case.	Remove the waste thread.
		5)-B The bobbin has been deformed and does not spin smoothly.	Replace the bobbin.
	7-1) Both the needle and bobbin thread tensions are too high.		Decrease the both thread tensions.
7-2) The needle is too thick for the material.		Replace the needle with a thinner one.	
7-3) The clearance between the welt patch base plate and the sewing table is not proper.		Properly adjust the clearance according to the material thickness. (See item "Binder components" p.30 to 37.)	

Trouble	Cause (1)	Cause (2)	Checking order and corrective measures
8. The thread slips off the needle at welting start.	8-1) The wiper is improperly positioned.		Correct its position. (See item "Adjusting the wiper" p.26.)
	8-2) The needle thread is not held properly.		Correct its position. (See item "Needle thread trimmer components" p.16 to 19.)
	8-3) The bobbin thread is not held properly.		Correct its position. (See item "Adjusting the bobbin thread knife" p.20.)
	8-4) The stop position of the sewing machine is not correct.		Correct its position. (See item "Adjusting the main shaft origin sensor" p.4.)
9. Several stitches are skipped at welting start.	9-1) The bobbin thread is too short.	1)-A The bobbin runs idle.	Increase the bobbin thread tension. Place a cloth under the bobbin to prevent it from running idle.
		1)-B The wiper improperly positioned.	Position it properly. (See item "Adjusting the wiper" p.26.)
10. Small wrinkles are produced on garment or welting patch. (Throughout the welting seam)	10-1) The center knife is dull.	1)-A The center knife is defective.	Replace the center knife. (See item "Adjusting the sharpness of the center knife" p.22.)
		1)-B The center knife has been improperly installed.	Install it correctly. (See item "Adjusting the sharpness of the center knife" p.22.)
	10-2) The needle is too thick or the needle point is blunt.		Use a thinner needle or replace the needle.
11. Needle threads are not trimmed.	11-1) The needle thread trimmer knife fails to work properly.	1)-A The needle thread trimmer knife has been improperly installed.	Correctly install the knife. (See item "Needle thread trimmer components" p.16 to 19.)
		1)-B The thread trimming cylinder fails to work properly.	Expel the compressed air from the cylinder to check whether the cylinder works under approx. 1.9kg or not. If the cylinder does not work smoothly, replace the cylinder. (Check the drain.)
12. Bobbin threads are not trimmed.	12-1) The knife is defective.	1)-A The pressure of the bobbin thread trimmer knife spring is not high enough.	Increase the spring pressure.
		1)-B The knife is dull.	Adjust the position of the bobbin thread trimmer knife. (See item "Adjusting the sharpness of the bobbin thread knife" p.21.)
	Turn the knife upside down or replace it.	Check the drain within the cylinder or replace the cylinder.	
	12-2) The bobbin thread trimming cylinder fails to work properly.		

(2) With regard to the unit

Trouble	Cause (1)	Cause (2)	Checking order and corrective measures
1. Welt widths on the right and left are not the same.	1-1) The clearance between the binder and the garment clamp is not properly adjusted.		Correct the clearance. (See item "Adjusting the garment clamp lifting amount" p.42.)
	1-2) The clearance between the needle and the welt patch folding plate is not properly adjusted.		Correct the clearance. (See item "Adjusting the welt patch folding plate" p.42.)
	1-3) The binder has been improperly positioned laterally.	3)-A The position of the front binder with regard to the needle has been slipped laterally.	Adjust the lateral position of the binder. (See item "Lateral adjustment of the front binder" p.30.)
		3)-B Both the front and rear binders have been slipped laterally.	Adjust the lateral position of the binder. (See items "Lateral adjustment of the front and rear binders" p.30, p.36.)
2. Welt widths in the front and rear are not the same.	2-1) Clearance between the binder and the garment clamp is not correct.		Correct the clearance. (See item "Adjusting the garment clamp lifting amount" p.42.)
	2-2) The clamp feet fail to travel in parallel to the binder.		Correct the position. (See items "Adjustment of torsion of the front and rear binders" p.30, p.34.)
	2-3) Welt patch cut position is not correct.	3)-A The front and rear cut positions of the welt patch are not in the center.	Correct the position. (See item "Welt patch cut unit" p.60.)
3. Welt patch interlining slips.	3-1) The front and rear binders are improperly positioned.	1)-A The heights of the front and rear binders at the time of jump feed are not the same.	Correct the position. (See items "Adjustment of height of the front and rear binders" p.32, p.36.)
		1)-B The lateral positions of the front and rear binders are not correct.	Correct the position. (See item "Lateral adjustment of front and rear binders" p.30, p.36.)
		1)-C Adjustment of the clearance between the front and the rear binders is not proper.	Correct the position. (See item "Front and rear binder components" p.30 to 36.)
4. Flap seam bends.	4-1) The pressing pressure of the flap presser is too low.		Correct the position. (See item "Adjustment of the flap presser" p.70.)
	4-2) The material guide is improperly adjusted.	2)-A The clearance between the material guide and the needle is too small.	Correct the position. (See item "Adjustment of material guide" p.32.)
		2)-B The clearance between the material guide and the welt patch base plate is too small.	Correct the position. (See item "Adjustment of material guide" p.32.)
	4-3) The needle thread trimmer knife is not properly adjusted.	3)-A The lateral position of the needle thread trimmer knife is not correct.	Correct the position. (See item "Needle thread trimmer components" p.16.)
		3)-B The height of the needle thread trimmer knife is not correct when it lowered.	Correct the position. (See item "Needle thread trimmer components" p.16.)

Trouble	Cause (1)	Cause (2)	Checking order and corrective measures
5. Flap interlining slackens.	5-1) Pressing pressure of the flap presser is not correct.	1)-A Pressing pressure is too low.	Correct the position. (See item "Adjustment of flap presser" p.70.)
	5-2) The position of the flap supply click is not correct. * Flap supply unit is optional.	2)-A The height of the supply click is not correct.	Correct the position. (See item "Flap supply unit" p.64.)
6. The interlining is not fed from the interlining feeding unit. * Interlining feeding unit is optional.	6-1) The clearance of the guide is not correct.	1)-A The clearance is too large.	Correct the position. (See item "Interlining feeding unit" p.80.)
		1)-B The clearance is too small.	
	6-2) The position of the guide is not correct.	2)-A The position of the counter knife and the guide is not correct.	Adjust the position of the guide. (See item "Interlining feeding unit" p.80.)
	6-3) The position of the guide roller or the interlining is not correct.		(See item "Interlining feeding unit" p.80.)
7. The cutting positions of the front and rear welt patch and the center knife are not the same. * Welt patch cut unit is optional.	7-1) The position of the welt patch cut unit is not correct.	1)-A The welt patch cut unit in terms of the binder is laterally slipped or tilted.	Correct the position. (See item "Welt patch cut unit" p.60.)
	7-2) The welt patch clamp needle fails to work properly.	2)-A Protruding amount of the welt patch clamp needle is insufficient.	Correct the position. (See item "Welt patch cut unit" p.60.)
		2)-B The welt patch clamp needle does not come out smoothly.	Check the welt patch clamp operation.
8. The front and rear welt patch cannot be cut sharply. * Welt patch cut unit is optional.	8-1) The welt patch cut knife is defective.	1)-A The knife has worn out.	Replace the welt patch cut knife.
	8-2) The position of the welt patch cut knife is not correct.	2)-A Protruding amount is not correct.	See item "Welt patch cut unit" p.60.
	8-3) Pressing pressure of the welt patch presser at the time of welt patch cut is not correct.	3)-A Inclination of the welt patch presser is not correct.	See item "Adjusting the welt patch presser" p.62.
		3)-B Inclination of the welt patch holding plate is not correct.	Adjust the welt patch holding plate.

(3) Electrical parts

It is likely that circuit board, sensor, etc. have been damaged when the trouble cannot be solved by referring to the item "Checking item and corrective measures". Replace the parts with those described in the item "Replacing part".

No	Trouble	Detailed state	Checking item and corrective measures	Replacing part
1	Alarm No. "AL-02" is displayed in the operation panel.	Check the alarm LED on MAIN circuit board.		Clamp foot servo motor
		Motor-lock of flashing once is displayed.	When clamp foot is heavy to be moved by hand, remove the mechanical cause. Connector CN103 or CN3 is likely to come off or the cable is likely to be disconnected. Connect it properly.	MAIN circuit board
		Blown fuse of flashing twice is displayed.	F4 fuse 10AT mounted on POWER circuit board has blown. Replace it. As the cause, clamp foot is likely to have collided with somewhere during operation. Check if there is any problem with the clamp foot.	Fuse MAIN circuit board
		Trouble of voltage of flashing 3 times is displayed.	Check the voltage used and the voltage changeover tap setting.	MAIN circuit board
		Trouble of boosting voltage of flashing 4 times is displayed.	MAIN circuit board is likely to have broken. Replace the circuit board.	MAIN circuit board
		Unconnected encoder cable of flashing 5 times is displayed.	Connecto CN13 is likely to come off or the cable is likely to be disconnected. Connect it properly.	MAIN circuit board
		Detection of voltage trouble of flashing 6 times is displayed.	MAIN circuit board is likely to have broken. Replace the circuit board.	MAIN circuit board
		Temperature trouble of flashing 7 times is displayed.	MAIN circuit board is likely to have broken. Replace the circuit board.	MAIN circuit board
		Slip of clamp foot of flashing 8 times is displayed.	Adjustment of clamp foot rear end sensor is likely to be not correct. Adjust the sensor properly. Check whether the sensor slit clogs with dust such as waste thread.	Clamp foot rear end sensor
		Clamp foot overrun of flashing 9 times is displayed.	Move clamp foot by hand and when the torque is largely uneven and particularly that on the top end is light, remove the mechanical cause.	MAIN circuit board Clamp foot servo motor
		Accumulated pulse overflow of flashing 10 times is displayed.	When clamp foot is heavy to be moved by hand, remove the mechanical cause.	
		Overload trouble of flashing 11 times is displayed.	When the trouble frequently occurs, MAIN circuit board is likely to have broken. Replace the circuit board.	
		Overload trouble of flashing 12 times is displayed.		
		Number of revolution trouble of flashing 13 times is displayed.		
		System error of flashing 14 times is displayed.		
2	Thread breakage detector operation is defective.	Needle thread breakage error is displayed even when needle thread is not broken.	Check the connection (resistance value) of thread breakage detecting plate and machine head (FG). Adjust so that the resistance value is "0"Ω between the machine head and the detecting plate when the thread take-up spring comes in contact with the detecting plate and the value is infinite when the thread take-up spring does not come in contact with the detecting plate.	Thread breakage detection unit
		Needle thread breakage detector fails to work even when needle thread is broken.	Re-adjust as mentioned above. Check the setting whether it is set to the effective side of thread breakage detection. (SW3 on the upper side of DIP switch located on the side of operation panel is ON.) Connector CN8 is likely to come off or the cable is likely to be disconnected. Connect it properly.	Thread breakage detection unit
3	Alarm No. "AL-05" is displayed in the operation panel.	Corner knife stepping motor runs.	The corner knife origin sensor input is likely to be defective. Check the input state of the display of operation panel.	Corner knife origin sensor
		Corner knife stepping motor fails to run.	Connector CNJ23 or CNJ123 is likely to come off, or the cable is likely to be disconnected. Connect it properly. Turn the motor shaft by hand and when the shaft is locked, remove the mechanical cause.	
4	Alarm No. "AL-06" is displayed in the operation panel.	Turret stepping motor runs.	The turret origin sensor input is likely to be defective. Check the input state of the display of operation panel.	Turret position detection sensor
		Turret stepping motor fails to run.	Connector J23 is likely to come off or the cable is likely to be disconnected. Connect it properly. Turn the motor shaft by hand and when the shaft is locked, remove the mechanical cause.	
5	Alarm No. "AL-08" is displayed in the operation panel.	Alarm fails to return.	The knife lock sensor input is likely to be defective. Check the input state of the display of operation panel.	Knife lock fixed side or travel side sensor
6	Alarm No. "AL-09" is displayed in the operation panel.	Alarm fails to return.	The corner knife lower detection sensor input is likely to be defective. Check the input state of the display of operation panel.	Corner knife lower detection sensor
7	Alarm No. "AL-10" is displayed in the operation panel.	Alarm fails to return.	The corner knife upper detection sensor input is likely to be defective. Check the input state of the display of operation panel.	Corner knife upper detection sensor
8	Alarm No. "AL-44" is displayed in the operation panel.	Alarm fails to return.	The memory on the panel CTL circuit board inside operation panel has broken down.	Panel CTL circuit board

No	Trouble	Detailed state	Checking item and corrective measures	Replacing part
9	Alarm No. "AL-45" is displayed in the operation panel.	Clamp foot travelled forward and the alarm has stopped.	Clamp foot front end sensor input is likely to be defective. Check the input state of the display of operation panel. Check whether the sensor slit clogs with dust such as waste thread or whether connector CN25 is properly connected.	Clamp foot front end sensor
		Clamp foot travelled backward and the alarm has stopped.	Clamp foot rear end sensor input is likely to be defective. Check the input state of the display of operation panel. Check whether the sensor slit clogs with dust such as waste thread or whether connector CN24 is properly connected.	Clamp foot rear end sensor
10	Alarm No. "AL-59" is displayed in the operation panel.	Trouble has occurred after replacing the circuit board.	When the panel CTL circuit board is replaced, perform re-adjustment of the pedal input.	Pedal SW
		Trouble has suddenly occurred.	Check the disconnection of pedal input wiring and the connection of cable CN11 and CN111.	
		Trouble has occurred after an extended period of disuse.	There is a possibility that the memory of pedal input set value has disappeared. Input the set value again. There is a danger that other adjustment values or sewing data have been disappeared or changed. Check them.	
11	Alarm No. "AL-69" is displayed in the operation panel.	Needle feed adjustment motor runs.	The needle feed adjustment origin sensor input is likely to be defective. Check the input state of the display of operation panel. Check whether the sensor slit clogs with dust such as waste thread or whether connector CN21 is properly connected.	Needle feed adjustment origin sensor
		Needle feed adjustment motor fails to run.	Connector CN5 or CN105 is likely to come off, or the cable is likely to be disconnected. Connect it properly. Turn the motor shaft by hand and when the shaft is locked, remove the mechanical cause.	Needle feed adjustment motor
12	Alarm No. "AL-70" is displayed in the operation panel.	Trouble has occurred immediately after turning ON the power.	Motor is likely to be locked. Turn the main shaft by hand and when it is heavy to be turned, remove the mechanical cause.	
			Power source is likely to be defective. Turn OFF the power and check again the power source voltage.	
			The sewing machine needle bar UP detection (SDET) sensor is likely to be defective. Check the sensor input.	SDET sensor
		Trouble has occurred during sewing.	Motor is likely to be locked. Turn the main shaft by hand and when it is heavy to be turned, remove the mechanical cause. Motor driver is likely to be defective.	SDC circuit board
13	Alarm No. "AL-90" is displayed in the operation panel.	ROM of the panel CTL circuit board has been replaced.	Malfunction occurs when the version of ROM which has been replaced is used with the version of ROM mounted on MAIN circuit board. It is not possible to combine with each other. It is necessary to return the previous ROM to its home position or to make the ROM on the MAIN circuit board side a ROM corresponding to the version.	EPROM
		ROM of the MAIN circuit board has been replaced.	Malfunction occurs when the version of ROM which has been replaced is used with the version of ROM mounted on the panel CTL circuit board. It is not possible to combine with each other. It is necessary to return the previous ROM to its home position or to make the ROM on the panel CTL circuit board side a ROM corresponding to the version.	
14	Alarm No. "AL-95" is displayed in the operation panel.	Alarm fails to return.	I/F cable between CN12 of MAIN circuit board and CN4 of panel CTL circuit board is likely to be defective. Check the connection or disconnection of the connectors.	
15	Power source has been changed.	Power voltage has been changed.	Any power source of 200V, 220V, 230V, 240V, 380V, 400V or 415V can be adapted by changeover of the transformer input tap. Perform the operation referring to the item "Change of the power voltage".	
16	Nothing is displayed in the operation panel.	Screen is light and the backlight is ON.	There is a possibility that fuse F6 (3A) mounted on POWER circuit board has blown. Check it.	Fuse
			Connector CN1 of panel CTL circuit board is likely to come off or the cable is likely to be disconnected. Connect it properly.	Panel CTL circuit board
		Screen is dark and the backlight is OFF.	There is a possibility that fuse F3 (10AT) mounted on POWER circuit board has blown. Check it.	Fuse
			Connector CN9 is likely to come off or the cable is likely to be disconnected. Connect it properly.	LCD (liquid crystal display) panel
17	Operation panel data has disappeared.	When the power is turned OFF, the set data cannot be saved.	Battery backup is likely to be defective. Replace the panel CTL circuit board.	Panel CTL circuit board
18	Alarm No. is displayed in the operation panel.	Check the alarm No. displayed in the operation panel and the input No. which is the cause of the alarm.	Check the alarm contents referring to the list of alarm codes and remove the cause of alarm. When the abnormal input No. () is displayed, perform checking of sensor cable and connector, and operation check of the actuator as the input state check.	
19	Others	All data which are currently set are desired to be saved.	An exclusive data input/output circuit board is required. Consult our JUKI service man.	
		The data is desired to be copied to the other machine.	An exclusive data input/output circuit board is required. Consult our JUKI service man.	

JUKI®

**Lockstitch Automatic Welting Machine
(With Automatic Welt Patch Feeder)**

APW-297(Flap Sewing Type)

APW-298 (Slant Pocket Sewing Type)

ENGINEER'S MANUAL

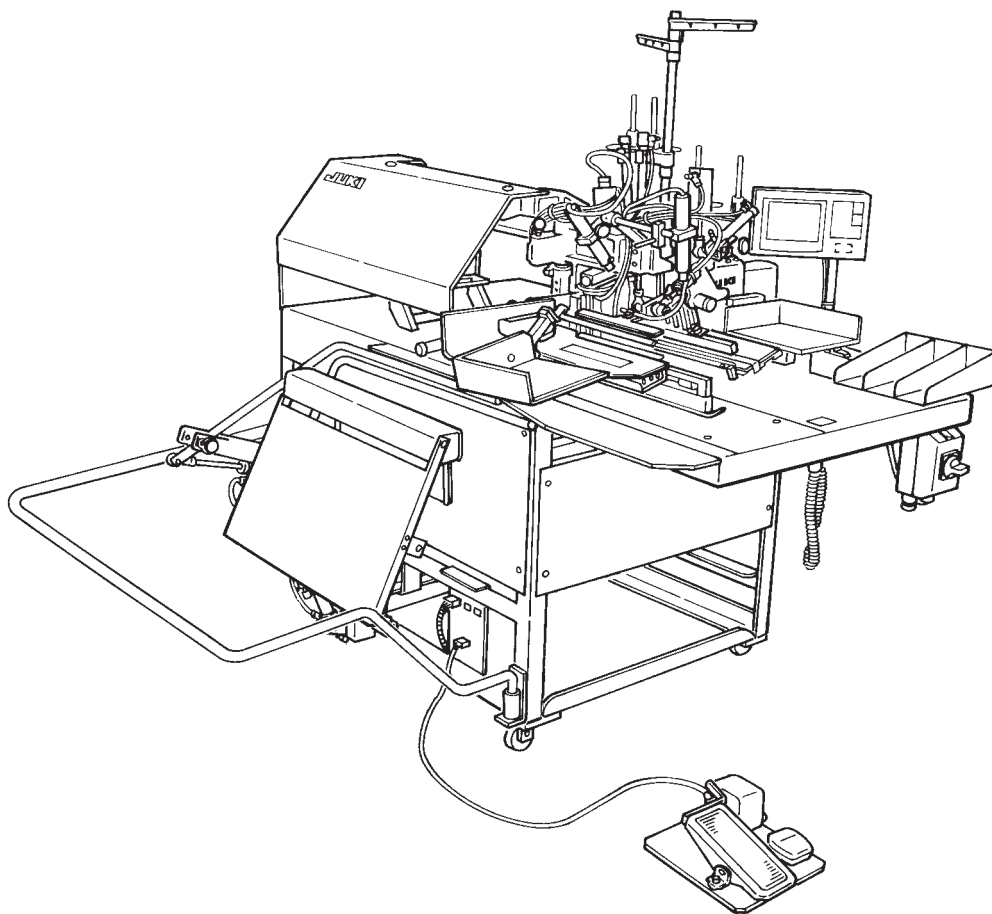

29346103

No.01

PREFACE

This Engineer's Manual is written for the technical personnel who are responsible for the service and maintenance of the sewing machine. This manual describes "Adjustment Procedure", "Results of Improper Adjustment", and other functions which are not covered by the Instruction Manual intended for the maintenance personnel and sewing operators at a sewing factory.

All personnel engaged in repair of APW-297, 298 are required to carefully read Section 2 "Standard Adjustment" which contains important information on the maintenance of APW-297, 298.

The "Standard Adjustment" consists of two parts ; the former part presents illustration and simplified explanation for the convenience of reconfirmation of the required adjustment values in carrying out actual adjustment after reading this manual once; and the latter part provides "Results of Improper Adjustment" in which sewing and/or mechanical failures, and the correcting procedures are explained for those persons who perform such adjustment for the first time.

It is advisable to use "APW-297, 298 Parts Book" together with this Engineer's Manual.

CONTENTS

1. SPECIFICATIONS	1
2. NAMES OF COMPONENTS	3
3. STANDARD ADJUSTMENTS	4
(1) Machine head components	4
1) Main shaft components	4
① Adjusting the main shaft origin sensor	4
② Replacing the timing belt	6
2) Needle bar components	8
① Adjusting the height of the needle bar (APW-297)	8
② Adjusting the upper/lower positions of the needle bar frame (APW-298)	8
3) Needle feed components	10
① Needle feed adjusting (cam section)	10
② Adjusting the installing position of the needle bar frame	12
③ Adjusting the timing of the needle feed operation	14
4) Needle thread trimmer components	16
① Adjusting the forward end position of the needle thread trimmer unit	16
② Adjusting the lateral position of the needle thread trimmer unit	16
③ Adjusting the width of the moving knife of the knife unit	18
④ Adjusting the fixed knife	18
5) Bobbin thread trimmer components	20
① Adjusting the bobbin thread knife	20
6) Center knife components	22
① How to adjust the height of the center knife	22
② How to adjust the distance from the needle to the center knife	22
③ Adjusting the sharpness of the center knife	22
④ Attaching the center knife	22
7) Hook components	24
① Adjusting the timing of the hook to the needle	24
② Adjusting the timing of the hook	24
③ Adjusting the clearance between the needle and the hook blade point	24
④ Removing and attaching the hooks	24
⑤ Adjusting the bobbin case opening lever	24
8) Wiper components	26
① Adjusting the wiper	26
9) Lubrication components	26
① Adjusting the injector for the reflux of the face plate components	26
10) Thread tension components	28
① Adjusting the thread take-up spring	28
② Adjusting the timing of the thread tension disc to start "floating"	28
(2) Device components	30
1) Binder components	30
① Front binder	30
② Rear binder	34
2) Clamp foot components	38
① Adjusting the tension of the clamp foot traveling belt	38
② Adjusting the tension of the clamp foot driving belt	38
③ Clamp foot front end stop position and rear end stop position	40
④ Adjusting the garment clamp lifting amount	42
⑤ Adjusting the welt patch folding plate and the flap presser	42
3) Corner knife components	44
① Corner knife mechanism of APW-297	44
② Corner knife mechanism of APW-298	48
③ How to set the corner knife on the knife base wheel	52
④ Adjusting the center of the corner knife	54
⑤ Adjusting the deflection and distortion of the corner knife	54
⑥ Adjusting the knife	54
⑦ Adjusting the corner knife for parallel sewing ..	56
⑧ Fine adjustment of corner knife in terms of seams ..	56
⑨ Adjusting the corner knife for slant sewing ..	58
(3) Optional components	60
1) Welt patch cut unit (right) : SA102	60
2) Flap supply unit (left) : SA103	64
3) Flap and bag cloth supply unit (left) : SA104	66
(a) Adjustment of the sensor slit	68
(b) Adjustment of belt tension	68
(c) Adjustment of flap presser	70
(d) Adjustment of flap holding dish	72
4) Dart extending unit : SA106	74
5) Suction unit : SA108	76
6) Interlining feeding unit : SA109	78
7) Single welt and double welt change unit (right) : SA111	82
8) Clamp bar stacker : SP44	84
4. OPERATION PANEL	88
(1) Operating the operation changeover screen ..	88
(2) Check program 8	89
(3) Initial setting table	90
1) <Sewing pattern screen>	90
2) <Counter screen>	92
3) <Adjustment data edit screen>	93
4) <Operation selection screen>	95
(4) Setting of DIP switches located in the rear of the panel	96
5. PARTS TO WHICH GREASE OR LOCKTITE IS APPLIED	97
6. AIR CIRCUIT DIAGRAM (APW-297, -298)	109
7. ELECTRICAL CONTROL BOX	110
(1) Explanation of components	110
1) Arrangement in the control box	110
2) Function and setting place of each circuit board	111
(2) Replacing the components	112
1) Replacing the fuse	112
2) Replacing the EPROM	113
(3) Checking the set value of the power voltage and changing the voltage	113
8. LIST OF ALARM CODES	114
9. NAMES AND INSTALLING POSITIONS OF THE SWITCH SENSORS	115
(1) Adjusting the flap sensor of the bag cloth flap supply unit	116
10. CIRCUIT DIAGRAM	117
(1) Block diagram 1 / 2	118
(2) Connection diagram	120
11. TROUBLES AND CORRECTIVE MEASURES	122
(1) With regard to the machine head	122
(2) With regard to the unit	126
(3) Electrical parts	128

JUKI®

JUKI CORPORATION

INTERNATIONAL SALES H.Q.
8-2-1, KOKURYO-CHO,
CHOFU-SHI, TOKYO 182-8655, JAPAN
PHONE : (81)3-3430-4001 to 4005
FAX : (81)3-3430-4909 • 4914 • 4984
TELEX : J22967

Copyright © 2000 JUKI CORPORATION.
All rights reserved throughout the world.



Please do not hesitate to contact our distributors or agents in your area for further information when necessary.
* The description covered in this engineer's manual is subject to change for improvement of the commodity without notice.