

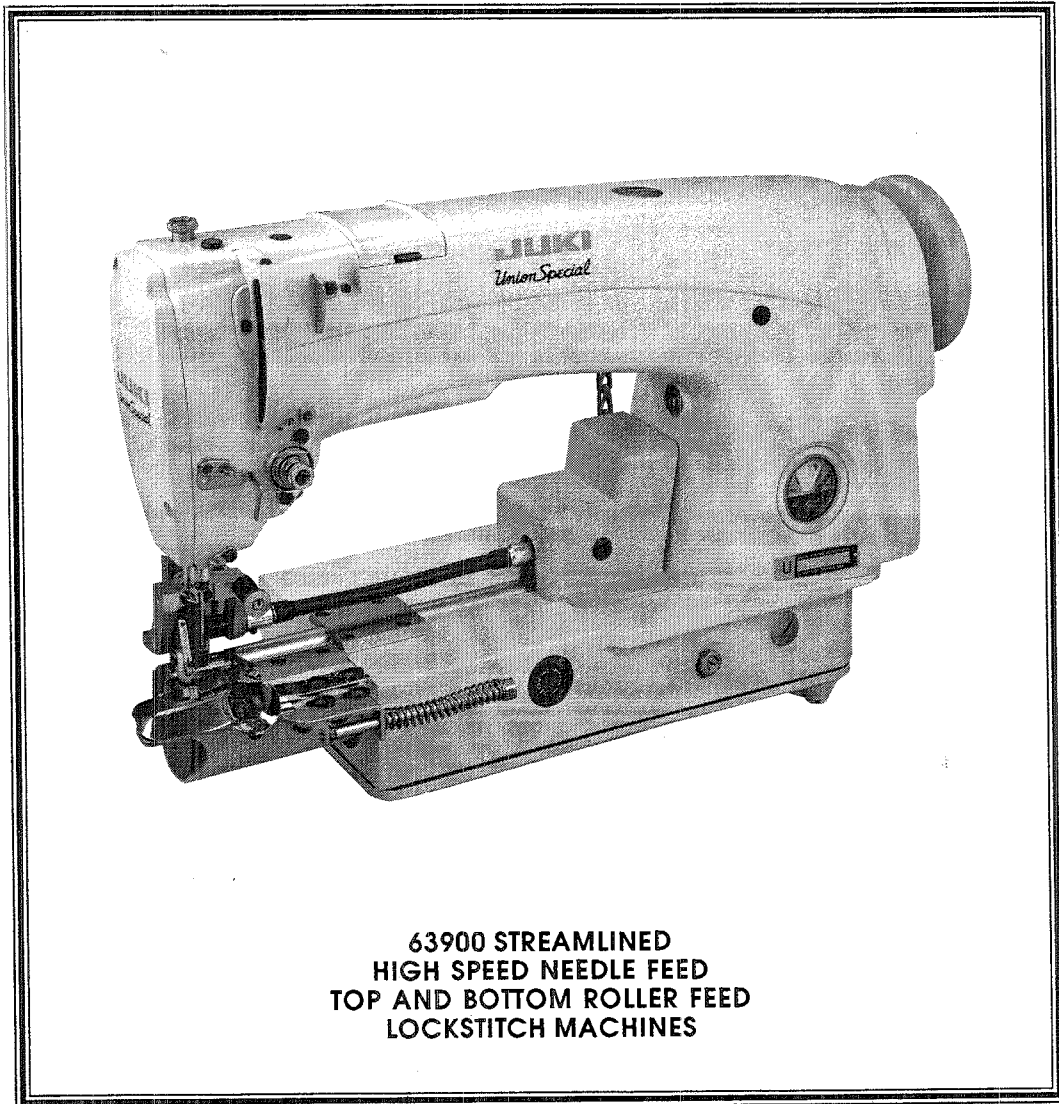

*Union Special*  
INDUSTRIAL SEWING EQUIPMENT

ADJUSTING INSTRUCTIONS / ILLUSTRATED PARTS LIST



63900 STREAMLINED  
HIGH SPEED NEEDLE FEED  
TOP AND BOTTOM ROLLER FEED  
LOCKSTITCH MACHINES

MANUAL NO. PT9636

STYLES

63900AM  
63900AML  
63900AT  
63900AW  
63900AAE

## CONTENTS

• PREFACE .....	4
• SAFETY RULES .....	5
• IDENTIFICATION OF MACHINES .....	6
• CLASS DESCRIPTION .....	6
• STYLE OF MACHINES .....	6
• ILLUSTRATIONS .....	6
• ILLUSTRATIONS (CONT.) .....	7
• IDENTIFYING PARTS .....	7
• NEEDLES .....	7
• TABLEBOARD .....	8
• BOBBIN WINDER .....	8
• BELTS .....	8
• LUBRICATION .....	9
• RECOMMENDED OIL .....	9
• OIL GAUGE .....	9
• SELF-PRIMING HEAD OIL SIPHON .....	10
• INSTALLING AND MAINTENANCE OF OIL SIPHON .....	10
• THREAD .....	11
• REMOVING THE BOBBIN CASE .....	11
• WINDING THE BOBBIN .....	11
• THREADING THE BOBBIN CASE .....	11
• THREADING THE BOBBIN CASE (CONT.) .....	12
• REPLACING THE BOBBIN CASE .....	12
• INSERTING THE NEEDLE .....	12
• THREADING THE NEEDLE .....	12
• PREPARATION FOR SEWING .....	12
• TENSIONS .....	12
• BOBBIN THREAD TENSION .....	12
• BOBBIN THREAD TENSION (CONT.) .....	13
• NEEDLE THREAD TENSION .....	13
• CHANGING THE STITCH LENGTH .....	13
• TIMING THE NEEDLE FEED WITH THE CONTINUOUS TURNING ROLLER FEED .....	14
• PRESSURE ON MATERIAL .....	14
• SETTING THE NEEDLE BAR TO HEIGHT .....	14

## CONTENTS (CONT.)

•TIMING THE HOOK .....	15
•NEEDLE GUARD INSTRUCTIONS .....	15
•NEEDLE GUARD INSTRUCTIONS (CONT.) .....	16
•HOOK LUBRICATION .....	16
•PRESSER BAR GUIDE .....	16
•PRESSER BAR CONNECTION .....	16
•TENSION ASSEMBLY ADJUSTMENT .....	17
•TENSION RELEASE .....	17
•THREAD CONTROL .....	17
•THREAD CONTROL (CONT.) .....	18
•BOTTOM COVER .....	18
•HOOK SHAFT .....	18
•HOOK SHAFT (CONT.) .....	19
•REMOVAL OF OILING DEVICE .....	19
•REASSEMBLY OF OILING DEVICE .....	20
•REASSEMBLY OF OILING DEVICE (CONT.) .....	21
•UPPER MAIN SHAFT .....	21
•UPPER MAIN SHAFT (CONT.) .....	22
•HANDWHEEL .....	22
•HANDWHEEL (CONT.) .....	23
•ATTACHMENTS .....	23
•NEEDLE HOLE INSERT .....	23
•MAINFRAME, BUSHING, OIL GAUGE HEAD OIL SIPHON AND MISCELLANEOUS OILING PARTS .....	25
•MAINFRAME, BUSHING, OIL GAUGE HEAD OIL SIPHON AND MISCELLANEOUS OILING PARTS (CONT.) .....	27
•MAIN FRAME MISCELLANEOUS COVERS AND NEEDLE TENSION PARTS .....	29
•MAIN FRAME MISCELLANEOUS COVERS AND NEEDLE TENSION PARTS (CONT.) .....	31
•MAIN AND HOOK DRIVE SHAFTS, NEEDLE BAR AND FOOT LIFTER MECHANISM .....	33
•NEEDLE FEED DRIVING PARTS .....	35
•PRESSER FEET, PRESSER BAR, TOP FEED ROLLER MECHANISM AND ATTACHMENTS .....	37
•PRESSER FEET, PRESSER BAR, TOP FEED ROLLER MECHANISM AND ATTACHMENTS .....	39
•ROTATING HOOK ASSEMBLY AND HOOK OILING PARTS .....	41
•FEED ROLLER DRIVING PARTS .....	43
•FEED ROLLER DRIVING PARTS (CONT.) .....	45
•BOBBIN WINDER AND MISCELLANEOUS ACCESSORIES .....	47
•NUMERICAL INDEX OF PARTS .....	48
•NUMERICAL INDEX OF PARTS .....	49
•NOTES .....	50
•NOTES .....	51

# Manual No. PT9636 Illustrated Parts List for 63900 Series Machines

---

---

First Edition Copyright 1997

By

Union Special Corporation Rights Reserved In All Countries

Printed in U.S.A. October 1997

---

---

## PREFACE

This parts manual has been prepared to assist you in locating individual parts or assemblies on 63900 Series machines.

It is the desire of Union Special that each machine run at its optimum performance. Parts listed in this manual are designed specifically for your machine and are manufactured with utmost precision to assure long lasting service.

This manual has been comprised on the basis of available information. Changes in design and/or improvements may incorporate a slight modification of configuration in illustrations or part numbers.

On the following pages are illustrations and terminology used in describing the parts used on 63900 Series machines.

---

---



## SAFETY RULES

1. Before putting the machines described in this manual into service, carefully read the instructions. The starting of each machine is only permitted after taking notice of the instructions and by qualified operators.

**IMPORTANT!** Before putting the machine into service, also read the safety rules and instructions from the motor supplier.

2. Observe the national safety rules valid for your country.
3. The sewing machines described in this instruction manual are prohibited from being put into service until it has been ascertained that the sewing units which these sewing machines will be built into, have conformed with the EC Council Directives (89/392/EEC, Annex II B).

Each machine is only allowed to be used as foreseen. The foreseen use of the particular machine is described in paragraph "STYLES OF MACHINES" of this instruction manual. Another use, going beyond the description, is not as foreseen.

4. All safety devices must be in position when the machine is ready for work or in operation. Operation of the machine without the appertaining safety devices is prohibited.
5. Wear safety glasses.
6. In case of machine conversions and changes all valid safety rules must be considered. Conversions and changes are made at your own risk.
7. The warning hints in the instructions are marked with one of these two symbols:



8. When doing the following the machine has to be disconnected from the power supply by turning off the main switch or by pulling out the main plug:
  - 8.1 When threading needle(s), looper, spreader etc.
  - 8.2 When replacing any parts such as needle(s), presser foot, throat plate, looper, spreader, feed dog, needle guard, folder, fabric guide etc.
  - 8.3 When leaving the workplace and when the workplace is unattended.
  - 8.4 When doing maintenance work.
  - 8.5 When using clutch motors without actuation lock, wait until the motor is stopped totally.
9. Maintenance, repair and conversion work (see item 8) must be done only by trained technicians or special skilled personnel under consideration of the instructions.
10. Any work on the electrical equipment must be done by an electrician or under direction and supervision of special skilled personnel.
11. Work on parts and equipment under electrical power is not permitted. Permissible exceptions are described in the applicable sections of standard sheet DIN VDE 0105.
12. Before doing maintenance and repair work on the pneumatic equipment, the machine has to be disconnected from the compressed air supply. In case of existing residual air pressure, after disconnecting from compressed air supply (i.e. pneumatic equipment with air tank), the pressure has to be removed by bleeding.



## IDENTIFICATION OF MACHINES

Each UNION SPECIAL machine is identified by a style number, which is stamped into the style plate affixed to the middle of the machine under the tension assembly. The serial number is stamped into the serial number plate affixed to the right rear base of the machine.

### CLASS DESCRIPTION

High speed streamlined long arm needle feed lockstitch machines. one needle, light, medium and heavy duty, continuous running roller feed, rotary hook, horizontal hook shaft, gears for changing stitch length, slot segment for adjusting needle feed, 1 1/4 inch needle bar travel, one reservoir enclosed automatic lubrication system, head oil siphon, adjustable hook oil control, needle bearing for take-up lever and needle bar driving link, needle feed timing on upper shaft, maximum work space to right of needle bar 8 inches.

### STYLE OF MACHINES

- 63900AM For making 3/8 on 1/2 inch turned down hem on legs of overalls, coveralls, and dungarees. Seam Specification 301-EFb-1 inverted, Specify size of hem. Maximum recommended speed 5200 R.P.M.
- 63900AML Same as 63900AM except includes a hook with 52% greater bobbin capacity to reduce frequency of bobbin changes.
- 63900AT For making a 1/2 or 2 1/2 inch hem turned by hand on children's wear, men's dress pants, semi-dress pants and work pants. Sewn when garment reaches machine inside out. Seam Specification 301EFb-1 or EFa-1. Maximum recommended speed 5200 R.P.M.
- 63900AW For top stitching waistbands on twill and woolen pants. Machine equipped to sew over belt loops. Fitted with cloth plate extension. Seam Specification 301-SSa-1. Maximum recommended speed 5200 R.P.M.
- 63900AAE Same as Style 63900AW, except fitted with spring guide keel on presser foot in line with centerline of needle hole.

### ILLUSTRATIONS

This manual has been arranged to simplify ordering repair parts. Exploded views of various sections of the mechanism are shown so that the parts may be seen in their actual position in the machine. On the page opposite the illustration will be found a listing of the parts with their part numbers, description and the number of pieces required in the particular view being shown.

Numbers in the first column are reference numbers only, and merely indicate the position of the part in the illustration. The reference number should never be used in ordering parts. Always use the part number listed in the second column.

Component parts of sub-assemblies which can be furnished for repairs are indicated by indenting their descriptions under the description of the main sub-assembly. As an example refer to the following text.

- |             |   |   |
|-------------|---|---|
| 18. 29126EL | Needle Feed Driving Eccentric and Connecting Rod Assembly ..... | 1 |
| 19. 22894J  | Set Screw .....   | 2 |



## ILLUSTRATIONS (CONT.)

When a part is common to all machines covered in this manual, no specific usage will be mentioned in the description. However, when the parts for the various machines are not the same, the specific usage will be mentioned in the description and, if necessary, the difference will be shown in the illustration.

\*Ref. No. showing no Part No. is for location only. Part is not for sale separately.

A numerical index of all the parts shown in this manual is located at the back. This will facilitate locating the illustration and description when only a part number is known.

## IDENTIFYING PARTS

Where construction permits, each part is stamped with its part number. On some of the smaller parts and on those where construction does not permit, an identification letter is stamped in to distinguish the part from similar ones.

**PLEASE NOTE:** Part numbers represent the same part, regardless of which manual they appear. On all orders please include part number, name and style of machine for which the part was ordered.

For optimum performance use only genuine Union Special replacement parts.

## NEEDLES

Each needle has both a type and size number. The type number denotes the kind of shank, point, length, groove, finish and other details. The size number, stamped on the needle shank, denotes the largest diameter of the blade measured between the shank and the eye. Collectively, the type number and size number represent the complete symbol which is given on the label of all needles packed and sold by Union Special.

### TYPE

### DESCRIPTION

180 GYS Round shank, round point, lockstitch, short length ball eye single groove, struck groove, deep spot, chromium plated - sizes 075/029, 080/032, 090/036, 100/040, 125/049, 140, 054, 150/060.

180 GWS Round shank, round point, lockstitch, short length, oversize ball eye, single groove, struck groove, deep spot, chromium plated - sizes 090/036, 100/040, 110/044, 125/049, 140/054.

When changing the needle, make sure it is fully inserted in the needle holder before the screw is tightened.

When ordering needles, please use the complete type and size numbers as printed on the package to ensure prompt and accurate processing of your order. A complete order should read as follows: "100 needles, type 130 GS, size 125/049".



## TABLEBOARD

The tableboard can now be mounted on the pedestal using four screws, adjusting the nuts so the top of the tableboard is flush with the top of the machine bed plate.

## BOBBIN WINDER

The bobbin winder should be secured to the table top so that its pulley will be located directly in front of the sewing machine belt and will bear against the belt when in operation. The base of the winder has two elongated attaching holes, which allow the mechanism to be moved closer to or farther away from the belt as needed. The pulley of the winder, when in operation, should exert only enough pressure against the belt to wind the bobbin. Regulation and operation of the bobbin winder is described under "Winding The Bobbin", under "Instructions For Operator's".

## BELTS

These machines are equipped to use either #1 "Vee" or round belts.

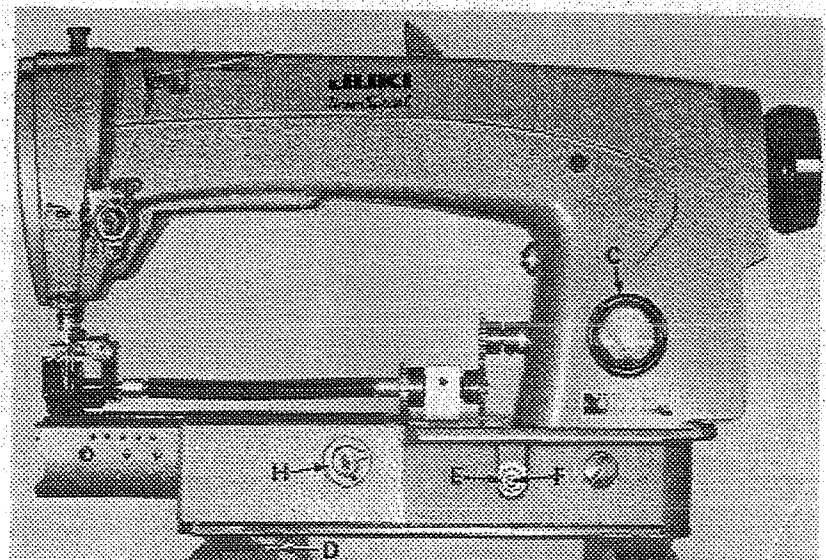
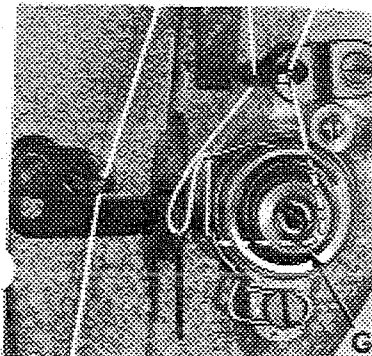
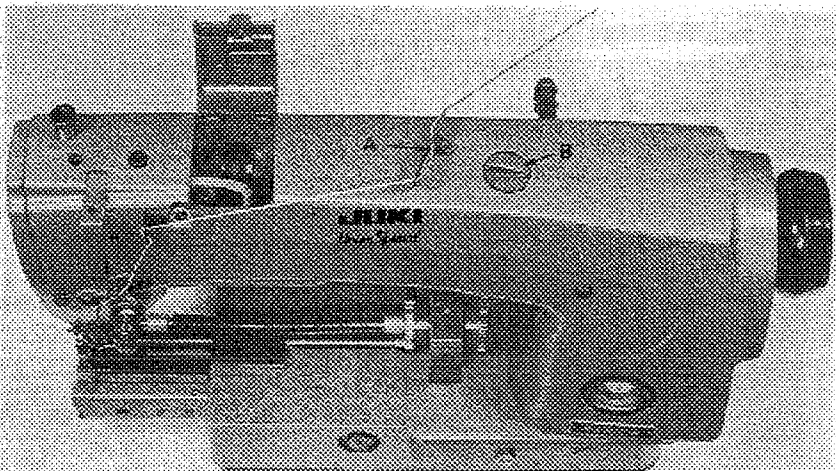

Fig. 3





## LUBRICATION

**CAUTION!** Oil has been drained from the main reservoir before shipment and the reservoir must be filled before starting to operate.

Lubricate machine thoroughly, in accordance with instructions which follow, and run slowly for several minutes to distribute the oil to the various parts. Full speed operation can then be expected without damage.

### RECOMMENDED OIL

Use a stainless water-white straight mineral oil of a Saybolt viscosity of 90 to 125 seconds at 100° Fahrenheit in the main reservoir. This is equivalent to Union special specification No. 175. Fill main reservoir at plug screw (B, Fig. 3) and check oil level at gauge (C): oil is at maximum level when needle is in yellow band marked "FULL". Oil should be added when needle is in yellow band marked "LOW".

It is recommended that a new machine, or one that has been out of service for an extended period, be lubricated as follows: Remove the head cover and directly oil the bearings of the needle bar link, the take-up and its lever and needle bar. Replace end cover, as no further hand oiling will be required.

Oil may be drained from main reservoir by removing plug screw (D, Fig. 3).

### OIL GAUGE

The oil gauge is set at the factory to show the proper oil level in the reservoir. Should an adjustment become necessary, the following steps should be followed:

1. Place the machine upright on a level table or bench.
2. Remove the reservoir plug screw (located below the handwheel and near the bottom of the machine).
3. Oil should be added or removed so that the oil level is approximately 1/8 inch below the bottom edge of the hole.
4. Loosen lock nut (E, Fig. 3) on the calibrating screw (F), and turn screw left or right so the gauge needle rests on the yellow band marked "FULL" on gauge (C).
5. Tighten lock nut and replace plug screw.



## SELF-PRIMING HEAD OIL SIPHON

Class 63900 machines are equipped with a self-priming head oil siphon. When the machine is started, oil splashes on the priming cup felt, filters through the felt and trickles down the vertical oil tube, thus priming the siphon. Once the prime is established, it is maintained, unless the felt is removed. The siphon operates twenty-four hours a day, removing oil at the rate of six to twelve drops per minute, which, of course, far exceeds the rate at which oil collects in the head.

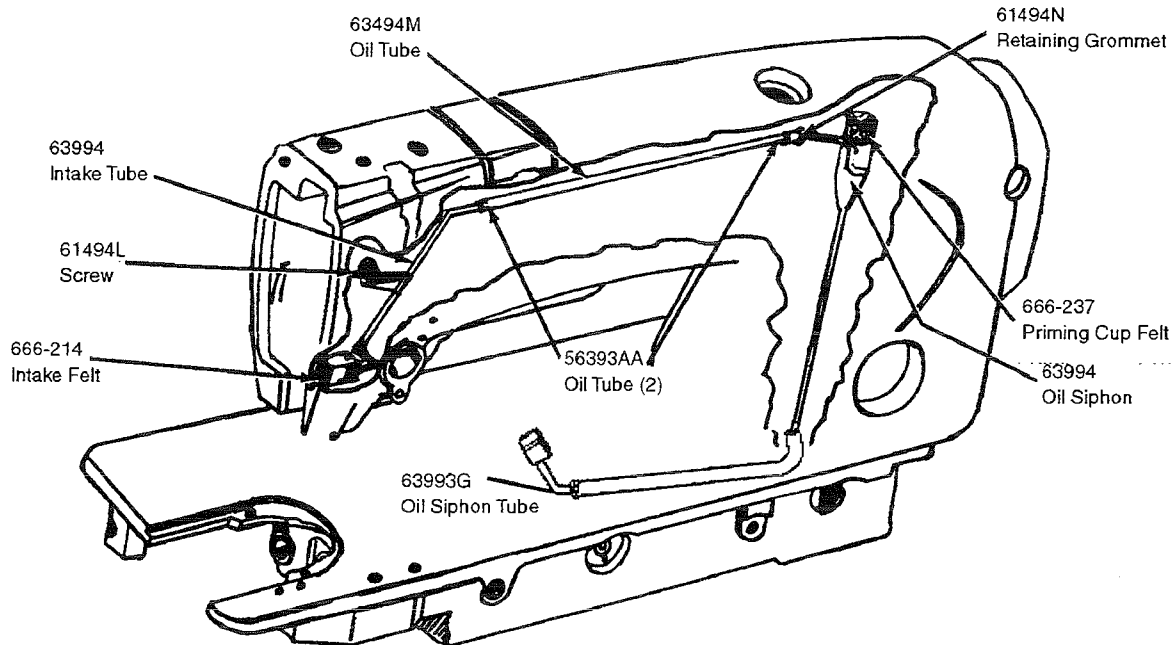

### INSTALLING AND MAINTENANCE OF OIL SIPHON

A newly installed siphon starts its action within three to five minutes after the machine is operating. However, it may be twenty minutes or so before all the air is removed from the line and the siphon is in full operation. Within an hour, there should be a distinct reduction of the oil in the head sump. If the siphon does not function, determine if the siphon intake tube, located in the head, is inserted in the felt block and that the plastic tube is connected at both ends. If the above two items do not correct the siphon, replace the siphon felts as described below.

The felt in the priming cup is designed for a specific purpose. This felt, No. 666-237, is to meter the flow of priming oil and to prevent the entrance of air. The felt also acts as a filter and keeps the siphon clear of lint.

If the priming cup felt and the intake felt (666-214) becomes contaminated with an excessive amount of lint, it may be necessary to replace the felts. The priming cup felt is replaced by removing access plug at back of machine and replacing felt 666-237. For the best initial self-priming condition, the felt of the siphon should be installed dry. The intake felt is replaced by removing the end cover.

However, if for some reason the priming cup felt has been oiled before installing, the siphon may fail because air is trapped in the felt. As a precaution, remove felt from cup. Then, while squeezing the felt between the fingers, saturate it well with oil. In other words, squeeze out the air and replace it with oil. This prevents the trapping of air, and no trouble should be experienced when starting the siphon.



## THREAD

While the direction of the twist in the bobbin thread is immaterial, the direction of the hook rotation favors the use of a left twist thread in the needle. To determine the direction of twist, grasp a short length of thread between thumb and forefinger of each hand. Turn the thread away from you with your right hand. If the strands unwind, it is a left twist, if not, it is a right twist.

### REMOVING THE BOBBIN CASE

To remove the bobbin case, turn handwheel in operating direction until needle reaches its highest position. Using the left hand, reach in under the throat plate at left end of machine, open the bobbin case latch (A, Fig. 5), and pull the bobbin case out of the sewing hook.

Opening the latch retains the bobbin in the case. When the latch is closed, the bobbin is released and can readily be removed.

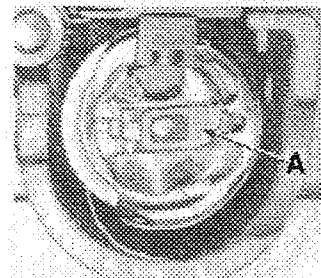

Fig. 5

### WINDING THE BOBBIN

Thread the bobbin winder by leading the thread from the supply down through the eyelet (A, Fig. 6), down between the tension discs, and under the tension post. Press an empty bobbin on the winder shaft (B), up to the stop, wind the end of thread around the bobbin a few turns in a clockwise direction and press downwardly on hand lever (D) until pulley is moved into contact with machine belt, and is locked in that position. When the machine is operated, the bobbin will be rotated and filled until the thread engages the automatic throw-out member, which disengages the pulley. The extent to which the bobbin is filled can be varied by regulating the screw (C).

The tension post bracket is mounted on the winder base, and can be shifted from left to right by loosening screw (E) so that any tendency of the bobbin to wind unevenly may be readily corrected.

The purpose of the bobbin winder is to assure an operator of a full bobbin at all times. When the bobbin in the machine is used up, replace it with the full one, and begin to wind the empty on immediately. Bobbins can be rewound while the machine is sewing.

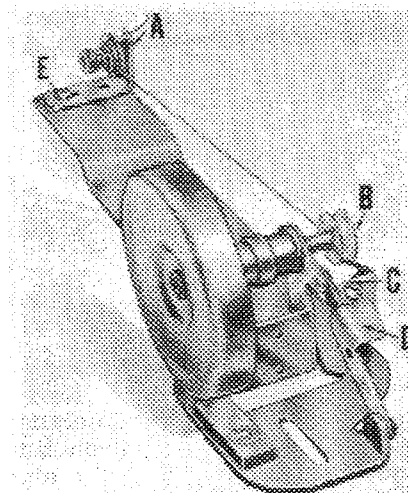

Fig. 6

### THREADING THE BOBBIN CASE

The bobbin case (A, Fig. 7) should be held between the thumb, forefinger and second finger of the LEFT hand.

The bobbin (B) itself should be held between the thumb and forefinger of the right hand with thread coming off the bottom of the bobbin.

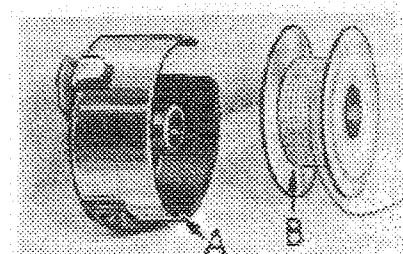

Fig. 7



## THREADING THE BOBBIN CASE (CONT.)

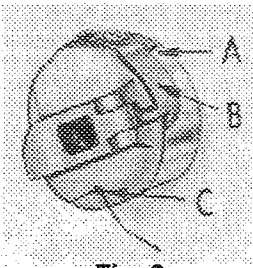

Fig. 8

Place the bobbin in the bobbin case. In one continuous motion, with thumb and forefinger of right hand, draw the bobbin thread through diagonal slot in bobbin case (A, Fig. 8) under the tension spring (B) and into self threading slot (C) on case. Note direction of the rotation of the bobbin as the end of the thread is pulled when looking at the bobbin case from the back. The bobbin should rotate counterclockwise.

## REPLACING THE BOBBIN CASE

Have the needle bar at its highest position, allow about two and one half inches of thread to hang free. The bobbin case latch should be opened with the left hand, and by reaching under the throat plate and through the bed plate extension, it should be placed part way into the sewing hook. The latch should then be released and bobbin case into position.

## INSERTING THE NEEDLE



Insert the needle into the needle bar as far as it will go, with the spot (sometimes called scarf) towards the right, facing the handwheel. Tighten the nut securely.

The cross hole in the needle bar, about 1/4 inch from the end (A, Fig. 9), is to show the operator when the needle has been inserted as far as it will go, and to provide a means for cleaning the accumulated lint from needle hole so the needle will seat properly.

## THREADING THE NEEDLE

Fig. 9

Threading diagram (Fig. 3) shows the places where the needle thread passes. Please note that the needle thread passes through the needle eye from left to right.

## PREPARATION FOR SEWING

With your left hand, hold the end of the needle thread, leaving it slack, and turn the handwheel in operating direction until the needle moves down and up again to its highest position. Pull up the needle thread and the bobbin thread will come up with it, through the needle hole in the throat plate. Draw both threads under the presser foot.

## TENSIONS

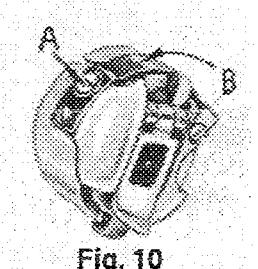

Fig. 10

A perfect stitch is one in which the needle thread and bobbin thread are locked together in the center of the material being sewn. A stitch of this kind is secured by regulating the tensions on both threads.

## BOBBIN THREAD TENSION

The tension on the bobbin case is applied by means of a set screw (A, Fig. 10) which regulates the tension spring (B). The tension on the spring is correct when it is just sufficient to hold the bobbin case and bobbin suspended by the bobbin thread. The thread should not be in the eyelet for this adjustment check.



## BOBBIN THREAD TENSION (CONT.)

Remove the bobbin case from its holder and turn set screw in spring in a clockwise direction to apply more tension or counterclockwise to release tension.

When the bobbin thread tension is correct, it rarely becomes necessary to make any changes as varying the needle thread tension will usually attain a good stitch.

## NEEDLE THREAD TENSION

The needle thread tension is varied by turning the tension regulating nut (G, Fig. 3). Turning the nut in a clockwise direction increases the tension, while counterclockwise decreases it. This should not be done when the presser foot is in its raised position, but is generally done while the machine is sewing on a piece of scrap material.

## CHANGING THE STITCH LENGTH

Unless otherwise specified machine Styles 63900AM, AML and AT will be equipped with upper feed regulator gear No. 63949-39 and lower feed regulator gear No. 63949-41 to produce 9 stitches per inch (S.P.I.), while Styles 63900AW, and AAE will be equipped with upper feed regulator gear No. 63949-37 and lower feed regulator gear No. 63949-43 to produce 10 S.P.I. Other gears are available and may be ordered separately. Refer to "Gear Chart" below for the gears necessary to produce S.P.I. other than previously described.

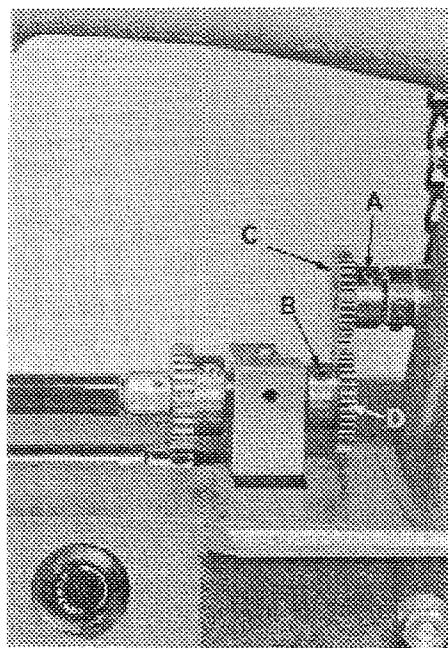

Fig. 11

### GEAR CHART

<u>S.P.I.</u>	<u>UPPER GEAR</u>	<u>LOWER GEAR</u>
6	63949-47	63949-33
7	63949-44	63949-36
8	63949-41	63949-39
9	63949-39	63949-41
10	63949-37	63949-43
11	63949-36	63949-44
12	63949-33	63949-47

To remove feed regulators gears, first remove feed drive gear cover located under arm of machine. Now loosen screws (A and B Fig. 11) and slide gears (C and D) off their respective shafts. Replace with gears for desired stitch length. After new gears have been installed be sure to reset needle feed stitch length to agree with the continuous turning roller feed.

## TIMING THE NEEDLE FEED WITH THE CONTINUOUS TURNING ROLLER FEED

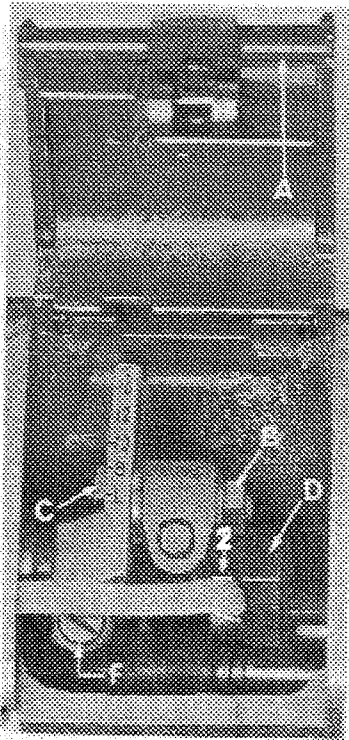

Fig. 12

Open top cover (A, Fig. 12) in the head of the machine and loosen needle frame drive segment locking nut (B). Set connection stud (C) to point of maximum number of stitches per inch of needle feed. This would locate the connecting arm at letter "S".

Loosen two set screws on the needle frame drive eccentric (D). Rotate the handwheel until the needle bar is at the bottom of its stroke. Rotate the eccentric only, until the timing line (2) on the connecting arm and the eccentric hub coincide. Tighten all screws, on every thick seams that cause thread breakage advance needle feed timing slightly.

Rotate handwheel until the needle bar is at bottom of its stroke. The needle bar should be vertical. If it is not, loosen clamp screw (F) and move needle bar frame forward and backward until bar is vertical. Tighten screw, making sure allside play is removed from between the needle bar frame and the segment.

To set needle feed with roller feed loosen needle frame drive segment locking nut. Set connection toward higher designated letter on segment for approximate setting. Vary the needle travel so as to obtain the least amount of needle deflection when the needle enters or leaves the thickest section to be sewn.

## PRESSURE ON MATERIAL

The presser spring (A, Fig. 17) should exert only enough pressure on the feed rollers to make the work feed uniformly. To increase the pressure on the presser foot, turn presser spring regulator (B, Fig. 17) in a clockwise direction.

Turning the regulator counterclockwise decreases the pressure.

## SETTING THE NEEDLE BAR TO HEIGHT

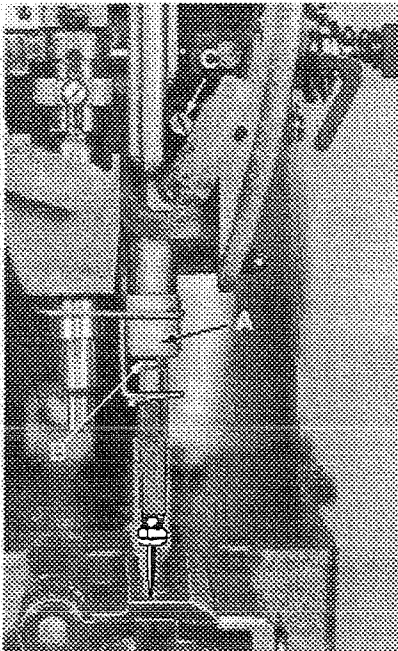

Fig. 13

The three lines engraved on the needle bar are used in setting needle bar to height, and are referred to as TIMING LINES.

The middle and lower lines are used for Styles 63900M, T, and W. For 63900AM, AML, AAE, AT and AW the upper and middle lines are used.

When the needle bar is at its lowest position the upper timing line (B, Fig. 13) should be EVEN with the lower edge of the lower needle bar frame (A).

To change the position of the needle bar, turn handwheel until the bar is at its lowest position. Then, loosen the clamp screw (C) and move the bar to the proper timing line. Keeping the needle bar line at its lowest position, tighten the screw securely.



## TIMING THE HOOK

Remove throat plate. Loosen three set screws (A) in the hook, and hold the hook and the bobbin case holder in such a position as to prevent interference with the needle. Turn handwheel in operating direction until the needle bar is at its lowest position, and continue to turn the handwheel until the needle is ascending and the middle timing mark (Fig. 13) used in setting the needle bar is even with the lower edge of the needle bar frame (A).

Turn the hook on the shaft until the point of the hook is even with the center of the needle and as close to the needle as possible without deflecting it. A spacing of .003 to .005 inch between the needle and the point of the hook is satisfactory. With the hook in this position, tighten the set screw opposite the hook point securely. Then, tighten the two remaining screws securely, and recheck the timing of the hook with the needle. At the hook timing position the top of the eye of the needle should be about 1/64 inch below the bottom of the hook point.

Replace throat plate, allowing 1/32 inch clearance between the outside edge of projection and the inside edge of bobbin case recess.

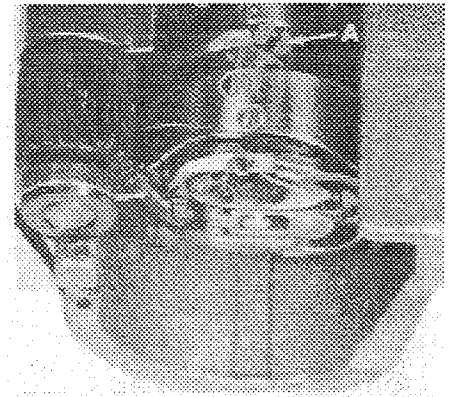

Fig. 14

## NEEDLE GUARD INSTRUCTIONS

In the hook, at the right side of the needle hole in bobbin case holder (B, Fig. 15) is found a needle guarding surface (A, Fig. 15).

The purpose of this guarding surface is to prevent the hook point (C) from coming in contact with needle (D) at loop-taking time, should the needle be deflected toward the hook point. The needle guard will deflect the needle slightly when needle is at bottom of its vertical travel if the hook is properly timed. (At loop-taking time there should be little or no deflection of needle by the needle guard.)

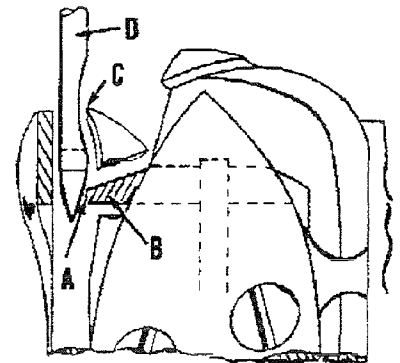

Fig. 15

For additional needle clearance, especially with use of larger needles, removal of some needle guarding surface may be necessary.

Before metal removal from the guarding surface all related settings should be checked as follows:

1. See that the needle bar is set to correct height.
2. Check for proper hook timing.
3. Rotate the handwheel in operating direction by hand. Check for excessive needle deflection beyond what is cited on preceding page as a desirable condition.
4. If needle deflection is excessive, follow steps (A) and (B) below.

(A) Remove bobbin case holder from hook.

(B) Remove excess metal from the needle guarding surface. This may be done by using a diamond file No. TT60 or fine emery cloth (#320), with one end secured to the bench, and rubbing the guarding surface back and forth until sufficient metal is removed. When metal is being removed from needle guarding surface, the bobbin case holder should be reinserted frequently and tested until proper needle guarding is obtained.

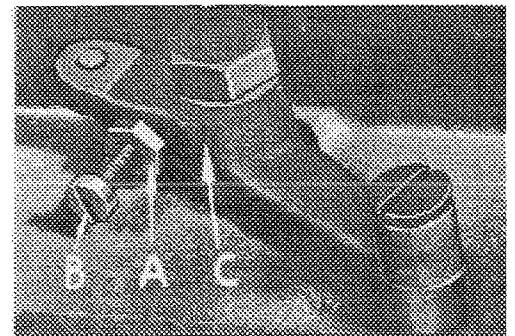

Fig. 16

## NEEDLE GUARD INSTRUCTIONS (CONT.)

**CAUTION!** Damage to the hook point may result if too much metal is removed from the needle guarding surface.

The bobbin case holder should be thoroughly cleaned before reassembly into the hook base.

When altering needle guarding surface, it is suggested that the hook NOT BE REMOVED or disturbed from its timed position.

The bobbin case holder only may be removed by removing gib screws and gib and pulling on bobbin case stem as the handwheel is rocked backward and forward slightly.

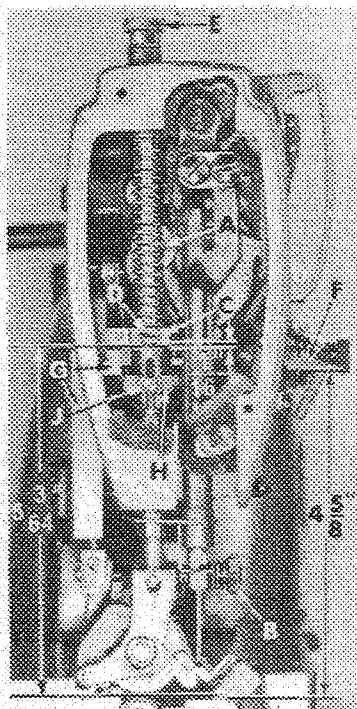

Fig. 17

feed roller by turning regulator (E) clockwise.

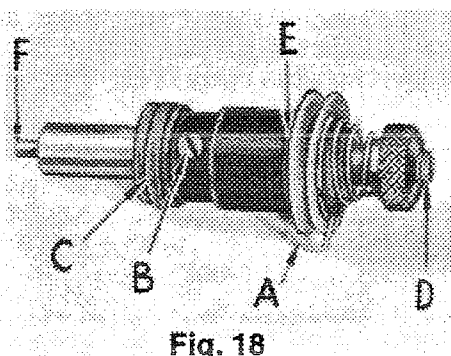

Fig. 18

## HOOK LUBRICATION

**CAUTION!** Do not run the machine without the bobbin case in the hook as hook damage may result.

With the bobbin case in hook, run machine for a full minute. Place a piece of white paper directly under the hook and continue running the machine. After about five seconds, remove the paper and a definite and distinct pattern of oil spots should be observed.

Should more or less oil be required, turn oil control adjusting shaft (H, Fig. 3), located on the front of the machine just below the cloth plate surface, in direction of the change required. After a change in the hook oil flow, the machine should be run about one minute before checking for the desired oil flow.

## PRESSER BAR GUIDE

When locating presser bar guide (C, Fig. 17) presser foot must rest directly against throat plate. Proper setting of guide is  $5 \frac{3}{64}$  inches between underside of presser bar guide and the top of throat plate (Fig. 17). To obtain this setting, remove pressure from the presser spring (A) and loosen set screw (D). Tap on presser foot to insure it is down against throat plate. Set guide to the  $5 \frac{3}{64}$  inch dimension, center foot by turning it so needle enters the middle of its slot and retighten screw (D). Apply pressure to top

Set needle thread pull-up bracket (F) so that underside of wire is  $4 \frac{5}{8}$  inches above throat plate (Fig. 17).

## PRESSER BAR CONNECTION

Presser bar connection (G, Fig. 17) should be set about  $\frac{1}{16}$  inch below presser bar guide (C). Accomplish this by loosening lock nut (A, Fig. 16), and relocating stop screw (B) on lifter lever bell crank (C), located at the back of machine, under bed plate. Turning stop screw to right or left, properly sets presser bar connection. Tighten lock nut (A) to lock stop screw.



## TENSION ASSEMBLY ADJUSTMENT

Test check spring tension (A, Fig. 18). There should be enough tension to assure a good returning snap when the spring is depressed and released. Should it require adjusting, loosen set screw in head located under arm and to the right of tension assembly and remove tension assembly. Partially loosen tension post set screw (B) in tension post socket (C). Turn tension post (D) counterclockwise until check spring moves away from upper stop (E) and has no tension on it. Turn tension post (D) in a clockwise direction until spring again touches upper stop (E). Proceed further in same direction approximately 1/4 turn until desired tension is obtained. When correctly set, tension post set screw (B) should be drawn up snugly, yet not forcefully. Further adjustment of check spring tension can be made by inserting a screwdriver into slotted end of tension post (D) and turning in required direction.

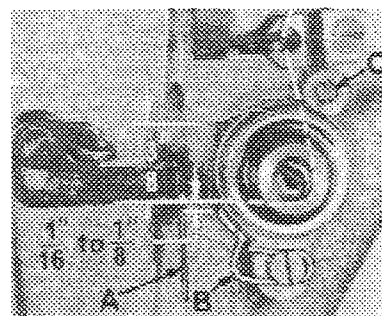

Fig. 19

Replace tension assembly with check spring about 3/8 inch above thread take-up bracket (A, Fig. 19). Replace tension post assembly while presser foot is resting on throat plate.

## TENSION RELEASE

Tension release should be set so as not release when sewing over seams or when presser foot is raised. Adjustment of tension release cam (H, Fig. 17) and in and out position of tension assembly are required for proper operation.

The in and out position of the tension assembly is correct when the tension discs are in line with the check spring eyelet (B, Fig. 19). Set the stop screw (C, Fig. 19) so that when the flange of the tension assembly rests against it, this position is maintained. Tighten the tension assembly set screw.

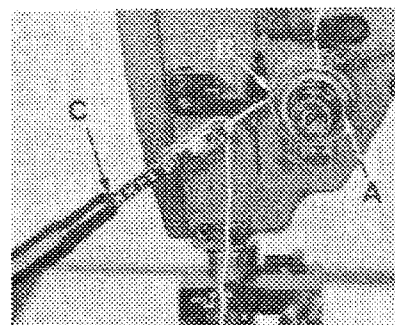

Fig. 20

The tension release cam (H, Fig. 17) should now be positioned by loosening set screw (J) and then rising or lowering cam (H) to suit the sewing conditions. The average release point is between 1/4 and 5/16 inch of presser foot lift above the throat plate. Tighten tension release cam set screw securely.

## THREAD CONTROL

Check the adjustment of tension assembly (A, Fig. 20) and check spring tension. There should be enough tension to insure a good returning snap when spring (B, Fig. 20) is depressed and released. The check spring tension is adjusted from about 1 to 1 1/4 ounces when measured with a postal scale, No. 21227DN, (C, Fig. 20). This is measured when the check is 1/32 to 1/16 inch from the stop. The tension post set screw should be drawn up snugly but not forcefully tightened (B, Fig. 18). The tension release pin should move freely in the tension post (D, Fig. 18). The check spring eyelet (B, Fig. 19), located just below the tension discs, should be set for correct height as follows:

With a thread running from the tension post to the thread take-up bracket (A, Fig. 19) in a straight line, the check spring eyelet should be set 1/16 to 1/8 inch below the thread line (Fig. 19). Be sure the eyelet is set close to the tension discs so that the check spring will pass freely over it without obstruction. After making this setting, proceed to thread machine as per threading diagram (Fig. 3).

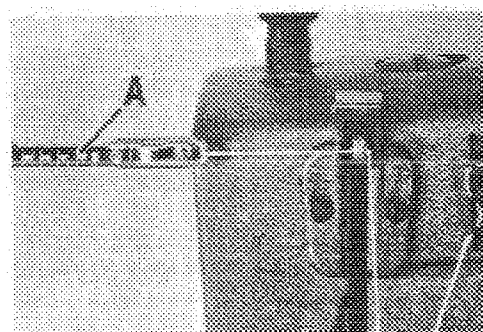

Fig. 21

## THREAD CONTROL (CONT.)

Sew slowly on a piece of material and observe the action of the check spring. The thread from the check spring to the take-up bracket should be taut when the take-up is at the bottom of its stroke. Slight changes in needle thread tension may be necessary at this point, but a reasonable tension should be used to maintain a uniform and consistent stitch. The machines are sewn off with 4 to 8 ounces maximum needle thread tension on T120 or similar thread, using a postal scale (A, Fig. 21). Depress check spring when checking tension. The check spring will feel heavy to you, but this is a required setting for Class 63900, and as a result, the tension on the discs can be reduced.

## BOTTOM COVER

Before removing bottom cover, place machine on bench so that the plug screw is accessible from underneath. Remove this plug screw and catch reservoir oil in some convenient container. Tip machine back, loosen and remove the two cover screws. Cover should be tapped free with a wooden block or mallet. Do not pry the cover loose with any sharp instrument as the gasket may become damaged.

**CAUTION!** When the bottom cover is removed, care should be taken not to mar or scratch the gasket seat area of the machine bottom.

Before replacing cover, the machine gasket seat should be wiped clean and free of all lint and dirt. The cover gasket should also be inspected for damage and cleaned of dirt. Two additional gaskets are used to seal the bolts and must be cleaned before assembly. Carefully set the cover in place and tighten the two bolts securely.

To replace a damaged cover gasket, proceed as follows:

1. Clean cover gasket recess of any foreign matter.
2. The gasket in cross section is triangular in shape with a groove in the top or widest part. With the cover resting as it does in the machine, oil distributing plate to your right, begin inserting in the middle of the back recess. The grooved wide edge of the gasket should be up and the ling sloped edge inward. Continue pressing the gasket into the cover recess until gasket is in place.

The bolt sealing gaskets may have a tendency to fall out when the cover is being installed and may be temporarily cemented in place by applying grease to their recesses. Torque to 72 inch lbs.

## HOOK SHAFT

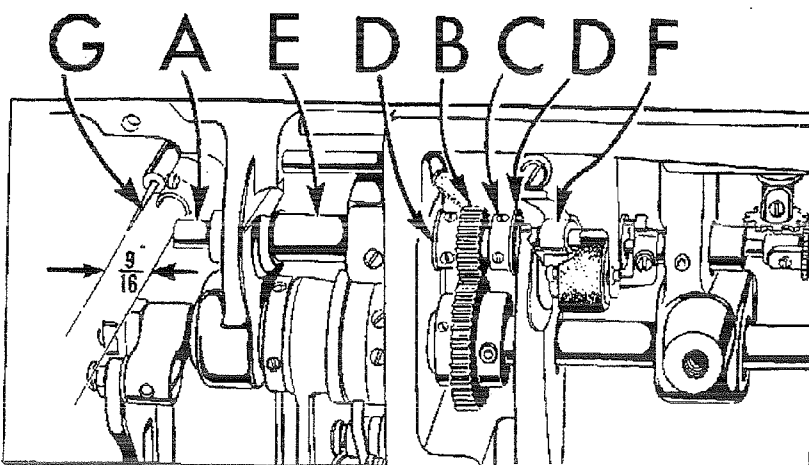

Fig. 22

The hook shaft (A, Fig. 22) is held in position by the pinion (B) and collar (C) thrusting against hard steel washers (D) between the long left hand bushing (E) and the short right hand bushing (F).

Should hook shaft setting be disturbed, the left and right position can be determined by measuring from the hook end of the hook shaft to the point of a new needle (G) and reading  $9/16$  inch on a scale.



## HOOK SHAFT (CONT.)

To reposition the hook shaft, loosen the set screws of the pinion and collar and establish the 9/16 inch dimension. Move the pinion and thrust washer against the left bushing, and after making certain one of the set screws in on the shaft **FLAT**, tighten both screws securely. Liberally coat the collar and its washer with oil and press the collar away from the pinion so as to remove all end play and tighten both set screws securely.

Hook oiling is accomplished by a high speed rotary pump on the end of the hook shaft. The quantity of oil supplied to the hook is regulated by the longer or shorter path the oil is required to travel through the metering felt of metering cup (G, Fig. 23). (Increase or decrease of oil supply is controlled by a dial (P, Fig. 23) with an arrow marked "INCREASE", found below the cloth plate.) The hook oil feed roller (A, Fig. 23) which rests against the metering cup felt serves not only to feed oil to the unit from the oil reservoir, but filters the oil as well.

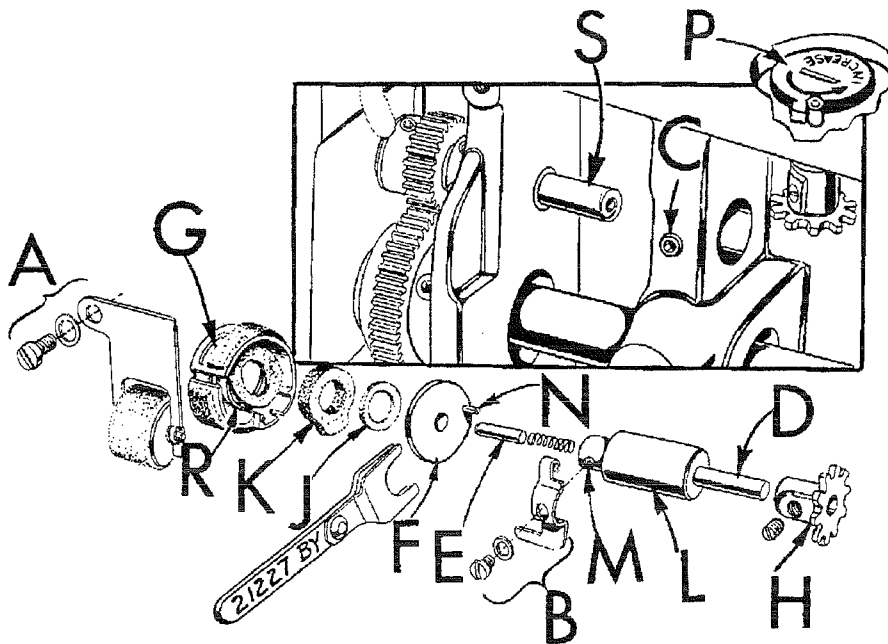

Fig. 23

### REMOVAL OF OILING DEVICE

The following steps are necessary to remove hook oiling device:

1. Remove hook oil feed roller (A, Fig. 23).
2. Remove hook oil control finger (B).
3. Apply finger pressure to hook oil control shaft (D) to prevent loss pump disc pivot pin (E); using Allen wrench, loosen set screw (C). Move assembly slowly to right, being careful not to drop pivot pin located on the end of the hook oil control shaft. When pivot pin is clear of pump disc (F), disc is free to fall.
4. Remove metering cup (G) along with oil supply felt (K) and air seal felt (J).
5. Remove cop (H) from hook oil control shaft.

## REASSEMBLY OF OILING DEVICE

Before reassembly, the end of the hook shaft, its spiral groove and the pump disc should be thoroughly cleaned. Remove any end play found in the hook shaft and determine that the 35/64 inch dimension has been maintained (Fig. 22).

The following steps are necessary to reassemble the hook oiling device:

1. Remove and separate the air seal felt (J, fig. 23) from oil supply felt (K).
2. Make sure small end of air seal spring (R) is located on boss of metering cup behind felt attached to cup. Position the metering cup (G) and air seal spring on the hook shaft (S) with open end toward handwheel end of the machine (Fig. 23).

NOTE: The hook shaft should pass through hole of felt attached to metering cup.

3. Position oil supply felt (K, Fig. 23) on the hook shaft, making certain the felt's projection extends into dovetail of metering cup.
4. Position air seal felt (J) on hook shaft.

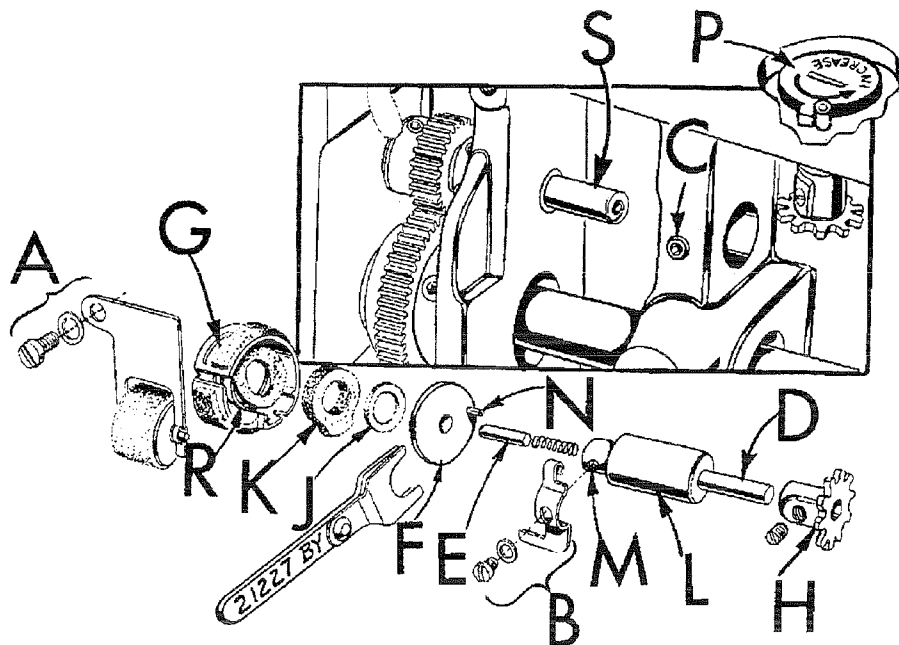

Fig. 23

5. Insert pump disc (F) into assembly tool No. 21227BY, with the stop pin on the spring side of tool, 180° from handle. Insert disc approximately half way into the spring and center in tool (Fig. 25).
6. Insert hook oil control shaft (D, fig. 23) and its bushing (L) part way into its boss which is located directly behind the hook shaft, being careful NOT TO DROP the pump disc pivot pin (E).

## REASSEMBLY OF OILING DEVICE (CONT.)

7. A clearance cut on the edge of the metering cup, located between the dovetail and the long horizontal slot, has been provided for the pump disc tool and should be facing you (Fig. 25).
8. With the fork of the tool in line with the metering cup clearance cut and centered about the hook shaft end, press felts to the left with tool until the pump disc is in contact with end of the hook shaft.

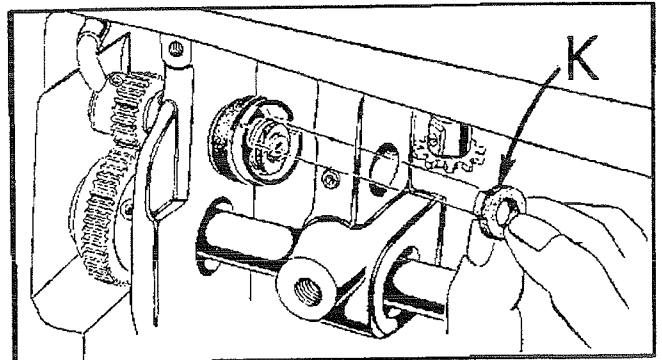

Fig. 24

9. Press hook oil control shaft bushing (L) to the left until control shaft (D) is approximately 1/16 inch away from pump disc (F). Make sure the control shaft pivot pin (E) seats in the depression at the center of the pump disc. Tighten set screw (C, Fig. 25) and withdraw assembly tool. Be sure sir seal felt (J) has seated against the pump disc.
10. Turn the hook oil control shaft (D, Fig. 26) until screw hole (M) is accessible. Manually rotate pump disc (F) so its stop pin (N) is 90° above screw hole.
11. Rotate metering cup so the short slot (T) is 180° from stop pin (N). Now, install hook oil control finger (B) by first hanging the hooked portion of finger over the stop pin and lowering to insert the projection at bottom left into the short slot of the metering cup. Tighten the finger in place by means of screw and washer, making sure the hook oil control finger does not bind or distort metering cup.

12. Assemble the hook oil feed roller (A, Fig. 27), and rotate the metering cup so that the roller contacts the metering cup felt at point (U, Fig. 27). Turn the oil control adjusting shaft (P, Fig. 27) in the increase direction until projection stops against the stop in (this is maximum oil supply) and install the cog (H, Fig. 27) on the hook oil control shaft. After meshing the teeth, tighten set screw securely.

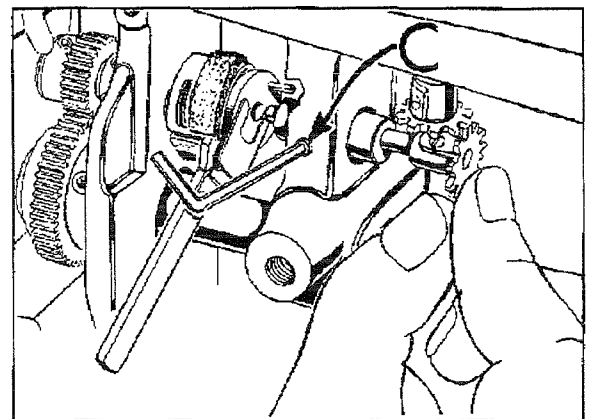

Fig. 25

13. Check for proper contact of the hook oil feed roller and the metering cup by turning the oil control adjusting shaft through its complete travel and observe the feed roller turning as the metering cup turns. With the oil control adjusting shaft set at maximum, the feed roller point of contact with the metering cup felt should be at the mid-point of the slot that permits the metering cup felt to enter the metering cup.

NOTE: The feed roller should be in contact with the metering cup felt through its complete travel.

## UPPER MAIN SHAFT

In a high speed machine, the alignment of the take-up mechanism is extremely important and is controlled by the left and right position of the upper main shaft. Should the main shaft position be altered, it is imperative that the take-up alignment be checked before operating.

## UPPER MAIN SHAFT (CONT.)

### TO CHECK FOR ALIGNMENT

1. Remove the presser bar spring, washer and regulator screw.

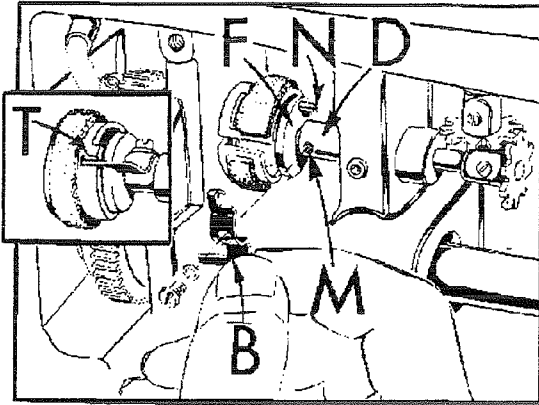

Fig. 26

Insert the oil wick about 1/2 inch in the bore of the take-up lever. With the oil groove up, insert the take-up lever pin in the lever, making sure the wick is in the groove and press the pin into its hole in the arm. There should be no end play in the take-up lever after the set screw is securely tightened. Replace the plastic plug.

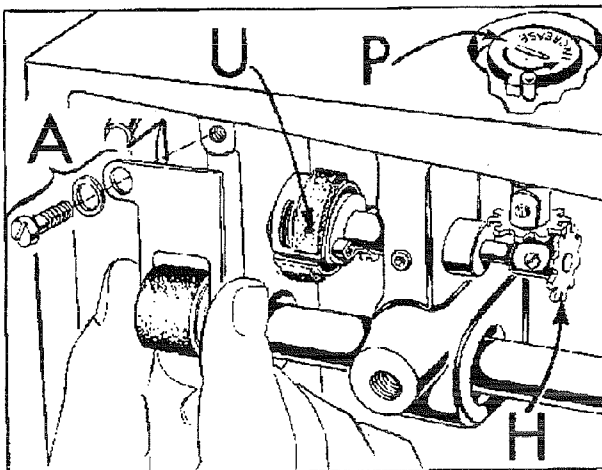

Fig. 27

2. Rotate the handwheel so that the needle bar is at the bottom of its stroke. Loosen hexagonal head screw on back of the presser bar roller bracket, and set screw on left side of roller bracket. Then loosen screw on presser bar guide and remove presser bar, presser bar spring washer and presser bar guide.
3. Remove the upper left plastic plug on the back of the machine and loosen screw in plug hole. Remove take-up lever pin. With light inward finger pressure, move the take-up lever to the take-up lever boss. There should be a small amount of interference between the lever and the boss. With light outward finger pressure, move the lever across the boss face. There should be clearance between the boss face and lever. These two tests, in effect, are checking the lateral play of the take-up and provide for operation of the take-up in the center of the lateral play. Now, line up the take-up lever hole in the lever boss.

Replace presser bar guide and presser bar spring washer into position. Place presser bar into presser bar roller bracket with flat on bar to the rear and tighten hex head screw and set screw securely.

Line up needle hole in the presser foot with the needle and tighten presser bar guide screw.

Assemble presser spring, presser spring washer and presser spring regulator screw.

Refer to paragraph on "Presser Bar Guide" for proper setting of the guide.

Should the alignment test show the main shaft is out of position, the upper sprocket and handwheel should be loosened and the shaft moved left or right as the conditions indicate. Retighten sprocket and handwheel so that there is no end play in the upper main shaft and

repeat the alignment check.

## HANDWHEEL

The handwheel is constructed so as to minimize noise and is therefore isolated from the pulley by shock mounts. If for any reason the handwheel is disassembled, the following steps should be used for reassembly.



## HANDWHEEL (CONT.)

1. Using the upper main shaft as a mandrel, assemble the pulley thrust face down so that at least 1 1/2 inches of the shaft protrudes above it. Tighten the two set screws.
2. Place the rubber isolator ring on the pulley face and align holes.
3. Carefully slide handwheel down the shaft to contact the isolator and align the three holes.
4. Three plastic "O" rings are now inserted into their respective holes in the handwheel.
5. The outer isolator rings and cap are assembled.
6. Insert the three screws that are run through the complete assembly and tighten lightly.
7. Loosen the two pulley screws and slowly revolve the whole assembly several times for good alignment. Now, gradually tighten the three screws, moving from one to the other until all are snug.
8. The assembly should run true as it revolves freely on the shaft. If any sidewise run-out is noted, it can be corrected by slight changes of screw pressure in the three isolator screws.

**CAUTION!** When replacing the handwheel assembly on the main shaft, care must be taken not to damage the oil seal located near the end of the shaft. The surface of the ring should be lightly oiled and the handwheel worked over the seal gently.

## ATTACHMENTS

Style 63900AM, AML is equipped with a retractable hemmer (A, Fig. 28) which produces 3/8 to 1/2 inch width of hem. To adjust to desired width loosen two screws (B & C) and slide hemmer scroll (D) to the right or left.

To change the sewing margin loosen screws (E & F) and slide the hemmer (A) to the right or left to obtain desired margin.

Style 63900AT is equipped with an adjustable edge guide for producing margins from 1/2 to 2 1/2 inches wide. For margins wider than 1 5/16 inches the base of the edge guide must be reversed.

To change margin relocate edge guide in holes provided until desired margin is obtained.

Style 63900AAE, AW is equipped with a cloth plate extension to provide a platform for guiding trousers. It is easily attached to the machine by three No. 22517B screws.

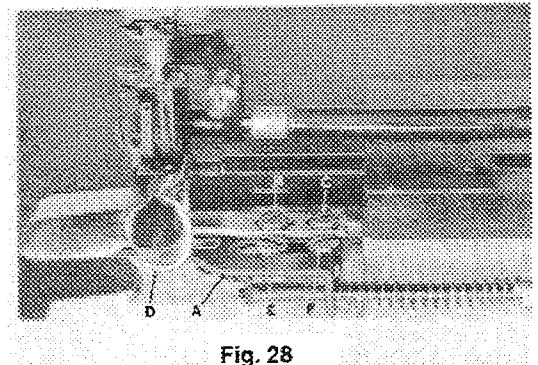
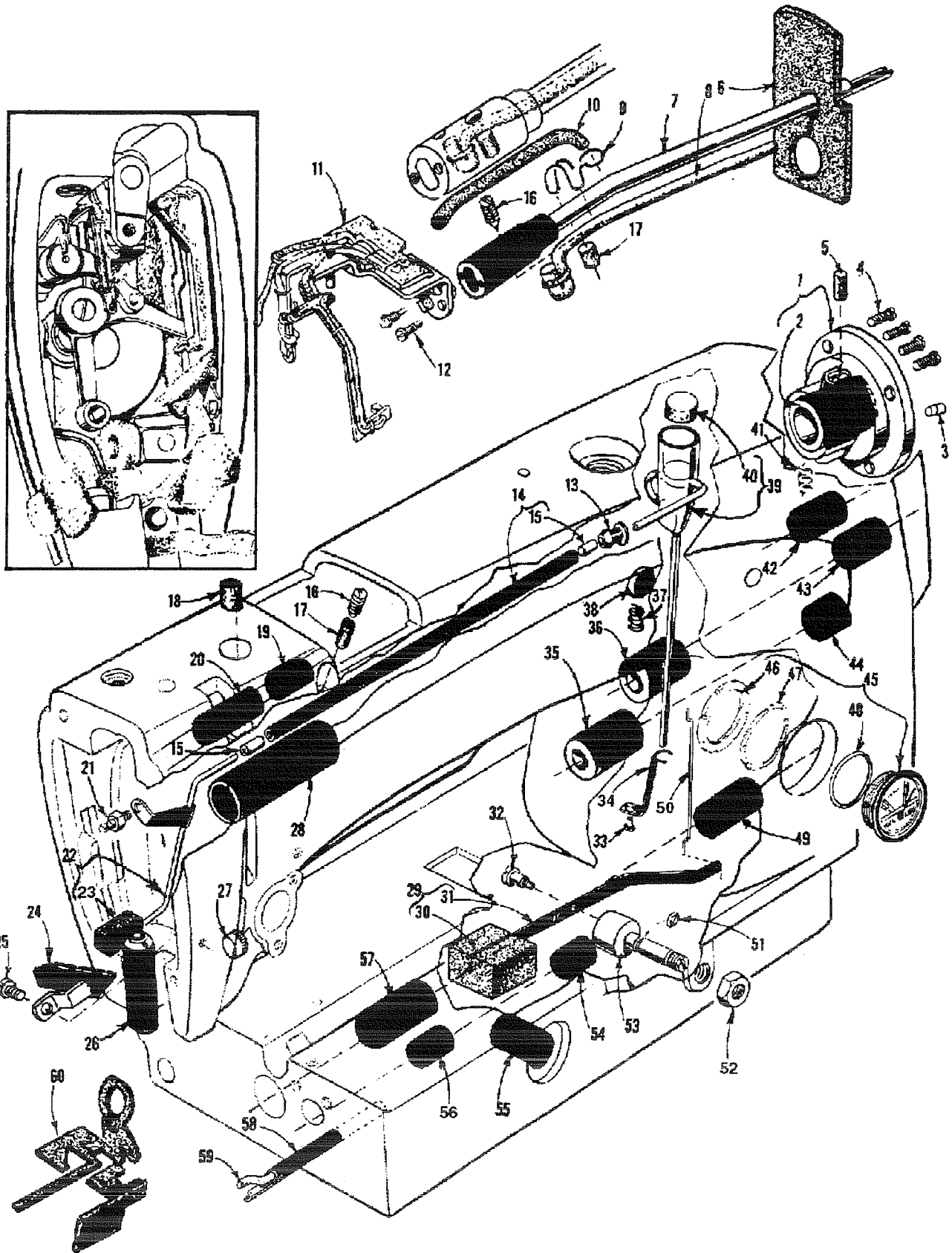

Fig. 28

## NEEDLE HOLE INSERT (SEE PAGE 44)

The throat plate has a replaceable needle hole insert. To remove this insert, drive it out from the underside of the throat plate.





**MAINFRAME, BUSHING, OIL GAUGE HEAD OIL SIPHON AND  
MISCELLANEOUS OILING PARTS**

Ref. No.	Part No.	Description	Amt. Req.
1.	61490B	Main Shaft Bushing Housing, including bushing .....	1
2.	61490C	Bushing .....	1
3.	63949R	Plug, for bed .....	1
4.	22569B	Screw .....	4
5.	666-200	Oil Felt .....	1
6.	666-254	Felt Baffle .....	1
7.	63993D	Head Oil Supply Line .....	1
8.	666-225	Felt .....	1
9.	63984C	Spring Clip .....	1
10.	666-223	Roll Felt .....	1
11.	63993C	Head Oiler Assembly .....	1
12.	22784K	Screw .....	2
13.	61494N	Retaining Grommet .....	1
14.	63494M	Oil Siphon Connecting Tube .....	1
15.	56393AA	Oil Tube .....	2
16.	22815	Plug Screw .....	1
17.	666-224	Roll Felt .....	1
18.	666-228	Oil Felt .....	1
19.	61985H	Needle Bar Frame Rocker Shaft Bushing, right .....	1
20.	61985G	Needle Bar Frame Rocker Shaft Bushing, left .....	1
21.	61494L	Stud .....	1
22.	63994	Oil Siphon Head Tube .....	1
23.	666-214	Oil Felt .....	1
24.	63953A	Oil Shield .....	1
25.	22564	Screw .....	1
26.	63957A	Presser Bar Bushing, lower .....	1
27.	51-159BLK	Plug .....	1
28.	61490D	Upper Main Shaft Bushing, left .....	1
29.	63494C	Oil Gauge Float Assembly .....	1
30.	61494D	Oil Gauge Float .....	1
31.	61494E	Oil Gauge Float Lever .....	1

32. thru 60. see following page.



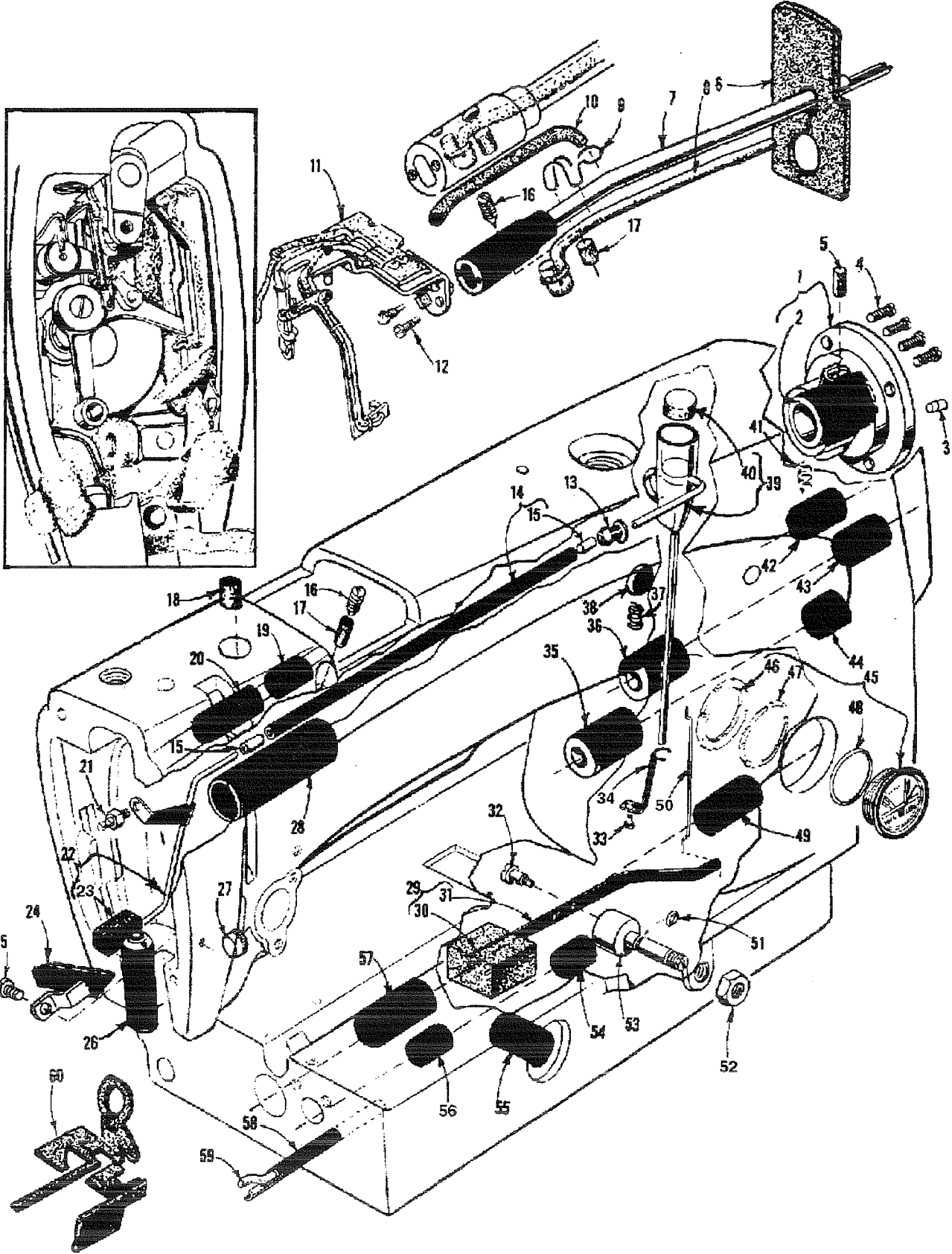

**MAINFRAME, BUSHING, OIL GAUGE HEAD OIL SIPHON AND  
MISCELLANEOUS OILING PARTS (CONT.)**

Ref. No.	Part No.	Description	Amt. Req.
1. thru 31. see preceding page.			
32.	22890C	Screw .....	1
33.	22564	Screw .....	1
34.	63993H	Oil Siphon Primer Position Bracket .....	1
35.	63962D	Lower Reduction Gear Shaft Bushing, left .....	1
36.	63962G	Upper Reduction Gear Shaft Bushing, left .....	1
37.	666-238	Bed Oil Drain Hole Felt .....	1
38.	61293N	Bed Plug .....	1
39.	63494D	Oil Siphon Priming Cup .....	1
40.	666-237	Cup Felt .....	1
41.	666-221	Oil Wick, for bushing housing .....	1
42.	63962E	Middle Reduction Gear Stud Bushing .....	1
43.	63962F	Upper Reduction Gear Shaft Bushing, right .....	1
44.	63962C	Lower Reduction Gear Shaft Bushing, right .....	1
45.	63494K	Oil Gauge Assembly .....	1
46.	63494F	Nut .....	1
47.	63494G	Spring Washer .....	1
48.	660-455	"O" Ring .....	1
49.	61432B	Hook Drive Shaft Bushing, right .....	1
50.	61494H	Oil Gauge Connecting Link .....	1
51.	660-221	"O" Ring .....	1
52.	11635B	Nut .....	1
53.	61494T	Float Lever Pivot Stud .....	1
54.	61496P	Hook Oil Control Shaft Bushing .....	1
55.	61496S	Hook Oiling Control Adjusting Bushing .....	1
56.	61441A	Hook Shaft Bushing, right .....	1
57.	63432C	Hook Drive Shaft Bushing, left .....	1
58.	63993B	Hook Shaft Bushing Oil Tube .....	1
59.	666-239	Oil Wick .....	1
60.	666-234	Head Oil Attraction Felt .....	1
-	63490B	Gasket (not shown) .....	1



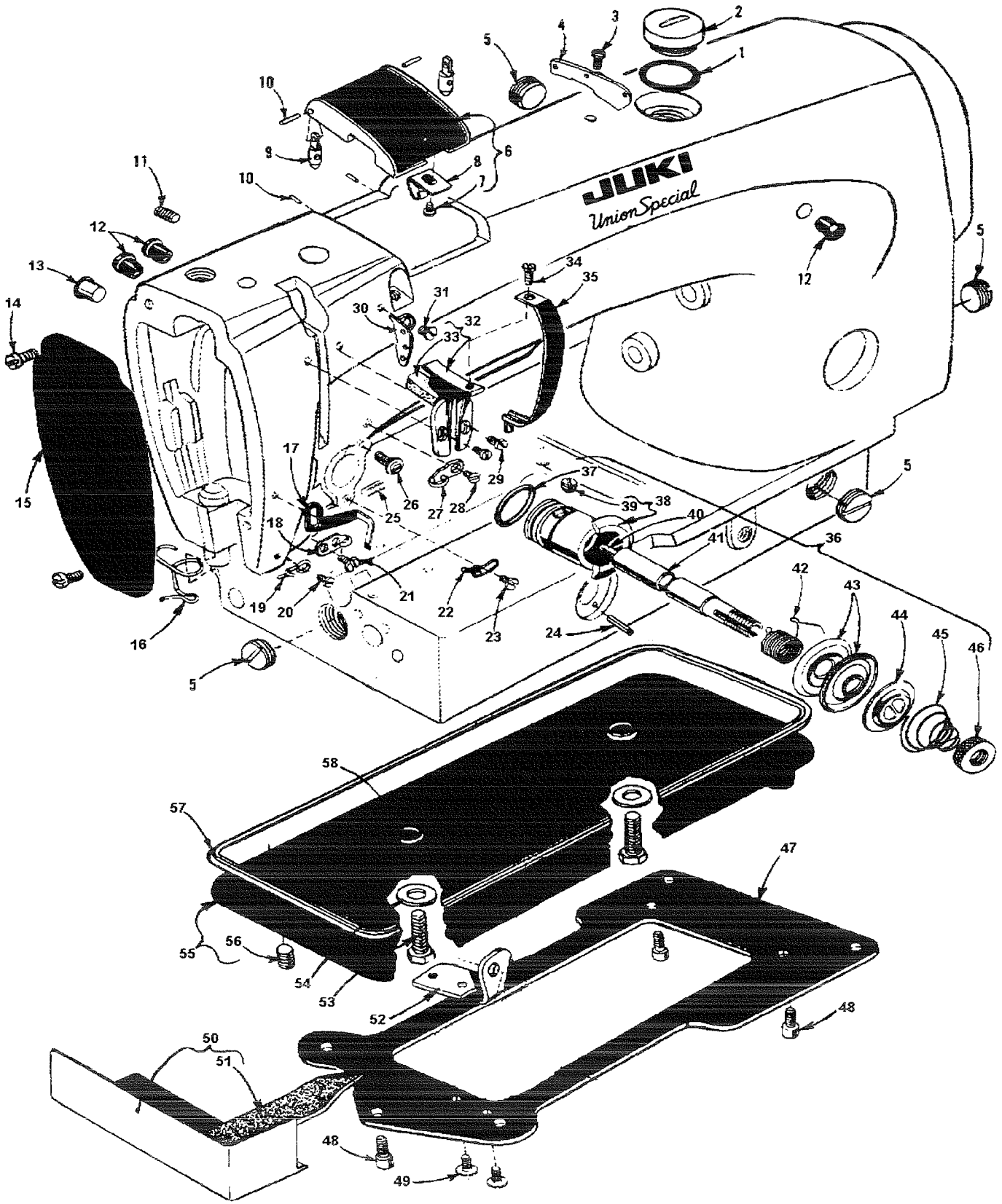

## MAIN FRAME MISCELLANEOUS COVERS AND NEEDLE TENSION PARTS

Ref. No.	Part No.	Description	Amt. Req.
1.	63494A	Gasket .....	1
2.	22733D	Plug Screw, for oil filler hole .....	1
3.	22570A	Screw .....	1
4.	61470D	Frame Thread Eyelet .....	1
5.	22539P	Plug Screw .....	4
6.	63982A	Top Cover .....	1
7.	22513D	Screw .....	1
8.	63982F	Spring Clip .....	1
9.	61982C	Top Cover Hinge .....	2
10.	61982D	Top Cover Hinge Pin .....	4
11.	22894E	Screw .....	1
12.	63994C	Plug, plastic, overall length 7/16 inch (11.1mm) .....	6
13.	660-409	Tension Release Bushing Plug .....	1
14.	22516	Screw .....	2
15.	63982	Head Cover .....	1
16.	63970B	Needle Bar Bushing Thread Guide .....	1
17.	63970A	Thread Pull-up Bracket .....	1
18.	63470A	Upper Needle Thread Eyelet .....	1
19.	63470	Lower Needle Thread Eyelet .....	1
20.	90	Screw .....	1
21.	22766	Screw .....	1
22.	63492	Tension Post Eyelet .....	1
23.	HS24C	Screw .....	1
24.	660-219A	Roll Pin .....	1
25.	22597E	Set Screw, for tension assembly .....	1
26.	22863B	Stop Screw, for tension assembly .....	1
27.	61470C	Thread Guide .....	1
28.	22766	Screw .....	1

29. thru 58. see following page.



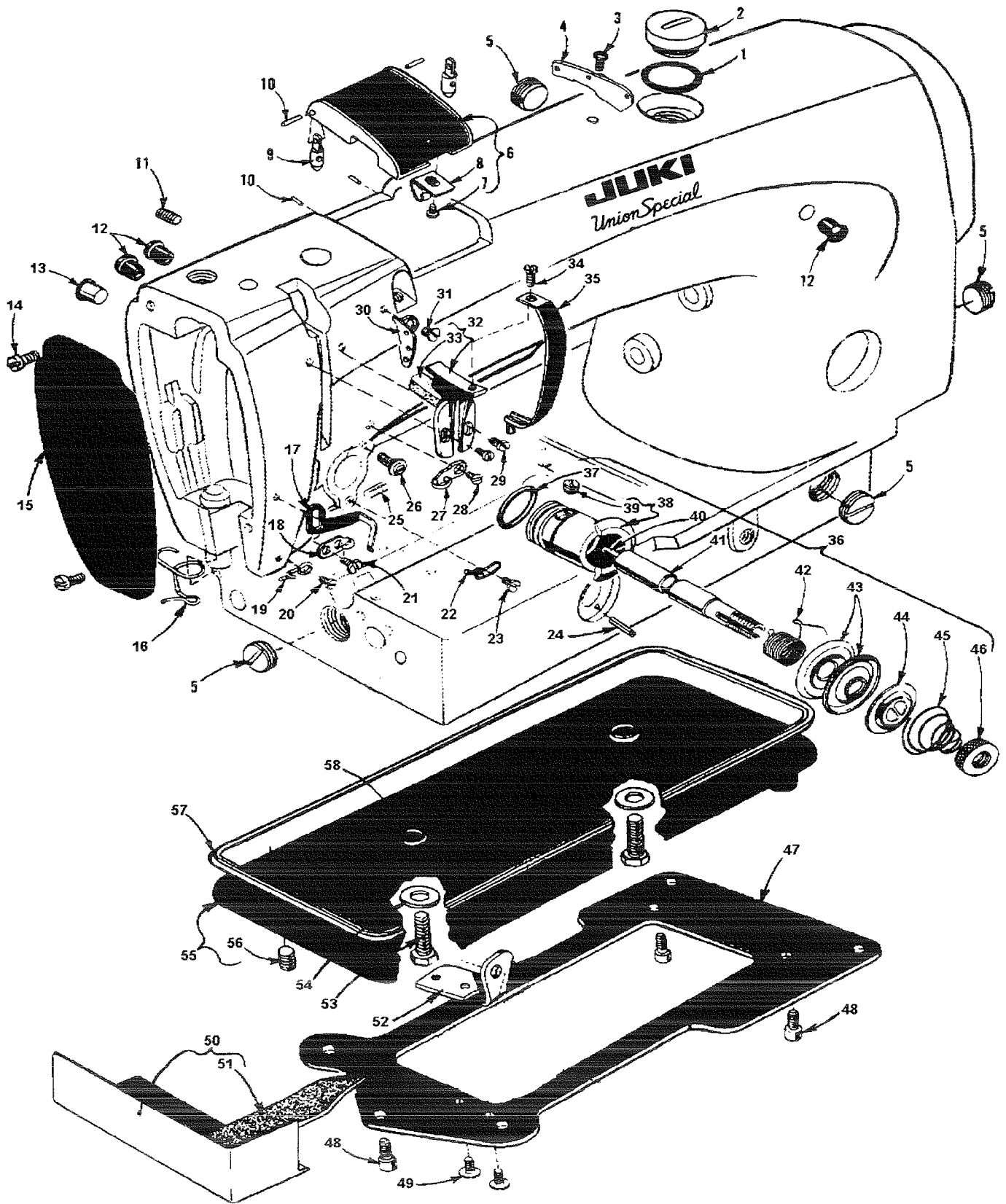

MAIN FRAME MISCELLANEOUS COVERS AND NEEDLE TENSION PARTS (CONT.)

Ref. No.	Part No.	Description	Amf. Req.
1. thru 28. see preceding page.			
29.	22562	Screw .....	2
30.	61471A	Frame Thread Eyelet .....	1
31.	22805	Screw .....	1
32.	63971A	Take-up Lever Shield .....	1
33.	666-222	Felt Pad .....	1
34.	22564	Screw .....	1
35.	63451	Take-up Shield .....	1
36.	29475AR	Thread Tension Assembly .....	1
37.	660-269A	Quad Ring .....	1
38.	61492E	Tension Post Socket .....	1
39.	22560G	Set Screw .....	1
40.	61492G	Tension Release Pin .....	1
41.	61492F	Tension Post .....	1
42.	63453	Take-up Spring .....	1
43.	109	Tension Disc .....	2
44.	61492H	Tension Release Washer .....	1
45.	61392F14	Tension Spring .....	1
46.	61292C	Tension Nut .....	1
47.	21680AX	Base Plate .....	1
48.	22652D8	Screw, for base plate .....	3
49.	22517B	Screw .....	2
50.	63996	Hook Oil Return Channel .....	1
51.	666-240	Hook Oil Return Channel Felt .....	1
52.	21662AE	Shaft Bracket, rear .....	1
53.	22644K48	Screw .....	2
54.	652-16	Washer .....	2
55.	63982C	Oil Reservoir Bottom Cover .....	1
56.	22571F	Plug Screw .....	1
57.	61482J	Gasket .....	1
58.	660-204	"O" Ring .....	2



Align flats on right end with centerline of hole for take-up lever crank pin

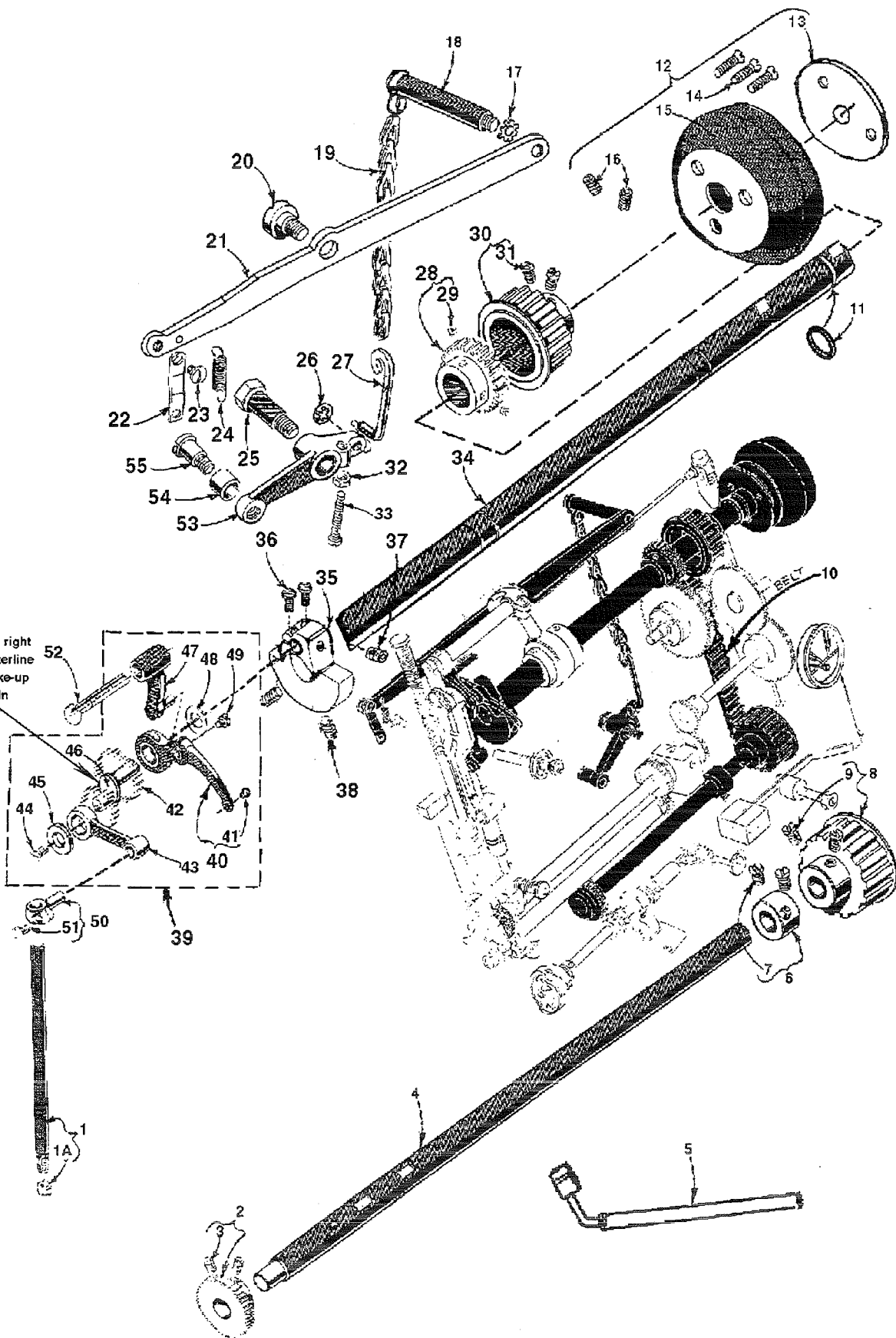



## MAIN AND HOOK DRIVE SHAFTS, NEEDLE BAR AND FOOT LIFTER MECHANISM

Ref. No.	Part No.	Description	Amt. Req.
1.	63917C	Needle Bar, marked "EN" .....	1
2.	63443	Hook Shaft Driving Gear .....	1
3.	22894C	Set Screw .....	2
4.	63940	Hook Driving Shaft .....	1
5.	63993G	Oil Return Pump .....	1
6.	61360G	Shaft Collar .....	1
7.	22884	Screw .....	2
8.	61460A	Hook Driving Shaft Sprocket .....	1
9.	22653D6	Screw .....	2
10.	61460B	Feed Driving Belt .....	1
11.	660-269	Quad Ring .....	1
12.	63921	Handwheel Assembly .....	1
13.	61421G	Hub Washer .....	1
14.	22574C	Screw .....	3
15.	63921BA	Handwheel .....	1
16.	22894V	Set Screw .....	2
17.	652B20	Lock Washer .....	1
18.	61468B	Lifter Lever Extension Stud and "S" Hook .....	1
19.	421H	Lifter Lever Chain .....	1
20.	22890A	Screw, left thread .....	1
21.	63466	Lifter Lever .....	1
22.	61467	Lifter Lever Link .....	1
23.	22758B	Screw .....	1
24.	15872F	Lifter Lever Spring .....	1
25.	22817A	Screw .....	1
26.	660-283A	Spring Grip Fastener .....	1
27.	61468D	Chain Hook .....	1
28.	63479E	Main Shaft Reduction Drive Gear .....	1
29.	22651CD-3	Set Screw .....	2
30.	61460	Main Shaft Driving Sprocket .....	1
31.	22884	Set Screw .....	2
32.	9937	Nut .....	1
33.	22874F	Screw .....	1
34.	63422	Main Shaft .....	1
35.	63491D	Counterweight .....	1
36.	22839	Screw .....	2
37.	22894W	Spot Screw .....	1
38.	22894V	Set Screw .....	2
39.	29486AB	Take-Up Lever and Needle Bar Link Assembly .....	1
40.	61451	Take-Up Lever .....	1
41.	61451G	Take-Up Lever Eyelet .....	1
42.	61451D-625	Needle Bearing, .625 inch diameter .....	38
-	61541D-626	Needle Bearing, .626 inch diameter .....	38
-	61541D-627	Needle Bearing, .627 inch diameter .....	38
43.	61455	Needle Bar Link .....	1
44.	22757D	Screw .....	1
45.	63455	Thrust Washer .....	1
46.	63952C	Take-Up Lever Crank Pin, marked "L" .....	1
47.	61451A	Take-Up Lever Link .....	1
48.	61351C	Thrust Washer .....	1
49.	22784E	Screw .....	1
50.	61255	Needle Bar Connection .....	1
51.	22562B	Screw .....	1
52.	61451B	Take-Up Lever Pin .....	1
53.	61468F	Lifter Lever Bell Crank .....	1
54.	61468E	Bell Crank Roller .....	1
55.	22712G	Screw .....	1



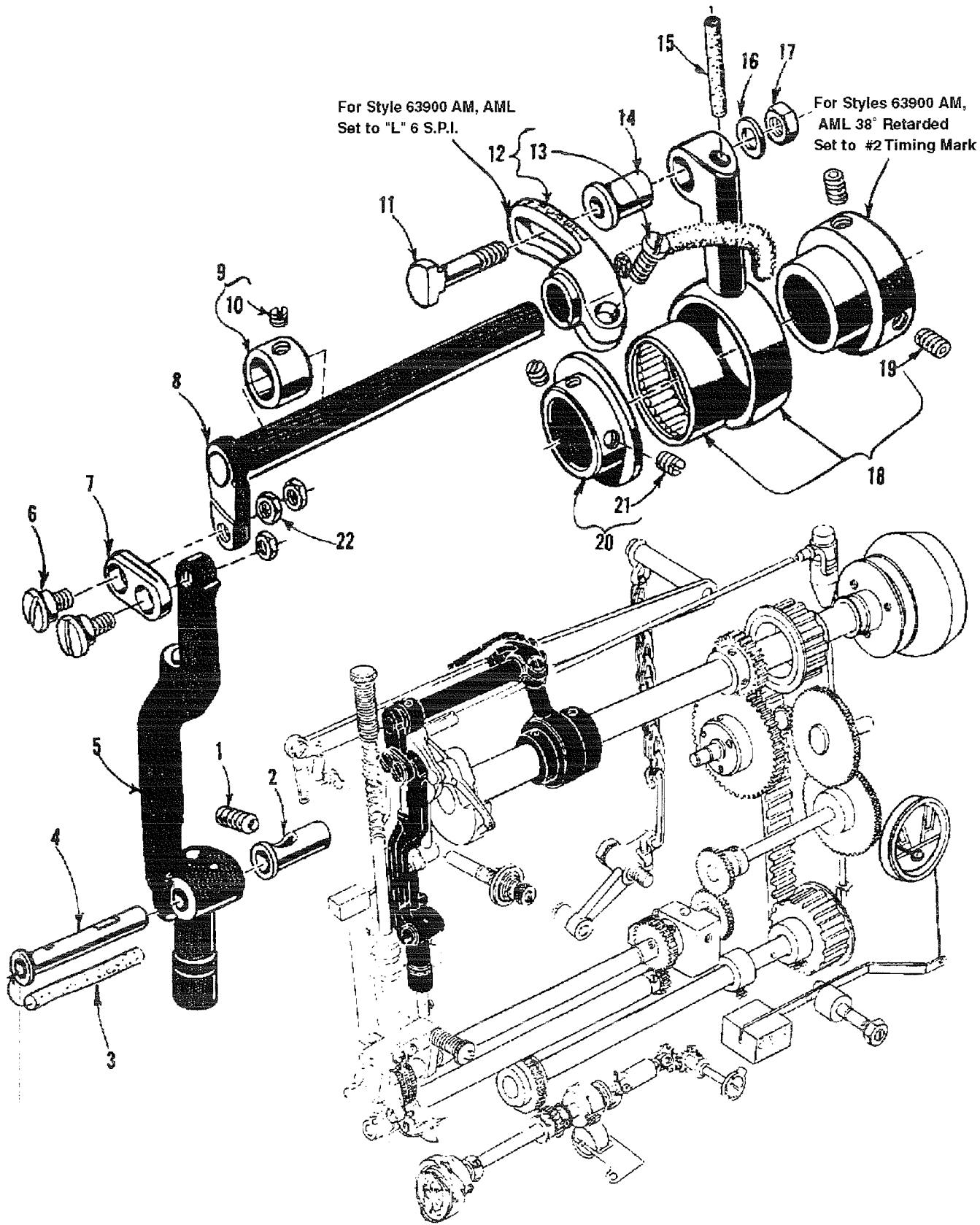

## NEEDLE FEED DRIVING PARTS

Ref. No.	Part No.	Description	Amt. Req.
1.	22894E	Screw, for needle bar frame pivot stud .....	1
2.	61985J	Needle Bar Frame Pivot Adjustable Bushing .....	1
3.	666-139	Oil Wick .....	1
4.	61985A	Needle Bar Frame Pivot Stud .....	1
5.	63985B	Needle Bar Frame .....	1
6.	22504H	Screw .....	2
7.	61985D	Needle Bar Frame Rock Shaft Connecting Link .....	1
8.	61985A	Needle Bar Frame Rock Shaft .....	1
9.	51773	Collar .....	1
10.	88B	Screw .....	1
11.	61984C	Needle Bar Drive Eccentric Connecting Stud .....	1
12.	61985F	Needle Bar Frame Rock Shaft Driving Lever .....	1
13.	22839	Clamp Screw .....	1
14.	60038G	Bearing .....	1
15.	666-173	Oil Wick .....	1
16.	20	Washer .....	1
17.	18	Nut .....	1
18.	29126EL	Needle Feed Drive Eccentric and Connecting Rod Assembly .....	1
19.	22894J	Set Screw .....	2
20.	63984A	Needle Bearing Retaining Collar .....	1
21.	95	Screw .....	2
22.	14077	Nut .....	3



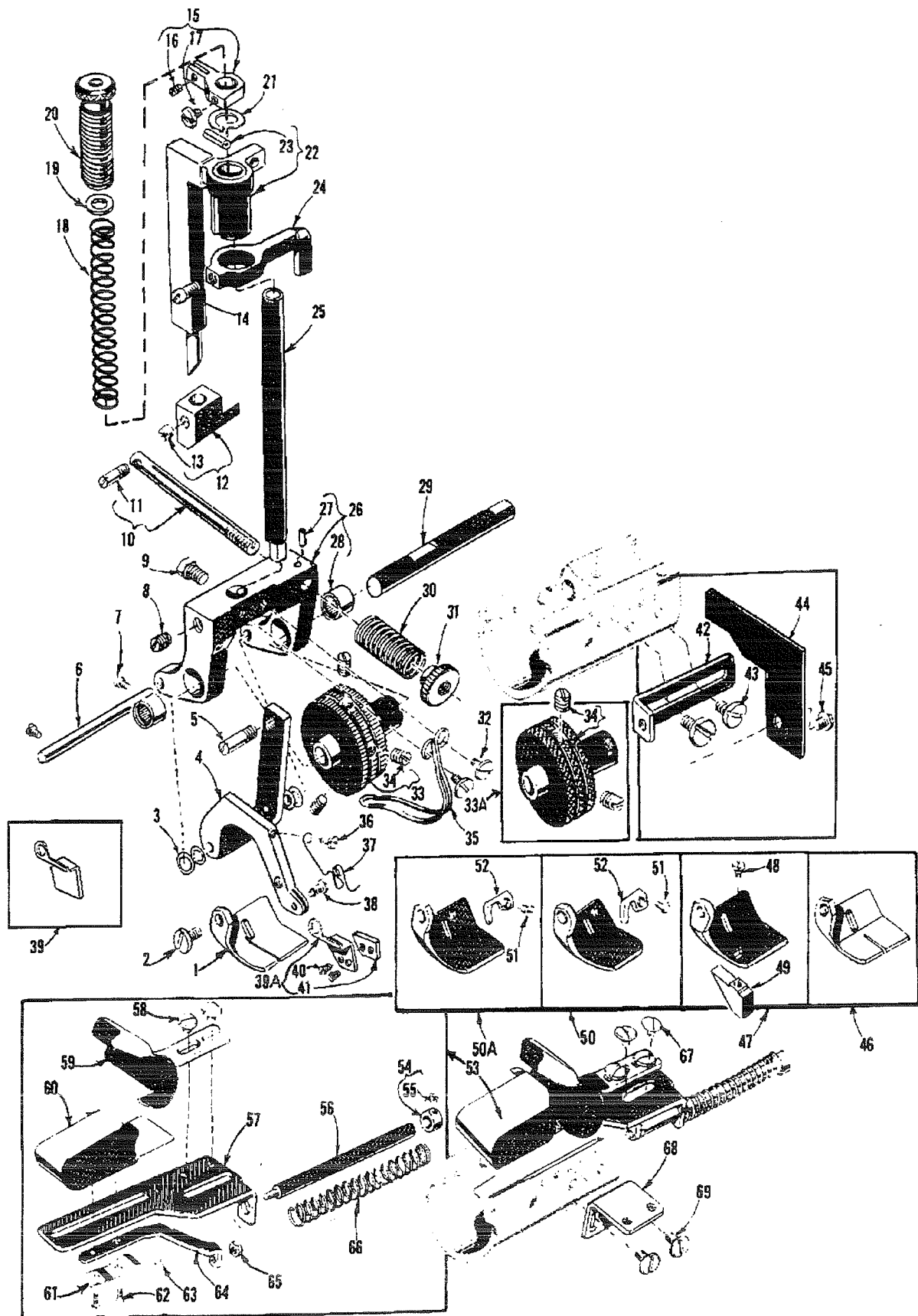

**PRESSER FEET, PRESSER BAR, TOP FEED ROLLER MECHANISM AND ATTACHMENTS**

Ref. No.	Part No.	Description	Amt. Req.
1.	63920	Presser Foot, marked "AF", for Style 63900AW .....	1
2.	22585A	Screw .....	1
3.	27-435BLK	Washer .....	4
4.	61458H	Presser Foot Shank .....	1
5.	21756G	Screw Pin .....	1
6.	61439AN	Presser Foot Shank Hinge Pin .....	1
7.	22738B	Screw .....	2
8.	95	Set Screw, for presser bar .....	1
9.	22882	Screw, for presser bar .....	1
10.	61458D	Presser Foot Tension Bar .....	1
11.	22845	Screw Pin .....	1
12.	61458C	Presser Foot Lifter Block .....	1
13.	88B	Screw .....	1
14.	230	Screw .....	1
15.	63959B	Presser Bar Guide .....	1
16.	73C	Screw .....	1
17.	22570	Screw .....	1
18.	61356	Roller Presser Spring .....	1
19.	61256G	Presser Spring Washer .....	1
20.	61257G	Presser Spring Regulator and Bushing .....	1
21.	63457R	Presser Bar Spring Washer .....	1
22.	63958	Presser Bar Connection .....	1
23.	660-219B	Roll Pin .....	1
24.	61458G	Tension Release Cam .....	1
25.	63957	Presser Bar .....	1
26.	61439AM	Top Roller Bracket .....	1
27.	54430E	Pin .....	1
28.	660-249	Needle Bearing .....	2
29.	63939K	Top Feed Roller Shaft .....	1
30.	110-4	Presser Foot Tension Regulating Spring .....	1
31.	51292C	Presser Foot Tension Regulating Nut .....	1
32.	138	Screw .....	2
33.	63939R	Top Feed Roller, 48 teeth, 1 1/4 inch diameter .....	1
*33A.	61439AG	Top Feed Roller, coarse knurl, 1 1/4 inch diameter .....	1
34.	95	Set Screw .....	2
35.	61439AP	Upper Roller Stripper .....	1

36. thru 69. see following page.

\* Available if specified on order or as an extra send and charge item.



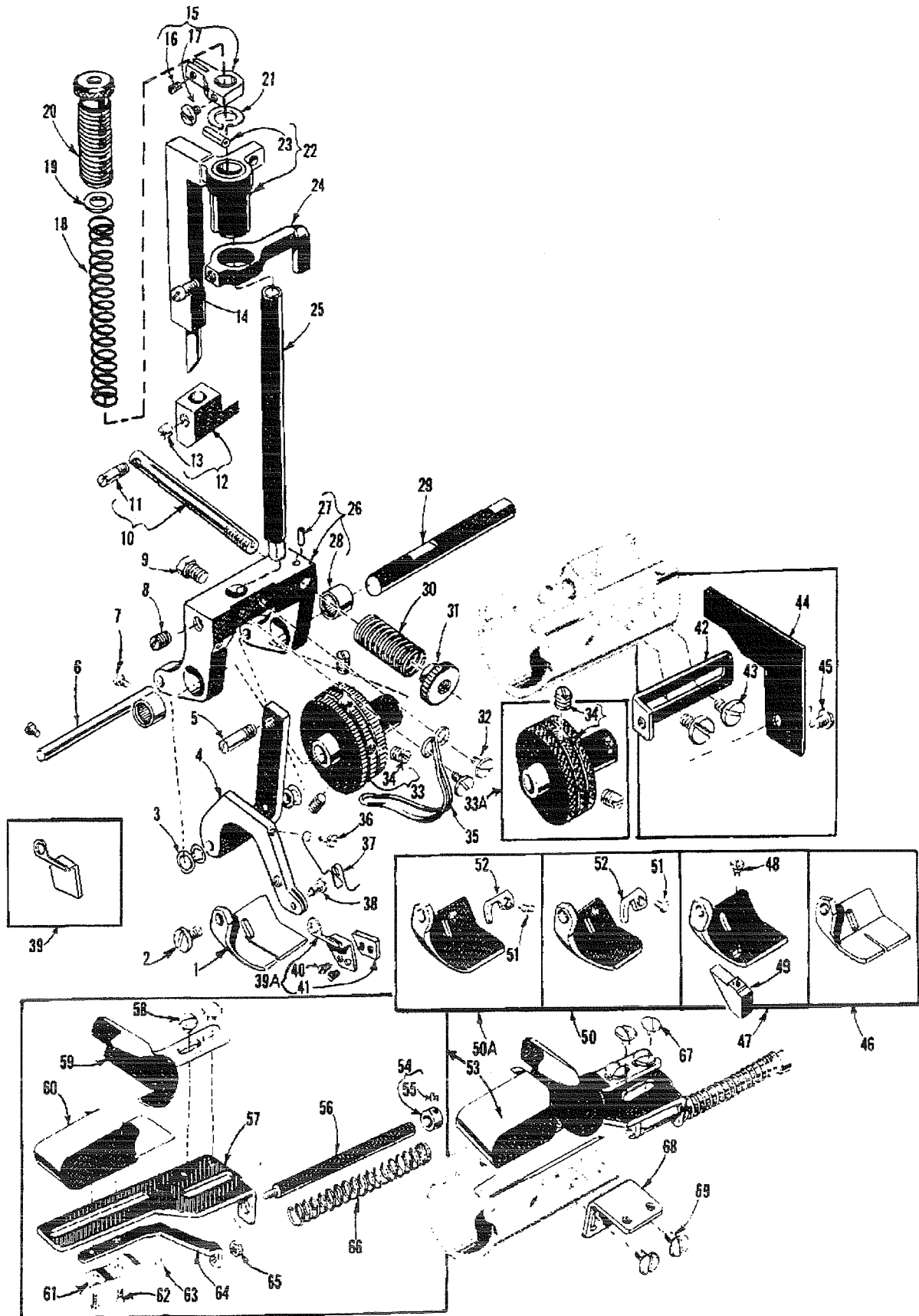

**PRESSER FEET, PRESSER BAR, TOP FEED ROLLER MECHANISM AND ATTACHMENTS**

Ref.			Amt.
No.	Part No.	Description	Req.
	1. thru 35. see preceding page.		
36.	22798A	Screw, for Styles 63900AW, AEE .....	1
37.	61430V	Spring, for edge guide, for Styles 63900AW, AEE .....	1
38.	21629	Screw, for compensating edge guide, .....	1
39.	61430CL	Edge Guide, for Style 63900AEE .....	1
39A.	61430BW	Compensating Edge Guide, for Style 63900AW .....	1
40.	22738F	Screw .....	2
41.	61430BX	Compensating Edge Guide .....	1
42.	63903	Edge Guide Mounting Bracket, for Style 63900AT .....	1
43.	22875	Screw, for edge guide mounting bracket .....	2
44.	61403	Edge Guide, for Style 63900AT .....	1
45.	22704	Screw .....	1
46.	63930A	Presser Foot Bottom, for Style 63900AAE .....	1
47.	63920A	Presser Foot, for Style 63900AT .....	1
48.	73A	Screw .....	1
49.	61430R	Presser Foot Edge Guide .....	1
50.	63920B3/8	Presser Foot, for 3/8 inch hem, on Style 63900AM .....	1
50A.	63920B1/2	Presser Foot, for 1/2 inch hem, on Style 63900AM .....	1
51.	22738B	Screw .....	1
52.	61430X	Presser Foot Needle Guard, marked "A" .....	1
53.	23564	Hemmer, complete, for making 3/8 to 1/2 inch turned don hem, on Style 63900AM .....	1
54.	6958	Collar .....	1
55.	88	Set Screw .....	1
56.	23564E	Hemmer Operating Rod .....	1
57.	23564D	Hemmer Base .....	1
58.	22711	Screw .....	2
59.	23564A	Hemmer Scroll, right .....	1
60.	23364AD	Hemmer Scroll, left .....	1
61.	23364AG	Hemmer Scroll Slide Spring .....	1
62.	22593	Screw .....	2
63.	91A	Stop Screw .....	1
64.	23564C	Hemmer Scroll Slide .....	1
65.	907	Nut .....	1
66.	20110	Hemmer Operating Rod Spring .....	1
67.	22711	Screw, for hemmer, on Style 63900AM .....	2
68.	23564G	Hemmer Mounting Bracket .....	1
69.	22517B	Screw .....	2







## ROTATING HOOK ASSEMBLY AND HOOK OILING PARTS

Ref. No.	Part No.	Description	Amt. Req.
1.	29474SA	Rotating Hook Assembly for 63900AAE, AT, AW .....	1
-	29474AH	Rotating Hook, for Style 63900AML, 1/2, 3/8, AMLZ .....	1
-	29474VA	Rotating Hook, for Style 63900AM, 1/2, 3/8 .....	1
2.	63913A	Bobbin Case Assembly .....	1
3.	61415A	Bobbin Case Latch Lever .....	1
4.	61216	Bobbin Case Latch Hinge Pin .....	1
5.	61216N	Bobbin Case Latch Spring .....	1
6.	22564M	Screw .....	2
7.	22716K	Tension Regulating Screw .....	1
8.	61414F	Bobbin Case Tension Spring .....	1
9.	63918A	Bobbin Case .....	1
10.	61415	Bobbin Case Latch .....	1
11.	61212B	Bobbin .....	1
12.	63914D	Bobbin Case Holder .....	1
13.	63907A	Hook, Thread Retainer and Thread Deflector Assembly .....	1
14.	61411B	Hook Thread Retainer .....	1
15.	22716M	Screw .....	3
16.	22569H	Set Screw .....	2
17.	63908	Hook .....	1
-	63408	Hook, for Styles 63900AML 1/2, 3/8 .....	1
18.	61210C	Hook Thread Deflector .....	1
19.	22716L	Screw .....	4
20.	61351C	Thrust Washer .....	2
21.	12865	Thrust Collar .....	1
22.	88	Screw .....	2
23.	61444	Hook Shaft Pinion .....	1
24.	89	Screw .....	2
25.	61440	Hook Shaft .....	1
26.	63432	Hook Shaft Collar, left .....	1
27.	HA73B	Screw .....	2
28.	61496V	Hook Shaft Wick Insert Assembly .....	1
29.	22868D	Screw .....	1
30.	51225W	Washer .....	1
31.	61496F	Retaining Spring .....	1
32.	61496G	Pivot Pin .....	1
33.	61496E	Hook Oil Feed Roller .....	1
34.	63496B	Metering Cup .....	1
35.	61496J	Air Seal Spring .....	1
36.	666-181	Oil Supply Felt .....	1
37.	666-182	Air Seal Felt .....	1
38.	61496C	Pump Disc .....	1
39.	660-219D	Roll Pin .....	1
40.	61496D	Pump Disc Pivot Pin .....	1
41.	35857R	Spring .....	1
42.	61496L	Hook Oil Control Shaft .....	1
43.	61496K	Hook Oil Control Finger .....	1
44.	27-527BLK	Washer .....	1
45.	22819	Screw .....	1
46.	61496P	Hook Oil Control Shaft Bushing .....	1
47.	22894R	Spot Screw .....	1
48.	61496N	Oil Control Adjusting Shaft .....	1
49.	660-221	Oil Seal Ring .....	1
50.	39198D	Spring Washer .....	1
51.	61496M	Oil Control Cog .....	2
52.	22743	Set Screw .....	1



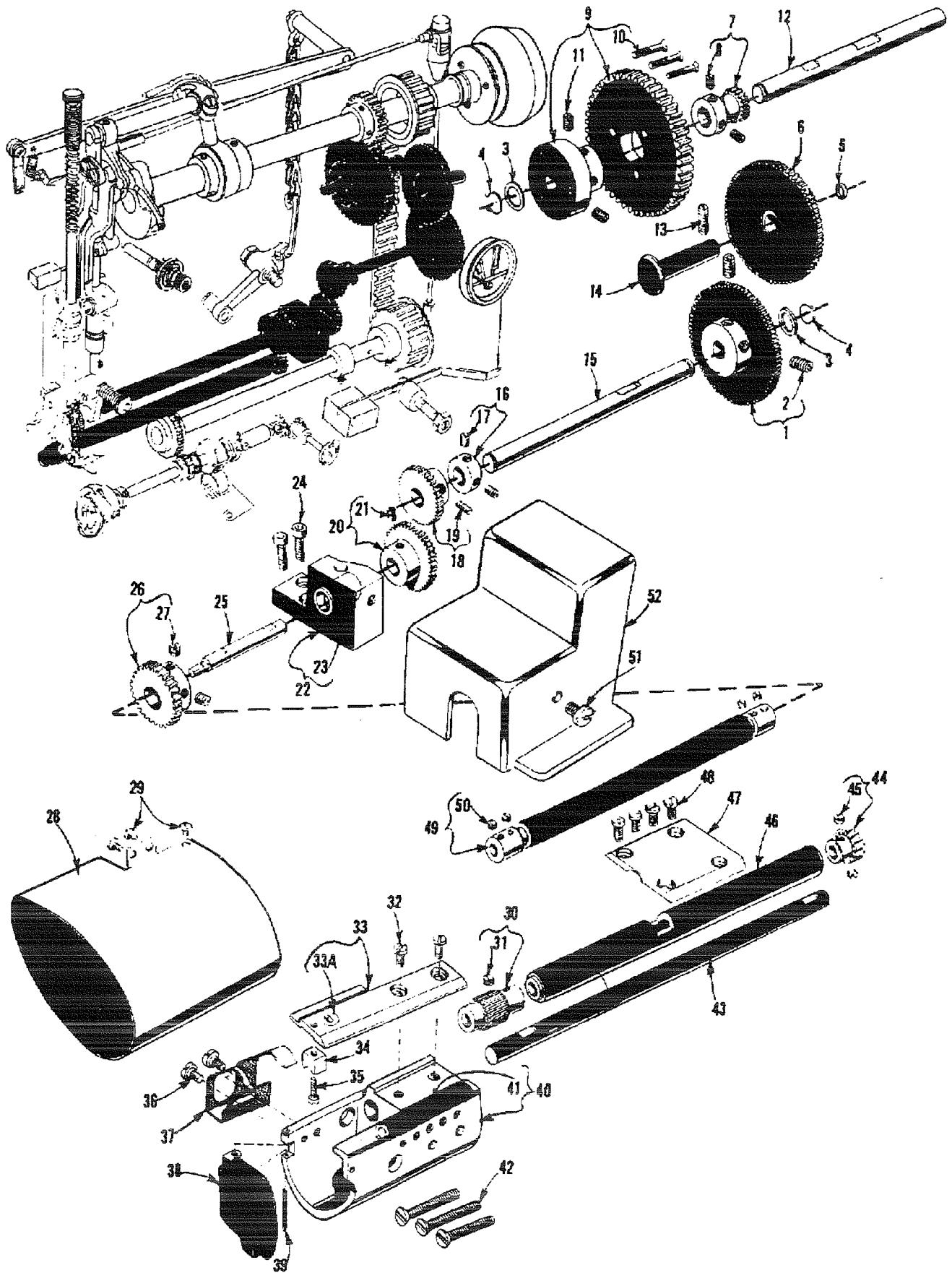

## FEED ROLLER DRIVING PARTS

Ref. No.	Part No.	Description	Amt. Req.
1.	63962H	Lower Reduction Gear .....	1
2.	22894V	Set Screw .....	2
3.	39552C	Thrust Washer .....	2
4.	660-318	Truarc Ring .....	2
5.	660-207	"O" Ring .....	1
6.	63962L	Middle Reduction Gear .....	1
7.	63962K	Upper Reduction Drive Gear .....	1
8.	22878	Set Screw .....	2
9.	63962J	Upper Reduction Driven Gear .....	1
10.	22525C	Screw .....	3
11.	22894J	Set Screw .....	2
12.	63962B	Upper Reduction Gear Shaft .....	1
13.	22597A	Set Screw .....	1
14.	63962A	Middle Reduction Gear Stud .....	1
15.	63962	Lower Reduction Gear Shaft .....	1
16.	61248H	Thrust Collar .....	1
17.	531	Screw .....	2
*18.	63949-39	Upper Stitch Regulating Gear, for Styles 63900M, T .....	1
-	63949-37	Upper Stitch Regulating Gear, for Styles 63900W, AE .....	1
19.	18-500	Set Screw .....	1
*20.	63949-41	Lower Stitch Regulating Gear, for Styles 63900M, T .....	1
-	63949-43	Lower Stitch Regulating Gear, for Styles 63900W, AE .....	1
21.	18-500	Set Screw .....	1
22.	63939	Top Feed Roller Drive Shaft Bushing Housing .....	1
23.	63939H	Top Feed Roller Drive Shaft Bushing .....	1
24.	22652B-10	Screw .....	2
25.	63939A	Top Feed Roller Drive Shaft .....	1
26.	61339D	Lower Feed Roller Drive Gear .....	1
27.	95	Set Screw .....	2
28.	63982E	Cloth Plate Extension, for Style 63900W, AE .....	1
29.	22517B	Screw, for Style 63900W, AE .....	3

30. thru 52. see following page.

\* See page 13 "Gear Chart", for the gear combinations to produce stitches per inch, other than the ones indicated.

† Available as extra send and charge item.



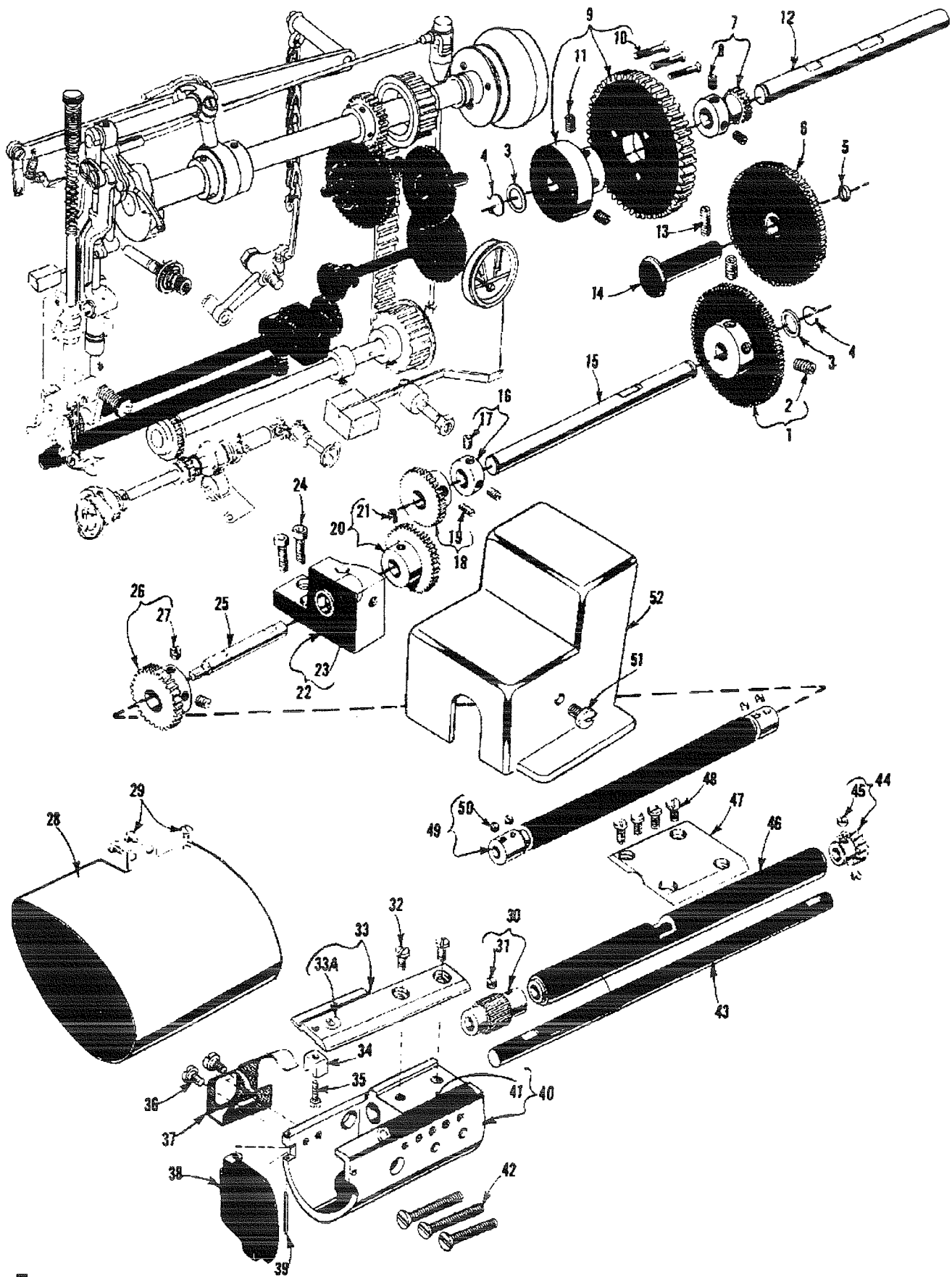

## FEED ROLLER DRIVING PARTS (CONT.)

Ref. No.	Part No.	Description	Amt. Req.
1. thru 29. see preceding page.			
30.	63939P	Lower Feed Roller, 24 teeth .....	1
†	63939E	Lower Feed Roller, medium diamond knurl .....	1
31.	22580	Set Screw .....	1
32.	22569C	Screw .....	2
33.	63928	Throat Plate .....	1
33A.	63928A	Needle Hole Insert, .080 inch dia. needle hole .....	1
34.	61414E	Bobbin Case Holder Positioning Finger .....	1
35.	22653K-6	Screw .....	1
36.	22875	Screw .....	2
37.	63939N	Lower Feed Roller Stripper .....	1
38.	63982B	Hook Housing Cover, for Styles 63900M, T .....	1
39.	660-219	Roll Pin, for Styles 63900M, T .....	1
40.	63941	Hook Shaft Bushing Housing .....	1
41.	63941A	Hook Shaft Bushing .....	1
42.	22637R-96	Screw .....	3
43.	63939B	Lower Feed Roller Drive Shaft .....	1
44.	51239E	Lower Feed Roller Driven Gear .....	1
45.	22580	Set Screw .....	2
46.	63939S	Lower Feed Drive Shaft Housing .....	1
47.	63939F	Clamp Plate .....	1
48.	22569C	Screw .....	4
49.	63939J	Top Feed Roller Flexible Drive Shaft .....	1
50.	22650AA-2	Allen Set Screw, standard No. 8-32 national coarse thread, 1/8 inch long .....	4
51.	22517B	Screw .....	1
52.	63982D	Feed Drive Gear Cover .....	1

† Available as extra send and charge item.



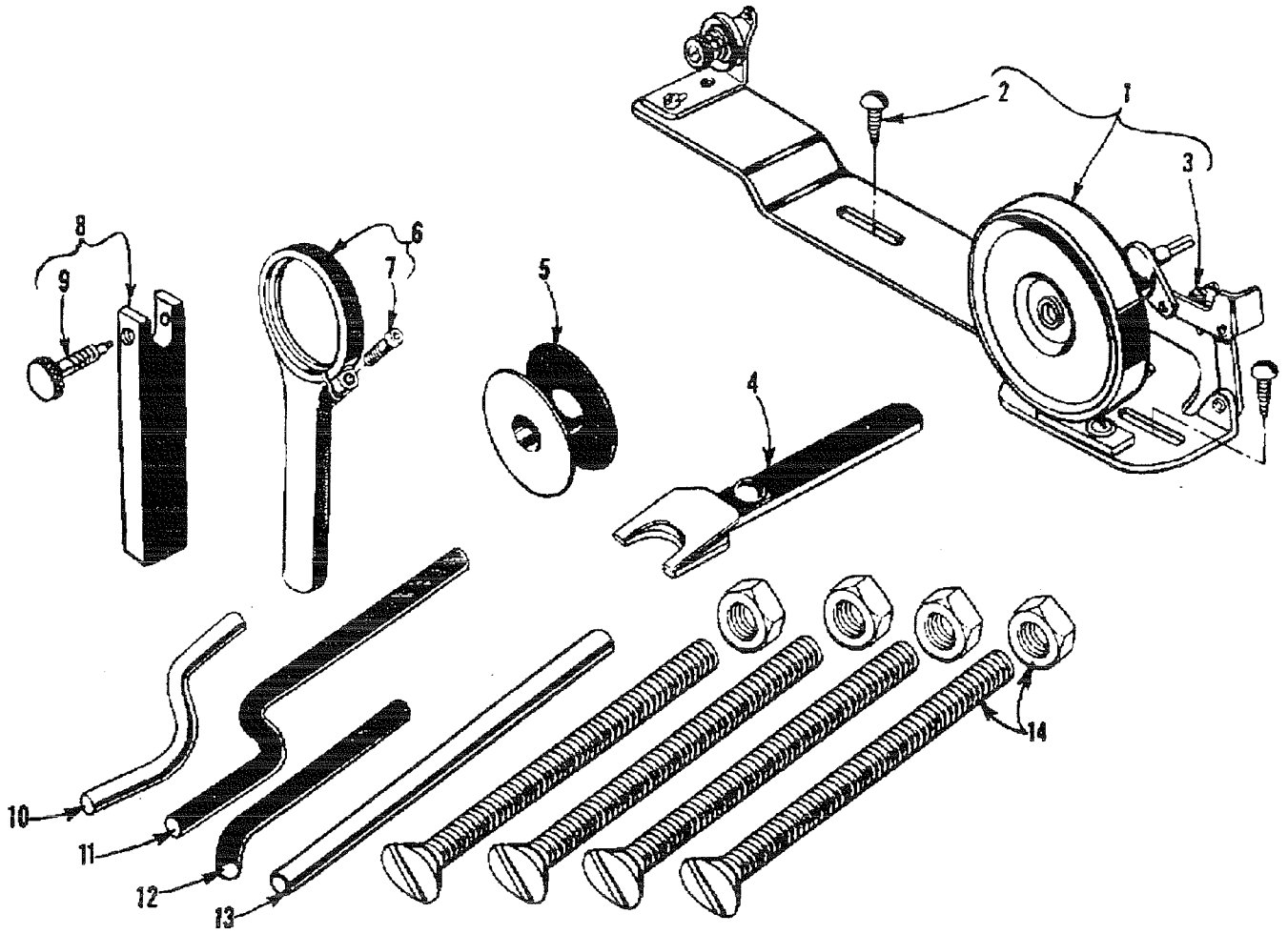

## BOBBIN WINDER AND MISCELLANEOUS ACCESSORIES

Ref. No.	Part No.	Description	Ami. Req.
1.	61477M	Bobbin Winder, complete .....	1
2.	22846M-12	Wood Screw .....	2
3.	61337N	Trip Latch .....	1
*4.	21227BY	Felt Assembly Adaptor .....	1
5.	61212	Bobbin .....	1
*6.	21388AV	Bearing Housing Puller .....	1
7.	22653E-20	Clamp Screw .....	1
*8.	21227BZ	Take-Up Eyelet Replacement Tool .....	1
9.	22789B	Thumb Screw .....	1
10.	21665L	Bell Crank Actuator Rod, for Styles 63900T, W, and AE .....	1
11.	21663F	Knee Press Plate Rod, for Style 63900M .....	1
12.	21665C	Rock Shaft Connecting Arm, for actuating folder actuator finger, for Style 63900M .....	1
13.	21663C	Knee Press Plate Rod, for Styles 63900T, W, and AE .....	1
#14.	650AC-36	Screw, for table top .....	4
-	28604S	Can of Oil, Spec. No. 175, 1 quart (not shown) .....	1
-	660-457	Dust Cover, (not shown) .....	1

\* Not furnished with machine, but may be ordered separately as an extra send and charge.

# Not furnished with machine, but is a component of 1400D pedestal.



## NUMERICAL INDEX OF PARTS

Part No.	Page No.	Part No.	Page No.	Part No.	Page No.	Part No.	Page No.	Part No.	Page No.
109	31	22716L	41	51239E	45	61467	33	63479E	33
110-4	37	22716M	41	51292C	37	61468B	33	63490B	27
11635B	27	22733D	29	51773	35	61468D	33	63491D	33
12865	41	22738B	37, 39	531	43	61468E	33	63492	29
138	37	22738F	39	54430E	37	61468F	33	63494A	29
14077	35	22743	41	56393AA	25	61470C	29	63494B	29
15872F	33	22757D	33	60038G	35	61470D	29	63494C	25
18	35	22758B	33	61210C	41	61471A	31	63494D	27
18-500	43	22766	29	61212	47	61477M	47	63494F	27
20	35	22784E	33	61212B	41	61482J	31	63494G	27
20110	39	22784K	25	61216	41	61490B	25	63494K	27
21227BY	47	22789B	47	61216N	41	61490C	25	63494M	25
21227BZ	47	22798A	39	61248H	43	61490D	25	63496B	41
21388AV	47	22805	31	61255	33	61492E	31	63903	39
21629	39	22815	25	61256G	37	61492F	31	63907A	41
21662AE	31	22817A	33	61257G	37	61492G	31	63908	41
21663C	47	22819	41	61292C	31	61492H	31	63913A	41
21663F	47	22839	33, 35	61293N	27	61494D	25	63914D	41
21665C	47	22845	37	61337N	47	61494E	25	63917C	33
21665L	47	22846M-12	47	61339D	43	61494H	27	63918A	41
21680AX	31	22863B	29	61351C	33, 41	61494L	25	63920	37
21756G	37	22868D	41	61356	37	61494N	25	63920A	39
22504H	35	22874F	33	61360G	33	61494T	27	63920B1/2	39
22513D	29	22875	39, 45	61392F14	31	61496C	41	63920B3/8	39
22516	29	22878	43	61403	39	61496D	41	63921	33
22517B	31, 39	22882	37	61411B	41	61496E	41	63921BA	33
22517B	43, 45	22884	33	61414E	45	61496F	41	63928	45
22525C	43	22890A	33	61414F	41	61496G	41	63928A	45
22539P	29	22890C	27	61415	41	61496J	41	63930A	39
22560G	31	22894C	33	61415A	41	61496K	41	63939	43
22562	31	22894E	29, 35	61421G	33	61496L	41	63939A	43
22562B	33	22894J	35, 43	61430BW	39	61496M	41	63939B	45
22564	25, 27, 31	22894R	41	61430BX	39	61496N	41	63939E	45
22564M	41	22894V	33, 43	61430CL	39	61496P	27, 41	63939F	45
22569B	25	22894W	33	61430R	39	61496S	27	63939H	43
22569C	45	230	37	61430V	39	61496V	41	63939J	45
22569H	41	23364AD	39	61430X	39	61541D-626	33	63939K	37
22570	37	23364AG	39	61432B	27	61541D-627	33	63939N	45
22570A	29	23564	39	61439AG	37	61982C	29	63939P	45
22571F	31	23564A	39	61439AM	37	61982D	29	63939R	37
22574C	33	23564C	39	61439AN	37	61984C	35	63939S	45
22580	45	23564D	39	61439AP	37	61985A	35	63940	33
22585A	37	23564E	39	61439AR	37	61985D	35	63941	45
22593	39	23564G	39	61440	41	61985F	35	63941A	45
22597A	43	27-435BLK	37	61441A	27	61985G	25	63949-37	43
22597E	29	27-527BLK	41	61444	41	61985H	25	63949-39	43
22637R-96	45	28604S	47	61451	33	61985J	35	63949-41	43
22644K48	31	29126EL	35	61451A	33	63408	41	63949-43	43
22650AA-2	45	29474AH	41	61451B	33	63422	33	63949R	25
22651CD-3	33	29474SA	41	61451D-625	33	63432	41	63952C	33
22652B-10	43	29474VA	41	61451G	33	63432C	27	63953A	25
22652D8	31	29475AR	31	61455	33	63443	33	63957	37
22653D6	33	29486AB	33	61458C	37	63451	31	63957A	25
22653E-20	47	35857R	41	61458D	37	63453	31	63958	37
22653K-6	45	39198D	41	61458G	37	63455	33	63959B	37
22704	39	39552C	43	61458H	37	63457R	37	63962	43
22711	39	421H	33	61460	33	63466	33	63962A	43
22712G	33	51-159BLK	25	61460A	33	63470	29	63962B	43
22716K	41	51225W	41	61460B	33	63470A	29	63962C	27





## NUMERICAL INDEX OF PARTS

Part No.	Page No.	Part No.	Page No.
63962D	27	666-234	27
63962E	27	666-237	27
63962F	27	666-238	27
63962G	27	666-239	27
63962H	43	666-240	31
63962J	43	666-254	25
63962K	43	6958	39
63962L	43	73A	39
63970A	29	73C	37
63970B	29	88	39, 41
63971A	31	88B	35, 37
63982	29	89	41
63982A	29	90	29
63982B	45	907	39
63982C	31	91A	39
63982D	45	95	35, 37, 43
63982E	43	9937	33
63982F	29	HA73B	41
63984A	35	HS24C	29
63984C	25		
63985B	35		
63993B	27		
63993C	25		
63993D	25		
63993G	33		
63993H	27		
63994	25		
63994C	29		
63996	31		
650AC-36	47		
652-16	31		
652B20	33		
660-204	31		
660-207	43		
660-219	45		
660-219A	29		
660-219B	37		
660-219D	41		
660-221	27, 41		
660-249	37		
660-269	33		
660-269A	31		
660-283A	33		
660-318	43		
660-409	29		
660-455	27		
660-457	47		
666-139	35		
666-173	35		
666-181	41		
666-182	41		
666-200	25		
666-214	25		
666-221	27		
666-222	31		
666-223	25		
666-224	25		
666-225	25		
666-228	25		



## NOTES

---

---

---

---

---

---

---

---

---

---

---

---

---

---

---

---

---

---

---

---

---

---

---

---

---

---

