

# JUKI

2-Needle, Feed-off-the-arm Double Chainstitcher/Cloth Puller  
高速筒型二本針二重環縫ミシン/先引装置付

**MS-1260/V045**

3-Needle, Feed-off-the-arm Double Chainstitcher for Jeans/Cloth Puller  
高速筒型三本針二重環縫ミシン/先引装置付

**MS-1261/V045**



## PARTS LIST

---

## HOW TO MAKE USE OF THIS PARTS LIST

1. An asterisk (\*) means that the corresponding part is changed from the previous parts list or is newly added.
2. As to "#01" and "#02," refer to the "Note" given at the bottom of the respective pages.
3. Codes on the "Qty" column
  - Each numeral indicates the number of parts required.
  - "0.1" and "2.0" indicate the length (in meters) of the respective parts.
4. Parentheses mean that the corresponding part is a subpart that constructs an assembly part.
5. Dotted lines on the Figures indicate assembly parts.

### パーツリストご利用に際して

1. Note欄に記載されているリストページの\*印は、前回の内容に対して、今回変更または追加された部品であることを意味します。
2. リストページの#01、#02等の印は、ページ下の“注記”の説明をご参照ください。
3. ・数量覧の数字は、個数を表し、0.1、2.0等の数値は、長さ（単位メートル）を表します。
4. 数量覧の( )は、組部品を構成している子部品であることを意味します。
5. イラストページの———枠は、組構成であることを意味します。

# CONTENTS

## 目次

### SEWING MACHINE COMPILATION

#### ミシン編

1. FRAME & MISCELLANEOUS COVER COMPONENTS .....	1
頭部・外装関係	
2. LOOPER THREAD GUIDE COMPONENTS .....	3
カム系案内関係	
3. NEEDLE BAR & MAIN SHAFT COMPONENTS .....	5
針棒・上軸関係	
4. PRESSER BAR & LOWER SHAFT COMPONENTS .....	7
押さえ棒・下軸関係	
5. FEED MECHANISM COMPONENTS .....	9
送り関係	
6. LOOPER & FEED DOG COMPONENTS .....	11
ルーパ・送り歯関係	
7. KNEE LIFTER COMPONENTS .....	13
膝上げ関係	
8. THREAD STAND COMPONENTS .....	15
糸立装置関係	

### V045 COMPILATION

#### V045編

9. FRAME & COVER COMPONENTS .....	17
フレーム・カバー関係	
10. DRIVE COMPONENTS .....	18
駆動関係	
11. CLUTCH COMPONENTS .....	19
クラッチ関係	
12. ROLLER DRIVE COMPONENTS .....	20
ローラー駆動関係	
13. PRESSER COMPONENTS .....	21
押さえ関係	
14. TABLE OF EXCHANGING GAUGE PARTS .....	23
交換ゲージ一覧表	
NUMERICAL INDEX OF PARTS .....	26
索引	

SEWING MACHINE COMPILATION

ミシン編

1. FRAME & MISCELLANEOUS COVER COMPONENTS

頭部・外装関係

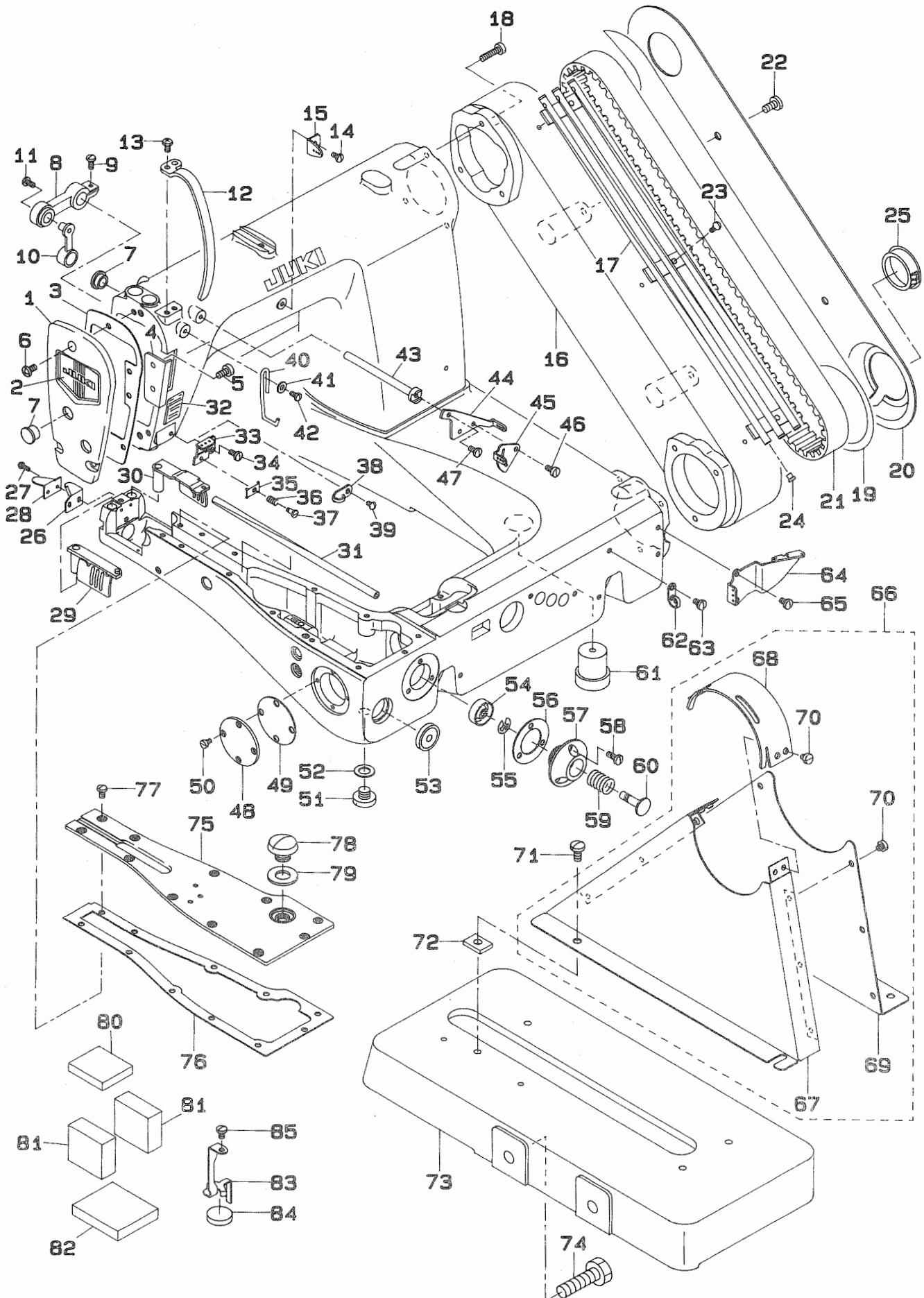

REF.NO	NOTE	PART NO.	DESCRIPTION	ヒンメイ	Qty
1		129-50705	FACE PLATE	メンハン	1
2		110-00403	PLATE	メンイタケシヨウイタ	1
3		129-21003	FACE PLATE GASKET	メンイタ ハッキン	1
4		129-50804	FACE PLATE SIDE PLATE	メンイタソクメンイタ	1
5		SS-6110610-TP	SCREW 11/64-40 L=6	ヒラネジ 11/64-40 L=6	2
6		SS-4120915-SP	SCREW 3/16-28 L=9	ナハネジ 3/16-28 L=9	3
7		TA-1250406-RO	RUBBER PLUG	トメセン D=12.5 L=4	3
8		B1162-026-0A0	TENSION RELEASE ARM ASM.	チューカン イトユルメウチ クミ	1
9		SS-4091010-SP	SCREW 9/64-40 L=10	ナハネジ 9/64-40 L=10	1
10		B1161-026-000	CONNECTING LINK	チューカン イトユルメ リンク	1
11		SS-5090710-SP	SCREW 9/64-40 L= 6.5	トラスネジ 9/64-40 L=6.5	1
12		129-23207	TENSION COVER	テンヒンカハ	1
13		SS-4110815-SP	SCREW 11/64-40 L=8	ナハネジ 11/64-40 L=8	1
14		SS-7090710-SP	SCREW 9/64-40 L= 6.8	マルヒラネジ 9/64-40 L=6.8	1
15		129-66800	UPPER THREAD GUIDE	チェウカンウツイ トアンナイ	1
16		129-51000	SPROCKET WHEEL COVER	スプロケットハグカハ	1
17		129-67501	LOWER THREAD TUBE (A)	シタイトウカン (A)	1
18		SS-6122030-SP	SCREW 3/16-28 L=20	ヒラネジ 3/16-28 L=20	6
19		129-21508	WHEEL COVER GASCKET	ハグカハマカハ ハッキン	1
20		129-21409	SPROCKET WHEEL COVER PLATE	スプロケット ハグカハマカハ フタ	1
21		B1219-019-000	TIMING BELT	タイミンク ムルト	1
22		SS-7151210-SP	SCREW 15/64-28 L=12	マルヒラネジ 15/64-28 L=12	2
23		SS-4091010-SP	SCREW 9/64-40 L=10	ナハネジ 9/64-40 L=10	3
24		B1128-804-000	THREAD GUIDE	イトミチ	6
25		129-21607	RUBBER PLUG	ハグカハマカハ フタ セン	1
26		B1130-026-000	CHAIN CUTTER BLADE (A)	イトキリ A	1
27		SS-3060710-SP	SCREW 3/32-56 L=6.8	マルネジ 3/32-56 L=6.8	2
28		B1131-026-000	CHAIN CUTTER BLADE (B)	イトキリ B	1
29		129-52552	LEFT GATE LOOPER COVER ASM.	ヒタリカワルハカハ (クミ)	1
30		129-52255	RIGHT GATE LOOPER COVER ASM.	ミキカワルハカハ (クミ)	1
31		B1157-019-000	LOOPER THREAD TUBE (C)	シタイト トーカン C	1
32		129-50507	THREAD INDICATION LABEL	ハリヒヨウシシール	1
33	#01	129-55803	THREAD TENSION DISK HOLDER	ハリイトチヨウシチラウケ	1
34	#01	SS-7090910-SP	SCREW 9/64-40 L= 8.5	マルヒラネジ 9/64-40 L=8.5	1
35	#01	B1134-850-000-A	THREAD TENSION DISC	ハリイトチヨウシチラウケ	1
36	#01	B1135-850-000	TENSION SPRING (A)	ハリイト チヨウシチネ A	1
37	#01	SD-0380551-SL	HINGE SCREW D= 3.80 H= 5.5	タンネジ D=3.8 H=5.5	1
38	#02	B1130-051-000	FRAME THREAD GUIDE, MIDDLE	イトアンナイ	1
39	#02	SS-3090610-SP	SCREW 9/64-40 L=6	マルネジ 9/64-40 L=6	1
40		129-65703	THREAD TAKE-UP TENSION LEVER	テンヒンイトチヨウシチレハ	1
41		WP-0450801-SD	WASHER 4.5X10.0X0.8	ヒラネジ 4.5X10X0.8	1
42		SS-5091020-SP	SCREW 9/64-40 L= 9.5	トラスネジ 9/64-40 L=9.5	1
43		129-66909	TENSION RELEASE LEVER SHAFT	チェウカンイトユルメシク	1
44		129-67006	TENSION RELEASE LEVER	チェウカンイトユルメレハ	1
45		129-67105	NEEDLE THREAD TENSION GUIDE	ハリイトチヨウシチトアンナイ	1
46		SS-8090540-SP	SCREW 9/64-40 L= 5.0	ヒラネジ 9/64-40 L=5	2
47		SS-7090710-SP	SCREW 9/64-40 L= 6.8	マルヒラネジ 9/64-40 L=6.8	1
48		B1805-019-000	FRONT BUSHING COVER	シタジク マエメタル フタ	1
49		B1806-019-000	GASKET	シタジク マエメタル ハッキン	1
50		SS-8090620-SP	SCREW 9/64-40 L=6	ヒラネジ 9/64-40 L=6	4
51		SS-7740740-SP	SCREW 3/8-28 L= 6.5	マルヒラネジ 3/8-28 L=6.5	2
52		129-22605	GASKET	トレン ハッキン	2
53		107-04203	OIL POT WINDOW	オイルポットマト	1
54		B1633-191-000	CAP RETAINER	オンボタンジクカハ	1
55		RE-0400000-K0	E-SHAPED SNAP RING (4MM)	Eカクタメ 4	1
56		B1634-191-000	GASKET	オンボタンジク ハッキン	1
57		B1630-191-000	PUSH BUTTON GUIDE	オンボタンジクウケ	1
58		SS-7111120-SP	SCREW 11/64-40 L=10.5	マルヒラネジ 11/64-40 L=10.5	3
59		B1632-191-000	SPRING	オンボタンハネ	1
60		B1631-191-000	FEED ECCENTRIC ADJUSTING KNOB	オンボタンジク	1
61		B1156-019-000	RUBBER CUSHION, C	ホーツン ゴム C	1
62		110-18603	ARM THREAD GUIDE B	アームイトアンナイ B	1
63		SS-7110710-SP	SCREW 11/64-40 L=7	マルヒラネジ 11/64-40 L=7	1
64		129-40102	LOOPER THREAD GUIDE PLATE	シタイト アンナイイタ	1
65		SS-7110710-SP	SCREW 11/64-40 L=7	マルヒラネジ 11/64-40 L=7	2
66		B1104-191-0A0	BELT COVER ASM.	ムルトカハ (クミ)	1
67		B1104-191-00A	BELT COVER	ムルトカハ	(1)
68		B1104-191-00B	TOP COVER	トップカハ	(1)
69		B1104-191-00C	BELT COVER PLATE	ムルトカハ フタ	(1)
70		SS-6110480-SP	SCREW 11/64-40 L=4.3	ヒラネジ 11/64-40 L=4.3	(10)
71		SS-7151210-SP	SCREW 15/64-28 L=12	マルヒラネジ 15/64-28 L=12	4
72		B1106-191-000	CUSHION	ムルトヨケ クツヨシチ	4
73		129-43700	BELT GUARD INSTALLING BASE	ムルトヨケイ	1
74		SS-9284043-CP	SCREW 7/16-16 L=40	ロツカクボルト 7/16-16 L=40	2
75		129-51950	BED COVER ASM.	ムットマトイタ (クミ)	1
76		129-52008	BED COVER GASKET	マトイタハッキン	1
77		SS-5110810-SP	SCREW 11/64-40 L=8	トラスネジ 11/64-40 L=8	11
78		SS-5820540-SP	SCREW 1/2-28 L=5.0	トラスネジ	1
79		B1140-019-000	GASKET	アフラタメ ハッキン	1
80		129-70406	FELT A	エホウフェルト A	1
81		B3513-261-000	FELT, B	エホウフェルト B	2
82		B3526-226-000	FELT, C	エホウフェルト C	1
83		129-43205	MAGNET SUPPORT PLATE	マリネット シンイタ	1
84		B8228-125-000	OIL RESERVOIR MAGNET	ジンヤク	(1)
85		SS-7110710-SP	SCREW 11/64-40 L=7	マルヒラネジ 11/64-40 L=7	1

Note (注記) #01... FOR MS-1261  
#02... FOR MS-1260

MS-1261 用  
MS-1260 用

## 2. LOOPER THREAD GUIDE COMPONENTS

カム糸案内関係

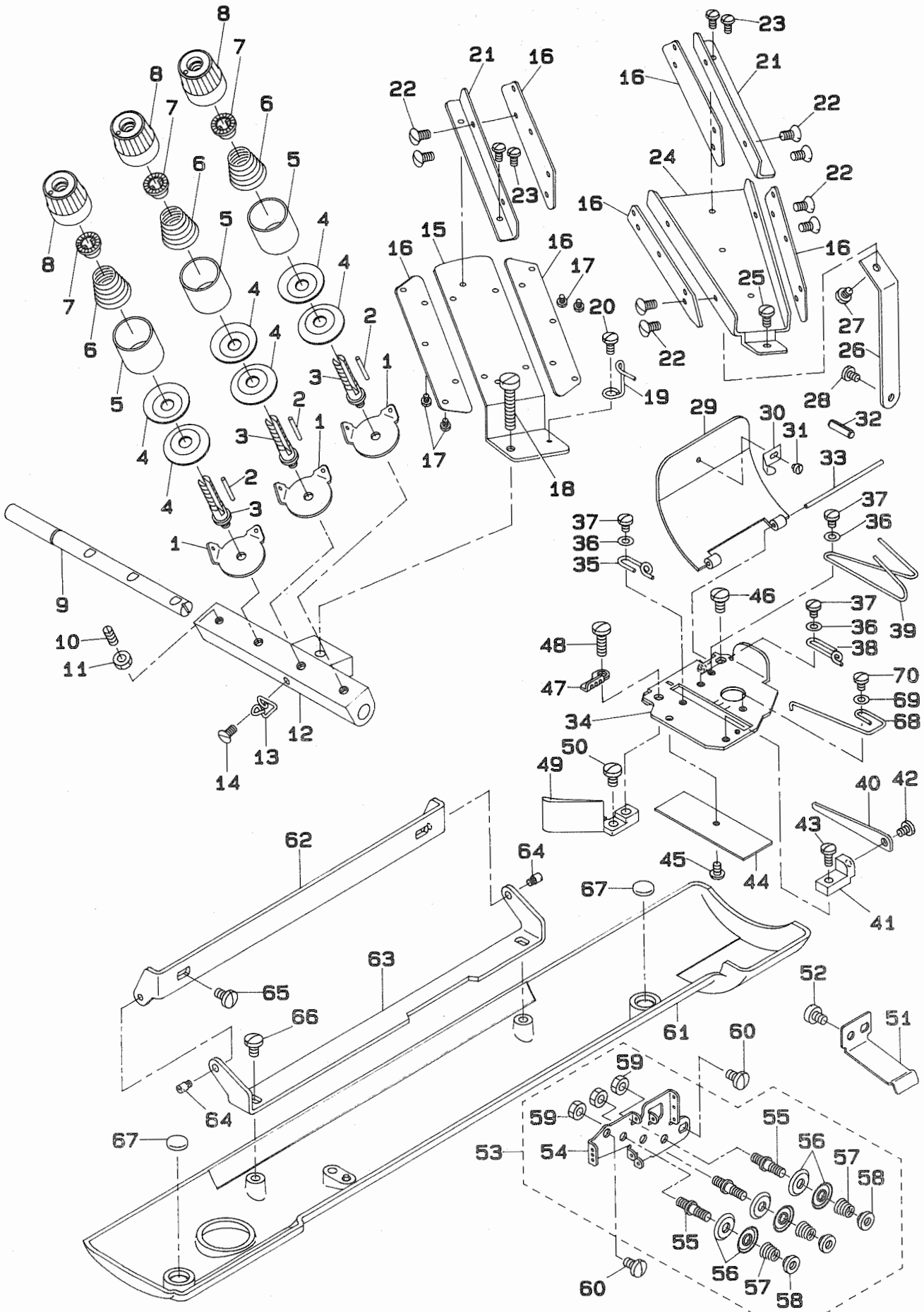

REF.NO	NOTE	PART NO.	DESCRIPTION	ヒンメイ	Qty
1		115-50308	THREAD GUIDE	チヨ-シチラ イトアンナイ	3
2		B2310-019-000	TENSION RELEASING PIN	イトユルメ ヒン	(3)
3		129-38205	TENSION POST	イトチヨウシホウ	3
4		B3126-012-000	THREAD TENSION DISK	イトチヨ-シチラ	(6)
5		B3107-804-000	THREAD TENSION DISK PRESSER	イトチヨ-シチラ オサエ	3
6		129-38304	TENSION SPRING	イトチヨウシハネ	3
7		B3112-704-000	TENSION SPRING BUSHING	ハネ フツシユ	3
8		119-57008	THREAD TENSION KNOB	イトチヨウシツマミ (ムシヨク)	3
9		129-66602	TENSION RELEASING SHAFT	イトユルメシク	1
10		SS-8111160-SP	SCREW 11/64-40 L=11.0	トメネジ 11/64-40 L=11	1
11		NS-6110310-SP	NUT 11/64-40	ロツカクナツト 11/64-40	1
12		B2301-261-00A	THREAD TENSION ROD BASE	イトチヨウシホウウタイ	1
13		129-66701	LOWER THREAD GUIDE (LEFT)	シタイトイトアンナイ (ヒタリ)	1
14		SS-7090510-SP	SCREW 9/64-40 L= 4.6	マルヒラネジ 9/64-40 L=4.6	1
15		129-67600	THREAD GUIDE MOUNTING BRACKET	ウワイトイトアンナイイタ	1
16		B2402-019-000	THREAD GUIDE	オオキイタ イトアンナイ	6
17		SS-7060510-SP	SCREW 3/32-56 L=4.8	マルヒラネジ 3/32-56 L=4.8	4
18		SS-4622340-SP	SCREW 3/16-32 L=23	ナハネジ 3/16-32 L=23	1
19		B2421-019-000	THREAD EYELET	ウワイト イトアンナイ	1
20		SS-7090510-SP	SCREW 9/64-40 L= 4.6	マルヒラネジ 9/64-40 L=4.6	1
21		129-67303	THREAD GUIDE FITTING PLATE	イトアンナイトリツケイタ	2
22		SS-2060510-SP	SCREW 3/32-56 L=4.5	マルチラネジ 3/32-56 L=4.5	8
23		SS-5060410-SP	SCREW 3/32-56 L=3.5	トラスネジ 3/32-56 L=3.5	4
24		129-67204	THREAD GUIDE BRACKET	オオキイタ	1
25		SS-7090710-SP	SCREW 9/64-40 L= 6.8	マルヒラネジ 9/64-40 L=6.8	1
26		129-67402	THREAD GUIDE BRACKET SUPPORT	オオキイタイトアンナイオサエ	1
27		SS-7090520-SP	SCREW 9/64-40 L= 4.5	マルヒラネジ 9/64-40 L=4.5	1
28		SS-4091010-SP	SCREW 9/64-40 L=10	ナハネジ 9/64-40 L=10	1
29		129-36803	LOOPER THREAD TAKE-UP COVER	カムカハ	1
30		B2208-019-000	LOOPER THREAD TAKE-UP COVER SP	カムカハ ハネ	1
31		SS-6060210-SP	SCREW 3/32-56 L= 1.9	ヒラネジ 3/32-56 L=1.9	1
32		PS-0500202-KP	SPRING PIN 5X20	スプリングヒン 5.0X20	1
33		129-36902	LOOPER THREAD TAKE-UP PIN	カムカハ ヒン	1
34		129-35516	TENSION TAKE-UP STRIPPER PLATE	イトチヨウシカムイタ	1
35		129-66305	LOOPER THREAD GUIDE (C)	カムイトアンナイ (C)	1
36		WP-0371016-SD	WASHER 3.7X8X1	ヒラサカネ 3.7X8X1	3
37		SS-7090530-SP	SCREW 9/64-40 L= 4.5	マルヒラネジ 9/64-40 L=4.5	3
38		129-66206	LOOPER THREAD GUIDE (B)	カムイトアンナイ(B)	1
39		129-66107	LOOPER THREAD GUIDE (A)	カムイトアンナイ (A)	1
40		129-66008	LOOPER THREAD CAM PRESSER	シタイトカムオサエ	1
41		129-35607	CAM HOLDER BRACKET	シタイト カムオサエ トリツケイ	1
42		SS-7090530-SP	SCREW 9/64-40 L= 4.5	マルヒラネジ 9/64-40 L=4.5	1
43		SS-7090850-SP	SCREW 9/64-40 L=8	マルヒラネジ 9/64-40 L=8	1
44		129-36217	FELT	エボウフェルト	1
45		SS-5090420-SP	SCREW 9/64-40 L=3.5	トラスネジ 9/64-40 L=3.5	1
46		SS-7110840-SP	SCREW 11/64-40 L=7.8	マルヒラネジ 11/64-40 L=7.8	1
47		129-35805	LOOPER THREAD GUIDE	シタイトカム イトアンナイ(D)	1
48		SS-7111410-SP	SCREW 11/64-40 L=14	マルヒラネジ 11/64-40 L=14	1
49		129-36506	STRIPPER PLATE BRACKET	カムイタ トリツケイ	1
50		SS-7110710-SP	SCREW 11/64-40 L=7	マルヒラネジ 11/64-40 L=7	1
51		129-22803	COVER SPRING	シタイト カハ スプリング	1
52		SS-6110610-TP	SCREW 11/64-40 L=6	ヒラネジ 11/64-40 L=6	2
53		129-67758	LOOPER THREAD TENSION ASM.	シタイトチヨウシ (クミ)	1
54		129-39500	TENSION BASE PLATE	シタイトチヨウシ トリツケイタ	(1)
55		129-39609	TENSION POST	シタイト チョウセツシク	(3)
56		129-39708	TENSION DISC	シタイト イトチヨウシチラ	(6)
57		129-67709	LOOPER THREAD TENSION SPRING	シタイトチヨウシハネ	(3)
58		129-39906	TENSION NUT	シタイト チョウシ タイヤル	(3)
59		NS-6110350-SP	NUT 11/64-40	ロツカクナツト 11/64-40	(3)
60		SS-7110710-SP	SCREW 11/64-40 L=7	マルヒラネジ 11/64-40 L=7	2
61		129-51505	LOOPER THREAD TUBE COVER	シタイトウカクカハ	1
62		129-21904	LOOPER THREAD TUBE COVER HING	シタイト カハヒンジ A	1
63		129-22001	LOOPER THREAD TUBE COVER HING	シタイト カハヒンジ B	1
64		B1534-816-000	HINGE SCREW	タニナイオサエ ヒンジネジ	2
65		SS-7110840-SP	SCREW 11/64-40 L=7.8	マルヒラネジ 11/64-40 L=7.8	2
66		SS-7110840-SP	SCREW 11/64-40 L=7.8	マルヒラネジ 11/64-40 L=7.8	2
67		115-03604	VIBRATION-PROOF PLUG B	ヌメイ ホーシセン B	2
68		129-35904	LOOPER THREAD GUIDE	シタイトカム アンナイホウ	1
69		WP-0371016-SD	WASHER 3.7X8X1	ヒラサカネ 3.7X8X1	1
70		SS-7090530-SP	SCREW 9/64-40 L= 4.5	マルヒラネジ 9/64-40 L=4.5	1

### 3. NEEDLE BAR & MAIN SHAFT COMPONENTS

針棒・上軸關係

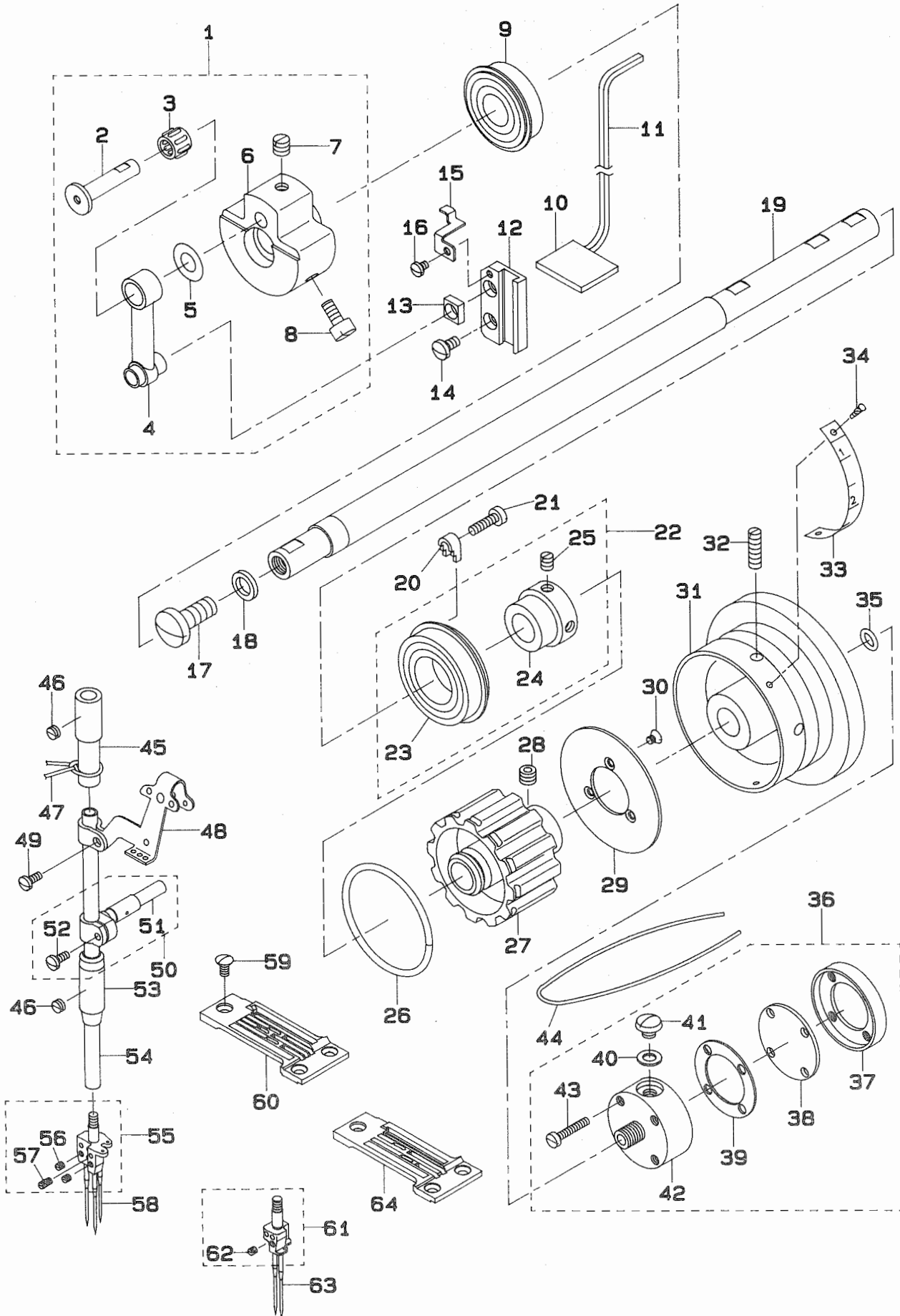



REF.NO	NOTE	PART NO.	DESCRIPTION	ヒ ン メ イ	Qty
1		B1207-026-OA0	COUNTERWEIGHT ASM.	ツリアイモリ クミ	1
2		B1209-019-OA0	NEEDLE BAR CRANK PIN ASM.	ハリホー クランクピン クミ	(1)
3	#01	B1236-125-BA0	NEEDLE BUSHING ASM.	ニートルハアリンク	(1)
4		B1408-038-000	NEEDLE BAR CRANK ROD, B	ハリホー クランクロッド B	(1)
5		B1208-019-000	WASHER	ハリホー クランクロッド シカネ	(1)
6		B1207-026-000	COUNTERWEIGHT	ツリアイモリ	(1)
7		SS-8660610-TP	SCREW 1/4-40 L=6	トメネジ 1/4-40 L=6	(2)
8		SS-6151220-SP	SCREW 15/64-28 L=11.5	ヒラネジ 15/64-28 L=11.5	(2)
9		B1202-512-000	MAIN SHAFT BUSHING, FRONT	ウワシク マエハアリンク	1
10		B3510-019-000	OIL FELT	カンリユ フェルト	1
11		B3541-012-000	OIL WICK	カンリユ エジン	1
12		B1412-038-000	SLIDE BLOCK GUIDE	コロ アンナイタ	1
13		B1411-019-000	SLIDE BLOCK GUIDE	ハリホー タキ アンナイコロ	1
14		SS-7120910-SP	SCREW 3/16-28 L=9	マルヒラネジ 3/16-28 L=9	2
15		129-43106	OIL WICK PRESSER	エジンオサエ	1
16		SS-7090530-SP	SCREW 9/64-40 L= 4.5	マルヒラネジ 9/64-40 L=4.5	1
17		SS-7740740-SP	SCREW 3/8-28 L= 6.5	マルヒラネジ 3/8-28 L=6.5	1
18		B1222-019-000	PACKING	ウワシク アブラトメ カワハツキン	1
19		129-24502	MAIN SHAFT	ウワシク	1
20		129-24809	METAL PRESSER	メタルオサエ	3
21		SS-6111610-SP	SCREW 11/64-40 L=16	ヒラネジ 11/64-40 L=16	3
22		129-24759	BUSHING REAR ASM.	ウシロメタル(クミ)	1
23		B1203-512-000	MAIN SHAFT BUSHING, REAR	ウワシク ウシロハアリンク	(1)
24		129-24700	BUSHING	メタルフツシ	(1)
25		SS-8150710-SP	SCREW 15/64-28 L=7	トメネジ 15/64-28 L=7	(2)
26		B1214-019-000	SPROCKET RING	スプロケツ リンク	2
27		B1211-019-000	SPROCKET WHEEL (A)	スプロケツ A	1
28		SS-8660522-TP	SCREW 1/4-40 L=4.5	トメネジ 1/4-40 L=4.5	2
29		129-25004	PULLEY PLATE	プーリ プレート	1
30		SS-1090510-SP	SCREW 9/64-40 L=5	チラネジ 9/64-40 L=5	3
31		129-55209	HAND WHEEL	ハスマイクルマ	1
32		SS-8152030-SP	SCREW 15/64-28 L=20	トメネジ 15/64-28 L=20	2
33		129-55308	HAND WHEEL SCALE PLATE	ハスマイクルマメモリタ	1
34		B1161-227-000	RIVET	トメヒョー (キンイロ)	2
35		RO-0982401-00	RUBBER RING	ORリング	1
36		B3501-019-OA0	OIL CUP BODY ASM.	オイルカップ クミ	1
37		B3504-019-000	OIL CUP BODY CAP RETAINER	オイルカップ フタ	(1)
38		B3502-019-000	OIL CUP BODY CAP	オイルカップ マト	(1)
39		B3503-019-000	OIL CUP BODY CAP GASKET	オイルカップ マトハツキン	(1)
40		B3508-019-000	WASHER	アブラ チューニユ ネジ ハツキン	(1)
41		SS-5660440-SP	SCREW 1/4-40 L= 4.0	トラスネジ 1/4-40 L=4	(1)
42		B3501-019-000	OIL CUP BODY	オイルカップ タイ	(1)
43		SS-6092120-SP	SCREW 9/64-40 L=21.2	ヒラネジ 9/64-40 L=21.2	(4)
44		CQ-2520000-00	OIL WICK	エジン	1
45		B1402-026-BOG	NEEDLE BAR BUSHING, UPPER	ハリホー ウワメタル	1
46		SS-8150310-SP	SCREW 15/64-28 L= 3.4	トメネジ 15/64-28 L=3.4	2
47		CQ-3000000-00	OIL WICK	エジン	0.1
48		B1901-026-000	THREAD TAKE-UP	テンビン	1
49		SS-7090910-TP	SCREW 9/64-40 L= 8.5	マルヒラネジ 9/64-40 L=8.5	1
50		B1409-019-OR0	NEEDLE BAR CLAMP ASM.	ハリホー タキ クミ	1
51		B1418-019-000	FELT	ハリホー タキ キユエフェルト	(1)
52		SS-7090910-SP	SCREW 9/64-40 L= 8.5	マルヒラネジ 9/64-40 L=8.5	(1)
53		B1404-026-BOG	NEEDLE BAR BUSHING, LOWER	ハリホー シタメタル	1
54		B1401-026-000	NEEDLE BAR	ハリホー	1
55	#03	129-56256	NEEDLE CLAMP (1/4") ASM.	ハリメ (1/4") クミ	1
56		SS-8080310-TP	SCREW 1/8-44 L=2.8	トメネジ 1/8-44 L=2.8	(2)
57		SS-8080610-SP	SCREW 1/8-44 L=5.5	トメネジ 1/8-44 L=5.5	(1)
58	#02	MC-3800013-00	NEEDLE UY128GAS NM130	ハリ UY128GAS NM130	3
59		SS-2110920-TP	SCREW 11/64-40 L=8.5	マルチラネジ 11/64-40 L=8.5	3
60	#03	129-53204	NEEDLE PLATE XH (1/4")	ハリタ XH(1/4")	1
61	#04	129-25954	NEEDLE CLAMP 3/16 ASM.	ハリメ 3/16(クミ)	1
62		SS-8080310-TP	SCREW 1/8-44 L=2.8	トメネジ 1/8-44 L=2.8	(2)
63	#04	MC-3800012-00	NEEDLE UY128GAS NM120	ハリ UY128GAS NM120	2
64	#04	129-77906	NEEDLE PLATE MH (3/16")	ハリタ MH(3/16")	1

Note (注記) #01...SELECTIVE PART

#02...FOR MS-1261

#03...REFER TO THE TABLE OF EXCHANGING PARTS ON P.23

#04...FOR MS-1260

選択部品

MS-1261 用

23 ページの交換部品一覧表を  
ご参照下さい。

MS-1260 用

# 4. PRESSER BAR & LOWER SHAFT COMPONENTS

押さえ棒・下軸関係

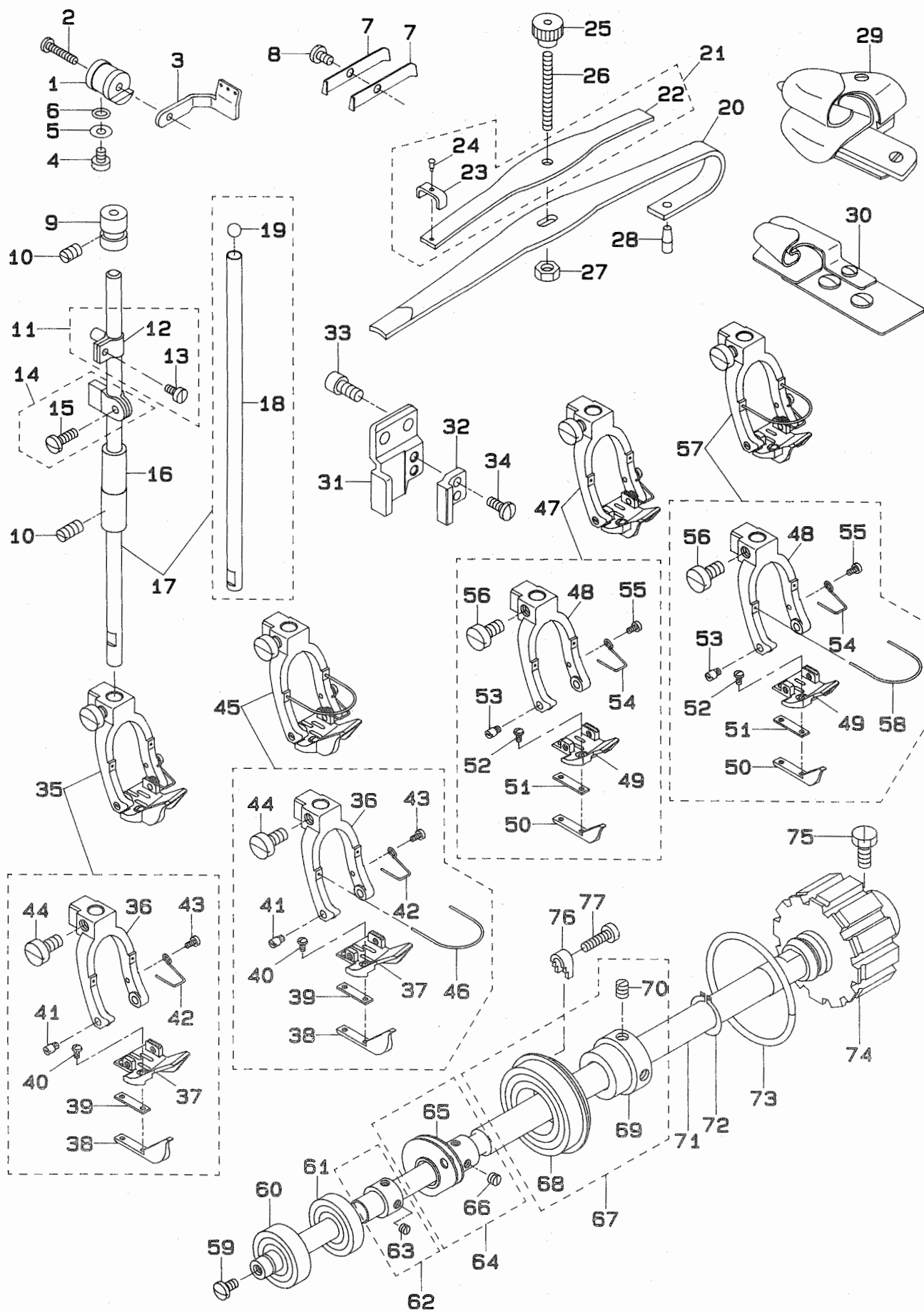

REF.NO	NOTE	PART NO.	DESCRIPTION	ヒンメイ	Qty
1		129-68103	FITTING SHAFT	シタイトアンナイトリツカシク	1
2		SS-7091410-SP	SCREW 9/64-40 L=13.5	マルヒラネジ 9/64-40 L=13.5	1
3		129-68202	LOOPER THREAD EYELET	ル-ハ°-イトアンナイ	1
4		SS-8110610-TP	SCREW 11/64-40 L=6	ヒラネジ 11/64-40 L=6	1
5		WP-0450000-SD	WASHER 4.5X8X0.5	ヒラネジカネ 4.5X8X0.5	1
6		RO-0481901-00	RUBBER RING	ORリング	1
7		B1127-026-000	LOOPER GATE RETAINING SPRING	ル-ハ°カハ°- オサエ	2
8		SS-7090710-SP	SCREW 9/64-40 L= 6.8	マルヒラネジ 9/64-40 L=6.8	1
9		B1502-019-000	PRESSER BAR UPPER BUSHING	オサエホ°- ウラメタル	1
10		SS-8150310-SP	SCREW 15/64-28 L= 3.4	トメネジ 15/64-28 L=3.4	2
11		B1411-552-0A0	NEEDLE ROD HOLDER ASM.	ハリホ°-タ°キ クミ	1
12		B1411-552-000	NEEDLE BAR CLAMP	ハリホ°-タ°キ	(1)
13		SS-8090670-TP	SCREW 9/64-40 L=6	ヒラネジ 9/64-40 L=6	(1)
14		B1504-019-0A0	PRESSER BAR GUIDE BRACKET ASM.	オサエホ°-タ°キ クミ	1
15		SS-7111110-TP	SCREW 11/64-40 L=10.5	マルヒラネジ 11/64-40 L=10.5	(1)
16		129-58609	BUSHING, LOWER	オサエホ°ウシタメタル	1
17		129-58559	PRESSER BAR ASM.	オサエホ°ウ (クミ)	1
18		129-58500	PRESSER BAR	オサエホ°ウ	(1)
19		B1506-019-000	PRESSER BAR STEEL BALL	オサエホ°- タマ	(1)
20		129-58807	PRESSER LIFTER SPRING	オサエアケ°ハ°ネ	1
21		129-59052	UPPER SPRING ASM.	オサエアケ°ウエハ°ネ (クミ)	1
22		129-59003	PRESSER LIFTER UPPER SPRING	オサエアケ°ウエハ°ネ	(1)
23		129-59102	PRESSER LIFTER SETSCREW	オサエアケ°ハ°ネト°メ	(1)
24		A1161-001-00B	RIVET	トメヒ°ヨ° (キ°ンロ)	(1)
25		B2326-019-000	PRESSER REGULATING SCREW NUT (	オサエ チョ°セツナツト B	1
26		B2324-261-000	PRESSER REGULATING SCREW	オサエチヨ°セツネジ°	1
27		NS-6120310-SP	NUT 3/16-28	ロツカクナツト 3/16-28	1
28		B2328-019-000	PRESSER BAR SPRING PIN	オサエアケ° ハ°ネヒ°ン	1
29	#01	MAM-2990BBBA	HOLDER 1/4XH ASM.	ホルタ°- 1/4XH (ソウクミ)	1
30	#01	MAM-2970CCBA	HOLDER 3/16 MH	ホルタ°- 3/16 MH	1
31		129-59300	PRESSER FOOT GUIDE (A)	オサエアジカ°イト° (A)	1
32		129-59409	PRESSER FOOT GUIDE (B)	オサエアジカ°イト° (B)	1
33		SM-6061202-TP	SCREW M6 L=12	ロツカクアナホ°ルト M6 L=12	2
34		SS-7110910-TP	SCREW 11/64-40 L= 8.5	マルヒラネジ 11/64-40 L=8.5	2
35	#01	129-60050	PRESSER 1/4" ASM.	オサエ 1/4" (クミ)	1
36		129-60803	PRESSER FOOT (7/32", 1/4")	オサエアジ (7/32", 1/4")	(1)
37		129-60001	PRESSER (1/4")	オサエ (1/4")	(1)
38		129-62007	ADJUSTING PRESSER XH	チョウセツオサエ XH	(1)
39		129-62106	PRESSER ADJUSTING PLATE (A)	オサエチヨウセツイタ (A)	(1)
40		SS-5060410-SP	SCREW 3/32-56 L=3.5	トラスネジ 3/32-56 L=3.5	(2)
41		B1534-816-000	HINGE SCREW	タ°ンヌイオサエ ヒンジ°ネジ°	(2)
42		129-62205	PRESSER SPRING	オサエハ°ネ	(1)
43		SS-6060410-TP	SCREW 3/32-56 L= 3.5	ヒラネジ 3/32-56 L=3.5	(1)
44		SS-6150810-SP	SCREW 15/64-28 L=8	ヒラネジ 15/64-28 L=8	(1)
45	#01	129-60068	PRESSER 1/4" (ASM) EXPORT	オサエ 1/4" (クミ) ヌシユウ	1
46		129-62304	NEEDLE GUARD	ニ°ト°ルカ°°ト°	(1)
47	#01	129-78250	PRESSER MH (3/16") ASM.	オサエ MH (3/16") (クミ)	1
48		129-78409	PRESSER FOOT (3/16")	オサエアジ (3/16")	(1)
49		129-78201	PRESSER MH (3/16")	オサエ MH (3/16")	(1)
50		129-78508	ADJUSTING PRESSER MH	チョウセツオサエ MH	(1)
51		129-73608	PRESSER ADJUSTING PLATE (C)	オサエチヨウセツイタ (C)	(1)
52		SS-5060410-SP	SCREW 3/32-56 L=3.5	トラスネジ 3/32-56 L=3.5	(2)
53		B1534-816-000	HINGE SCREW	タ°ンヌイオサエ ヒンジ°ネジ°	(2)
54		129-62205	PRESSER SPRING	オサエハ°ネ	(1)
55		SS-6060410-TP	SCREW 3/32-56 L= 3.5	ヒラネジ 3/32-56 L=3.5	(1)
56		SS-6150810-SP	SCREW 15/64-28 L=8	ヒラネジ 15/64-28 L=8	(1)
57	#01	129-78268	PRESSER MH (3/16") ASM. EXPORT	オサエ MH (3/16") (クミ) ヌシユウ	1
58		129-62304	NEEDLE GUARD	ニ°ト°ルカ°°ト°	(1)
59		SS-7110830-SP	SCREW 11/64-40 L= 7.5	マルヒラネジ 11/64-40 L=7.5	1
60		B1802-019-000	BALL BEARING, FRONT	シタジ°クマエ °°アリンク°	1
61		B1803-019-000	BALL BEARING, INTERMEDIATE	シタジ°クナカ °°アリンク°	1
62		B1808-019-0A0	SLEEVE ASM.	シタジ°ク ナカメタル °°ツシユ クミ	1
63		SS-8110310-SP	SCREW 11/64-40 L= 2.8	トメネジ 11/64-40 L=2.8	2
64		129-66552	LOOPER THREAD CAM ASM.	シタイトカム (クミ)	1
65		129-66503	LOOPER THREAD CAM	シタイトカム	(1)
66		SS-8110310-SP	SCREW 11/64-40 L= 2.8	トメネジ 11/64-40 L=2.8	2
67		129-24759	BUSHING REAR ASM.	ウシロメタル (クミ)	1
68		B1203-512-000	MAIN SHAFT BUSHING, REAR	ウシジ°ク ウシロ°°アリンク°	(1)
69		129-24700	BUSHING	メタル°°ツシユ	(1)
70		SS-8150710-SP	SCREW 15/64-28 L=7	トメネジ 15/64-28 L=7	(2)
71		129-65505	LOWER SHAFT	シタジ°ク	1
72		RC-1200001-KP	C-SHAPED SNAP RING	Cカ°タメワ	1
73		B1214-019-000	SPROCKET RING	スプ°ロケツト リンク°	1
74		B1212-019-B00	SPROCKET WHEEL B	スプ°ロケツト ハケ°ルマ B	1
75		SS-9151440-CP	SCREW 15/64-28 L=14	ロツカクホ°ルト 15/64-28 L=14	2
76		129-24809	METAL PRESSER	メタルオサエ	3
77		SS-6111610-SP	SCREW 11/64-40 L=16	ヒラネジ 11/64-40 L=16	3

Note (注記) #01...REFER TO THE TABLE OF EXCHANGING PARTS ON P.23

23 ページの交換部品一覧表をご参照下さい。

# 5. FEED MECHANISM COMPONENTS

送り関係

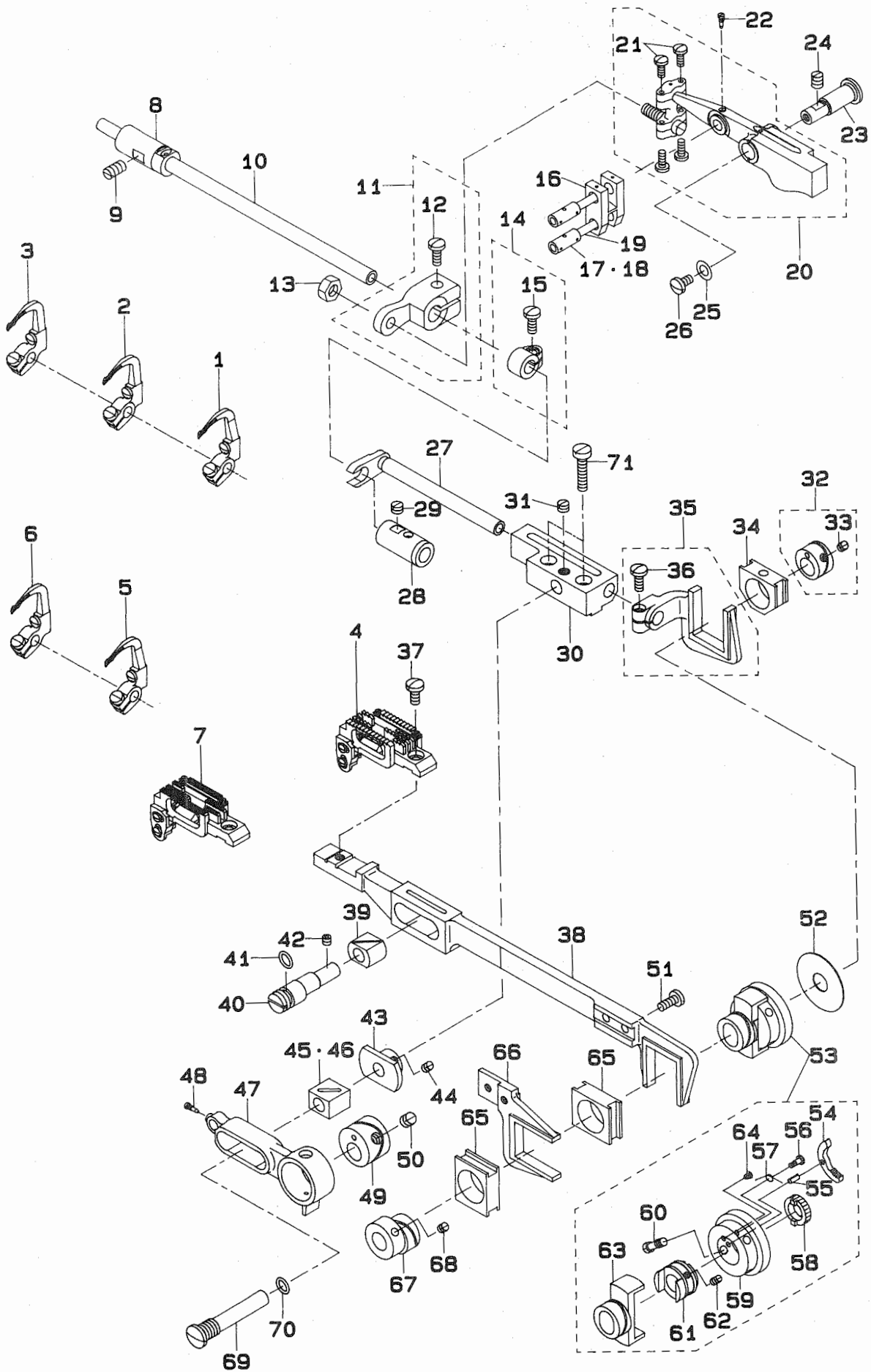

REF.NO	NOTE	PART NO.	DESCRIPTION	ヒンメイ	Qty
1	#01	129-68558	LOOPER L (1) ASM.	ル-ハ° - L(1) (クミ)	1
2	#01	129-68855	LOOPER R (1) ASM.	ル-ハ° - R(1) (クミ)	1
3	#01	129-69150	LOOPER C (1) ASM.	ル-ハ° - C(1) (クミ)	1
4	#01	129-63351	FEED DOG XH(1/4") ASM.	オクリハ° XH(1/4") (クミ)	1
5	#02	129-79258	LOOPER L (3) ASM.	ル-ハ° - L(3) (クミ)	1
6	#02	129-79357	LOOPER R (2) ASM.	ル-ハ° - R(2) (クミ)	1
7	#02	129-78755	FEED DOG MH(3/16") ASM.	オクリハ° MH(3/16") (クミ)	1
8		B2502-019-000	BUSHING, FRONT	ル-ハ° ジク マエメタル	1
9		SS-8151150-SP	SCREW 15/64-28 L=10.5	トメネジ° 15/64-28 L=10.5	1
10		129-68004	LOOPER SHAFT	ル-ハ° - ジク	1
11		B2123-026-0A0	FEED ROCKER ASM.	ヨート° - ウチ° クミ	1
12		SS-7111110-TP	SCREW 11/64-40 L=10.5	マルヒラネジ° 11/64-40 L=10.5	(1)
13		NS-6150310-SP	NUT 15/64-28	ロツカクナツト 15/64-28	1
14		B2505-019-0A0	CONNECTION CRANK ASM.	セ°ンゴ°カン オサエカナク° クミ	1
15		SS-7111110-TP	SCREW 11/64-40 L=10.5	マルヒラネジ° 11/64-40 L=10.5	(1)
16		B2115-191-000	FEED ROCKER CONNECTING LINK	ヨウト°ウカンレンケツウチ°	1
17	#03	B2116-019-00A	FEED CONNECTING LINK PIN	レンケツウチ°ピン	2
18	#03	B2116-019-00B	FEED CONNECTING LINK PIN	レンケツウチ°ピン	2
19		CQ-2020000-00	OIL WICK	エジソ	0.1
20		B2102-026-0A0	FEED ROCKER ASM.	ヨート° - カン クミ	1
21		SS-7090920-SP	SCREW 9/64-40 L= 8.5	マルヒラネジ° 9/64-40 L=8.5	(4)
22		SS-7080510-TP	SCREW 1/8-44 L=4.5	マルヒラネジ° 1/8-44 L=4.5	2
23		B2107-019-000	FEED ROCKER SHAFT	ヨート° - カン ジク	1
24		SS-8150710-SP	SCREW 15/64-28 L=7	トメネジ° 15/64-28 L=7	1
25		B2122-019-000	WASHER	ヨート° - カン ジク サ°カ°ネ	1
26		SS-7110830-SP	SCREW 11/64-40 L= 7.5	マルヒラネジ° 11/64-40 L=7.5	1
27		B2002-026-000-A	LOOPER AVOIDING SHAFT BRACKET	セ°ンゴ° ジクウチ°	1
28		B2503-019-000	LOOPER ROCKER SHAFT BUSHING, R	ル-ハ° ジク ウシロメタル	1
29		SS-8150310-SP	SCREW 15/64-28 L= 3.4	トメネジ° 15/64-28 L=3.4	1
30		B2003-026-000	LOOPER AVOIDING SHAFT BUSHING	セ°ンゴ° ジク メタル	1
31		SS-8150410-SP	SCREW 15/64-28 L=4	トメネジ° 15/64-28 L=4	1
32		B2006-019-0A0	LOOPER AVOIDING ECCENTRIC CAM	セ°ンゴ° オクリ ハンジンカム クミ	1
33		SS-8110410-TP	SCREW 11/64-40 L= 3.5	トメネジ° 11/64-40 L=3.5	(2)
34		B1635-191-000	SLIDE BLOCK	セ°ンゴ° カンフタマタサヤ	1
35		B2001-261-0A0	LOOPER AVOIDING SHAFT ASM.	セ°ンゴ° カンフタマタ(クミ)	1
36		SS-7111110-TP	SCREW 11/64-40 L=10.5	マルヒラネジ° 11/64-40 L=10.5	(1)
37		SS-7621040-SP	SCREW 3/16-32 L= 9.5	マルヒラネジ° 3/16-32 L=9.5	1
38		B1601-026-000	FEED BAR	スィハイ オクリ フタマタ	1
39		B1610-019-000	SLIDE BLOCK	スィハイオクリ フタマタ カクゴ°マ	(1)
40		129-62809	ADJUSTING SHAFT	ウエジタオクリリョウチョウセツジ°ク	1
41		RO-0611801-00	RUBBER RING	オリソク°	1
42		SS-8110422-TP	SCREW 11/64-40 L=4	トメネジ° 11/64-40 L=4	1
43		B2108-026-000	SLIDE BLOCK STOPPER	カクゴ° マジク° アチタ	1
44		SS-8110510-SP	SCREW 11/64-40 L=5	トメネジ° 11/64-40 L=5	1
45	#03	B2105-019-000	FEED ROCKER SLIDE BLOCK	ヨート° - カン カクゴ°マ	(1)
46	#03	B2105-019-00A	FEED ROCKER SLIDE BLOCK	ヨウト°ウカンカクゴ°マ	(1)
47		B2101-261-000-A	FEED ROCKER DRIVING LEVER	ヨウト°ウケト°ウカン	1
48		SS-7080510-TP	SCREW 1/8-44 L=4.5	マルヒラネジ° 1/8-44 L=4.5	2
49		B2103-261-0A0	FEED ECCENTRIC CAM	ケト°ウカンハンジンカム クミ	1
50		SS-8660612-TP	SCREW 1/4-40 L= 6.0	トメネジ° 1/4-40 L=6	2
51		SS-7111110-TP	SCREW 11/64-40 L=10.5	マルヒラネジ° 11/64-40 L=10.5	1
52		129-31903	BODY CAP	チョウセツタイ アチタ	1
53		129-63062	FEED ECCENTRIC BASE ASM.	オクリリョウチョウセツタイ (ソウクミ)	1
54		B1624-191-000	RATCHET PAWL	ラチエツトオサエ	(1)
55		PS-0250081-K0	SPRING PIN 2.5X8	スプリング°ピン	(1)
56		B1626-191-000	SCREW	ラチエツトオサエハ°ネ トメネジ°	(1)
57		B1625-191-000	RATCHET PAWL SPRING	ラチエツトオサエハ°ネ	(1)
58		B1623-191-000	RATCHET GEAR	ラチエツトキ°ヤ	(1)
59		129-63005	FEED ECCENTRIC	オクリリョウチョウセツタイ	(1)
60		129-31606	SCREW	オクリリョウ チョウセツタイ トメネジ°	(1)
61		129-31507	FEED ECCENTRIC BODY	スィハイオクリ チョウセツジ°ク	(1)
62		SS-8110410-TP	SCREW 11/64-40 L= 3.5	トメネジ° 11/64-40 L=3.5	(2)
63		B1621-261-000-A	FEED ECCENTRIC GUIDE	スィハイオクリカム	(1)
64		129-31705	SCREW	エルミ トメネジ°	(1)
65		B1606-191-000	FEED ECCENTRIC SLIDE BLOCK	スィハイオクリ フタマタサヤ	2
66		B1602-019-000	FEED LIFTING FORKED CONNECTION	ジ°ヨー°ケ° オクリ フタマタ	1
67		129-62601	FEED ECCENTRIC CAM	ウエジタオクリハンジンカム	1
68		SS-8660612-TP	SCREW 1/4-40 L= 6.0	トメネジ° 1/4-40 L=6	2
69		B2106-026-000	SLIDE BLOCK PIN	ケト° - カン カクゴ° マジク°	1
70		RO-0952001-00	RUBBER RING	オリソク°	1
71		SS-6122030-SP	SCREW 3/16-28 L=20	ヒラネジ° 3/16-28 L=20	2

Note (注記) #01...FOR MS-1261

REFER TO THE TABLE OF EXCHANGING PARTS ON P.23

#02...FOR MS-1260

REFER TO THE TABLE OF EXCHANGING PARTS ON P.23

#03...SELECTIVE PART

MS-1261 用

23 ページの交換部品一覧表を  
ご参照下さい。

MS-1260 用

23 ページの交換部品一覧表を  
ご参照下さい。

選択部品

# 6. LOOPER & FEED DOG COMPONENTS

ルーパ・送り歯関係

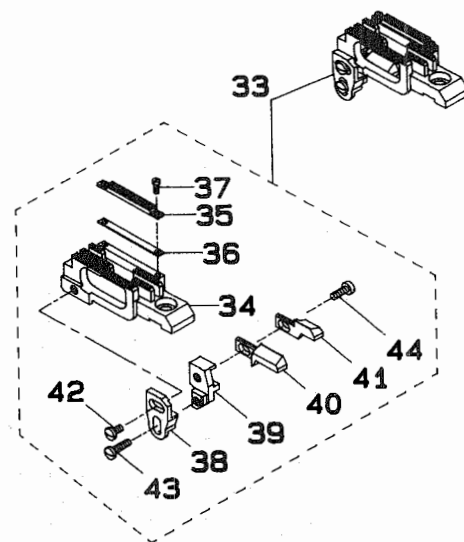
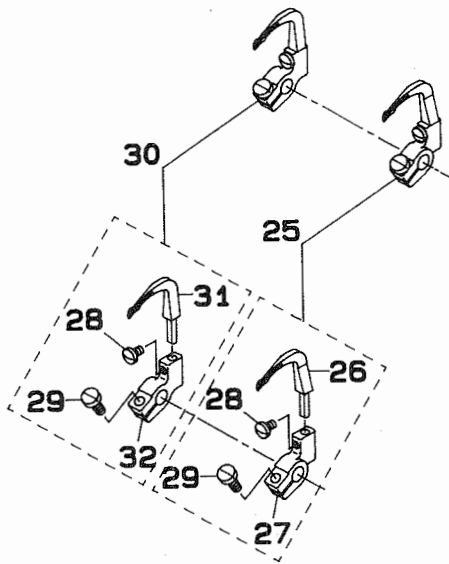
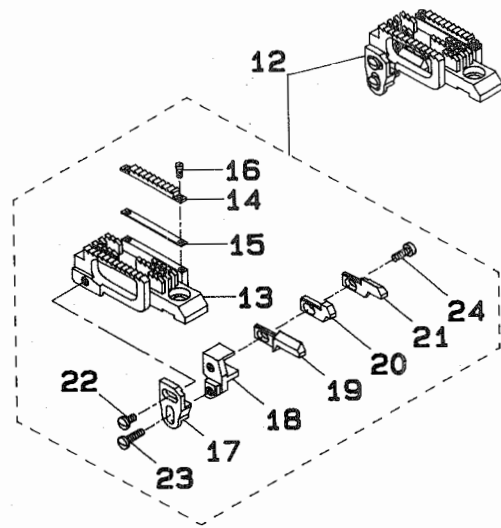
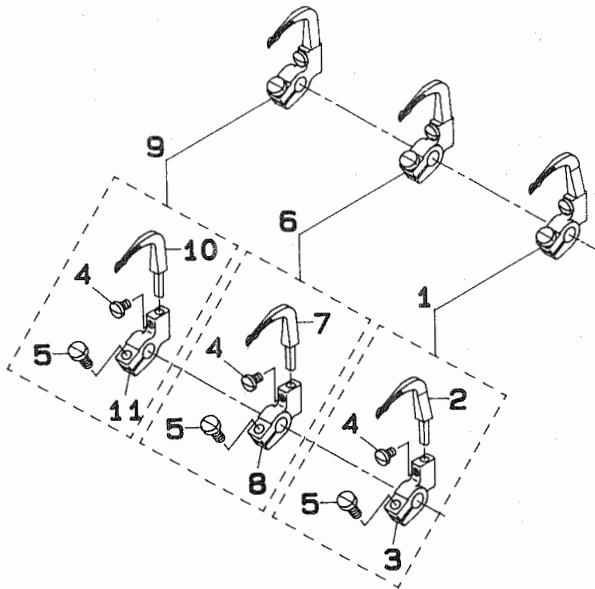

REF.NO	NOTE	PART NO.	DESCRIPTION	ヒンメイ	Qty
1	#01	129-68558	LOOPER L (1) ASM.	ル-ハ° - L(1) (クミ)	1
2		129-68509	LOOPER L (1)	ル-ハ° - L(1)	(1)
3		129-42009	LOOPER HOLDER, 2	ル-ハ° - シジ°ウテ° (2)	(1)
4		SS-7080510-TP	SCREW 1/8-44 L=4.5	マルヒラネジ° 1/8-44 L=4.5	(3)
5		SS-6090910-TP	SCREW 9/64-40 L=9	ヒラネジ° 9/64-40 L=9	(3)
6	#01	129-68855	LOOPER R (1) ASM.	ル-ハ° - R(1) (クミ)	1
7		129-68806	LOOPER R (1)	ル-ハ° - R(1)	(1)
8		129-69309	LOOPER HOLDER (3)	ル-ハ° - シジ°ウテ° (3)	(1)
9	#01	129-69150	LOOPER C (1) ASM.	ル-ハ° - C(1) (クミ)	1
10		129-69101	LOOPER C (1)	ル-ハ° - C(1)	(1)
11		129-41100	LOOPER HOLDER, 1	ル-ハ° - シジ°ウテ° (1)	(1)
12	#01	129-63351	FEED DOG XH(1/4") ASM.	オクリハ° XH(1/4") (クミ)	1
13		129-63302	FEED DOG XH(1/4")	オクリハ° XH(1/4")	(1)
14		129-64201	ADJUSTING FEED DOG XH	チョウセツオクリハ° XH	(1)
15		129-64102	FEED DOG ADJUSTING PLATE (A)	オクリハ° チョウセツイタ (A)	(1)
16		129-64300	ADJUSTING FEED DOG SETSCREW	チョウセツオクリハ° トメネジ°	(2)
17		129-64409	NEEDLE HOLDER ADJUSTING BASE	ハリウケ チョウセツタイ	(1)
18		129-64805	NEEDLE HOLDER (A)	ハリウケ シジ°タイ (A)	(1)
19		129-64508	NEEDLE HOLDER (LEFT)	ハリウケ (ヒタ°リ)	(1)
20		129-64607	NEEDLE HOLDER (INSIDE)	ハリウケ (ナカ)	(1)
21		129-64706	NEEDLE HOLDER (RIGHT)	ハリウケ (ミキ°)	(1)
22		SS-7090510-SP	SCREW 9/64-40 L= 4.6	マルヒラネジ° 9/64-40 L=4.6	(1)
23		SS-7091110-TP	SCREW 9/64-40 L=10.5	マルヒラネジ° 9/64-40 L=10.5	(1)
24		SS-6090910-TP	SCREW 9/64-40 L=9	ヒラネジ° 9/64-40 L=9	(1)
25	#02	129-79258	LOOPER L (3) ASM.	ル-ハ° - L(3) (クミ)	1
26		129-79209	LOOPER L (3)	ル-ハ° - L(3)	(1)
27		129-42009	LOOPER HOLDER, 2	ル-ハ° - シジ°ウテ° (2)	(1)
28		SS-7080510-TP	SCREW 1/8-44 L=4.5	マルヒラネジ° 1/8-44 L=4.5	(2)
29		SS-6090910-TP	SCREW 9/64-40 L=9	ヒラネジ° 9/64-40 L=9	(2)
30	#02	129-79357	LOOPER R (2) ASM.	ル-ハ° - R(2) (クミ)	1
31		129-79308	LOOPER C (2)	ル-ハ° - C(2)	(1)
32		129-41100	LOOPER HOLDER, 1	ル-ハ° - シジ°ウテ° (1)	(1)
33	#02	129-78755	FEED DOG MH(3/16") ASM.	オクリハ° MH(3/16") (クミ)	1
34		129-78706	FEED DOG MH(3/16")	オクリハ° MH(3/16")	(1)
35		129-75504	ADJUSTING FEED DOG MH	チョウセツオクリハ° MH	(1)
36		129-64102	FEED DOG ADJUSTING PLATE (A)	オクリハ° チョウセツイタ (A)	(1)
37		129-64300	ADJUSTING FEED DOG SETSCREW	チョウセツオクリハ° トメネジ°	(2)
38		129-64409	NEEDLE HOLDER ADJUSTING BASE	ハリウケ チョウセツタイ	(1)
39		129-79001	NEEDLE HOLDER (B)	ハリウケ シジ°タイ (B)	(1)
40		129-78805	NEEDLE HOLDER (LEFT)	ハリウケ (ヒタ°リ)	(1)
41		129-78904	NEEDLE HOLDER (RIGHT)	ハリウケ (ミキ°)	(1)
42		SS-7090510-SP	SCREW 9/64-40 L= 4.6	マルヒラネジ° 9/64-40 L=4.6	(1)
43		SS-7091110-TP	SCREW 9/64-40 L=10.5	マルヒラネジ° 9/64-40 L=10.5	(1)
44		SS-6090670-TP	SCREW 9/64-40 L=6	ヒラネジ° 9/64-40 L=6	(1)

Note (注記) #01...FOR MS-1261  
REFER TO THE TABLE OF EXCHANGING PARTS ON P.23  
#02...FOR MS-1260  
REFER TO THE TABLE OF EXCHANGING PARTS ON P.23

MS-1261 用  
23 ページの交換部品一覧表を  
ご参照下さい。  
MS-1260 用  
23 ページの交換部品一覧表を  
ご参照下さい。

# 7. KNEE LIFTER COMPONENTS

膝上げ関係

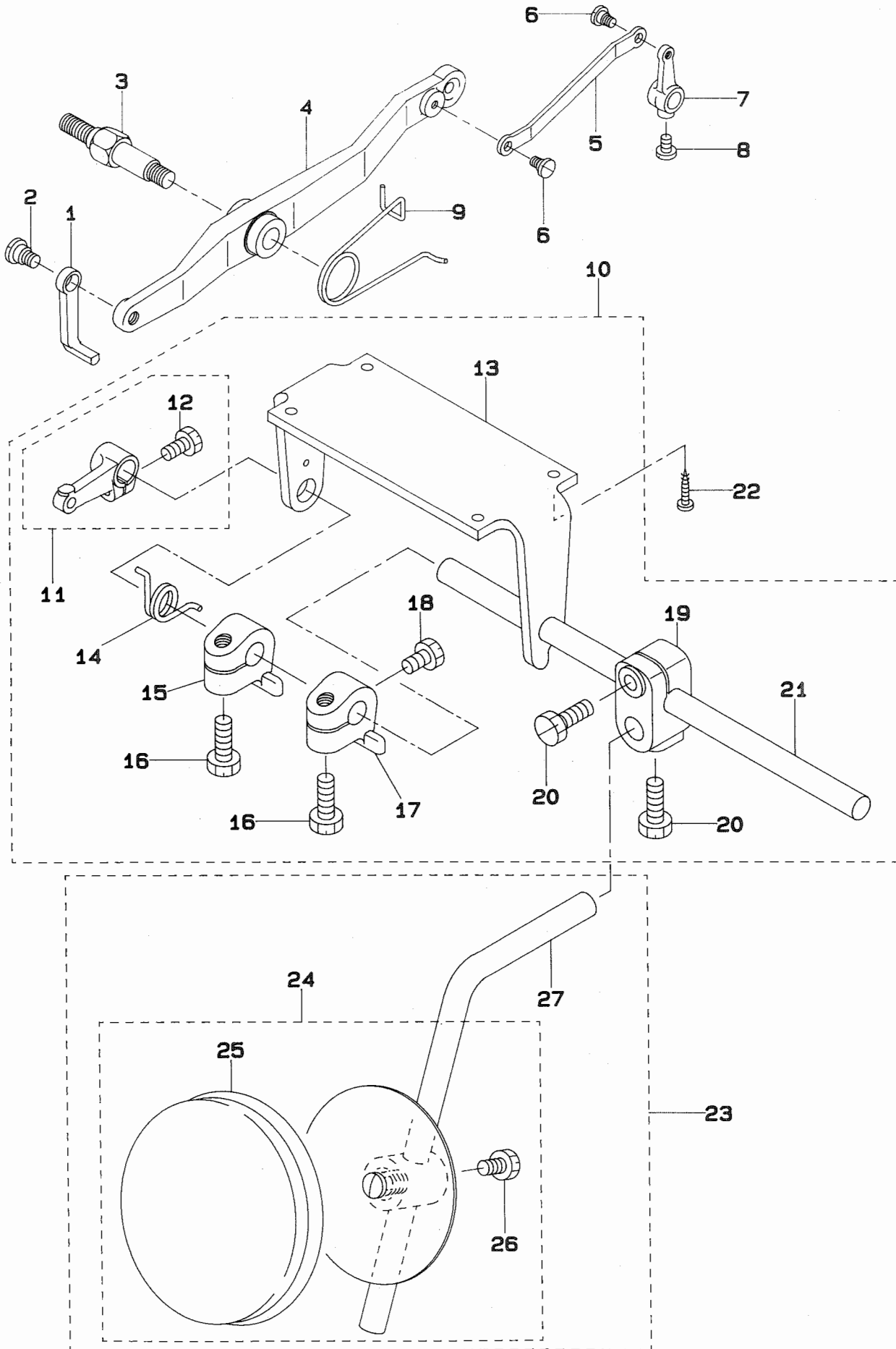



REF.NO	NOTE	PART NO.	DESCRIPTION	ヒソメイ	Qty
1		B2322-019-000	PRESSER BAR LIFTING BRACKET LI	オサエアケテコ	1
2		SD-0790431-SP	HINGE SCREW D= 7.94 H= 4.3	タソソネジ D=7.94 H=4.3	1
3		B3701-019-000	HINGE SCREW	ヒサアケテコ タソソネジ	1
4		B2319-191-00A	PRESSER BAR LIFTING LEVER	ヒサアケテコ	1
5		B2315-019-000	TENSION RELEASING CONNECTING L	イトユルメ レハ-	1
6		SD-0450211-SP	HINGE SCREW D= 4.50 H= 2.1	タソソネジ D=4.5 H=2.1	2
7		B2317-019-000	TENSION RELEASING SHAFT CRANK	イトユルメ ウテ	1
8		SS-7110710-SP	SCREW 11/64-40 L=7	マルヒラネジ 11/64-40 L=7	1
9		B2321-019-000	PRESSER BAR LIFTING LEVER SPRI	ヒサアケテコ ハネ	1
10		B8101-191-0A0	KNEE LIFTER ASM.	ヒサアケソチ トリツケダイ クミ	1
11		B8102-191-0A0	KNEE LIFTER LEVER ASM.	ヒサアケレハ- クミ	(1)
12		SS-9151210-TP	SCREW 15/64-28 L=11.8	ロツカクホルト 15/64-28	(1)
13		B8101-191-000	KNEE DRIVING SHAFT MOUNTING	ヒサアケソチ トリツケダイ	(1)
14		B8511-180-000	SPRING	ヒサアケ ハネ	(1)
15		B3426-122-000	KNEE PRESS ROD THRUST BLOCK	ヒサアケ カイテントメ	(1)
16		SS-9182010-SN	SCREW 9/32-20 L=20	ロツカクホルト 9/32-20 L=20	(2)
17		B8514-180-000	STOP BLOCK	ネジツキ ストツハ-	(1)
18		SS-9661120-CP	SCREW 1/4-40 L=10.5	ロツカクホルト 1/4-40 L=10.5	(1)
19		B3427-122-000	KNEE PRESS ROD MOUNTING BRACKE	ヒサアテ タテジク トリツケウテ	(1)
20		SS-9182010-SN	SCREW 9/32-20 L=20	ロツカクホルト 9/32-20 L=20	(2)
21		B3421-012-000	KNEE PRESS ROD	ヒサアテ ヨコジク	(1)
22		SK-3482500-SC	WOOD SCREW D=4.8 L=25	マルモクネジ D=4.8 L=25	4
23		B3419-552-0A0-A	KNEE LIFTER PLATE ROD ASM.	ヒサアテ タテジク クミ	1
24		B3430-552-0A0	KNEE PRESS PLATE ASM.	ヒサアテイタ クミ	(1)
25		B3431-552-000-A	KNEE PRESS PLATE COVER	ヒサアテイタ カハ-	(1)
26		SS-9661120-CP	SCREW 1/4-40 L=10.5	ロツカクホルト 1/4-40 L=10.5	(1)
27		B3419-122-000	KNEE LIFTER PLATE ROD	ヒサアテ タテジク	(1)

# 8. THREAD STAND COMPONENTS

糸立装置関係

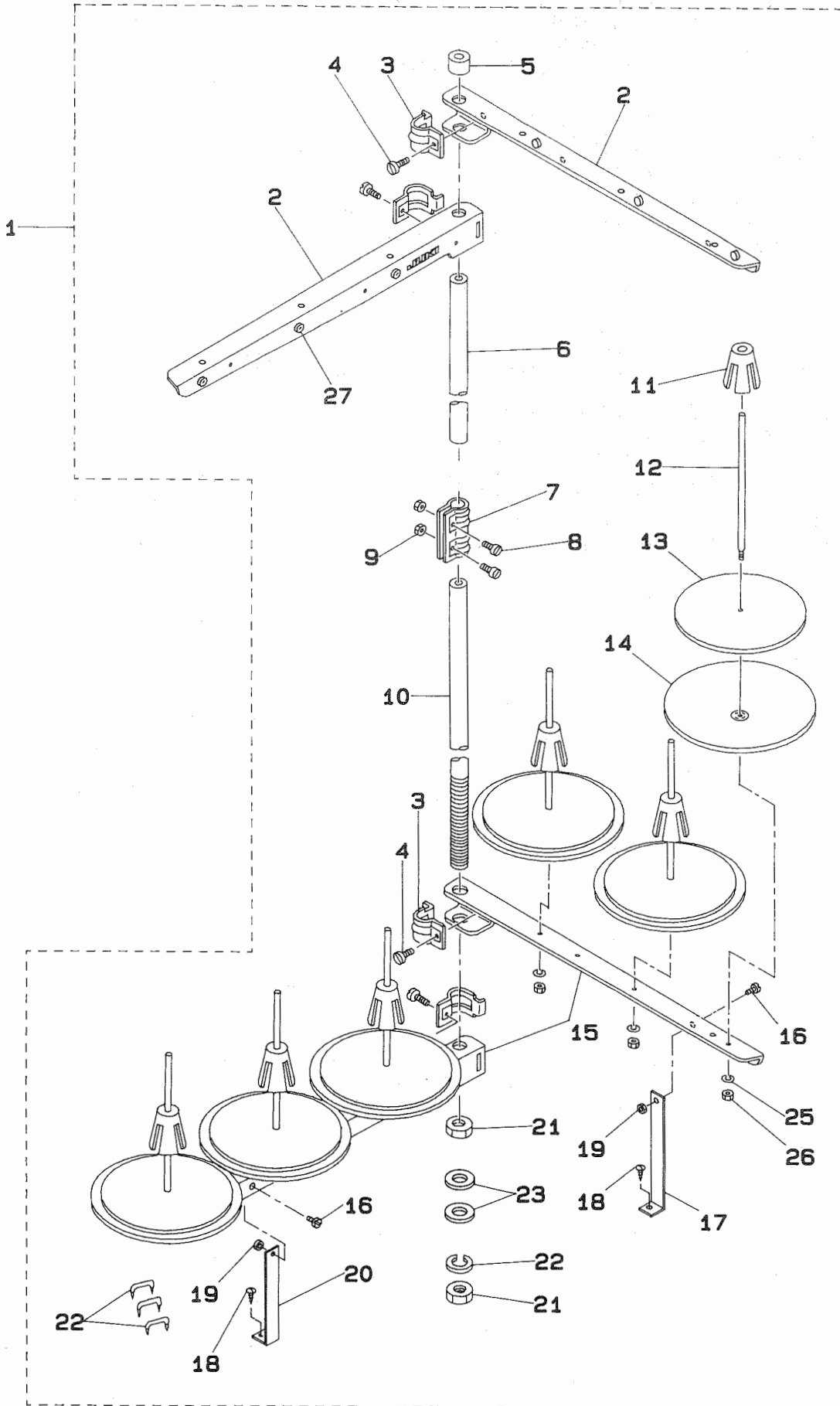

REF.NO	NOTE	PART NO.	DESCRIPTION	ヒンメイ	Qty
1		B3301-026-LAA	THREAD STAND ASM.	イトタテソウチ(クミ)	1
2		119-57602	THREAD GUIDE ARM, A	イトタテウテ (A)	(2)
3		B3318-704-L00	THREAD GUIDE ARM JOINT	イトタテイトアンナイ シメカナク	(4)
4		SM-6061200-SE	SCREW M6 L=12	ヒラコネジ M6 L=12	(4)
5		111-84108	SPOOL REST ROD RUBBER CAP	イトタテホウ ホコゴム	(1)
6		119-57503	SPOOL REST ROD, UPPER	イトタテホウ (ウエ)	(1)
7		111-84207	SPOOL REST ROD JOINT	イトタテホウ ツナキテ	(1)
8		SM-4051405-SE	SCREW M5X0.8 L=14	ナベコネジ M5X0.8 L=14	(2)
9		NM-6050001-SE	NUT M5X0.8	ロツカクナツト M5X0.8 1シュ	(2)
10		119-57404	SPOOL REST ROD, LOWER	イトタテホウ (シタ)	(1)
11		111-84009	SPOOL RETAINER	イトマキ フルトメ	(6)
12		B3320-704-L00	SPOOL PIN	イトマキウケホ-	(6)
13		B3311-012-000	SPOOL REST CUSHION	イトマキウケサ-	(6)
14		111-83902	SPOOL REST	イトマキ ウケサラ	(6)
15		119-57602	THREAD GUIDE ARM, A	イトタテウテ (A)	(2)
16		SM-4061201-SE	SCREW M6 L=12	ナベコネジ M6 L=12	(2)
17		B3321-704-LOB	SPOOL REST ARM SUPPORT, B	イトタテウテササエ B	(1)
18		SK-3382001-SE	SCREW D=3.8 L=20	マルモコネジ D=3.8 L=20	(2)
19		NM-6060001-SE	NUT M6	ロツカクナツト M6 1シュ	(2)
20		B3321-704-L00	SPOOL REST ARM SUPPORT, A	イトタテウテササエ A	(1)
21		B3317-704-000	NUT C15	イトタテホ- トメナツト	(2)
22		WS-1643202-KR	SPRING WASHER	ハネサカネ 16.4X26.6X3.2	(1)
23		WP-1702600-S0	WASHER 17X30X2.6	ヒラサカネ 17X30X2.6	(2)
24		MAO-11532000	CORD STAPLE	コート ステツプル	(3)
25		WS-0510002-KN	SPRING WASHER	ハネサカネ 5.1X9.2X1.3	(6)
26		NM-6050001-SE	NUT M5X0.8	ロツカクナツト M5X0.8 1シュ	(6)
27		B3319-704-L00	THREAD GUIDE	イトミチ	(6)

9. FRAME & COVER COMPONENTS

フレーム・カバー関係

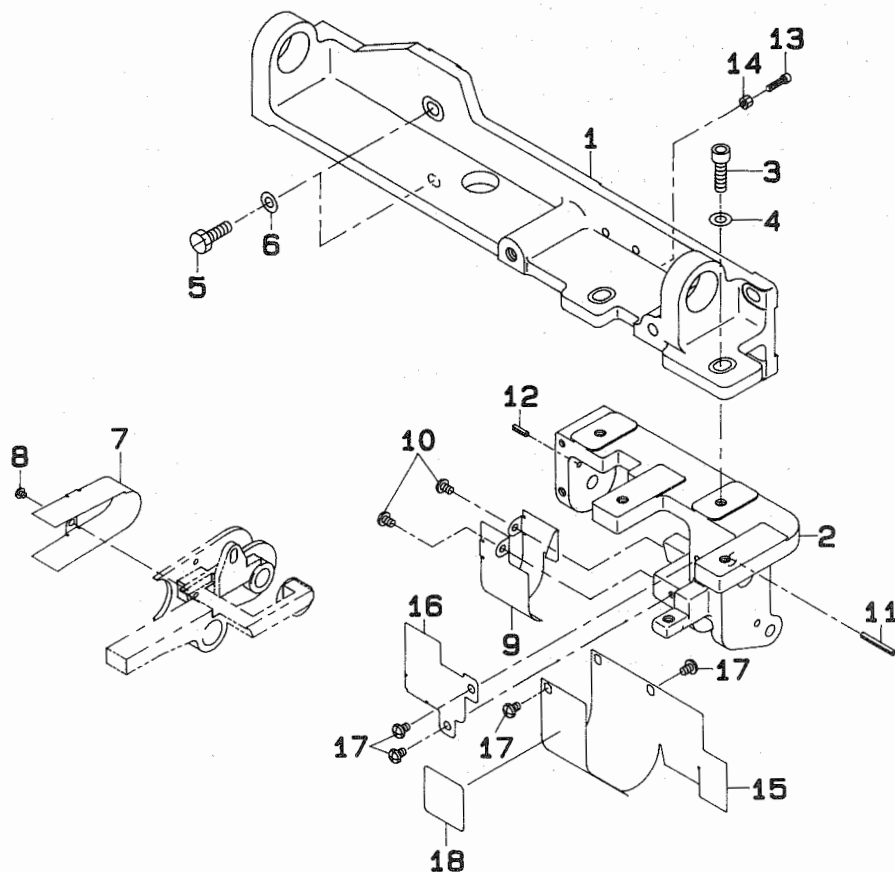

REF.NO	NOTE	PART NO.	DESCRIPTION	ヒ ン メ イ	Qty
1		MAV-04501000	MAIN BASE	メインベース	1
2		MAV-04502000	CLUTCH BASE	クラッチベース	1
3		SM-6062002-TP	SCREW M6 L=20	ロツカクアナボルト M6 L=20	2
4		WP-0641600-SC	WASHEW 6.4X12.5X1.6	ヒラサカネ	2
5		SM-9061850-SC	SCREW M6 L=18	ロツカクボルト M6 L=18	4
6		WP-0641600-SC	WASHEW 6.4X12.5X1.6	ヒラサカネ	4
7		MAV-04503000	ROLLER COVER	ローラーカバー	1
8		SM-5030355-SE	SCREW	ハイントネジ	2
9		MAV-04504000	INTERMEDIATE PULLEY COVER	チュークンブリーカバー	1
10		SM-5040655-SN	SCREW	ハイントネジ	3
11		PS-0300242-KO	SPRING PIN 3.0X24	スプリングピン 3.0X24	1
12		PS-0300102-KO	SPRING PIN 3.0X10	スプリングピン 3.0X10	1
13		SM-6031202-TP	SCREW M3X0.5 L=12	ロツカクナット	1
14		NM-6030003-SC	NUT	ロツカクナット M3X0.5 3シユ	1
15		MAV-04505000	CLUTCH COVER A	クラッチカバー A	1
16		MAV-04506000	CLUTCH COVER B	クラッチカバー B	1
17		SM-5040655-SN	SCREW	ハイントネジ	5
18		MAV-04507000	MODEL PLATE	モデルメIH	1

10. DRIVE COMPONENTS

駆動関係

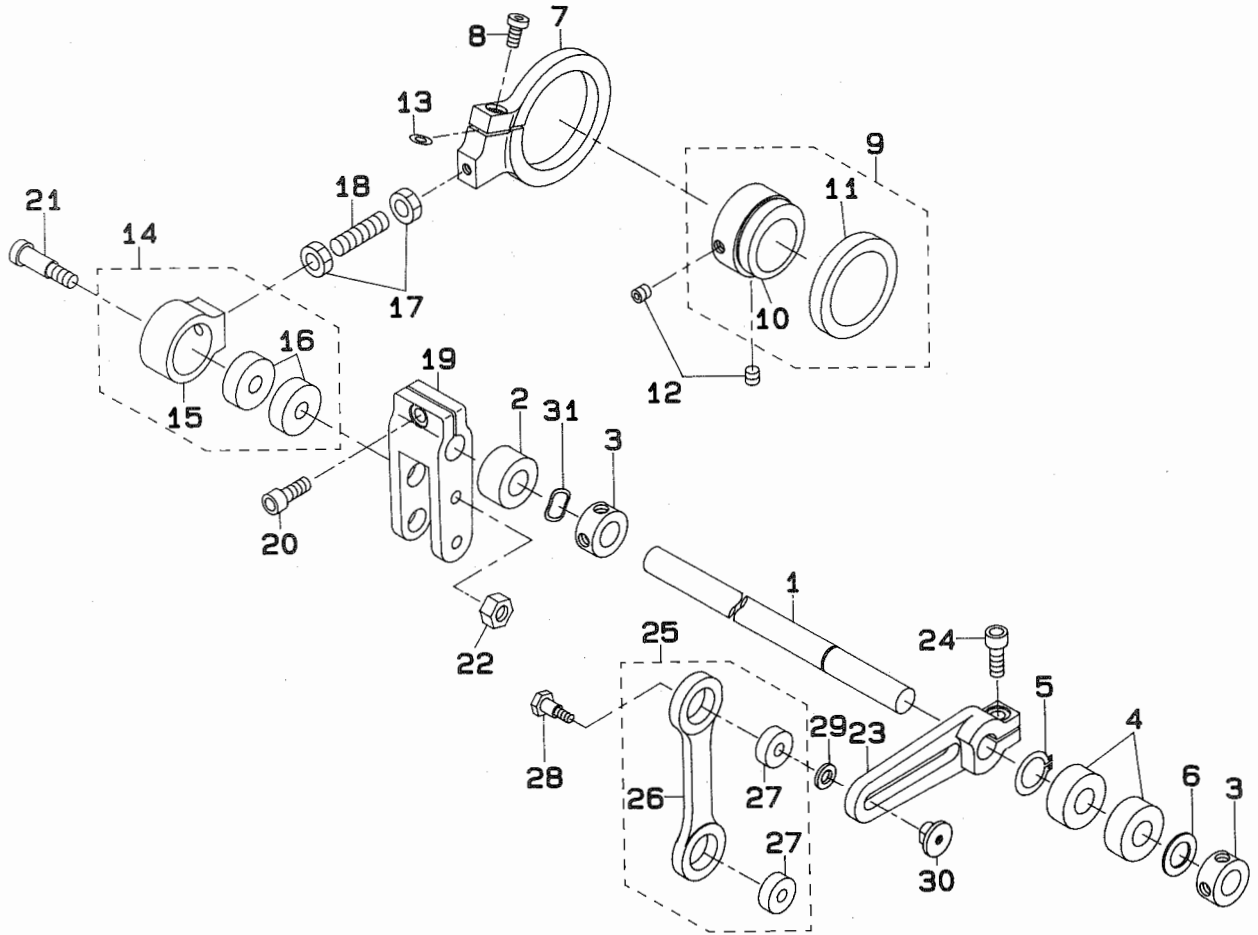

REF.NO	NOTE	PART NO.	DESCRIPTION	ヒンメイ	Qty
1		MAV-04515000	ROCKING SHAFT	ヨウトウシャフト	1
2		SB-2120001-00	BEARING	コロカリスシクウケ	1
3		CS-1201010-SH	THRUST COLLAR ASM. D=12 W=10	スラストウケ D=12 W=10 クミ	2
4		SB-1120005-00	BEARING	コロカリスシクウケ	2
5		RC-1200001-KP	C-SHAPED SNAP RING	Cカクタメジ	1
6		WP-1221016-SP	WASHER	ヒラチカネ	1
7		MAV-04516000	ROCKING CRANK	ヨウトウクラク	1
8		SM-6051002-TP	SCREW M5X0.8 L=10	ロツカクアナボルト M5X0.8 L=10	1
9		MAV-045170A0	ECCENTRIC SHAFT ASM.	ハンジンシク (クミ)	1
10		MAV-045170Q0	ECCENTRIC SHAFT	ハンジンシク	(1)
11		SB-1350003-00	BEARING	コロカリスシクウケ	(1)
12		SM-8060602-TP	SCREW M6X6	トメネジ M6 L=6	2
13		WP-0841601-SC	WASHER 8.4X17.4X1.6	ヒラチカネ ミカキマル M8	1
14		MAV-045180A0	ROCKING CRANK HOUSING ASM.	ヨウトウクラクハウジング クミ	1
15		MAV-045180Q0	ROCKING CRANK HOUSING	ヨウトウクラクハウジング	(1)
16		SB-1080006-00	BEARING	コロカリスシクウケ	(2)
17		NM-6080003-SC	NUT M8	ロツカクナツト M8 3シュ	2
18		SM-8082502-TP	SCREW	トメネジ	1
19		MAV-04519000	ROCKING ROD	ヨウトウロツト	1
20		SM-6061602-TP	SCREW M6 L=16	ロツカクアナボルト	1
21		SD-0801606-SH	STEP-SCREW	タンネジ	1
22		NM-6060003-SC	NUT M6	ロツカクナツト M6 3シュ	1
23		MAV-04520000	ADJUSTING ROD	アジャストロツト	1
24		SM-6061602-TP	SCREW M6 L=16	ロツカクアナボルト	1
25		MAV-045210A0	JOINT ROD ASM.	ジョイントロツト (クミ)	1
26		MAV-045210Q0	JOINT ROD	ジョイントロツト	(1)
27		SB-1060002-00	BEARING 6X17	ヘアリング 6X17	(2)
28		SD-0600756-TP	STEP-SCREW	タンネジ	1
29		WP-0641600-SC	WASHER 6.4X12.5X1.6	ヒラチカネ	1
30		MAV-045220Q0	ADJUSTING PIN	アジャストピン	1
31		WZ-1200200-KP	WAVED WASHER	ナミカタチカネ	1

# 11. CLUTCH COMPONENTS

## クラッチ関係

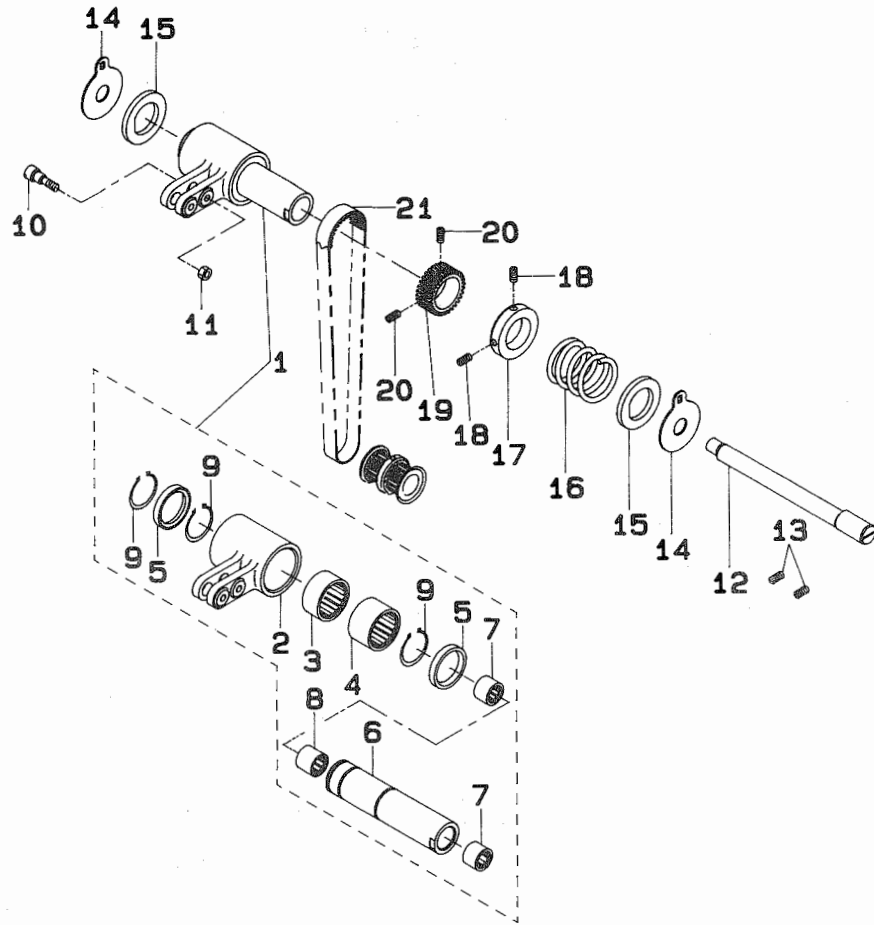

REF.NO	NOTE	PART NO.	DESCRIPTION	ヒンメイ	Qty
1		MAV-045250A0	CLUTCH CASE ASM.	クラッチケース クミ	1
2		MAV-04525000	CLUTCH CASE	クラッチケース	(1)
3		SB-3200003-00	BALL BEARING	ゴロカ"リジ"クウケ	(1)
4		SB-3200004-00	BALL BEARING	ゴロカ"リジ"クウケ	(1)
5		MAV-04534000	CLUTCH OIL SHIELD	クラッチオイルシールド	(2)
6		MAV-04526000	CLUTCH ROCKING SHAFT	クラッチヨウト"クシ"ク	(1)
7		SB-3100003-00	BALL BEARING	ゴロカ"リジ"クウケ	(2)
8		SB-3100007-00	BALL BEARING	ゴロカ"リジ"クウケ	(1)
9		RC-1851217-KP	C-RING	Cカ"タメ"リ	(3)
10		SD-0600596-SH	STEP-SCREW	タ"ンネ"ジ"	1
11		NM-6040003-SC	NUT M4	ロツカクナツト M4X0.7 3ｼ"ユ	1
12		MAV-04527000	CLUTCH SHAFT	クラッチシャフト	1
13		SM-8050602-TP	SCREW M5 L=6	トメネ"ジ" M5X0.8 L=6	2
14		MAV-04528000	BRAKE PLATE	ブ"レ"キイ"タ	2
15		MAV-04529000	BRAKE WASHER	ブ"レ"キワッ"シャ	2
16		MAV-04530000	BRAKE SPRING	ブ"ー"キハ"ネ	1
17		MAV-04531000	CLUTCH BRAKE COLLER	クラッチブ"レ"キカラ"ー	1
18		SM-8040602-TP	SCREW M4X0.7 L=6	トメネ"ジ" M4X0.7 L=6	2
19		MAV-04532000	CLUTCH PULLEY	クラッチプ"ー"リ"ー	1
20		SM-8040302-TP	SETScrew	トメネ"ジ" M4X0.7 L=2	2
21		MAV-04533000	CLUTCH TIMING BELT	クラッチタイミン"ク"ベ"ルト	1

## 12. ROLLER DRIVE COMPONENTS

### ローラー駆動関係

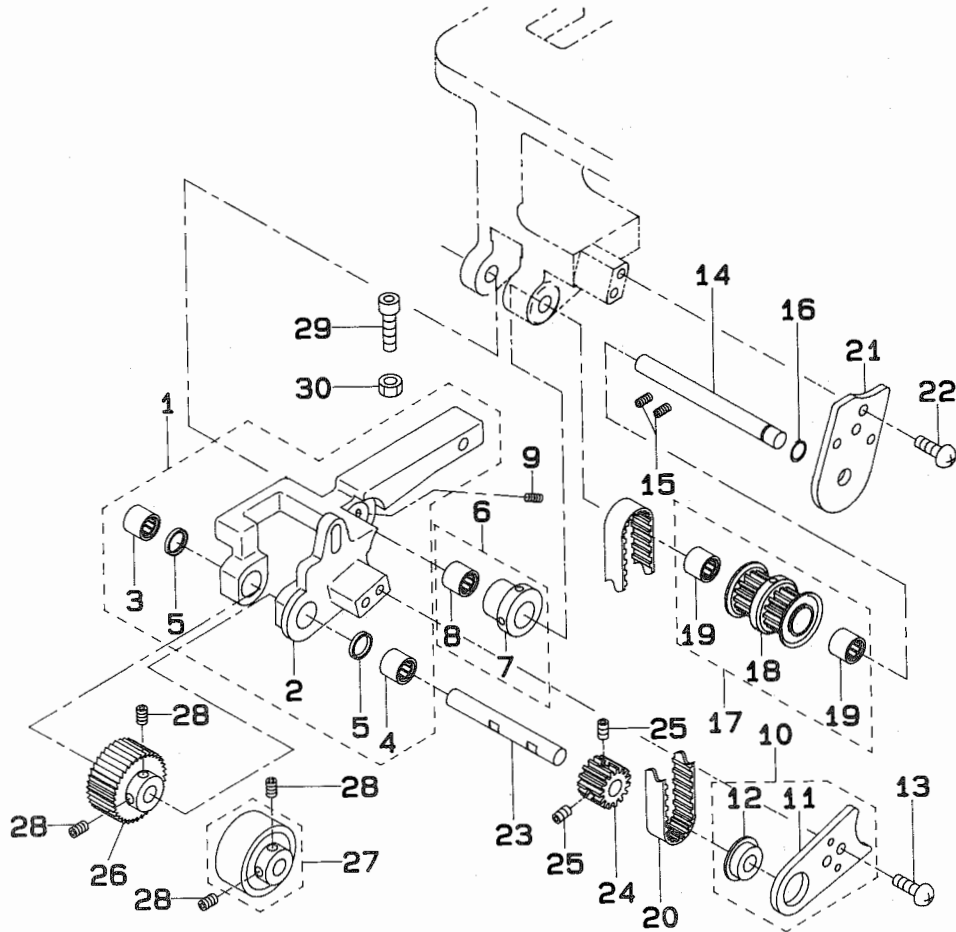

REF.NO	NOTE	PART NO.	DESCRIPTION	ヒ ン メ イ	Qty
1		MAV-045350A0	ROLLER BASE ASM.	ローラーベース クミ	1
2		MAV-04535000	ROLLER BASE	ローラーベース	(1)
3		SB-3070005-00	BEARING	コロカブリシクウケ	(1)
4		SB-3070004-00	BEARING	コロカブリシクウケ	(1)
5		MAV-04546000	ROLLER SHAFT OIL SHIELD	ローラーシャフトオイルシールド	(2)
6		MAV-045360A0	ECCENTRIC COLLER ASM.	ローラーベースハンジンカラー クミ	1
7		MAV-04536000	ROLLER BASE ECCENTRIC COLLER	ローラーベースハンジンカラー	(1)
8		SB-3070004-00	BEARING	コロカブリシクウケ	(1)
9		SM-8040402-TP	SCREW M4X0.7 L=4	トメネジ M4X0.7 L=4	1
10		MAV-045470A0	ROLLER SHAFT PLATE ASM.	ローラーシャフトプレート クミ	1
11		MAV-04547000	ROLLER SHAFT PLATE	ローラーシャフトプレート	(1)
12		SB-1070001-00	BEARING	コロカブリシクウケ	(1)
13		SM-6040802-TP	SCREW M4X0.7 L=8	ロツカクアナボルト	2
14		MAV-04537000	PULLEY SHAFT	プーリーシャフト	1
15		SM-8050502-TP	SCREW M5 L=5	トメネジ	2
16		RC-0650811-KP	RETAINING RING	Cカクタメワ	1
17		MAV-045380B0	INTERMEDIATE PULLEY ASM.	チユウカンプーリー ソウクミ	1
18		MAV-045380A0	INTERMEDIATE PULLEY ASM.	チユウカンプーリー (クミ)	(1)
19		SB-3070004-00	BEARING	コロカブリシクウケ	(2)
20		MAV-04541000	ROLLER TIMING BELT	ローラータイミンクベルト	1
21		MAV-04542000	SUPPORT PLATE	サポートプレート	1
22		SM-6040802-TP	SCREW M4X0.7 L=8	ロツカクアナボルト	2
23		MAV-04543000	ROLLER SHAFT	ローラーシャフト	1
24		MAV-04544000	ROLLER PULLEY	ローラープーリー	1
25		SM-8040602-TP	SCREW M4X0.7 L=6	トメネジ	2
26	#01	MAV-04545000	STEEL ROLLER	スチールローラー (クサビカクタ)	1
27	#01	MAV-045500A0	URETHANE ROLLER ASM.	ウレタンローラー (クミ)	1
28		SM-8040402-TP	SCREW M4X0.7 L=4	トメネジ M4X0.7 L=4	2
29		SM-6062002-TP	SCREW M6 L=20	ロツカクアナボルト M6 L=20	1
30		NM-6060003-SC	NUT M6	ロツカクナット M6 3シ	1

Note (注記) #01...SELECTIVE PART

選択部品

# 13. PRESSER COMPONENTS

押さえ関係

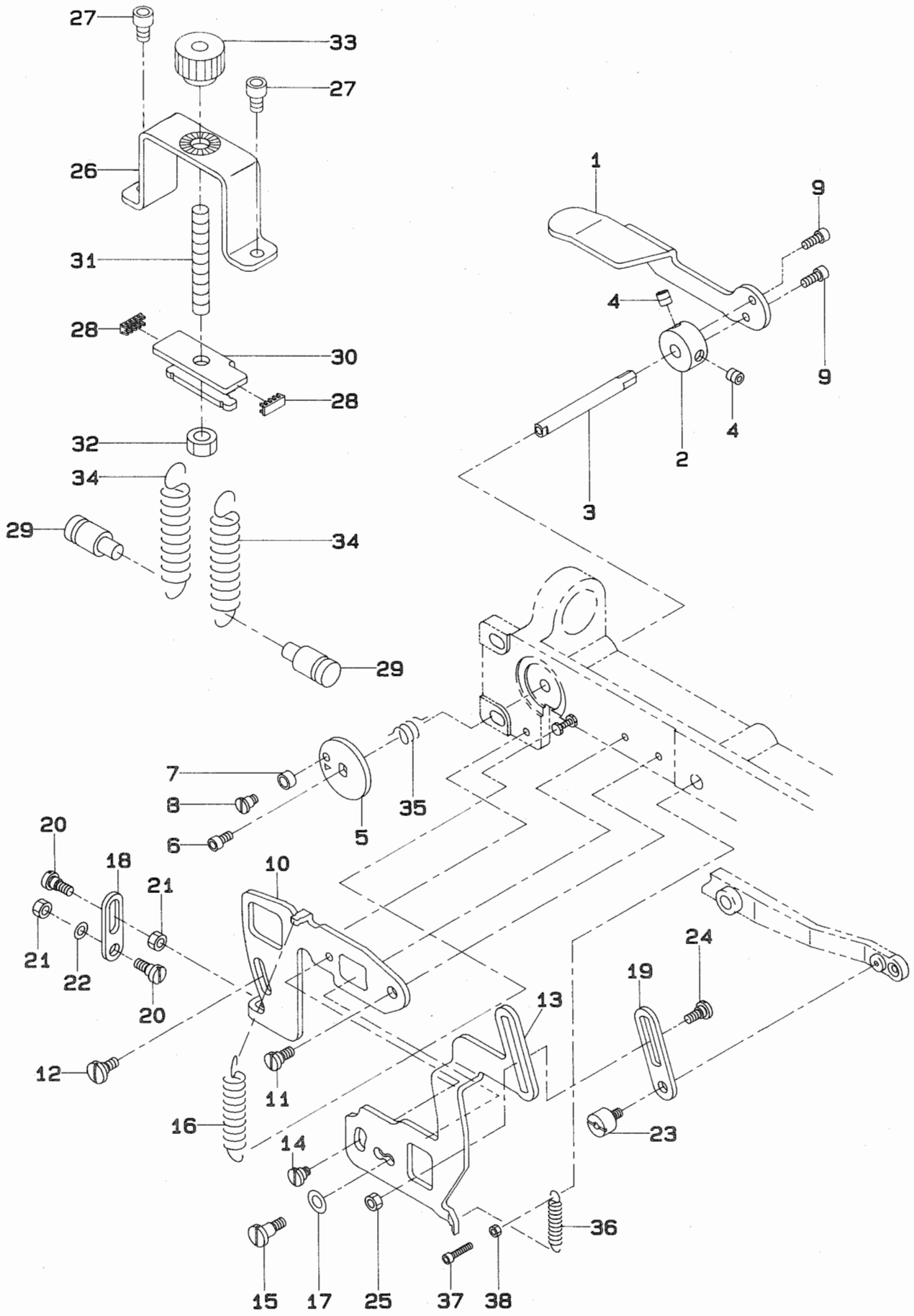





REF.NO	NOTE	PART NO.	DESCRIPTION	ヒ ン メ イ	Qty
1		MAV-04555000	PRESSER LIFTING LEVER	オサエアケレハ	1
2		MAV-04556000	PRESSER LIFTING LEVER COLLER	オサエアケレハカ	1
3		MAV-04557000	PRESSER LIFTING SHAFT	オサエアケシク	1
4		SM-8060602-TP	SCREW M6X6	トメネシ M6 L=6	2
5		MAV-04558000	PRESSER LIFTING CAM PLATE	オサエアケカムイタ	1
6		SM-6040802-TP	SCREW M4X0.7 L=8	ロツカクアナホルト	1
7		D2587-L8W-B00	ROLLER	クトカム コロ	1
8		SD-0550451-SP	HINGE SCREW	タネネシ	1
9		SM-6041002-TP	SCREW M4 L=10	ロツカクアナホルト M4X0.7 L=10	2
10		MAV-04559000	PRESSER LIFTING PLATE	オサエアケプレート	1
11		SD-0640325-SP	HINGE SCREW	タネネシ	1
12		SD-0600361-SP	HINGE SCREW	タネネシ	1
13		MAV-04560000	PRESSER LIFTING JOINT PLATE	オサエアケジョイントプレート	1
14		SD-0640321-TP	HINGE SCREW	タネネシ	1
15		SD-0640751-SP	HINGE SCREW D= 6.35 H= 7.5	タネネシ D=6.35 H=7.5	1
16		B2056-781-000	BLOCKING ARM SPRING	ソウテハネ	1
17		WP-0651056-SH	WASHER 6.5X11X1	ヒラサカネ 6.5X11X1	1
18		MAV-04561000	PRESSER LIFTING ROD	オサエアケロッド	1
19		MAV-04616000	PRESSER LIFTING LINK	オサエアケリンク	1
20		SD-0600402-TP	HINGE SCREW D= 6 H= 4	タネネシ D=6 H=4	2
21		NS-6620310-SP	NUT 3/16-32	ロツカクナツト 3/16-32	2
22		WP-0480856-SP	WASHER 4.8X8.4X0.8	ヒラサカネ 4.8X8.4X0.8	1
23		MAV-04562000	KNEE LIFTER LEVER COLLER	ヒサアケテコカ	1
24		SD-0600271-SP	HINGE SCREW D= 6 H= 2.7	タネネシ D=6 H=2.7	1
25		NS-6110430-SP	NUT 11/64-40	ロツカクナツト 11/64-40	1
26		MAV-04564000	PRESSER LIFTING BASE	オサエアケベース	1
27		SM-6061002-TP	SCREW M6 L=10	ロツカクアナホルト M6 L=10	2
28		MAV-04565000	SPRING PLATE COVER	ハネプレートカバー	2
29		B1506-352-000	TENSION SPRING RACK B	ヒツハリ ハネカケ B	2
30		MAV-04566000	SPRING PLATE	ハネプレート	1
31		MAV-04567000	PRESSER ADJUSTING SCREW	オサエアケセツネシ	1
32		NM-6080001-SC	NUT M8X1.25	ロツカクナツト M8 1.25	1
33		MAV-04568000	PRESSER ADJUSTING KNOB	オサエアケセツツマミ	1
34		MAV-04569000	PRESSER SPRING	オサエハネ	2
35		MAV-04563000	PRESSER LIFTING LEVER SPRING	オサエアケレハハネ	1
36		135-15606	SPRING	イトキリ ホシヨカム モトシハネ	1
37		SM-6031402-TP	SCREW	ロツカクアナホルト	1
38		NM-6030003-SC	NUT	ロツカクナツト M3X0.5 3.0	1

14. TABLE OF EXCHANGING GAUGE PARTS

交換ゲージ一覧表

MS-1261/V045 (For Extra heavy-weight)

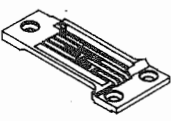
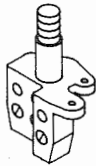
MS-1261/V045 (極厚物用)

		1	2	3	4	5	
Description 品名		Gauge set	Gauge set (with finger guard)	Throat plate	Needle clamp asm.	Presser foot asm.	
		ゲージセット	ゲージセット (指ガード付)	針板	針留(組)	押さえ(組)	
Needle gauge size 針幅	Code ゲージ 記号						
							inch
E	7/32	5.6	12953352	12953360	12953303	12956355	12960159
F	1/4	6.4	12953253	12953261	12953204	12956256	12960050
G	9/32	7.2	12953451	12953469	12953402	12956454	12960258
H	5/16	8.0	12953550	12953568	12953501	12956553	12960357
K	3/8	9.5	12953659	12953667	12953600	12956652	12960456

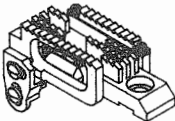
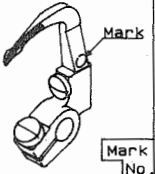
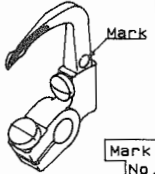
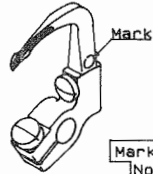

		6	7	8	9	10				
Description 品名		Presser foot asm. (with finger guard)	Feed dog asm.	Looper asm. (L)	Looper asm. (R)	Looper asm. (C)				
		押さえ(組) (指ガード付)	送り歯(組)	ルーパー(L)(組)	ルーパー(R)(組)	ルーパー(C)(組)				
Needle gauge size 針幅	Code ゲージ 記号									
								inch	mm	Mark No.
E	7/32	5.6	12960167	12963450	12968558	1	12968855	1	12969150	1
F	1/4	6.4	12960068	12963351	↑	1	↑	1	↑	1
G	9/32	7.2	12960266	12963559	↑	1	↑	1	↑	1
H	5/16	8.0	12960365	12963658	12968657	2	12968954	2	↑	1
K	3/8	9.5	12960464	12963757	↑	2	↑	2	↑	1

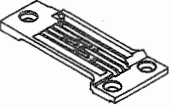
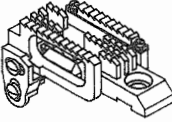

MS-1261/V045 (For Heavy-weight) — Option

MS-1261/V045 (厚物用) — オプション

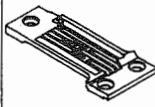
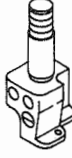
		1	2	3	
Description 品名		Gauge set	Throat plate	Feed dog asm.	
		ゲージセット	針板	送り歯(組)	
Needle gauge size 針幅	Code ゲージ 記号				
					inch
E	7/32	5.6	12972253	12972204	12974259
F	1/4	6.4	12972154	12972105	12974150
G	9/32	7.2	12972352	12972303	12974358
H	5/16	8.0	12972451	12972402	12974457
K	3/8	9.5	12972550	12972501	12974556

MS-1260・1261/V045 (For Medium-weight) —Option  
 MS-1260・1261/V045 (中厚物用) —オプション

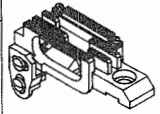
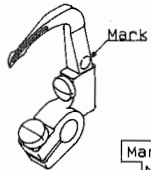
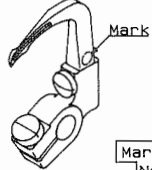
Model 機種	Description 品名		1		2		3		4		5		6		
			Gauge set		Gauge set (with finger guard)		Throat plate		Needle clamp asm.		Presser foot asm.		Presser foot asm. (with finger guard)		
	Needle gauge size 針幅		ケージセット		ケージセット (指力ート付)		針板		針留(組)		押さえ(組)		押さえ(組) (指力ート付)		
Code ケージ配号		inch	mm												
MS-1260/V045	D	3/16	4.8	12977955	12977963	12977906	12925954	12978250	12978268						
MS-1261/V045	E	7/32	5.6	12972956	————	12972907	————	————	————						
	F	1/4	6.4	12972857	————	12972808	————	————	————						
	G	9/32	7.2	12973053	————	12973004	————	————	————						
	H	5/16	8.0	12973152	————	12973103	————	————	————						
	K	3/8	9.5	12973251	————	12973202	————	————	————						

Model 機種	Description 品名		7		8		9		10		11		
			Feed dog asm.		Looper asm. (L)		Looper asm. (R)		Looper asm. (C)		Thread guide		
	Needle gauge size 針幅		送り歯(組)		ループ(L)(組)		ループ(R)(組)		ループ(C)(組)		針糸案内		
Code ケージ配号		inch	mm										
MS-1260/V045	D	3/16	4.8	12978755	12979258	3	12979357	2	————	B1130051000			
MS-1261/V045	E	7/32	5.6	12975058	————	————	————	————	————	↑			
	F	1/4	6.4	12974952	————	————	————	————	————	↑			
	G	9/32	7.2	12975157	————	————	————	————	————	↑			
	H	5/16	8.0	12975256	————	————	————	————	————	↑			
	K	3/8	9.5	12975355	————	————	————	————	————	↑			

12. Spacer for presser 押さえ用スヘーサ				Screw for spacer スヘーサ取付けねじ		
No	Thickness 板厚(mm)	Part No. 品番	Description 品名	Part No. 品番	Qty 個数	
①	0.3	12973509	Adjusting plate B 押さえ調節板 B	SS5060310SP	2	
②	0.5	12973608	Adjusting plate C 押さえ調節板 C	SS5060310SP	2	
③	0.8	12973707	Adjusting plate D 押さえ調節板 D	————	—	
④	1.2	12973806	Adjusting plate E 押さえ調節板 E	————	—	

13. Spacer for feed dog 送り歯用スヘーサ			
No	Thickness 板厚(mm)	Part No. 品番	Description 品名
①	0.3	12975702	Adjusting plate B 送り歯調節板 B
②	0.8	12975801	Adjusting plate C 送り歯調節板 C
③	1.0	12975900	Adjusting plate D 送り歯調節板 D

The spacer is not included in gauge set.  
 スヘーサは、ケージセットには含まれません。

The spacer and installing screws are not included in gauge set.  
 スヘーサおよびスヘーサ取付けねじは、ケージセットには含まれません。

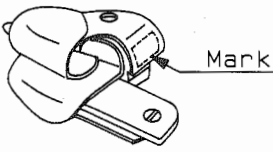
			14	15	16
Description 品名			Folder asm. フォルタ' (組)		
Needle gauge size 針 幅			M297	M298	M299
Mark			MH	H	XH
Code ケ-ジ' 配号					
	inch	mm			
D	3/16	4.8	MAM2970CCBA	—————	—————
E	7/32	5.6	MAM2970DDBA	MAM2980AABA	MAM2990AABA
F	1/4	6.4	MAM2970EEBA	MAM2980BBBA	MAM2990BBBA
G	9/32	7.2	MAM2970FFBA	MAM2980CCBA	MAM2990CCBA
H	5/16	8.0	MAM2970GGBA	MAM2980DDBA	MAM2990DDBA
K	3/8	9.5	MAM2970HHBA	MAM2980EEBA	MAM2990EEBA

The folder is not included in gauge set.  
フォルタ' は、ケ-ジ' セットには含まれません。

Folder mark  
フォルタ' 記号

M297 ——— Medium-weight

M298 ——— Heavy-weight

M299 ——— Extra heavy-weight (MS-1261/V045  
Standard equipment)

中厚物用

厚物用

極厚物用 (MS-1261/V045 標準装備)

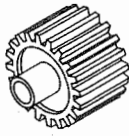
			17	18
Description 品名			Roller asm. 先引きローラ (組)	
Needle gauge size 針 幅			Steel roller スチールローラ	Urethane roller ウレタンローラ
Code ケ-ジ' 配号				
	inch	mm		
D	3/16	4.8	MAV045450A0	MAV045500B0
E	7/32	5.6	↑	↑
F	1/4	6.4	↑	↑
G	9/32	7.2	↑	↑
H	5/16	8.0	↑	↑
K	3/8	9.5	↑	↑

The cloth roller is not included in gauge set.  
先引きローラは、ケ-ジ' セットには含まれません。

The kind of roller

先引きローラ種類

Steel roller ——— Heavy & extra heavy-weight (MS-1261/V045 Standard equipment)  
スチールローラ 厚物・極厚物用 (MS-1261/V045 標準装備)

Urethane roller ——— Medium-weight  
ウレタンローラ 中厚物用

NUMERICAL INDEX OF PARTS

索引

PART NO 品番	PAGE 頁	REF NO	PART NO 品番	PAGE 頁	REF NO	PART NO 品番	PAGE 頁	REF NO	PART NO 品番	PAGE 頁	REF NO
A1161-001-00B	8	24	B2056-781-000	22	16	MAV-04501000	17	1	NS-6110430-SP	22	25
B1104-191-0A0	2	66	B2101-261-000-A	10	47	MAV-04502000	17	2	NS-6120310-SP	8	27
B1104-191-00A	2	67	B2102-026-0A0	10	20	MAV-04503000	17	7	NS-6150310-SP	10	13
B1104-191-00B	2	68	B2103-261-0A0	10	49	MAV-04504000	17	9	NS-6620310-SP	22	21
B1104-191-00C	2	69	B2105-019-00A	10	46	MAV-04505000	17	15			
B1106-191-000	2	72	B2105-019-000	10	45	MAV-04506000	17	16	PS-0250081-KO	10	55
B1127-026-000	8	7	B2106-026-000	10	69	MAV-04507000	17	18	PS-0300102-KO	17	12
B1128-804-000	2	24	B2107-019-000	10	23	MAV-04515000	18	1	PS-0300242-KO	17	11
B1130-026-000	2	26	B2108-026-000	10	43	MAV-04516000	18	7	PS-0500202-KP	4	32
B1130-051-000	2	38	B2115-191-000	10	16	MAV-045170A0	18	9			
B1131-026-000	2	28	B2116-019-00A	10	17	MAV-04517000	18	10	RC-0650811-KP	20	16
B1134-850-000-A	2	35	B2116-019-00B	10	18	MAV-045180A0	18	14	RC-1200001-KP	8	72
B1135-850-000	2	36	B2122-019-000	10	25	MAV-04518000	18	15	RC-1200001-KP	18	5
B1140-019-000	2	79	B2123-026-0A0	10	11	MAV-04519000	18	19	RC-1851217-KP	19	9
B1156-019-000	2	61	B2208-019-000	4	30	MAV-04520000	18	23	RE-0400000-KO	2	55
B1157-019-000	2	31	B2301-261-00A	4	12	MAV-045210A0	18	25	RO-0481901-00	8	6
B1161-026-000	2	10	B2310-019-000	4	2	MAV-04521000	18	26	RO-0611801-00	10	41
B1161-227-000	6	34	B2315-019-000	14	5	MAV-04522000	18	30	RO-0952001-00	10	70
B1162-026-0A0	2	8	B2317-019-000	14	7	MAV-045250A0	19	1	RO-0982401-00	6	35
B1202-512-000	6	9	B2319-191-00A	14	4	MAV-04525000	19	2			
B1203-512-000	6	23	B2321-019-000	14	9	MAV-04526000	19	6	SB-1060002-00	18	27
B1203-512-000	8	68	B2322-019-000	14	1	MAV-04527000	19	12	SB-1070001-00	20	12
B1207-026-0A0	6	1	B2324-261-000	8	26	MAV-04528000	19	14	SB-1080006-00	18	16
B1207-026-000	6	6	B2326-019-000	8	25	MAV-04529000	19	15	SB-1120005-00	18	4
B1208-019-000	6	5	B2328-019-000	8	28	MAV-04530000	19	16	SB-1350003-00	18	11
B1209-019-0A0	6	2	B2402-019-000	4	16	MAV-04530000	19	16	SB-1350003-00	18	11
B1211-019-000	6	27	B2421-019-000	4	19	MAV-04531000	19	17	SB-2120001-00	18	2
B1212-019-000	8	74	B2502-019-000	10	8	MAV-04532000	19	19	SB-3070004-00	20	4
B1214-019-000	6	26	B2503-019-000	10	28	MAV-04533000	19	21	SB-3070004-00	20	8
B1214-019-000	8	73	B2505-019-0A0	10	14	MAV-04534000	19	5	SB-3070004-00	20	19
B1219-019-000	2	21	B3107-804-000	4	5	MAV-045350A0	20	1	SB-3070005-00	20	3
B1222-019-000	6	18	B3112-704-000	4	7	MAV-04535000	20	2	SB-3100003-00	19	7
B1236-125-BA0	6	3	B3126-012-000	4	4	MAV-045360A0	20	6	SB-3100007-00	19	8
B1401-026-000	6	54	B3301-026-LAA	16	1	MAV-04536000	20	7	SB-3200003-00	19	3
B1402-026-BOG	6	45	B3311-012-000	16	13	MAV-04537000	20	14	SB-3200004-00	19	4
B1404-026-BOG	6	53	B3317-704-000	16	21	MAV-045380A0	20	18	SD-0380551-SL	2	37
B1408-038-000	6	4	B3318-704-L00	16	3	MAV-045380B0	20	17	SD-0450211-SP	14	6
B1409-019-0B0	6	50	B3319-704-L00	16	27	MAV-04541000	20	20	SD-0550451-SP	22	8
B1411-019-000	6	13	B3320-704-L00	16	12	MAV-04542000	20	21	SD-0600271-SP	22	24
B1411-552-0A0	8	11	B3321-704-LOB	16	17	MAV-04543000	20	23	SD-0600361-SP	22	12
B1411-552-000	8	12	B3321-704-L00	16	20	MAV-04544000	20	24	SD-0600402-TP	22	20
B1412-038-000	6	12	B3419-122-000	14	27	MAV-04545000	20	26	SD-0600596-SH	19	10
B1418-019-000	6	51	B3419-552-0A0-A	14	23	MAV-04546000	20	5	SD-0600756-TP	18	28
B1502-019-000	8	9	B3421-012-000	14	21	MAV-045470A0	20	10	SD-0640321-TP	22	14
B1504-019-0A0	8	14	B3426-122-000	14	15	MAV-04547000	20	11	SD-0640325-SP	22	11
B1506-019-000	8	19	B3427-122-000	14	19	MAV-045500A0	20	27	SD-0640751-SP	22	15
B1506-352-000	22	29	B3430-552-0A0	14	24	MAV-04555000	22	1	SD-0790431-SP	14	2
B1534-816-000	4	64	B3431-552-000-A	14	25	MAV-04556000	22	2	SD-0801606-SH	18	21
B1534-816-000	8	41	B3501-019-0A0	6	36	MAV-04557000	22	3	SK-3382001-SE	16	18
B1534-816-000	8	53	B3501-019-000	6	42	MAV-04558000	22	5	SK-3482500-SC	14	22
B1601-026-000	10	38	B3502-019-000	6	38	MAV-04559000	22	10	SM-4051405-SE	16	8
B1602-019-000	10	66	B3503-019-000	6	39	MAV-04560000	22	13	SM-4061201-SE	16	16
B1606-191-000	10	65	B3504-019-000	6	37	MAV-04561000	22	18	SM-5030355-SE	17	8
B1610-019-000	10	39	B3508-019-000	6	40	MAV-04562000	22	23	SM-5040655-SN	17	10
B1621-261-000-A	10	63	B3510-019-000	6	10	MAV-04563000	22	35	SM-5040655-SN	17	17
B1623-191-000	10	58	B3513-261-000	2	81	MAV-04564000	22	26	SM-6031202-TP	17	13
B1624-191-000	10	54	B3526-226-000	2	82	MAV-04565000	22	28	SM-6031402-TP	22	37
B1625-191-000	10	57	B3541-012-000	6	11	MAV-04566000	22	30	SM-6040802-TP	20	13
B1626-191-000	10	56	B3701-019-000	14	3	MAV-04567000	22	31	SM-6040802-TP	20	22
B1630-191-000	2	57	B8101-191-0A0	14	10	MAV-04568000	22	33	SM-6040802-TP	22	6
B1631-191-000	2	60	B8101-191-000	14	13	MAV-04569000	22	34	SM-6041002-TP	22	9
B1632-191-000	2	59	B8102-191-0A0	14	11	MAV-04616000	22	19	SM-6051002-TP	18	8
B1633-191-000	2	54	B8228-125-000	2	84	MC-3800012-00	6	63	SM-6061002-TP	22	27
B1634-191-000	2	56	B8511-180-000	14	14	MC-3800013-00	6	58	SM-6061200-SE	16	4
B1635-191-000	10	34	B8514-180-000	14	17				SM-6061202-TP	8	33
B1802-019-000	8	60	CQ-2020000-00	10	19	NM-6030003-SC	17	14	SM-6061602-TP	18	20
B1803-019-000	8	61	CQ-2520000-00	6	44	NM-6030003-SC	22	38	SM-6061602-TP	18	24
B1805-019-000	2	48	CQ-3000000-00	6	47	NM-6040003-SC	19	11	SM-6062002-TP	17	3
B1806-019-000	2	49	CS-1201010-SH	18	3	NM-6050001-SE	16	9	SM-6062002-TP	20	29
B1808-019-0A0	8	62	D2587-L8W-B00	22	7	NM-6050001-SE	16	26	SM-6040302-TP	19	20
B1901-026-000	6	48	MAM-2970CCBA	8	30	NM-6060001-SE	16	19	SM-8040402-TP	20	9
B2001-261-0A0	10	35	MAM-2990BBBA	8	29	NM-6060003-SC	18	22	SM-8040402-TP	20	28
B2002-026-000-A	10	27	MAO-11532000	16	24	NM-6060003-SC	20	30	SM-8040602-TP	19	18
B2003-026-000	10	30				NM-6080001-SC	22	32	SM-8040602-TP	20	25
B2006-019-0A0	10	32				NM-6080003-SC	18	17	SM-8050502-TP	20	15
						NS-6110310-SP	4	11	SM-8050602-TP	19	13
						NS-6110350-SP	4	59	SM-8060602-TP	18	12

# NUMERICAL INDEX OF PARTS

索引

PART NO 品番	PAGE 頁	REF NO	PART NO 品番	PAGE 頁	REF NO	PART NO 品番	PAGE 頁	REF NO	PART NO 品番	PAGE 頁	REF NO
SM-8060602-TP	22	4	SS-7110710-SP	14	8	115-03604	4	67	129-60068	8	45
SM-8082502-TP	18	18	SS-7110830-SP	8	59	115-50308	4	1	129-60803	8	36
SM-9061850-SC	17	5	SS-7110830-SP	10	26	119-57008	4	8	129-62007	8	38
SS-1090510-SP	6	30	SS-7110840-SP	4	46	119-57404	16	10	129-62106	8	39
SS-2060510-SP	4	22	SS-7110840-SP	4	65	119-57503	16	6	129-62205	8	42
SS-2110920-TP	6	59	SS-7110840-SP	4	66	119-57602	16	2	129-62205	8	54
SS-3060710-SP	2	27	SS-7110910-TP	8	34	119-57602	16	15	129-62304	8	46
SS-3090610-SP	2	39	SS-7111110-TP	8	15	129-21003	2	3	129-62304	8	58
SS-4091010-SP	2	9	SS-7111110-TP	10	12	129-21409	2	20	129-62601	10	67
SS-4091010-SP	2	23	SS-7111110-TP	10	15	129-21508	2	19	129-62809	10	40
SS-4091010-SP	4	28	SS-7111110-TP	10	36	129-21607	2	25	129-63005	10	59
SS-4110815-SP	2	13	SS-7111110-TP	10	51	129-21904	4	62	129-63062	10	53
SS-4120915-SP	2	6	SS-7111120-SP	2	58	129-22001	4	63	129-63302	12	13
SS-4622340-SP	4	18	SS-7111410-SP	4	48	129-22605	2	52	129-63351	10	4
SS-5060410-SP	4	23	SS-7120910-SP	6	14	129-22803	4	51	129-63351	12	12
SS-5060410-SP	8	40	SS-7151210-SP	2	22	129-23207	2	12	129-64102	12	15
SS-5060410-SP	8	52	SS-7151210-SP	2	71	129-24502	6	19	129-64102	12	36
SS-5090420-SP	4	45	SS-7621040-SP	10	37	129-24700	6	24	129-64201	12	14
SS-5090710-SP	2	11	SS-7740740-SP	2	51	129-24700	8	69	129-64300	12	16
SS-5091020-SP	2	42	SS-7740740-SP	6	17	129-24759	6	22	129-64300	12	37
SS-5110810-SP	2	77	SS-8080310-TP	6	56	129-24759	8	67	129-64409	12	17
SS-5660440-SP	6	41	SS-8080310-TP	6	62	129-24809	6	20	129-64409	12	38
SS-5820540-SP	2	78	SS-8080610-SP	6	57	129-24809	8	76	129-64508	12	19
SS-6060210-SP	4	31	SS-8110310-SP	8	63	129-25004	6	29	129-64607	12	20
SS-6060410-TP	8	43	SS-8110310-SP	8	66	129-25954	6	61	129-64706	12	21
SS-6060410-TP	8	55	SS-8110410-TP	10	33	129-31507	10	61	129-64805	12	18
SS-6090540-SP	2	46	SS-8110410-TP	10	62	129-31606	10	60	129-65505	8	71
SS-6090620-SP	2	50	SS-8110422-TP	10	42	129-31705	10	64	129-65703	2	40
SS-6090670-TP	8	13	SS-8110510-SP	10	44	129-31903	10	52	129-66008	4	40
SS-6090670-TP	12	44	SS-8111160-SP	4	10	129-35516	4	34	129-66107	4	39
SS-6090910-TP	12	5	SS-8150310-SP	6	46	129-35807	4	41	129-66206	4	38
SS-6090910-TP	12	24	SS-8150310-SP	8	10	129-35805	4	47	129-66305	4	35
SS-6090910-TP	12	29	SS-8150310-SP	10	29	129-35904	4	68	129-66503	8	65
SS-6092120-SP	6	43	SS-8150410-SP	10	31	129-36217	4	44	129-66552	8	64
SS-6110480-SP	2	70	SS-8150710-SP	6	25	129-36506	4	49	129-66602	4	9
SS-6110610-TP	2	5	SS-8150710-SP	8	70	129-36803	4	29	129-66701	4	13
SS-6110610-TP	4	52	SS-8150710-SP	10	24	129-36902	4	33	129-66800	2	15
SS-6110610-TP	8	4	SS-8151150-SP	10	9	129-38205	4	3	129-66909	2	43
SS-6111610-SP	6	21	SS-8152030-SP	6	32	129-38304	4	6	129-67006	2	44
SS-6111610-SP	8	77	SS-8660522-TP	6	28	129-39500	4	54	129-67105	2	45
SS-6122030-SP	2	18	SS-8660610-TP	6	7	129-39609	4	55	129-67204	4	24
SS-6122030-SP	10	71	SS-8660612-TP	10	50	129-39708	4	56	129-67303	4	21
SS-6150810-SP	8	44	SS-8660612-TP	10	68	129-39906	4	58	129-67402	4	26
SS-6150810-SP	8	56	SS-9151210-TP	14	12	129-40102	2	64	129-67501	2	17
SS-6151220-SP	6	8	SS-9151440-CP	8	75	129-41100	12	11	129-67800	4	15
SS-7060510-SP	4	17	SS-9182010-SN	14	16	129-41100	12	32	129-67709	4	57
SS-7080510-TP	10	22	SS-9182010-SN	14	20	129-42009	12	3	129-67758	4	53
SS-7080510-TP	10	48	SS-9284043-CP	2	74	129-42009	12	27	129-68004	10	10
SS-7080510-TP	12	4	SS-9661120-CP	14	18	129-43106	6	15	129-68103	8	1
SS-7080510-TP	12	28	SS-9661120-CP	14	26	129-43205	2	83	129-68202	8	3
SS-7090510-SP	4	14				129-43700	2	73	129-68509	12	2
SS-7090510-SP	4	20	TA-1250406-RO	2	7	129-50507	2	32	129-68558	10	1
SS-7090510-SP	12	22				129-50705	2	1	129-68558	12	1
SS-7090510-SP	12	42	WP-0371016-SD	4	36	129-50804	2	4	129-68806	12	7
SS-7090520-SP	4	27	WP-0371016-SD	4	69	129-51000	2	16	129-68855	10	2
SS-7090530-SP	4	37	WP-0450000-SD	8	5	129-51505	4	61	129-68855	12	6
SS-7090530-SP	4	42	WP-0450801-SD	2	41	129-51950	2	75	129-69101	12	10
SS-7090530-SP	4	70	WP-0480856-SP	22	22	129-52008	2	76	129-69150	10	3
SS-7090530-SP	6	16	WP-0641600-SC	17	4	129-52255	2	30	129-69150	12	9
SS-7090710-SP	2	14	WP-0641600-SC	17	6	129-52552	2	29	129-69309	12	8
SS-7090710-SP	2	47	WP-0641600-SC	18	29	129-53204	6	60	129-70406	2	80
SS-7090710-SP	4	25	WP-0651056-SH	22	17	129-55209	6	31	129-73608	8	51
SS-7090710-SP	8	8	WP-0841601-SC	18	13	129-55308	6	33	129-75504	12	35
SS-7090850-SP	4	43	WP-1221016-SP	18	6	129-55803	2	33	129-77906	6	64
SS-7090910-SP	2	34	WP-1702600-SO	16	23	129-56256	6	55	129-78201	8	49
SS-7090910-SP	6	52	WS-0510002-KN	16	25	129-58500	8	18	129-78250	8	47
SS-7090910-TP	6	49	WS-1643202-KR	16	22	129-58559	8	17	129-78268	8	57
SS-7090920-SP	10	21	WZ-1200200-KP	18	31	129-58609	8	16	129-78409	8	48
SS-7091110-TP	12	23				129-58807	8	20	129-78508	8	50
SS-7091110-TP	12	43	107-04203	2	53	129-59003	8	22	129-78706	12	34
SS-7091410-SP	8	2	110-00403	2	2	129-59052	8	21	129-78755	10	7
SS-7110710-SP	2	63	110-18603	2	62	129-59102	8	23	129-78755	12	33
SS-7110710-SP	2	65	111-83902	16	14	129-59300	8	31	129-78805	12	40
SS-7110710-SP	2	85	111-84009	16	11	129-59409	8	32	129-78904	12	41
SS-7110710-SP	4	50	111-84108	16	5	129-60001	8	37	129-79001	12	39
SS-7110710-SP	4	60	111-84207	16	7	129-60050	8	35	129-79209	12	26

NUMERICAL INDEX OF PARTS

索引

PART NO 品番	PAGE 頁	REF NO	PART NO 品番	PAGE 頁	REF NO	PART NO 品番	PAGE 頁	REF NO	PART NO 品番	PAGE 頁	REF NO
129-79258	10	5									
129-79258	12	25									
129-79308	12	31									
129-79357	10	6									
129-79357	12	30									
135-15606	22	36									

# JUKI

## JUKI CORPORATION

HEAD OFFICE  
8-2-1, KOKURYO-CHO,  
CHOFU-CITY, TOKYO 182, JAPAN

BUSINESS OFFICE  
1-23-3, KABUKI-CHO,  
SHINJUKU-KU, TOKYO 160, JAPAN

PHONE : 03(3205)1188, 1189, 1190  
FAX : 03(3203)8260, (3205)9131  
TELEX : J22967, 232-2301

## JUKI 株式会社

〒182 東京都調布市国領町8-2-1  
TEL. 03-3480-1111(代表)

工業製品販売本部  
TEL. 03-3480-1113(ダイヤルイン)

お買い求め、ご相談は  
To order or for further  
information,  
please contact :

- \* このパーツリストは商品改良のため予告なく変更する事があります。
- \* The description covered in this parts list is subject to change for improvement of the commodity without notice
- \* このパーツリストは、1993年11月現在の商品仕様で編集・印刷したものです。
- \* This parts list is edited and printed in accordance with the product specifications as of November 1993.