

CONSEW[®] *Since 1898*

— CONSOLIDATED SEWING MACHINE CORP.

PARTS MANUAL FOR

MODELS 493 / 494 / 495 / 495H

HIGH SPEED OVERLOCK MACHINES

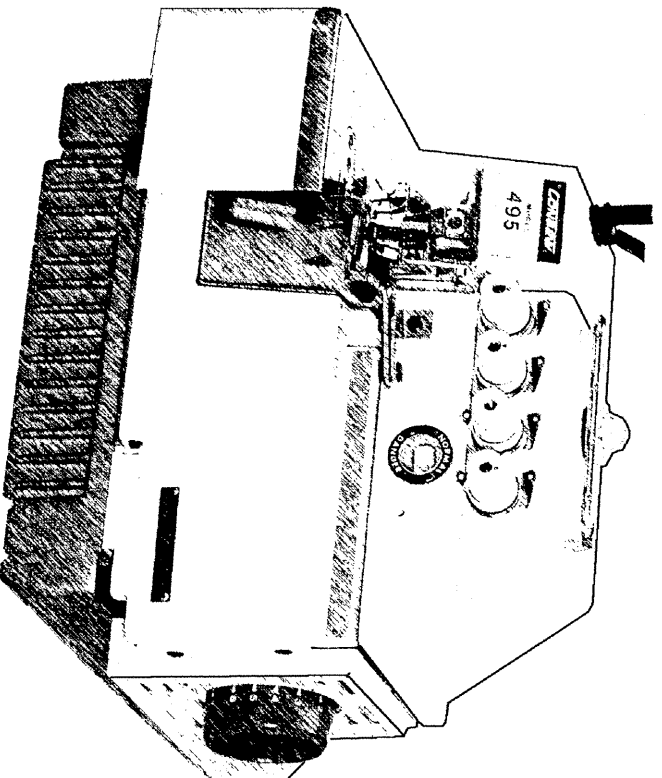

MODEL	NEEDLES	THREADS
493	1	3
494	2	4
495 / 495H	2	5

Intentionally left blank

对于缝纫机本身及各种装置，我们充分考虑到它的安全性，请遵照基本的操作方法，安全地进行工作。

● 拆除为保证安全所设置的装置、零件的情况下使用，是非常危险的，请绝对不要拆除后使用。

● 缝纫机在使用时，请不要在缝纫机台板上放置工具及缝纫时不必要的物品。

● 在对缝纫机进行检修、调节、清扫、穿线、换针等工作时，为防止发生事故，务必请切断电源，在确认即使踩下缝纫机踏板，缝纫机也不转动之后，再进行操作。

注意

使用离合式马达的情况下，在关掉电源①后，因惯性作用马达仍会继续旋转。这时如不注意踩动缝纫机踏板②时，缝纫机会突然动作，这是很危险的。

请在关掉电源后，仍继续踩动踏板②，直至缝纫机完全停下来为止。

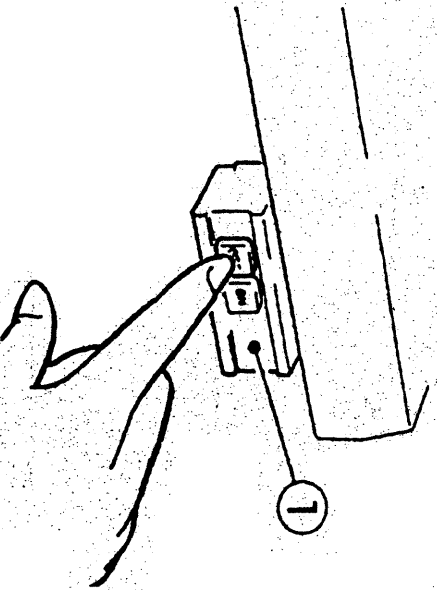

● 在离开缝纫机台时，务必请关掉电源。

● 停电时也请务必关掉电源。

● 为了总是安全地、运转良好地使用缝纫机，日常的点检是不可缺少的，请予以注意。

OBSERVE THESE SAFETY PRECAUTIONS

Though Consew takes the utmost care to produce safe sewing machines and devices, operators should follow these basic safety rules.

● To prevent accidents, do not remove safety devices or parts while operating the machine.

● Do not leave tools or other unnecessary objects on the machine table while operating the machine.

● Before maintenance, adjusting, cleaning, threading or replacing the needle, and to prevent accidents, be sure the power is turned off. Check that the machine will not operate when the pedal is pressed.

Note

In case a clutch type motor is used, it will keep on rotating by inertia after turning off power supply ①. If the machine pedal ② is stepped on inadvertently, it is dangerous because the machine will move unexpectedly. Keep on stepping on the machine pedal ② until the machine comes to a stop after turning off the power supply ①.

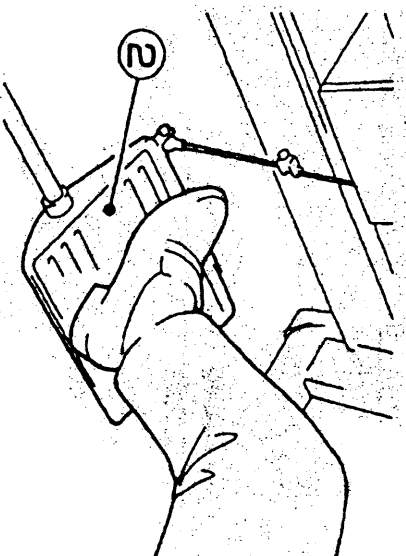

● Turn the power off before leaving the machine table.

● In the event of a power failure, be sure to turn the machine off.

● Check that the machine is securely grounded.

目录 CONTENTS

■在使用之前 BEFORE OPERATING	
○台板加工图	4
Schematic diagram of the machine table	
○缝纫机的安装方法	5
Installing the machine head	
○缝纫机的旋转方向及转数	6
The machine speed and the turning direction	
○供油	7
Lubrication	
○手动给油	8
Manual lubrication	
○给 HR 装置供油	9
Filling the HR device with silicon oil	
○穿线的方法	10
Threading	
■试缝 TEST SEWING	
○压脚压力的调节	11
Adjusting the presser foot pressure	
○差动比的调节	12
Adjusting the diff. feed ratio	
○针脚长度的调节	13
Adjusting the stitch length	
○线状态的调节	14
Adjusting the thread tension	
■使用中的保养	
MAINTENANCE DURING USE	
○缝纫机的清扫	15
Cleaning the machine	
○换针	16
Replacing the needle	
○检查机油的循环	17
Checking the oil circulation	
○换机油	18
Replacing the oil	
○下刀片的更换	19
Replacing the lower knife	
○调整标准参数表	20
Adjustment dimensions	
○机针标准	20
Standard needle	

缝纫机的安装方法 Installing the machine head

1. 将缝纫机装于台板之上，给缝纫机侧皮带轮和马达侧皮带轮装上三角胶带。
2. 将马达高度调整到用手按压皮带中间时，约有 2cm 左右的松弛量为好。
3. 请装好皮带的护盖。

1. Mount the machine head on the machine rest board.
2. Adjust the tension of the belt so that it can be about 2cm bent inward when you press the middle of it.
3. Install the belt cover referring to the Figure.

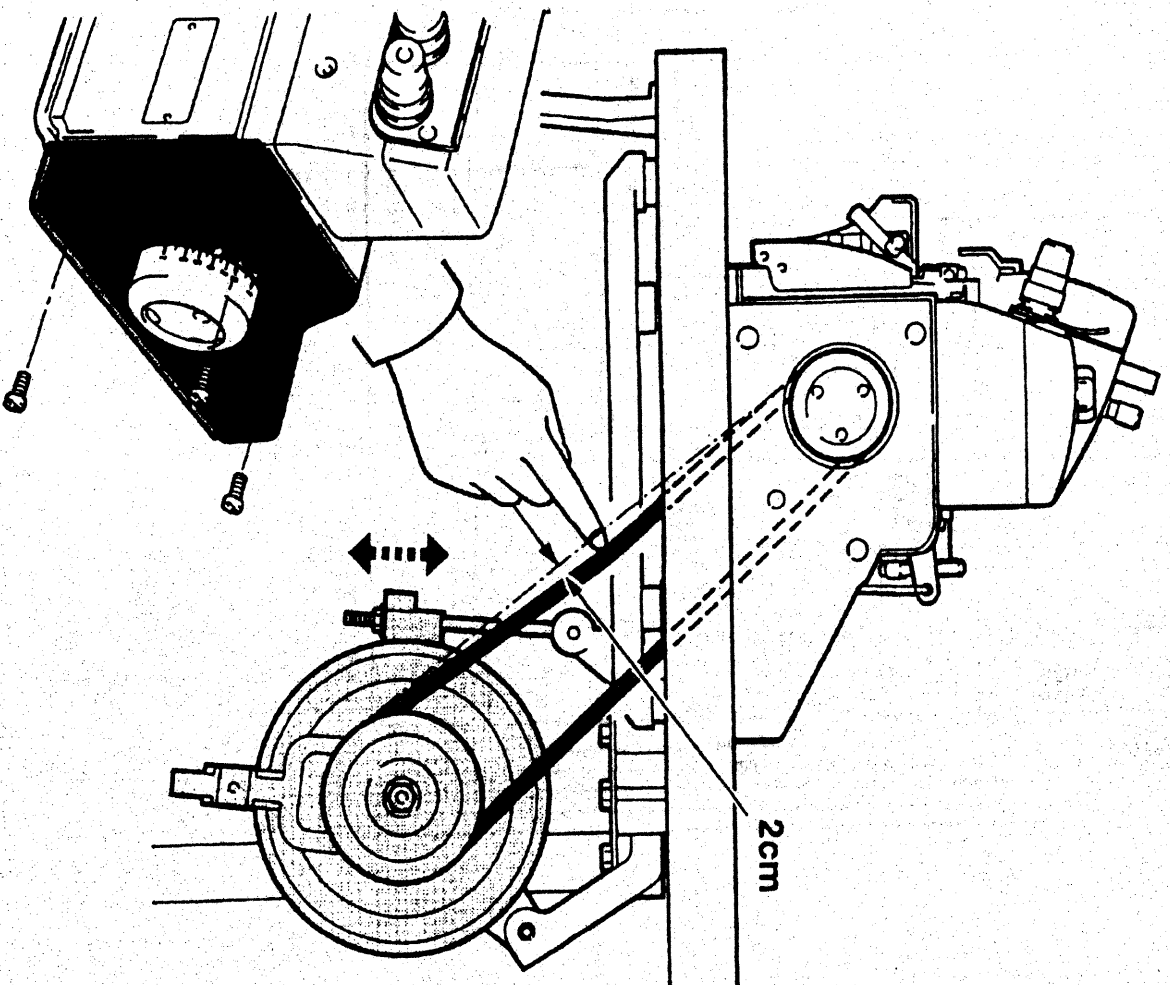

BEFORE OPERATING

缝纫机的旋转方向及转速
The machine speed and turning direction

缝纫机的旋转方向，从皮带轮侧看
是向右旋转的。

The machine rotates clockwise when seen from the
machine pulley side.

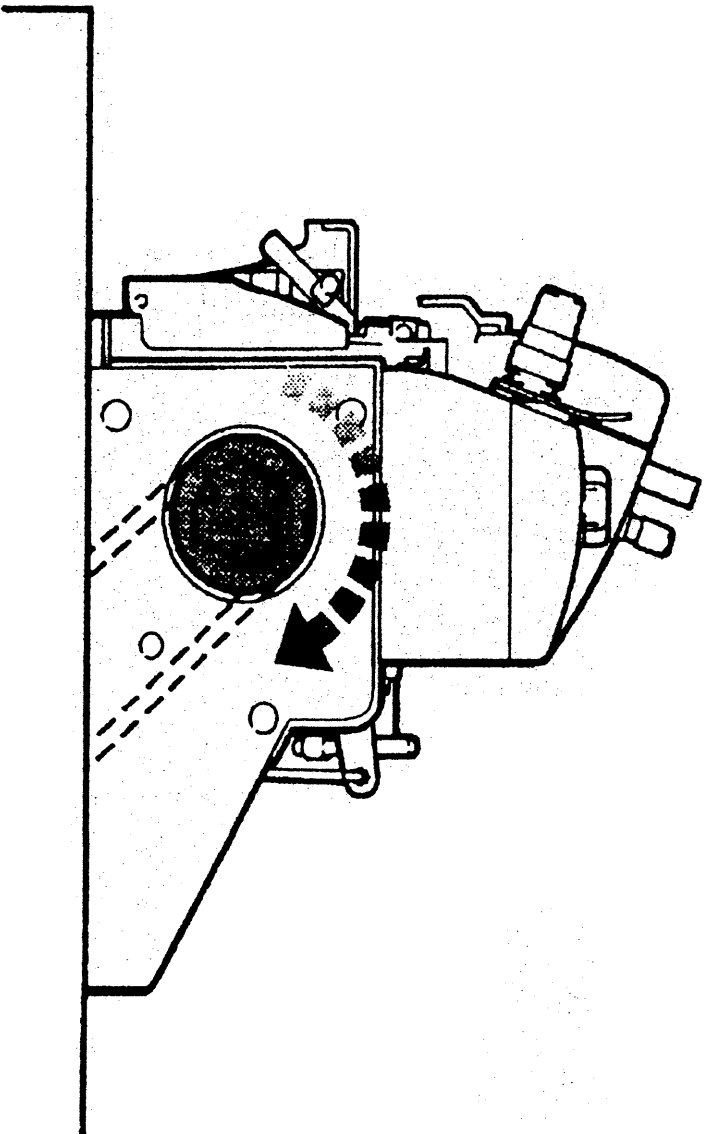

参照下表选用与所使用的缝纫机对应的转速
Make sure your machine type and run it not
exceeding the maximum speed as listed in

缝纫机机型 Model	最高旋转数 (r. p. m) Sewing speed (max)
4 9 3	7, 000
4 9 4	6, 500
4 9 5	6, 500
4 9 5 H	5, 500

供油 Lubrication

加油量是使油量指示器顶端处于H
线与L线之间为好，当其低于L线时，
就要及时补充机油。

机油请使用本公司指定的 (HIGH
SPEED SEWING MACHINE OIL)

After filling the oil pan, the top of oil indicator
should lie between (H) and (L) lines.

Add oil, when it reaches or goes below (L).

Note: Use our company recommended oil [HIGH
SPEED SEWING MACHINE OIL]

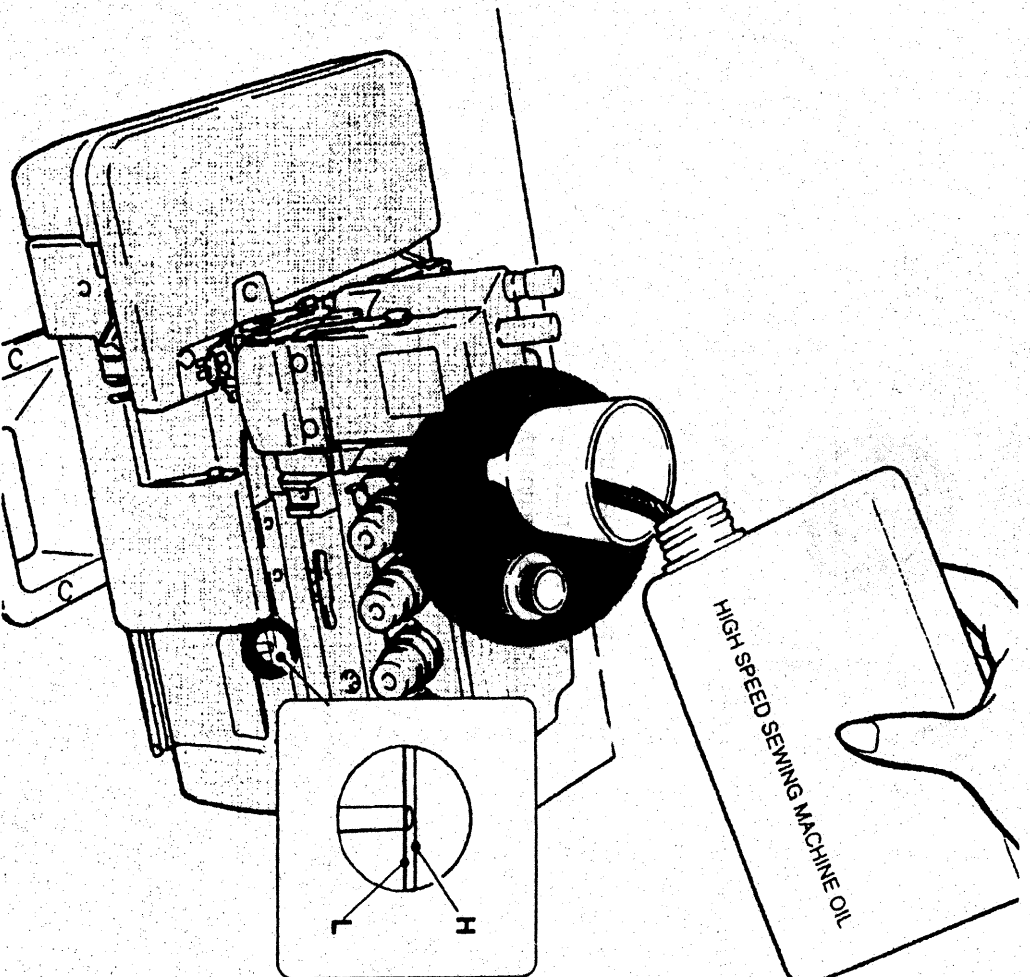

在使用之前
BEFORE OPERATING

手动给油 Manual Lubrication

手动给油是在缝纫机最初开始使用时，
或停用一段时间重新开始时使用，请供给
2—3滴油。

机油请使用本公司指定的 (HIGH SPEED
SEWING MACHINE OIL)

Apply 2 or 3 drops of oil by hand when the ma-
chine is used for the first time or has been left
unused for some time.

Note: Use our company recommended oil
[HIGH SPEED SEWING MACHINE OIL]

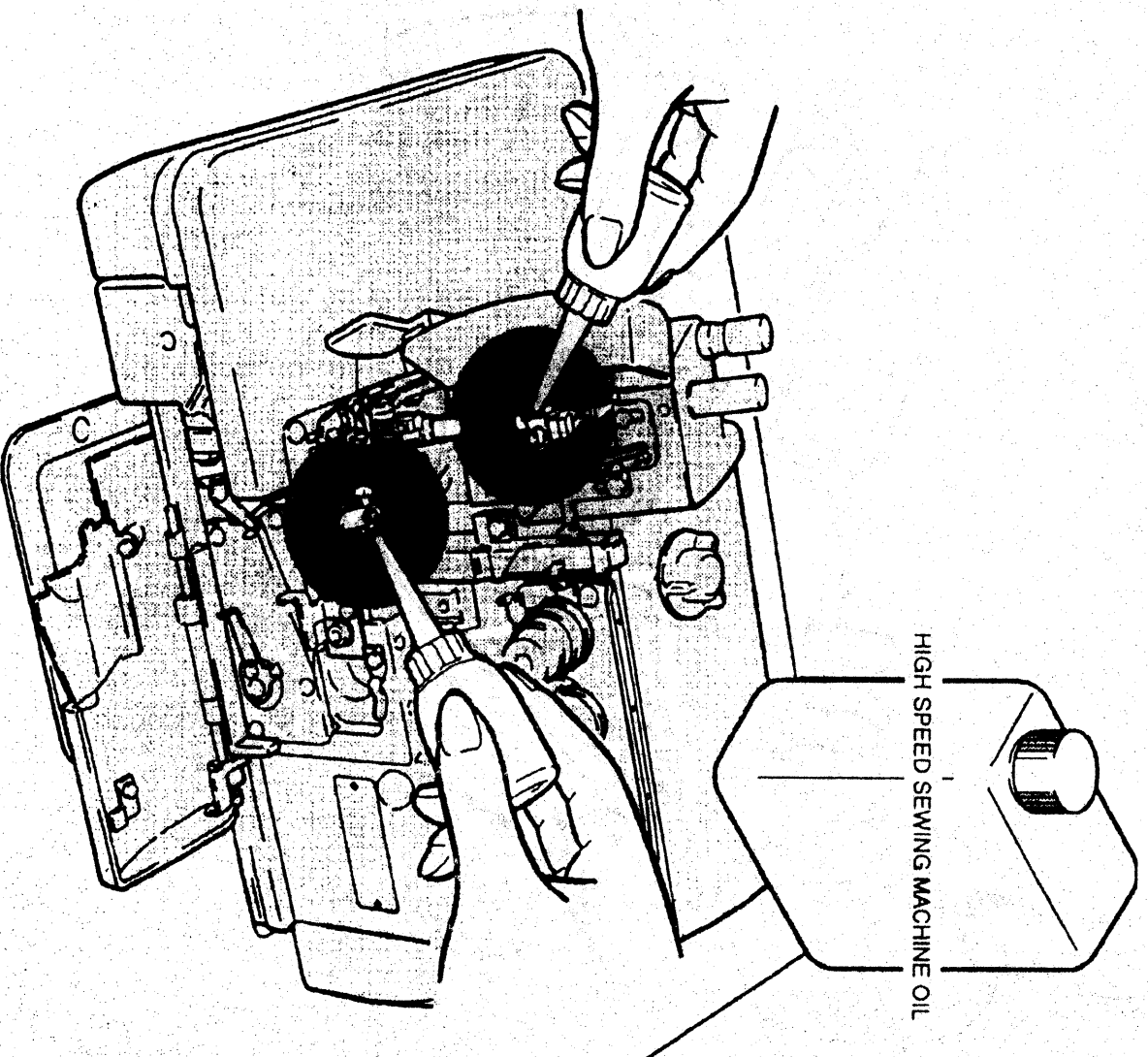

HR 装置供油

给 HR 装置供油
Filling the HR device with silicon oil

为了防止布纤维或线被切断，请尽早给
HR 装置供油。

Fill the HR device with oil before it is too low in
order to prevent needle thread breakage and
fabric damage.

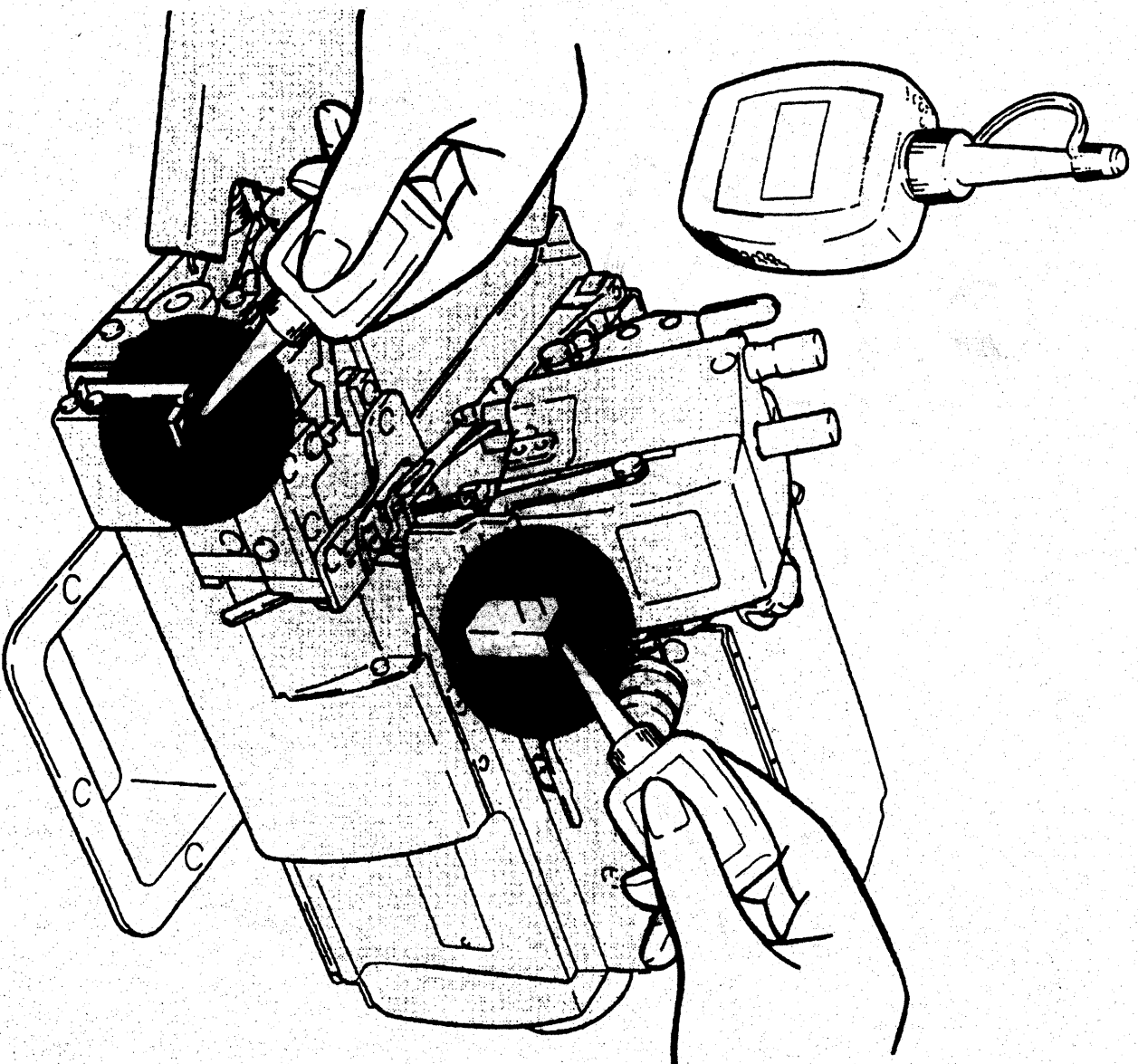

在使用之前
BEFORE OPERATING

穿线的方法 Threading

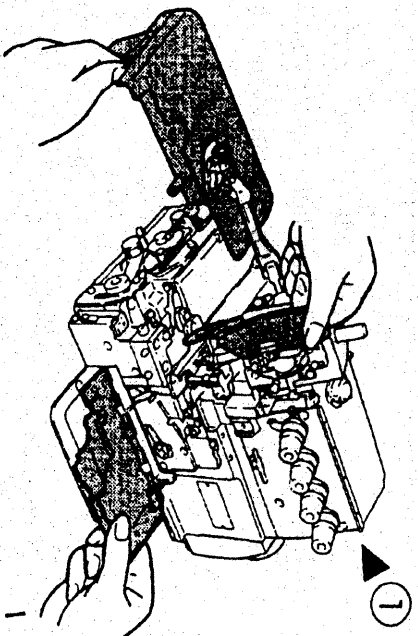

① 打开压脚臂及机盖 (三处)
Open three covers.
Swing the presser foot aside.

把机上原有的线与缝纫用线绑结在一起。
Knot the preset thread and the thread
being used together to thread the machine.

针线

将线拉到针眼前，剪掉
结头再次穿好针线。

Needle thread
Trim the knots off
neatly before passing
through the eye of
the needle to
rethread.

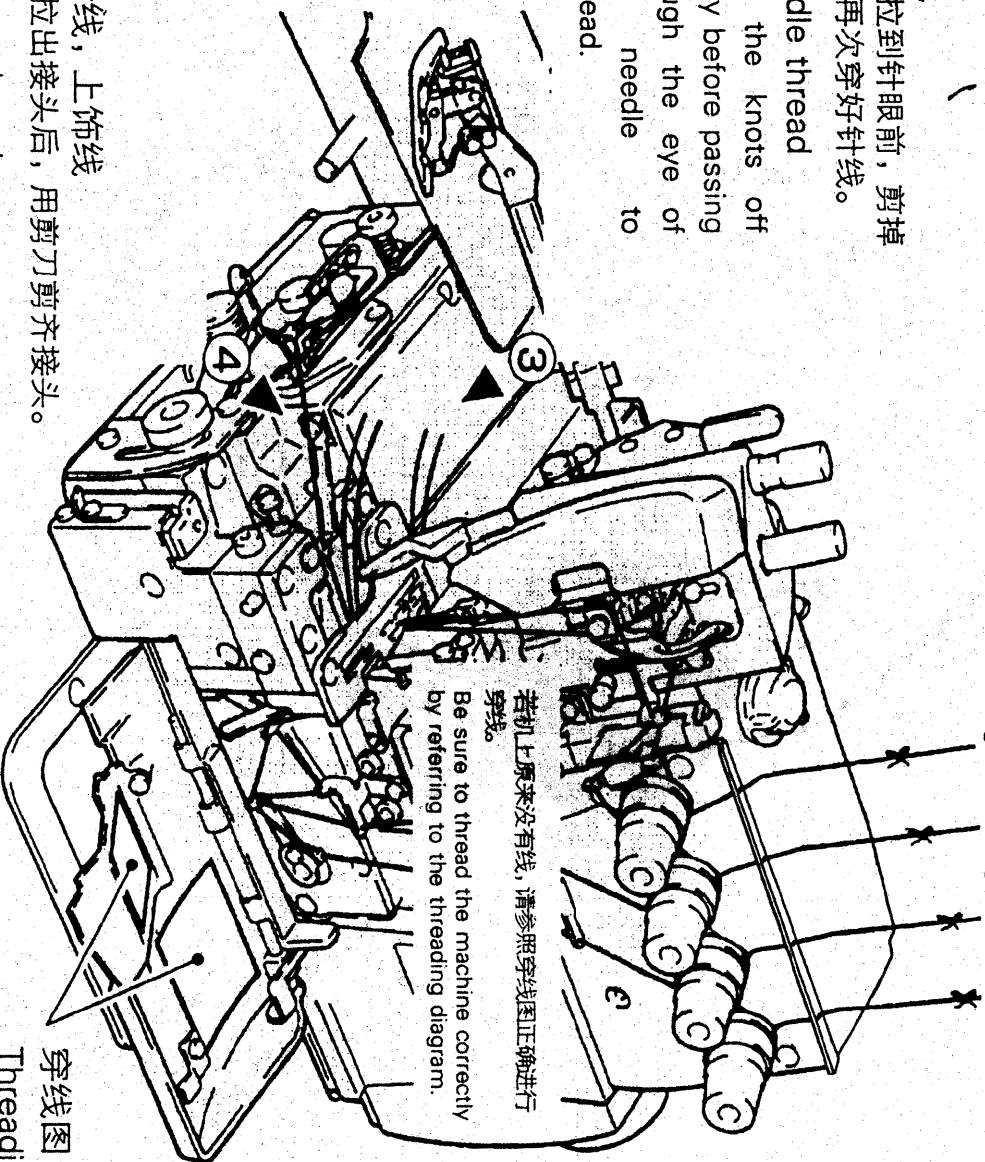

若机上原来没有线，请参照穿线图正确进行
穿线。
Be sure to thread the machine correctly
by referring to the threading diagram.

穿线图

Threading diagram

弯针线，上饰线
直到拉出接头后，用剪刀剪齐接头。

Looper thread
Trim the knots off neatly after passing
through the eye of the looper.



压脚压力的调节 Adjusting the presser foot pressure

压脚压力的调节可旋转螺帽进行调节。在送布状态良好并能取得均匀针脚的范围内，尽可能使用较弱的压力为好。

Turn adjusting screw to adjust the presser foot pressure. It should be as light as possible, yet be sufficient to obtain the proper stitch formation.

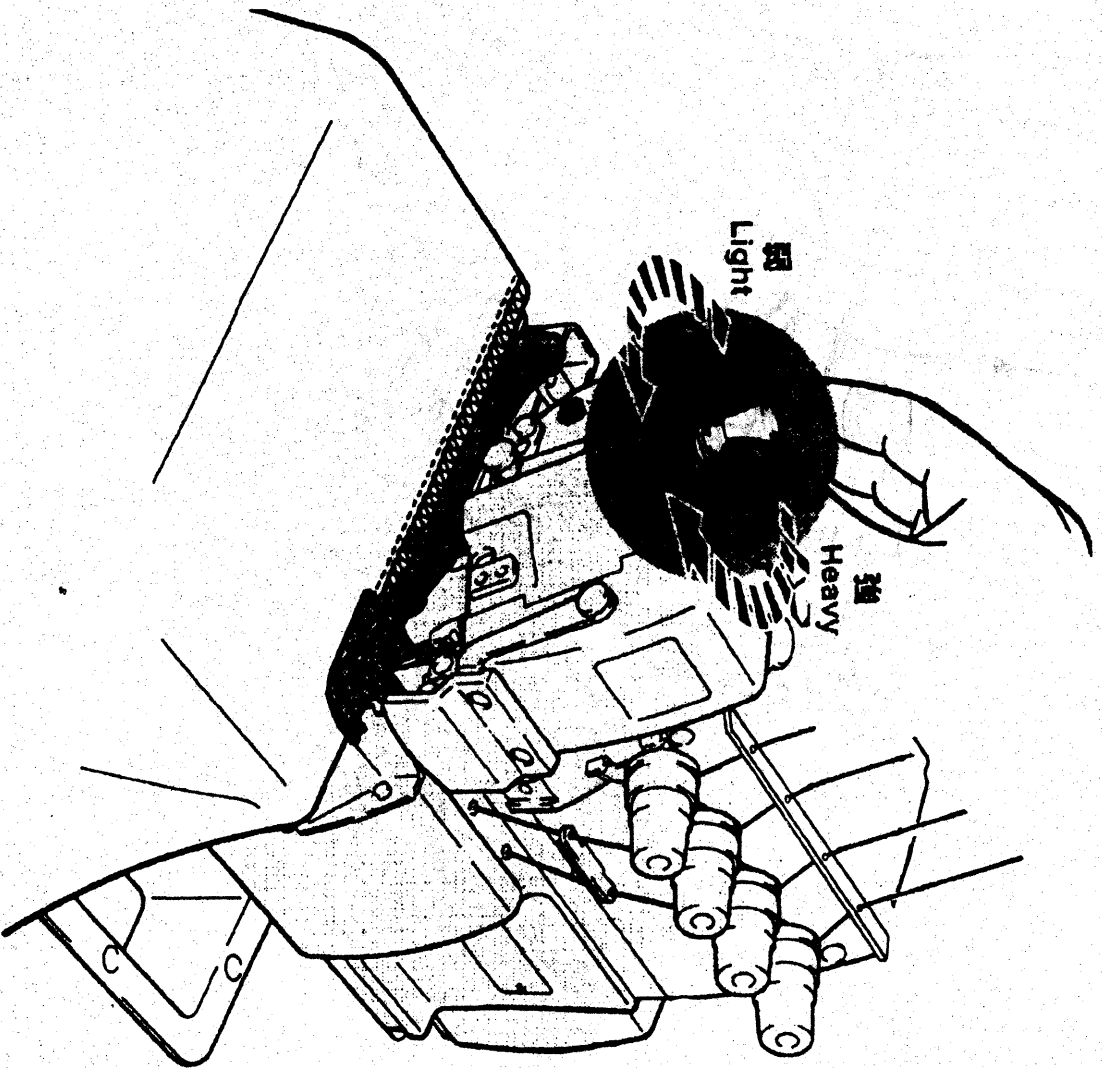

差动比的调节 Adjusting the diff. feed ratio

差动比的调节是松开螺母后，上下移动来进行调节。调节完后，将螺母拧紧。

Loosen the nut and move the lever up and down to obtain the correct differential feed ratio. Tighten the nut after positioning the lever as desired.

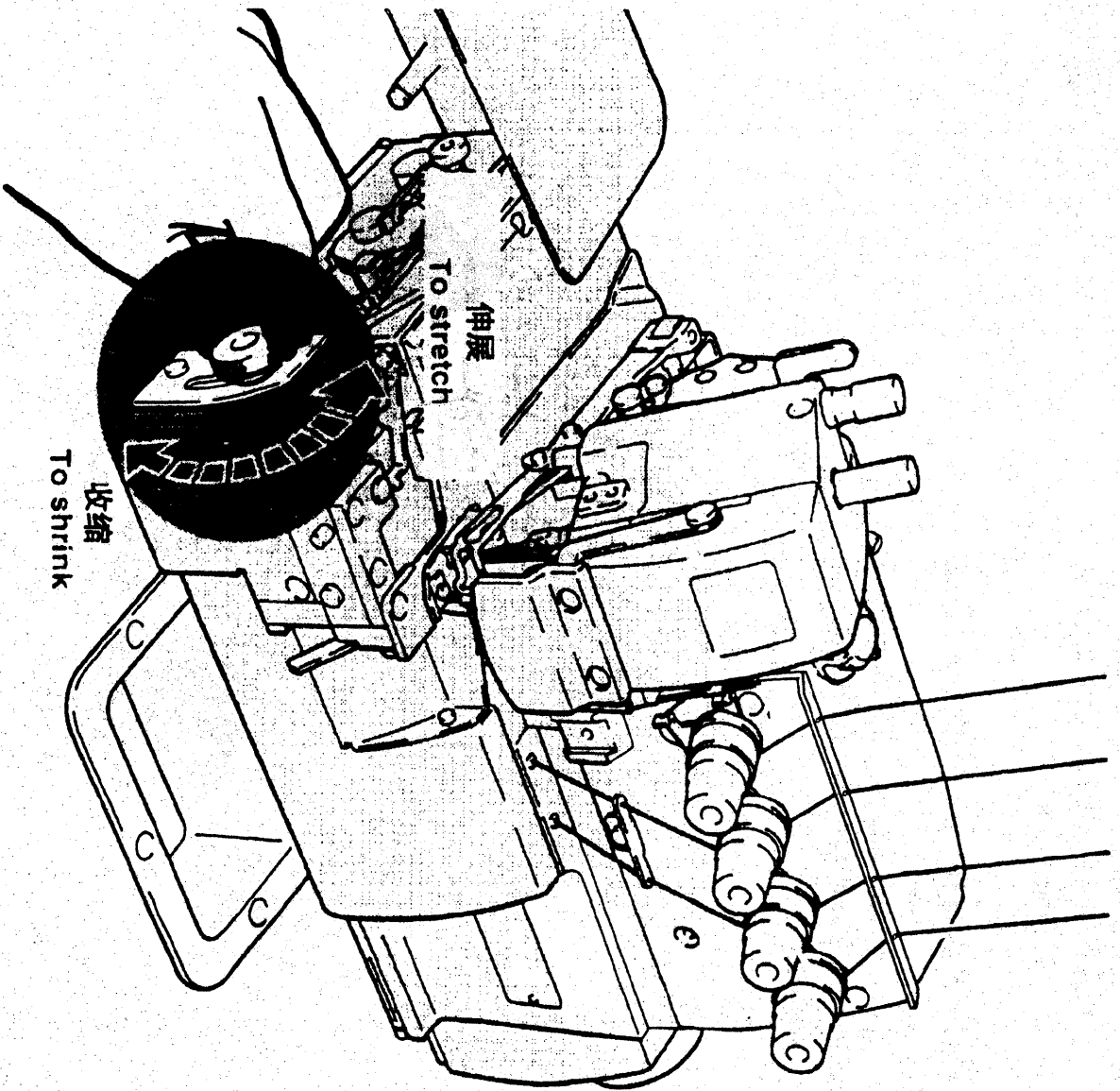

线状态的调节 Adjusting the thread tension

线张力状态的调节，请用针线调节螺帽①，上弯针线调节螺帽②，弯针线调节螺帽③来进行调节。

Make tension adjustments with the needle thread knot ①, the upper looper knob ②, and the lower looper knob ③.

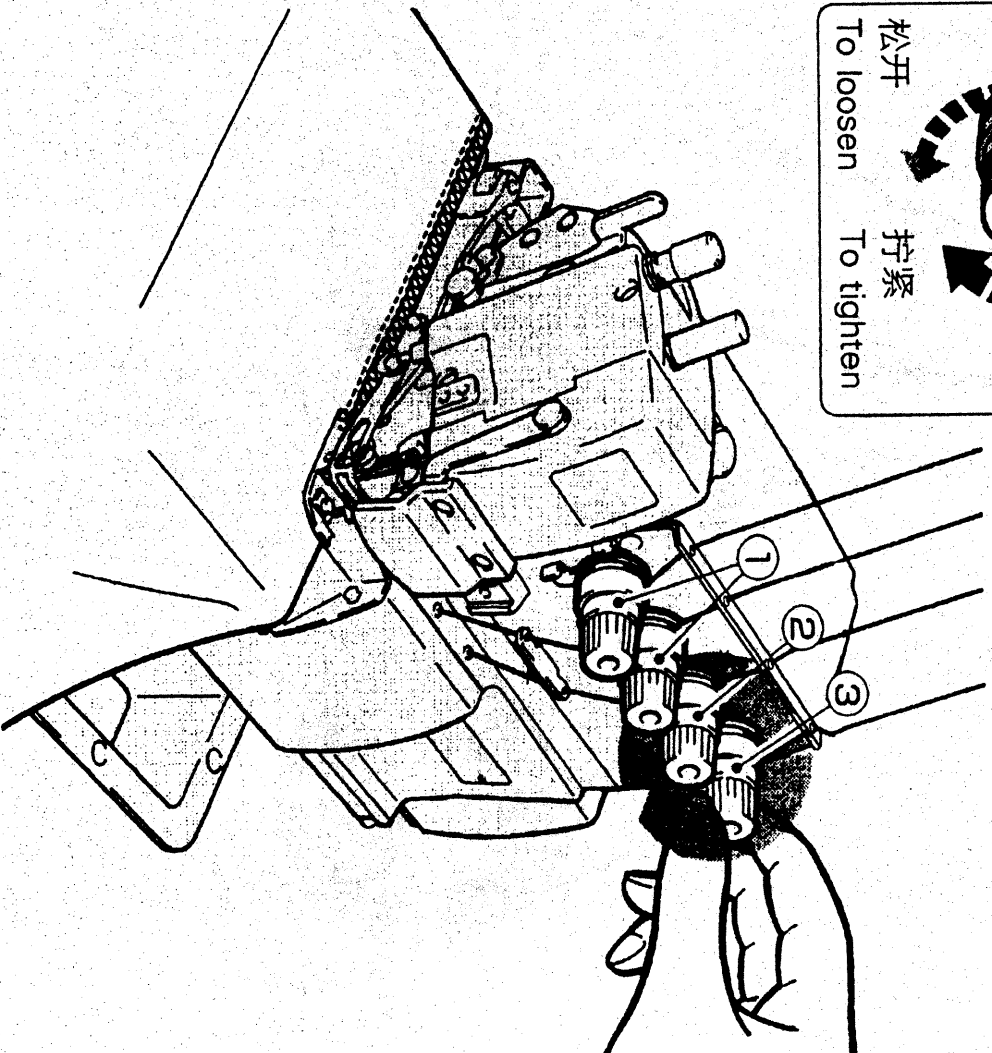
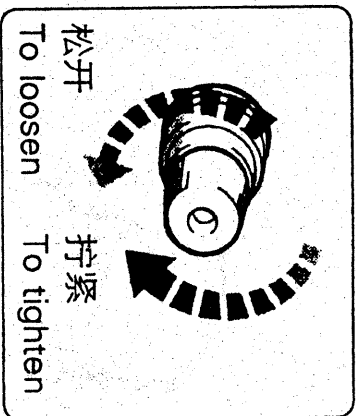



缝纫机的清扫 Cleaning the machine

缝纫机的清扫，以针板槽及送布牙周围
为主。

Mainly the slots of the needle plate and the feed
rows should be cleaned.

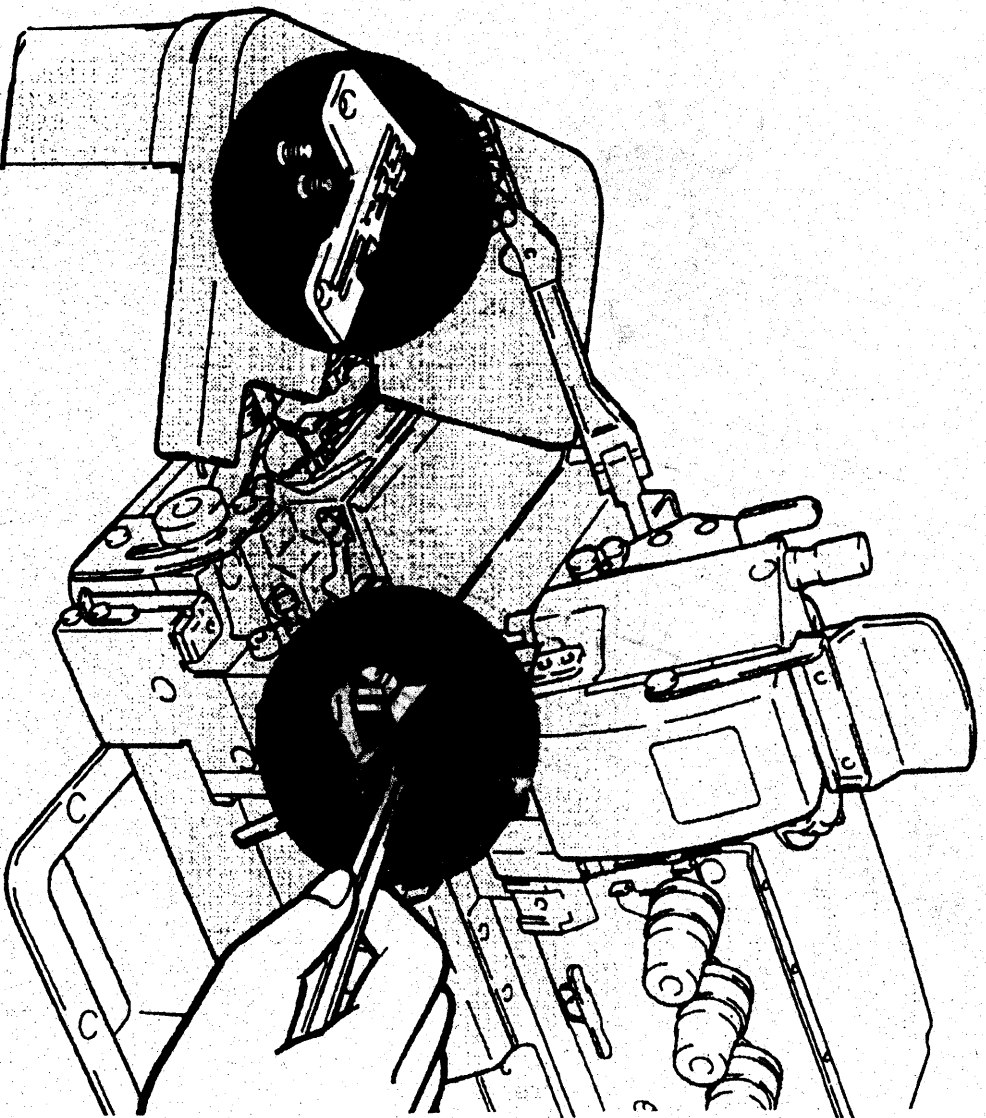

换针 Replacing the needle

准确辨认针的前后，请将针凹向着后方，即背向操作者进行安装。
针要牢固地插到孔的最深处。

Check the needle carefully to see that the scarf is turned to the rear of the machine. Insert the needle to the proper depth, and fasten securely.

标准使用的缝纫针，请参照卷末附有的“调整标准表”

Be sure to use standard needle. Refer to ADJUSTMENT DIMENSIONS on the end of instructions.

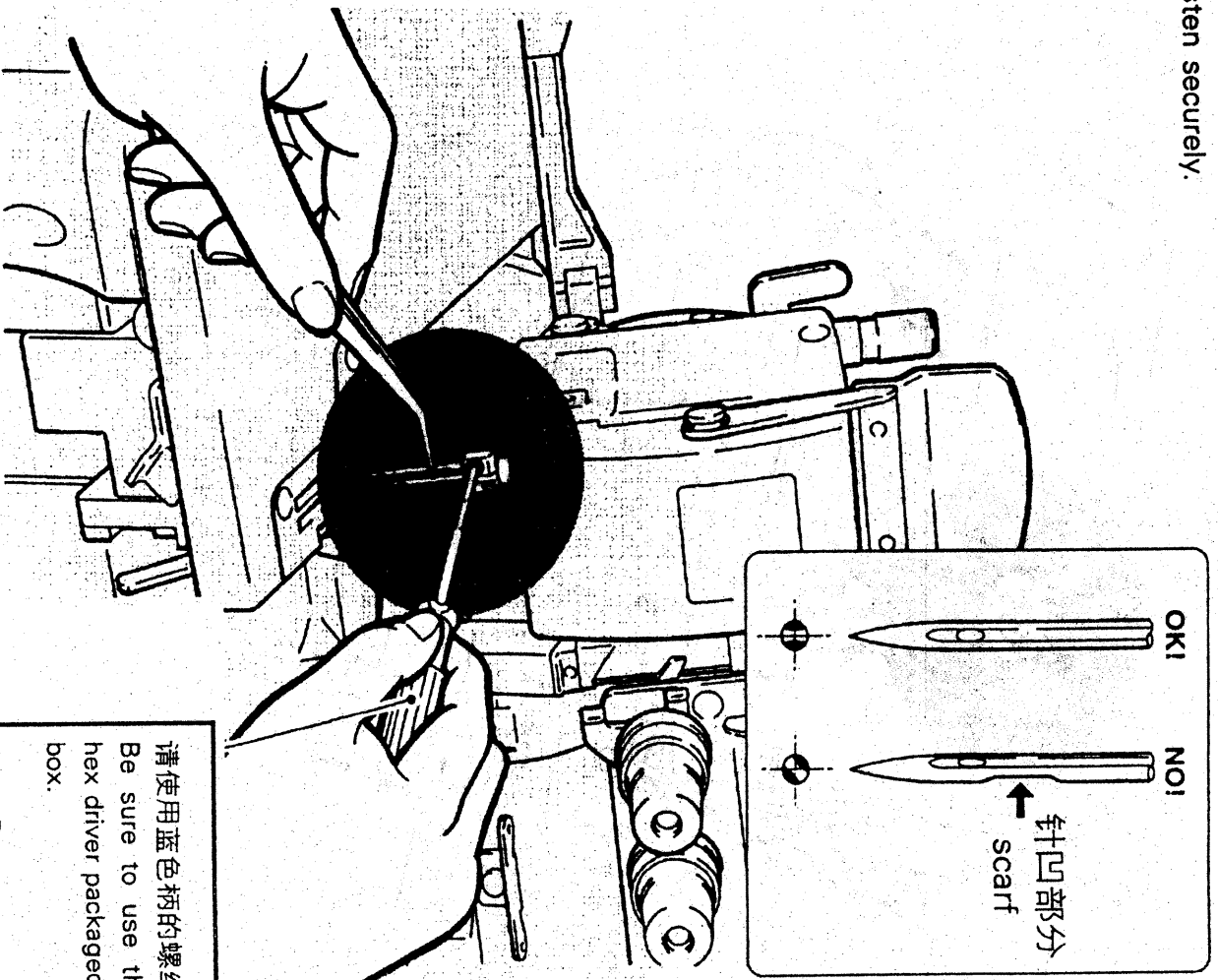

请使用蓝色柄的螺丝扳手(附件中)。
Be sure to use the blue - handed
hex driver packaged in the accessory
box.

Note Do not remove the screw.

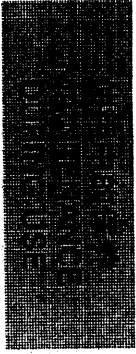

检查机油的循环

Checking the oil circulation

OK! 运转中
Operating

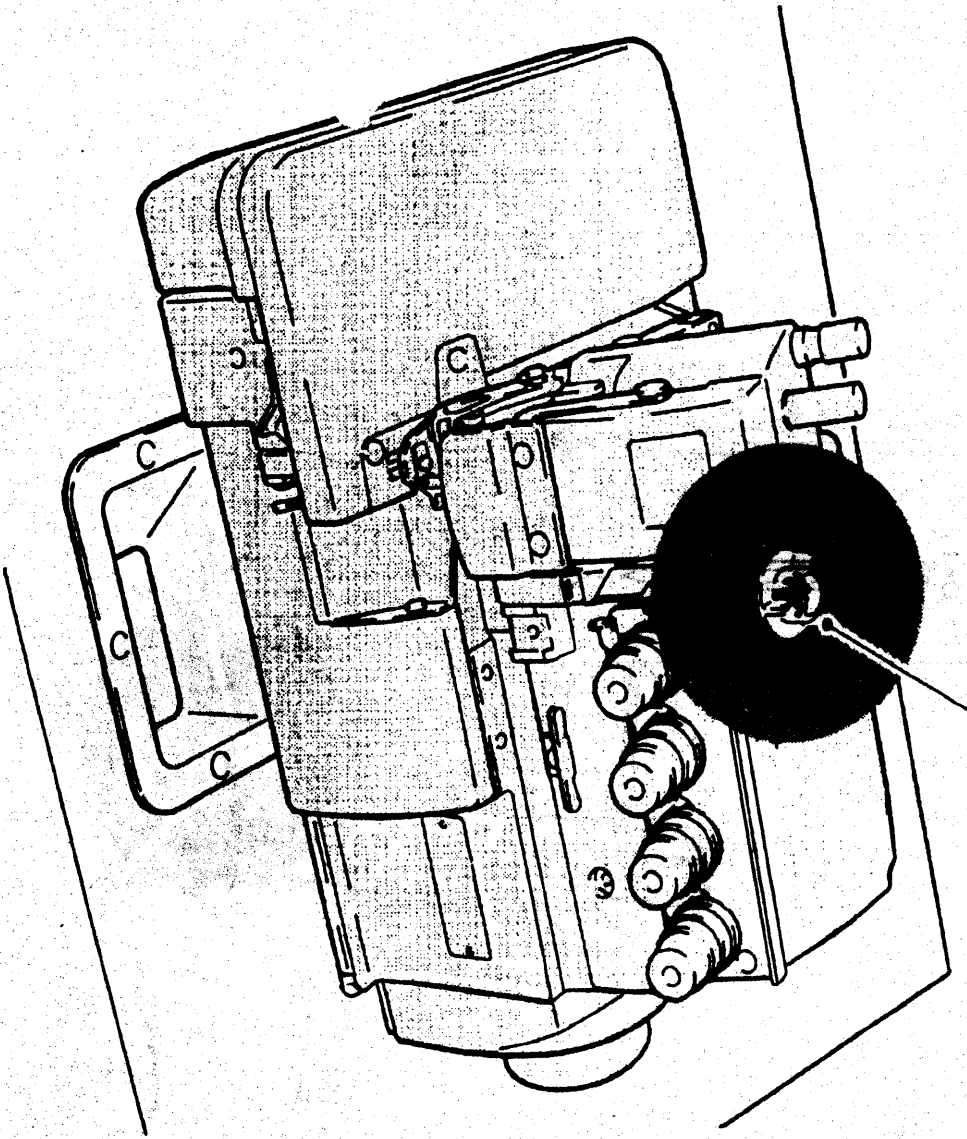

换机油 Replacing the oil

机油的更换，请在使用开始 1 个月
后更换一次，然后，每 6 个月更换一次。

Replace the oil one month after the first use and every six months thereafter. (See p7.)

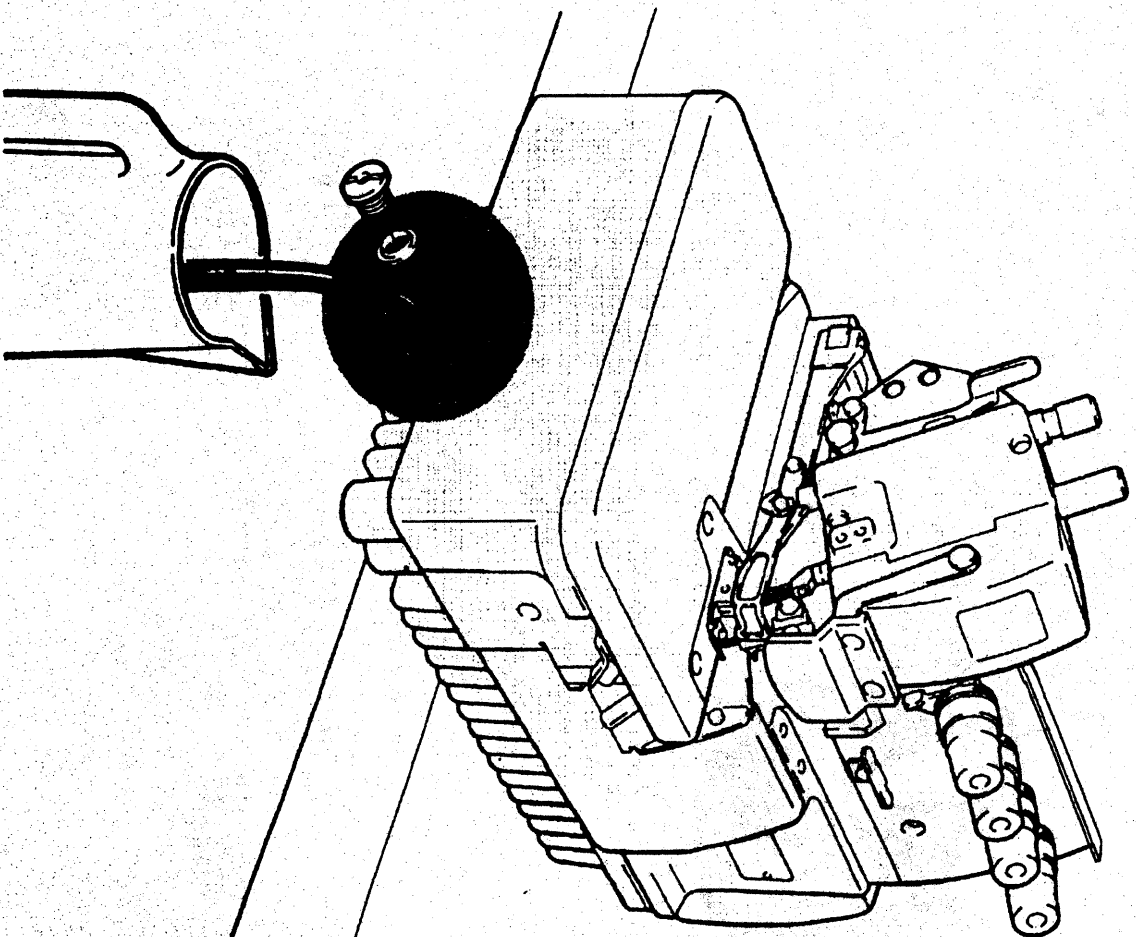



下刀片的更换 Replacing the lower knife

下刀片正确的研磨角度
Correct angles to resharpen the lower knife.

卸下下刀片
To remove the lower knife

把下刀架推向左边，用螺丝①暂时固定。
Temporarily screw ① after sliding the lower knife holder to the left.

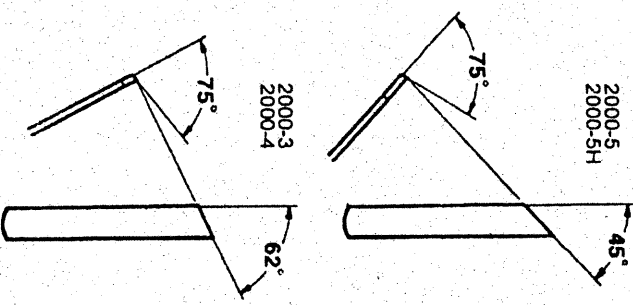
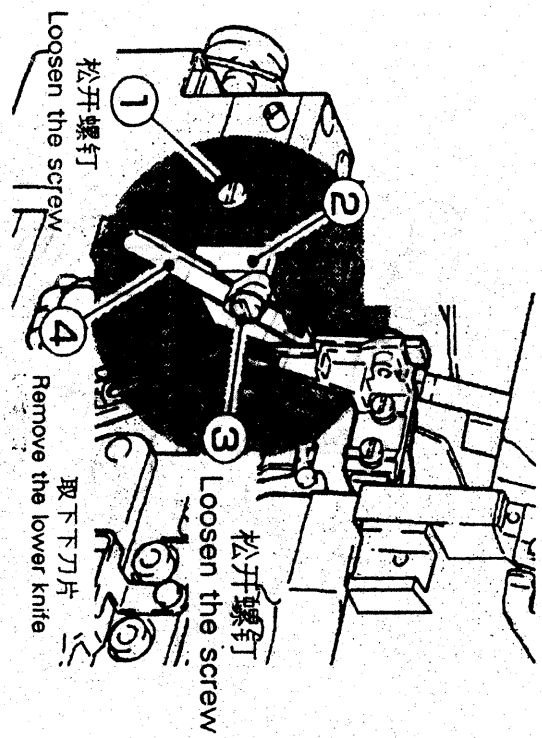

安装下刀片
To replace the lower knife

转动手轮将上刀移动对准如右图所示位置。
Turn the handwheel as the drawing on the right figure.

松开螺丝⑤，下刀架则向右移动。
Loosening the screw ⑤ makes the lower knife holder slide to the right.

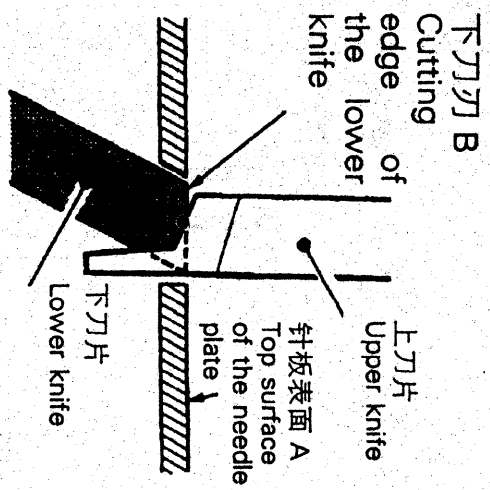
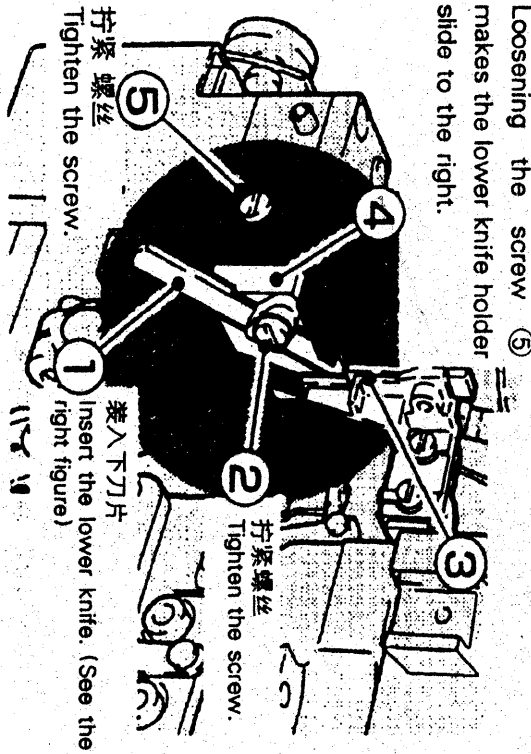

使针板表面 A 与下刀刃 B 处于相同水平位置。
Level of A = Level of B

装好下刀片后进行剪线，确认剪切状况。
Check cutting action of knives.

495 495H

调整标准表 Adjustment dimentionns

495	10.6	3.9	3.3	0.9-1.1	5.5	1.5				
495H	12.0	3.4	3.3	0.9-1.1	5.5	1.5				

(mm)

493 494

调整标准表 Adjustment dimentionns

493	10.1	4.2	3.3	0.9-1.1	5.5					
494	10.1	4.6	4.0	0.9-1.1	5.5					

(mm)

49x series 系列标准使用的缝纫针 Standard needle

		Organ DC x27
493		11
494		11
495		14
495 H		21

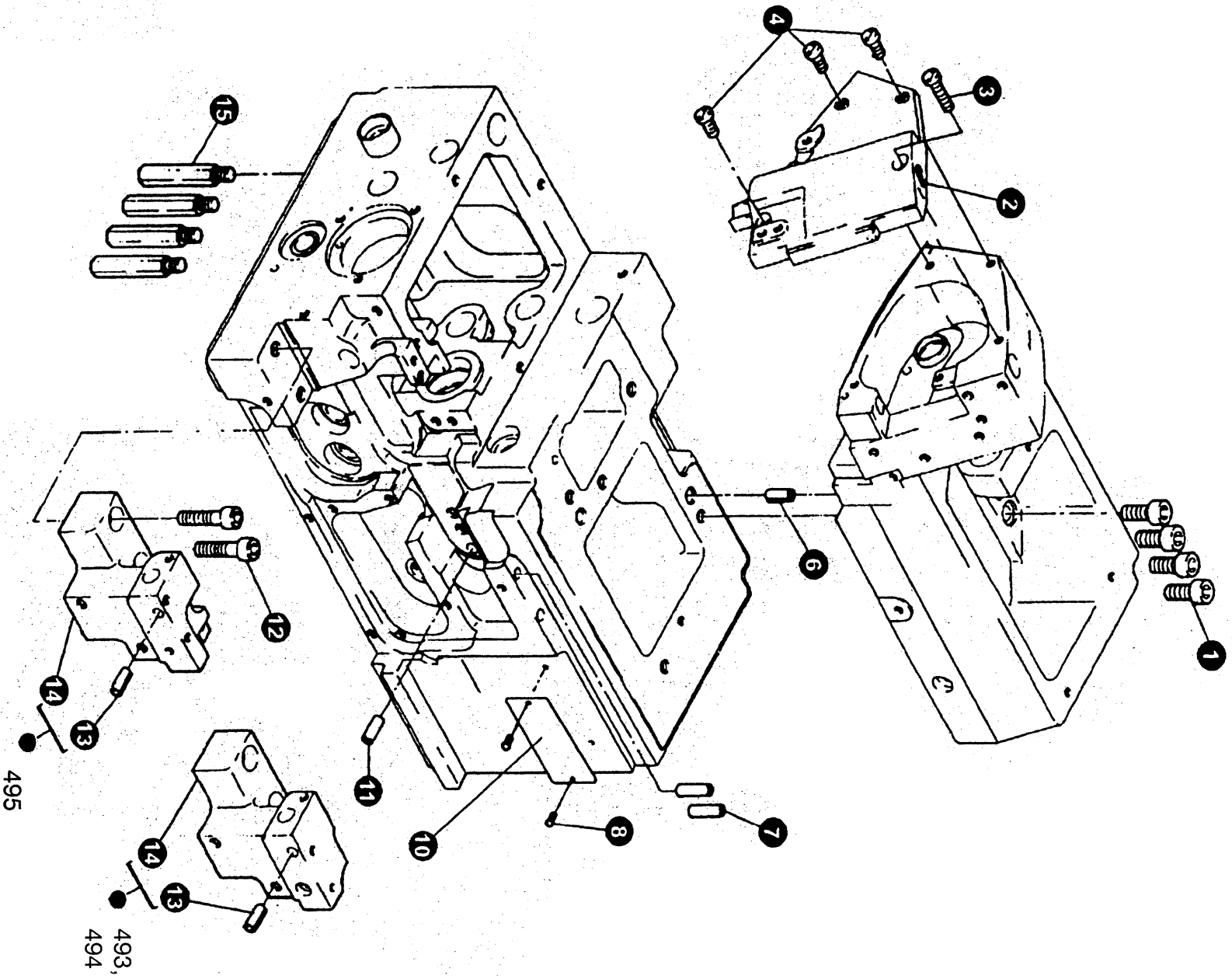

一. 机壳部件(1)/MACHINE ARM PARTS(1)

序号 No	图号/Ret. No.	名称/Description	件数/Qt				
			3	4	5	5H	
1	S150220005	机壳螺钉(M6×16)	4	4	4	4	
2	155100001	压脚壳	1	1	1	1	
3	S150215011	压脚壳螺钉(长)(M4×18)	1	1	1	1	
4	S150215009	压脚壳螺钉(短)(M4×10)	3	3	3	3	
6	S8A3104007	圆柱弹性销(5×16)	2	2	2	2	
7	155100002	过线管	2	2	2	2	
8	022120003	铆钉(2.5×5)	2	2	2	2	
10	180100001	型号牌	1				
	159100002	型号牌		1		1	
	155100007	型号牌			1	1	
11	S8A3104007	导架座圆柱弹性销(5×16)	1	1	1	1	
12	S150220016	内六角头螺钉(M6×25)	2	2	2	2	
13	S8A3104007	圆柱弹性销(5×16)	1	1	1	1	
14	159100001	下切刀架座	1	1			
	155100003	下切刀架座			1	1	
15	155100005	机壳支承螺钉	4	4	4	4	

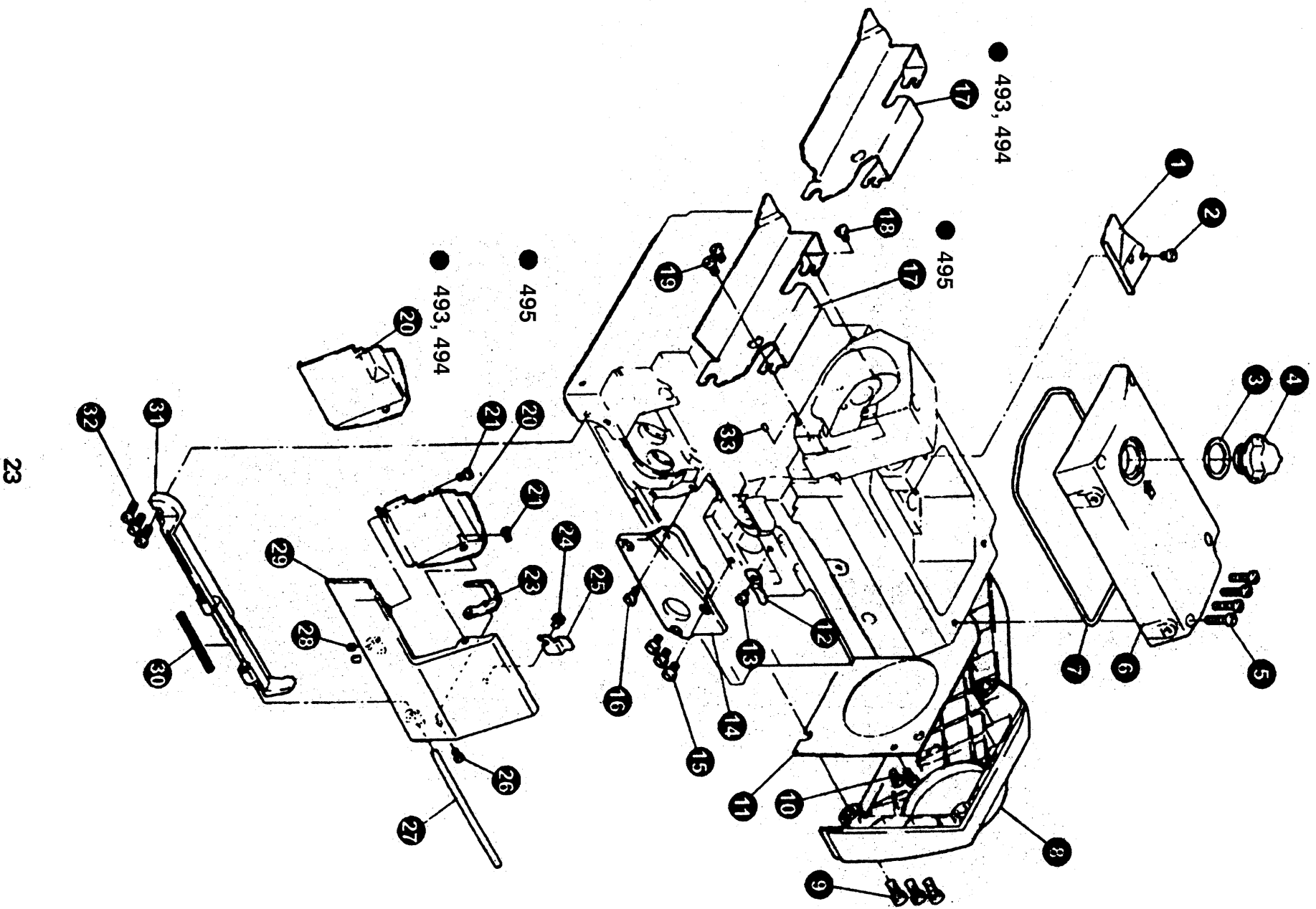

二. 机壳部件(2)/MACHINE ARM PART(2)

序号 No	图号/Ret. No.	名称/Description	件数/Ot				
			3	4	5	5H	
1	155100010	分油板	1	1	1	1	1
2	S150215008	分油板螺钉(M4 x 6)	1	1	1	1	1
3	155100031	油窗密封圈	1	1	1	1	1
4	155100030	油窗	1	1	1	1	1
5	S150215011	上盖螺钉(M4 x 18)	4	4	4	4	4
6	155100008	上盖	1	1	1	1	1
7	155100009	上盖油封	1	1	1	1	1
8	155100016	皮带罩	1	1	1	1	1
9	S150215014	皮带罩螺钉(M6 x 14)	3	3	3	3	3
10	S150215001	防护板螺钉(M4 x 8)	2	2	2	2	2
11	155100015	风扇防护板	1	1	1	1	1
12	155100013	前罩壳定位簧	1	1	1	1	1
13	S150215008	定位簧螺钉(M4 x 6)	1	1	1	1	1
14	155100014	上弯针密封板	1	1	1	1	1
15	S150215001	密封板螺钉(一)(M4 x 8)	3	3	3	3	3
16	155100034	密封板螺钉(二)	1	1	1	1	1
17	159100003	挡料板	1	1	1	1	1
18	155100011	挡料板	1	1	1	1	1
19	155100033	外六角螺钉	1	1	1	1	1
20	S150215001	挡料板螺钉(M4 x 8)	2	2	2	2	2
21	159120001	前罩壳	1	1	1	1	1
22	155120004	前罩壳	2	2	2	2	2
23	S150215008	前罩壳螺钉(M4 x 6)	1	1	1	1	1
24	155120007	前罩壳铰链导向板	1	1	1	1	1
25	S150215008	前罩壳定位板螺钉(M4 x 6)	1	1	1	1	1
26	155120005	前罩壳定位板	1	1	1	1	1
27	S120202007	前罩壳导向板螺钉(M3 x 5)	1	1	1	1	1
28	155120002	前罩壳轴	2	2	2	2	2
29	B12400432	前罩壳轴螺钉(M4 x 4)	1	1	1	1	1
30	155120001	前罩壳体	1	1	1	1	1
31	155120003	前罩壳弹簧	1	1	1	1	1
32	155120006	前罩壳铰链	1	1	1	1	1
33	S150215010	前罩壳铰链螺钉(M4 x 12)	3	3	3	3	3
	155100012	针杆回油油封	1	1	1	1	1

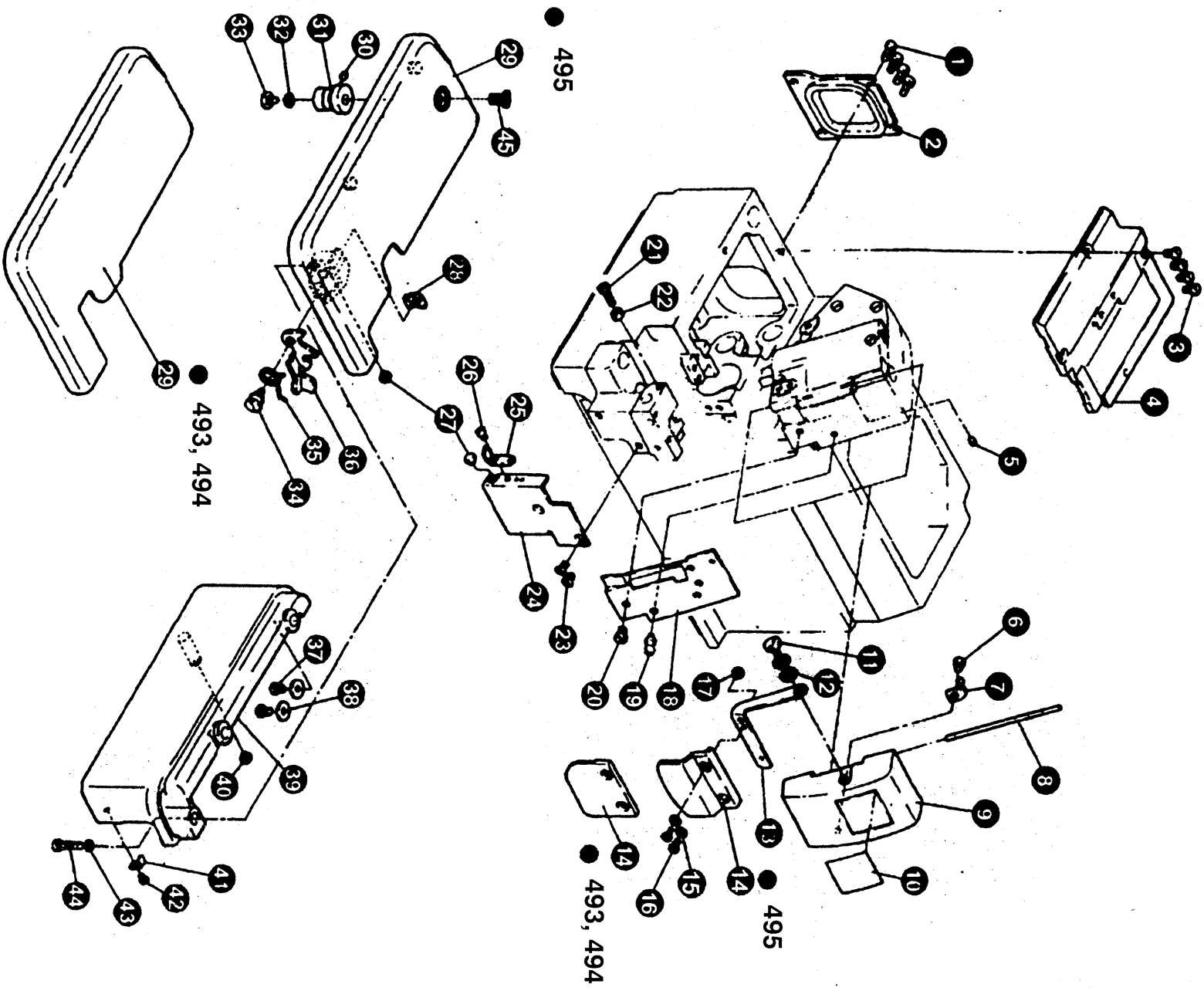

三. 机壳部件(3)/MACHINE ARM PART(3)

序号 No	图号/Ret. No.	名称/Description	件数/Qt				
			3	4	5	5H	
1	S150215009	后盖板螺钉(M4×10)	4	4	4	4	
2	155100017	后盖板	1	1	1	1	
3	155100033	下盖板螺钉	4	4	4	4	
4	155100018	缝合下盖板	1	1	1	1	
5	B12400432	机针线罩壳转轴螺钉(M4×4)	1	1	1	1	
6	S150215008	卡簧螺钉(M4×6)	1	1	1	1	
7	155100021	机针线罩壳卡簧	1	1	1	1	
8	155100020	机针线罩壳转轴	1	1	1	1	
9	155100019	机针线罩壳	1	1	1	1	
10	155100028	前装饰牌	1	1	1	1	
11	155100024	支架轴位螺钉	1	1	1	1	
12	155100025	波形圈	2	2	2	2	
13	155100023	观察板支架	1	1	1	1	
14	159100004	观察板	1	1	1	1	
15	155100026	观察板	2	2	2	2	
16	S8A3103002	观察板垫圈 3	2	2	2	2	
17	S120202007	观察板螺钉(M3×5)	1	1	1	1	
18	155100027	观察板橡皮塞	1	1	1	1	
19	155100029	针杆挡油板	1	1	1	1	
20	155100022	机针线罩壳锁紧柱	1	1	1	1	
	155100034	针杆挡油板螺钉	1	1	1	1	

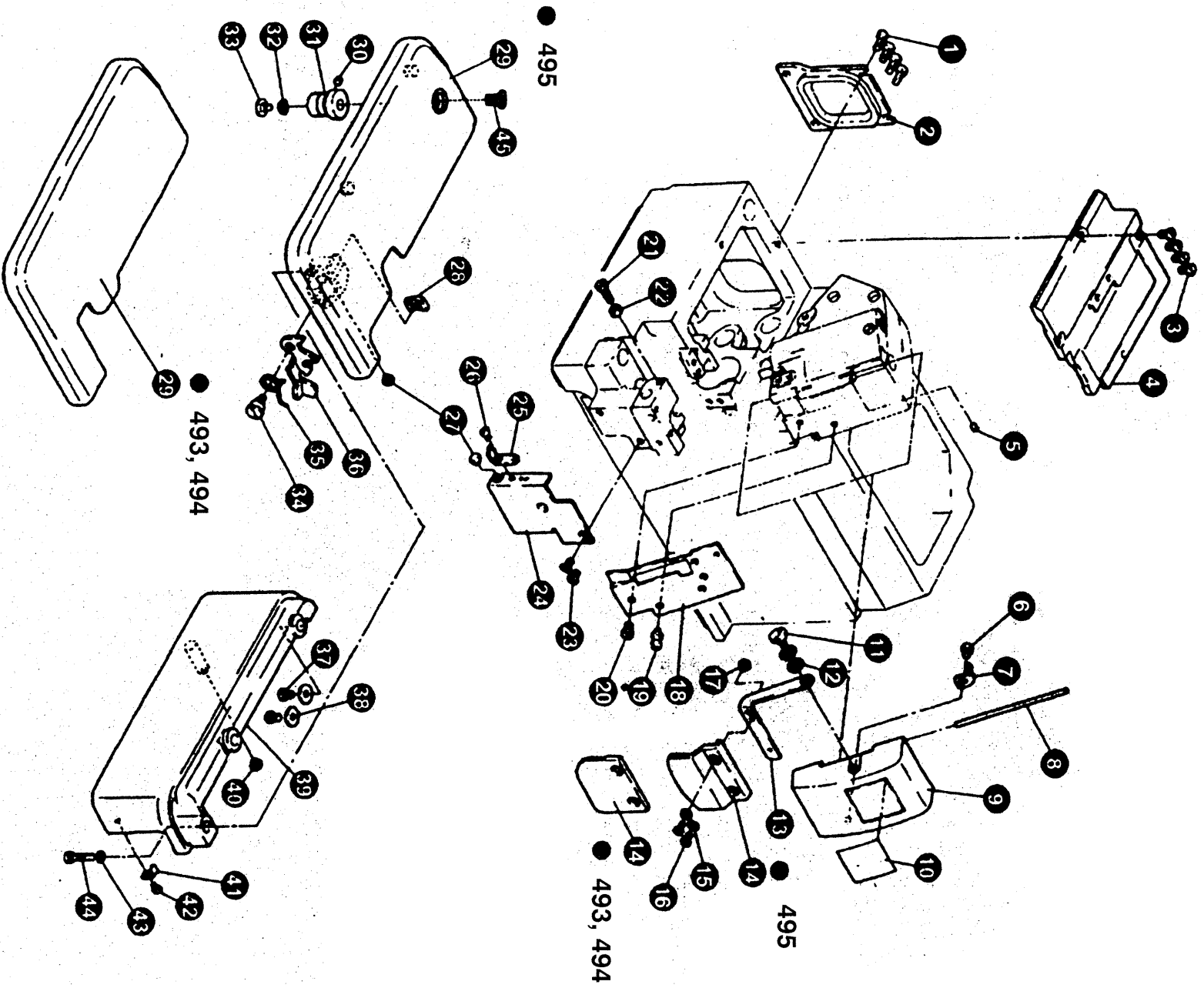

三. 机壳部件(3)/MACHINE ARM PART(3)

序号 No	图号/Ret. No.	名称/Description	件数/Qt				
			3	4	5	5H	
21	S150215005	缝台定位螺钉(M4×16)	1	1	1	1	
22	S150559002	缝台定位螺母(M4)	1	1	1	1	
23	S150218005	导向板螺钉(M4×6)	2	2	2	2	
24	155140001	导向板	1	1	1	1	
25	155140002	锁紧簧	1	1	1	1	
26	S150217008	锁紧簧螺钉(M3.5×4)	3	3	3	3	
27	155100027	防震塞头	1	1	1	1	
28	155130006	缝台簧座螺母	1	1	1	1	
29	159131001	缝台	1	1	1	1	
30	155131001	缝台	1	1	1	1	
31	B12400432	缝台转轴螺钉(M4×4)	1	1	1	1	
32	155130001	缝台转轴套	1	1	1	1	
33	155100025	波形垫圈	1	1	1	1	
34	155100024	缝台转轴套螺钉	1	1	1	1	
35	155130005	锁门螺钉	1	1	1	1	
36	155130004	锁门簧	1	1	1	1	
37	155130003	缝台锁门扳手	2	2	2	2	
38	S150215008	下罩壳螺钉(M4×6)	2	2	2	2	
39	155130008	下罩壳螺钉垫圈	2	2	2	2	
40	155130007	下罩壳	1	1	1	1	
41	155100027	防震塞头	1	1	1	1	
42	155130009	缝台卡簧	1	1	1	1	
43	S120202004	缝台卡簧螺钉(M3×4)	1	1	1	1	
44	S4B3000010	弹簧垫圈 4	1	1	1	1	
45	S150215015	下罩壳长螺钉(M4×20)	1	1	1	1	
	116400008	螺钉	1	1	1	1	

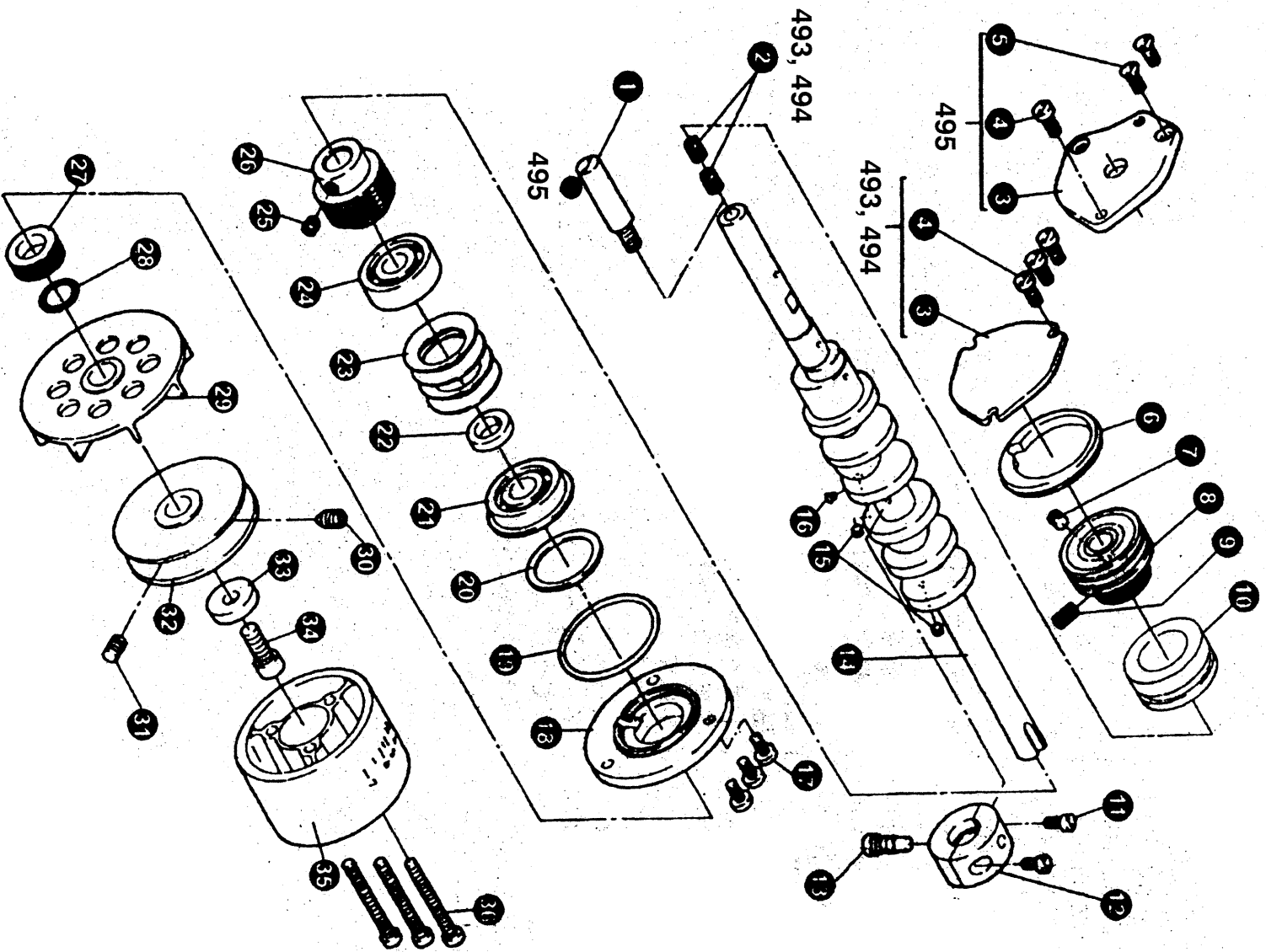

四. 针杆传动部件(1)/NEEDLE BAR DRIVE PARTS(1)

序号 No	图号/Ret. No.	名称/Description	件数/Qt				
			3	4	5	5H	
1	155200001	主轴接头			1	1	
2	S150224007	主轴封油螺钉(M6×5)	2	2			
3	159200001	主轴前端密封盖	1	1			
3	155200002	主轴前端密封盖			1	1	
4	S150215009	密封盖螺钉(M4×10)	3	3			
5	S150215009	密封盖螺钉(M4×10)			1	1	
6	S120205003	沉头螺钉(M4×8)			2	2	
6	155200004	密封圈	1	1	1	1	
7	B12500532	棘轮螺钉(M5×5)	1	1	1	1	
8	155220000	主轴左轴承组件	1	1	1	1	
9	S150224006	棘轮长螺钉(M5×10)	1	1	1	1	
10	155200005	主轴中轴套	1	1	1	1	
11	SFB0201004	定位轴套紧固螺钉(M3.5×8)	2	2	2	2	
12	155230001	主轴定位轴套	1	1	1	1	
13	155200006	主轴定位螺钉	1	1	1	1	
14	155210001	主轴	1	1	1	1	
15	006301008	曲拐封油螺钉	2	2	2	2	
16	028260003	轴肩封油螺钉	1	1	1	1	
17	S150215009	止动盖螺钉(M4×10)	3	3	3	3	
18	155200011	轴承止动盖	1	1	1	1	
19	028200013	O型密封圈	1	1	1	1	
20	155200010	密封垫片	1	1	1	1	
21	052200036	主轴右轴承组件(6201-RS)	1	1	1	1	
22	155200009	主轴碟形圈套筒	1	1	1	1	
23	155200008	主轴碟形圈	4	4	4	4	
24	052200035	主轴中轴承 201	1	1	1	1	
25	B12500532	蜗杆螺钉(M5×5)	1	1	1	1	
26	155200007	油泵蜗杆	1	1	1	1	
27	155200012	主轴封油螺圈	1	1	1	1	
28	S150656004	O型密封圈(11.8×2.65)	1	1	1	1	
29	155200013	冷却风扇	1	1	1	1	
30	S150225003	皮带轮定位螺钉(M6×10)	1	1	1	1	
31	S150224003	皮带轮紧固螺钉(M6×8)	1	1	1	1	
32	155200014	主轴皮带轮	1	1	1	1	
33	155200016	垫圈	1	1	1	1	
34	S150220005	皮带轮吊紧螺钉(M6×16)	1	1	1	1	
35	155200017	上轮	1	1	1	1	
36	S150215012	上轮螺钉(M4×40)	3	3	3	3	

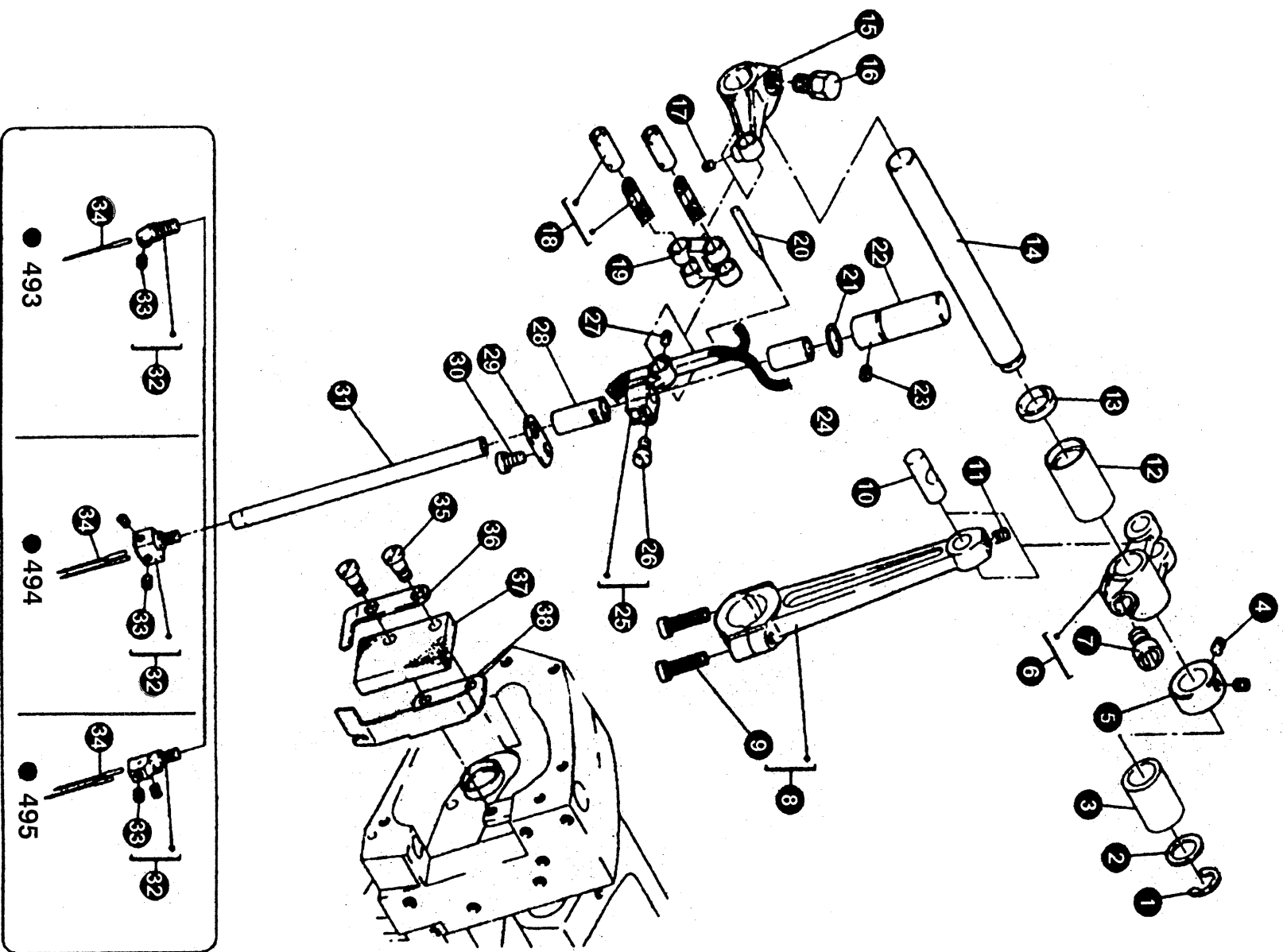

五. 针杆传动部件(2)/NEEDLE BAR DRIVE PARTS(2)

序号 No	图号/Ret. No.	名称/Description	件数/Qt				
			3	4	5	5H	
1	060410014	开口挡圈 7	1	1	1	1	
2	155300006	上轴垫片	1	1	1	1	
3	155300005	上轴右轴套	1	1	1	1	
4	B12400432	紧圈螺钉(M4 x 4)	2	2	2	2	
5	155300004	上轴紧圈	1	1	1	1	
6	155310000	上轴曲柄组件	1	1	1	1	
7	155370000	上轴曲柄组件	1	1	1	1	
8	155300017	曲柄螺钉	1	1	1	1	
9	155330000	上轴球连杆组件	1	1	1	1	
10	B62401612	球连杆螺钉(4 x 16)	2	2	2	2	
11	155300023	连杆销	1	1	1	1	
12	S1502224009	连杆销螺钉(M4 x 6)	1	1	1	1	
13	155300002	上轴左轴套	1	1	1	1	
14	155300003	上轴左轴套油封	1	1	1	1	
15	155300007	上轴	1	1	1	1	
16	155400010	针杆曲柄	1	1	1	1	
17	S150221001	针杆曲柄螺钉	1	1	1	1	
18	155320000	连杆销支紧螺钉(M3 x 4)	1	1	1	1	
19	155300008	针杆连杆销组件	2	2	2	2	
20	155300012	针杆连杆	1	1	1	1	
21	S150656005	油线固定销	1	1	1	1	
22	155300014	O型密封圈(8.5 x 1.8)	1	1	1	1	
23	B12400432	针杆上套筒	1	1	1	1	
24	155300013	上套筒螺钉(M4 x 4)	1	1	1	1	
25	155300010	针杆上轴套	1	1	1	1	
26	SFB0201004	针杆接头	1	1	1	1	
27	S150221001	针杆支紧螺钉(M3.5 x 8)	1	1	1	1	
28	155300015	连杆下轴套	1	1	1	1	
29	155300016	针杆回油板	1	1	1	1	
30	S150215008	回油板螺钉(M4 x 6)	1	1	1	1	
31	155350001	针杆	1	1	1	1	
32	160320001	针夹	1	1	1	1	
33	159320001	针夹	1	1	1	1	
34	155350002	针夹	1	1	1	1	
35	182610010	支针螺钉	1	2	2	2	
36	159300007	机针 DC x 27 11#	1	2	2	2	
37	028280109	机针 DC x 27 14#	1	2	2	2	
38	077200401	机针 DC x 27 21#	1	2	2	2	
	155300021	油毡螺钉	2	2	2	2	
	155300020	油毡压板	1	1	1	1	
	155300019	针杆油毡	1	1	1	1	
	155300022	防油板	1	1	1	1	

● 495

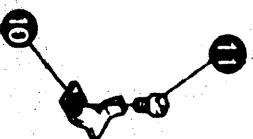
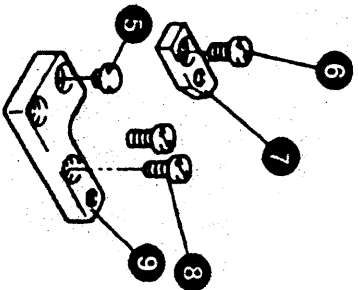
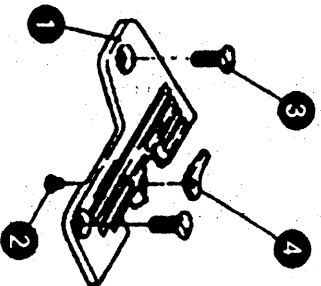
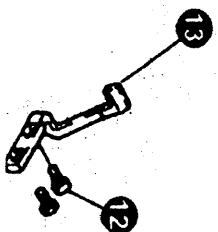
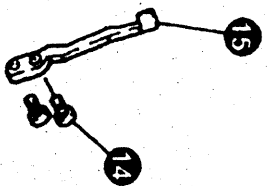
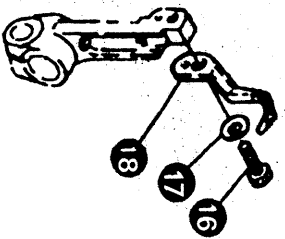

● 493, 494

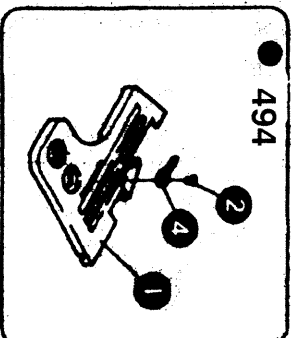
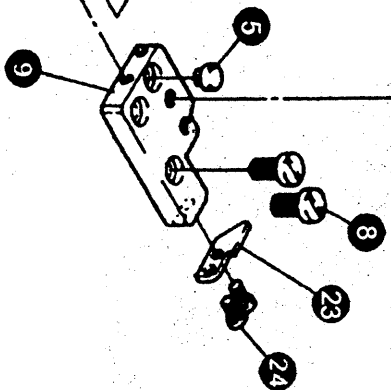
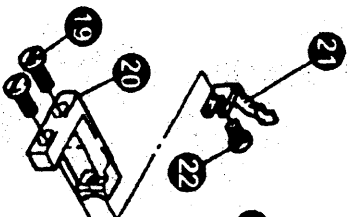
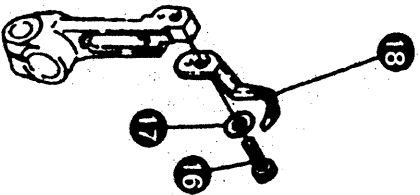
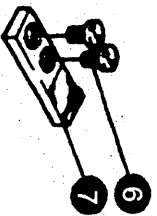

● 494

六. 针杆传动部件(3) / NEEDLE BAR DRIVE PARTS(3)

序号 No	图号/Ret. No.	名称/Description	件数/Qt				
			3	4	5	5H	
1	160300001	针板 针板(三排齿)	1				
	160300003	针板		1			
	159310001	针板			1		
	155340001	针板				1	
2	155380001	针板					
	159310003	针板小舌头螺钉		1			1
	039230003	针板舌头螺钉					
3	159300006	针板螺钉		2			
	028200050	针板螺钉			2		
4	159310002	针板小舌头				2	2
	155340002	针板舌头					
	155380002	针板舌头					
5	155100027	缝台防震塞					1
6	B62400812	紧固螺钉(M4×8)		1	1	1	1
	B62400812	紧固螺钉(M4×8)		2	2		
7	159330000	针板垫块(后)组件					
	155300029	针板垫块(后)		1	1		1
8	B62401012	紧固螺钉(M4×10)					1
	B62401012	紧固螺钉(M4×10)		2	2		
9	159300004	针板垫块(前)					2
	155300028	针板垫块(前)		1			2
10	155300027	前直针前护针板					1
11	S150217002	前护针板螺钉(M3×6)					1
12	S120202001	后护针板螺钉(M2.5×5)					1
13	155300026	前直针后护针板					2
14	S150217002	后直针前护针板螺钉(M3×6)					2
15	155300025	后直针前护针板					2
16	028200054	下弯针后保针板螺钉					1
17	SFB0601003	下弯针后保针板垫圈		1	1		1
18	155300024	前护针板架					1
19	110550005	前护针板架螺钉(M3.5×13)					1
20	159300002	前护针板		2			2
21	159300001	前护针板					1
22	SFB0201003	后直针前护针板螺钉(M3.5×6)					1
23	159300005	针板导向板					1
24	SFB0201004	针板导向板螺钉(M3.5×8)					2

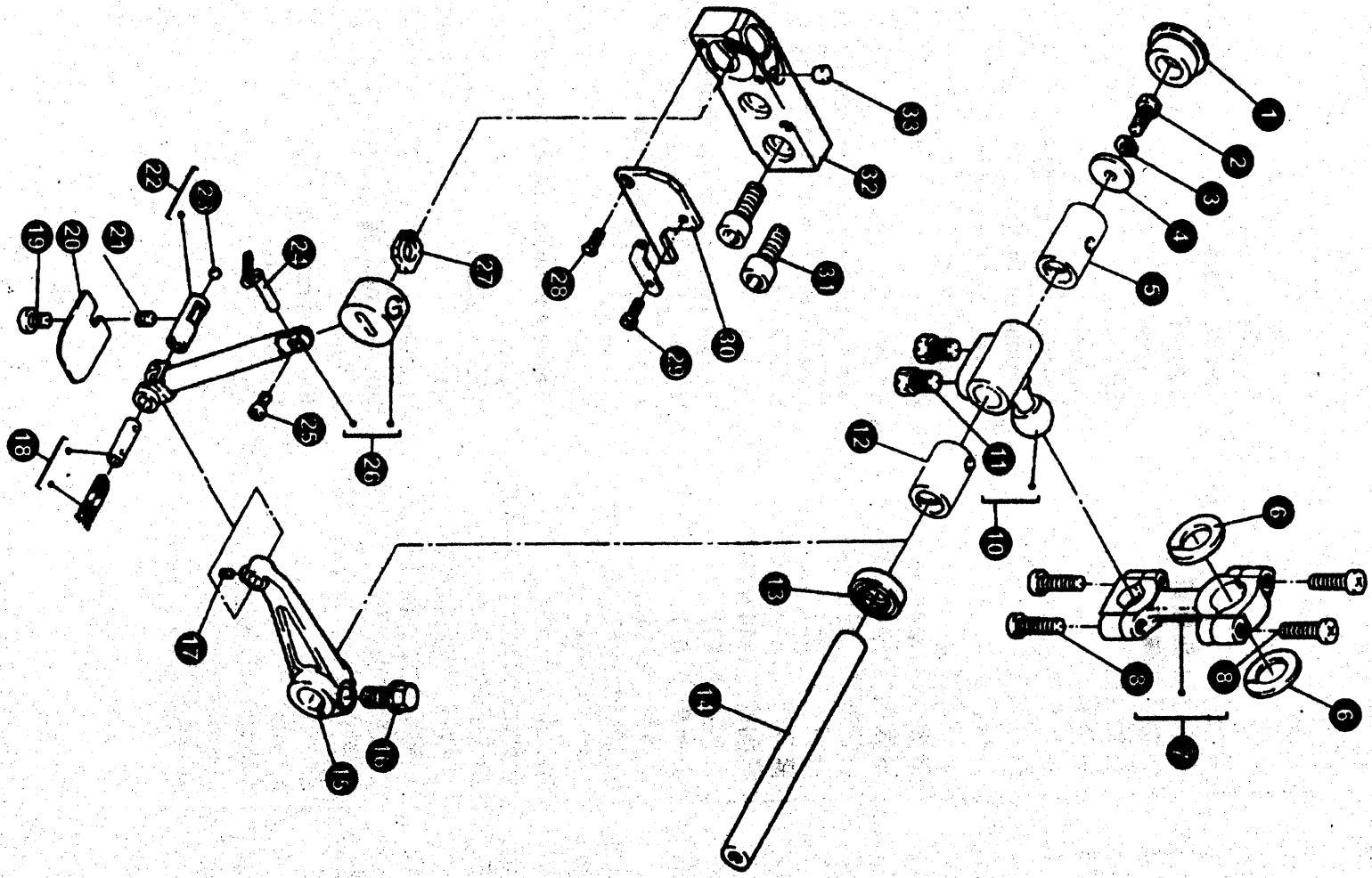

七. 上下弯针传动部件(1)/UPPER AND LOWER LOOPER DRIVE PART(1)

序号 No	图号/Ret. No.	名称/Description	件数/Qt				
			3	4	5	5H	
1	155400006	上弯针轴后橡皮塞	1	1	1	1	
2	S150204002	吊紧螺钉(M5×10)	2	2	2	2	
3	S8A3103012	弹簧垫圈 5	2	2	2	2	
4	155400005	上下弯针轴垫圈	1	1	1	1	
5	155400004	上弯针轴后轴套	1	1	1	1	
6	155400001	球连杆止摆垫圈	2	2	2	2	
7	155410000	弯针球连杆组件	1	1	1	1	
8	B62401612	连杆螺钉(M4×16)	1	1	1	1	
10	155420000	上弯针球曲柄组件	4	4	4	4	
11	159400002	上弯针球曲柄组件	1	1	1	1	
12	155400021	弯针球曲柄螺钉	2	2	2	2	
13	028330001	弯针轴前轴套	1	1	1	1	
14	155400002	上下弯针轴	1	1	1	1	
15	155400009	上弯针曲柄	1	1	1	1	
16	155400010	上弯针曲柄夹紧螺钉	1	1	1	1	
17	S150221001	支紧螺钉(M3×4)	1	1	1	1	
18	155430000	上弯针夹紧轴销组件	1	1	1	1	
19	S150215008	挡油板螺钉(M4×6)	1	1	1	1	
20	155400014	上弯针夹紧轴挡油板	1	1	1	1	
21	B12400432	供油销支紧螺钉(M4×4)	1	1	1	1	
22	155440000	上弯针夹紧轴供油销组件	1	1	1	1	
23	S8A3105006	小钢球 4	1	1	1	1	
24	160400001	上弯针	1	1	1	1	
	159400001	上弯针					
	155400015	上弯针	1				
	155400025	上弯针		1			
25	028100007	上弯针夹紧螺钉	1	1	1	1	
26	155400011/12	上弯针夹紧轴/导架	1	1	1	1	
27	155400013	夹紧轴导架油毡	1	1	1	1	
28	S150218001	导架座挡板螺钉(M2.5×6)	1	1	1	1	
29	S150217011	小过线螺钉(M2.5×8)	1	1	1	1	
30	155400016	导架座挡板	1	1	1	1	
31	S150220005	导架座螺钉(M6×16)	1	1	1	1	
32	155400007	上弯针夹紧轴导架座	2	2	2	2	
33	155400008	导架座回油毡	1	1	1	1	

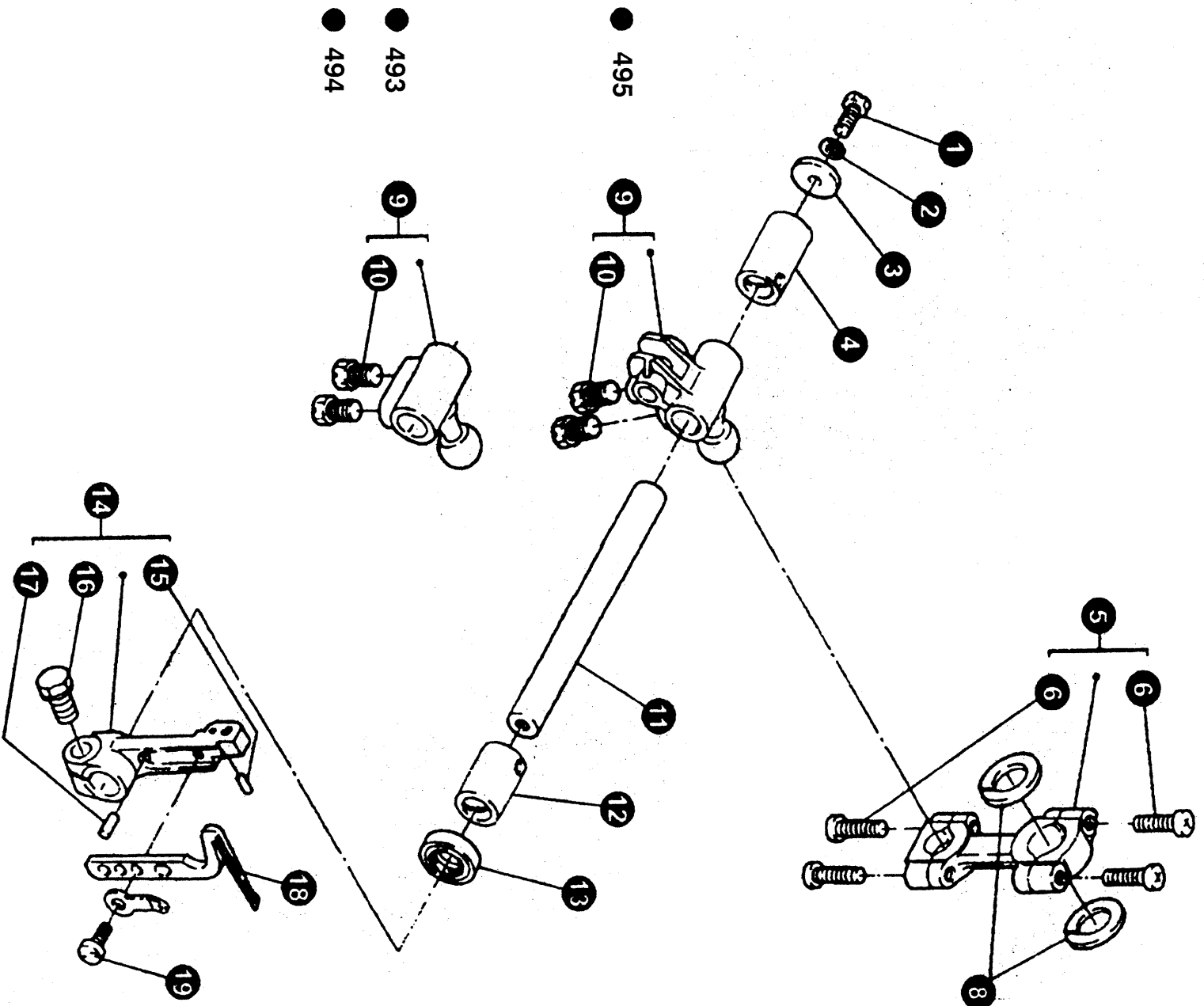

八. 上下弯针传动部件(2) / UPPER AND LOWER LOOPER DRIVE PART(2)

序号 No	图号 / Ret. No.	名称 / Description	件数 / Qt				
			3	4	5	5H	
1	S150204002	吊紧螺钉(M5 x10)	1	1	1	1	
2	S8A3103012	弹簧垫圈 5	1	1	1	1	
3	155400005	上下弯针轴垫圈	1	1	1	1	
4	155400020	下弯针轴后轴套	1	1	1	1	
5	155410000	弯针球连杆组件	1	1	1	1	
6	B62401612	连杆螺钉(M4 x16)	1	1	1	1	
8	155400001	球连杆止摆垫圈	4	4	4	4	
9	159400002	下弯针球曲柄	2	2	2	2	
10	155400019	下弯针球曲柄	1	1	1	1	
11	155400002	上下弯针轴	2	2	2	2	
12	155400003	弯针轴前轴套	1	1	1	1	
13	028330001	弯针轴油封	1	1	1	1	
14	155451000	下弯针架小组件	1	1	1	1	
15	028300043	后保针板定位销	1	1	1	1	
16	155400010	下弯针架夹紧螺钉	1	1	1	1	
17	028300046	下弯针定位销	1	1	1	1	
18	155450002	下弯针	1	1	1	1	
19	028100027	下弯针螺钉	1	1	1	1	

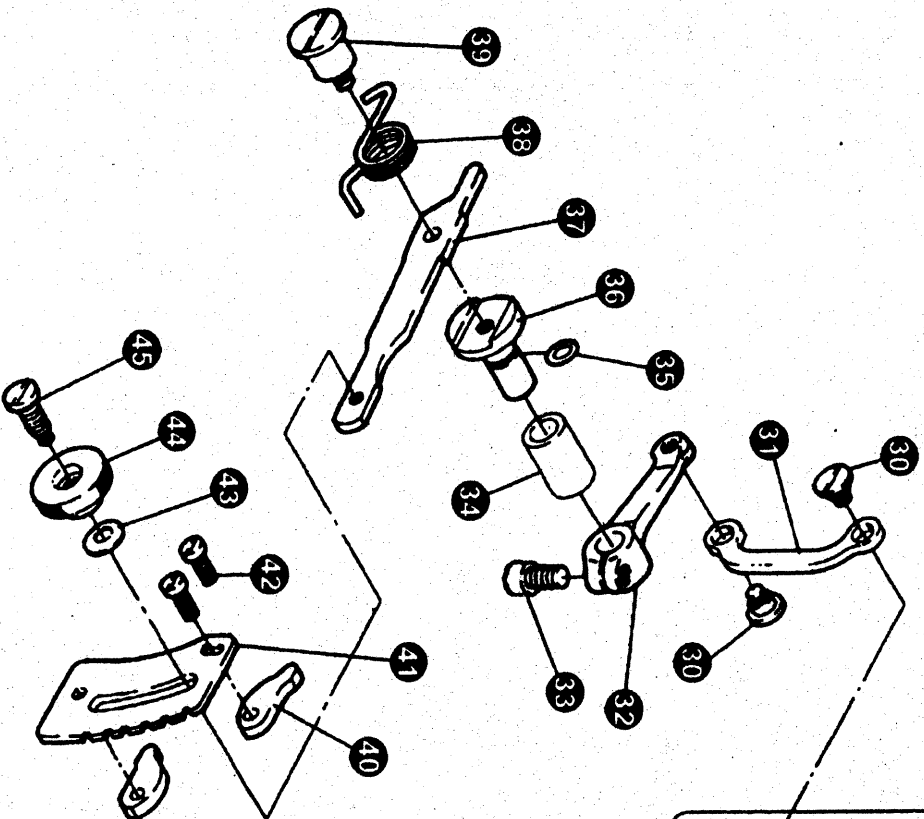
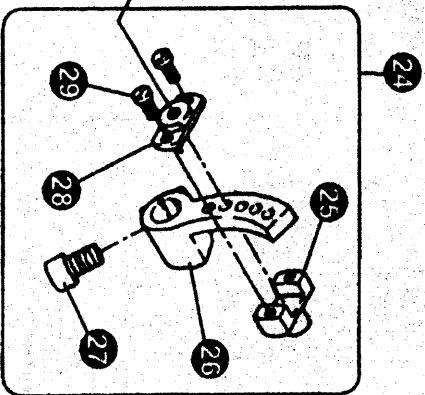
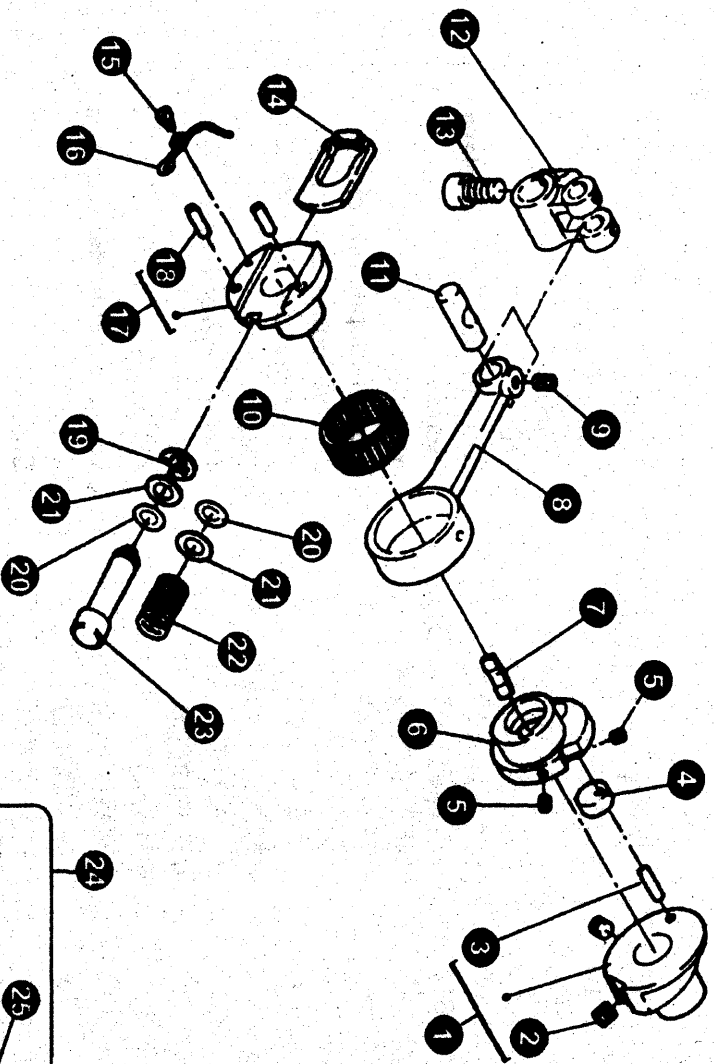

九. 拾牙送布部件(1)/FEED DOG LIFT PART(1)

序号 No	图号/Ret. No.	名称/Description	件数/Ot				
			3	4	5	5H	
1	155530000	送布凸轮座组件	1	1	1	1	
2	B12500532	送布凸轮座支紧螺钉(M5 x5)	2	2	2	2	
3	028400082	送布凸轮座销	1	1	1	1	
4	028400080	送布凸轮偏心滚柱	1	1	1	1	
5	S1502222001	送布凸轮簧螺钉(M3 x6)	2	2	2	2	
6	155500026	送布凸轮	1	1	1	1	
7	155500027	送布凸轮簧	1	1	1	1	
8	155500028	送布连杆	1	1	1	1	
9	S150224009	箱支紧螺钉(M4 x6)	1	1	1	1	
10	155540000	送布连杆滚针轴承	1	1	1	1	
11	155300023	送布连杆销	1	1	1	1	
12	155500029	送布曲柄	1	1	1	1	
13	155300017	送布曲柄夹紧螺钉	1	1	1	1	
14	155500030	针距调节滑块	1	1	1	1	
15	155500032	调节滑块锁紧簧螺钉	1	1	1	1	
16	155500031	调节滑块锁紧簧	1	1	1	1	
17	155550000	针距凸轮组件	1	1	1	1	
18	S150446010	圆柱弹性销(2.5 x10)	2	2	2	2	
19	S8A3103018	开口挡圈 6	1	1	1	1	
20	S4A0604005	O 型圈(6.3 x1.8)	2	2	2	2	
21	155500035	针距调节杆垫圈	2	2	2	2	
22	155500034	针距调节簧	1	1	1	1	
23	155500033	针距调节杆	1	1	1	1	
24	155560000	差动牙调整曲柄组件	1	1	1	1	
25	155560002	差动座	1	1	1	1	
26	155560001	差动牙调整曲柄	1	1	1	1	
27	155300017	差动牙调整曲柄夹紧螺钉	1	1	1	1	
28	155560003	差动座盖	1	1	1	1	
29	S150217012	差动座盖螺钉(M3 x8)	2	2	2	2	
30	155500037	差动调节拉杆轴位螺钉	2	2	2	2	
31	155500036	差动调节拉杆	1	1	1	1	
32	155500038	差动调节拉杆曲柄	1	1	1	1	
33	155300017	差动调节拉杆曲柄夹紧螺钉	1	1	1	1	
34	155500040	拉杆曲柄轴轴套	1	1	1	1	
35	S4A0604005	拉杆曲柄轴 O 型圈(6.3 x1.8)	1	1	1	1	
36	155500039	拉杆曲柄轴	1	1	1	1	
37	155500041	差动扳手	1	1	1	1	
38	155500042	差动扳手扭簧	1	1	1	1	
39	155500043	差动扳手螺钉	1	1	1	1	
40	155500044	差动扳手定位板	2	2	2	2	
41	155500045	差动刻度板	1	1	1	1	
42	S150215010	差动刻度板螺钉(M4 x12)	2	2	2	2	
43	028400044	差动扳手调节垫圈	1	1	1	1	
44	155500046	差动扳手调节螺母	1	1	1	1	
45	155500047	差动扳手调节螺钉	1	1	1	1	

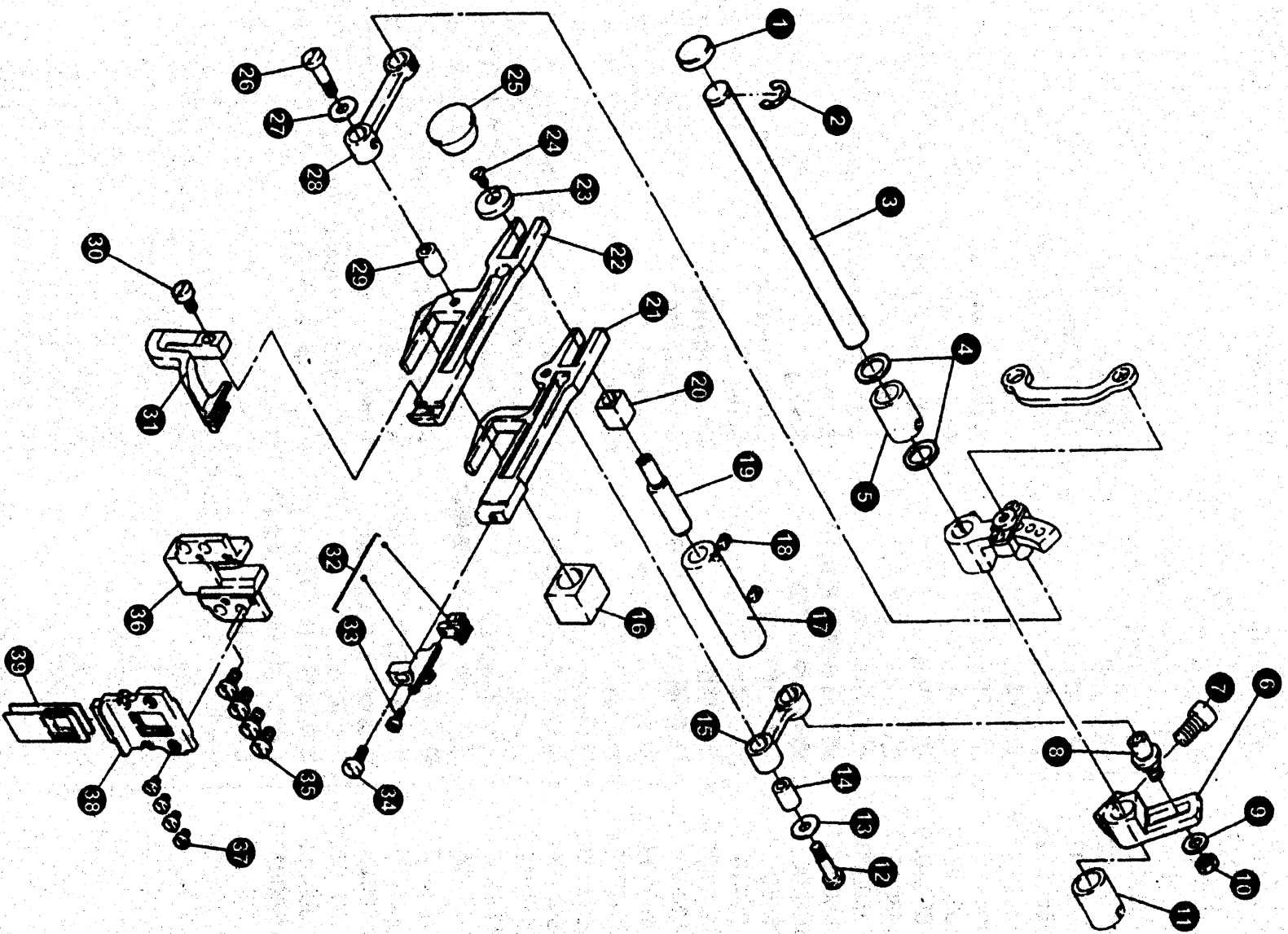

十. 抬牙送布部件(2) / FEED DOG LIFT PART(2)

序号 No	图号/Ret. No.	名称/Description	件数/Qt				
			3	4	5	5H	
1	028310001	送布轴孔油封					
2	060410014	开口挡圈 7	1	1	1	1	
3	155500001	送布轴	1	1	1	1	
4	155300006	垫片	1	1	1	1	
5	155500003	送布轴左轴套	2	2	2	2	
6	155500005	送布调整曲柄	1	1	1	1	
7	155300017	送布调整曲柄夹紧螺钉	1	1	1	1	
8	155500006	送布牙架连杆轴	1	1	1	1	
9	155500010	整圈 4	1	1	1	1	
10	S150559002	螺母(M4)	1	1	1	1	
11	155500004	送布轴右轴套	1	1	1	1	
12	028400023	滚柱螺钉	1	1	1	1	
13	155500010	滚柱垫圈	1	1	1	1	
14	028400021	送布牙架连杆滚柱	1	1	1	1	
15	155500008	送布牙架连杆	1	1	1	1	
16	155500019	抬牙滑块	1	1	1	1	
17	155500014	滑块偏心轴轴套	1	1	1	1	
18	B12400432	支紧螺钉(M4×4)	1	1	1	1	
19	028400055	滑块偏心轴	2	2	2	2	
20	155500012	差动送布滑块	1	1	1	1	
21	155510001	送布牙架	1	1	1	1	
22	155510002	差动牙架	1	1	1	1	
23	028400058	差动送布滑块垫圈	1	1	1	1	
24	028400059	垫圈螺钉	1	1	1	1	
25	155500017	滑块偏心轴孔油封	1	1	1	1	

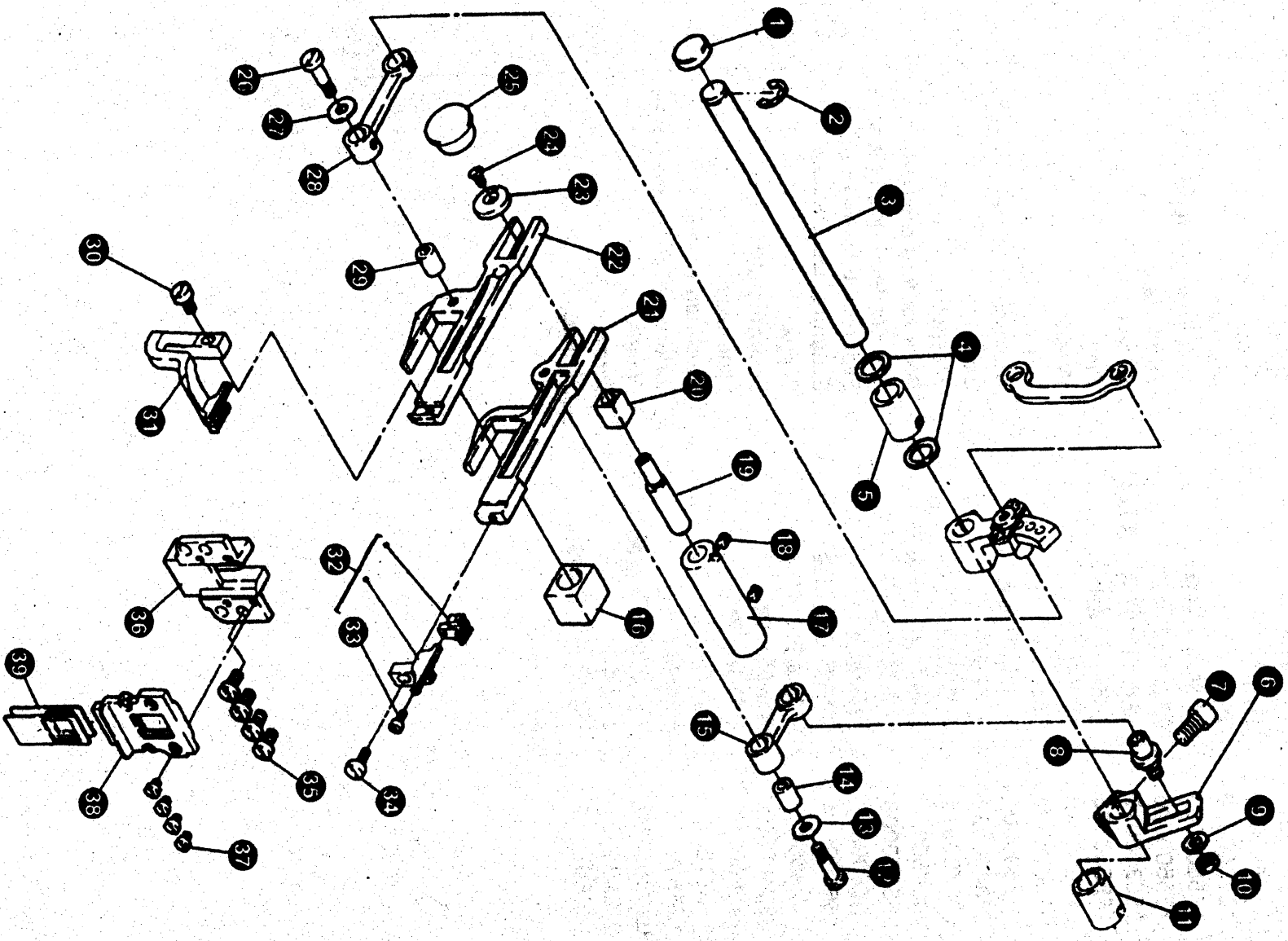

十. 抬牙送布部件(2)/FEED DOG LIFT PART(2)

序号 No	图号/Ret. No.	名称/Description	件数/Qt				
			3	4	5	5H	
26	028400023	滚柱螺钉	1	1	1	1	
27	155500010	滚柱垫圈	1	1	1	1	
28	155500018	差动牙架连杆	1	1	1	1	
29	028400021	送布牙架连杆滚柱	1	1	1	1	
30	028200056	差动牙螺钉	1	1	1	1	
	028100027	差动牙螺钉	1	1	1	1	
31	155500021	差动牙	1	1	1	1	
	155500050	差动牙				1	
	160500001	差动牙					
	159500001	差动牙	1	1			
32	159500001	差动牙(三排齿)					
	155580000	主送布牙组件				1	
	155580001	主送布牙				1	
32	155520002	副送布牙				1	
	155520000	主送布牙组件				1	
	155520001	主送布牙				1	
32	155520002	副送布牙				1	
	159510000	主送布牙组件				1	
	159510001	主送布牙				1	
32	159510002	副送布牙				1	
	160510000	主送布牙组件				1	
	160510001	主送布牙				1	
33	159510000	主送布牙组件(三排齿)				1	
34	028400004	副送布牙螺钉	1	1	1	1	
	028100027	送布牙螺钉	1	1	1	1	
35	S150215001	差动送布导板螺钉(M4 x8)	4	4	4	4	
	155500023	差动送布导板	1	1	1	1	
36	S120202007	密封导板螺钉(M3 x5)	4	4	4	4	
	155500024	差动送布密封导板	1	1	1	1	
38	155500025	差动送布密封板	2	2	2	2	
39	155500025	差动送布密封板	2	2	2	2	

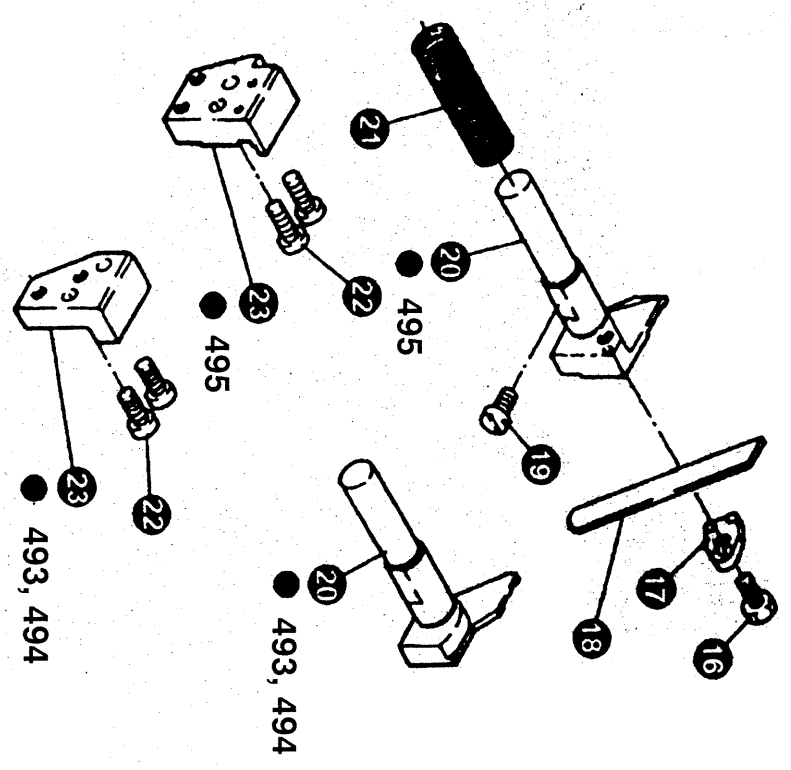
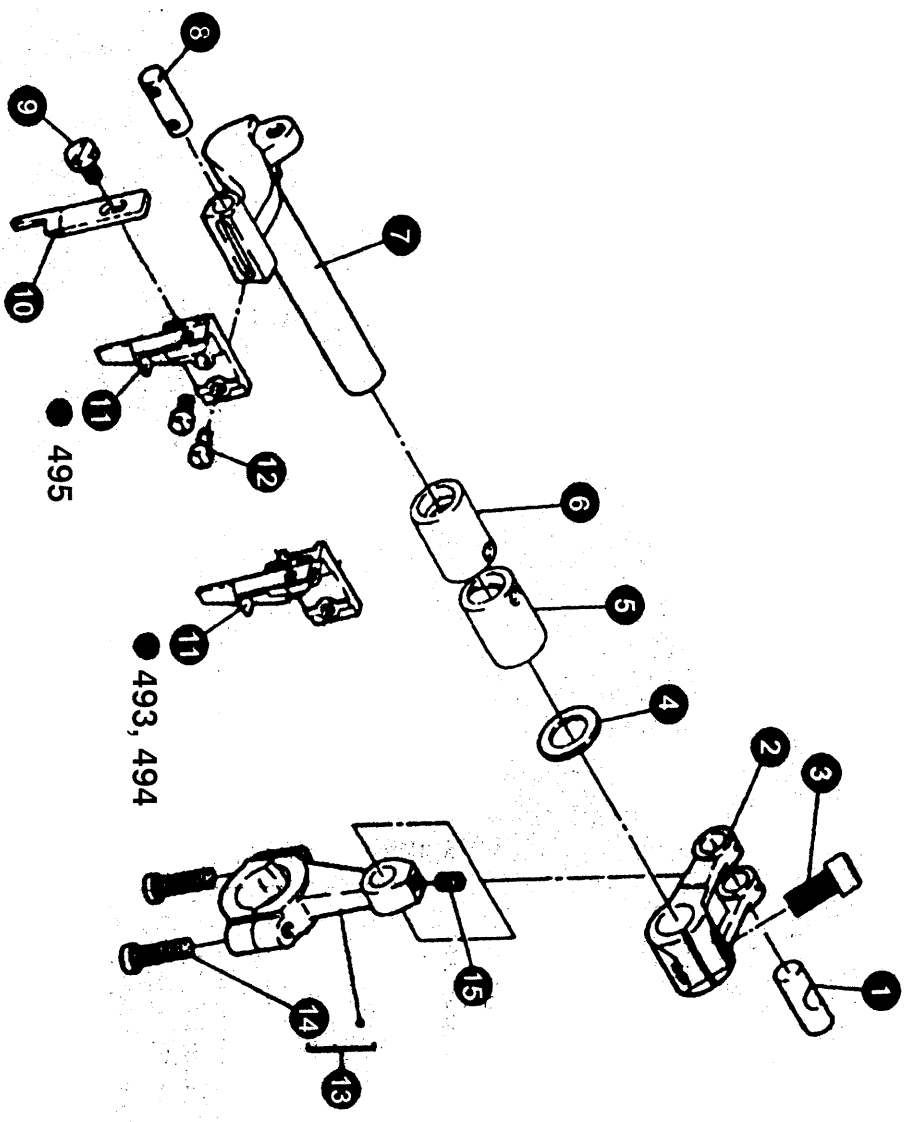

十一. 切刀传动部件/CUTTER DRIVE PARTS

序号 No	图号/Ret. No.	名称/Description	件数/Qt				
			3	4	5	5H	
1	155300023	上切刀传动曲柄销	1	1	1	1	
2	155600001	上切刀传动曲柄	1	1	1	1	
3	1553300017	上切刀传动曲柄夹紧螺钉	1	1	1	1	
4	1556000002	上切刀传动曲柄垫圈	1	1	1	1	
5	1556000005	上切刀杆右轴套	1	1	1	1	
6	1556000004	上切刀杆左轴套	1	1	1	1	
7	1556000003	上切刀杆	1	1	1	1	
8	1556000006	上切刀销	1	1	1	1	
9	1596000001	上切刀销	1	1	1	1	
9	1556000013	上切刀紧定螺钉	1	1	1	1	
10	1556000008	上切刀	1	1	1	1	
11	1596000002	上切刀架	1	1	1	1	
11	1556000007	上切刀架	1	1	1	1	
12	B60350812	上切刀架螺钉(M3.5×8)	2	2	2	2	
13	155610000	上切刀传动连杆组件	1	1	1	1	
14	B62401612	连杆螺钉(M4×16)	2	2	2	2	
15	S150224009	曲柄销支紧螺钉(M4×6)	1	1	1	1	
16	028300027	下切刀紧定螺钉	1	1	1	1	
17	028500013	下切刀夹	1	1	1	1	
18	1596000004	下切刀	1	1	1	1	
18	1556000011	下切刀	1	1	1	1	
19	S150215001	下切刀架紧定螺钉(M4×8)	1	1	1	1	
20	1596000003	下切刀架	1	1	1	1	
20	1556000009	下切刀架	1	1	1	1	
21	1556000010	下切刀架弹簧	1	1	1	1	
22	S150215010	护针板架螺钉(M4×12)	2	2	2	2	
22	1556000012	护针板架	1	1	1	1	
23	1596000005	护针板架	1	1	1	1	

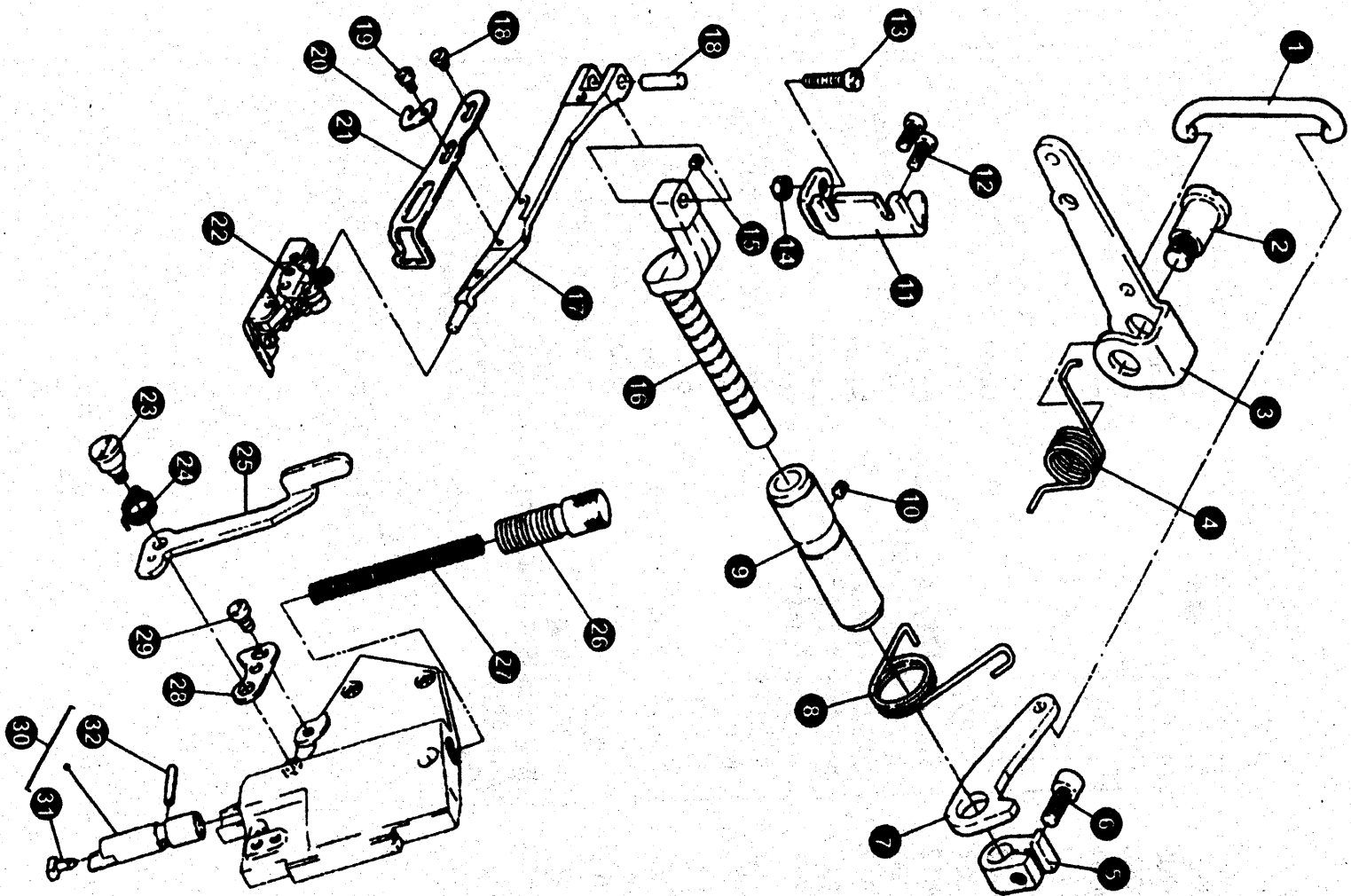

十二. 拾牙脚部件(1)/PRESSER FOOT LIFT PARTS(1)

序号 No	图号/Ret. No.	名称/Description	件数/Qt				
			3	4	5	5H	
1	155800011	联接杆	1	1	1	1	
2	155800010	拾压脚杠杆螺钉	1	1	1	1	
3	155800008	拾压脚杠杆杆	1	1	1	1	
4	155800009	拾压脚杠杆簧	1	1	1	1	
5	155800007	拾压脚轴紧固圈	1	1	1	1	
6	155300017	拾压脚轴紧固圈螺钉	1	1	1	1	
7	155800005	中间杠杆杆	1	1	1	1	
8	155800006	中间杠杆杆扭簧	1	1	1	1	
9	155800004	拾压脚轴套	1	1	1	1	
10	B12400432	拾压脚轴套螺钉(M4 x4)	1	1	1	1	
11	155800012	拾压脚杠杆限位板	1	1	1	1	
12	S150215009	限位板紧固螺钉(M4 x10)	2	2	2	2	
13	S150215013	拾压脚杠杆限位螺钉(M5 x25)	1	1	1	1	
14	S120503010	拾压脚杠杆限位螺母(M5)	1	1	1	1	
15	S120210015	压脚臂轴支系螺钉(M4 x0.5 x3.5)	1	1	1	1	
16	155800003	拾压脚轴	1	1	1	1	
17	155800001	压脚臂	1	1	1	1	
18	155800002	压脚臂销	1	1	1	1	
19	S120202004	护指板螺钉(M3 x4)	1	1	1	1	
20	S120202007	割线刀螺钉(M3 x5)	1	1	1	1	
21	159700001	护指板	1	1	1	1	
22	155800019	护指板	1	1	1	1	
	160710000	压脚组件	1				
	160730000	压脚组件(三排齿)	1				
	159710000	压脚组件	1	1			
	039720000	压脚组件			1		
	7777-001A	压脚组件				1	
23	155800018	压脚扳手轴位螺钉	1	1	1	1	
24	155800017	压脚扳手扭簧	1	1	1	1	
25	155800016	压脚扳手	1	1	1	1	
26	155800013	调压螺钉	1	1	1	1	
27	155800014	压紧杆弹簧	1	1	1	1	
28	155800015	压脚提升定位片	1	1	1	1	
29	S150215008	定位片螺钉(M4 x6)	1	1	1	1	
30	155810000	压紧杆组件	1	1	1	1	
31	155810002	缓冲垫	1	1	1	1	
32	S150446011	圆柱弹性销(3 x18)	1	1	1	1	

● 495

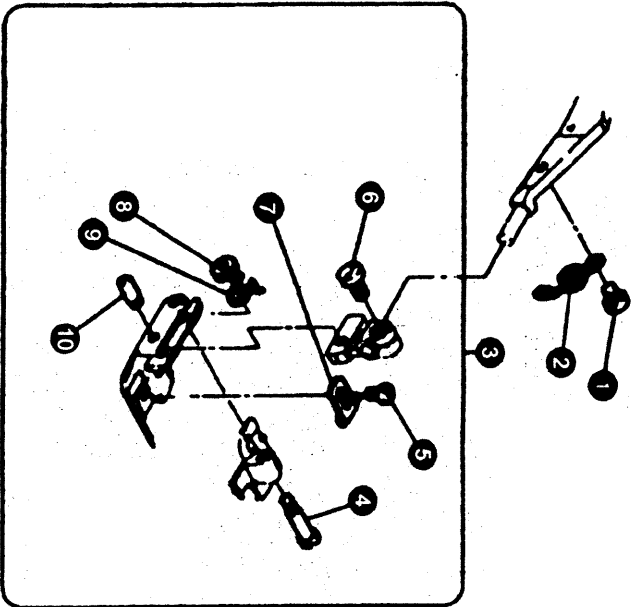

● 495H

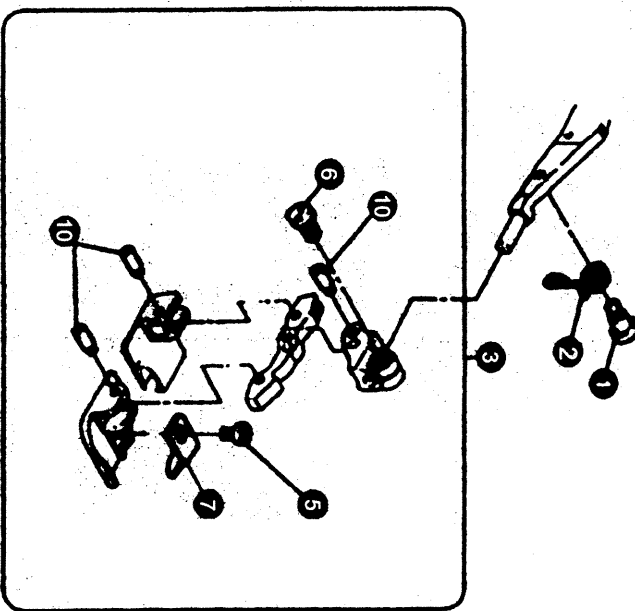

● 493, 494

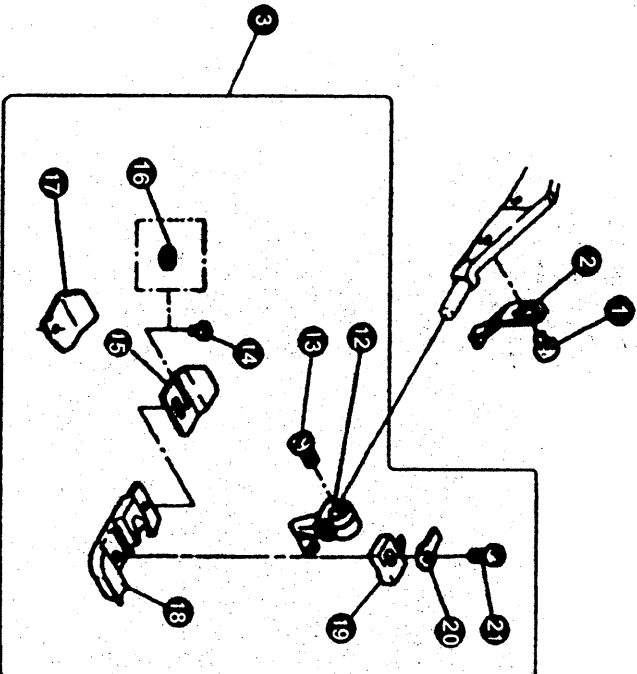

十三. 抬压脚部件(2)/PRESSER FOOT LIFT PARTS(2)

序号 No	图号/Ret. No.	名称/Description	件数/Qt				
			3	4	5	5H	
1	S120202004	压脚弹簧螺钉(M3×4)			1		
2	155800021	压脚弹簧			1		
3	039720000	压脚组件			1		
	39T7-003B2	主压脚底板			1		
	39T7-003B3	副压脚底板			1		
	39T7-003B1	压脚托架			1		
4	39T7-001A3	压脚底板螺钉			1		
5	39T7-001A6	缝料调节板螺钉			1		
6	28T1-007	压脚托架螺钉			1		
7	39T7-001A5	缝料调节板			1		
8	39T7-001A4	压脚底板螺母			1		
9	39T7-001A10	压脚底板螺钉簧			1		
10	77T7-001A4	压脚托架销钉			1		
1	155A20006	压脚弹簧螺钉			1		
2	155B00025	压脚弹簧			1		
3	77T7-001A	压脚组件			1		
	77T7-001A1	主压脚底板			1		
	77T7-001A2	副压脚底板			1		
	77T7-001A3	压脚托架			1		
	77T7-001A5	压脚底板连接杆			1		
5	6A2-14	缝料调节板螺钉			1		
6	28T1-007	压脚托架螺钉			1		
7	77T7-001A6	缝料调节板			1		
10	77T7-001A4	压脚托架销			1	3	
1	S120202004	限位片螺钉(M3×4)			1		
2	159700002	压脚限位片			1		
3	159710000	压脚组件			1		
12	159710007	压脚托架			1		
13	028100007	压脚托架螺钉			1		
14	39T7-001A6	压脚罩板螺钉			1		
15	28T6-019A1	压脚罩板			1		
16	GB97-76	压脚罩板垫圈 2.5			1		
17	159710002	压脚罩板			1		
18	159710001	主压脚底板			1		
19	159710006	编结导块			1		
20	159710005	压脚定位片			1		
21	28T1-041	编结导块螺钉			1		
3	160710000 160730000	压脚组件 压脚组件(三排齿)	Presser foot complete Presser foot complete		1 1		

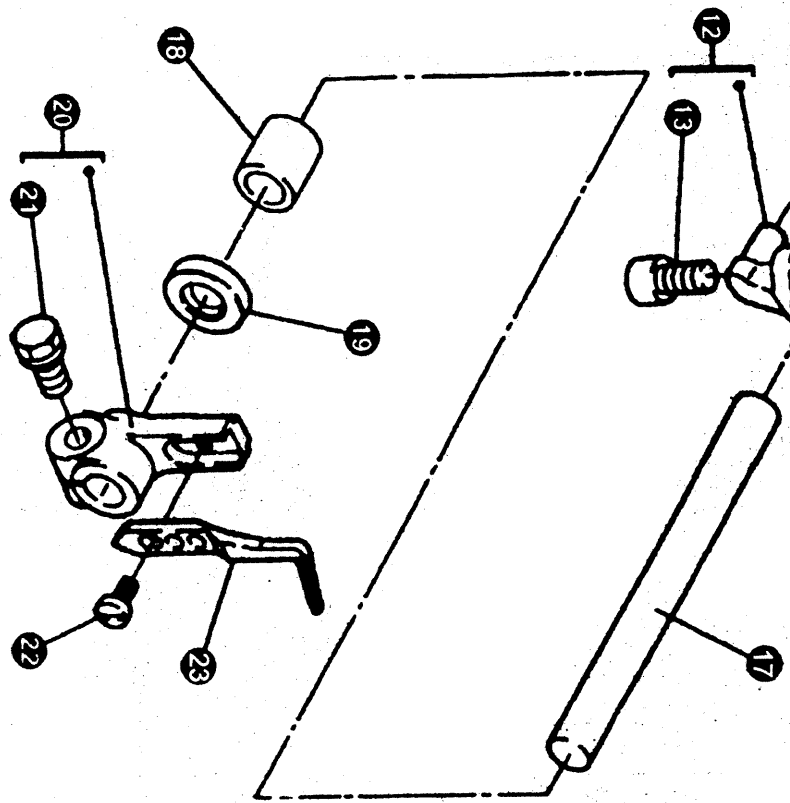
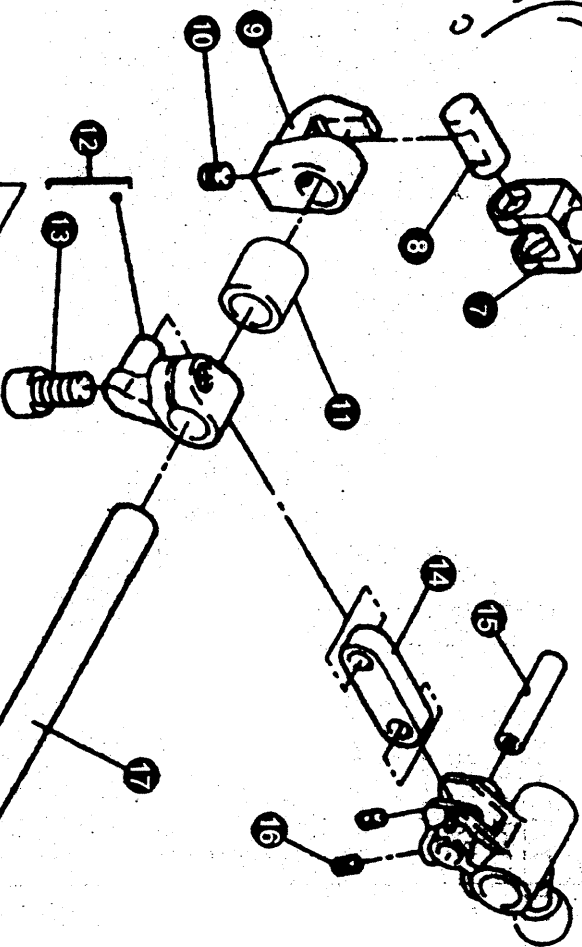
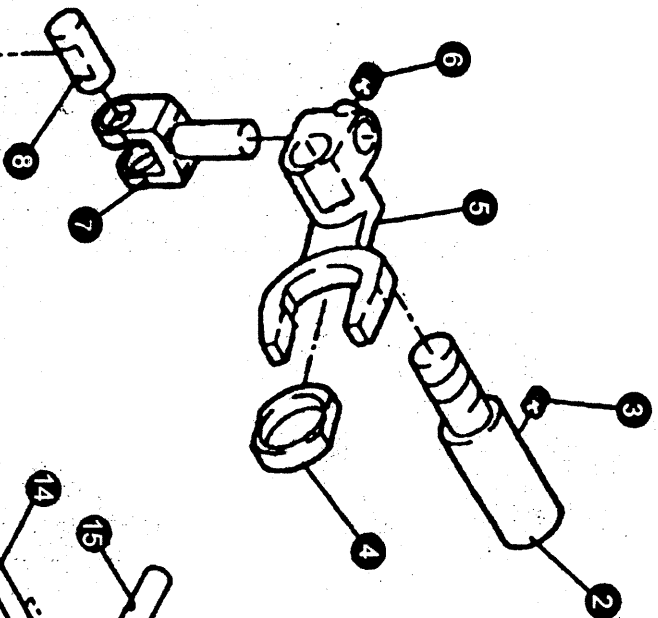
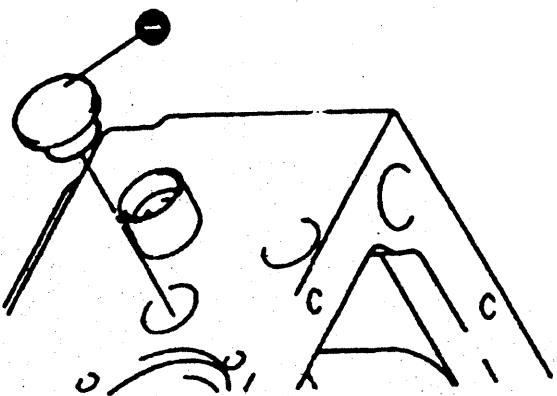

十四. 前弯针部件(1)/FRONT LOOPER PARTS(1)

序号 No	图号/Rat. No.	名称/Description	件数/Qt				
			3	4	5	5H	
1	155500017	销轴孔橡皮塞			1	1	
2	155700003	前弯针拨叉销轴			1	1	
3	B12500532	前弯针拨叉销轴支紧螺钉(M5×5)			1	1	
4	155700002	前弯针拨叉滑套			1	1	
5	155700001	前弯针拨叉			1	1	
6	B12500532	接头支紧螺钉(M5×5)			1	1	
7	155700004	前弯针轴向运动接头			1	1	
8	155700005	前弯针轴向运动销			1	1	
9	155700006	前弯针轴向运动支架			1	1	
10	B12500532	支架支紧螺钉(M5×5)			1	1	
11	155700008	前弯针轴轴套			1	1	
12	155700010	前弯针曲柄			1	1	
13	155300017	前弯针曲柄夹紧螺钉			1	1	
14	039400009	前弯针连杆			1	1	
15	039400010	前弯针连杆销			1	1	
16	S150217002	连杆销支紧螺钉(M3×6)			2	2	
17	155700007	前弯针轴			1	1	
18	155700008	前弯针轴轴套			1	1	
19	028330001	前弯针轴油封			1	1	
20	155710000	前弯针架组件			1	1	
21	155730000	前弯针架组件			1	1	
22	155400010	前弯针架夹紧螺钉			1	1	
23	006300018	前弯针螺钉			1	1	
	155710002	前弯针					
	155730001	前弯针					

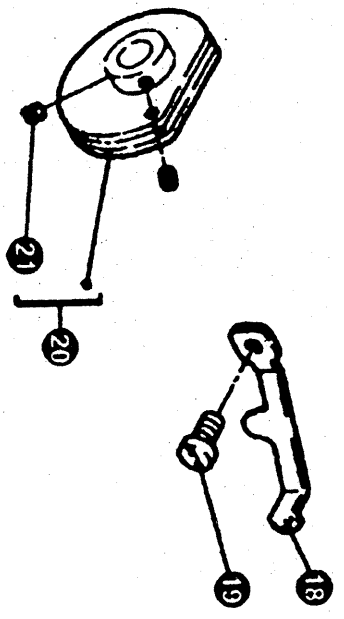
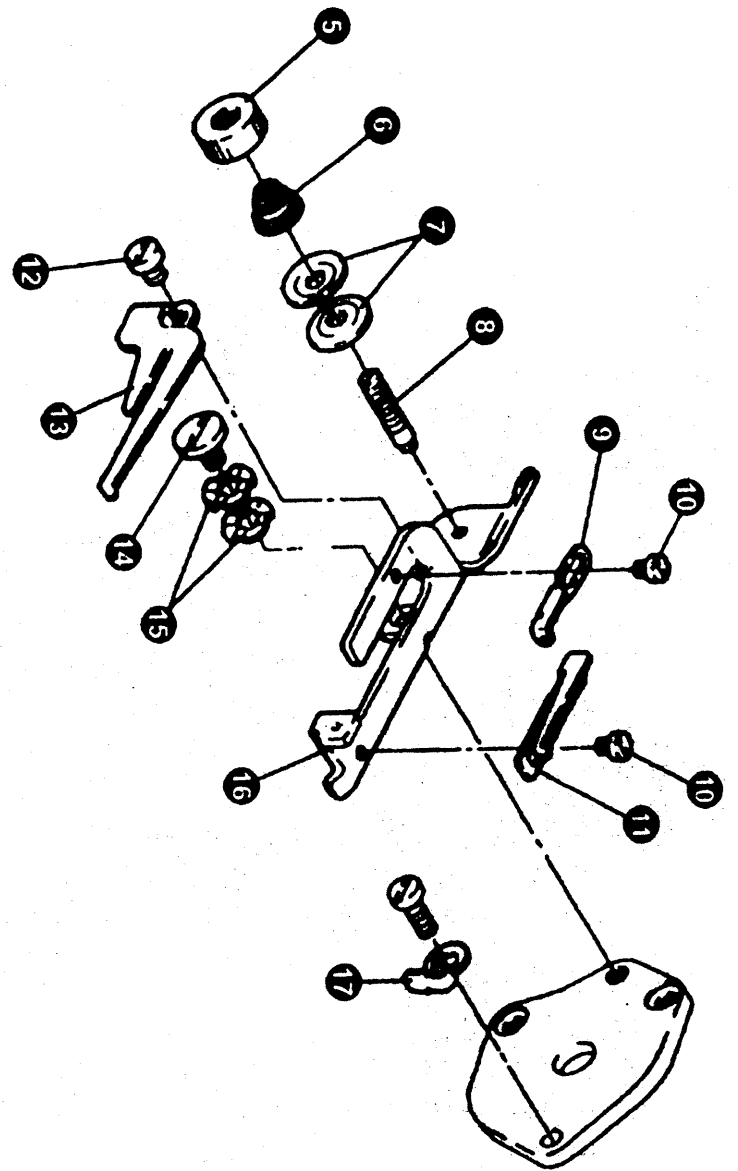
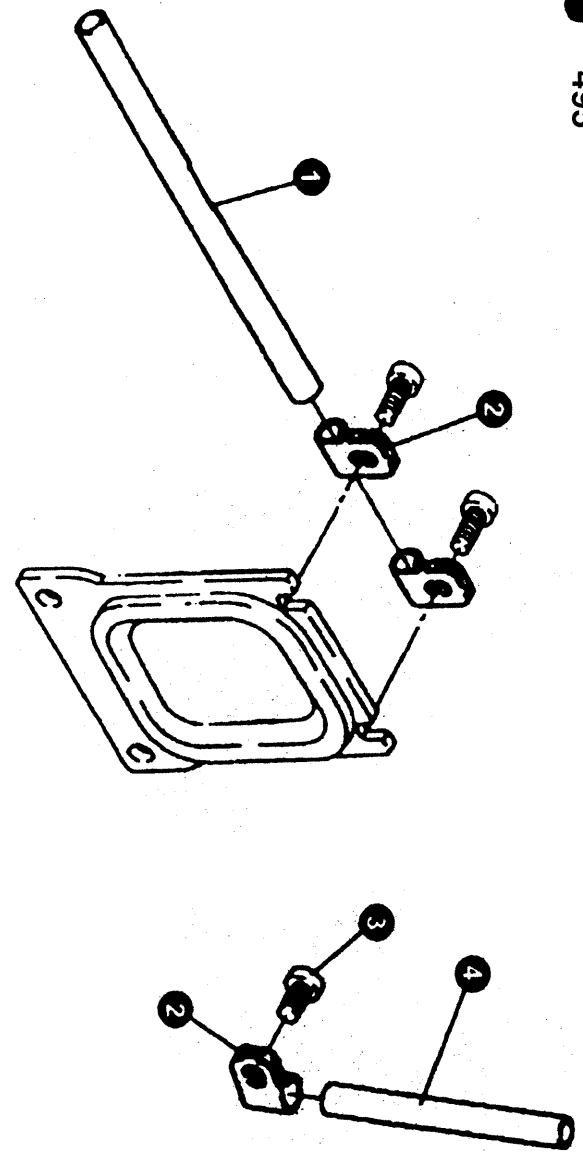

十五. 前弯针部件(2)/FRONT LOOPER PARTS(2)

序号 No	图号/Ret. No.	名称/Description	件数/Qt				
			3	4	5	5H	
1	039400037	前弯针长导线管			1	1	
2	116250002	前弯针导线管夹			3	3	
3	S150215001	导线管夹螺钉(M4×8)			1	1	
4	155A00011	前弯针短导线管			1	1	
5	155A41000	小夹线螺母组件			1	1	
6	039400042	小夹线弹簧			1	1	
7	039400041	小夹线板			2	2	
8	155A40004	夹线螺钉			1	1	
9	155A40003	左导线板线勾			1	1	
10	S150217009	右导线板螺钉(M3×4)			2	2	
11	155A40002	导线板螺钉(M4×4)			1	1	
12	S150215007	导线板			1	1	
13	155A00009	导线架轴位螺钉			1	1	
14	155100024	波形圈			1	1	
15	155100025	前弯针导线架			2	2	
16	155A40001	导线架卡簧			1	1	
17	155A00010	前弯针导线板			1	1	
18	155A00008	前弯针导线板螺钉(M4×8)			1	1	
19	S150215001	挑线凸轮组件			1	1	
20	039410N	套筒螺钉			1	1	
21	28T1-010				2	2	

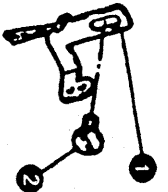

● 495

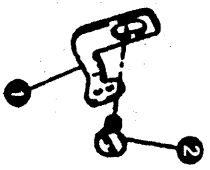
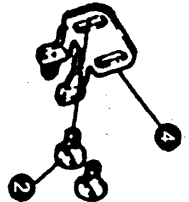

● 493, 494

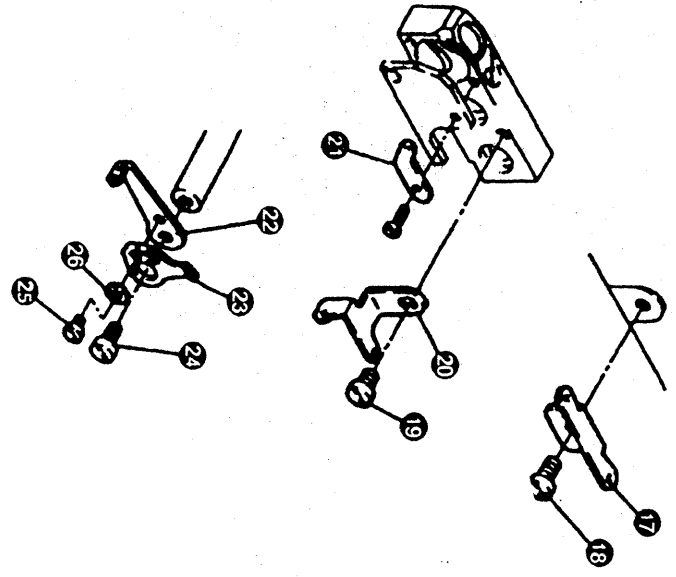
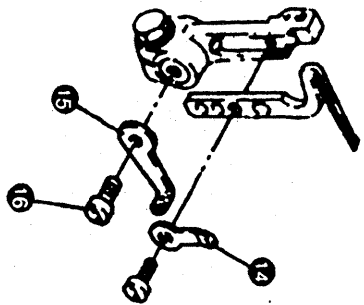
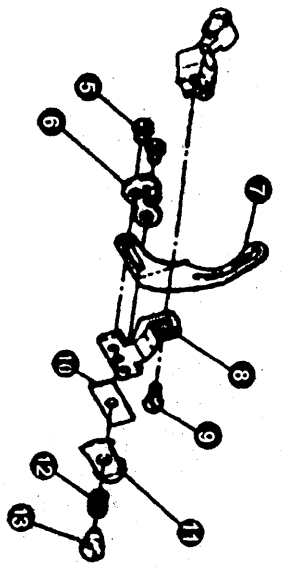
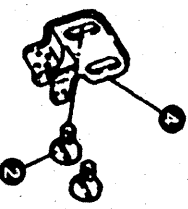

十六. 过线部件(1)/THREAD EYELETS(1)

序号 No	图号/Ret. No.	名称/Description	件数/Qt				
			3	4	5	5H	
1	159900002	机针导线架	1	1	1	1	
	155A00002	机针导线架					
2	155100034	线架螺钉	3	3	3	3	
	159900001	挑线杆过线架	1	1			
4	155A00001	挑线杆过线架					
	155A20000	挑线杆组件			1	1	
	159910000	挑线杆组件			1	1	
5	S150217008	挑线杆紧固螺钉	1	1	2	2	
6	155A20007	小过线	2	2	2	2	
7	155A20002	挑线杆			1	1	
8	155A20001	挑线杆座	1	1	1	1	
9	S120203019	挑线杆座螺钉(M3×6)	1	1	1	1	
10	155A20004	挑线板支架	1	1	1	1	
11	155A20003	挑线板	1	1	1	1	
	159910001	挑线板					
12	155A20005	挑线板弹簧	1	1	1	1	
13	155A20006	挑线板螺钉	1	1	1	1	
14	155450003	下弯针线勾	1	1	1	1	
15	155A00003	下弯针轴过线板	1	1	1	1	
16	S150215008	螺钉(M4×6)	1	1	1	1	
17	155A00004	上下弯针上过线板	1	1	1	1	
18	S150215001	过线板螺钉(M4×8)	1	1	1	1	
19	S150215008	上弯针过线板螺钉(M4×6)	2	2	2	2	
20	155A00005	上弯针过线板	1	1	1	1	
21	155400018	导架座小过线	1	1	1	1	
22	155A00006	上弯针轴小过线	1	1	1	1	
23	155A00007	上弯针轴小过线	1	1	1	1	
24	S150215001	大拨线紧固螺钉(M4×8)	1	1	1	1	
25	S120202004	小拨线调节螺钉(M3×4)	1	1	1	1	
26	S8A3103003	小拨线调节螺钉垫圈 3	1	1	1	1	

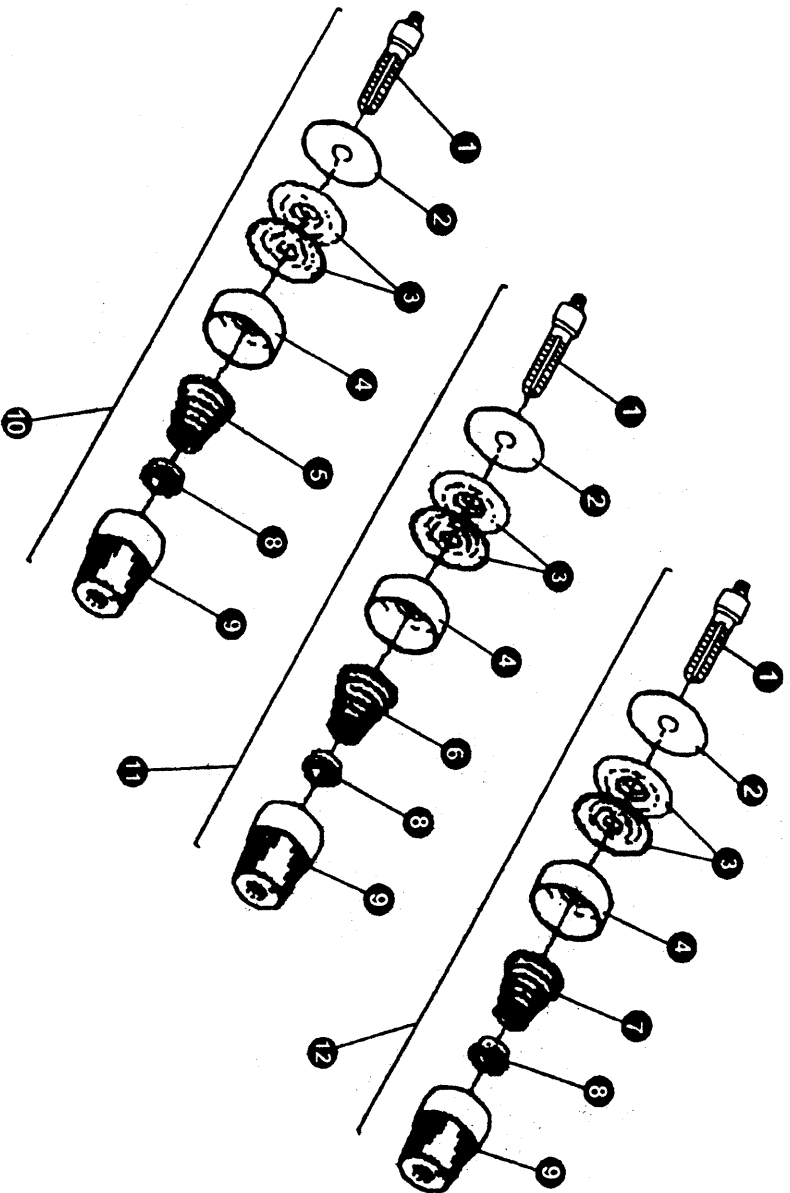

493

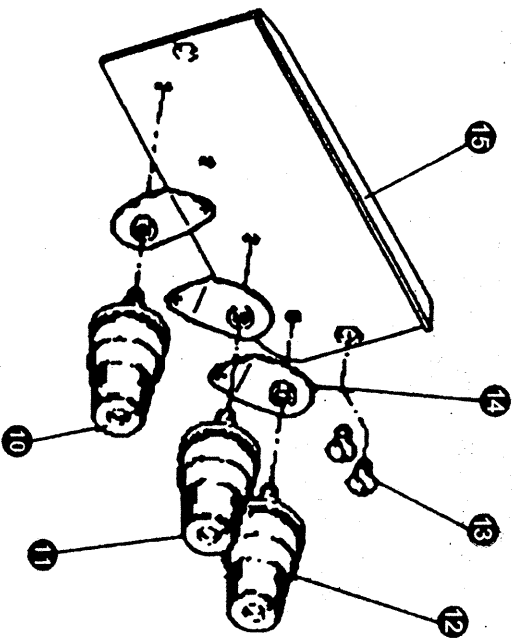

494, 495

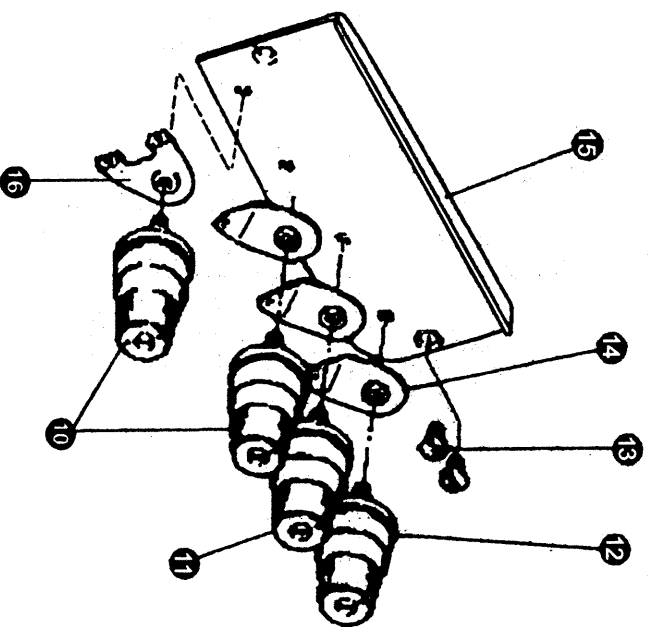

十七. 过线部件(2)/THREAD EYELETS(2)

序号 No	图号/Ret. No.	名称/Description	件数/Ot				
			3	4	5	5H	
1	028280001	压线总螺钉	3	4	4	4	4
2	028283007	压线板毡垫	3	4	4	4	4
3	022160005	压线板	6	8	8	8	8
4	028280002	压线圈	3	4	4	4	4
5	028283003	压线簧(直针)	1	2	2	2	2
6	028283001	压线簧(上弯针)	1	1	1	1	1
7	028283002	压线簧(下弯针)	1	1	1	1	1
8	028283004	调节定位圈	3	4	4	4	4
9	028283005	调节螺母	3	4	4	4	4
10	028280000	压线器组件(直针)	1	2	2	2	2
11	028280000	压线器组件(上弯针)	1	1	1	1	1
12	028280000	压线器组件(下弯针)	1	1	1	1	1
13	116400008	主过线板紧固螺钉	2	2	2	2	2
14	028283008	压线螺母过线板	3	3	3	3	3
15	155A10000	主过线板组件	1	1	1	1	1
16	155A10000	直针过线板	1	1	1	1	1

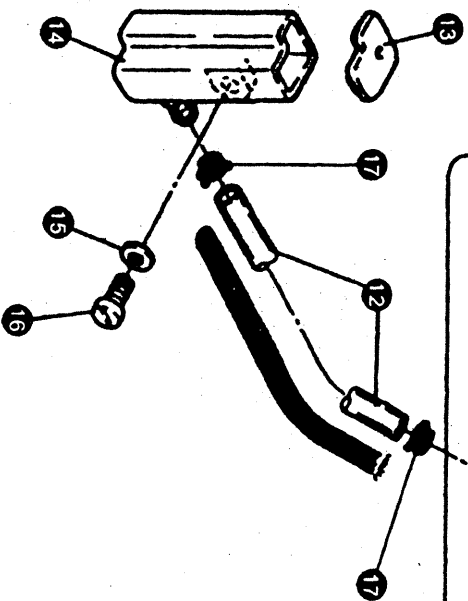
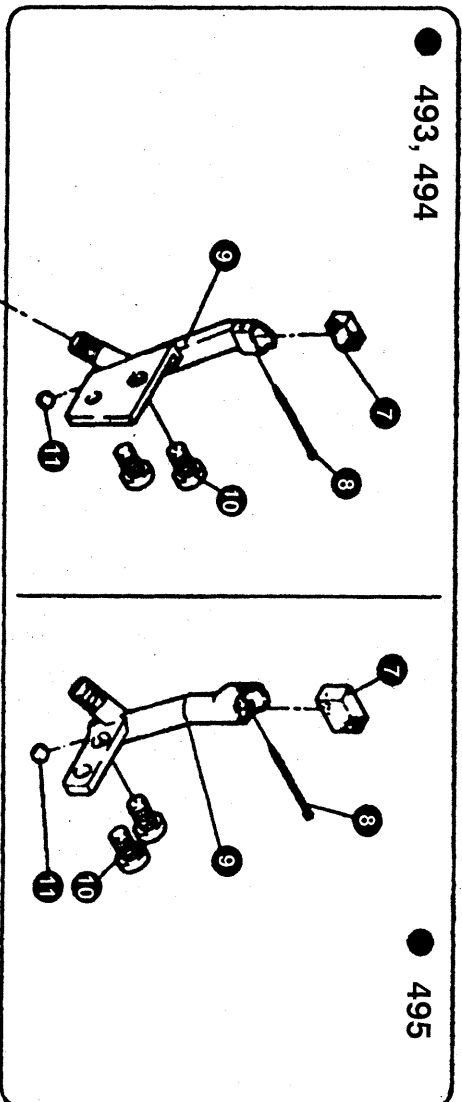
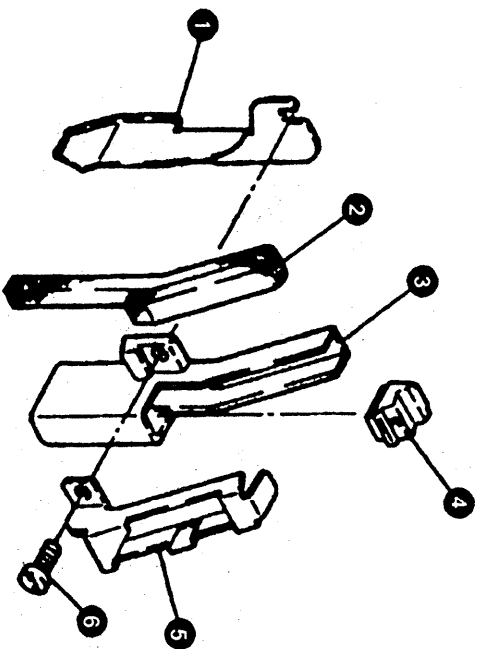

● 493, 494

● 495

十八. 润滑部件(1)/LUBRICATING PARTS(1)

序号 No	图号/Ret. No.	名称/Description	件数/Ot				
			3	4	5	5H	
1	155900019	导油板	1	1	1	1	
2	155920003	上硅油盒油毡	1	1	1	1	
3	155920001	上硅油盒	1	1	1	1	
4	155920002	上硅油盒盖	1	1	1	1	
5	155900018	上硅油盒导线盖	1	1	1	1	
6	S150215009	上硅油盒紧固螺钉(M4×10)	1	1	1	1	
7	155930002	机针冷却器上油毡			1	1	
	155930003	机针冷却器下油毡			1	1	
	159810002	机针冷却器油毡	1	1		1	
8	统一大头针	油毡销钉	1	1	1	1	
9	159810001	机针冷却器	1	1		1	
	155930001	机针冷却器			1	1	
10	S150215001	机针冷却器螺钉(M4×8)	2	2	2	2	
11	S8A3105006	机针冷却器钢球 4	1	1	1	1	
12	155900020	机针冷却器油管	1	1	1	1	
13	155900023	下硅油盒盖	1	1	1	1	
14	155900022	下硅油盒	1	1	1	1	
15	S8A3103003	下硅油盒螺钉垫圈 4	1	1	1	1	
16	S150215009	下硅油盒螺钉(M4×10)	1	1	1	1	
17	028700011	机针冷却器油管夹	2	2	2	2	

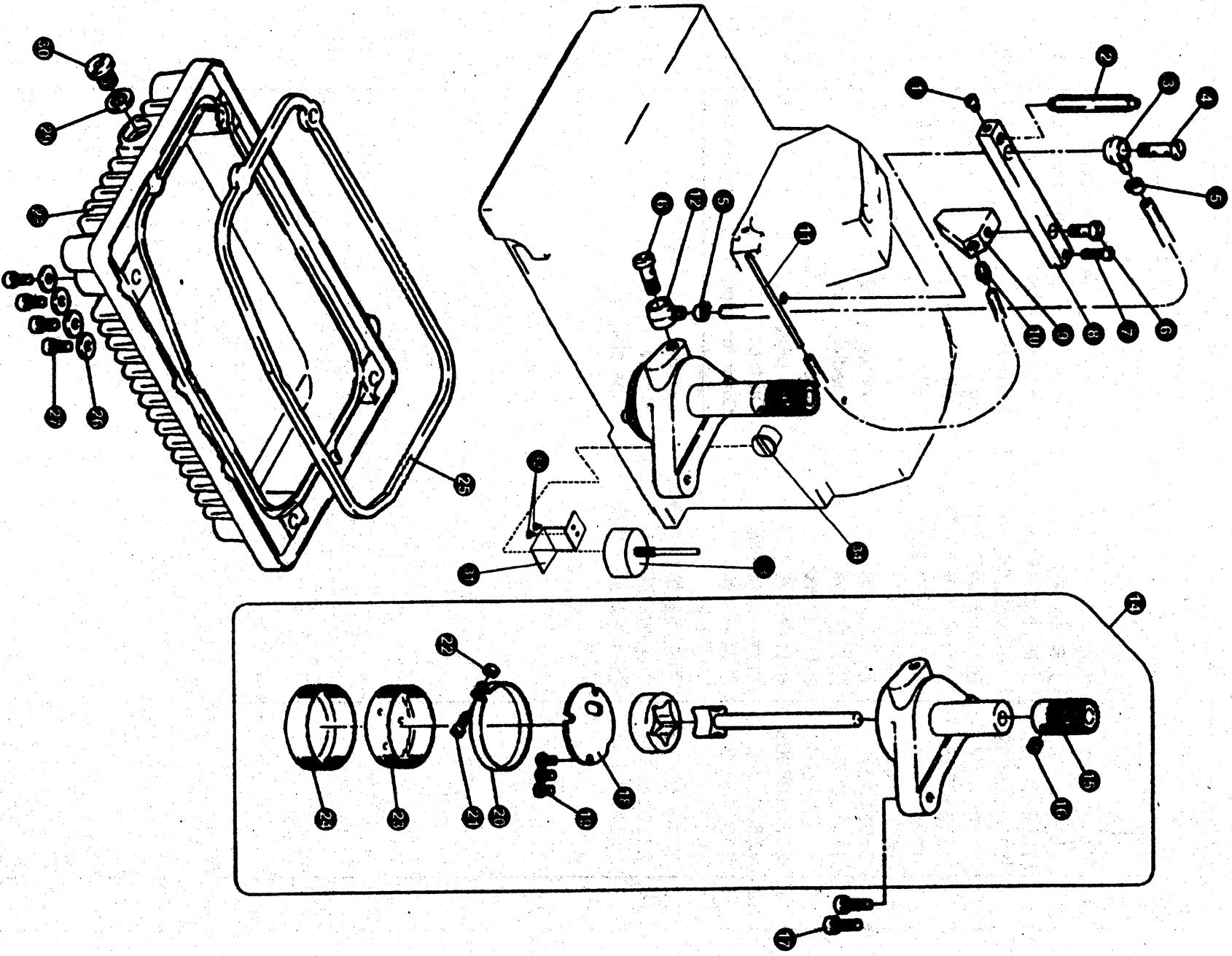

十九. 润滑部件(2) / LUBRICATING PARTS(2)

序号 No	图号/Ret. No.	名称/Description	件数/Ot				
			3	4	5	5H	
1	S150215007	配油器封油螺钉(M4×4)	1	1	1	1	
2	155900007	油窗喷油嘴	1	1	1	1	
3	028700010	溅油接头	2	2	2	2	
4	155900004	溅油长螺钉	1	1	1	1	
5	028700011	溅油接头夹	2	2	2	2	
6	155900005	溅油短螺钉	2	2	2	2	
7	S150215005	配油器紧固螺钉(M4×16)	1	1	1	1	
8	155900006	配油器	1	1	1	1	
9	155900011	回油器	1	1	1	1	
10	155900010	回油管接头	1	1	1	1	
11	155900008	针杆吸油铜管	1	1	1	1	
14	155910000	油泵组件	1	1	1	1	
15	155910001	蜗轮	1	1	1	1	
16	B12500532	蜗轮螺钉(5×5)	1	1	1	1	
17	S150220003	油泵体支紧螺钉(M4×16)	2	2	2	2	
18	122T8-004C4	油泵体盖	1	1	1	1	
19	S150217010	油泵体螺钉(M3.5×6)	3	3	3	3	
20	155910006	过滤网压环	1	1	1	1	
21	S150217012	压环螺钉(M3×8)	1	1	1	1	
22	S150559001	压环螺钉螺母	1	1	1	1	
23	155910004	过滤网(粗)	1	1	1	1	
24	155910005	过滤网(细)	1	1	1	1	
25	155900013	油盘密封圈	1	1	1	1	
26	155900017	油盘紧定螺钉垫圈	4	4	4	4	
27	S150220015	油盘紧定螺钉(M5×12)	4	4	4	4	
28	155900012	油盘	1	1	1	1	
29	28T7-025H	油盘放油螺钉密封圈	1	1	1	1	
30	028700026	油盘放油螺钉	1	1	1	1	
31	155900025	油量显示器支架	1	1	1	1	
32	S150215008	支架螺钉(M4×6)	2	2	2	2	
33	155900026	油量显示器	1	1	1	1	
34	155900027	油位显示器窗	1	1	1	1	

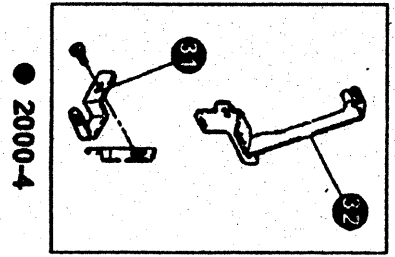
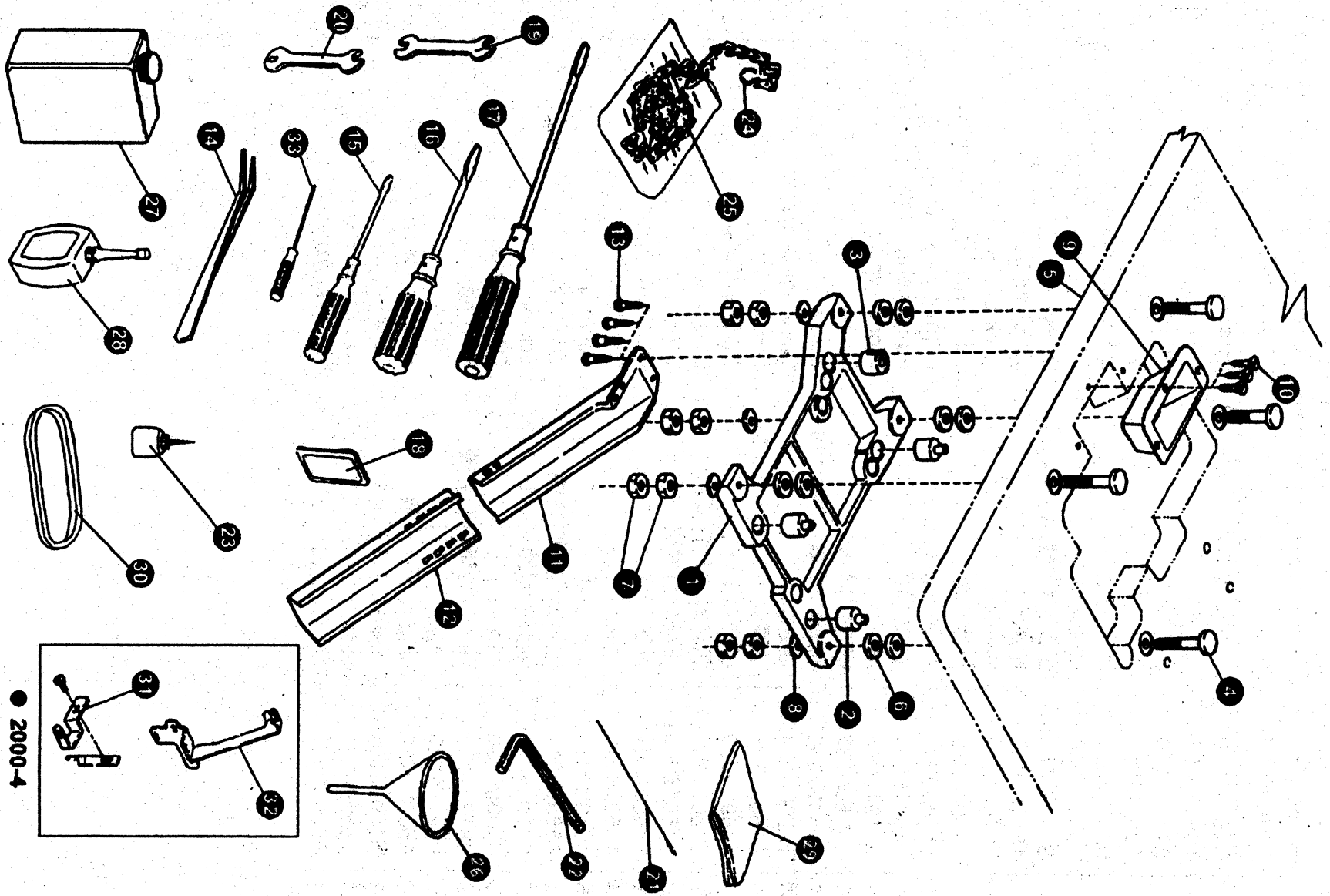

● 2000-4

二十. 附件/ACCESSORIES

序号 No	图号/Ret. No.	名称/Description	件数/Ot				
			3	4	5	5H	
1	28T8-001	机头托盘	1	1	1	1	
2	28T8-004A	机头防震销垫	3	3	3	3	
3	28T8-005	机头防震垫	1	1	1	1	
4	28T8-002	台板连接螺钉	4	4	4	4	
5	155F00001	台板	1	1	1	1	
6	110F10008	台板托盘连接垫	8	8	8	8	
7	GB52009	台板连接螺母	8	8	8	8	
8	BO10038	台板连接螺钉圈	4	4	4	4	
9	28T8-006	废料斗	1	1	1	1	
10	GB100-76	废料斗木螺钉	3	3	3	3	
11	28T8-007	废料槽(上)	1	1	1	1	
12	28T8-008	废料槽(下)	1	1	1	1	
13	GB99-76	废料槽木螺钉	4	4	4	4	
14		穿线钳	1	1	1	1	
15		螺钉开刀(小)	1	1	1	1	
16		螺钉开刀(中)	1	1	1	1	
17		螺钉开刀(大)	1	1	1	1	
18	DC x 27	机针	1包	1包	1包	1包	
19		双头扳手	1	1	1	1	
20	39T10-005	专用扳手	1	1	1	1	
21	39T10-001	穿线钢丝	1	1	1	1	
22		A型内六角扳手 5	1	1	1	1	
		内六角扳手 3	1	1	1	1	
		内六角扳手 2.5	1	1	1	1	
		内六角扳手 2	1	1	1	1	
23		硅油壶	1	1	1	1	
24		瓜子链挂勾	2	2	2	2	
25		瓜子链	50节	50节	50节	50节	
26		油斗	1	1	1	1	
27	155F00002	小油壶	1	1	1	1	
28	22T9-001	油箱	1	1	1	1	
29		塑料机头罩	1	1	1	1	
30	GB1171-74	三角皮带 0-900	1	1	1	1	
31	159F00001	导带架(上)	1	1	1	1	
32	159F00002	导带架(下)	1	1	1	1	
33	110F00005	内六角起子	1	1	1	1	

Parts Manual for 493/494/495

CONSEW Since 1898
®

CONSOLIDATED SEWING MACHINE CORP.
INDUSTRIAL SEWING & CUTTING EQUIPMENT

Main Office

131 West 25th Street
New York, NY 10001
Tel: 212-741-7788
Fax: 212-741-7787

Miami Branch Office

7855 N.W. 29th St. (#166)
Miami, FL 33122
Tel: 305-471-0200
Fax: 305-471-0243

West Coast Branch Office

1400 South Broadway
Los Angeles, CA 90015
Tel: 213-745-8844
Fax: 213-745-8855

e-mail: consew@worldnet.att.net

web: www.consew.com

